



www.Discount-Equipment.com



EN

OPERATING INSTRUCTIONS

TRACKED MINIDUMPER CARRY 107 • 107-E

serial numbers from nr.:

CARRY 107 MC*00430

CARRY 107-E MC*00430

(Original instructions)

To order go to Discount-Equipment.com

03/17 – R00

Code 2050207044



TO PURCHASE THIS PRODUCT PLEASE CONTACT US



**Equipment Financing and
Extended Warranties Available**



**Discount-Equipment.com is your online resource for
commercial and industrial quality parts and equipment sales.**

561-964-4949

visit us on line @ www.discount-equipment.com

Select an option below to find your Equipment

Search by Manufacturer

Search by Product Type

Request a Quote

We sell worldwide for the brands: Genie, Terex, JLG, MultiQuip, Mikasa, Essick, Whiteman, Mayco, Toro Stone, Diamond Products, Generac Magnum, Airman, Haulotte, Barreto, Power Blanket, Nifty Lift, Atlas Copco, Chicago Pneumatic, Allmand, Miller Curber, Skyjack, Lull, Skytrak, Tsurumi, Husquvarna Target, Stow, Wacker, Sakai, Mi-T-M, Sullair, Basic, Dynapac, MBW, Weber, Bartell, Bennar Newman, Haulotte, Ditch Runner, Menegotti, Morrison, Contec, Buddy, Crown, Edco, Wyco, Bomag, Laymor, EZ Trench, Bil-Jax, F.S. Curtis, Gehl Pavers, Heli, Honda, ICS/PowerGrit, IHI, Partner, Imer, Clipper, MMD, Koshin, Rice, CH&E, General Equipment, Amida, Coleman, NAC, Gradall, Square Shooter, Kent, Stanley, Tamco, Toku, Hatz, Kohler, Robin, Wisconsin, Northrock, Oztec, Toker TK, Rol-Air, APT, Wylie, Ingersoll Rand / Doosan, Innovatech, Con X, Ammann, Mecalac, Makinex, Smith Surface Prep, Small Line, Wanco, Yanmar

CONTENTS

ROUTINE MAINTENANCE

PREFACE

SAFETY INFORMATION

| | | |
|----------|---|-----------|
| 1 | SAFETY MEASURES | 1 |
| 1.1 | GENERAL | 1 |
| 1.2 | USE OF THE MACHINE | 2 |
| 1.3 | DRIVING SAFETY | 3 |
| 1.4 | LOADING AND TRANSPORT | 3 |
| 1.5 | PARKING | 4 |
| 1.6 | SERVICE | 4 |
| 1.7 | SAFETY LABELS AND SIGNS | 6 |
| 2 | INSTRUCTIONS FOR USE | 7 |
| 2.1 | MACHINE CONTROLS | 7 |
| 2.1.1 | MACHINE TRAVEL (Levers A and B) | 8 |
| 2.1.2 | DOUBLE SPEED (Lever C) | 9 |
| 2.1.3 | TOOL HOLDER CONTROLS (Lever D) | 9 |
| 2.1.4 | THROTTLE CONTROL LEVER (Lever E) | 9 |
| 2.1.5 | LOADING SHOVEL LEVER (OPTIONAL) (Lever F) | 9 |
| 2.1.6 | EXTENSION - RETRACTING LEVER (Lever G) | 9 |
| 2.1.7 | USING THE POWER PORTS FOR MOBILE TOOLS (OPTIONAL) (Lever F) | 9 |
| 2.1.8 | BATTERY CUT-OFF (<i>Switch H</i>) | 9 |
| 2.2 | USE OF THE ENGINE | 10 |
| 2.2.1 | GASOLINE ENGINE STARTING | 10 |
| 2.2.2 | SWITCH OFF THE GASOLINE ENGINE | 10 |
| 2.2.3 | STARTING OF DIESEL ENGINE | 11 |
| 2.2.4 | SWITCH OFF DIESEL ENGINE | 11 |
| 2.2.5 | DIESEL ENGINE ELECTRIC SCHEDULE | 11 |
| 2.2.6 | FUEL SEDIMENTER | 11 |
| 2.3 | WARMING THE MACHINE | 11 |
| 2.4 | LIFTING THE MACHINE | 12 |
| 2.5 | LOADING AND UNLOADING THE MACHINE | 12 |
| 2.6 | ATTACHMENTS | 13 |
| 2.7 | ACCESSORIES AND THEIR USE | 14 |
| 2.7.1 | BUCKET | 14 |
| 2.7.2 | SELF-LOADING SHOVEL | 14 |
| 2.7.3 | PLATFORM | 14 |
| 2.7.4 | CONCRETE MIXER KIT | 15 |
| 2.7.5 | FOOTBOARD | 15 |
| 2.7.6 | USE OF THE AUXILIARY POWER PORTS | 15 |
| 2.7.7 | USE OF THE AUXILIARY POWER PORTS HI FLOW (OPTIONAL) | 15 |
| 2.7.8 | GRADER BLADE USER INSTRUCTIONS (OPTIONAL ACCESSORY) | 16 |
| 2.7.9 | USING THE GRADER BLADE AS A SNOW PLOUGH (OPTIONAL ACCESSORY) | 16 |
| 2.7.10 | INSTRUCTIONS FOR SELF-LOADING SHOVEL ASSEMBLY. (OPTIONAL) | 17 |
| 2.7.11 | ASSEMBLY INSTRUCTIONS FOR CONCRETE MIXING KIT SELF-LOADING SHOVEL. (OPT.) | 18 |
| 2.7.12 | INSTALLING THE HI FLOW AUXILIARY PTO. (OPTIONAL) | 19 |
| 2.7.13 | PARKING BRAKE | 19 |
| 2.8 | REPLACEMENT PROCEDURE OF ACCESSORIES | 20 |
| 2.8.1 | PROCEDURE OF RELEASE-LINK-UP OF ACCESSORIES | 20 |
| 2.8.2 | ACCESSORY FITTING AND CLAMPING PROCEDURE | 20 |
| 2.8.3 | INSTRUCTIONS FOR BUCKET LIFTING WITH SHOVEL OR CONCRETE MIXER KIT | 21 |
| 2.8.4 | INSTRUCTIONS FOR ACCESSORY RELEASE BY USING LIFTING JACK | 22 |
| 2.8.5 | INSTRUCTIONS FOR ACCESSORY LINK-UP BY USING LIFTING JACK | 23 |
| 2.8.6 | INSTRUCTIONS FOR CONCRETE MIXER KIT RELEASE BY USING LIFTING JACK | 24 |
| 2.8.7 | INSTRUCTIONS FOR CONCRETE MIXER KIT LINK-UP BY USING LIFTING JACK | 25 |
| 2.8.8 | INSTRUCTIONS FOR GRADER BLADE KIT RELEASE | 26 |
| 2.8.9 | INSTRUCTIONS FOR GRADER BLADE KIT LINK-UP | 26 |
| 2.9 | PRECAUTIONS FOR USING RUBBER TRACK SHOES | 27 |
| 2.10 | PARKING THE MACHINE | 27 |

| | | |
|----------|--|-----------|
| 3 | MAINTENANCE | 28 |
| 3.1 | MAINTENANCE INTERVALS | 28 |
| 3.2 | RECOMMENDED LUBRICANT TABLE | 28 |
| 3.3 | WHEN REQUIRED MAINTENANCE AND CHECKS..... | 29 |
| 3.3.1 | CHECKING THE TRACK TENSION..... | 29 |
| 3.3.2 | TRACK TENSION ADJUSTMENT..... | 29 |
| 3.3.3 | RUBBER TRACK SHOE MAINTENANCE..... | 29 |
| 3.3.4 | BATTERY MAINTENANCE | 30 |
| 3.3.5 | LUBRIFICATION IN GENERAL..... | 30 |
| 3.4 | DAILY CHECKS AND MAINTENANCE..... | 31 |
| 3.4.1 | ENGINE OIL LEVEL | 31 |
| 3.4.2 | HYDRAULIC OIL TANK LEVEL | 31 |
| 3.4.3 | FILLING THE FUEL TANK..... | 31 |
| 3.4.4 | WALK-AROUND INSPECTION..... | 32 |
| 3.5 | CHECKS AND MAINTENANCE EVERY 50 HOURS | 32 |
| 3.5.1 | CLEANING THE AIR FILTERING ELEMENT..... | 32 |
| 3.5.2 | FUEL TANK CLEANING AND DRAIN (DIESEL ENGINE)..... | 32 |
| 3.6 | CHECKS AND MAINTENANCE EVERY 200 HOURS | 32 |
| 3.6.1 | HYDRAULIC OIL REPLACEMENT..... | 32 |
| 3.6.2 | CLEANING THE FUEL SEDIMENTOR (GASOLINE MOTOR)..... | 32 |
| 3.6.3 | AIR FILTERING ELEMENT REPLACEMENT | 33 |
| 3.6.4 | HYDRAULIC SYSTEM STRAINER REPLACEMENT | 33 |
| 3.7 | CHECKS AND MAINTENANCE EVERY 600 HOURS (OR AFTER ONE YEAR) | 33 |
| 3.7.1 | HYDRAULIC OIL REPLACEMENT..... | 33 |
| 3.8 | UNUSUAL OPERATING CONDITIONS..... | 34 |
| 3.9 | LONG TIME STORAGE..... | 35 |
| 4 | TROUBLE SHOOTING | 36 |
| 4.1 | TROUBLE AND REMEDIES | 36 |
| 4.2 | SPARE PARTS..... | 36 |
| 5 | HYDRAULIC SYSTEM | 37 |
| 5.1 | TECHNICAL DATE | 37 |
| 5.2 | HYDRAULIC SYSTEM DIAGRAM 4 ELEMENTS | 37 |
| 5.3 | HYDRAULIC SYSTEM DIAGRAM 5 ELEMENTS | 38 |
| 5.4 | HYDRAULIC SYSTEM DIAGRAM 6 ELEMENTS | 39 |
| 6 | TECHNICAL DATA | 40 |
| 6.1 | GENERAL SPECIFICATIONS..... | 40 |
| 6.2 | MACHINE DIMENSIONS..... | 40 |
| 6.3 | CONCRETE MIXER KIT SPECIFICATIONS..... | 40 |
| 6.4 | LEVEL OF EXPOSURE TO VIBRATIONS | 41 |
| 6.5 | OVERALL DIMENSIONS | 42 |

- 1) **DICHIARAZIONE "CE" DI CONFORMITÀ (ORIGINALE)**
(Direttiva 2006/42/CE, allegato II, 1A)
- 2) Fabbricante: **KATO IMER S.p.A.**
- 3) Indirizzo: località CUSONA - 53037 SAN GIMIGNANO (SI) - ITALY
- 4) File tecnico compilato da: Direttore tecnico **KATO IMER S.p.A.**
- 5) Indirizzo: località CUSONA - 53037 SAN GIMIGNANO (SI) - ITALY
- 6) Dichiaro che la macchina categoria: **CRAWLER COMPACT DUMPER**
- 7) Tipo: **CARRY 107**
- 8) Numero di serie: **MC** _____
- 9) Potenza netta installata (kW/rpm): **6 / 3600**
- 10) È conforme ai requisiti della Direttiva Macchine **2006/42/CE**, come modificata e alla legislazione nazionale che la traspone.
- 11) È conforme alle condizioni della Direttiva 2000/14/CE modificata dalla 2005/88/CE "emissione acustica ambientale delle macchine ed attrezzature destinate a funzionare all'aperto" e alla legislazione nazionale che la traspone. (Dlgs.262/2002)
- Categoria macchina: *Dumper annesso I n°18*
 - Procedure applicate per le valutazioni di conformità: *controllo interno della produzione con valutazione della documentazione tecnica e controlli periodici, all. VI. (1ª procedura)*
 - Ente notificato : *ECO S.p.A. - via Mengolina, 33 - 48018 Faenza (RA) - Italy*
 - Livello di potenza sonora misurato: **L_{WA} 99 dB**
 - Livello di potenza sonora garantito: **L_{WA} 100 dB**
- 12) È conforme alle condizioni della seguente direttiva: 2014/30/CE
- 13) Sono state applicate le seguenti norme armonizzate: EN ISO 12100; EN ISO 3744; EN 474 -1; EN 474 -6
- 14) Luogo/Data: San Gimignano..... -
-
- 15) Nome : **Tsutomu Kikuchi**
- 16) Posizione: Presidente **KATO IMER S.p.A.**

SCHEDULED MAINTENANCE

Correct maintenance is essential to warrant long life of the machine in peak conditions. This is why KATO IMER has scheduled a series of checks and operations to be carried out c/o authorised service centres.

WARNING: The scheduled Maintenance coupons are specified by the Manufacturer. The failure to perform them may invalidate the guarantee.

SCHEDULED MAINTENANCE TABLE

| OPERATION \ HOURS | HOURS | | | | | | | | | |
|---|-------|-----|-----|-----|-----|------|------|------|------|---|
| | 20/50 | 200 | 400 | 600 | 800 | 1000 | 1200 | 1400 | 1600 | |
| Engine oil & filter replacement | ● | ● | ● | ● | ● | ● | ● | ● | ● | ● |
| Hydraulic system strainer replacement | ● | ● | ● | ● | ● | ● | ● | ● | ● | ● |
| Air cleaner replacement | ● | ● | ● | ● | ● | ● | ● | ● | ● | ● |
| Track tension checking and adjustment | | ● | ● | ● | ● | ● | ● | ● | ● | ● |
| Hydraulic system strainer and hydraulic oil replacement | | | | ● | | | ● | | | |

To order go to Discount-Equipment.com

PREFACE

This manual provides all the procedures and instructions required for operating, inspecting and servicing the minidumper. The procedures are designed to provide the best possible performance, productivity and safety. Please note the following rules:

- The manual must be kept on board the machine in the provided compartment.
- Before operating the machine, read this manual throughout.
- Experience will augment the prescriptions of this manual, and will be gained in supervised operation of the machine.

Some of the illustrations given in the manual may not be identical with your machine due to intervening technological developments. If you have any questions about your machine or this manual, please contact your reseller for the most recent updates.

SAFETY INFORMATION

This manual is a practical safe guide to the safe operation and control of the machine. Before operating the machine, read the manual in full. This is the best way to avoid accidents. Incorrect operation, control or servicing of the machine may cause injury or death.

Precautions are highlighted in the manual and on the machine itself with the symbol  and classified with the words **DANGER - WARNING - CAUTION**, depending on the degree of hazard. The classification is as follows:



A dangerous situation which may cause injury or death.



A potentially dangerous situation which may cause injury or death.



A potentially dangerous situation which may cause light or moderate injury. May also be used to indicate the potential for damage to the machine or its parts.

We have made every effort to reduce the risks associated with correct use of the machine and, nonetheless, we cannot be held responsible for predicting every kind of danger in all unintended operating conditions.

We have taken every effort to prevent accidents during the machine's operation, however we are not liable for all hazards in all working conditions.

The owner or operator must **ALWAYS** take care during work and have read and understood this manual sufficiently to have the basic knowledge required to operate the machine correctly.



- **BEFORE OPERATING, INSPECTING OR SERVICING THE MACHINE, READ THIS MANUAL AND MAKE SURE YOU HAVE UNDERSTOOD ITS CONTENTS.**
- **INCORRECT OPERATION OR SERVICING MAY CAUSE ACCIDENTS, INJURY OR DEATH.**
- **KEEP THIS MANUAL AT HAND FOR REFERENCE AT ALL TIMES.**
- **IF LOST OR DAMAGED, ASK YOUR RESELLER FOR ANOTHER COPY.**
- **CONSTRUCTION EQUIPMENT IS COVERED BY A VARIETY OF FEDERAL, NATIONAL AND LOCAL LEGISLATION. SINCE THIS LEGISLATION IS CONTINUALLY CHANGING AND DIFFERS FROM COUNTRY TO COUNTRY, WE CANNOT INCLUDE IT IN THIS MANUAL. THE OWNER OR OPERATOR ARE RESPONSIBLE FOR INFORMING THEMSELVES IN THIS REGARD.**
- **THE MACHINE'S COMPONENTS AND SPECIFICATIONS ARE SUBJECT TO CHANGE WITHOUT NOTICE.**
- **MAKE SURE THAT THE SUPPLIED OPERATING MANUAL CORRESPONDS TO THE FEATURES OF THE MACHINE, IN CASE OF DOUBT CONTACT KATO IMER ASSISTANCE SERVICE.**
- **KATO IMER RESERVES THE RIGHT TO CHANGE THE FEATURES OF THE MACHINE AND/OR THE CONTENTS OF THIS MANUAL, WITHOUT BEING REQUIRED TO UPDATE THE PREVIOUS MACHINE AND/OR**

1 SAFETY MEASURES

1.1 GENERAL

**WARNING**

BEFORE USING THE MACHINE MOVE AWAY EVERYONE NEARBY.

1. MAKE SURE YOU HAVE READ AND UNDERSTOOD THE INSTRUCTIONS AND WARNINGS

This manual, the nameplates and labels on the machine provide the information required for correct and safe operation of the machine. The user is responsible for reading and understanding the said information; failure to do so may lead to serious injury. Do not leave anything you have failed to understand to chance. Your reseller will provide any additional information you may require. If you lose or damage the manual, nameplates or labels, your reseller will replace them.

2. CHECK THE MINIDUMPER

Before starting work, check the minidumper and make sure there are no persons or obstacles in your work area. Before starting, carefully check the machine for signs of wear and defects.

3. HEALTH

Take special care of your mental and physical health and note that the operator of a complicated machine should be **PHYSICALLY FIT**. **NEVER** operate the machine under the influence of alcohol, medicines or drugs of any kind.

4. SNUG FITTING WORK CLOTHES

Your work clothing must be snug, without loose sleeves, rings or other jewelry, as they may become trapped in moving parts. Always wear the necessary clothes and accessories, including: helmet, safety gloves, visible clothing, safety boots and ear defenders.

5. BEFORE STARTING THE MACHINE

Since all equipment is hydraulically operated, it is **EXTREMELY IMPORTANT** that the hydraulic fluid be at temperature **BEFORE** you start working. While the fluid is heating up, the operator should check the machine's operation and whether it needs servicing. Remember; the basic principle of hydraulics is flow of hydraulic fluid. If you hear a loud noise, this means that the pump is insufficiently lubricated due to cavitation, often caused by the use of too heavy or dense oil. **NEVER OPERATE THE MACHINE** in such conditions; it can seriously damage the pump.

6. MOVING PARTS

DO NOT approach moving parts. Do not hold anything close to moving parts. This may cause serious accidents.

7. TAKE CARE IN THE VICINITY OF THE MACHINE'S HOT PARTS

Keep the engine away from buildings and other equipment during operation. Keep flammable materials away and not place anything on the engine while it is running.

DO NOT touch the engine or exhaust when the machine is running or before it has had time to cool down. These parts are very hot and cause serious burns.

8. GETTING ON AND OFF THE MACHINE

When getting on and off the machine, **ALWAYS** grip the handles.

NEVER grip the control levers when getting on or off the machine.

NEVER get on or off the machine while it is in motion.

Never attempt to get onto the machine with your hands full.

9. MAINTAIN GOOD VENTILATION

Do not use the machine for indoor works. Take all precautions to vent exhaust gas externally before starting the engine if working in a hole in the ground, tunnel or trench. In such a place, the air tends to stagnate. Breathing exhaust gas is very dangerous. Note that exhaust gases are fatally poisonous.

10. LIGHTING

The machine is designed to work in building jobsites and it does not have own lighting. It must be used in enough illuminated places.

1.2 USE OF THE MACHINE**1. EXECUTE EACH MANOEUVRE, WITH RESPECT OF SAFETY**

Execute all manoeuvres carefully. Operating brusquely the machine this can cause damages and reduce consistently efficiency. Take care of regulations that warrant safety on job site. Leave after a sufficient safety distance between machine and obstacle. Leading the machine on foot raise the platform assuring the hook.

2. DO NOT OVERLOAD

Never overload any cylinder enough to trigger the opening of the safety valve. This would cause an excessive rise in the oil temperature, lowering the useful life of the hydraulic components.

3. SECURE FOOTING FOR SAFE OPERATION

Check that the machine footing is level and firm to avoid skidding or overturning if you need to use the machine on the shoulder of a road or a slope.

4. MACHINE OPERATING LIMITS

The machine should be operated on a flat surface, but if you are moving material on sloping ground, be sure that the tracks are positioned in the direction of the slope and not crossways. If you need to work on soft, rough or unlevelled ground, take care to avoid overturning.

5. TIPPING

Be careful, during the reversal of accessory the center of gravity of the machine can moves, so the operation must be done on a stable and not yielding surface.

1.3 DRIVING SAFETY

1. WORKING MANEUVERS

In normal conditions (not emergency) **ALWAYS** steer as slowly as possible. Steering jerkily or while stationary reduces the service life of the machine and its tracks. Steer slowly so as not to overload the drive wheels, especially on uneven or sloping ground.

2. MOVING THE MACHINE IN SPECIAL CONDITIONS

If the ground is very uneven or rocky, drive the machine very slowly. **NEVER CAUSE IMPACTS** on the machine or its tracks.

3. TAKE CARE WHEN DRIVING ON SLOPES

When operating the machine on sloping ground, drive uphill in reverse, and operate the machine from the ground. Even slight roughness can cause the machine to bump around or tip over

DRIVE IN REVERSE, THE OPERATOR MUST BE UPHILL OF THE LOAD AT ALL TIMES.



CAUTION

MAX. CLIMBABLE GRADIENT 20° - 36%



CAUTION

MAX. CLIMBABLE GRADIENT WITH MAXIMUM LOAD 11° - 20%

NEVER STEER on sloping or unstable ground; the machine may tip over.

NEVER DRIVE ACROSS A SLOPE. When working on sloping ground, always drive uphill or downhill. Take great care on icy ground as the machine may skid.

1.4 LOADING AND TRANSPORT

1. PRECAUTIONS WHEN LOADING/UNLOADING THE MINIDUMPER

ALWAYS load and unload the dumper on flat ground.

ALWAYS use sufficiently thick, wide and long ramps.

Remove any ice, snow or friable material from the ramps and truck bed before loading the machine.

NEVER steer on ramps.

2. TRANSPORT

Secure the machine to the truck with steel ropes and other locking equipment.

1.5 PARKING



WARNING

IF PARKED ON SLOPING GROUND OR WHEN THE MACHINE IS OUT OF SERVICE, ALWAYS ENGAGE THE PARKING BRAKE.

IF THE MACHINE IS TO BE PARKED FOR A LONG TIME ON VERY SLOPING GROUND, CHOCK THE WHEELS WITH ADDITIONAL CHOCKS.

1. PARKING ON EMBANKMENTS AND SLOPES

NEVER LEAVE THE MACHINE PARKED on or near to an embankment, or on the edge of a dig or quarry. They may collapse under its weight. Move the machine away from such danger areas if it is to remain inactive for any time. If possible, park it on flat ground.

2. PARKING ON THE ROAD

If the machine must be parked on the road, warn other road users of its presence with barriers, flags, illuminated notices and signs.

3. LEAVING THE MACHINE UNSUPERVISED

Before leaving the machine unsupervised, **ALWAYS** switch off the engine. Make sure its chocks are placed and the parking brake engaged.

1.6 SERVICE

1. ROUTINE MAINTENANCE

Maintenance may be risky if not done with appropriate caution. Maintenance staff must be aware of the risks and implement suitable safety procedures. Before servicing or repairing the machine, always refer to the instruction manual. Before **ANY** service work, stop the engine and engage the parking brake to prevent unexpected movements which may cause injury, raise the accessory and fit its safety lock.

NEVER ALLOW ANYONE to work on the undercarriage with the accessory raised if it is not securely locked.

During maintenance operations, mark the control levers with labels. These labels can only be removed by aware personnel able to ensure that safety rules are fully observed.

SAFETY
LOCK

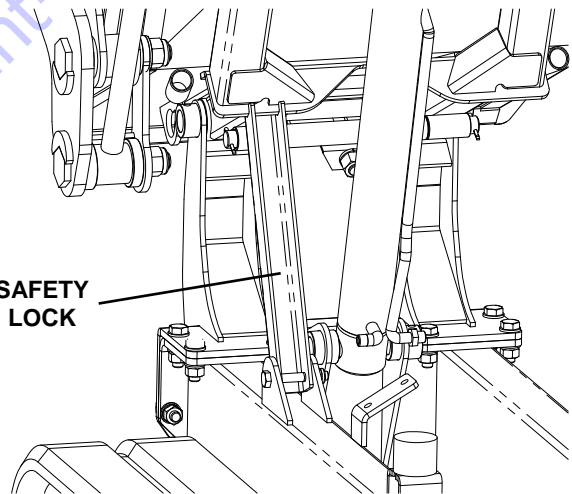

2. CLEANING THE MACHINE

Keep the machine clean. Remove all dirt and grease, and check the machine's equipment. Never leave flammable materials in the machine's work area.

3. ADJUSTING THE HYDRAULIC PRESSURE

The hydraulic pressure must be measured and adjusted by qualified staff using suitable equipment.

If such staff is not available, contact your reseller.

4. FIRE AND EXPLOSION

Always keep petrol, lubricants and coolants as far away as possible from sources of heat and ignition. Many liquids are extremely flammable. Dry immediately eventual overflows.

NEVER FILL THE FUEL TANK or lubricate the machine with the engine running.

NEVER SMOKE while filling the fuel tank or in the vicinity of flammable materials.

5. ELECTROLYTIC BATTERY MAINTENANCE

Do not touch the internal battery elements.

Battery acid burns the skin and can cause blindness if it is splashed into the eyes.

In the event of contact with the acid, rinse the skin contacted with lots of water.

Use bicarbonate of soda to neutralise the acid.

If the acid gets in your eyes, rinse thoroughly and call for medical treatment immediately.

During battery servicing, remember that charging or discharging generates a highly explosive mixture of hydrogen and oxygen.

A flame or spark can ignite these gases.

ALWAYS wear protective glasses and gloves when working with the battery.

6. HYDRAULIC SYSTEM MAINTENANCE

Before disconnecting a hydraulic line on the machine, be sure that:

- the shovel, if present, is on the ground
- the tool holder is in the lowered position
- the engine is off
- the pressurised air has been relieved from the hydraulic tank
- the control levers are moved repeatedly to lower the pressure in the pistons.

Before switching on the engine, make sure that all the connections are firmly tightened and that all the pipes and fittings are in good conditions.

If you are struck by escaping pressurised hydraulic fluid, serious reactions can occur if proper medical treatment is not administered immediately.

To order go to Discount-Equipment.com

1.7 SAFETY LABELS AND SIGNS

The machine bears a variety of safety signs and labels.

This section indicates where they are located and the respective hazards.

Make sure that all safety labels are legible. Clean and replace damaged and illegible signs.

Clean the labels with a rag, water and soap. Do not use solvents or petrol to do so.

If the label is attached to a part which must be replaced, take care to fit the new part with a new label.

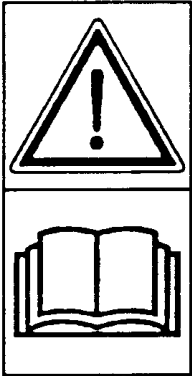
Symbol
illustratedWarning,
explanationSymbol
illustratedWarning,
explanation

- ① **Caution!**
Read the manual before operating, servicing or transporting the machine.



- ② The sign indicates the danger of burns due to contact with high temperature parts. Do not touch hot parts while the machine is operating or before having given it time to cool down after being switched off; use suitable safety equipment if necessary.

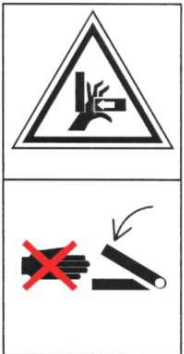

- ③ The sign indicates the shearing hazard associated with the bucket. Keep your hands away from the bucket arm while the bucket is operating.



④

- The sign indicates the hazard of being struck by objects thrown up by the tracks during movement. Read the manual before using the machine to ensure all operations are done correctly.



- ⑤ The sign indicates the hazard of crushing by unexpected movements of the accessory or bucket (if present). Keep a safe distance when the machine is operating. Always completely lower the bucket and accessory before leaving the machine unsupervised.

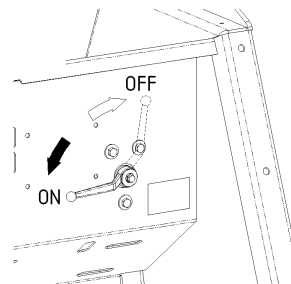

Nameplate serial number.



2 INSTRUCTIONS FOR USE

2.1 MACHINE CONTROLS

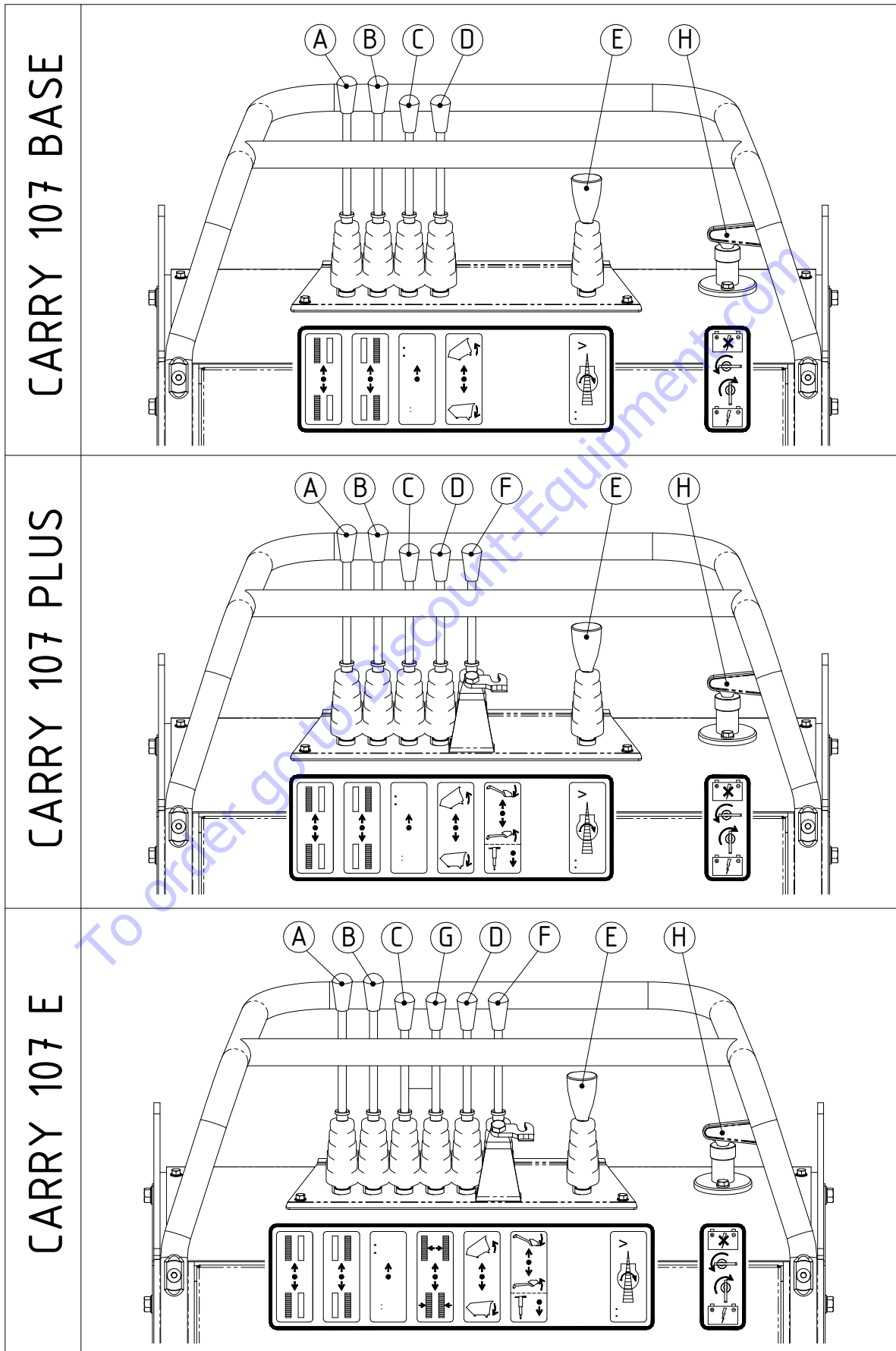

2.1.1 MACHINE TRAVEL (Levers A and B)

1. Move the lever of number's setting of engine revolutions in the desired position.
2. Check right and left travel levers as follows:

STRAIGHT TRAVEL

- Forward travel

Push both levers forwards. The machine will move towards the front (dumper end).

- STOP

Release the levers to stop the machine.

- Backward travel.

Pull both levers backwards. The machine will move towards the rear (operator end).

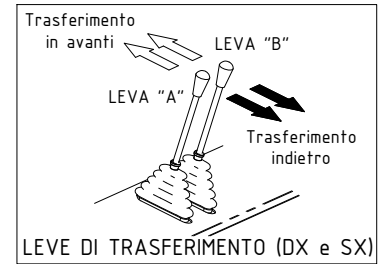

CORNERING

When cornering use the two levers as follows..

- Left turn

Push the right lever (1) forwards to travel forward and left, pull the right lever towards you to reverse and turn left.

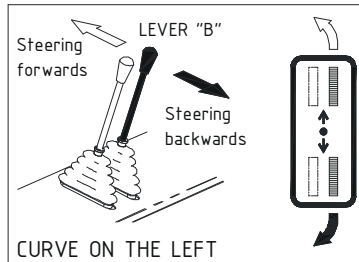

- Right turn

Push the left lever (2) forwards to travel forward and right, pull the left lever towards you to reverse and turn right.

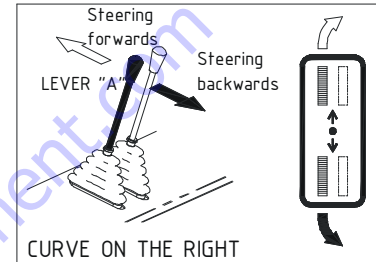

SPOT TURN

- Spot left turn

Push the right lever "B" forwards and at the same time pull the left lever "A" backwards. This operation causes a quick left turn.

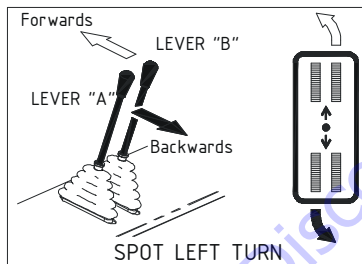

- Spot right turn

Push the left lever "B" forwards and at the same time pull the right lever "A" backwards. This operation causes a quick right turn.

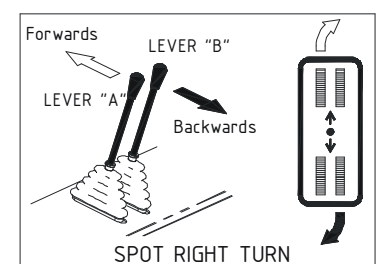

DRIVING ON SLOPING GROUND



WARNING

- LOWER THE ENGINE SPEED.
- DO NOT CHANGE DRIVING SPEED.
- IF POSSIBLE, DRIVE WITH THE TRACKS POINTING UP OR DOWN HILL, NOT ACROSS THE SLOPE.
- DO NOT STEER ON SLOPES, AS THIS CAN CAUSE THE MACHINE TO TIP OVER OR SKID SIDWAYS.
- IF THE MACHINE IS EQUIPPED WITH A BUCKET, KEEP IT AS CLOSE TO THE GROUND AS POSSIBLE WHEN DRIVING ON SLOPES.

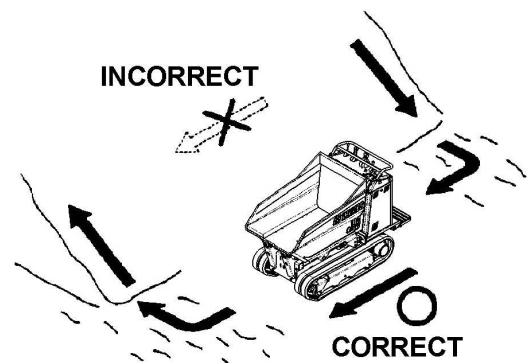

Driving on slopes

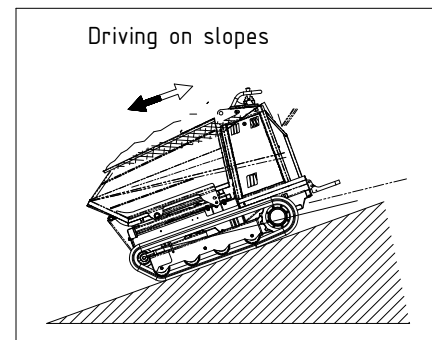

2.1.2 DOUBLE SPEED (Lever C)

Single speed travel

Pull the lever backwards to move at single speed. Use single speed on rough ground or soft surfaces. Single speed is also recommended when loading and unloading the machine from carrier transport.

Double speed travel

Moving the lever forwards, the machine moves at double speed. Use double speed on hard and even surfaces.

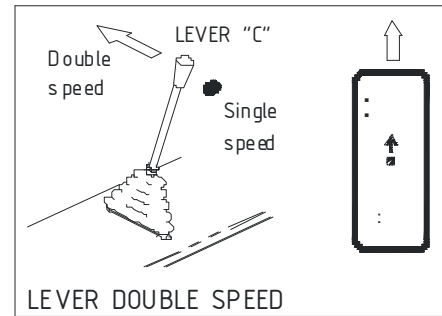

2.1.3 TOOL HOLDER CONTROLS (Lever D)



WARNING

MOVING THIS LEVER BACK WITH THE ENGINE OFF, THE TOOL HOLDER LOWERS UNDER ITS OWN WEIGHT.

To lift the tool holder: Push the lever forwards to lift the tool holder.

To lower the tool holder: Pull the lever backwards to lower the tool holder.

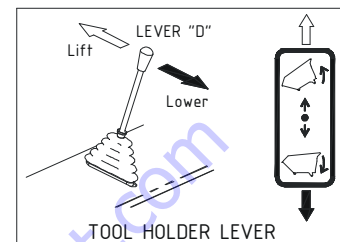

2.1.4 THROTTLE CONTROL LEVER (Lever E)

Decelerator (>): Push the accelerator lever forwards to reduce engine rpm.

Accelerate (:): Pull the accelerator lever backwards to increase engine rpm.

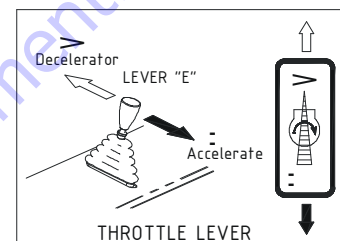

2.1.5 LOADING SHOVEL LEVER (OPTIONAL) (Lever F)

Shovel down: Push the lever forwards to lower the shovel and use it to take up the material.

Shovel up: Pull the lever backwards to lift the shovel and dump.

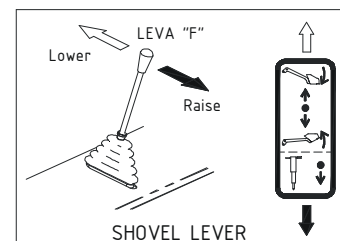

2.1.6 EXTENSION - RETRACTING LEVER (Lever G)

(Applicable for machines fitted with extensible track)

Utilizzare il meccanismo di espansione-contrazione seguendo le procedure qui sotto riportate.

1. Use the spanner mechanism following the procedures described below.
2. Increase engine rpm.
3. Move the "Spanner Lever" forwards or backwards to extend or retract the track.

Track extension: Push the lever forwards.

Track retracting: Pull the lever backwards.

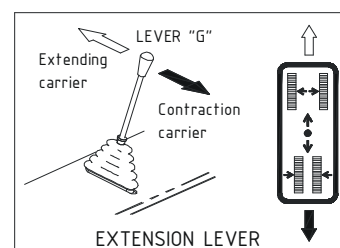

2.1.7 USING THE POWER PORTS FOR MOBILE TOOLS (OPTIONAL) (Lever F)

(Concrete mixer kit, demolition hammer, shear or other)

Using loading shovel lever.

In this case send the shovel to the end of its upward stroke and use the lever lock to supply the tool.

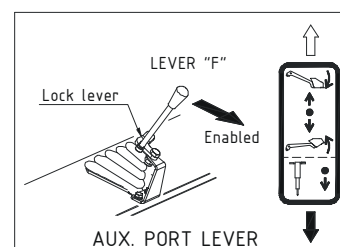

2.1.8 BATTERY CUT-OFF (Switch H)

(Only in the machine with electric start)

OFF Position: Battery power supply is off, all operations are shut off.

ON Position: Battery power supply is on.

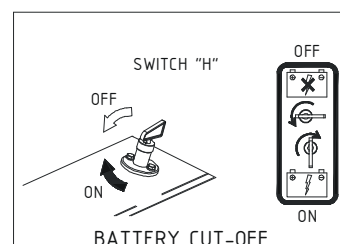

2.2 USE OF THE ENGINE

CHECKS BEFORE STARTING THE ENGINE.

Check the levels of the hydraulic oil, engine oil and fuel.

For the checking methods, refer to the "Daily checks" section of this manual.

This paragraph describes the basic manoeuvres for starting. It is in any case necessary to better familiarize with the procedures described, consulting the engine manufacturer's handbook provided with the machine and contained in the special compartment.

2.2.1 GASOLINE ENGINE STARTING.

1. Turn the fuel valve to the "ON" position.
2. Move the choke lever to the "CLOSE" position.



NOTE: Do not use choke lever if the engine is warm or the air temperature is high.

3. Move the throttle control lever slightly to the left.
4. Start the engine.

- With recoil starter:
turn the engine switch to the "ON" position.
Pull the starter grip lightly until resistance is felt, then pull briskly.

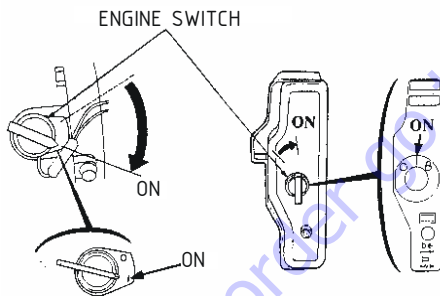
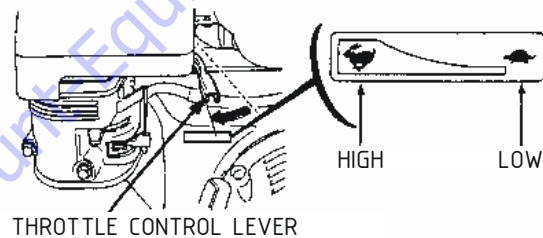

CAUTION:
Do not allow the starter grip to snap back against the engine. Return it gently to prevent damages to the starter.

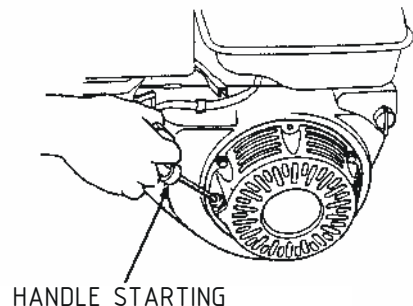

- With electric starter (where equipped):
Turn engine switch to the "START" position and hold it there until the engine start.

NOTE:
Do not use electric starter for more than 5 seconds at a time.
If the engine fails to start, release the key and wait 10 seconds before operating the starter again.
When the engine starts, return the switch to the "ON" position.

2.2.2 SWITCH OFF THE GASOLINE ENGINE

1. Let it rev the motor at **LOW REVOLUTIONS** for few minutes. This allows to motor to get cool gradually before switching off.
2. Switch off the motor referring to what advised by the motor's manufacturer, by reading the appropriate manual, provided in the machine.

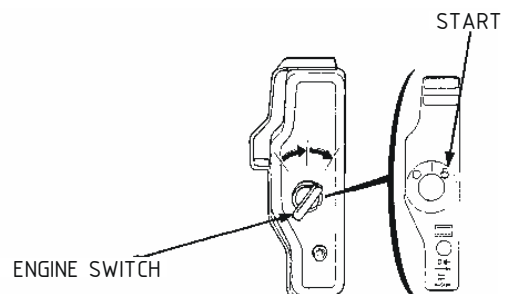

2.2.3 STARTING OF DIESEL ENGINE

1. Check that diesel cock, under the tank, is opened.
2. Put the accelerator lever (E) in the intermediate position.
3. Turn the key (I) in "ON" position. The indicators (N) "oil pressure" and (M) "battery charge" light up.
4. Turn the key (I) in "START" position until the engine starts up. Free the key (I) after start up. The indicators (N) and (M) switch off. Do not operate start up engine more than 15 sec. If the engine does not start up in 15 sec., let cool the engine during 2 minutes before restarting up. Put the key (I) in "OFF" position before retrying to start up.
5. Decrease the engine speed to allow the warming.

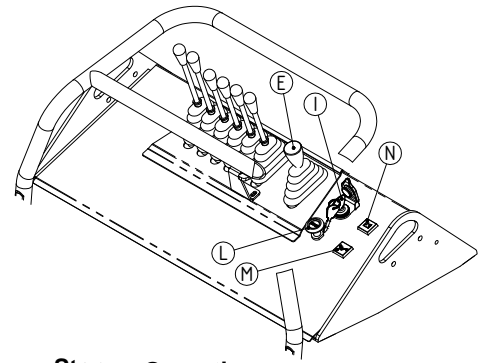

2.2.4 SWITCH OFF DIESEL ENGINE

Put the accelerator lever (E) at minimum speed, put the key (I) in "OFF" position and pull the red button "STOP" (L) till the engine switches off.

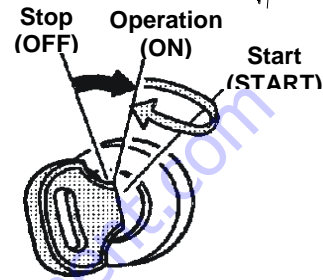

2.2.5 DIESEL ENGINE ELECTRIC SCHEDULE

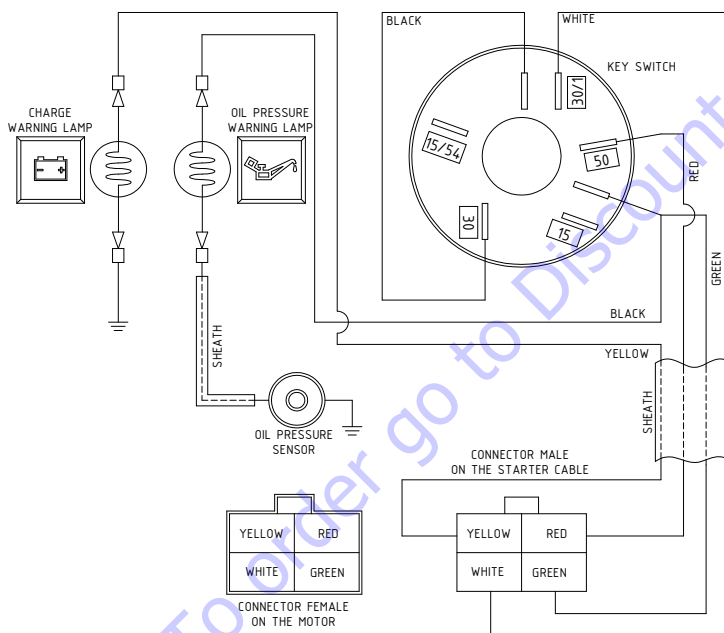

KEY SWITCH

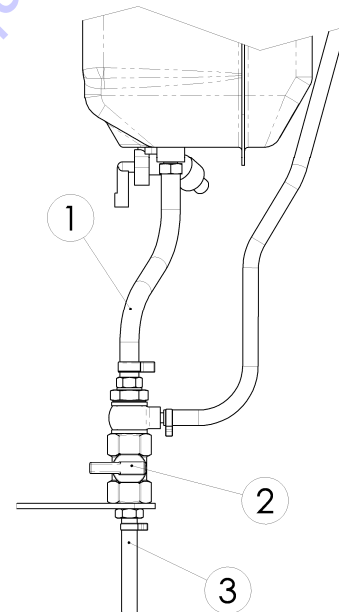

SEDIMENTER

2.2.6 FUEL SEDIMENTER

The fuel tank is equipped with a sedimentation and draining system for water found in the fuel. Any water or other impurities that deposit in the transparent sedimenter (1) are drained through the valve (2). Check and drain out any water and impurities every 50 hours or as needed. Turn the engine off, place a suitable pan under the draining pipe (3), open the valve and let the polluted fuel, water and impurities flow out. Close the valve firmly.

Note: Always dispose of drained fluids as established by local regulations.

2.3 WARMING THE MACHINE

As for all hydraulic systems, it is very important that the oil reach its operating temperature before starting work. The time required for warming can be spent performing a few simple maintenance checks. Before carrying out operations at full load carefully follow the instructions given below:

- 1 Allow the engine to warm up slowly at low speed for 5 minutes.
- 2 Operate the tool holder cylinder to warm the hydraulic components quicker.

2.4 LIFTING THE MACHINE



WARNING

- USE APPROPRIATE CABLES AND TOOLS FOR LIFTING. LIFTING CABLES MUST HAVE SUFFICIENT LENGTH TO AVOID CONTACT WITH THE MACHINE.
- USE HOISTING EQUIPMENT ABLE TO SUPPORT THE WEIGHT OF THE MACHINE.
- **NEVER LIFT THE MACHINE WITH ANY PERSONNEL ON BOARD.**
- USE NOTICES AND OTHER SIGNS TO MARK OFF THE LOADING AREA.
- USE ALWAYS CABLES AND OTHER TOOLS WITH CON BREAKING LOADS ABOVE TO 4T.

LIFTING PROCEDURES

The machine is provided with 4 hooking points marked by special labels. Two near the driving levers and the others on the LH. undercarriage and RH. undercarriage.

1. Position the machine on level ground with the bucket, or dumper or deck lowered and the blade up.
2. Stop the engine.
3. Connect the slings to the 4 lifting points through 4 shackles of suitable capacity.
4. Connect the cables to the lifting device hook.
5. Make sure there are no obstacles or persons around the machine
6. Lift the machine a few centimetres off the ground and check that it is well balanced.

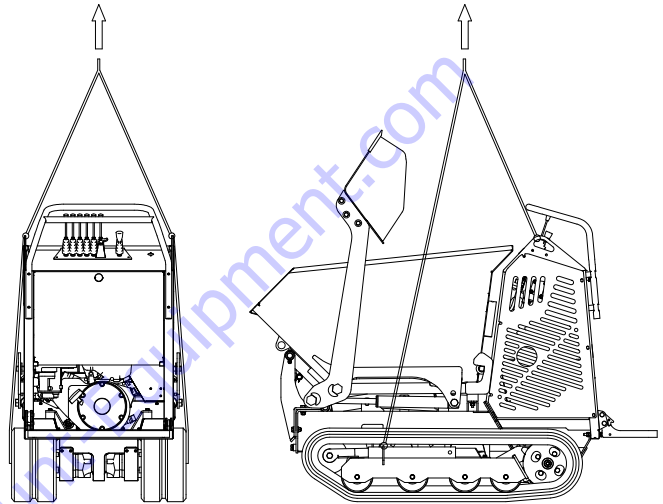

2.5 LOADING AND UNLOADING THE MACHINE



WARNING

- IF POSSIBLE, LOAD AND UNLOAD THE MACHINE ON LEVEL AND FIRM GROUND.
- USE A RAMP OF ADEQUATE LENGTH, WIDTH AND THICKNESS TO SUPPORT THE WEIGHT OF THE MACHINE.
- TO PREVENT THE MACHINE FROM SLIPPING ON LOADING RAMPS OR MOVING DURING TRANSPORT, CLEAN THE TRUCK DECK AND RAMPS OF GREASE, OIL, ICE OR ANYTHING ELSE BEFORE LOADING THE MACHINE.
- **NEVER OPERATE AT DOUBLE SPEED WHEN LOADING OR UNLOADING THE MACHINE.**
- **NEVER MAKE A TURN ON LOADING RAMPS. IF NECESSARY, MOVE OFF THE RAMP TO CHANGE THE DIRECTION OF TRAVEL.**

MACHINE LOADING ONTO A TRUCK

ALWAYS use ramps to load and unload the machine and carefully follow the procedure given below.

1. Chock the truck wheels before loading the machine.
2. Lower the truck tailboard.
3. Secure the loading ramps to the truck. The ramps must form an angle with the ground of within 15°. The ramp width must be suited to the tracks.
4. Position the machine so that it can be run straight onto the loading ramps. Never operate control levers other than the travel levers while the machine is on loading ramps.
5. Maintain the machine balance point within the loading ramp area.
6. Make sure the ramps are stable.

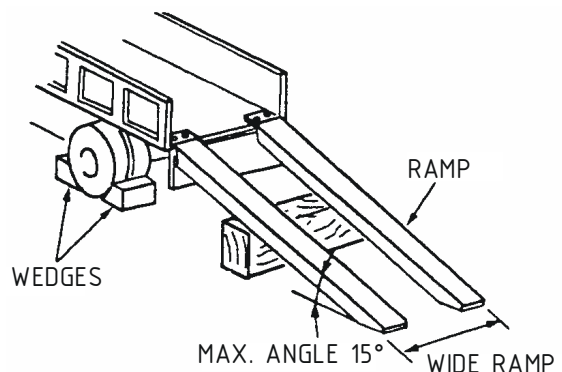

FIXING FOR TRANSPORT

1. Switch off the engine.
2. Fasten the tracks and secure the machine to the truck using chains or steel cables.

2.6 ATTACHMENTS

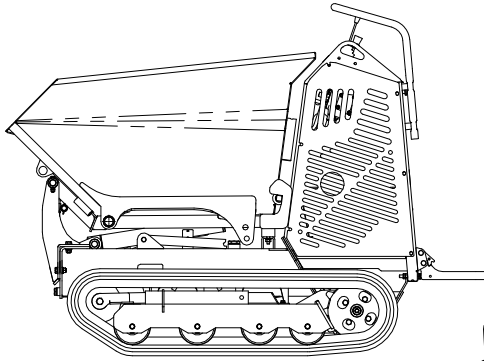

BUCKET

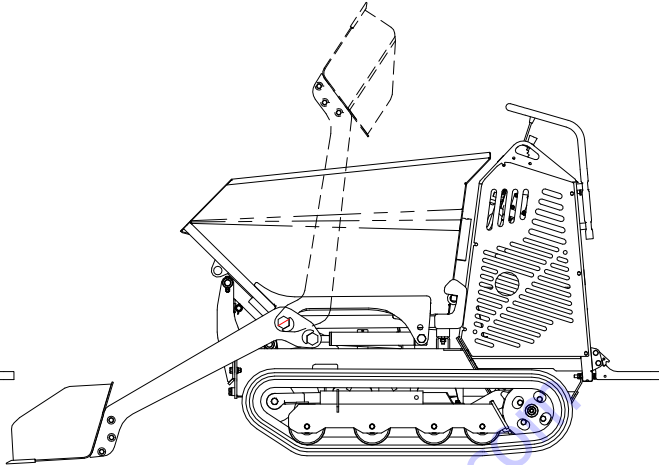

BUCKET WITH SHOVEL

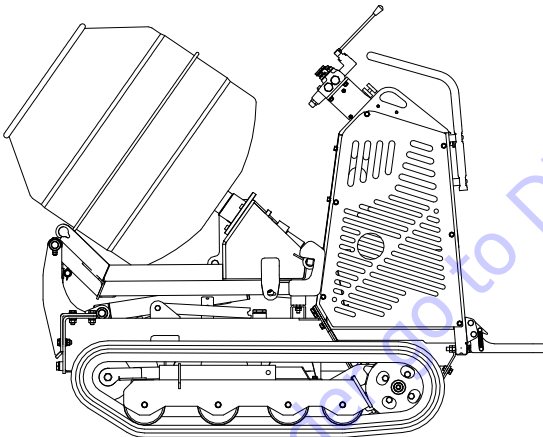

CONCRETE MIXER KIT

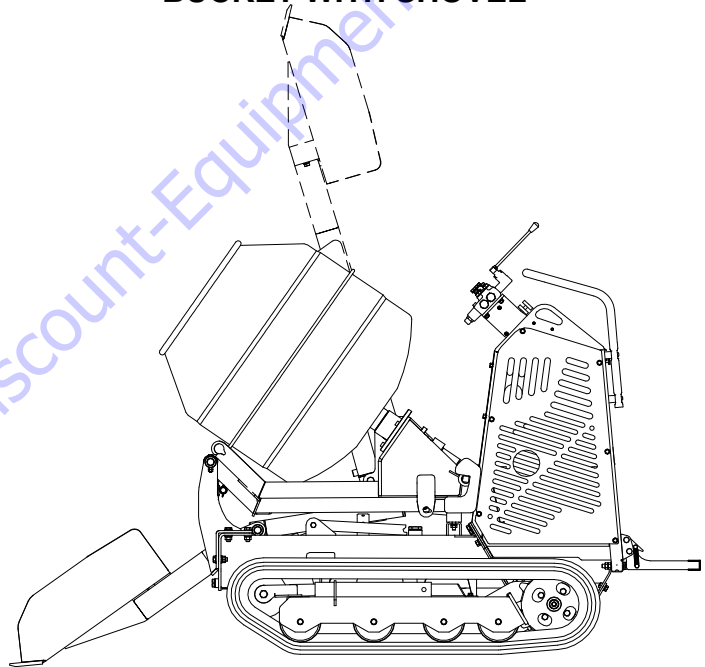

CONCRETE MIXER KIT WITH SHOVEL

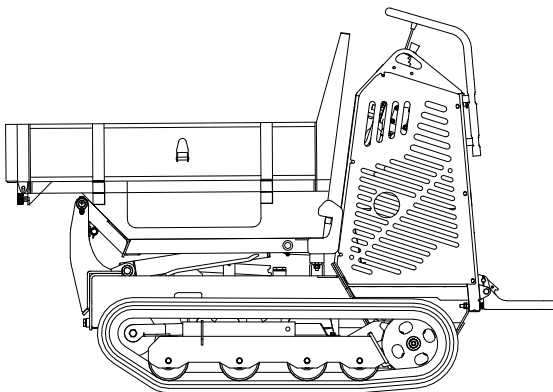

PLATFORM

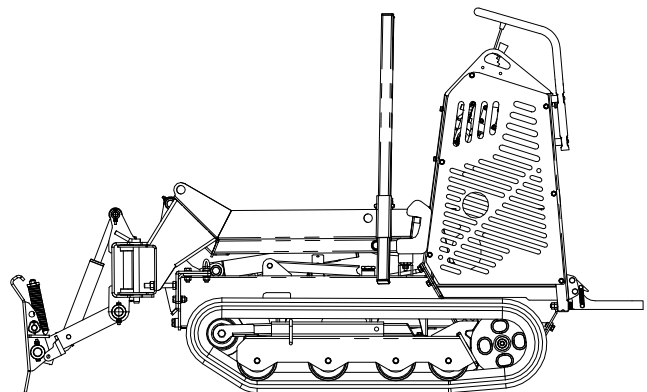

GRADER BLADE KIT

2.7 ACCESSORIES AND THEIR USE

2.7.1 BUCKET

The 0.33 m³ bucket is the most suitable accessory for carrying debris, earth, sand, gravel, miscellaneous aggregates, conglomerates, concrete, lime and in any case all materials that may be used for site activities. The bucket can be combined with the self-loading shovel. Once the bucket is filled, drive the machine to the place of unloading and carry out the necessary manoeuvres as described in point 2-1-3.

If the machine has not provided of the self-loading shovel during the unloading, take the bucket in the most high position.

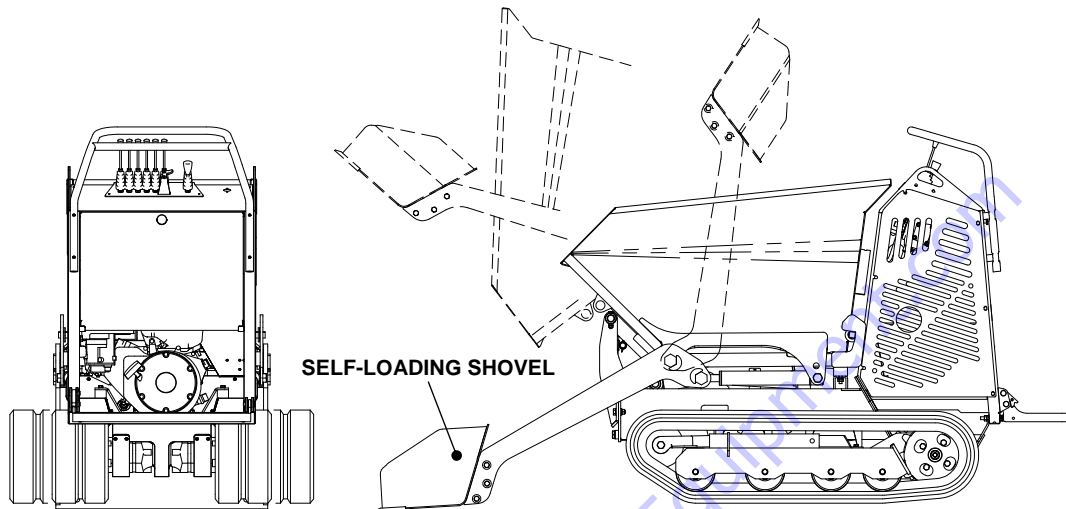

2.7.2 SELF-LOADING SHOVEL



WARNING

CLEAR THE WORKING AREA OF PEOPLE BEFORE ACTIVATING THE SHOVEL.

Self-loading shovel is linkable to the bucket and to the deck; it can be used only to load debris or moved material. IT IS ABSOLUTELY FORBIDDEN TO DIG.

To load:

- Position the shovel on the ground.
- Operate the machine approaching it slowly to heap, until filling up completely.
- Lift the machine, by reducing the speed, when material unloading begins, in order to avoid material out of the accessory and on the driver seat.

2.7.3 PLATFORM

The platform is an accessory suitable to various uses in the transport in the building, agricultural, seedling nursery or civil fields. The folding panels in the version "all opened", permits to have a platform suitable to carry long dimension plates or panels. A large open space under the loading floor, is used to carry belts, ropes and various tools.

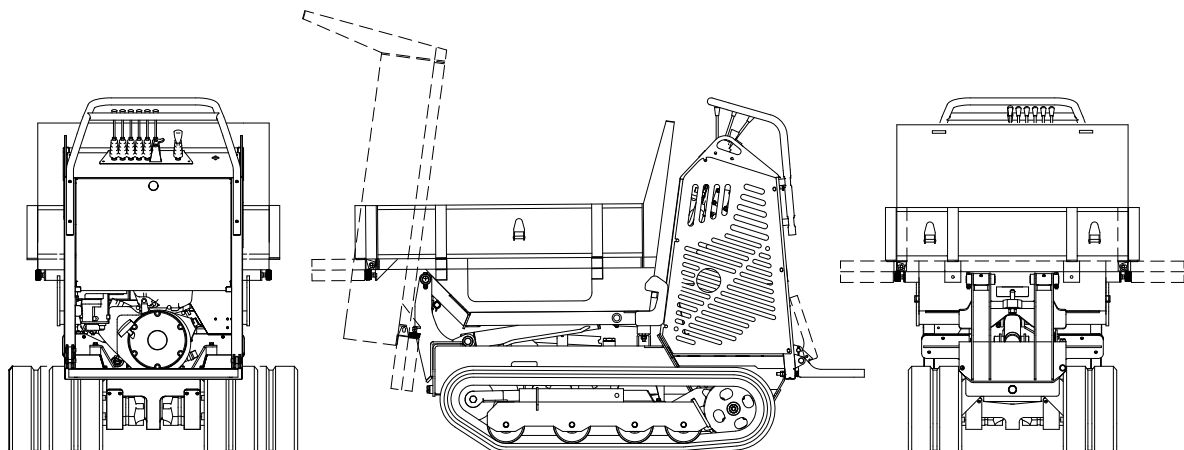

2.7.4 CONCRETE MIXER KIT

Concreting kit consists of a 250 lt. mixing vat, operated by an oleo dynamic motor. It is suitable to mix building conglomerate, concrete or lime; composite mould or similar in seedling nursery field; fodder and similar in agricultural field.

To obtain homogeneous mixings it is advised a rotation rating of the vat of about 24/25 revolution/min. to be obtained by governing motor revolutions or by means governing of a standard valve.

Concreting kit can be installed only on predisposed machines with AUXILIARY power take-off

Loading in a defined place, mixing during travel and unloading of amalgamated material in a place even far, make that accessory particularly versatile.

To unload do necessary manoeuvres, as indicated in 2-1-3.

It is linkable at self-loading shovel, useful also as conveyor during unloading.

TAKE CARE WITH THE POSITION OF THE SHOVEL DURING UNLOADING.

To carry out shovel loading, use the "shovel control lever" located next to the operator handle, following the instructions given below:

- Take the shovel on the ground.
- Operate the machine approaching it slowly to heap, until filling up completely.
- Lift the machine, by reducing the speed, when material unloading begins, in order to avoid material out of the accessory or on the driver seat.

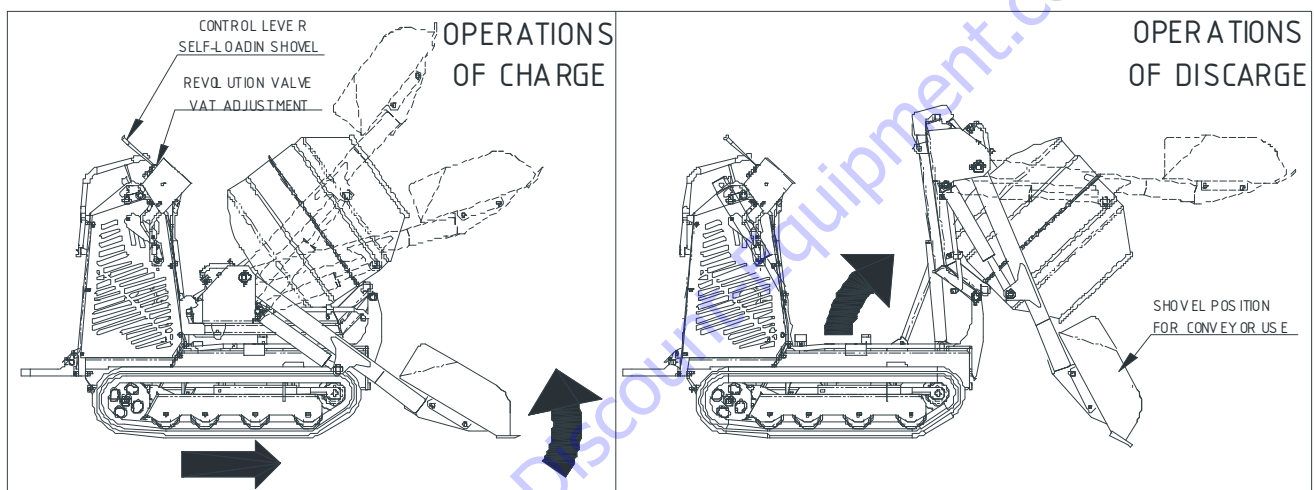

2.7.5 FOOTBOARD

The footboard is hinged to the driving frame. In the closed position it allows safe driving from the ground avoiding the danger of contact with the driver's legs. In the open position the operator can drive on board. A shock absorbing system reduces the vibrations transmitted to the lower limbs. For complete operator safety, the footboard is fitted with a clamping system (with spring retention) that prevents accidental closing.

2.7.6 USE OF THE AUXILIARY POWER PORTS

(Oil displacement 14 l/min.)

The ports of the auxiliary power take-off are located on the right hand of the machine and protected by a cover.

For an easy use, please install quick hydraulic couplings size $\frac{1}{4}$ M and $\frac{1}{2}$ F. To install the quick couplings, it is necessary to depressurize the hydraulic circuit by loosening the oil fill cap of the machine, removing the ports plugs and screw on the quick couplers with the appropriate washers.

To pressurize again the hydraulic circuit, extend all the cylinders and tighten the oil fill cap. (see point 3.7).

The oil flow is obtained by moving the lever F (shovel control lever) and blocking it in position with the holder (see point 2.1.7).

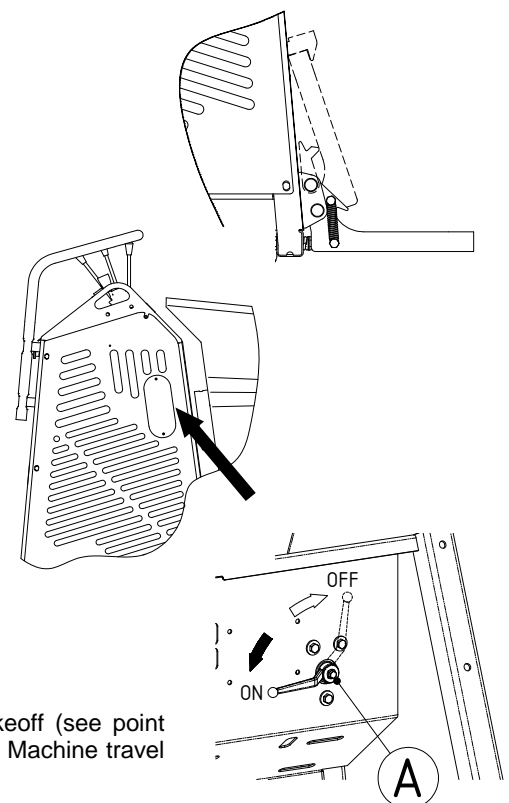

2.7.7 USE OF THE AUXILIARY POWER PORTS HI FLOW (OPTIONAL)

(Oil displacement 26 l/min.)

The HI FLOW kit uses the same terminals as the standard AUX power takeoff (see point 2.7.6). For complete flow rate delivery turn lever (A) as shown in the diagram. Machine travel is not possible during use of the HI FLOW power takeoff.

2.7.8 GRADER BLADE USER INSTRUCTIONS (OPTIONAL ACCESSORY)

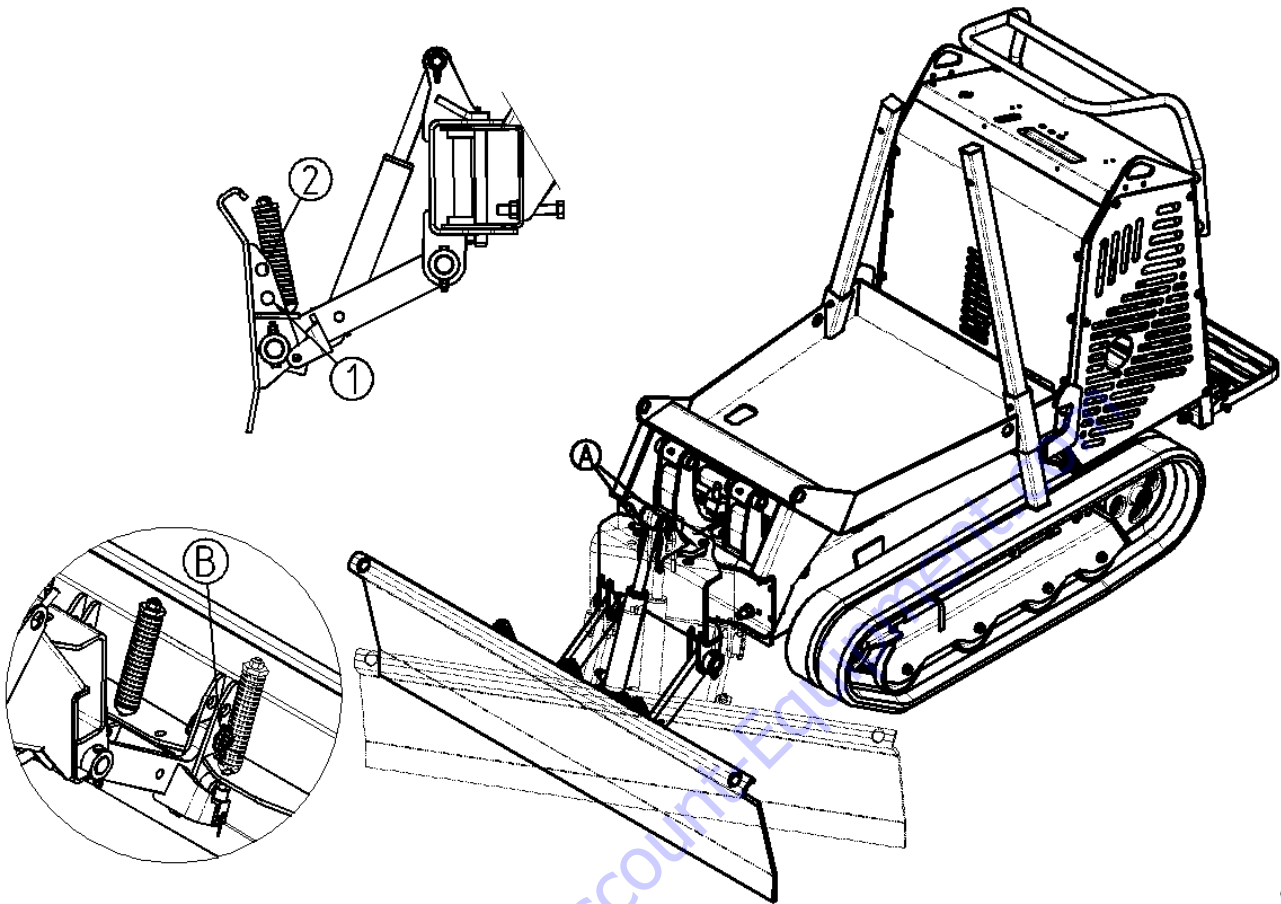

- Make sure the blade is secured against the rocker by fitting the pins (B) into the holes (1). Adjust the height of the blade with lever F (ref. § 2.1).
- The blade can work horizontally or angled sideways by 30° on either side. Lock it into the selected position with the two pins (A).
- Never leave the blade in the raised position. Always leave the blade resting on the ground when not using it or when leaving the vehicle for any period of time.

2.7.9 USING THE GRADER BLADE AS A SNOW PLOUGH (OPTIONAL ACCESSORY)

- Make sure the blade is free to rock during operation. Remove the pins (B) from seat (1) and fit them into seat (2). The rocker allows the blade to pass over small obstacles such as protruding manhole covers during operation, thus avoiding impact stress to the machine and operator. The springs return the blade to its working position once the obstacle has been passed. Adjust the height of the blade with lever F (ref. § 2.1).
- The blade can work horizontally or angled sideways by 30° on either side. Lock it into the selected position with the two pins (A).
- The bin allows the operator to transport tools and bags of salt. The additional weight also stabilises the machine and improves its performance.
- Never leave the blade in the raised position. Always leave the blade resting on the ground when not using it or when leaving the vehicle for any period of time.

2.7.10 INSTRUCTIONS FOR SELF-LOADING SHOVEL ASSEMBLY. (OPTIONAL)

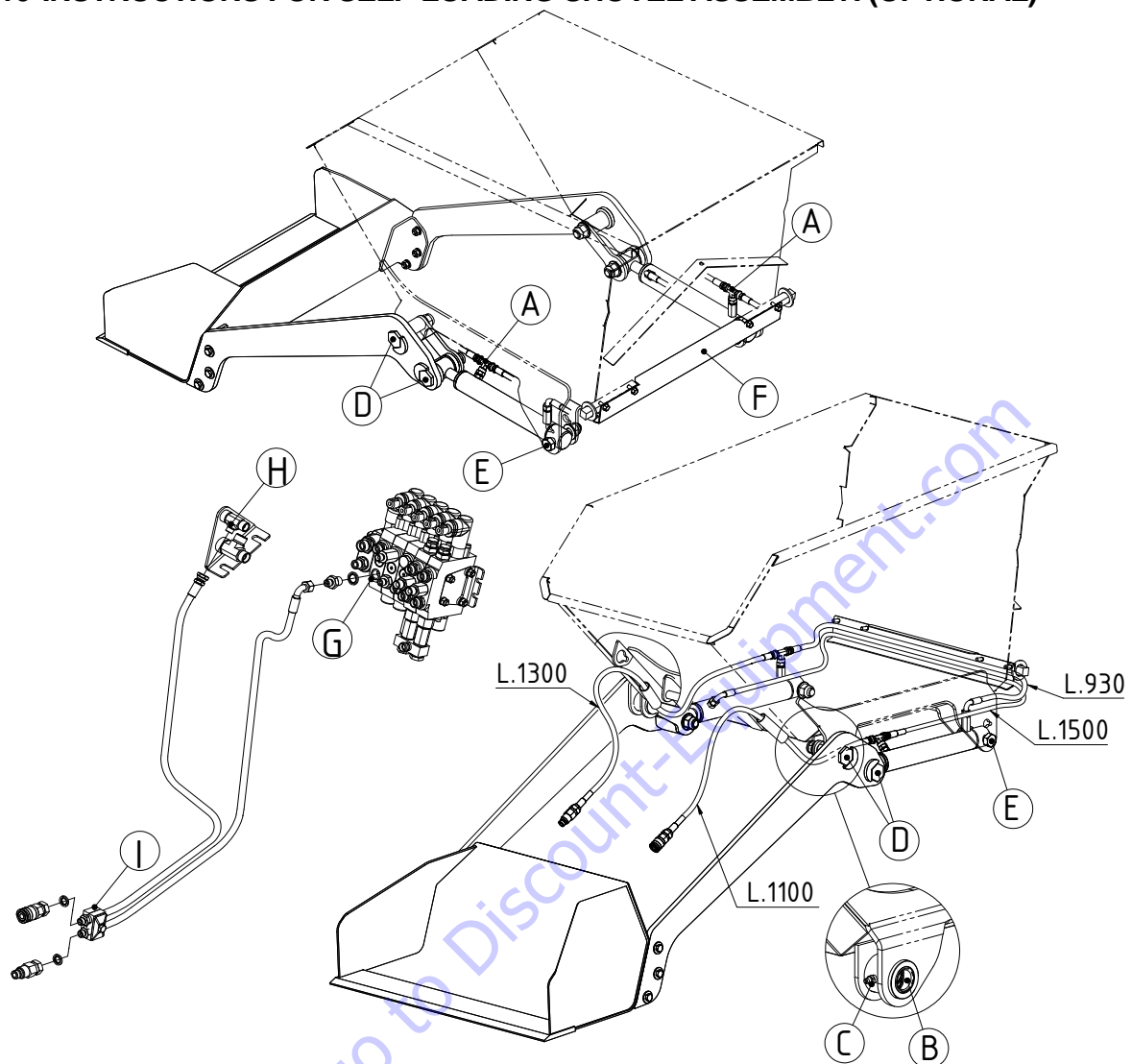

- 1 Fit the union tees (A) on the cylinders. Right-hand cylinder with union on bottom connector, left-hand cylinder with union on top connector.
- 2 Insert the steel bushings (B) in the bucket and fit the greasing nipple (C). **WARNING** use special tools to insert the bushings. **WARNING** do not use hammers or blunt objects; the welded supports on the bucket might buckle, compromising the whole assembly.
- 3 Fit the shovel arms on the bucket using the hexagon head pins (D). Fully tighten the self-locking nut on the pin.
- 4 Fit the cylinders on the arms (right-hand cylinder on right-hand arm and vice versa) using the special hexagon head pins (D) and fully tightening the self-locking nut on the pin.
- 5 Fit the hydraulic pipes on the cylinders following the length indications. Pass the hydraulic pipes L=1100 mm and L=1300 mm in the special bucket guides; then fit the female quick coupling on the pipe L=1100 mm and the male quick coupling on the pipe L=1300 mm using the special seal washers.
- 6 Fit the cylinders on the bucket using the screws (E) and self-locking nuts. **DO NOT LOCK** the nuts fully home; the cylinder must be free to turn.
- 7 Fit the shovel taking care to avoid play in the coupling with the arms.
- 8 Fit the pipe cover (F) on the back of the bucket using the special screws. Take care in positioning the pipes.
- 9 Remove the bucket end front cover of the machine, slacken the oil filler plug to depressurise the system.
- 10 Connect the pipe L=1000 with bend to the distributor (Port G) using the nipples and seal provided. Fit the male quick coupling to the other end.
- 11 Connect the pipe L=1000 with straight female terminal to the auxiliary bracket (H). Fit the male quick coupling to the other end.
- 12 Clamp the pipes to the frame using the support provided (I) positioning the bridge on the pipe steel sleeve.
- 13 Tighten the oil tank plug and carry out the pressurising operations, then refit the cover on the machine.

2.7.11 ASSEMBLY INSTRUCTIONS FOR CONCRETE MIXING KIT SELF-LOADING SHOVEL. (OPT.)

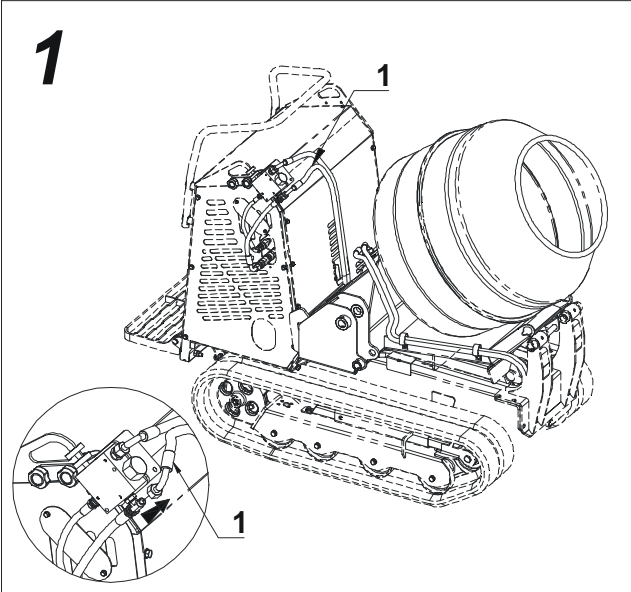
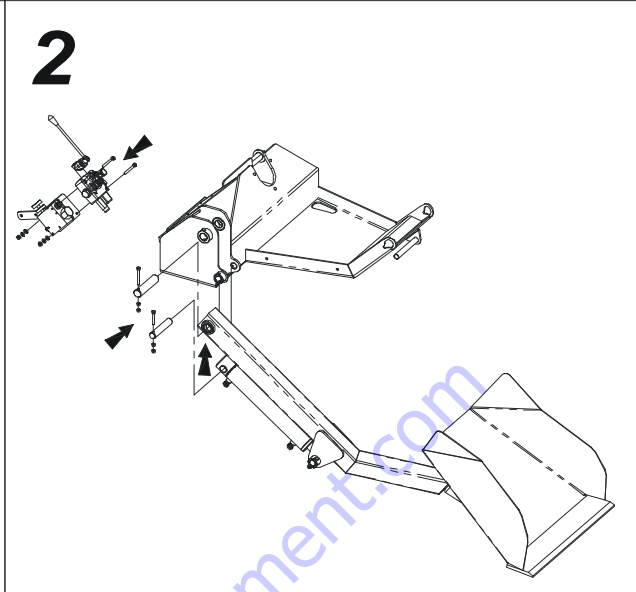
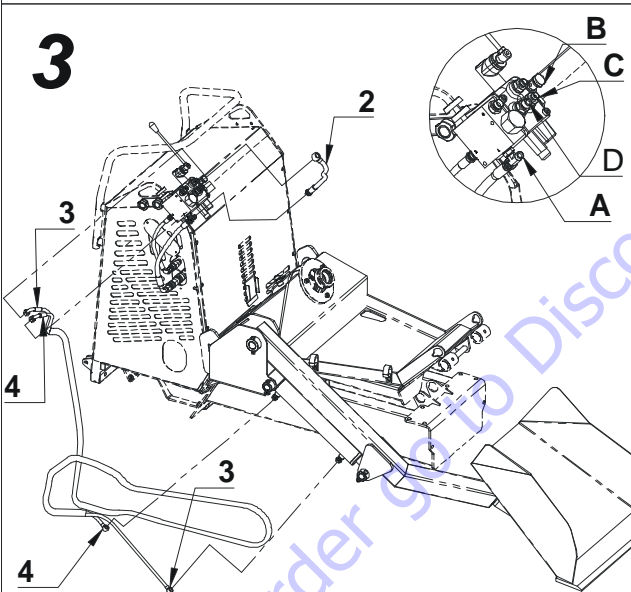
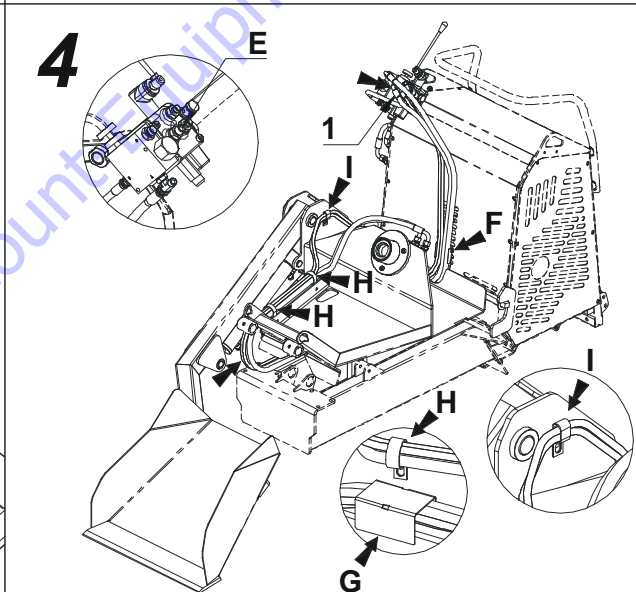
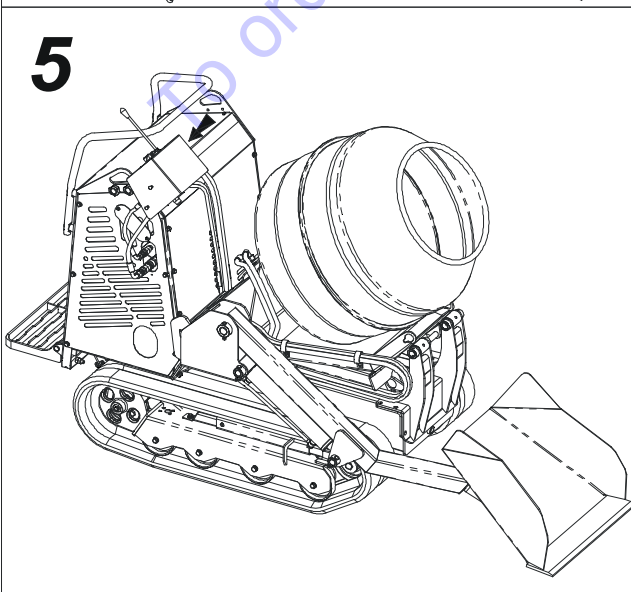
| | |
|---|---|
| <p>1</p>  | <p>2</p>  |
| <p>3</p>  | <p>4</p>  |
| <p>5</p>  | <ol style="list-style-type: none"> 1) Remove the protective cover from the concrete mixing kit control panel and disconnect the pipe (1) from the union tee. 2) Assemble the arm and cylinder on the concrete mixer frame using the special pins and screws. Fasten the distributor to the panel using the screws provided. 3) Connect pipe (2) in position (A) of the union tee on the valve and in position (B) on the shovel distributor. Connect the sheathed pipes (3) L=3600 in position (C) and pipe (4) L=3400 in position (D) on the distributor. 4) Lock the pipes (3) e (4) together with the already existing concrete mixer pipes to brackets (F) and (G) and to clamps (H) and (I). WARNING! Divide the mixer and shovel pipes after clamp (H) making them each follow their own routing. Connect pipe (3) to the head and pipe (4) to the bottom of the shovel piston. Connect pipe (1) in position (E) on the distributor. 5) Reposition the protective cover of the concrete mixing kit control panel. |

2.7.12 INSTALLING THE HI FLOW AUXILIARY PTO. (OPTIONAL)

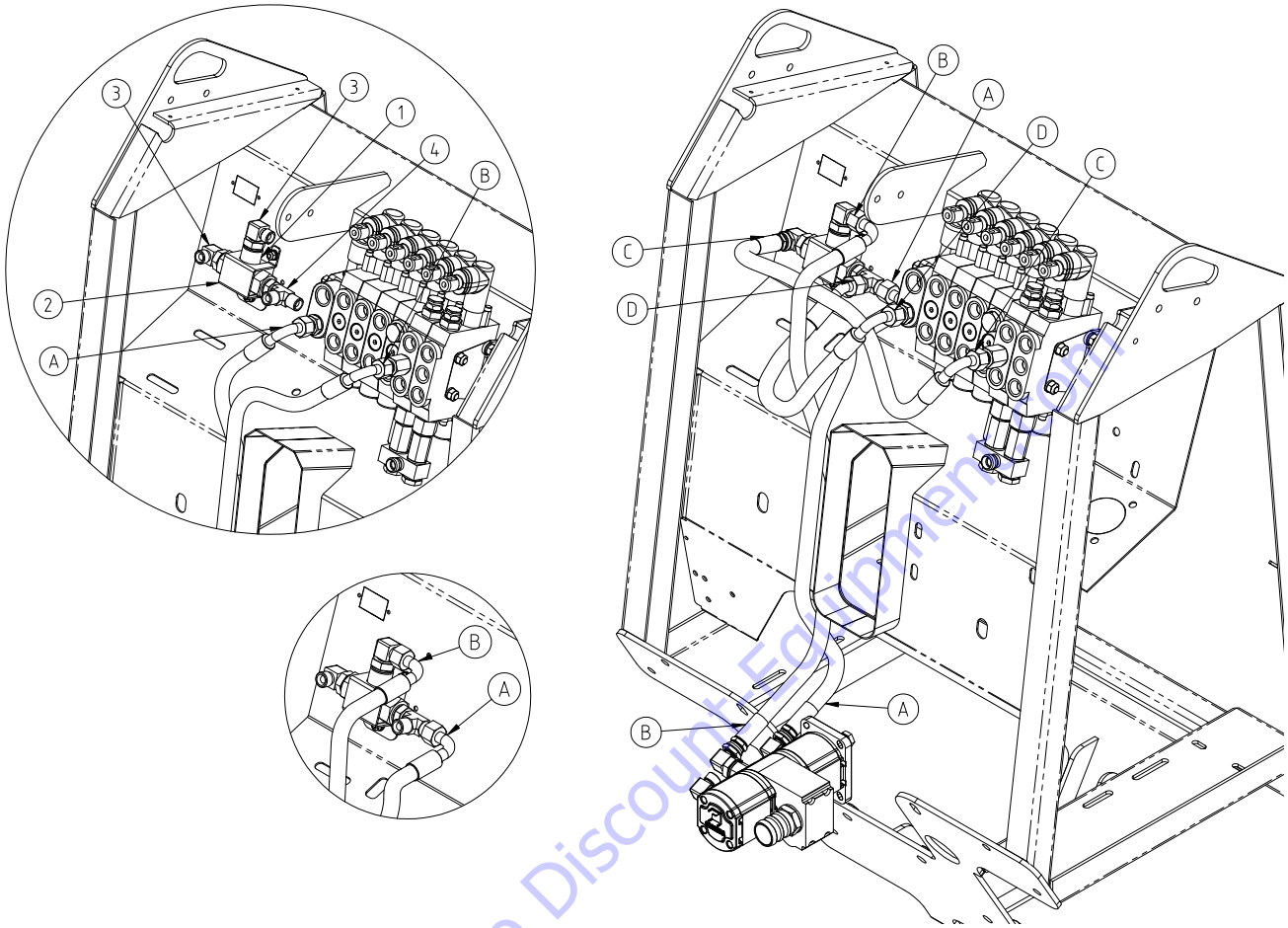

Remove the front housing on the bin side, and unscrew the oil filler cap to depressurise the hydraulic circuit. Mount fittings (3) and (4) to the hydraulic junction (1). Fit the hydraulic junction to its mounting point with the bracket (2) and the provided bolts, washers and nuts. Disconnect hoses (A) and (B) from the manifold and connect them to the hydraulic junction. Connect hoses (5) and (6) from the hydraulic junction to the manifold. Make sure the hoses are securely installed. Repressurise the hydraulic circuit (ref. § 3.4.2). For information on operating the "Hi-flow PTO", refer to § 2.7.67. Reinstall the machine's front housing.

2.7.13 PARKING BRAKE

The parking brake is mounted on the frame of the right track and when it is activated it engages the teeth of the driving wheel. Hydraulic control operation is automatic and allows the brake to be engaged every time the machine comes to a stop.

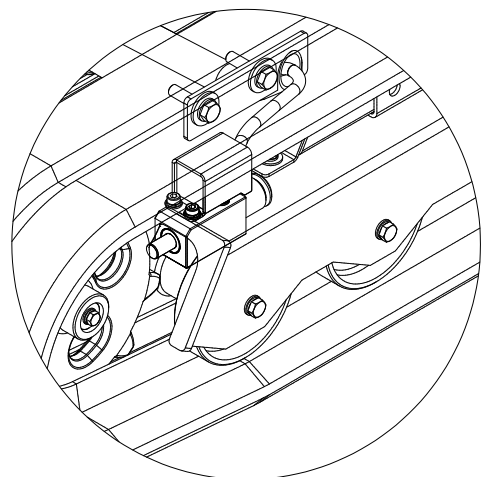

2.8 REPLACEMENT PROCEDURE OF ACCESSORIES

2.8.1 PROCEDURE OF RELEASE-LINK-UP OF ACCESSORIES



WARNING

IN ORDER TO AVOID ACCIDENTS, PARTICULARLY WHEN THERE ARE FORCED LOCKING, WE ADVISE TO USE THE KEY TO PROCEED WITH RELEASE – LINK-UP OF ACCESSORIES.

The unhook of accessory can be done by means a supplied key. This avoid any probable accident. Unscrew the nut (A) till make free the coupling (B) from block stirrup (C). Remove later the accessory from the tool support.

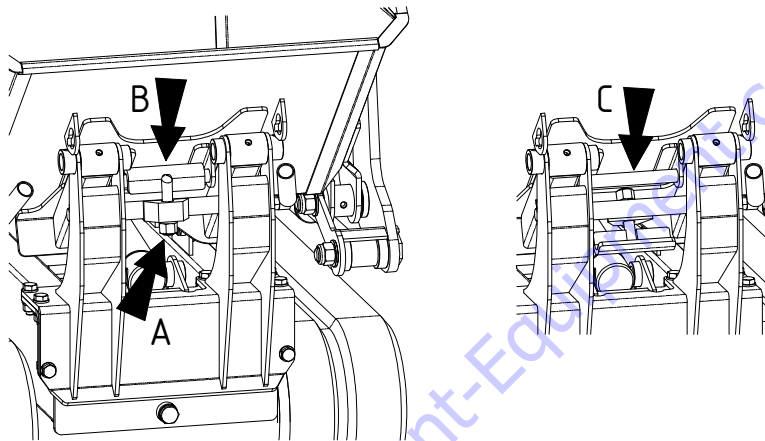

The bucket and platform accessories can be removed by hand by two persons. For the bucket with shovel and concrete mixer kit, the use of a hoisting device or special gantry is necessary (ref. § 2.8.3–2.8.4–2.8.5). To install a new accessory reverse the sequence of the operations carried out.

2.8.2 ACCESSORY FITTING AND CLAMPING PROCEDURE

Position the accessory in the boom taking care to insert the accessory rear pins in the special brackets of the boom (D). Insert the coupling (B) on the clamping bracket and tighten nut (A) fully home.

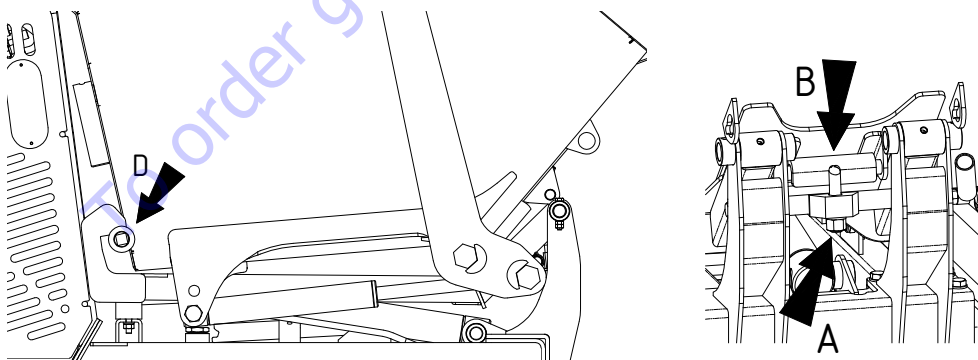

2.8.3 INSTRUCTIONS FOR BUCKET LIFTING WITH SHOVEL OR CONCRETE MIXER KIT

USE STEEL CABLES WITH MINIMUM CAPACITY of 300 Kg.

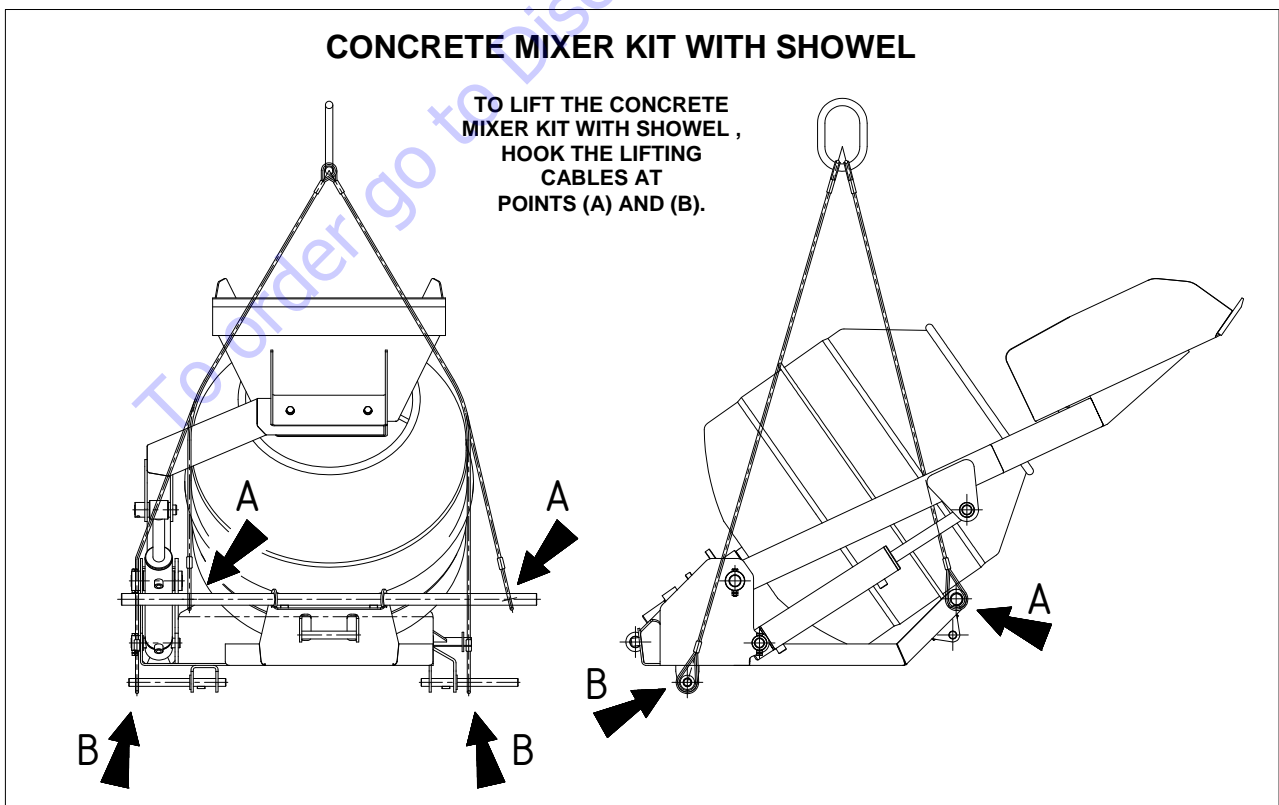
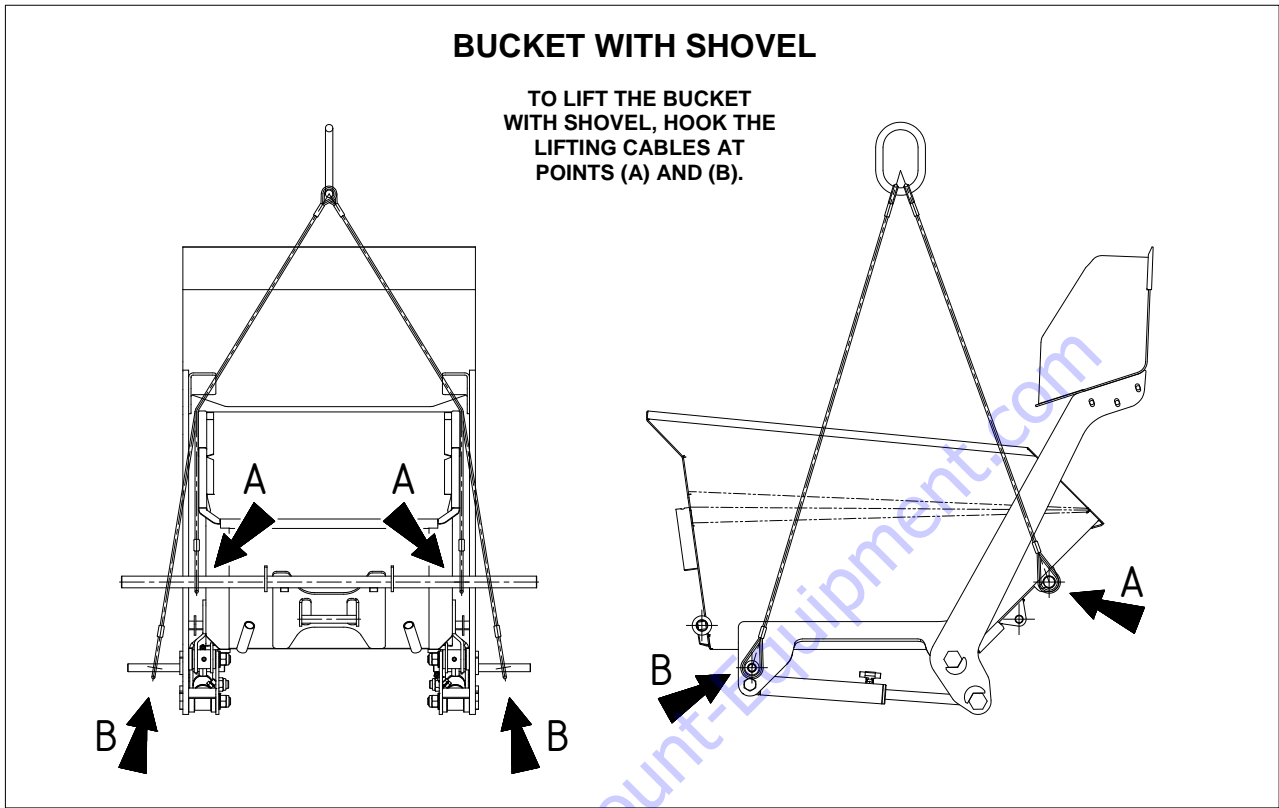

2.8.4 INSTRUCTIONS FOR ACCESSORY RELEASE BY USING LIFTING JACK

- 1 RAISE THE SHOVEL TO THE END OF ITS STROKE

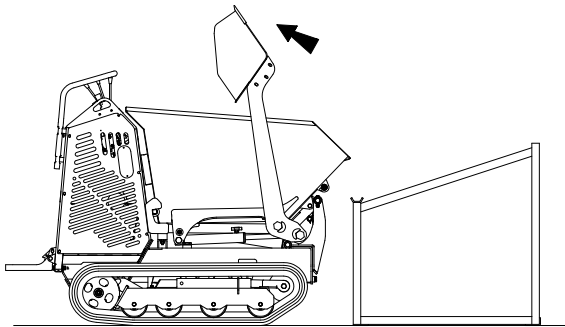

- 2 OVERTURN THE ACCESSORY AND DISCONNECT THE FLUID POWER PIPES THROUGH THE SPECIAL QUICK COUPLINGS.

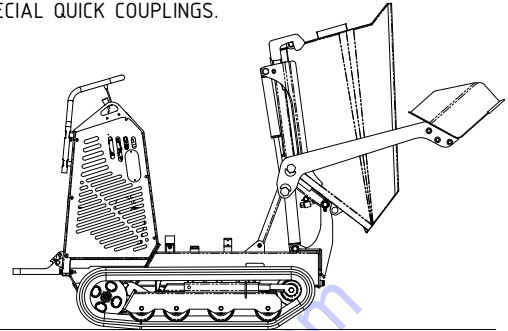

- 3 QUICK COUPLINGS ON THE MACHINE.
QUICK COUPLINGS ON THE SHOVEL.

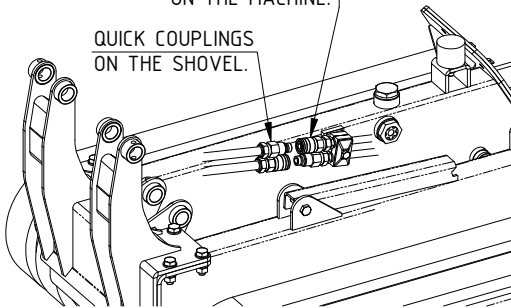

- 4 LOWER THE ACCESSORY COMPLETELY.
INSERT THE RESTING PINS AND LOCK THEM TURNING 90°.

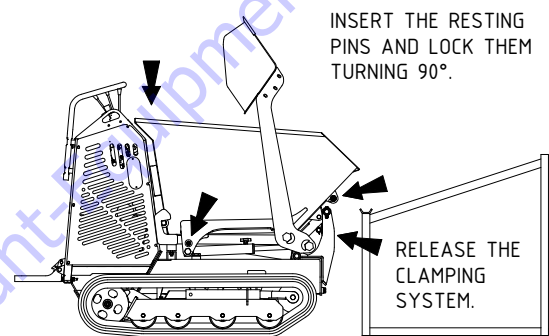

- 5 CAREFULLY APPROACH THE GANTRY KEEPING CENTRED UNTIL THE FRONT PIN RESTS ON THE STRUCTURE.

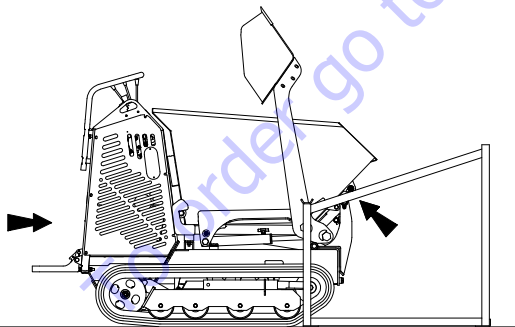

- 6 MOVE FORWARDS SLOWLY LIFTING THE BOOM FRAME AT THE SAME TIME TO TAKE THE PINS ABOVE THE SPECIAL RESTS.

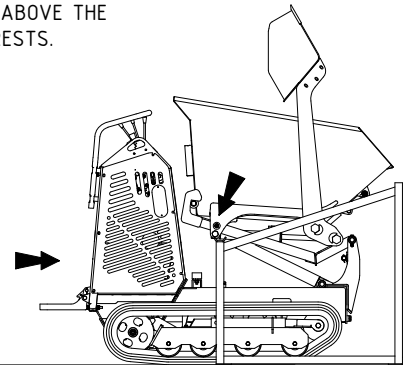

- 7 LOWER THE BOOM FRAME UNTIL THE PINS ARE POSITIONED ON THE SPECIAL RESTS (A).

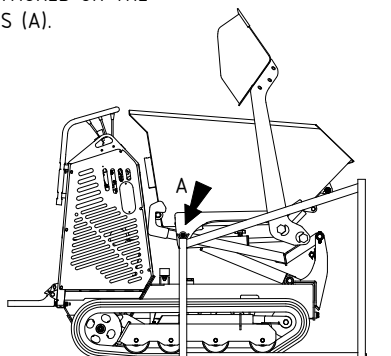

- 8 MOVE BACKWARDS SLOWLY RELEASING THE BOOM FRAME FROM THE ACCESSORY AND THE MINIDUMPER FROM THE GANTRY.

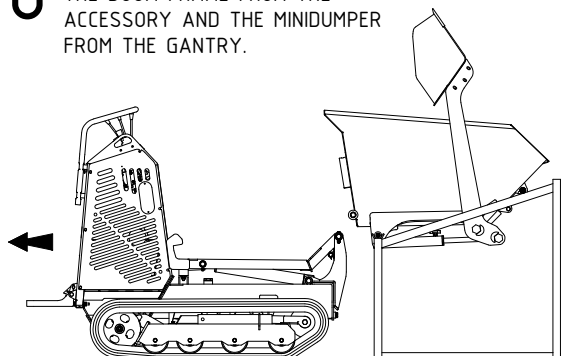

2.8.5 INSTRUCTIONS FOR ACCESSORY LINK-UP BY USING LIFTING JACK

- 1** CAREFULLY APPROACH THE GANTRY KEEPING CENTRED WITH THE STRUCTURE.

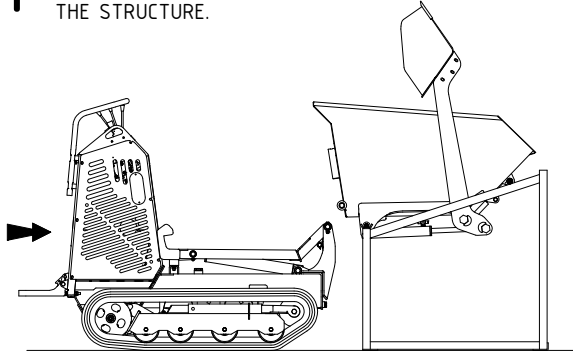

- 2** RAISE THE BOOM FRAME UNTIL COUPLING THE ACCESSORY.

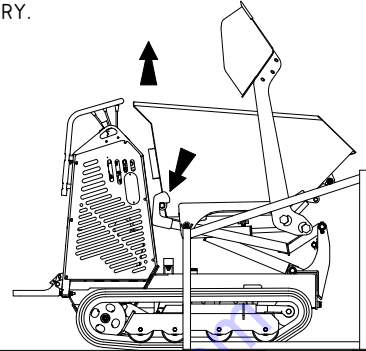

- 3** RAISE THE ACCESSORY TO RELEASE THE RESTING PINS.

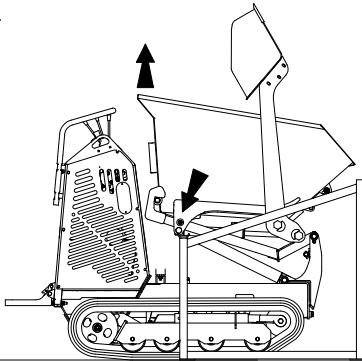

- 4** MOVE BACKWARDS SLOWLY UNTIL THE ACCESSORY RESTS ON THE BOOM FRAME.

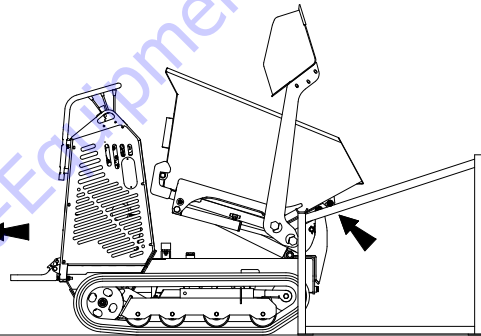

- 5** MOVE OUT OF THE GANTRY AND LOWER THE ACCESSORY.

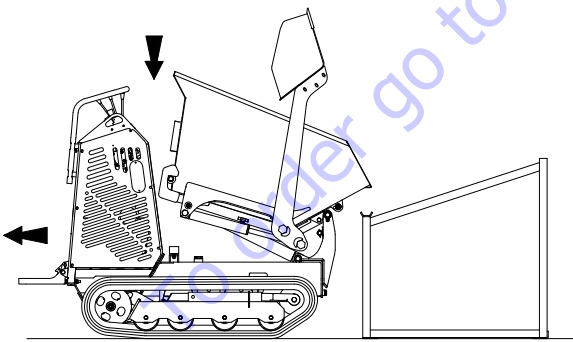

- 6** LOWER THE ACCESSORY COMPLETELY.

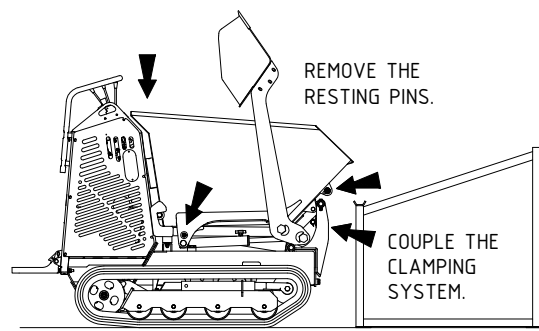

- 7** OVERTURN THE ACCESSORY AND CONNECT THE FLUID POWER PIPES THROUGH THE SPECIAL QUICK COUPLINGS.

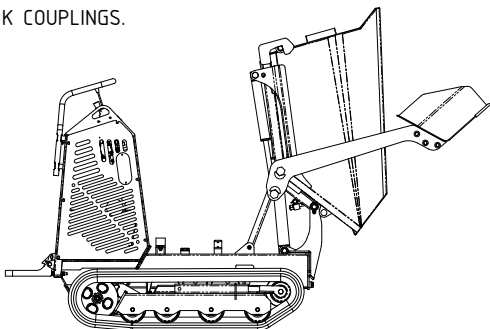

- 8** QUICK COUPLINGS ON THE MACHINE.

QUICK COUPLINGS ON THE SHOVEL.

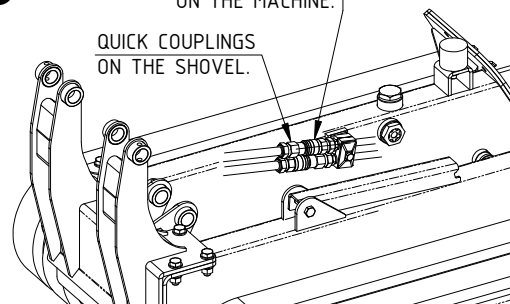

2.8.6 INSTRUCTIONS FOR CONCRETE MIXER KIT RELEASE BY USING LIFTING JACK

- 1** RAISE THE SHOVEL TO THE END OF ITS STROKE.

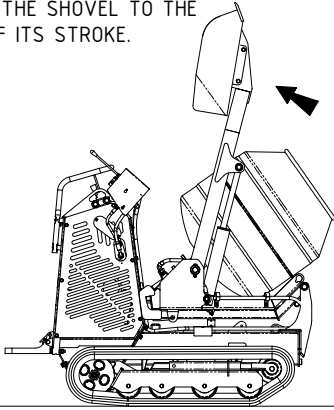

- 2** RAISE THE ACCESSORY, RELEASE THE TWO PIPE STOPPER BRACKETS FROM THE MACHINE FRAME AND LOWER THE ACCESSORY.

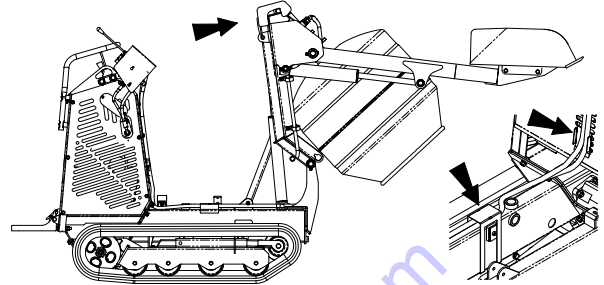

- 3** DISCONNECT THE FLUID POWER PIPES THROUGH THE SPECIAL QUICK COUPLINGS, REMOVE THE CONTROL PANEL TAKING OFF THE TWO LOCKING KNOBS "A". POSITION THE CONTROL PANEL ON THE ACCESSORY FRAME.

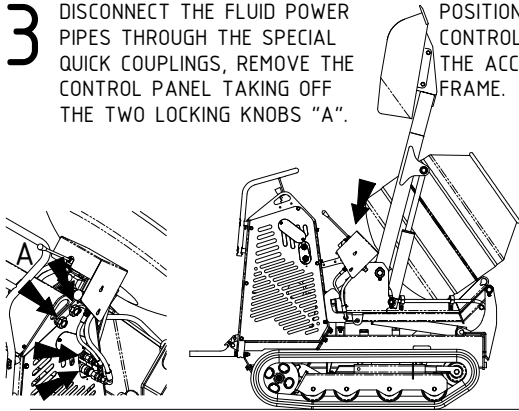

- 4** LOWER THE ACCESSORY COMPLETELY.

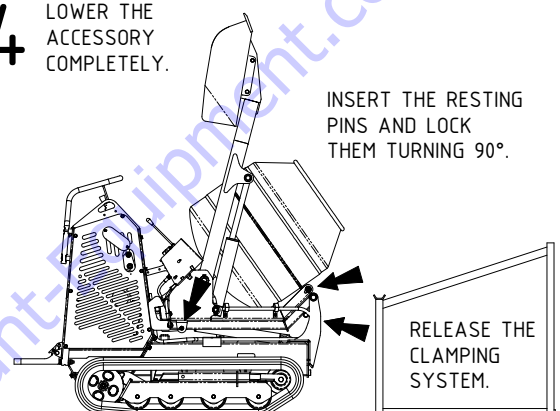

- 5** CAREFULLY APPROACH THE GANTRY KEEPING CENTRED UNTIL THE FRONT PIN RESTS ON THE STRUCTURE.

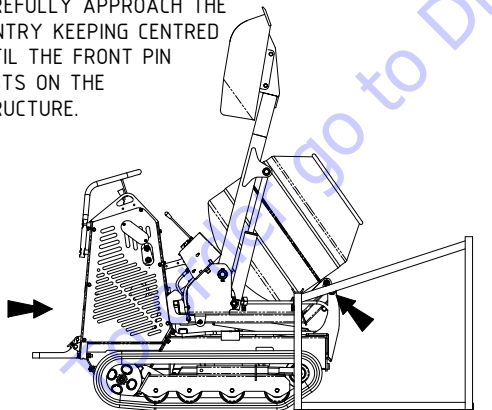

- 6** MOVE FORWARDS SLOWLY LIFTING THE BOOM FRAME AT THE SAME TIME TO TAKE THE PINS ABOVE THE SPECIAL RESTS.

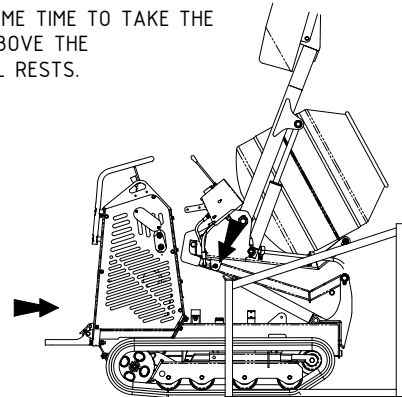

- 7** LOWER THE BOOM FRAME UNTIL THE PINS ARE POSITIONED ON THE SPECIAL RESTS "A".

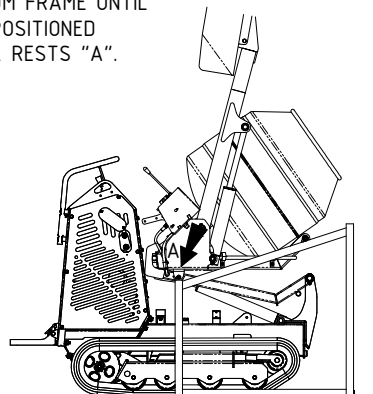

- 8** MOVE BACKWARDS SLOWLY RELEASING THE BOOM FRAME FROM THE ACCESSORY AND THE MINIDUMPER FROM THE GANTRY.

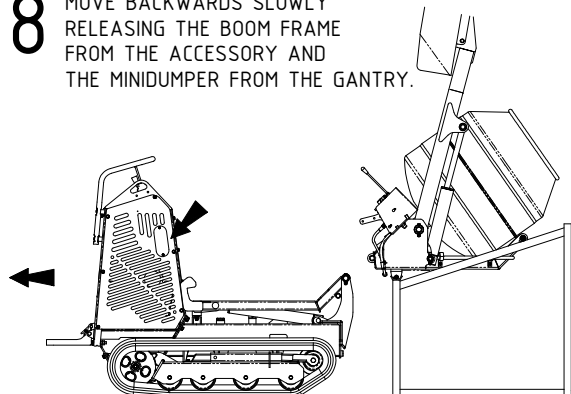

2.8.7 INSTRUCTIONS FOR CONCRETE MIXER KIT LINK-UP BY USING LIFTING JACK

- 1** CAREFULLY APPROACH THE GANTRY KEEPING CENTRED WITH THE STRUCTURE.

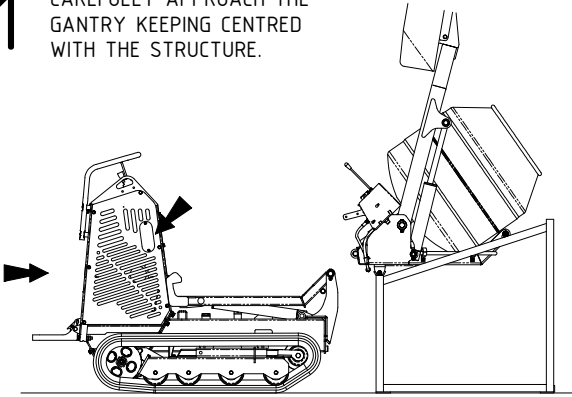

- 2** RAISE THE BOOM FRAME UNTIL COUPLING THE ACCESSORY.

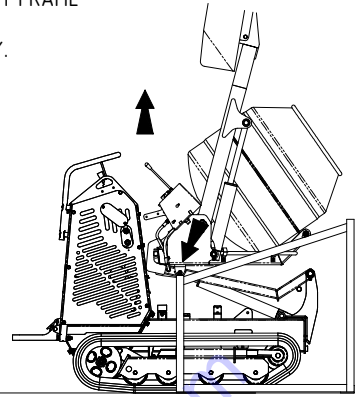

- 3** RAISE THE ACCESSORY TO RELEASE THE RESTING PINS.

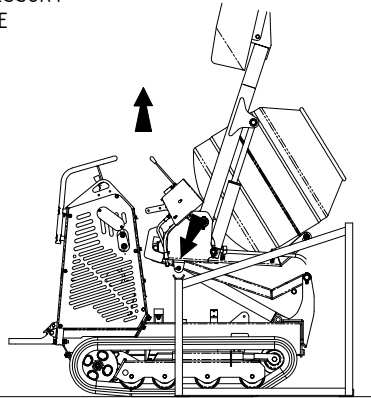

- 4** MOVE BACKWARDS SLOWLY UNTIL THE ACCESSORY RESTS ON THE BOOM FRAME.

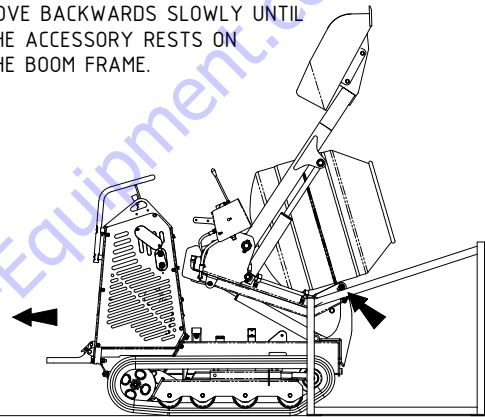

- 5** LOWER THE ACCESSORY COMPLETELY.

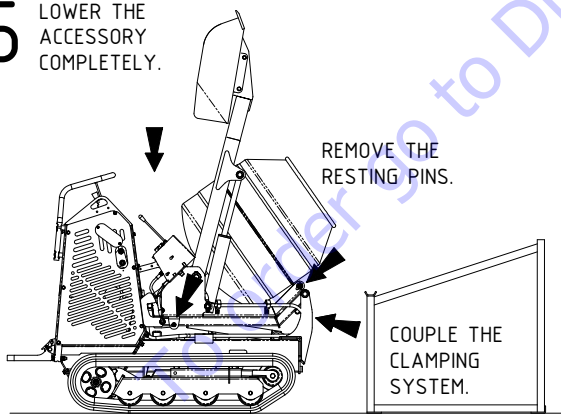

- 6** FIT THE CONTROL PANEL USING THE TWO LOCKING KNOBS "A". CONNECT THE FLUID POWER PIPES THROUGH THE SPECIAL QUICK COUPLINGS.

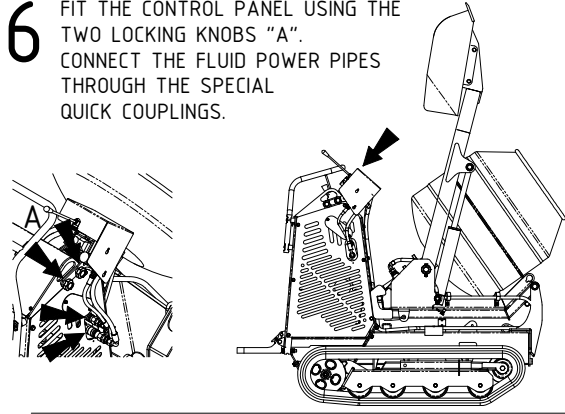

- 7** RAISE THE ACCESSORY AND POSITION THE TWO PIPE STOPPER BRACKETS ON THE MACHINE FRAME.

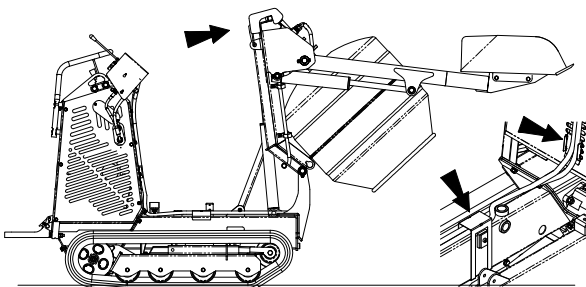

- 8** RELEASE THE BOOM AND LOWER THE ACCESSORY.

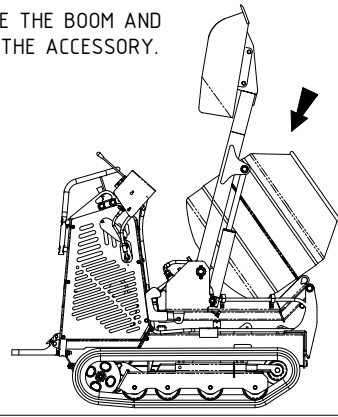

2.8.8 INSTRUCTIONS FOR GRADER BLADE KIT RELEASE

- 1** POSITION THE MACHINE ON SOLID, FLAT TERRAIN AND RAISE THE BLADE TO ITS MAXIMUM HEIGHT WITH LEVER "F" (REF. 2.1). PLACE A BLOCK (AT LEAST 25 CM) UNDER THE BLADE. SLACKEN OFF THE TWO SIDE SAFETY BOLTS SO THAT THEY STAND OUT FROM THE FRAME BY AT LEAST 2 CM.

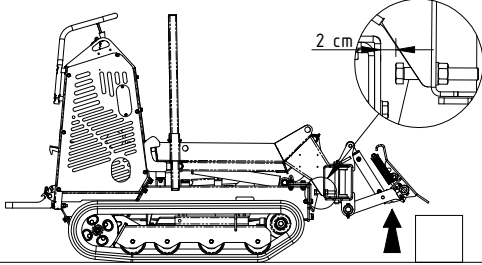

- 2** RELEASE THE TOOL LOCKING SYSTEM AND SLOWLY LOWER THE TOOL ALL THE WAY. THE TOOL WILL DISENGAGE FROM THE TOOL MOUNT.

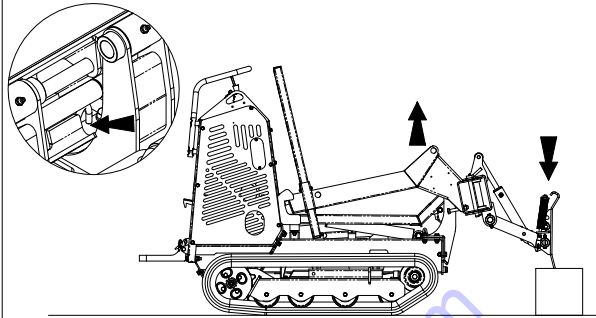

- 3** REMOVE THE PIN SECURING THE COLUMNS SO THAT THEY SLIDE DOWN TO THE GROUND. RAISE THE TOOL MOUNT UNTIL THE COLUMNS CAN BE SECURED AT THEIR TOP HOLES. NOW LOWER THE TOOL MOUNT AGAIN UNTIL THE COLUMNS ARE RESTING AGAINST THE GROUND.

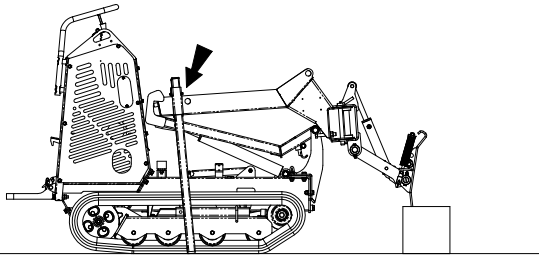

- 4** DISCONNECT THE HYDRAULIC HOSES FROM THE MACHINE WITH THEIR QUICK RELEASE FITTINGS. SLOWLY REVERSE THE MACHINE AWAY FROM THE BLADE UNTIL THE TOOL MOUNT DISENGAGES COMPLETELY FROM THE BLADE.

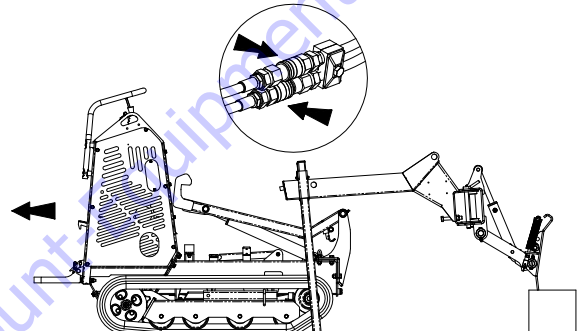

2.8.9 INSTRUCTIONS FOR GRADER BLADE KIT LINK-UP

- 1** DRIVE SLOWLY TOWARDS THE BLADE KIT WHILE MAINTAINING ALIGNMENT WITH THE STRUCTURE. RAISE THE TOOL MOUNT AND MOVE SLOWLY FORWARDS UNTIL IT ENGAGES WITH THE BLADE. TO LIFT THE CONCRETE - MIXER KIT WITH SHOVEL, HOOK THE LIFTING CABLES AT POINTS "A" AND "B".

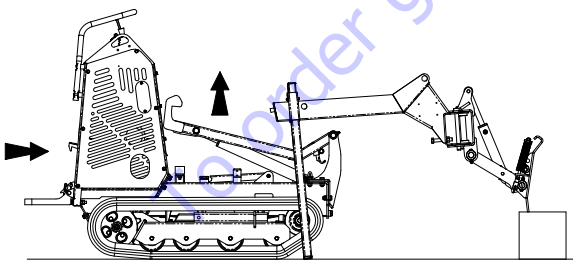

- 2** CONNECT THE HYDRAULIC HOSES TO THE MACHINE WITH THEIR QUICK RELEASE FITTINGS. RAISE THE BLADE UNTIL THE COLUMNS ARE NO LONGER RESTING ON THE GROUND.

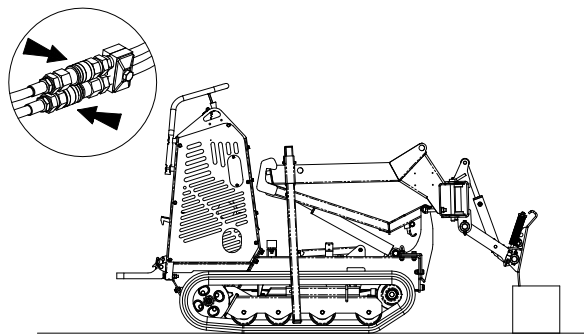

- 3** REMOVE THE PINS LOCKING THE COLUMNS AND SLIDE THEM UP UNTIL THEY CAN BE LOCKED INTO THE RAISED POSITION. USE LEVER "F" (REF. 2.1) TO RAISE THE BLADE UNTIL IT IS RESTING ON THE TOOL MOUNT.

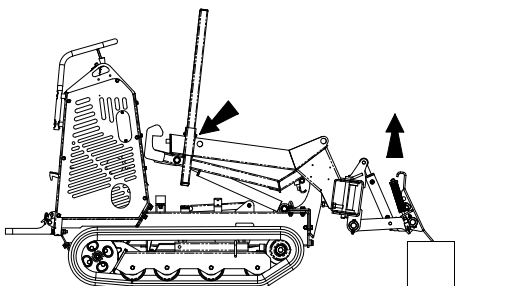

- 4** REMOVE THE PINS LOCKING THE COLUMNS AND SLIDE THEM UP UNTIL THEY CAN BE LOCKED INTO THE RAISED POSITION. USE LEVER "F" (REF. 2.1) TO RAISE THE BLADE UNTIL IT IS RESTING ON THE TOOL MOUNT.

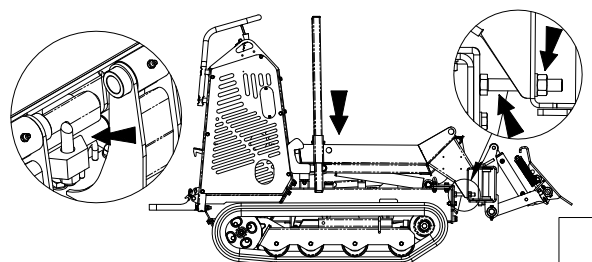

2.9 PRECAUTIONS FOR USING RUBBER TRACK SHOES

RUBBER TRACK SHOE STRUCTURE



WARNING

IF A CRACK IN THE RUBBER REACHES THE STEEL CORD, IT MAY BE RUSTED AND CUT. WHEN ANY CRACK IS DETECTED, REPAIR IT IMMEDIATELY WITH VULCANISER.

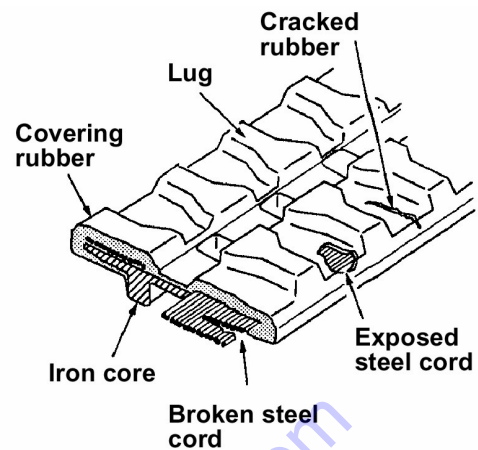

Typical Example

PRECAUTIONS FOR USE

1. Adjust the track tension often.
 - Insufficient tension slips off the rubber track shoe and quickly wears out the sprockets and metal cores.
 - Excessive tension increases travel resistance and this can cause excessive wear at the undercarriage as well as over-extension of the track shoe with possible breakage.
2. To prevent damage to rubber tracks avoid working in the following situations as much as possible:
 - pointed rocks or quarries
 - metal rods or scraps
 - edges or corners of metal or concrete objects
 - fire or other sources of heat
 - travel in contact with concrete paving or walls
3. Immediately wipe off spilt fuel, hydraulic oil or grease from the track shoe surface.
4. Avoid fast turns on the tracks.
5. If the machine is not to be used for a long time (3 months or more) store the tracks avoiding direct sunlight or rain.
6. Owing to the characteristics of the rubber use the machine at a temperature between -25°C and $+55^{\circ}\text{C}$.

2.10 PARKING THE MACHINE.

At the end of the day's work, follow the procedure described below:

PARKING THE MACHINE

Drive the machine to a safe place with a flat surface.

1. Move the accelerator lever forwards to reduce the engine speed
2. Release the travel levers to stop the machine.
3. Lower the loader shovel to the ground applying slight pressure.
4. Switch off the engine.

IN FREEZING CONDITIONS

If freezing temperatures are expected, both crawlers should be cleaned of mud and dirt and the machine parked on wooden planks.

3 MAINTENANCE

3.1 MAINTENANCE INTERVALS

| Check point | Item |
|--|---|
| When required | |
| Tracks | Check and adjust tension |
| Battery | Cleaning and level check of electrolytic liquid |
| Gears with greaser | Grease lubrication |
| Daily (every 8 hours of work) | |
| Engine Oil | Check the oil level |
| Hydraulic oil tank | Check the hydraulic oil level |
| Fuel tank | Check the fuel level |
| Machine checking | General daily check of conditions of machine |
| Every 50 hours of work (Before performing the previous services) | |
| Engine | Clean the air cleaner element |
| Diesel engine | Drain water in the fuel tank |
| Every 200 hours of work (Before performing the previous services) | |
| Engine | Change the oil |
| Engine | Clean the fuel sedimentor |
| Air filter | Change the air cleaner element |
| Hydraulic system | Change the strainer |
| Every 600 hours of work (Before performing the previous services) | |
| Hydraulic oil | Oil change |
| The intervals given depend on the environment in which the machine is used, very dusty environments for example require more frequent cleaning of the air cleaner | |

3.2 RECOMMENDED LUBRICANT TABLE

| Position | Quantity | Specifications |
|---------------------------|---|--|
| HONDA ENGINE GX270 | Max. 1.1 litres | SAE 10W-30 |
| YANMAR ENGINE L100 AE | Max. 1.65 litres | SAE 20W40 |
| HYDRAULIC OIL | Total quantity 22 litres Tank capacity 16 litres | LONG LIFE HYDRAULIC OIL ISO NO. 46 |
| LUBRICATE THE FITTING. | - | Lithium grease EP-2 |

3.3 WHEN REQUIRED MAINTENANCE AND CHECKS

3.3.1 CHECKING THE TRACK TENSION

When the track or tracks rub heavily against the structure that carries the actual track, checking the tension is necessary.

3.3.2 TRACK TENSION ADJUSTMENT

1. Remove the protective cover (A) loosening the M8 screw, wipe off the protective grease, slacken the locknut (B) turning counter-clockwise, tighten the screw (C) until obtaining the required track tension.
2. To even the tension on both sides, move the minidumper forwards and backwards and check the tension again.
3. To complete the operation, tighten the locknut (B), grease, refit the protective cover (A) using the screw.
4. Check again that both tracks are tensioned evenly.

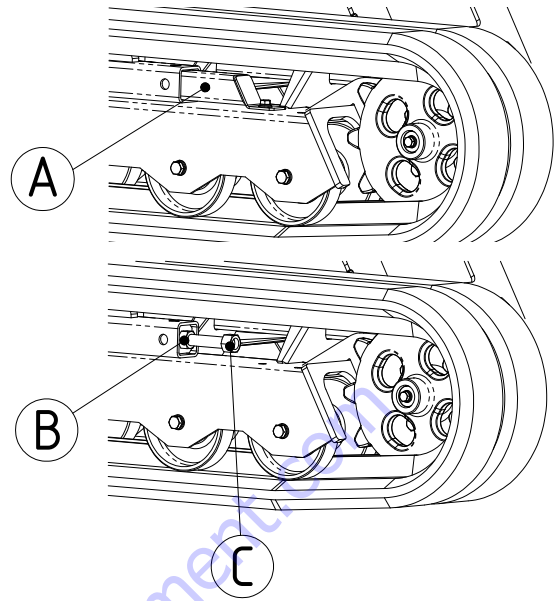

3.3.3 RUBBER TRACK SHOE MAINTENANCE



WARNING

- RUBBER TRACK SHOES MUST BE REPAIRED OR REPLACED AS DESCRIBED BELOW.
- IF IT IS NECESSARY TO REPAIR OR REPLACE A TRACK SHOE CONTACT YOUR DEALER.

1. HEIGHT OF LUGS

Rubber track shoes can be used even if they are worn, however, if excessively worn, they are likely to slip and more engine power is required. If the remaining lug is 5 mm or less, replace it with a brand new one.

2. EXPOSURE OF STEEL CORDS

If the steel cords of a rubber track shoe are exposed due to excessive wear or damage, replace it with a brand new one.

3. BREAKS OF RUBBER TRACK SHOE STEEL CORDS

When a steel cord break is detected, replace the track shoe immediately. If you leave it as it is and continue working, the track shoe might break unexpectedly and could cause serious accidents.

4. CRACKS ON RUBBER COVERING

If a crack is 30 mm or more in length and 8mm or more in depth, repair the rubber immediately. If steel cord shows, even if the crack is smaller, repair immediately. Otherwise, water getting into the crack may rust the steel cords and break the track shoe.

Repair is necessary when cracking depth is 30 mm long or more

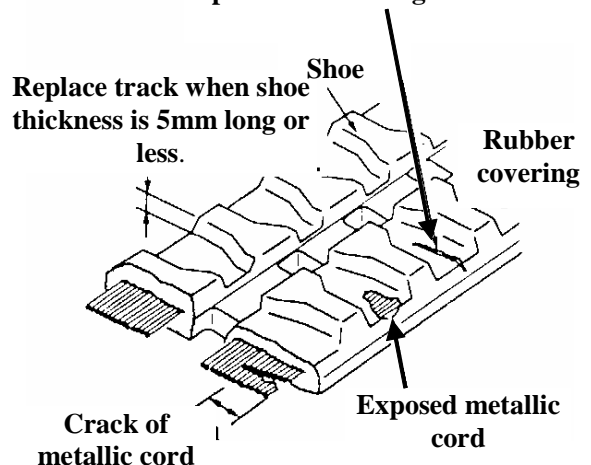

3.3.4 BATTERY MAINTENANCE

**WARNING**

- BATTERY GIVE OFF FLAMMABLE FUMES THAT CAN EXPLODE.
- DO NOT SMOKE WHEN OBSERVING THE BATTERY ELECTROLYTE LEVELS.
- ELECTROLYTE IS AN ACID AND CAN CAUSE PERSONAL INJURY IF IT CONTACTS SKIN OR EYES.
- IF THE ELECTROLYTE COMES IN CONTACT WITH EYES, WASH IT AWAY WITH WATER AND CALL FOR EMERGENCY MEDICAL CURE.
- ALWAYS WEAR PROTECTIVE GLASSES WHEN WORKING WITH BATTERY.

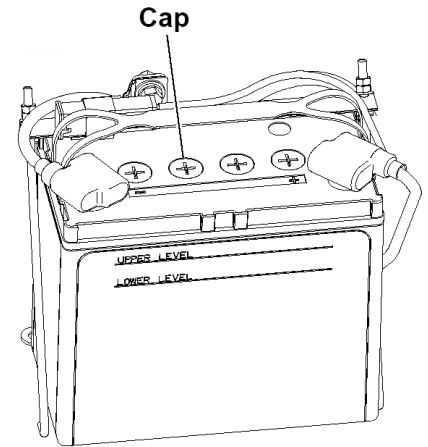

1) Cleanliness

Clean the battery surface. Keep the terminals clean and coated with good quality grease. Install the post cover after coating.

2) Battery recharge

Battery should not be allowed to stand in a fully discharged condition, but should be recharged as soon as possible. If battery is out of use for a long time, it must not be allowed to run down completely. The battery should be given a small recharge, sufficient to bring it back to fully charged state about every one or two months.

Trickle charging is not recommend and during charging as before, care must be taken that temperature of electrolyte does not rise above 40 °C for temperate climates and 52 °C for battery using lower gravity acids specified for tropical use.

3) Checks

Check the fluid level in all the battery elements or check that the level line in the battery is reached. Check the cells once a week in extreme temperatures, battery fluid consumption may be higher.

4) Topping Up

Keep the fluid level immediately below the openings for topping up or, in any case, above the level indicated by the level line, adding water when necessary. If part of the electrolytic fluid has been spilled, replace it with sulphuric acid in the same concentration as that left in the battery.

The fluid level must never fall below the upper edge of the battery plates.

5) Disposal

Dead batteries must be disposed of as required by law.

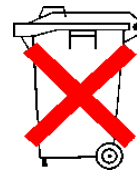

Pb

3.3.5 LUBRIFICATION IN GENERAL

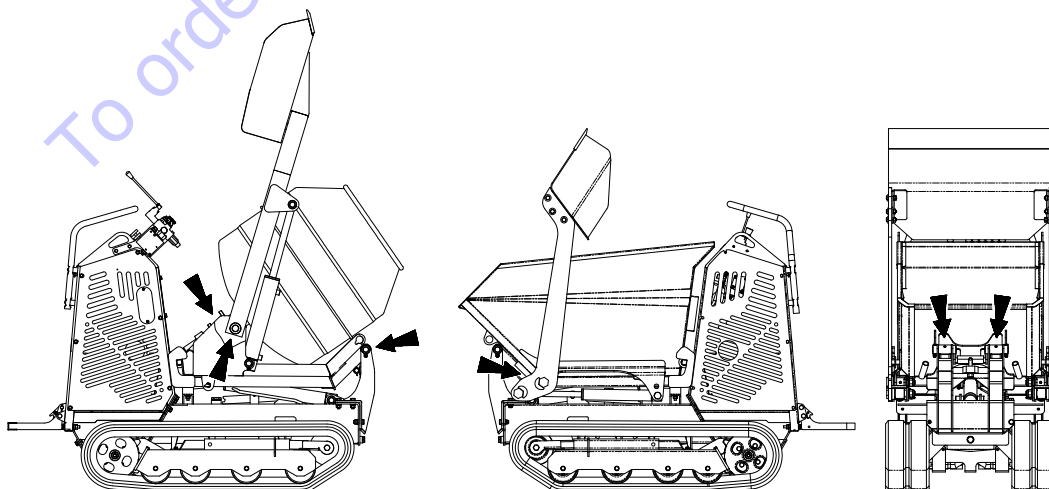

Lubricating the indicated parts when necessary as mentioned in "TABLE OF RECOMMENDED LUBRIFICATION".

3.4 DAILY CHECKS AND MAINTENANCE



DANGER

- CHECK OIL LEVEL WITH THE ENGINE OFF. NEVER CHECK THE OIL LEVEL WITH THE ENGINE RUNNING.
- TO AVOID ENGINE PROBLEMS NEVER EXCEED THE MAXIMUM OIL LEVEL. EXCESS OIL IN THE ENGINE CAN CAUSE SERIOUS DAMAGE TO IT.
- NEVER TURN ON THE ENGINE WHEN THE OIL LEVEL IS ABOVE THE MAXIMUM OR BELOW THE MINIMUM MARK.

3.4.1 ENGINE OIL LEVEL



CAUTION

- HOT OIL AND COMPONENTS CAN CAUSE PERSONAL INJURY. DO NOT ALLOW HOT OIL OR COMPONENTS TO CONTACT SKIN.
- DO NOT OVERFILL THE CRANKCASE TO AVOID ENGINE DAMAGED. ENGINE DAMAGE CAN RESULT.
- NEVER OPERATE THE ENGINE WHEN OIL LEVEL IS ABOVE MAX OR MIN MARKS.

The oil level should be checked at least 15 minutes after stopping the engine. A complete change must be carried out after the first 20 hours of work.. See the special handbook for the instructions involved.

3.4.2 HYDRAULIC OIL TANK LEVEL



CAUTION

- ALWAYS CLEAN THE AREA AROUND THE CAP BEFORE REMOVING IT.
- NEVER EXCEED THE MAXIMUM HYDRAULIC OIL LEVEL IN THE TANK.
- NEVER USE THE MACHINE WHEN THE OIL LEVEL IS ABOVE THE MAXIMUM OR BELOW THE MINIMUM LEVEL.

Place the machine on level ground with the boom pistons and, if present, those of the loader shovel and track extension fully retracted.

1. Check that the oil level on the gauge is in the maximum.
2. If necessary add oil (refer to "HYDRAULIC OIL REPLACEMENT" paragraph of chapter 3 - 7).

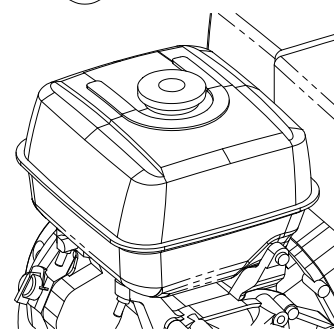
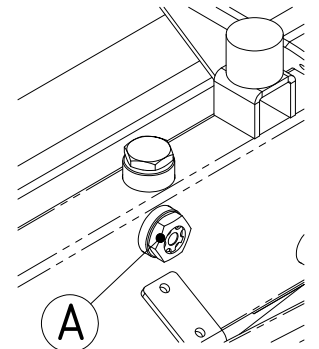

GASOLINE ENGINE

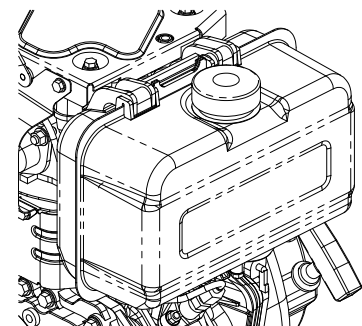

DIESEL ENGINE

3.4.3 FILLING THE FUEL TANK



WARNING

- NEVER REFUEL WITH THE ENGINE RUNNING.
- DO NOT SMOKE DURING REFUELLING OPERATIONS.
- FUEL DISPERSED ON HOT SURFACES CAN CAUSE FIRE.

Refer to the engine instruction handbook.

Always use clean containers for fuels. Use fuels uncontaminated by water, especially in the case of fuel oil. Take care when filling the tank in the rain. To add fuel remove the cap above the tank in the engine compartment and add the necessary fuel using the funnel provided. After filling up make sure that the fuel filler cover is closed properly. Clean any surfaces involved by fuel spilling when filling up.

3.4.4 WALK-AROUND INSPECTION

1. Check the correct tightening of the accessory coupling system.
2. Inspect the loose bolts. Tighten any loose bolts. Repair if necessary.
3. Inspect any cracks in cylinder mounting brackets. Repair if damaged.
4. Inspect attachment cylinders and shovel for damage or excessive wear. Repair if damaged.
5. Inspect the hydraulic system for leaks. Inspect the tank, cylinder rod seals, tubes, plugs, joints and fittings. Correct any leaks.
6. Inspect and repair travel drive leaks. Check oil level if leakage is noticed.
7. Inspect and remove any trash build up in the engine compartment.
8. Accurately clean the accessories (bucket, platform, mixer drum, self-loading shovel, etc.) after use at the end of the day.

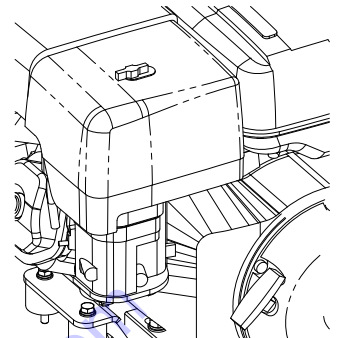

GASOLINE ENGINE

3.5 CHECKS AND MAINTENANCE EVERY 50 HOURS

3.5.1 CLEANING THE AIR FILTERING ELEMENT

CAUTION

- SERVICE THE AIR CLEANER WITH THE ENGINE OFF TO PREVENT ENGINE DAMAGE.
- DO NOT CLEAN THE FILTER ELEMENTS BY BUMPING OR TAPPING THEM. DO NOT USE FILTER ELEMENTS WITH DAMAGED PARTS TO PREVENT ENGINE DAMAGE.
- WHEN USING COMPRESSED AIR FOR CLEANING FILTER ELEMENTS, WEAR PROTECTION FOR THE FACE.

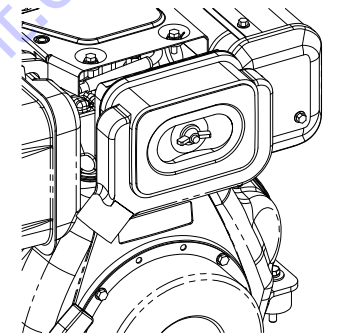

DIESEL ENGINE

Refer to the instructions of the engine handbook for filter element cleaning operations.

Note: A filtering element can normally be cleaned five times. Replace the element when it has been cleaned five times at the most.

3.5.2 FUEL TANK CLEANING AND DRAIN (DIESEL ENGINE)

Refer to the instructions of the engine handbook for engine tank drain and cleaning operations.

Note: always dispose of drained fluids as established by local regulations.

WARNING

FUEL LEAKED OR SPILLED ON TO HOT SURFACES CAN CAUSE A FIRE.

3.6 CHECKS AND MAINTENANCE EVERY 200 HOURS

3.6.1 HYDRAULIC OIL REPLACEMENT

Refer to paragraph of chapter 3.4 and the instructions of the engine handbook for engine oil replacement operations.

Note: always dispose of used oil and filters according to local regulations.

3.6.2 CLEANING THE FUEL SEDIMENTOR (GASOLINE MOTOR)

WARNING

FUEL LEAKED OR SPILLED ON TO HOT SURFACES CAN CAUSE A FIRE.

Refer to the instructions of the engine handbook for cleaning the fuel sediments.

Note: always dispose of drained fluids according to local regulations.

3.6.3 AIR FILTERING ELEMENT REPLACEMENT

Refer to the instructions of the engine handbook for air filtering element replacement operations.

3.6.4 HYDRAULIC SYSTEM STRAINER REPLACEMENT

The strainer is located under cylinder of lifting tool holder.

1. Raise the tool holder and switch off the engine.
 2. Loosen the oil filler cap (1) to relieve the tank pressure.
 3. Clean the area to keep dirt out of the tank and the filter body (2).
 4. Place a suitable container under the strainer to collect any oil coming out during replacement of the strainer cartridge.
- Note:** dispose of used oil and used strainers according to local regulations.
5. Use the special wrench to remove the strainer cartridge (3) turning counter-clockwise. Clean the casing (2).
- Note:** the strainer cartridge must be replaced. It is not possible to re-use an already used cartridge.
6. Moisten the seal ring (4) with oil.
 7. Insert the new cartridge (3), press in place by hand, then use the special wrench to tighten by one turn.
 8. Start the engine and check the hydraulic oil level.
 9. Pressurise the tank again: after fully extending all the pistons with the cap (1) open, close the tank filler cap.
 10. Check that there are no leaks from the cartridge (3).

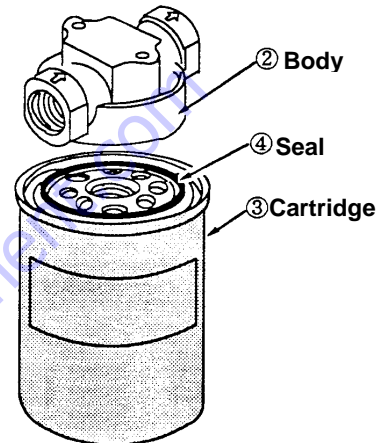
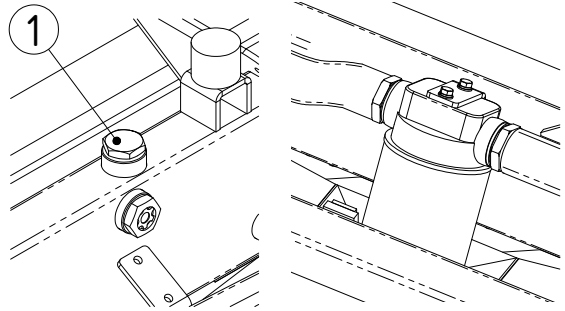

3.7 CHECKS AND MAINTENANCE EVERY 600 HOURS (OR AFTER ONE YEAR)

3.7.1 HYDRAULIC OIL REPLACEMENT

CAUTION

- CONTACT WITH HOT OIL OR PARTS CAN CAUSE BURNS.
- AT OPERATING TEMPERATURE THE OIL TANK IS HOT AND CAN BE UNDER PRESSURE.
- REMOVE THE OIL FILLER CAP (1) SLOWLY TO RELIEVE THE PRESSURE INSIDE THE TANK.
- REMOVE THE OIL FILLER CAP ONLY WITH THE ENGINE OFF AND WHEN IT IS COLD ENOUGH TO DO SO WITH BARE HANDS.

1. Place the machine on level ground with the tool holder pistons and, if present, those of the loader shovel and track extension fully retracted and switch off the engine.
2. Raise the tool holder and engage the lock to prevent accidental lowering and switch off the engine.
3. Clean the area to keep dirt out of the tank.
4. Loosen the oil filler cap (1) to relieve the tank pressure.
5. Remove the drain plug (2) and drain all the oil from the system into a suitable container.

Note: dispose of used oil and used strainers according to local regulations.

6. Clean the inside of the tank using clean oil.
7. Clean and refit the drain plug.
8. Fill the tank with hydraulic oil. (see recommended lubricant table, paragraph 3 – 2).
9. Start the engine and run it for five minutes at idle speed.
10. Operate the control levers to fill the whole hydraulic circuit.
11. Take the machine back to the initial conditions and switch off the engine.
12. Check the hydraulic oil level and top up if necessary to keep the oil level between the two limits on the gauge.
13. Pressurise the hydraulic oil tank. With the tool holder cylinders and loading shovel cylinders fully extended, remove and refit the filler cap (1).
14. Rest the tool holder on the frame, lower the loader shovel to the ground and switch off the engine.

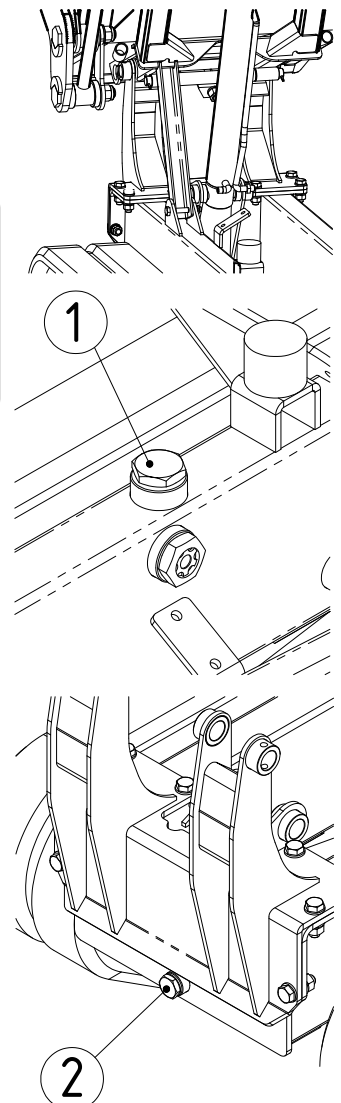

3.8 UNUSUAL OPERATING CONDITIONS

Special problems in maintenance and operation are caused by unusual conditions such as extremes in heat, cold and humidity, high altitude, salt water, and dusty or sandy work sites. When operating under such conditions, special precautions must be taken to prevent machine damage, minimize wear, and avoid component deterioration.

EXTREME COLD

1. Condensation in the fuel tank contaminates the fuel supply with water, which can freeze in the fuel lines and block the fuel flow to the engine. To minimize this possibility, keep the tank as full as is practical during cold weather. This may entail refilling the tank more frequently than usual, but the inconvenience is small compared to clearing a blocked fuel line.
If water should be noticed in the fuel supply, drain the tank and refill it with uncontaminated fuel.
2. Lubricate the machine with the lubricants recommended for cold weather operation in the Lubrication Section. If necessary, change the engine oil and other lubricants in order to conform to the recommendations.
3. The battery is probably the most sensible element to low temperatures. Freezing temperatures of battery electrolyte is as higher as the more discharged battery. When this can occur, be sure that battery is always charged, mainly when you know that the machine has not been working for a long time. Further, battery would discharge also when terminals should be covered by ice or snow, by causing a short-circuit. Keep dried both terminals and clamps. Keep away an eventual beginning of corrosion, by using water and sodium carbonate. In case of a long working stop at very low temperatures, is advisable to remove battery, by keeping it in a sheltered place.



CAUTION

WATER ADDED TO THE BATTERY CAN FREEZE BEFORE IT MIXES WITH THE ELECTROLYTE. DURING VERY COLD WEATHER, ADD WATER TO THE BATTERY JUST PRIOR TO, OR DURING OPERATION OF THE MACHINE. IF THE MACHINE IS NOT TO BE RUN. WATER MAY BE ADDED IF AN EXTERNAL CHARGER IS CONNECTED TO THE BATTERY.

4. Special attention must be given to the hydraulic oil during very cold weather.



WARNING

BEFORE ANY WORKING OPERATION OF THE MACHINE, HEAT UP HYDRAULIC OIL, AS INDICATED IN THE PARAGRAPH 1.1.

5. At the end of the work period, or whenever the machine is to be left idle for extended periods, prevent it from being frozen to the ground by parking it on wood, concrete, asphalt or mat surface.

EXTREME HEAT

Like extreme cold, extreme heat requires that precautions be taken with respect to the battery and lubrication.

1. High temperatures necessitate the use of lubricants which are both more viscous and which resist deterioration at higher operating temperatures. Refer to the Lubrication Section and lubricate the machine using the lubricants recommended for the expected temperatures. Crankcase oil is particularly important because it helps dissipate heat. Check the oil level frequently and add oil as required to maintain required level. Too little oil will hinder heat dissipation.
2. Increased evaporation rates will cause the battery electrolyte level to fall more rapidly during very hot weather. Check the level frequently and add distilled water as required to maintain the proper level.
3. Air circulation around the engine and battery must not be restricted. Keep air intake and exhaust openings clear of leaves, paper or other foreign matter which may restrict air flow.
4. Keep the engine clean of dirt, grease and other substances which inhibit heat dissipation.
5. Avoid prolonged periods at idle and shut the engine down if operations are interrupted.

SANDY OR DUSTY WORK SITES

The presence of large amounts of sand or dust at the work site can contribute to accelerated component wear. Either substance will act as an abrasive when deposited on moving parts of the machine. This problem can be alleviated by increasing the schedule of lubrication and by servicing breathers and fillers at more frequent intervals. Follow the recommendations below when operating in sand or dust on a regular basis.

1. Keep sand and dust out of the hydraulic system by keeping the reservoir filler cap tight and servicing the hydraulic system filters frequently.

2. The fuel system should be kept free of sand and dust by keeping the tank filler cap tight and servicing the fuel filters frequently.
3. The engine breathers and air cleaner should also be serviced frequently to prevent sand and dust from entering the engine. The engine oil and oil filter should be changed at shorter than normal intervals to ensure a clean oil supply to the engine's moving parts.
4. When lubricating the machine, thoroughly clean each grease fitting before attaching the grease gun. Pump generous amounts of grease into all lubrication points, using the fresh grease to pump out old.
5. Adequate ground bearing support may be required for the tracks when operating in soft sand. Be alert for signs of track digging into sand during operations. It may be necessary to back off and fill in area where tracks dig in. The increased frequency of lubrication and service discussed above should be determined by observations made at the work site. Inspection will determine how long it takes for lubricants, breathers and filters to accumulate unacceptable amounts of sand or dust. The frequency of lubrication and service should be adjusted accordingly.

HIGH HUMIDITY OR SALTWATER

In some locations, such as coastal areas, the machine may be exposed to the deteriorating effects of salt, moisture, or both. To protect exposed metallic surfaces, wiring, paint and other items, keep them dry and well lubricated where salt or high humidity are encountered.

1. Make frequent inspections for rust and corrosions and remove them as soon as they are detected. Dry and paint exposed surfaces after rust and corrosion have been removed.
2. Where paint may not be applied, such as on polished or machined surfaces. coat the area with grease or lubricant to repel water.
3. Keep bearings and their surrounding surfaces well lubricated to prevent the entry of water.
4. Never use saltwater in the cooling system. Internal corrosion will occur and all parts will have to be replaced.
5. Hose down the machine periodically when working in saltwater. If necessary, use an oil soaked cloth to clean moving parts.
6. If the machine is submerged, be sure it is never submerged in water deeper than upper crawler belt. If the machine exceeds this limit, disassemble, clean and lubricate the lower.

HIGH ALTITUDES

Variations in altitude alter the fuel-air mixture burned in the engine and affect the engine's performance. At high altitudes. Atmospheric pressures are lower and less oxygen is available for combustion of the fuel. Above 1500 meter, the engine fuel setting may have to be changed to ensure proper performance.

Consult engine manufacturer should this problem answer. Keeping the air cleaner clean and free of obstructions will help alleviate high altitude problems. At high altitudes, closely monitor the engine temperature for overheating.

3.9 LONG TIME STORAGE



WARNING

CARRY OUT THE OPERATIONS FOR LAYING UP THE ENGINE FOLLOWING THE INSTRUCTIONS GIVEN IN THE RELEVANT MANUALS.

IF THE MACHINE IS STORED INDOORS, GOOD VENTILATION IS RECOMMENDED TO PREVENT RUST.

Before long term storage, follow the procedure described below:

- Clean the machine and store indoors. If storage outdoors is necessary, choose a flat place and cover the machine.
- Apply grease on the exposed parts of pistons and cylinders.
- To empty completely the circuit of feeding.
- If the machine is provided of electric starting, open switch – out battery (H).

During storage operate the machine once a month to maintain a film of lubricating oil.

After storage:

- Remove the grease from the cylinder pistons.
- Check the level of the fuel and lubricant tanks.

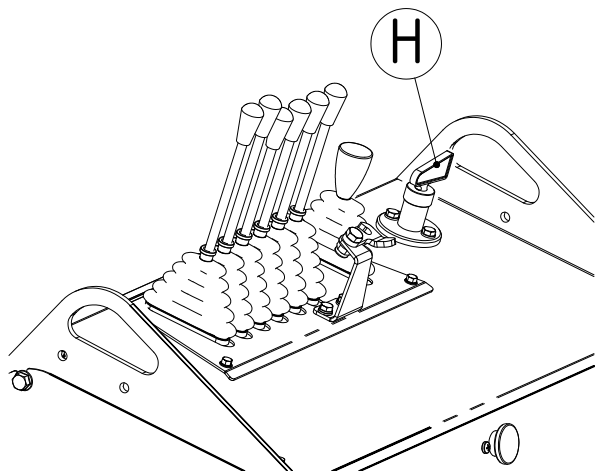

4 TROUBLE SHOOTING

4.1 TROUBLE AND REMEDIES

Note any occurrence unusual in normal machine operation during daily operations.

For every fault detected, try to investigate the causes, and act promptly.

If unusual occurrences are overlooked due to neglect, more serious problems may arise later.

| SYMPTOM | PROBABLE CAUSE | SOLUTION |
|---|--|--|
| Control lever stiff or does not return automatically. | <ul style="list-style-type: none"> Faulty control valve. | <ul style="list-style-type: none"> Ask for service. |
| No operations possible or power failing. | <ul style="list-style-type: none"> Low hydraulic oil. Oil strainer clogged. Engine output drop. Pump or coupling failure. Low adjustment valve pressure. Faulty control valve. | <ul style="list-style-type: none"> Top up to the correct level. Perform oil strainer maintenance. Perform air cleaner maintenance and check supply. Ask for service. Ask for service. Ask for service. |
| The drive is not working on one or both sides. | <ul style="list-style-type: none"> Foreign matter, such as stone has got caught. Engine failing. | <ul style="list-style-type: none"> Remove foreign matter. Ask for service. |
| Straight travel defective. | <ul style="list-style-type: none"> Something trapped. Different track tension. Defective pump. Defective travel levers. Engine or braking valve failure. | <ul style="list-style-type: none"> Remove foreign matter. Adjust tensions on both sides. Ask for service. Ask for service. Ask for service. |
| Bucket lifting power failure. | <ul style="list-style-type: none"> Low hydraulic oil. Low adjustment valve pressure. Damaged control valve. Hydraulic cylinder failure. | <ul style="list-style-type: none"> Top up to the correct level. Ask for service. Ask for service. Ask for service. |

4.2 SPARE PARTS



WARNING

- REPLACE WORN AND DAMAGED PARTS WITH ORIGINAL KATO IMER SPARE PARTS.
- USING NON-ORIGINAL SPARE PARTS CAN CAUSE DAMAGE AND INJURY.
- KATO IMER IS NOT LIABLE FOR DAMAGE CAUSED BY THE USE OF NON-ORIGINAL SPARE PARTS, UNLESS EXPRESSLY AUTHORISED.



WARNING

- IT IS FORBIDDEN TO MAKE CHANGES OF ANY SORT TO THE STRUCTURE AND THE PLANT DESIGN OF THE MACHINE BECAUSE THIS MAY COMPROMISE ITS SAFE USE.

5 HYDRAULIC SYSTEM

5.1 TECHNICAL DATE

| REF. | DESCRIPTION | PRESSURE | |
|------|----------------------------------|----------|---------------------|
| | | Mpa | Kgf/cm ² |
| MR1 | Main pump max. pressure valve P1 | 13,7 | 140 |

Hydraulic oil tank capacity 16 litres
Hydraulic oil system capacity 22 litres
Pump flow rate P1-P2-P3: 3x14 litres/min.

| POWER TAKE-OFF. | Mpa | Kgf/cm ² | Litri/min |
|-----------------|------|---------------------|-----------|
| Pressure MAX | 13,7 | 140 | - |
| Capacity MAX | - | - | 14 |

5.2 HYDRAULIC SYSTEM DIAGRAM 4 ELEMENTS

The 4-element control valve is used:

- In the base version, fixed track, with only loading bucket, dumper or deck with no possibility to install the loader shovel or takeoff for auxiliary equipment for any attachments.

TRIPLE SUCTION OIL PUMP

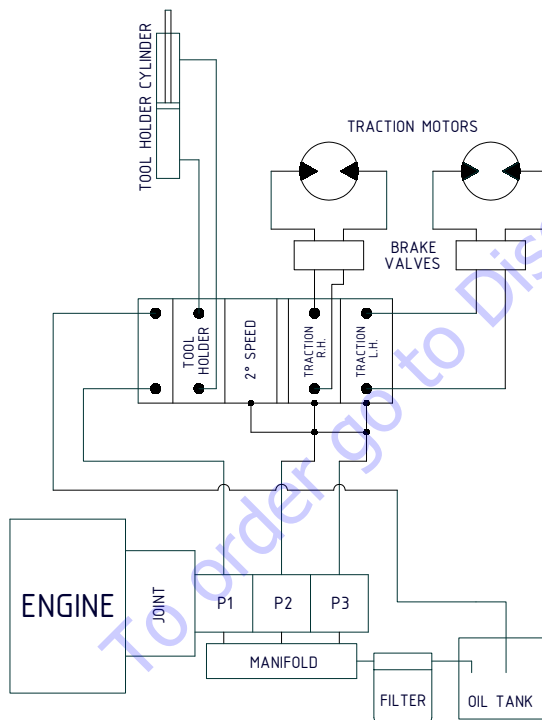

SINGLE SUCTION OIL PUMP

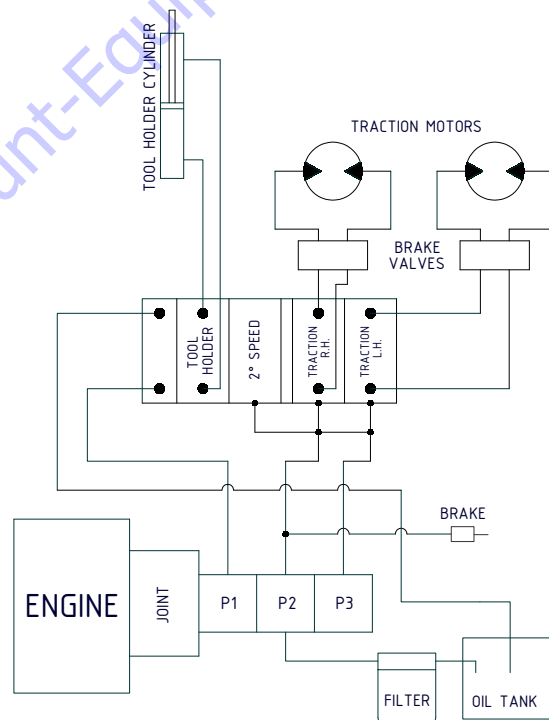

5.3 HYDRAULIC SYSTEM DIAGRAM 5 ELEMENTS

The 5-element control valve is used:

- In the version with fixed track, loading bucket, dumper or deck and with the possibility of installing the loader shovel or another attachment that needs power take-off.

HYDRAULIC SYSTEM DIAGRAM 5 ELEMENTS (STANDARD)

TRIPLE SUCTION OIL PUMP

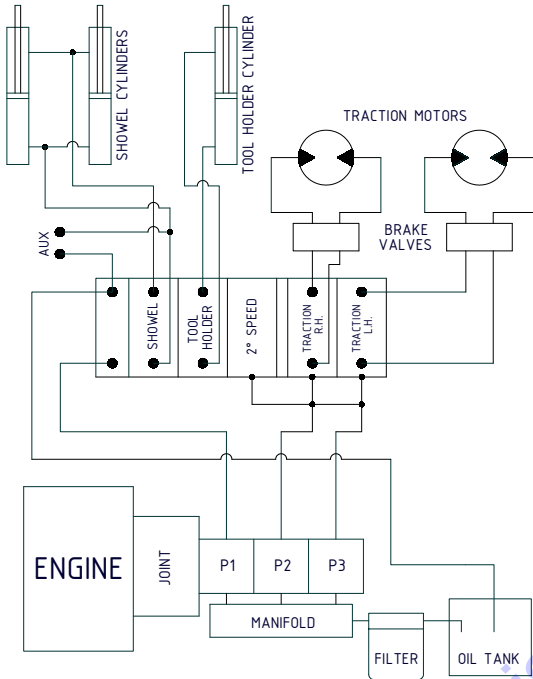

SINGLE SUCTION OIL PUMP

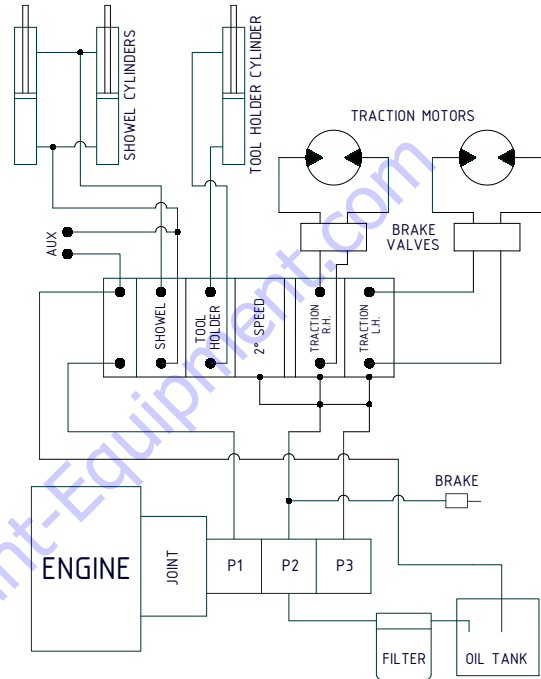

HYDRAULIC SYSTEM DIAGRAM 5 ELEMENTS (HI-FLOW)

TRIPLE SUCTION OIL PUMP

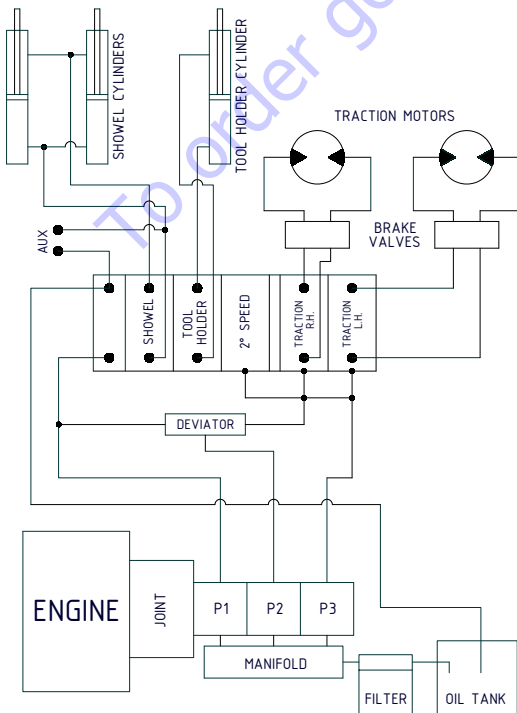

SINGLE SUCTION OIL PUMP

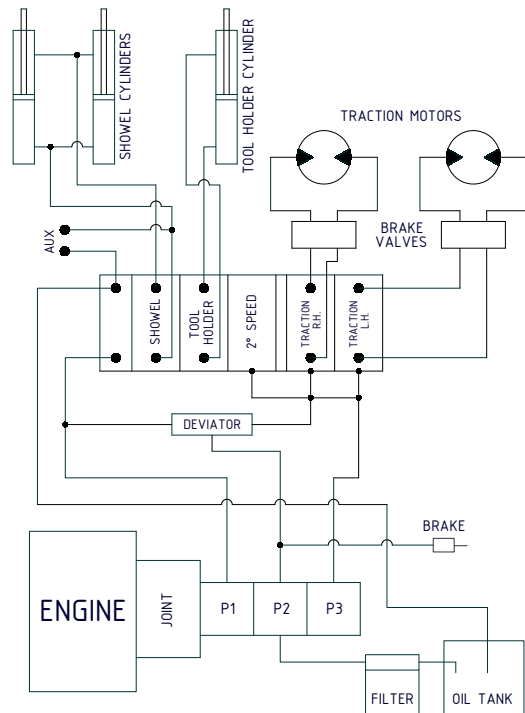

5.4 HYDRAULIC SYSTEM DIAGRAM 6 ELEMENTS

The 6-element control valve is used:

- In the version with extensible track, with loading bucket, dumper or deck and with the possibility of installing the loader shovel or another attachment that needs power takeoff.

HYDRAULIC SYSTEM DIAGRAM 6 ELEMENTS (STANDARD)

TRIPLE SUCTION OIL PUMP

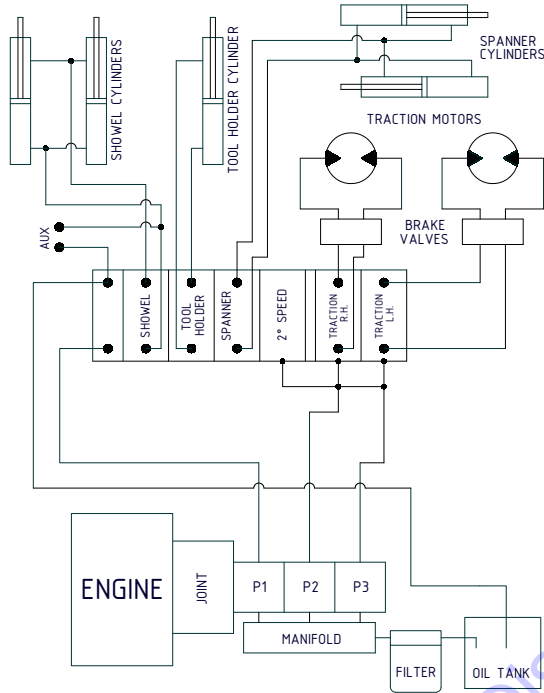

SINGLE SUCTION OIL PUMP

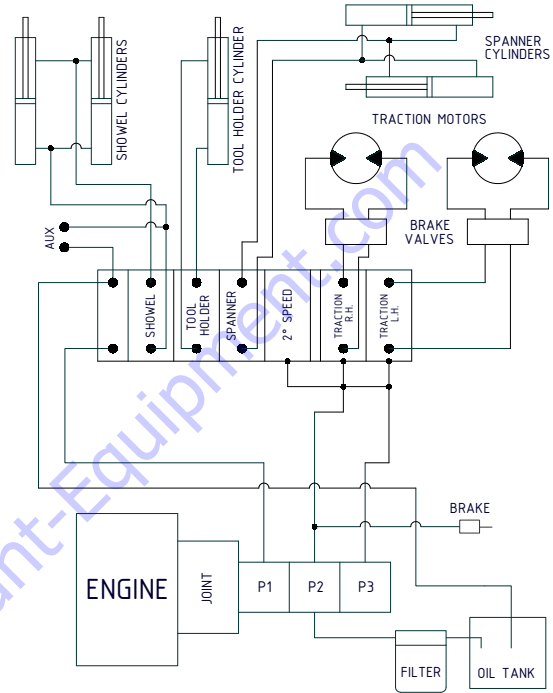

HYDRAULIC SYSTEM DIAGRAM 6 ELEMENTS (HI-FLOW)

TRIPLE SUCTION OIL PUMP

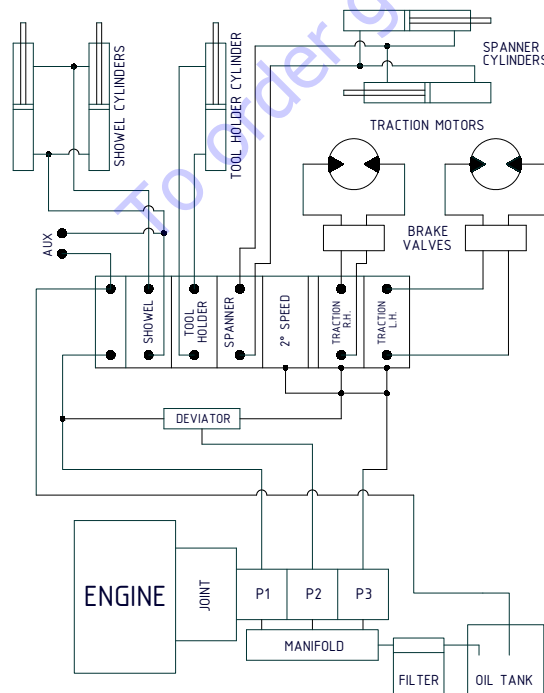

SINGLE SUCTION OIL PUMP

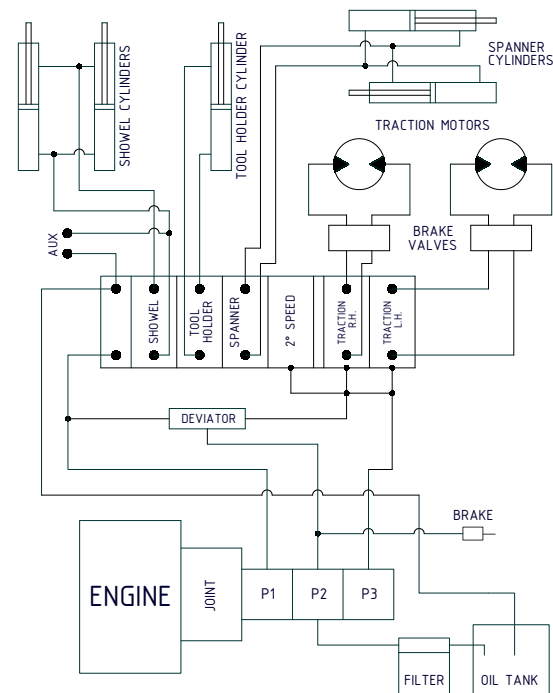

6 TECHNICAL DATA

6.1 GENERAL SPECIFICATIONS

GENERAL MACHINE PERFORMANCE RATES

| | | |
|-----------------------------|-----------|-----------|
| Travel speed | km / h | 2,3-3,2 |
| Gradeability | % (°Deg.) | 36% (20°) |
| Gradeability with load | % (°Deg.) | 20% (11°) |
| Capacity | Kg | 700 |
| Operating temperature range | °C | -20 / +46 |

WEIGHT

| <i>Operative weight</i> | <i>Kg</i> |
|---|-----------|
| With gasoline base plus / extendible | 430 / 480 |
| With gasoline 11HP AE: plus / extendible | 450 / 500 |
| With diesel engine: base plus / extendible | 472 / 522 |
| Bucket / Bucket with shovel | 58 / 128 |
| Platform | 75 |
| Concrete mixer / Concrete mixer with shovel | 120 / 170 |

Operational total weight is determined by weight of base version machine and the weight of used accessory.

ENGINE SYSTEM

| | | | |
|-----------------|---------------------|---------------|---------|
| GASOLINE engine | Honda GX 270 | 6kW / 8HP | 3600rpm |
| GASOLINE engine | Honda GX 390 | 8,2kW / 11HP | 3600rpm |
| DIESEL engine | Yanmar L100 | 7,4kW / 9,9HP | 3600rpm |

NOISE LEVEL FUEL AND DIESEL ENGINES

| | | <i>Benzina</i> | <i>Diesel</i> |
|--|-----|----------------|---------------|
| Guaranteed sound power level | LwA | 100 dB | 108 dB |
| Sound pressure level at the operator's ear | LpA | 83 dB | 88 dB |

6.2 MACHINE DIMENSIONS

DIMENSIONS

| Description | | Rubber track shoes | |
|--|---|--------------------|-------------|
| Track width | | mm | 200 |
| Track length | | mm | 1250 |
| Machine width | Retracted track | mm | 760 |
| | Extended track | mm | 1060 |
| Machine height to controls | | mm | 1320 |
| Slewing radius | | mm | 910 |
| Minimum ground clearance | | mm | 100 |
| Bucket: volume | | m ³ | 0,33 |
| Loading platform (optional) Dimensions: | Closed panels [length x width x height] | mm | 990x790x200 |
| | Open panels [length x width] | mm | 1240x1290 |
| Kit concrete mixer (optional) | Capacity drum / Mixed capacity | lt | 250 - 190 |
| | Drum speed | rpm | 24 - 25 |

6.3 CONCRETE MIXER KIT SPECIFICATIONS

| | | |
|------------------------------|-----------------|---------|
| Mixing drum capacity | Litres | 250 |
| Output capacity | Litres | 190 |
| Optimum drum speed | Rpm | 24 - 25 |
| Hydraulic flow rate required | Litres / minute | 12 - 14 |
| Pressure | bars | 140 |

| | | |
|----------|-----------------------|---------------------------------|
| 6 | SPECIFICATIONS | MINIDUMPER CARRY 107 |
|----------|-----------------------|---------------------------------|

6.4 LEVEL OF EXPOSURE TO VIBRATIONS
(DIRECTIVE 2002/44/CE)

| | Unit | Whole-body | Hand / Arm |
|-----------------------------|--------------------|------------|------------|
| Daily exposure action value | m/sec ² | 0,5 | 2,5 |
| Daily exposure limit value | m/sec ² | 1,15 | 5 |

Equivalent acceleration - For whole-body vibrations

(Method of measurement according to ISO2631)

| GROUND | ACTION | CARGE | UNIT | Eq.Ac. | Eq.Ac. (max.) |
|------------------------------|--|-------|--------------------|--------|---------------|
| Flat and compacted / Asphalt | Forward travel | NO | m/sec ² | 1 | 0,87 |
| | Backward travel | NO | m/sec ² | 0,87 | 0,74 |
| Flat and compacted | Complete cycle { - Loading (Self-load. Shovel), - Unloading, - Forward travel, - Backward travel | YES | m/sec ² | 1,07 | 0,8 |

Equivalent acceleration – For hand-arm vibrations

(Method of measurement according to ISO5349)

| GROUND | ACTION | CARGE | UNIT | Eq.Ac. |
|------------------------------|--|-------|--------------------|--------|
| Flat and compacted / Asphalt | Forward travel | NO | m/sec ² | 3,25 |
| | Backward travel | NO | m/sec ² | 3,68 |
| Flat and compacted | Complete cycle { - Loading (Self-Load. Shovel), - Unloading, - Forward travel, - Backward travel | YES | m/sec ² | 3,42 |

6.5 OVERALL DIMENSIONS

BUCKET + SHOVEL

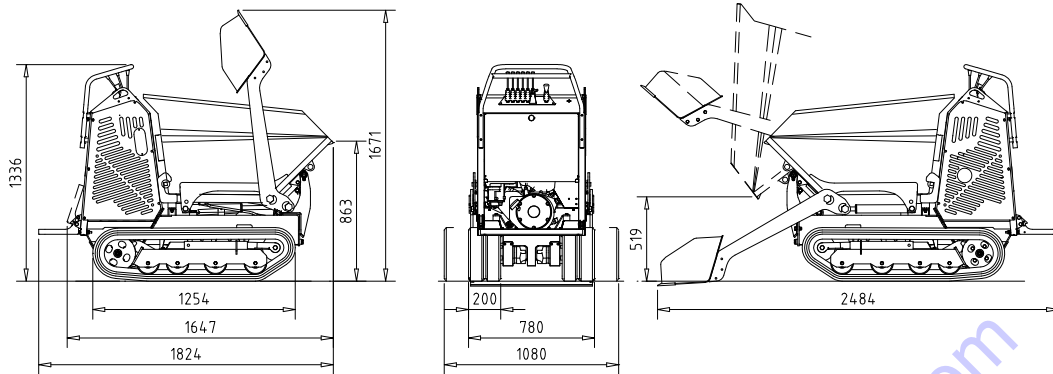

CONCRETE MIXER + SHOVEL

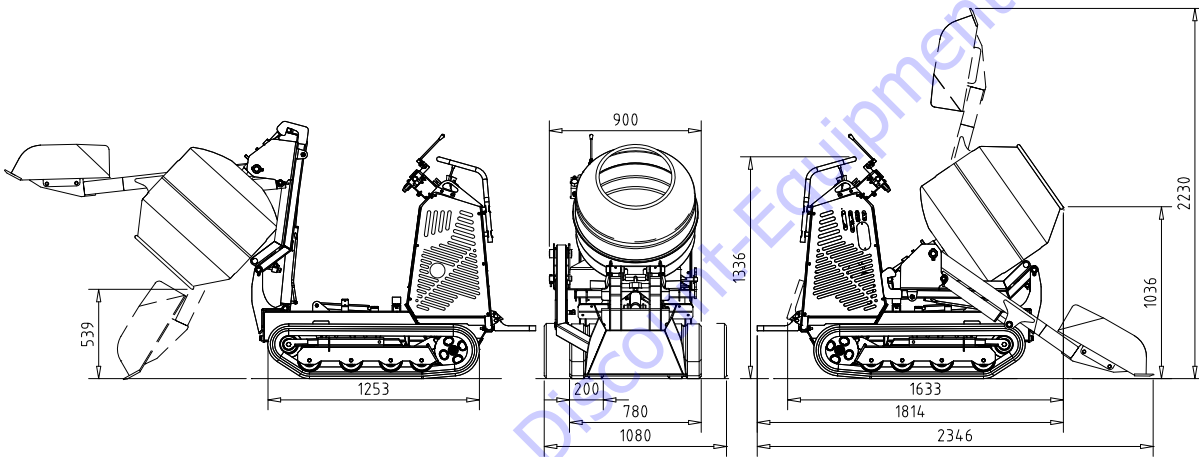

PLATFORM

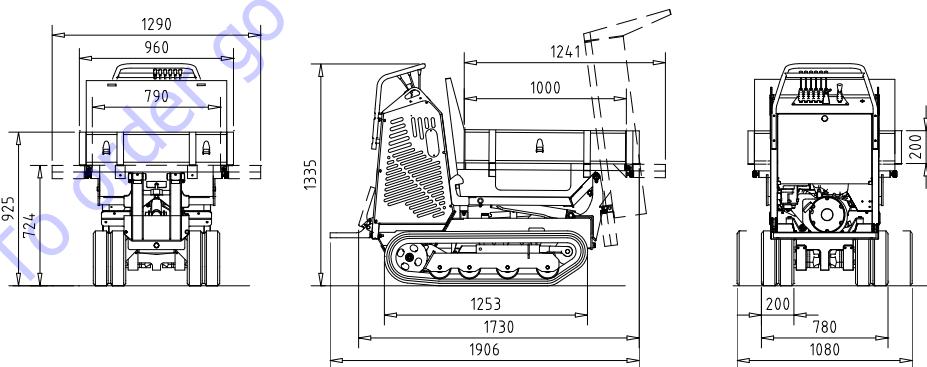

GRADER BLADE

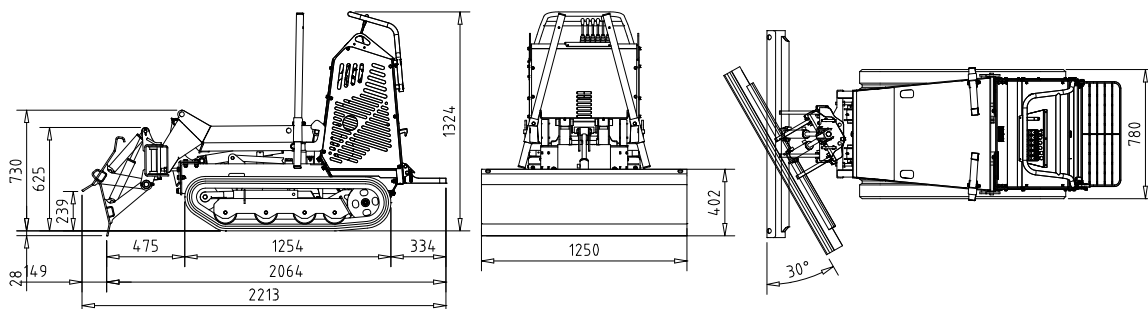

To order go to Discount-Equipment.com

TRACKED MINIDUMPER

CARRY 107

PUBLISHED: MARCH 2017

KATO IMER S.p.A.

ITALY

TO PURCHASE THIS PRODUCT PLEASE CONTACT US



**Equipment Financing and
Extended Warranties Available**



**Discount-Equipment.com is your online resource for
commercial and industrial quality parts and equipment sales.**

561-964-4949

visit us on line @ www.discount-equipment.com

Select an option below to find your Equipment

Search by Manufacturer

Search by Product Type

Request a Quote

We sell worldwide for the brands: Genie, Terex, JLG, MultiQuip, Mikasa, Essick, Whiteman, Mayco, Toro Stone, Diamond Products, Generac Magnum, Airman, Haulotte, Barreto, Power Blanket, Nifty Lift, Atlas Copco, Chicago Pneumatic, Allmand, Miller Curber, Skyjack, Lull, Skytrak, Tsurumi, Husquvarna Target, Stow, Wacker, Sakai, Mi-T-M, Sullair, Basic, Dynapac, MBW, Weber, Bartell, Bennar Newman, Haulotte, Ditch Runner, Menegotti, Morrison, Contec, Buddy, Crown, Edco, Wyco, Bomag, Laymor, EZ Trench, Bil-Jax, F.S. Curtis, Gehl Pavers, Heli, Honda, ICS/PowerGrit, IHI, Partner, Imer, Clipper, MMD, Koshin, Rice, CH&E, General Equipment, Amida, Coleman, NAC, Gradall, Square Shooter, Kent, Stanley, Tamco, Toku, Hatz, Kohler, Robin, Wisconsin, Northrock, Oztec, Toker TK, Rol-Air, APT, Wylie, Ingersoll Rand / Doosan, Innovatech, Con X, Ammann, Mecalac, Makinex, Smith Surface Prep, Small Line, Wanco, Yanmar

To order go to Discount-Equipment.com

KATO IMER



www.Discount-Equipment.com