



www.Discount-Equipment.com



EN

OPERATING INSTRUCTIONS

TRACKED MINIDUMPER **CARRY 105**

serial numbers from nr.:

MB*00010

(Original instructions)

To order go to Discount-Equipment.com

03/17 – R00

Codice 2050407033



TO PURCHASE THIS PRODUCT PLEASE CONTACT US



**Equipment Financing and
Extended Warranties Available**



**Discount-Equipment.com is your online resource for
commercial and industrial quality parts and equipment sales.**

561-964-4949

visit us on line @ www.discount-equipment.com

Select an option below to find your Equipment

Search by Manufacturer

Search by Product Type

Request a Quote

We sell worldwide for the brands: Genie, Terex, JLG, MultiQuip, Mikasa, Essick, Whiteman, Mayco, Toro Stone, Diamond Products, Generac Magnum, Airman, Haulotte, Barreto, Power Blanket, Nifty Lift, Atlas Copco, Chicago Pneumatic, Allmand, Miller Curber, Skyjack, Lull, Skytrak, Tsurumi, Husquvarna Target, Stow, Wacker, Sakai, Mi-T-M, Sullair, Basic, Dynapac, MBW, Weber, Bartell, Bennar Newman, Haulotte, Ditch Runner, Menegotti, Morrison, Contec, Buddy, Crown, Edco, Wyco, Bomag, Laymor, EZ Trench, Bil-Jax, F.S. Curtis, Gehl Pavers, Heli, Honda, ICS/PowerGrit, IHI, Partner, Imer, Clipper, MMD, Koshin, Rice, CH&E, General Equipment, Amida, Coleman, NAC, Gradall, Square Shooter, Kent, Stanley, Tamco, Toku, Hatz, Kohler, Robin, Wisconsin, Northrock, Oztec, Toker TK, Rol-Air, APT, Wylie, Ingersoll Rand / Doosan, Innovatech, Con X, Ammann, Mecalac, Makinex, Smith Surface Prep, Small Line, Wanco, Yanmar

CONTENTS

ROUTINE MAINTENANCE

PREFACE

SAFETY INFORMATION

1	SAFETY MEASURES	1
1.1	GENERAL	1
1.2	USE OF THE MACHINE	2
1.3	DRIVING SAFETY	3
1.4	LOADING AND TRANSPORT	3
1.5	PARKING	3
1.6	SERVICE	4
1.7	SAFETY LABELS AND SIGNS	5
2	OPERATING INSTRUCTIONS	6
2.1	CONTROLS	6
2.1.1a	DRIVING THE MACHINE (<i>Lever B and C machine with double pump</i>)	7
2.1.1b	DRIVING THE MACHINE (<i>Lever A and B machine with triple pump</i>)	8
2.1.2a	ACCESSORY LEVER (<i>Lever A machine with double pump</i>)	9
2.1.3a	BUCKET LEVER (OPTIONAL) (<i>Lever D machine with double pump</i>)	9
2.1.4a	PARKING BRAKE LEVER (<i>Lever E machine with double pump</i>)	9
2.1.2b	ACCESSORY LEVER (<i>Lever C machine with triple pump</i>)	10
2.1.3b	BUCKET LEVER (OPTIONAL) (<i>Lever D machine with triple pump</i>)	10
2.1.4b	PARKING BRAKE LEVER (<i>Lever E machine with triple pump</i>)	10
2.2	USING THE COMBUSTION ENGINE	11
2.2.1	STARTING THE PETROL ENGINE	11
2.2.2	STOPPING THE PETROL ENGINE	11
2.3	PREHEATING THE MACHINE	11
2.4	LIFTING THE MACHINE	12
2.5	LOADING AND UNLOADING THE MACHINE	12
2.6	EQUIPMENT	13
2.7	OPERATION AND ACCESSORIES	14
2.7.1	SKIP	14
2.7.2	SELF-LOADING BUCKET	14
2.7.3	LOADING PLATFORM	14
2.7.4	FOOT PLATE (OPTIONAL)	15
2.7.5	ASSEMBLING THE SELF-LOADING BUCKET (OPTIONAL)	15
2.7.6	PARKING BRAKE	17
2.8	ACCESSORY REPLACEMENT PROCEDURE	18
2.8.1	DISENGAGING AND REMOVING ACCESSORIES	18
2.8.2	LIFTING THE SKIP WITH SELF-LOADING BUCKET	20
2.9	PRECAUTIONS WHEN USING RUBBER TRACKS	21
2.10	PARKING THE MACHINE	21
3	MAINTENANCE	22
3.1	MAINTENANCE PERIODS	22
3.2	RECOMMENDED LUBRICANTS TABLE	22
3.3	CHECKS AND MAINTENANCE WHEN NECESSARY	23
3.3.1	CHECK TRACK TENSION	23
3.3.2	ADJUSTING THE TRACK TENSION	23
3.3.3	SERVICING RUBBER TRACKS	23
3.4	DAILY CHECKS AND MAINTENANCE	24
3.4.1	ENGINE OIL LEVEL AND CHANGE	24
3.4.2	HYDRAULIC FLUID RESERVOIR LEVEL	24
3.4.3	FILLING THE FUEL TANK	24
3.4.4	INSPECTING THE MACHINE	25
3.5	CHECKS AND MAINTENANCE EVERY 50 HOURS	25
3.5.1	CLEANING THE AIR FILTER ELEMENT	25
3.6	CHECKS AND MAINTENANCE EVERY 200 HOURS	25
3.6.1	CHANGING THE ENGINE OIL	25
3.6.2	CLEANING THE FUEL SEDIMENT SUMP	25

3.6.3 REPLACING THE AIR FILTER ELEMENT	26
3.6.4 REPLACING THE HYDRAULIC CIRCUIT FILTER	26
3.7 CHECKS AND MAINTENANCE EVERY 600 HOURS (1 YEAR).....	26
3.7.1 CHANGING THE HYDRAULIC FLUID	26
3.8 SPECIAL CONDITIONS	27
3.9 LENGTHY STORAGE	28
4 TROUBLESHOOTING	29
4.1 PROBLEMS AND SOLUTIONS	29
4.2 SPARE PARTS.....	29
5 HYDRAULIC CIRCUIT DIAGRAM	30
5.1 TECHNICAL DATA.....	30
5.2 HYDRAULIC CIRCUIT DIAGRAM	30
6 TECHNICAL SPECIFICATIONS	31
6.1 GENERAL SPECIFICATIONS.....	31
6.2 DIMENSIONS OF MACHINE.....	31
6.3 MACHINE DIMENSIONS AND OPERATING LIMITS.....	32

To order go to Discount-Equipment.com

ROUTINE MAINTENANCE

Proper maintenance is essential to a long and effective service life. KATO IMER has set out a series of controls and jobs to be done at our authorized service centers.

CAUTION: Programmed service is required by the Manufacturer. Failure to have the machine serviced as prescribed voids the warranty.

PROGRAMMED SERVICE PERIODS

JOB \ HOURS	HOURS									
	20/50	200	400	600	800	1000	1200	1400	1600	
Change oil and engine filter	●	●	●	●	●	●	●	●	●	●
Control / replace engine air filter	●	●	●	●	●	●	●	●	●	●
Control / adjust track tension	●	●	●	●	●	●	●	●	●	●
Replace hydraulic circuit filter		●	●	●	●	●	●	●	●	●
Change hydraulic fluid				●			●			

To order go to Discount-Equipment.com

PREFACE

This manual provides all the procedures and instructions required for operating, inspecting and servicing the minidumper. The procedures are designed to provide the best possible performance, productivity and safety. Please note the following rules:

- The manual must be kept on board the machine in the provided compartment.
- Before operating the machine, read this manual throughout.
- Experience will augment the prescriptions of this manual, and will be gained in supervised operation of the machine.

Some of the illustrations given in the manual may not be identical with your machine due to intervening technological developments. If you have any questions about your machine or this manual, please contact your reseller for the most recent updates.

SAFETY INFORMATION

This manual is a practical safe guide to the safe operation and control of the machine. Before operating the machine, read the manual in full. This is the best way to avoid accidents. Incorrect operation, control or servicing of the machine may cause injury or death.

Precautions are highlighted in the manual and on the machine itself with the symbol  and classified with the words **DANGER - WARNING - CAUTION**, depending on the degree of hazard. The classification is as follows:



A dangerous situation which may cause injury or death.



A potentially dangerous situation which may cause injury or death.



A potentially dangerous situation which may cause light or moderate injury. May also be used to indicate the potential for damage to the machine or its parts.

We have made every effort to reduce the risks associated with correct use of the machine and, nonetheless, we cannot be held responsible for predicting every kind of danger in all unintended operating conditions.

We have taken every effort to prevent accidents during the machine's operation, however we are not liable for all hazards in all working conditions.

The owner or operator must **ALWAYS** take care during work and have read and understood this manual sufficiently to have the basic knowledge required to operate the machine correctly.



- **BEFORE OPERATING, INSPECTING OR SERVICING THE MACHINE, READ THIS MANUAL AND MAKE SURE YOU HAVE UNDERSTOOD ITS CONTENTS.**
- **INCORRECT OPERATION OR SERVICING MAY CAUSE ACCIDENTS, INJURY OR DEATH.**
- **KEEP THIS MANUAL AT HAND FOR REFERENCE AT ALL TIMES.**
- **IF LOST OR DAMAGED, ASK YOUR RESELLER FOR ANOTHER COPY.**
- **CONSTRUCTION EQUIPMENT IS COVERED BY A VARIETY OF FEDERAL, NATIONAL AND LOCAL LEGISLATION. SINCE THIS LEGISLATION IS CONTINUALLY CHANGING AND DIFFERS FROM COUNTRY TO COUNTRY, WE CANNOT INCLUDE IT IN THIS MANUAL. THE OWNER OR OPERATOR ARE RESPONSIBLE FOR INFORMING THEMSELVES IN THIS REGARD.**
- **THE MACHINE'S COMPONENTS AND SPECIFICATIONS ARE SUBJECT TO CHANGE WITHOUT NOTICE.**
- **MAKE SURE THAT THE SUPPLIED OPERATING MANUAL CORRESPONDS TO THE FEATURES OF THE MACHINE, IN CASE OF DOUBT CONTACT KATO IMER ASSISTANCE SERVICE.**
- **KATO IMER RESERVES THE RIGHT TO CHANGE THE FEATURES OF THE MACHINE AND/OR THE CONTENTS OF THIS MANUAL, WITHOUT BEING REQUIRED TO UPDATE THE PREVIOUS MACHINE AND/OR MANUALS.**

1 SAFETY MEASURES

1.1 GENERAL



BEFORE USING THE MACHINE MOVE AWAY EVERYONE NEARBY.

1. MAKE SURE YOU HAVE READ AND UNDERSTOOD THE INSTRUCTIONS AND WARNINGS

This manual, the nameplates and labels on the machine provide the information required for correct and safe operation of the machine. The user is responsible for reading and understanding the said information; failure to do so may lead to serious injury. Do not leave anything you have failed to understand to chance. Your reseller will provide any additional information you may require. If you lose or damage the manual, nameplates or labels, your reseller will replace them.

2. CHECK THE MINIDUMPER

Before starting work, check the minidumper and make sure there are no persons or obstacles in your work area. Before starting, carefully check the machine for signs of wear and defects.

3. HEALTH

Take special care of your mental and physical health and note that the operator of a complicated machine should be **PHYSICALLY FIT**. **NEVER** operate the machine under the influence of alcohol, medicines or drugs of any kind.

4. SNUG FITTING WORK CLOTHES

Your work clothing must be snug, without loose sleeves, rings or other jewelry, as they may become trapped in moving parts. Always wear the necessary clothes and accessories, including: helmet, safety gloves, visible clothing, safety boots and ear defenders.

5. BEFORE STARTING THE MACHINE

Since all equipment is hydraulically operated, it is **EXTREMELY IMPORTANT** that the hydraulic fluid be at temperature **BEFORE** you start working. While the fluid is heating up, the operator should check the machine's operation and whether it needs servicing. Remember; the basic principle of hydraulics is flow of hydraulic fluid. If you hear a loud noise, this means that the pump is insufficiently lubricated due to cavitation, often caused by the use of too heavy or dense oil. **NEVER OPERATE THE MACHINE** in such conditions; it can seriously damage the pump.

6. MOVING PARTS

DO NOT approach moving parts. Do not hold anything close to moving parts. This may cause serious accidents.

7. TAKE CARE IN THE VICINITY OF THE MACHINE'S HOT PARTS

Keep the engine away from buildings and other equipment during operation. Keep flammable materials away and not place anything on the engine while it is running.

DO NOT touch the engine or exhaust when the machine is running or before it has had time to cool down. These parts are very hot and cause serious burns.

8. GETTING ON AND OFF THE MACHINE

When getting on and off the machine, **ALWAYS** grip the handles.

NEVER grip the control levers when getting on or off the machine.

NEVER get on or off the machine while it is in motion.

Never attempt to get onto the machine with your hands full.

9. MAINTAIN GOOD VENTILATION

Do not use the machine for indoor works. Take all precautions to vent exhaust gas externally before starting the engine if working in a hole in the ground, tunnel or trench. In such a place, the air tends to stagnate. Breathing exhaust gas is very dangerous. Note that exhaust gases are fatally poisonous.

10. LIGHTING

The machine is designed to work in building jobsites and it does not have own lighting. It must be used in enough illuminated places.

1.2 USE OF THE MACHINE**1. EXECUTE EACH MANOEUVRE, WITH RESPECT OF SAFETY**

Execute all manoeuvres carefully. Operating brusquely the machine this can cause damages and reduce consistently efficiency. Take care of regulations that warrant safety on job site. Leave after a sufficient safety distance between machine and obstacle. Leading the machine on foot raise the platform assuring the hook.

2. DO NOT OVERLOAD

Never overload any cylinder enough to trigger the opening of the safety valve. This would cause an excessive rise in the oil temperature, lowering the useful life of the hydraulic components.

3. SECURE FOOTING FOR SAFE OPERATION

Check that the machine footing is level and firm to avoid skidding or overturning if you need to use the machine on the shoulder of a road or a slope.

4. MACHINE OPERATING LIMITS

The machine should be operated on a flat surface, but if you are moving material on sloping ground, be sure that the tracks are positioned in the direction of the slope and not crossways. If you need to work on soft, rough or unlevelled ground, take care to avoid overturning.

5. TIPPING

Be careful, during the reversal of accessory the center of gravity of the machine can moves, so the operation must be done on a stable and not yielding surface.

1.3 DRIVING SAFETY

1. WORKING MANEUVERS

In normal conditions (not emergency) **ALWAYS** steer as slowly as possible. Steering jerkily or while stationary reduces the service life of the machine and its tracks. Steer slowly so as not to overload the drive wheels, especially on uneven or sloping ground.

2. MOVING THE MACHINE IN SPECIAL CONDITIONS

If the ground is very uneven or rocky, drive the machine very slowly. **NEVER CAUSE IMPACTS** on the machine or its tracks.

3. TAKE CARE WHEN DRIVING ON SLOPES

When operating the machine on sloping ground, drive uphill in reverse, and operate the machine from the ground. Even slight roughness can cause the machine to bump around or tip over

DRIVE IN REVERSE, THE OPERATOR MUST BE UPHILL OF THE LOAD AT ALL TIMES.



CAUTION

MAX. CLIMBABLE GRADIENT 20° - 36%



CAUTION

MAX. CLIMBABLE GRADIENT WITH MAXIMUM LOAD 11° - 20%

NEVER STEER on sloping or unstable ground; the machine may tip over.

NEVER DRIVE ACROSS A SLOPE. When working on sloping ground, always drive uphill or downhill. Take great care on icy ground as the machine may skid.

1.4 LOADING AND TRANSPORT

1. PRECAUTIONS WHEN LOADING/UNLOADING THE MINIDUMPER

ALWAYS load and unload the dumper on flat ground.

ALWAYS use sufficiently thick, wide and long ramps.

Remove any ice, snow or friable material from the ramps and truck bed before loading the machine.

NEVER steer on ramps.

2. TRANSPORT

Secure the machine to the truck with steel ropes and other locking equipment.

1.5 PARKING



WARNING

IF PARKED ON SLOPING GROUND OR WHEN THE MACHINE IS OUT OF SERVICE, ALWAYS ENGAGE THE PARKING BRAKE.

IF THE MACHINE IS TO BE PARKED FOR A LONG TIME ON VERY SLOPING GROUND, CHOCK THE WHEELS WITH ADDITIONAL CHOCKS.

1. PARKING ON EMBANKMENTS AND SLOPES

NEVER LEAVE THE MACHINE PARKED on or near to an embankment, or on the edge of a dig or quarry. They may collapse under its weight. Move the machine away from such danger areas if it is to remain inactive for any time. If possible, park it on flat ground.

2. PARKING ON THE ROAD

If the machine must be parked on the road, warn other road users of its presence with barriers, flags, illuminated notices and signs.

3. LEAVING THE MACHINE UNSUPERVISED

Before leaving the machine unsupervised, **ALWAYS** switch off the engine. Make sure its chocks are placed and the parking brake engaged.

1.6 SERVICE

1. ROUTINE MAINTENANCE

Maintenance may be risky if not done with appropriate caution. Maintenance staff must be aware of the risks and implement suitable safety procedures. Before servicing or repairing the machine, always refer to the instruction manual. Before **ANY** service work, stop the engine and engage the parking brake to prevent unexpected movements which may cause injury, raise the accessory and fit its safety lock.

NEVER ALLOW ANYONE to work on the undercarriage with the accessory raised if it is not securely locked.

During maintenance operations, mark the control levers with labels. These labels can only be removed by aware personnel able to ensure that safety rules are fully observed.

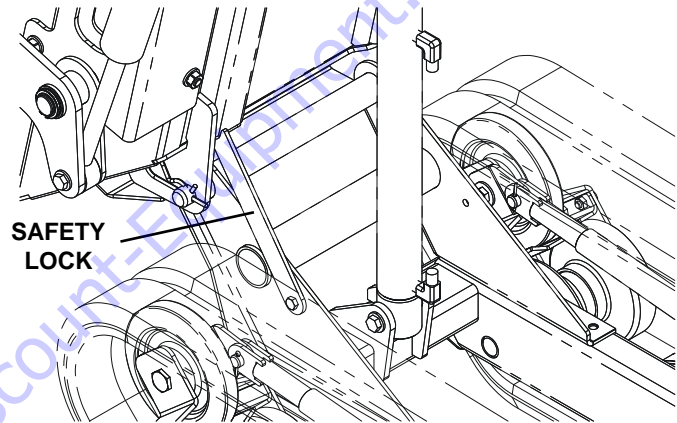

2. CLEANING THE MACHINE

Keep the machine clean. Remove all dirt and grease, and check the machine's equipment. Never leave flammable materials in the machine's work area.

3. ADJUSTING THE HYDRAULIC PRESSURE

The hydraulic pressure must be measured and adjusted by qualified staff using suitable equipment. If such staff is not available, contact your reseller.

4. FIRE AND EXPLOSION

Always keep petrol, lubricants and coolants as far away as possible from sources of heat and ignition. Many liquids are extremely flammable. Dry immediately eventual overflows.

NEVER FILL THE FUEL TANK or lubricate the machine with the engine running.

NEVER SMOKE while filling the fuel tank or in the vicinity of flammable materials.

5. HYDRAULIC PLANT SERVICE

Before disconnecting a hydraulic line, make sure that:

- the engine is off;
- the bucket, if present, is resting on the ground;
- the accessory is raised with its safety lock engaged;
- all pressurized air has been discharged from the hydraulic reservoir (open the filler cap);
- the control levers have been moved back and forth several times to lower the pressure in the cylinders.

Before starting the engine once more, make sure all fittings are fully tightened down and all lines and unions are in good condition.

If you are struck by hydraulic fluid under pressure, you may have serious reactions if not given immediate medical treatment.

1.7 SAFETY LABELS AND SIGNS

The machine bears a variety of safety signs and labels.

This section indicates where they are located and the respective hazards.

Make sure that all safety labels are legible. Clean and replace damaged and illegible signs.

Clean the labels with a rag, water and soap. Do not use solvents or petrol to do so.

If the label is attached to a part which must be replaced, take care to fit the new part with a new label.

Symbol illustrated

Warning, explanation

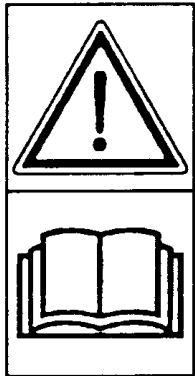

① **Caution!**
Read the manual before operating, servicing or transporting the machine.

Symbol illustrated

Warning, explanation



② The sign indicates the danger of burns due to contact with high temperature parts. Do not touch hot parts while the machine is operating or before having given it time to cool down after being switched off; use suitable safety equipment if necessary.

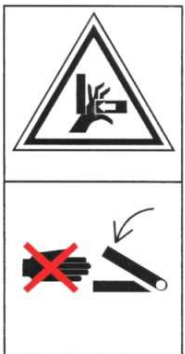

③ The sign indicates the shearing hazard associated with the bucket. Keep your hands away from the bucket arm while the bucket is operating.



④

The sign indicates the hazard of being struck by objects thrown up by the tracks during movement. Read the manual before using the machine to ensure all operations are done correctly.



⑤ The sign indicates the hazard of crushing by unexpected movements of the accessory or bucket (if present). Keep a safe distance when the machine is operating. Always completely lower the bucket and accessory before leaving the machine unsupervised.

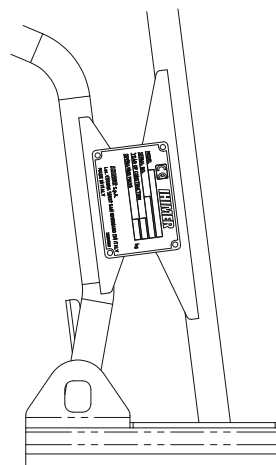

The nameplate on the chassis gives the manufacturer's data and machine serial number.



2 OPERATING INSTRUCTIONS

2.1 CONTROLS

MACHINE CONTROLS WITH DOUBLE PUMP

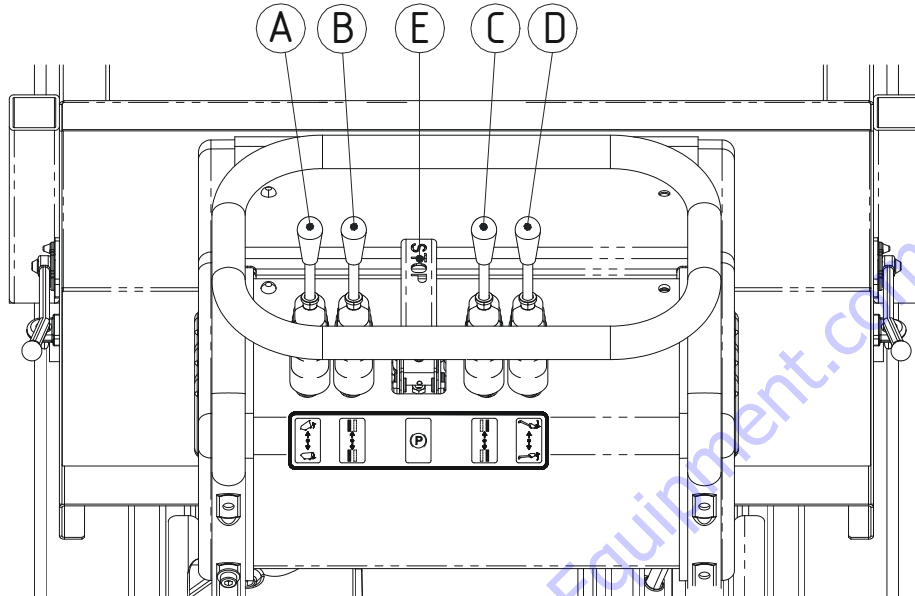

(A) Accessory lever

(B) Drive lever (LH)

(C) Drive lever (RH)

(D) Bucket lever

(E) Parking brake lever

MACHINE CONTROLS WITH TRIPLE PUMP

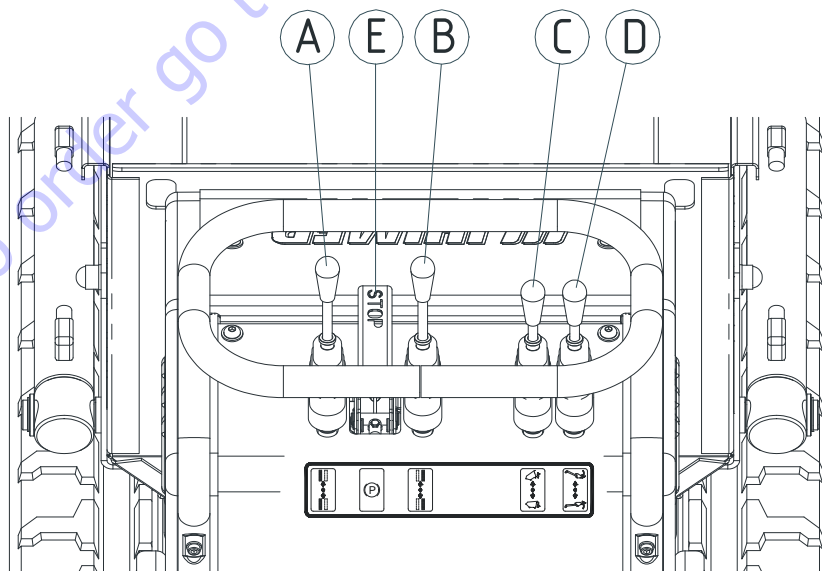

(A) Drive lever (LH)

(B) Drive lever (RH)

(C) Accessory lever

(D) Bucket lever

(E) Parking brake lever

2.1.1a DRIVING THE MACHINE (Levers B and C machine with double pump)

1. Move the engine speed lever to the desired position.
2. Operate the RH and LH drive levers as follows.

STRAIGHT**- FORWARDS**

Gradually push both levers to drive forwards. The machine will move forwards.

- STOP

Slowly pull both levers back to the center position to stop the machine.

- REVERSE

Pull both levers back to drive in reverse. The machine will move backwards.

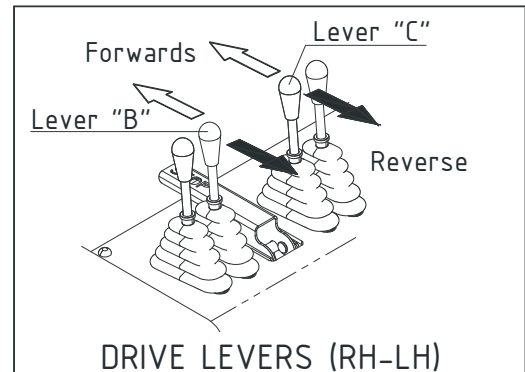
**STEERING**

To steer, operate the levers as follows.

- Steer to the left.

Push the RH lever (C) forwards to steer to the left while driving forwards, pull it back to steer left in reverse.

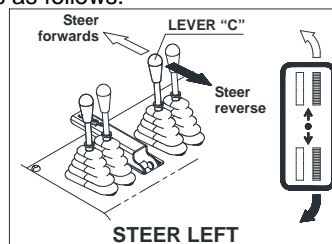
**- Steer to the right.**

Push the LH lever (B) forwards to steer to the right while driving forwards, pull it back to steer right in reverse.

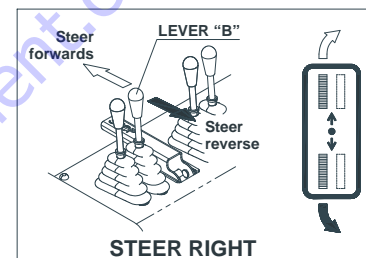
**TURNING IN PLACE****- Turn to the left.**

Push the RH lever (C) forwards while pulling the LH lever (B) back. This turns the machine quickly in place towards the left.

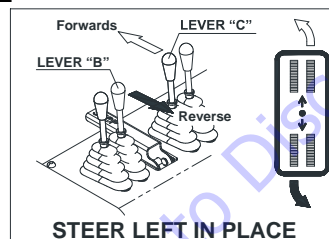
**- Turn to the right.**

Push the LH lever (B) forwards while pulling the RH lever (C) back. This turns the machine quickly in place towards the right.

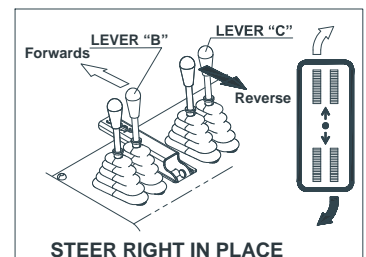

2.1.1b DRIVING THE MACHINE (Levers A and B machine with triple pump)

3. Move the engine speed lever to the desired position.
4. Operate the RH and LH drive levers as follows.

STRAIGHT**- FORWARDS**

Gradually push both levers to drive forwards. The machine will move forwards.

- STOP

Slowly pull both levers back to the center position to stop the machine.

- REVERSE

Pull both levers back to drive in reverse. The machine will move backwards.

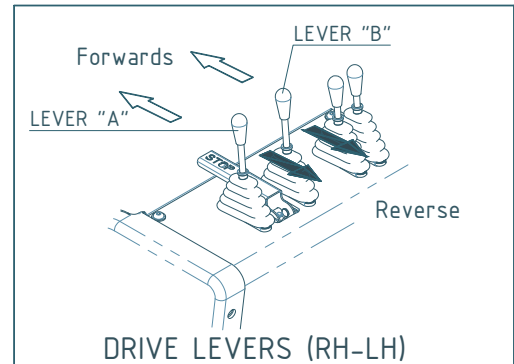
**STEERING**

To steer, operate the levers as follows.

- Steer to the left.

Push the RH lever (C) forwards to steer to the left while driving forwards, pull it back to steer left in reverse.

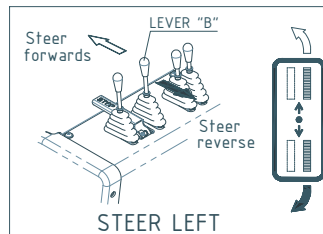
**- Steer to the right.**

Push the LH lever (B) forwards to steer to the right while driving forwards, pull it back to steer right in reverse.

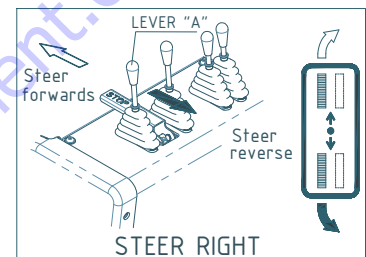
**TURNING IN PLACE****- Turn to the left.**

Push the RH lever (C) forwards while pulling the LH lever (B) back. This turns the machine quickly in place towards the left.

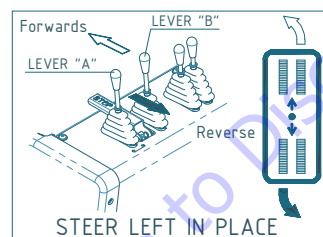
**- Turn to the right.**

Push the LH lever (B) forwards while pulling the RH lever (C) back. This turns the machine quickly in place towards the right.

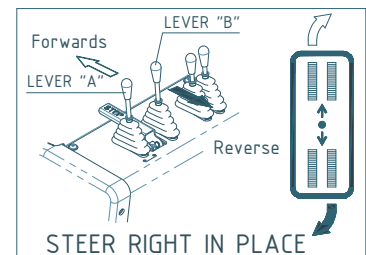
**PRECAUTIONS WHEN DRIVING ON SLOPES****WARNING**

- LOWER THE ENGINE SPEED.
- DO NOT CHANGE DRIVING SPEED.
- IF POSSIBLE, DRIVE WITH THE TRACKS POINTING UP OR DOWN HILL, NOT ACROSS THE SLOPE.
- DO NOT STEER ON SLOPES, AS THIS CAN CAUSE THE MACHINE TO TIP OVER OR SKID SIDWAYS.
- IF THE MACHINE IS EQUIPPED WITH A BUCKET, KEEP IT AS CLOSE TO THE GROUND AS POSSIBLE WHEN DRIVING ON SLOPES.

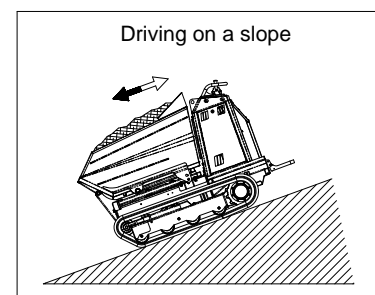
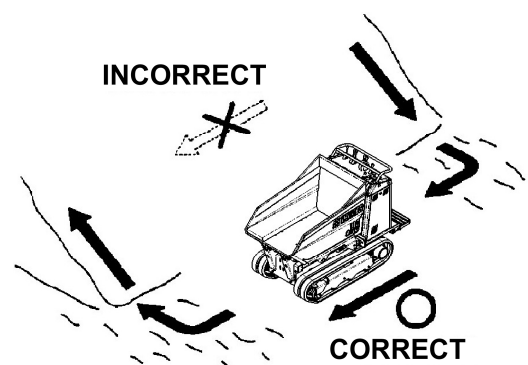

2.1.2a ACCESSORY LEVER (*Lever A machine with double pump*)



WARNING

WITH THE ENGINE OFF, MOVING THIS LEVER BACK LOWERS THE ACCESSORY UNDER ITS OWN WEIGHT.

Raising the accessory: Push the lever forwards to raise the accessory.

Lowering the accessory: Pull the lever back to lower the accessory.

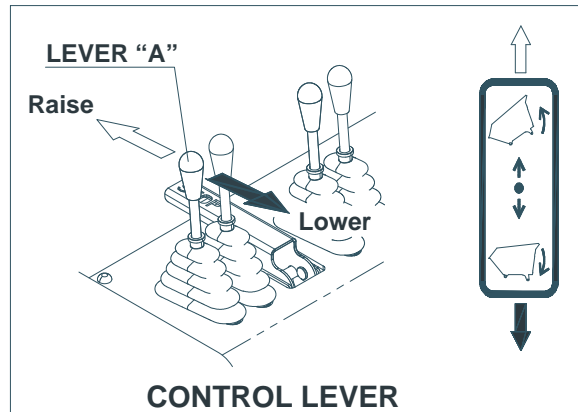

2.1.3a BUCKET LEVER (OPTIONAL) (*Lever D machine with double pump*)



WARNING

WITH THE ENGINE OFF, PUSHING THIS LEVER FORWARDS LOWERS THE BUCKET UNDER ITS OWN WEIGHT.

Lower bucket: push the lever forwards to lower the bucket and use it for collecting material.

Raise bucket: pull the lever back to raise the bucket and dump the material in the skip.

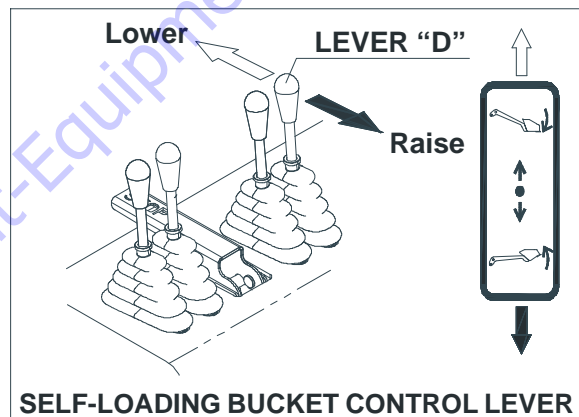

2.1.4a PARKING BRAKE LEVER (*Lever E machine with double pump*)

Engage brake: move the lever to the vertical position.

Disengage brake: move the lever to the horizontal position

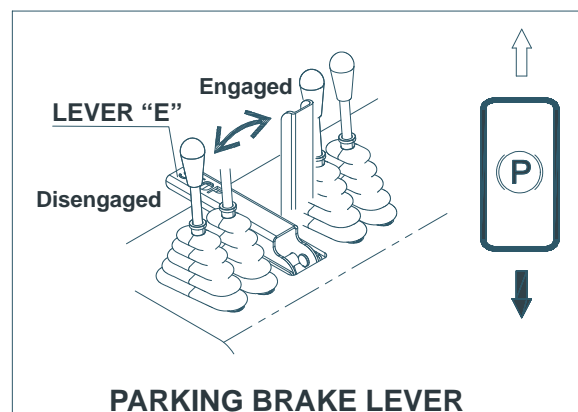

2.1.2b ACCESSORY LEVER (*Lever C machine with triple pump*)**WARNING**

WITH THE ENGINE OFF, MOVING THIS LEVER BACK LOWERS THE ACCESSORY UNDER ITS OWN WEIGHT.

Raising the accessory: Push the lever forwards to raise the accessory.

Lowering the accessory: Pull the lever back to lower the accessory.

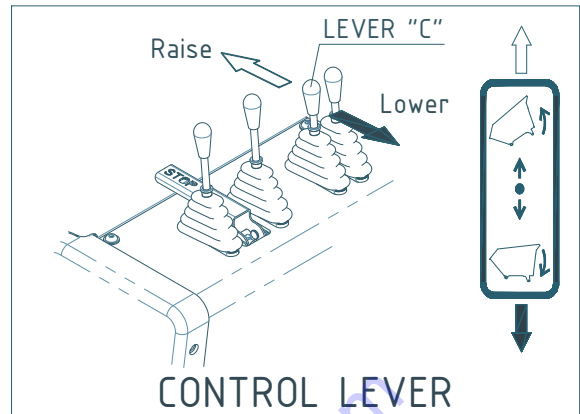
2.1.3b BUCKET LEVER (OPTIONAL)(*Lever D machine with triple pump*)**WARNING**

WITH THE ENGINE OFF, PUSHING THIS LEVER FORWARDS LOWERS THE BUCKET UNDER ITS OWN WEIGHT.

Lower bucket: push the lever forwards to lower the bucket and use it for collecting material.

Raise bucket: pull the lever back to raise the bucket and dump the material in the skip.

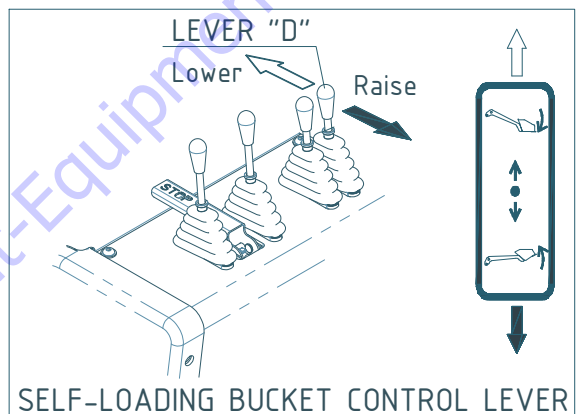
2.1.4b PARKING BRAKE LEVER (*Lever E machine with triple pump*)

Engage brake: move the lever to the vertical position.

Disengage brake: move the lever to the horizontal position

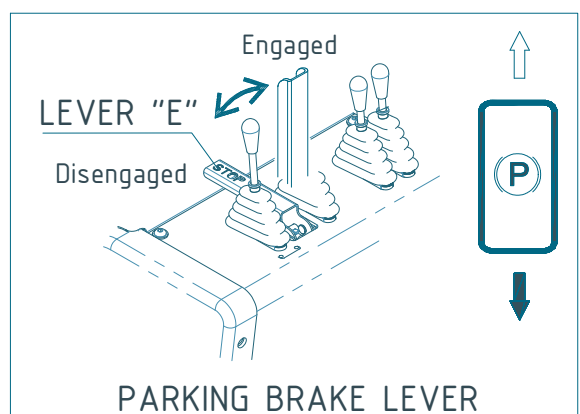

2.2 USING THE COMBUSTION ENGINE

CHECKS BEFORE STARTING

Check the hydraulic fluid, engine oil and fuel levels.

For how to do these checks, refer to "Daily checks" elsewhere in this manual.

This paragraph gives the basic operations for starting and stopping the engine. We recommend that you also read the **engine manufacturer's** manual for further information.

2.2.1 STARTING THE PETROL ENGINE

1. Set the fuel valve to "ON".
2. Move the air lever to the closed position.
3. Set the accelerator lever to the half way point.

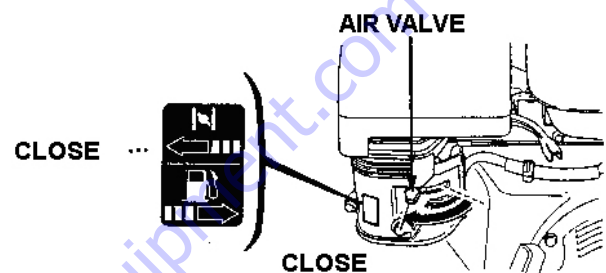
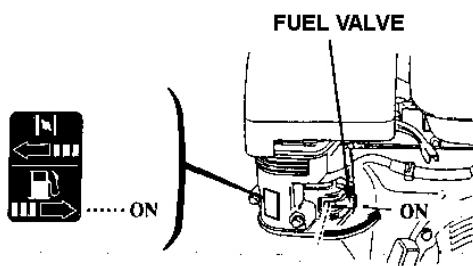

NOTE: Do not use the air lever if the engine is warm and the ambient air temperature is sufficiently high.

4. Move the accelerator lever slightly to the left.
5. Start the engine.

- With PULLEY starting:

Move the engine's ignition switch to "ON-I".

Pull the starter cord until you feel a certain resistance, then pull it hard.

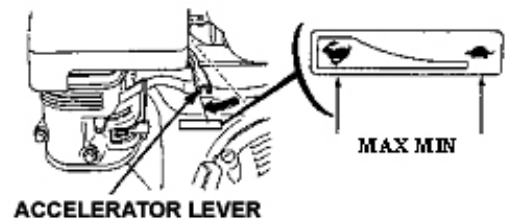

CAUTION:

Do not allow the cord's handle to bang against the engine when it rewinds. Let it wind back gently, to avoid damage to the starter.

6. When the engine has started, move the air lever to "MIN".

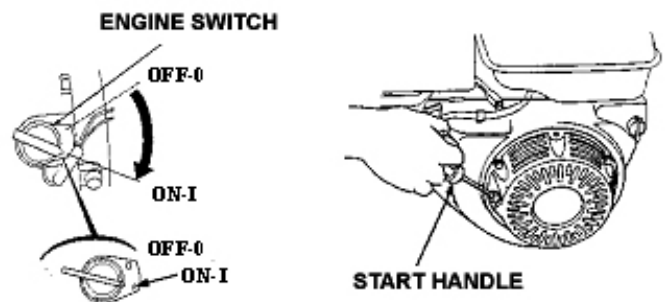

2.2.2 STOPPING THE PETROL ENGINE

1. Run the engine at **LOW SPEED** for a few minutes. This allows the engine to cool before switching off.
2. Switch the engine off by setting the engine ignition switch to "0-OFF". Refer to the engine manufacturer's manual.

2.3 PREHEATING THE MACHINE

As with all hydraulic systems, the hydraulic fluid must be at temperature before you start work.

The time required for the fluid to heat can be employed in running some simple maintenance checks. Before starting work at full load, observe the following precautions scrupulously:

- 1 Allow the engine to heat up slowly at low engine speed for 5 minutes.
- 2 Actuate the cylinder of the accessory to heat up the hydraulic equipment more quickly.

2.4 LIFTING THE MACHINE



WARNING

- **USE APPROPRIATE CABLES AND EQUIPMENT FOR LIFTING. THE LIFTING CABLES MUST BE LONG ENOUGH TO AVOID CONTACT WITH THE MACHINE ITSELF ALONG THEIR LENGTH.**
- **USE LIFTING EQUIPMENT ABLE TO BEAR THE WEIGHT OF THE MACHINE (POINT 5).**
- **NEVER LIFT THE MACHINE WITH ANYONE ON BOARD.**
- **USE SIGNS AND OTHER NOTICES TO MARK OFF THE LOADING AREA.**
- **ALWAYS USE CABLES AND OTHER EQUIPMENT RATED FOR LOADS OF MORE THAN 1 TON.**

LIFTING PROCEDURE.

The machine is fitted with 4 lifting points marked with labels, two of which are close to the drive levers and the other two on the front of the accessory.

1. Place the machine at ground level with the accessory lowered and the bucket fully up (if present).
2. Stop the engine
3. Connect the harness to the 4 lifting points using 4 snap hooks rated for the load.
4. Secure the harness to the lifting equipment.
5. Make sure there are no obstacles or persons around the machine
6. Lift the machine a few cm and check that the load is well balanced.

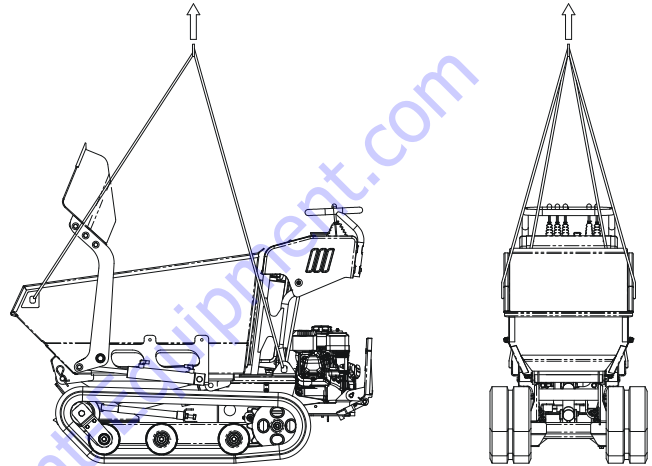

2.5 LOADING AND UNLOADING THE MACHINE



WARNING

- **LOAD AND UNLOAD THE MACHINE, IF AT ALL POSSIBLE, ON STABLE, FLAT GROUND.**
- **USE A SUFFICIENTLY LONG, WIDE AND THICK RAMP.**
- **TO PREVENT THE MACHINE SLIPPING ON THE RAMP OR DURING TRANSPORT, CLEAN OFF ALL GREASE, OIL, ICE AND OTHER MATERIAL OFF THE RAMP AND TRUCK BED BEFORE LOADING THE MACHINE.**
- **NEVER USE THE ACCELERATOR AT FULL THROTTLE WHEN LOADING OR UNLOADING THE MACHINE FROM A TRUCK.**
- **NEVER STEER ON LOADING RAMPS. IF NECESSARY, DRIVE DOWN OFF THE RAMP TO CHANGE DIRECTION.**

LOADING THE MACHINE ONTO A TRUCK

To load or unload the machine, **ALWAYS** use ramps and proceed as follows.

1. Lock the wheels of the truck before starting.
2. Lower the truck's sides.
3. Lock the ramps to the truck. The ramps must be at less than 15° to the ground. The ramps must be wide enough for the tracks.
4. Position the machine so that it is pointing straight up the ramps. Do not operate any lever, except for the drive levers, when the machine is on the ramps.
5. Keep the center of gravity of the machine within the area of the ramps themselves.
6. Make sure the ramps are stable.

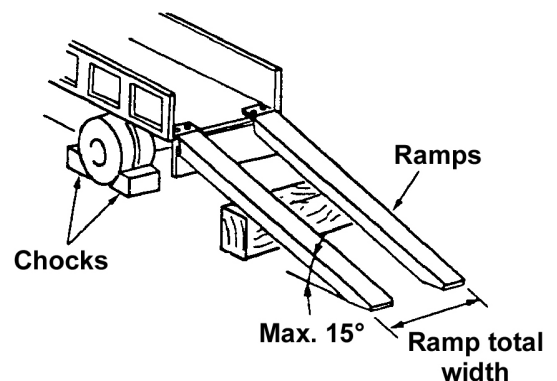

SECURING THE MACHINE FOR TRANSPORT

1. Switch off the engine.
2. Engage the parking brake.
3. Secure the tracks and machine to the load bed with chains or steel rope.

2.6 EQUIPMENT

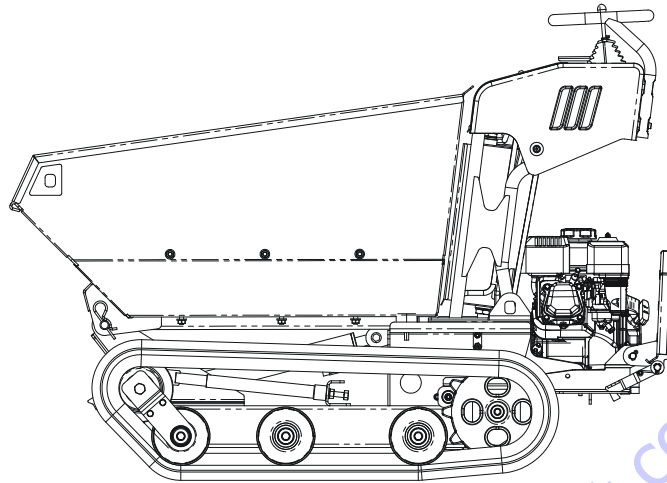

SKIP

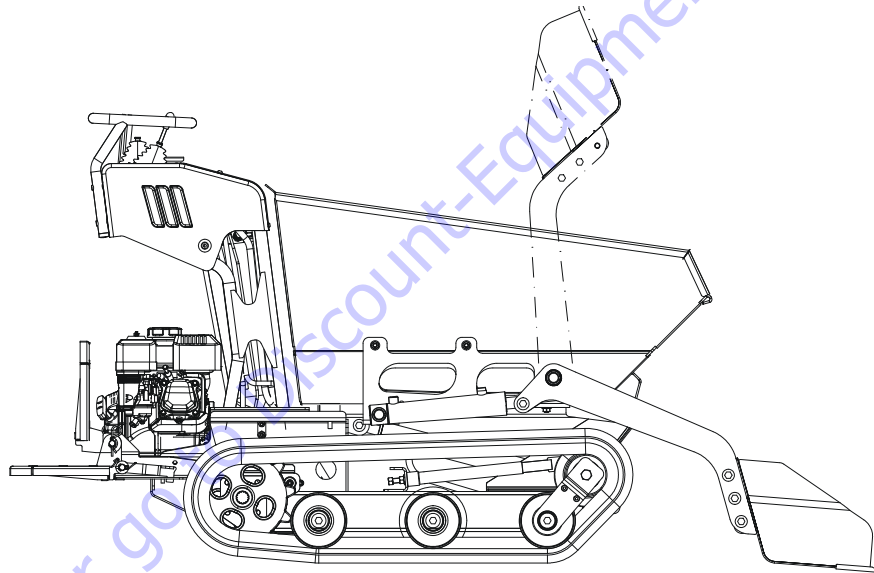

SKIP WITH BUCKET

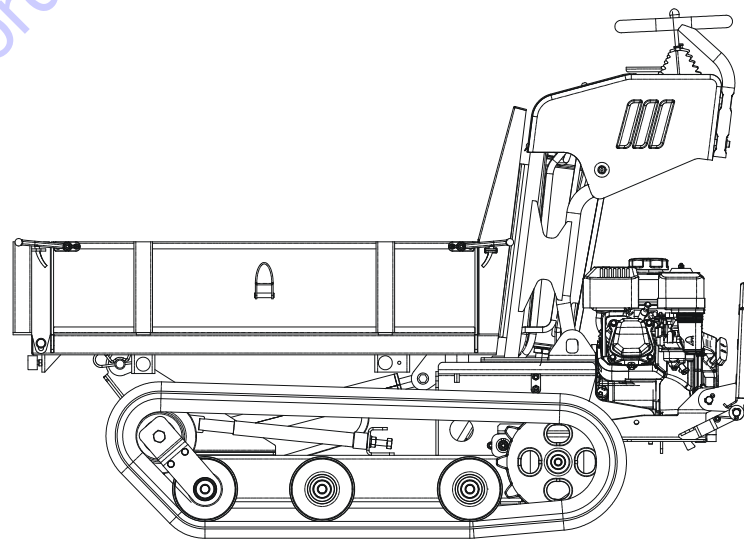

LOADING PLATFORM

2.7 OPERATION AND ACCESSORIES

2.7.1 SKIP

The 0.22 m³ skip is the accessory most suited for moving debris, earth, gravel, aggregate, conglomerate, cement, and all other bulk materials used on work sites. The skip can be combined with the self-loading bucket. Once the skip is full, move the machine to the dumping point and proceed as explained at point 2.1.2. If the machine is equipped with a self-loading bucket, move this to the highest position and check that it does not interfere with any structures during operation.

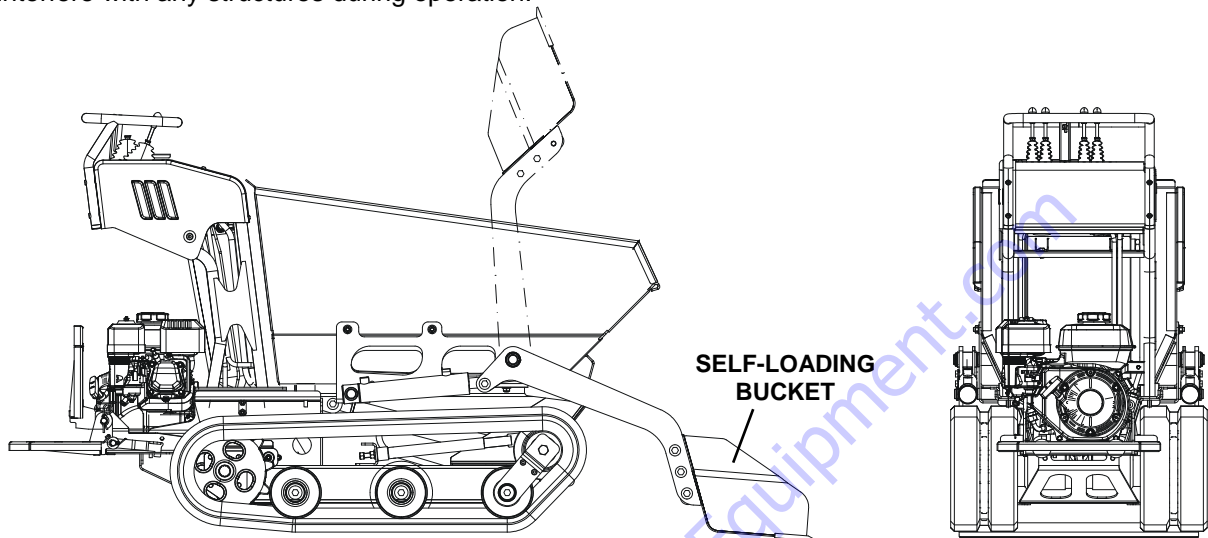

2.7.2 SELF-LOADING BUCKET



WARNING

BEFORE OPERATING THE BUCKET, MAKE SURE THERE IS NO-ONE IN THE WORK AREA.

The self-loading bucket, mounted directly to the skip, can be used only for loading debris and bulk materials. IT MAY NOT BE USED FOR DIGGING. To load:

- Lower the bucket to the ground.
- Move the machine slowly up to the pile of debris until the bucket is full.
- Raise the bucket, and slow down when the material starts unloading to prevent it falling out of the skip and onto the driving position.

2.7.3 LOADING PLATFORM

The loading platform is a multipurpose accessory, suited to a variety of uses in construction, farming, nursery and civil applications. The special configuration of the sides when fully open enables it to be used for moving large size slabs and panels. A large compartment under the platform is ideal for transporting tracks, ropes, tools, etc.

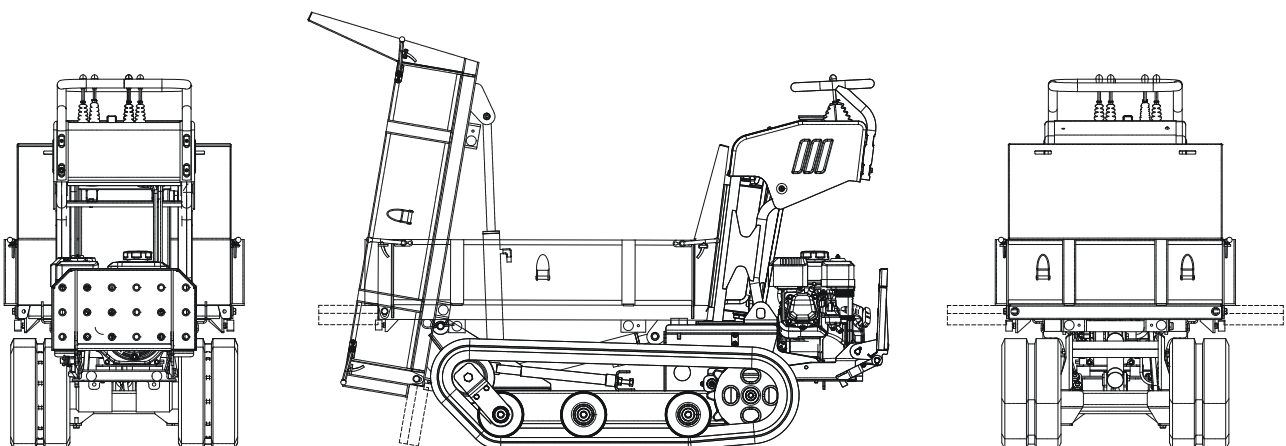

2.7.4 FOOT PLATE (OPTIONAL)

The footplate hinges to the driving chassis. When closed, it enables safe control of the machine from the ground without the risk of colliding with the operator's legs. When open, it allows the operator to operate the machine from on-board. A shock absorber system reduces vibrations to the legs and feet. For total operator safety, the footplate is equipped with a locking system (spring loaded) which prevents it from closing unexpectedly.

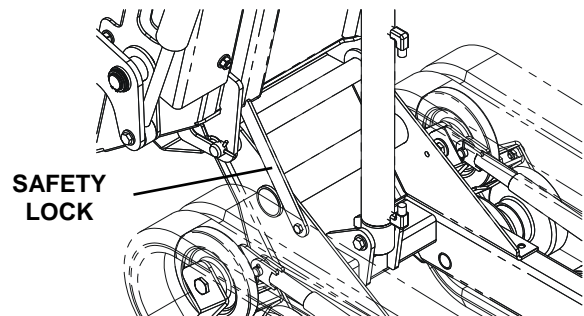
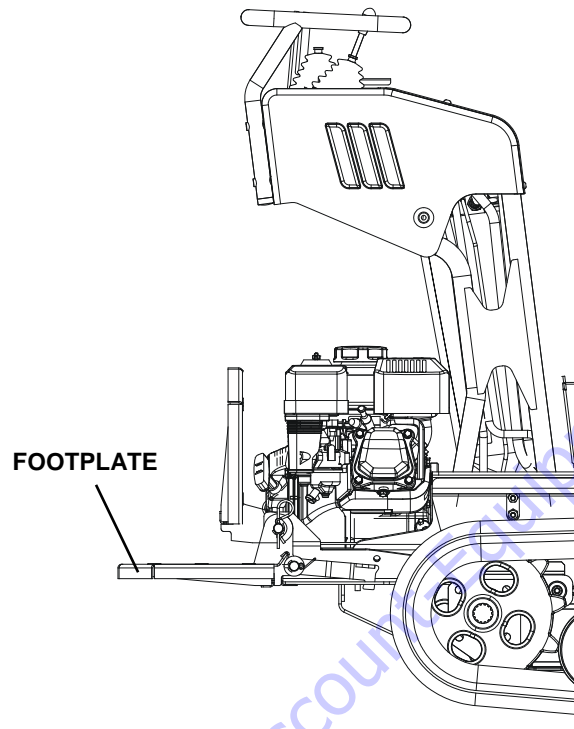

2.7.5 ASSEMBLING THE SELF-LOADING BUCKET (OPTIONAL)

The self-loading bucket should be installed only in a well-equipped workshop by expert staff. Incorrect installation can cause damage and injury.

- 1 Place the machine on flat, clean ground.
- 2 If the machine is already in use, clean the skip all other parts affected by the installation.
- 3 Start the engine, raise the skip, fit the safety lock and stop the engine.
- 4 Remove guards (A) and (B) from the hydraulic circuit.

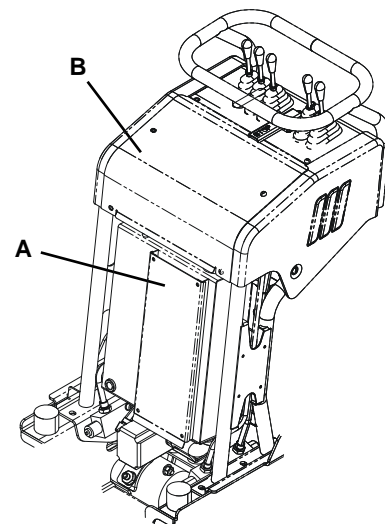

- 5 Remove bolts (1) and nuts (2) on the sides of the skip and fit the RH/LH bucket arm mounting plates (C-D) to the side of the skip with the same nuts and bolts (tighten fully down).

Caution! The rounded heads of the bolts should be inside the skip.

- 6 Fit the RH/LH bucket arms (E-F) onto the pins on plates. Fit the flat washer dia. 25 (3) and secure it with a circlip (4).
7 Assemble the arm cylinders and secure their bases to the pins on the plates. Fit the flat washer dia. 25 (3) and secure it with a circlip (4).

Caution! Make sure the fittings for the hydraulic lines are facing upwards.

- 8 Secure the heads of the cylinders to the bucket arms with the provided pins. Fix the pins with M10x25 bolts (5) and flat washers dia. 10 (6).

Caution! Fit the pins from the side equipped with the mounting plates so that the heads of the pins are locked in place once they are located.

- 9 Place the bucket on the ground. Secure the bucket to the arms using M10x40 bolts with nuts and washers. Check the alignment of the bucket and that it is correctly mounted to the arms. Tighten all bolts fully down.

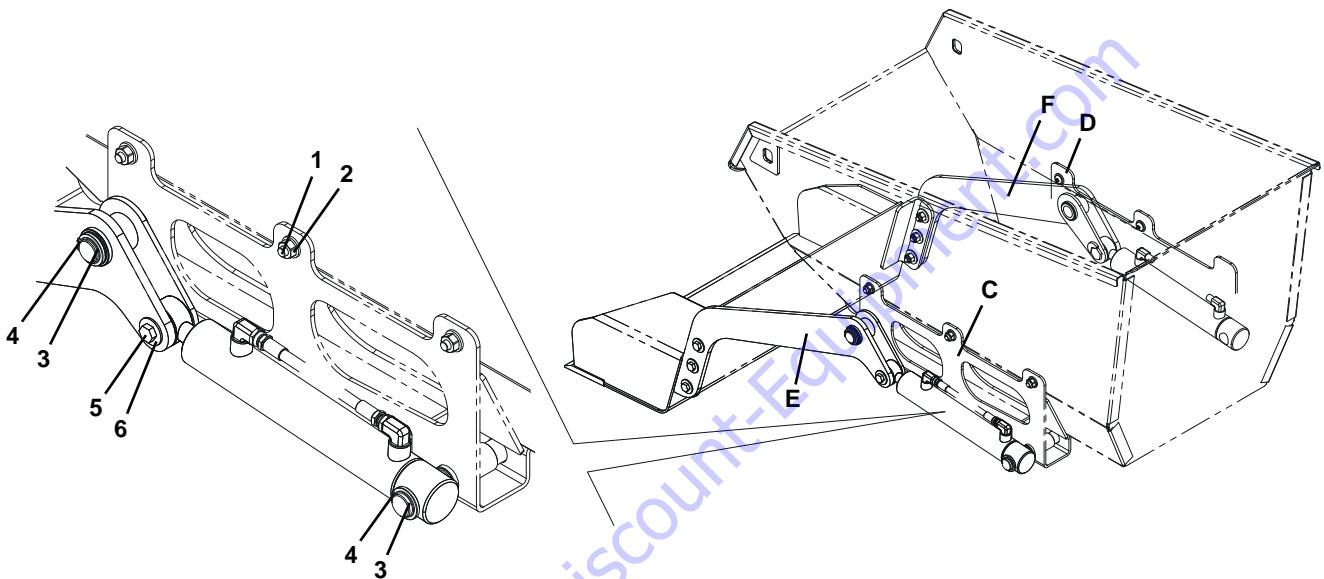

- 10 Remove the caps on the manifold after having cleaned the surface around them, and replace them with straight fittings and gaskets. Hook up the T fittings.

- 11 Route the lines in sequence as shown in the diagram. Route the lines to the bucket cylinders, taking care not to overlap or cross them. Secure them with the provided collars.

Caution! Make sure that the protective sheathing is located on the cylinder coupling side. Check the installation sequence carefully.

- 12 Once you are satisfied with the installation, fully tighten down all fittings, lines and collars.

- 13 Start the engine, remove the safety lock and lower the skip, actuate the bucket circuit carefully and check it operates properly in response to the controls (point 2.1.3). If it is operating correctly, pressurize the circuit with the cylinders at full stroke.

- 14 Check for leaks at the fittings and unions. Clean all oil off the various surfaces.

- 15 Restore guards (A) and (B) to the hydraulic circuit.

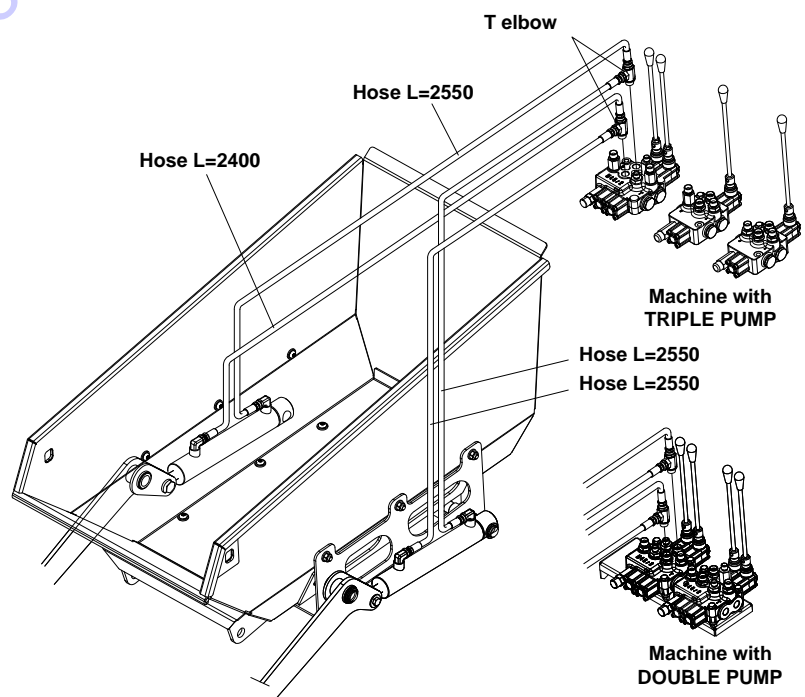

The machine is ready for use.

2.7.6 PARKING BRAKE

The parking brake (1) is mounted on the LH track chassis and engages with the teeth of the track's drive wheel.

The brake is operated manually with the lever (E) on the control console between the drive levers.

When the brake is engaged, the lever is vertical, thus preventing the drive levers being used, so that the brake has to be disengaged before the drive levers can be operated.

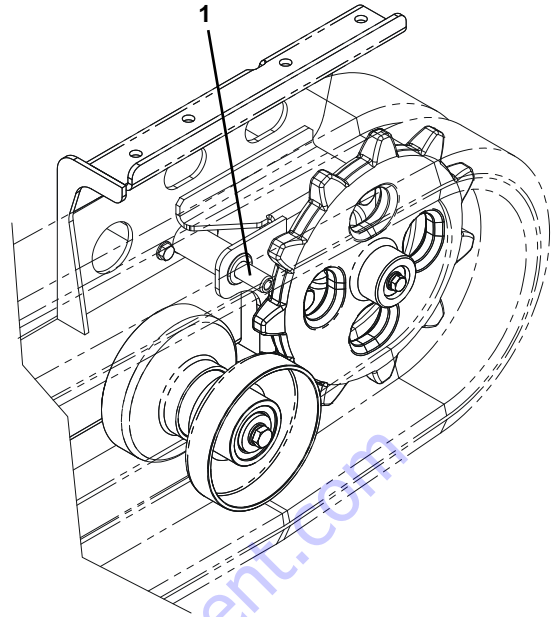

MACHINE WITH DOUBLE PUMP

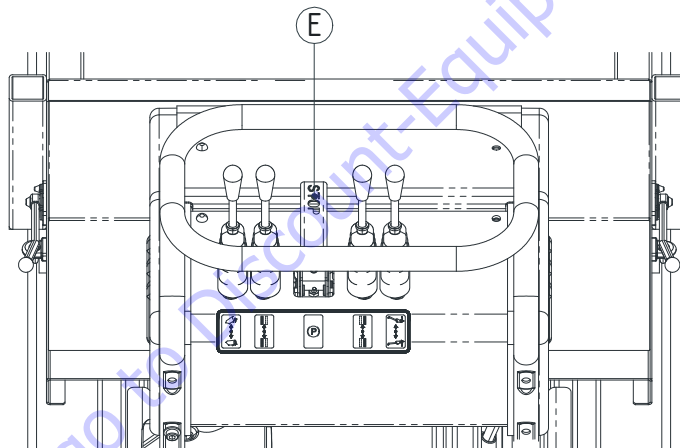

MACHINE WITH TRIPLE PUMP

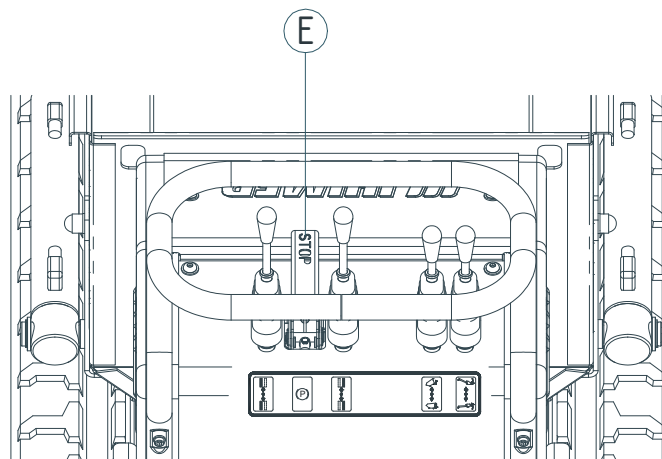

2.8 ACCESSORY REPLACEMENT PROCEDURE

2.8.1 DISENGAGING AND REMOVING ACCESSORIES

- 1) Place the machine on flat ground.
- 2) Engage the parking brake.
- 3) Raise the accessory to full stroke, then lower it so that the piston returns by 10-20 mm.
- 4) Switch off the engine.
- 5) Make sure you have the tools you require for the disassembly procedure (mallet, wrenches, etc.).
- 6) Hook the accessory to a lifting device with two linkages (minimum load capacity 500 kg) inserted into the lifting holes (A) and tension the linkages slightly.
- 7) Release the cylinder by removing the pin (B) from its seat after having removed its bolt (1) and washers.

Warning! Support the cylinder so that it does not swing down and get damaged or injure the operator.

- 8) Raise the accessory with the linkages slightly tensioned.
- 9) Remove the pin (C) after having removed the split pin (2).
- 10) Lower the accessory to a pallet or platform on the ground.
- 11) Hook on the new accessory using the two rear holes - use the two linkage lifting device to raise it.

Warning! Use only original accessories supplied by KATO IMER and declared to be compatible with the machine in question.

- 12) Raise and move the accessory until the lug holes (3) align with the bushing holes (4).

Warning! Before mounting the equipment, clean the holes and pin of any dirt or rust.

- 13) Lightly grease or oil the pin.
- 14) Locate the pin (C) making sure to insert it from the anti-rotation plate side.
- 15) Secure the pin with its split pin (2).
- 16) Slowly lower the accessory so that it rotates towards the control console.
- 17) Move the lifting cylinder so that its hole aligns with the accessory's mounting hole.
- 18) Fit the pin (B) and secure it with the bolt (1) and washers.

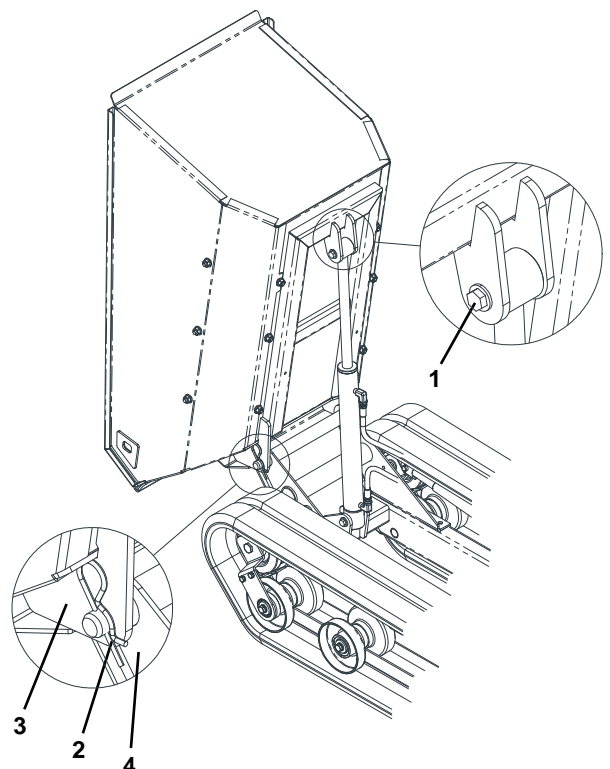
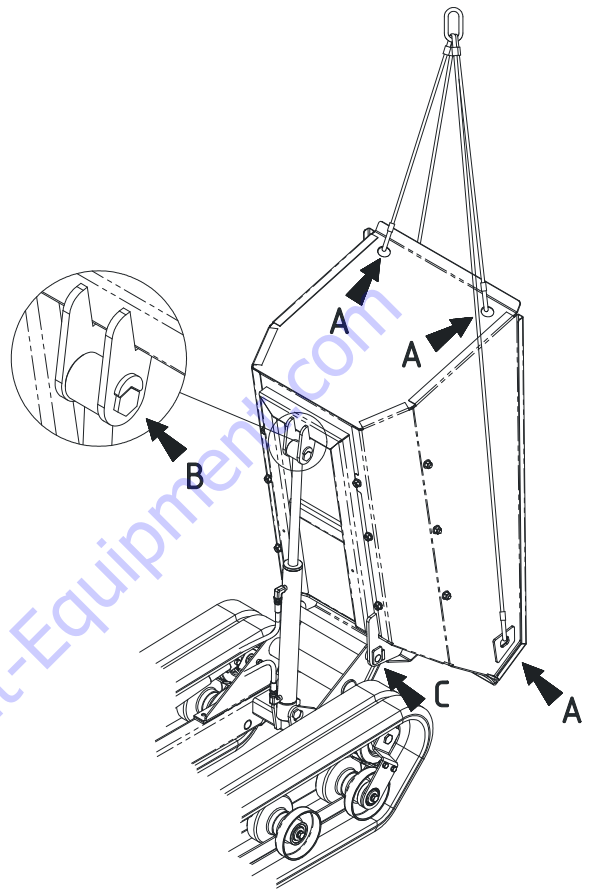

- 19) Check the assembly, and that all fasteners are properly installed and secured.
- 20) Unhook the accessory from the lifting device.
- 21) Start the engine.
- 22) Slowly lower the accessory while watching it carefully for unusual behaviour.

The machine is ready for use.

Clean and check the condition of the old accessory, then lubricate it and put it away. If you note any damage to its structure, repair it immediately. These simple precautions mean that the accessories are always compliant with safety requirements.

Proceed in reverse order when fitting new accessories.



THE SKIP AND PLATFORM CAN BE REMOVED BY HAND BY TWO PERSONS.

To order go to Discount-Equipment.com

2.8.2 LIFTING THE SKIP WITH SELF-LOADING BUCKET

USE STEEL ROPES WITH A MINIMUM LOAD CAPACITY OF 500 Kg.

**TO LIFT THE SKIP/BUCKET
ASSEMBLY, ATTACH THE
ROPES TO POINTS
“A” AND “B”.**

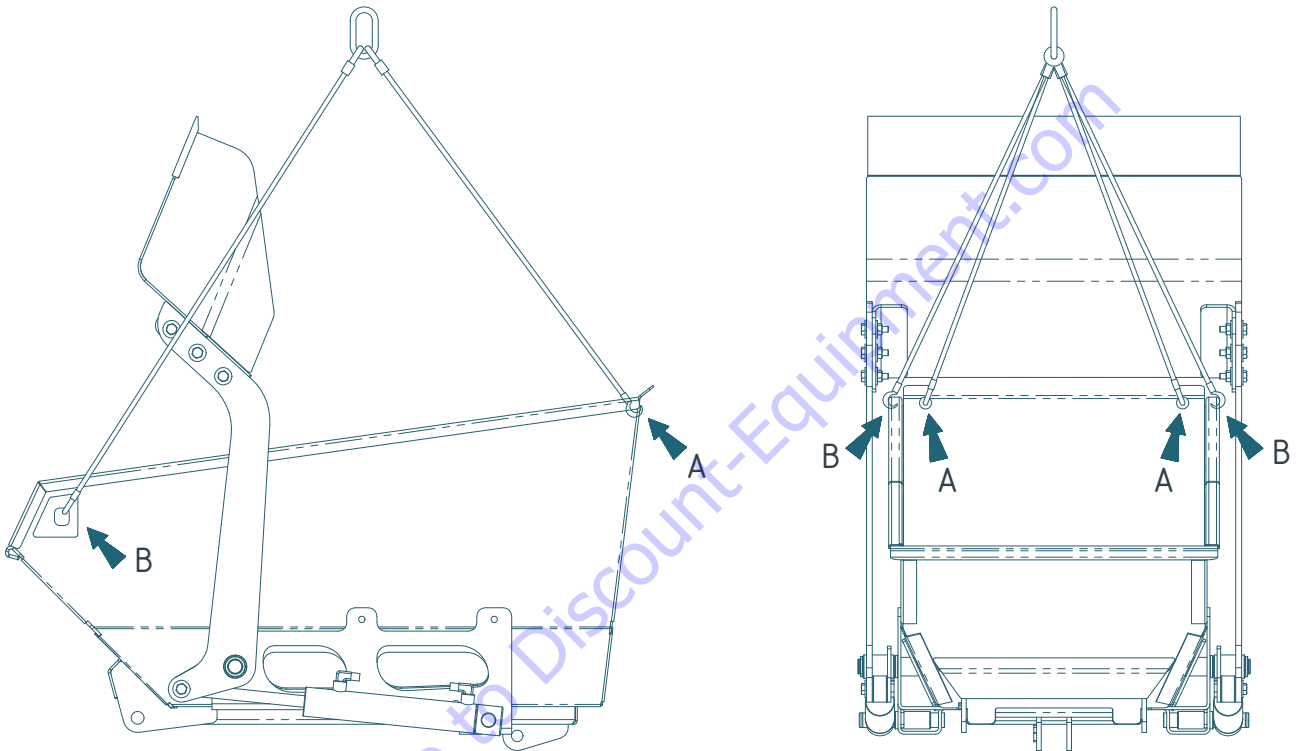

2.9 PRECAUTIONS WHEN USING RUBBER TRACKS

STRUCTURE OF RUBBER TRACKS



WARNING

IF A CRACK IN THE CASING REACHES THE METAL WIRES, THE LATTER MAY RUST AND CUT THEMSELVES. VULCANISE THE TRACK AS SOON AS YOU SEE ANY CRACKS AT ALL.

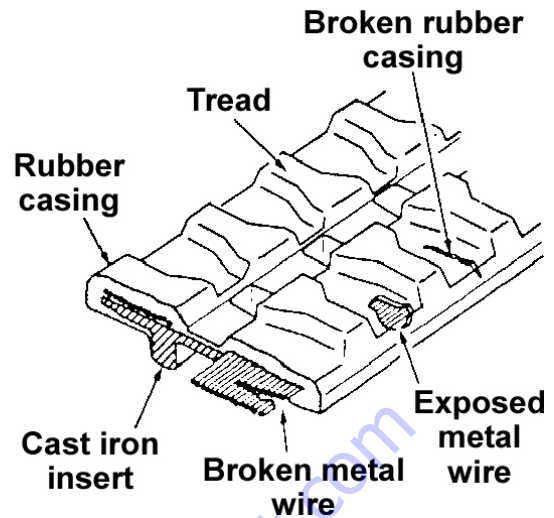

OPERATIONAL PRECAUTIONS.

1. Adjust the tension of the tracks frequently.
 - Insufficient tension will cause them to jump off their wheels and also wears down the drive wheels and metal inserts of the tracks themselves.
 - Excessive tension increases drive friction and wears the undercarriage as well as causing the tracks to fail prematurely.
2. To avoid damaging rubber tracks, do not use them in the following conditions
 - quarries or rough rocky ground
 - bars and metal waste
 - edges or corners of metal or concrete structures
 - fire and other sources of heat
 - driving on concrete flooring or against walls
3. Clean any diesel, hydraulic fluid and grease off the tracks.
4. Do not turn quickly when using rubber tracks.
5. If the machine is out of service for a long time (3 months or more) store the rubber tracks away from direct sunlight and rain.
6. Due to the nature of the rubber itself, only operate the machine in ambient temperature of -25°C to $+55^{\circ}\text{C}$.

2.10 PARKING THE MACHINE

At the end of a day of work, proceed as follows:

PARKING THE MACHINE

Drive the machine to a secure location on flat ground.

1. Move the accelerator lever forwards to reduce engine speed
2. Release the drive levers so the machine stops.
3. Lower the bucket (if present) to the ground and apply slight pressure.
4. Engage the parking brake.
5. Switch off the engine.

IN VERY COLD (SUBZERO) CONDITIONS

If you expect very low subzero temperatures, clean all mud and dirt off both tracks and park the machine on wooden planks.

3 MAINTENANCE

3.1 MAINTENANCE PERIODS

Inspection point	Service
When required	
Tracks	Check and adjust tension
Daily (every 8 hours of operation)	
Engine oil	Check oil level
Hydraulic fluid reservoir	Check hydraulic fluid level
Fuel tank	Check fuel level
Machine	Check general condition daily
Every 50 hours of operation (before the above services)	
Engine	Clean air filter element
Every 200 hours of operation (before the above services)	
Engine	Change oil
Engine	Clean fuel sediment sump
Air filter	Change air filter element
Hydraulic circuit	Change filter
Every 600 hours of operation (before the above services)	
Hydraulic fluid	Change fluid
The stated intervals depend on the conditions of use of the machine: very dusty conditions require more frequent service of the air filter.	

3.2 RECOMMENDED LUBRICANTS TABLE

Position	Quantity	Characteristics
HONDA engine GX200	Max. 0.6 litres	SAE 10W-30
HYDRAULIC FLUID	Total quantity 12 litres Reservoir capacity 10 litres	LONG LIFE HYDRAULIC FLUID ISO N° 46

3.3 CHECKS AND MAINTENANCE WHEN NECESSARY

3.3.1 CHECK TRACK TENSION

When the tracks are clearly loose or are jumping the drive wheel teeth, check their tension.

3.3.2 ADJUSTING THE TRACK TENSION

1. Slacken off counter nut A counterclockwise, tighten down bolt B until you obtain the distance given in the figure between the head of bolt B and the tensioner roller pin.
2. Tension both tracks.
3. To make the tension even on both sides, move the dumper forwards and back and check the tension on both sides once more.
4. Once you are satisfied, tighten down counter nut B again.
5. Finally, check once more that both tracks are equally tensioned.

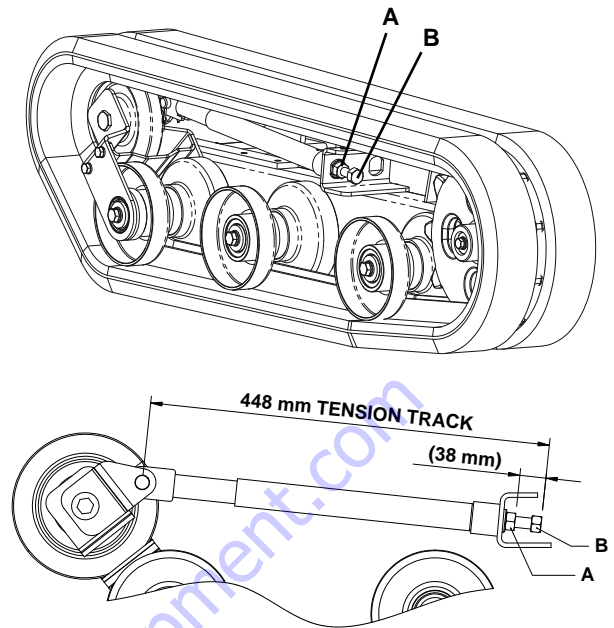

3.3.3 SERVICING RUBBER TRACKS



WARNING

- RUBBER TRACKS MUST BE REPAIRED OR REPLACED ACCORDING TO THE FOLLOWING PRESCRIPTIONS.
- CONTACT YOUR RESELLER IF YOU NEED A TRACK SERVICING OR REPLACING.

1. DEPTH OF TREAD

Rubber tracks may be used if worn; however, if too worn, the tracks will skid and require greater engine torque. If the depth of the tread is 5 mm or less, we recommend replacing it with a new original track.

2. EXPOSED METAL WIRES

If the metal wires of a rubber track are exposed due to damage or wear, replace the track with a new original one.

3. CUT METAL WIRES

If any of the metal wires are cut, replace the track immediately. If you continue to use a rubber track with cut wires, it may fail suddenly and cause a serious accident.

4. CRACKS IN THE RUBBER CASING

If you note a crack of 30 mm in length or more, and 8 mm in depth or more, repair the track immediately. If you can see the metal wires, even if the crack is smaller, repair the track immediately. Otherwise, water entering the crack can rust the wire and cause the track to fail.

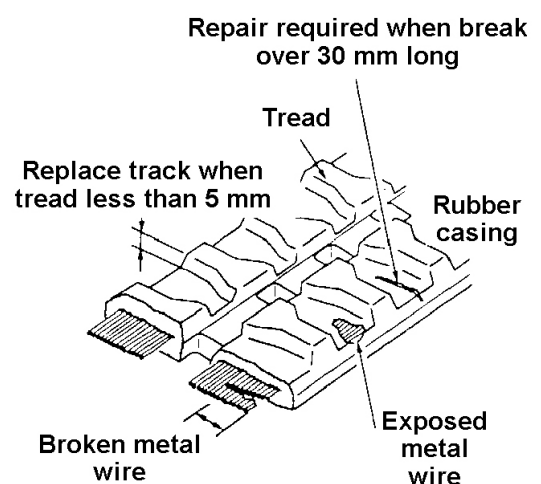

3.4 DAILY CHECKS AND MAINTENANCE



DANGER

- CHECK THE OIL LEVEL WITH THE ENGINE SWITCHED OFF. NEVER CHECK THE OIL LEVEL WITH THE ENGINE RUNNING.
- TO AVOID PROBLEMS WITH THE ENGINE, NEVER EXCEED THE MAXIMUM OIL LEVEL. EXCESS OIL CAN CAUSE THE ENGINE TO FAIL.
- NEVER START THE ENGINE WHEN THE OIL LEVEL IS OVER THE MAXIMUM OR BELOW THE MINIMUM.

3.4.1 ENGINE OIL LEVEL AND CHANGE



CAUTION

- DO NOT CHECK OR CHANGE THE OIL WHEN IT IS HOT.
- HOT OIL AND HOT PARTS CAN CAUSE BURNS. DO NOT TOUCH HOT PART OR HOT OIL.
- TO AVOID PROBLEMS WITH THE ENGINE, NEVER EXCEED THE MAXIMUM OIL LEVEL. EXCESS OIL CAN CAUSE THE ENGINE TO FAIL.
- NEVER START THE ENGINE WHEN THE OIL LEVEL IS OVER THE MAXIMUM OR BELOW THE MINIMUM.

Check the engine oil level at least fifteen minutes after the engine has been switched off. Change the oil completely after the first 20 hours of operation. See the engine instruction manual for how to check the oil level.

3.4.2 HYDRAULIC FLUID RESERVOIR LEVEL



CAUTION

- ALWAYS CLEAN THE AREA AROUND THE FILLER CAP BEFORE REMOVING IT.
- NEVER EXCEED THE MAXIMUM FLUID LEVEL.
- NEVER USE THE MACHINE WHEN THE FLUID LEVEL IS OVER THE MAXIMUM OR BELOW THE MINIMUM.

1. Place the machine on flat ground with the accessory and, if present, bucket pistons fully retracted.
2. Check that the level on the indicator (1) is at the maximum.
3. If necessary, add fluid (see "CHANGING THE HYDRAULIC FLUID" in chapter 3 - 7).

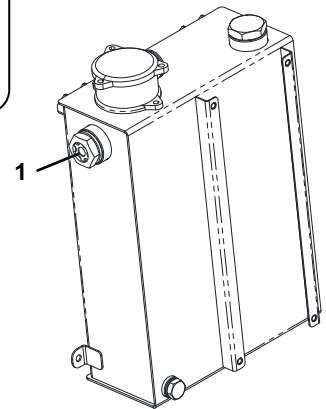

3.4.3 FILLING THE FUEL TANK



WARNING

- NEVER REFUEL WITH THE ENGINE RUNNING.
- NEVER SMOKE WHILE REFUELING.
- FUEL SPILLS ON HOT SURFACES CAN CAUSE FIRES.

Refer to the engine instruction manual.

Follow the instructions to prevent fuel leaks during operation.

Always use clean fuel containers. Use fuel without water, especially if using diesel. Take care during refueling if it is raining. To fill with fuel, remove the cap on the top of the tank and add fuel with the provided funnel. After filling, make sure the filler cap is tightly closed. Clean all fuel spills off the machine.

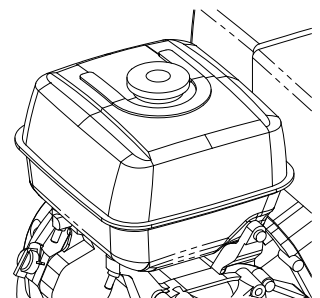

3.4.4 INSPECTING THE MACHINE

1. Check that all bolts are fully tightened down. Tighten down all loose fasteners and replace damaged ones.
2. Check for breaks where the cylinders are mounted. Repair damaged parts.
3. Check the cylinder mounts for breakage and wear. Replace/repair as necessary.
4. Check the hydraulic circuit for leaks. Check the hydraulic fluid reservoir, cylinder gaskets, lines, caps, unions and accessories. Repair any leaks.
5. Check the drive motor seals. Check them for oil leaks.
6. Thoroughly clean the engine.
7. After every use, at the end of the day, thoroughly clean all accessories (skip, platform, bucket, etc.)

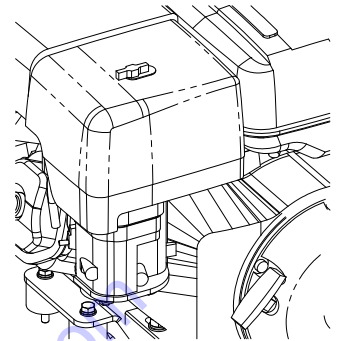

3.5 CHECKS AND MAINTENANCE EVERY 50 HOURS

3.5.1 CLEANING THE AIR FILTER ELEMENT



CAUTION

- **SERVICE THE AIR FILTER WITH THE ENGINE OFF TO AVOID DAMAGING IT.**
- **DO NOT TAP THE FILTER ELEMENT TO CLEAN IT. DO NOT USE DAMAGED AIR FILTER ELEMENTS AS THIS CAN DAMAGE THE ENGINE.**
- **WEAR A FACE MASK WHEN CLEANING THE FILTER WITH COMPRESSED AIR.**

Refer to the engine manual for how to clean the air filter.

3.6 CHECKS AND MAINTENANCE EVERY 200 HOURS

3.6.1 CHANGING THE ENGINE OIL

See paragraph 3.4 and the engine manual for how to change the engine oil.

N.B.: always follow established regulations when disposing of exhausted oil and filters.

3.6.2 CLEANING THE FUEL SEDIMENT SUMP



WARNING

FUEL SPILLS ON HOT SURFACES CAN CAUSE FIRES.

Refer to the engine manual for how to clean the fuel sump.

N.B.: always observe established regulations for the disposal of residual fluids.

3.6.3 REPLACING THE AIR FILTER ELEMENT

Refer to the engine manual for how to replace the air filter.

3.6.4 REPLACING THE HYDRAULIC CIRCUIT FILTER

The filter is located on top of the fluid reservoir.

1. Slacken off the fluid filler cap (1) to depressurise the circuit
2. Clean off the area to prevent dirt entering the filter body (2).
3. Place a container beneath the filter to collect any oil spilt while changing the filter cartridge.

N.B.: always follow established regulations when disposing of exhausted oil and filters.

4. Remove bolts (3), cover (4) and extract the cartridge (5).

N.B.: the cartridge must be replaced with a new one. Do not reuse filter cartridges.

5. Fit the new cartridge (5), push it in by hand, then fit the cover (4) and secure it with the bolts (3).
6. Start the engine and check the hydraulic fluid level
7. Repressurise the reservoir: After extending all cylinders with the fluid filler cap (1) open, close the cap.
8. Check for leaks at the filter cover (4).

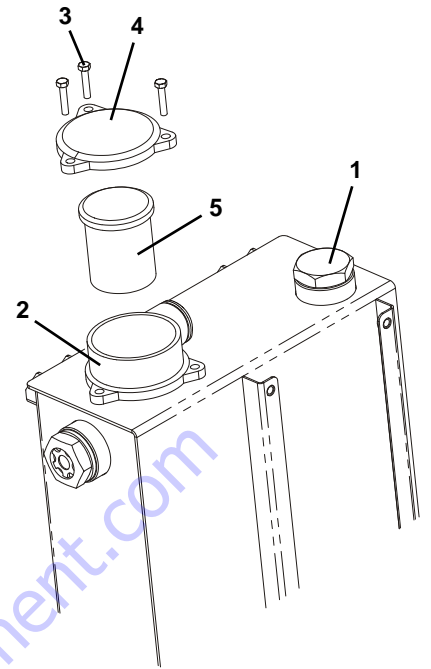

3.7 CHECKS AND MAINTENANCE EVERY 600 HOURS (1 YEAR)

3.7.1 CHANGING THE HYDRAULIC FLUID



CAUTION

- **HOT OIL AND HOT SURFACES CAN CAUSE BURNS.**
- **AT OPERATING TEMPERATURE, THE OIL RESERVOIR IS HOT AND MAY ALSO BE PRESSURISED.**
- **REMOVE THE OIL FILLER CAP (1) SLOWLY TO DEPRESSURISE THE RESERVOIR.**
- **REMOVE THE FILLER CAP ONLY WHEN THE ENGINE IS OFF AND WHEN IT IS COLD ENOUGH TO TOUCH WITH BARE HANDS.**

1. Place the machine on flat ground with the accessory and, if present, bucket pistons fully extended.
2. Fit the lock against accidental lowering and switch off the engine.
3. Clean off the area to prevent dirt entering the reservoir.
4. Slacken off the fluid filler cap (1) to depressurise the circuit.
5. Remove the drain cap (2) and allow all fluid to drain out of the circuit into a container.

N.B.: observe established regulations for the disposal of exhausted fluids and filters.

6. Clean the interior of the reservoir with fresh fluid.
7. Clean and fit the drain cap (2).
8. Fill the reservoir with hydraulic fluid. (See the table in paragraph 3 - 2 for suitable fluids).
9. Run the engine for five minutes at low speed.
10. actuate the control lever to fill the entire circuit.
11. Restore the machine to its initial condition and switch off the engine.
12. Check the level (3) and top up to the optimal level if necessary.
13. Pressurise the hydraulic reservoir with the accessory and bucket cylinders completely extended. Remove and refit the filler cap (1).
14. Lower the accessory onto the chassis, lower the bucket to the ground and switch off the engine.

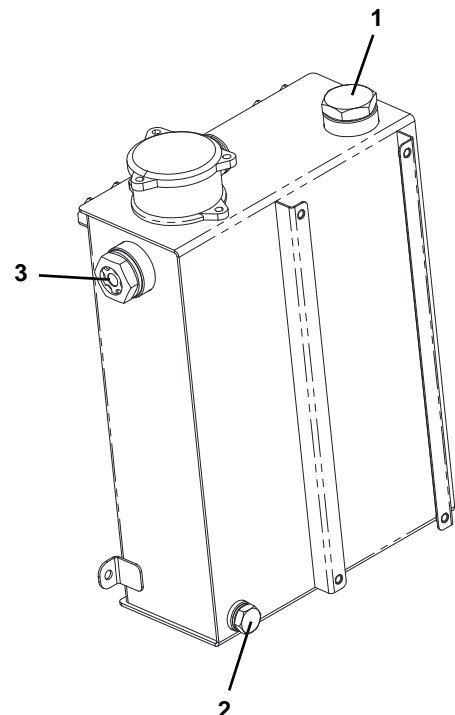

3.8 SPECIAL CONDITIONS

Special conditions (e.g. high altitude, very high or low temperatures, salt water or very dusty/sandy site) may make special maintenance necessary. If the machine is working in such conditions certain precautions must be adopted to prevent damage and excessive wear.

VERY LOW TEMPERATURES

1. Frozen condensation in the fuel tank is a hazard. Ice can block the fuel lines and stop the engine. This can be prevented by keeping the fuel tank as full as possible in cold weather. If condensation forms, empty out the tank and refill it with new fuel.
2. Always use the lubricants recommended for the operating temperature in the Lubrication section.
3. Take special care with the hydraulic fluid.



WARNING

BEFORE WORKING WITH THE MACHINE, HEAT UP THE HYDRAULIC FLUID AS EXPLAINED IN PARAGRAPH 1.1.

4. At the end of shifts, or if the machine is out of service for a period of time, park the machine on a dry, solid surface to prevent icing, such as: wood, concrete, tarmac or similar.

VERY HIGH TEMPERATURES

Here too you must take precautions to protect the battery and lubrication circuit.

1. In very high temperatures use more viscous lubricants, which do not degrade even at high temperatures. Refer to the Lubricants section for the lubricant recommended for high temperatures. Note that the engine's ability to dissipate heat also depends on the amount of oil in the crankcase, frequently check the oil level and top it up if necessary.
2. Also take care to keep the air intakes and outlets clear of leaves, paper and other materials.
3. Keep the engine clean off grease and other substances which may prevent its heat from dissipating.
4. Do not keep the engine running when the machine is not in use.

VERY SANDY/DUSTY CONDITIONS

Particles in the air can increase the rate of wear of the machine's components; particles on moving parts act as abrasives. To prevent this, lubricate the machine more frequently and clean the air intakes and filters more frequently.

1. Take care not to allow dust or sand into the hydraulic circuit; keep the reservoir tightly closed and check the filter frequently.
2. Do not allow dust or sand to enter the fuel tank.
3. The engine's air intakes and air filter must be checked frequently. The engine oil and filter must be changed more frequently to keep the oil clean.
4. Before greasing the machine with a manual grease gun, clean off all residual grease. then pump a generous amount of grease in, to clean internal parts thoroughly.
5. When working on sandy ground, lay planks or other material to support the tracks. Make sure the tracks never sink into the sand. To ensure a good grip, you may have to reverse and fill soft ground with more dense earth. More frequent maintenance depends on actual working conditions and can be established only on the basis of observations made on site, in relation to the accumulation of sand in the filters and intakes.

HIGH HUMIDITY AND SALINITY

In some areas, such as coastline, the machine may be subjected to the combined effect of humidity and salinity. Keep the machine dry and all metal surfaces well lubricated to protect exposed metal areas, electrical connections, and gaskets.

1. Remove any rust as soon as it appears, and paint the affected areas.
2. When painting is not possible, as for machined surfaces, use water-repellent grease or oil.
3. Keep bearings and other areas close to them well lubricated to prevent water entering them.
4. Never use salt water in the cooling circuit as this corrodes the lines and parts, and all affected components must be replaced.
5. Frequently wash the machine when working near to salt water, clean all moving parts with an oily rag.
6. Never work with the tracks submerged in mud or water. If this should happen, remove them, clean them and lubricate the entire undercarriage.

HIGH ALTITUDE

Changes in altitude change the fuel/air mixture used for combustion and affect the engine's performance; there is less oxygen at high altitude due to the lower air pressure.

Over 1500 metres, you may need to adjust the fuel injection to obtain correct combustion. Contact our Technical Service department for further information. To reduce problems due to lower air pressure, it is also advisable to clean the air filter more frequently. Keep an eye on the engine temperature as it tends to overheat.

3.9 LENGTHY STORAGE**WARNING**

WHEN STORING THE ENGINE, PROCEED AS EXPLAINED IN THE ENGINE MANUAL.

THE AREA IN WHICH THE MACHINE IS STORED, IF ENCLOSED, MUST BE WELL VENTILATED TO PREVENT RUSTING.

When storing the machine for a long period of time, proceed as follows:

- Clean the machine and store it under cover. If it is to be stored outdoors, place it on a flat surface and cover it.
- Apply grease to all exposed parts of the cylinder pistons
- Completely drain the fuel circuit.

During the storage period, start the machine up at least once a month to maintain the film of lubricating oil

End of storage:

- clean the grease off the cylinder pistons
- make sure the fuel and lubricant tanks are full.

4 TROUBLESHOOTING

4.1 PROBLEMS AND SOLUTIONS

Take note of any abnormal behaviour of the machine during daily operation. For every abnormality, try to identify the cause and take prompt action to correct it. If you neglect such behaviour, it may lead to greater problems down the line.

PROBLEM	PROBABLE CAUSE	SOLUTION
Control lever hard to operate, or does not return automatically	<ul style="list-style-type: none"> Control valve inefficient. 	<ul style="list-style-type: none"> Contact service centre.
No movements possible, power lacking	<ul style="list-style-type: none"> Insufficient hydraulic fluid. Hydraulic fluid filter blocked. Engine power low. Fault in pump or coupling. Regulation valve pressure low. Control valve faulty. 	<ul style="list-style-type: none"> Fill to level. Service fluid filter. Service air filter and check fuel supply. Contact service centre. Contact service centre. Contact service centre.
No drive on one or the other side.	<ul style="list-style-type: none"> Foreign body - like a stone - jammed in mechanism. Bad operation of drive motor. 	<ul style="list-style-type: none"> Remove jammed matter. Contact service centre.
Machine does not drive in a straight line.	<ul style="list-style-type: none"> Something jammed. Unequal track tension. Pump malfunction Drive lever malfunction. Drive engine fault. 	<ul style="list-style-type: none"> Remove foreign matter. Adjust tension on both sides. Contact service centre. Contact service centre. Contact service centre.
No bucket lift power	<ul style="list-style-type: none"> Lack of hydraulic fluid. Regulator valve pressure low. Control valve damaged. Hydraulic cylinder faulty. 	<ul style="list-style-type: none"> Fill to level. Contact service centre. Contact service centre. Contact service centre.

4.2 SPARE PARTS



WARNING

- REPLACE WORN AND DAMAGED PARTS WITH ORIGINAL KATO IMER SPARE PARTS.
- USING NON-ORIGINAL SPARE PARTS CAN CAUSE DAMAGE AND INJURY.
- KATO IMER IS NOT LIABLE FOR DAMAGE CAUSED BY THE USE OF NON-ORIGINAL SPARE PARTS, UNLESS EXPRESSLY AUTHORISED.



WARNING

- IT IS FORBIDDEN TO MAKE CHANGES OF ANY SORT TO THE STRUCTURE AND THE PLANT DESIGN OF THE MACHINE BECAUSE THIS MAY COMPROMISE ITS SAFE USE.

5 HYDRAULIC CIRCUIT DIAGRAM

5.1 TECHNICAL DATA

REF.	DESCRIPTION	PRESSURE	
		Mpa	Kgf/cm ²
MR1	Max. pressure valve, main pump P1	13,7	140

Hydraulic oil reservoir capacity 10 litres
 Hydraulic circuit capacity 12 litres
 Flow rate (version with double pump)
 P1-P2: 2x10 litres/min
 Flow rate (version with triple pump)
 P1: 7,5 litres/min P2-P3: 2x10 litres/min

5.2 HYDRAULIC CIRCUIT DIAGRAM

The 2 2-element control valves are used:

- On the basic version, fixed undercarriage, with the skip or loading platform and with the option of mounting the self-loading bucket or other accessories.

MACHINE WITH DOUBLE PUMP

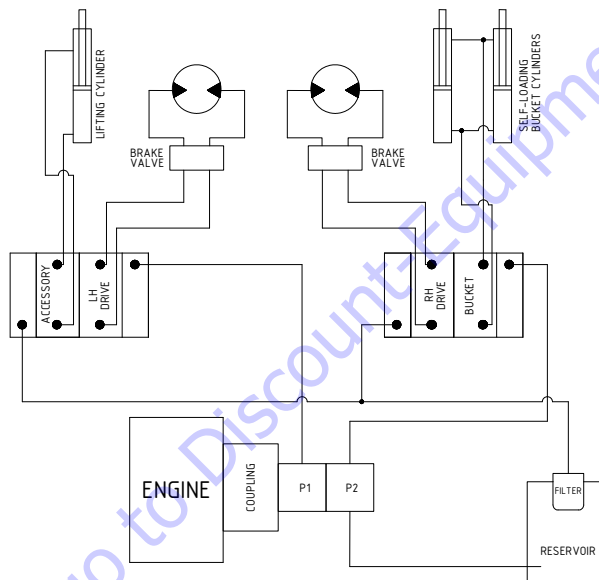

MACHINE WITH TRIPLE PUMP

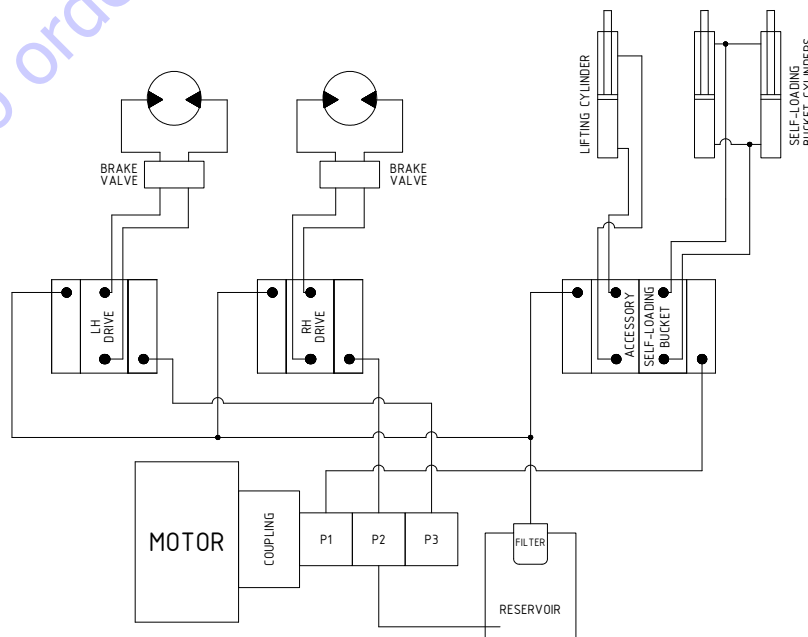

6 TECHNICAL SPECIFICATIONS

6.1 GENERAL SPECIFICATIONS

GENERAL PERFORMANCE RATINGS

Travel speed	<i>kph</i>	2,5
Max. slope	% (<i>° slope</i>)	34% (20°)
Max. slope with load	% (<i>° slope</i>)	20% (11°)
Load capacity	<i>Kg</i>	500
Operating temperature range	°C	-20 / +46

WEIGHT

<i>Weight of machine</i>	<i>Kg</i>
Basic petrol	240
Skip / skip with self-loading bucket	50 / 105
Loading platform	65

The **weight of the machine** is determined by the weight of the basic machine plus that of the accessory mounted to it.

DRIVE

PETROL ENGINE	Honda GX 200	4.7 kW / 6.5 hp	3600 rpm
---------------	---------------------	-----------------	----------

NOISE LEVEL OF PETROL AND DIESEL ENGINES

		<i>Petrol</i>
Guaranteed level of sound power	LwA	98 dB
Sound pressure level at operator's ear	LpA	83 dB

6.2 DIMENSIONS OF MACHINE

DIMENSIONS

Description	Rubber tracks	
	mm	
Track width	mm	180
Track length	mm	1120
Machine width	mm	690
Height at controls	mm	1132
Minimum ground clearance	mm	80
Skip: Volume	m ³	0,22
Loading platform (Optional): Dimensions	Sides closed [L X W X H]	mm 900x620x200
	Sides open [L X W]	mm 1120x1150

6.3 MACHINE DIMENSIONS AND OPERATING LIMITS

SKIP + SELF-LOADING BUCKET

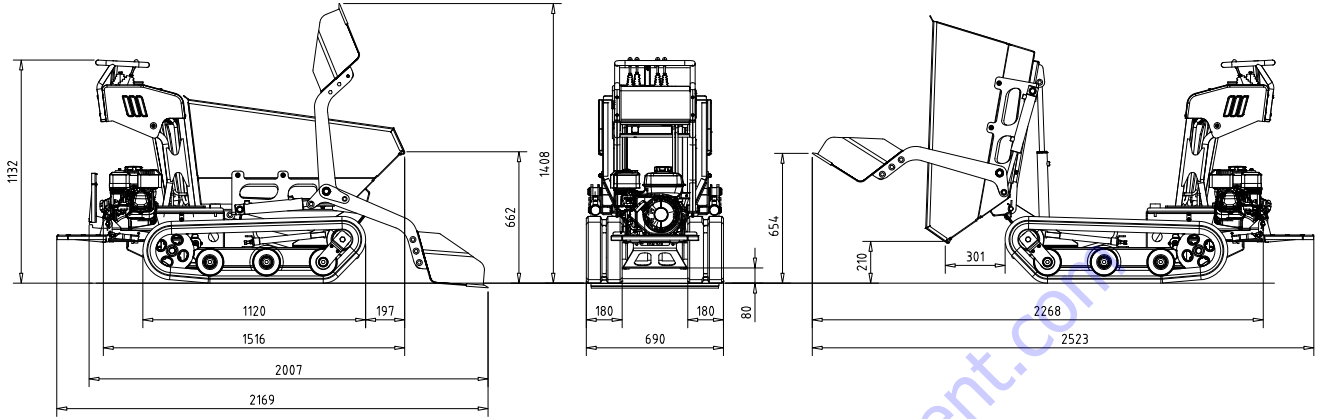

LOADING PLATFORM

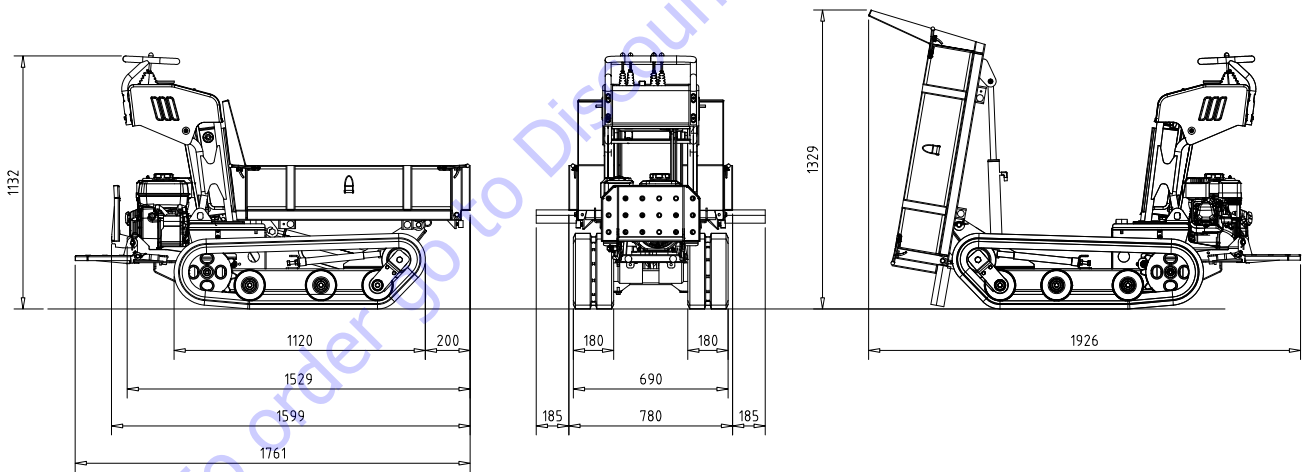

TO PURCHASE THIS PRODUCT PLEASE CONTACT US



**Equipment Financing and
Extended Warranties Available**



**Discount-Equipment.com is your online resource for
commercial and industrial quality parts and equipment sales.**

561-964-4949

visit us on line @ www.discount-equipment.com

Select an option below to find your Equipment

Search by Manufacturer

Search by Product Type

Request a Quote

We sell worldwide for the brands: Genie, Terex, JLG, MultiQuip, Mikasa, Essick, Whiteman, Mayco, Toro Stone, Diamond Products, Generac Magnum, Airman, Haulotte, Barreto, Power Blanket, Nifty Lift, Atlas Copco, Chicago Pneumatic, Allmand, Miller Curber, Skyjack, Lull, Skytrak, Tsurumi, Husquvarna Target, Stow, Wacker, Sakai, Mi-T-M, Sullair, Basic, Dynapac, MBW, Weber, Bartell, Bennar Newman, Haulotte, Ditch Runner, Menegotti, Morrison, Contec, Buddy, Crown, Edco, Wyco, Bomag, Laymor, EZ Trench, Bil-Jax, F.S. Curtis, Gehl Pavers, Heli, Honda, ICS/PowerGrit, IHI, Partner, Imer, Clipper, MMD, Koshin, Rice, CH&E, General Equipment, Amida, Coleman, NAC, Gradall, Square Shooter, Kent, Stanley, Tamco, Toku, Hatz, Kohler, Robin, Wisconsin, Northrock, Oztec, Toker TK, Rol-Air, APT, Wylie, Ingersoll Rand / Doosan, Innovatech, Con X, Ammann, Mecalac, Makinex, Smith Surface Prep, Small Line, Wanco, Yanmar



www.Discount-Equipment.com

TRACKED MINIDUMPER

CARRY 105

PUBLISHED: MARCH 2017

KATO IMER S.p.A.

ITALY