

REVISED STARTING  
SERIAL # 120210262

## PARTS LIST MANUAL 48" CORE DRILL RIGS



SKU #	MODEL #	VACUUM PUMP	DRILL MOTOR	SPEED/RPM
97100EV	4820	INCLUDED	MILWAUKEE DYMO DRILL	2 SPEED
97100E	4820	NOT INCLUDED	20 AMP, 120 VOLT, 60 HZ	300/600



A Division of Equipment Development Company, Inc.



Printed in USA  
JWA ©2012

# PARTS FINDER

**Search Website  
by Part Number**



**Search Manual  
Library For Parts  
Manual & Lookup Part  
Numbers – Purchase  
or Request Quote**

**Search Manuals**

Enter your information to help us find the right parts manual for your machine.

\* Brand:

\* Model:

\* Serial:

\* Part Number:

SEARCH

**Can't Find Part or  
Manual? Request Help  
by Manufacturer,  
Model & Description**

**Parts Order Form**

Please fill in the following information to help us find the right part for your machine.

Manufacturer:	<input type="text"/>
Model:	<input type="text"/>
Description:	<input type="text"/>
Part Number:	<input type="text"/>
Quantity:	<input type="text"/>
Notes:	<input type="text"/>

Submit

Discount-Equipment.com is your online resource for quality parts & equipment.

Florida: **561-964-4949** Outside Florida TOLL FREE: **877-690-3101**

**Need parts?**

Click on this link: <http://www.discount-equipment.com/category/5443-parts/> and choose one of the options to help get the right parts and equipment you are looking for. Please have the machine model and serial number available in order to help us get you the correct parts. If you don't find the part on the website or on one of the online manuals, please fill out the request form and one of our experienced staff members will get back to you with a quote for the right part that your machine needs.

We sell worldwide for the brands: Genie, Terex, JLG, MultiQuip, Mikasa, Essick, Whiteman, Mayco, Toro Stone, Diamond Products, Generac Magnum, Airman, Haulotte, Barreto, Power Blanket, Nifty Lift, Atlas Copco, Chicago Pneumatic, Allmand, Miller Curber, Skyjack, Lull, Skytrak, Tsurumi, Husquvarna Target, Stow, Wacker, Sakai, Mi-T-M, Sullair, Basic, Dynapac, MBW, Weber, Bartell, Bennar Newman, Haulotte, Ditch Runner, Menegotti, Morrison, Contec, Buddy, Crown, Edco, Wyco, Bomag, Laymor, EZ Trench, Bil-Jax, F.S. Curtis, Gehl Pavers, Heli, Honda, ICS/PowerGrit, IHI, Partner, Imer, Clipper, MMD, Koshin, Rice, CH&E, General Equipment, Amida, Coleman, NAC, Gradall, Square Shooter, Kent, Stanley, Tamco, Toku, Hatz, Kohler, Robin, Wisconsin, Northrock, Oztec, Toker TK, Rol-Air, APT, Wylie, Ingersoll Rand / Doosan, Innovatech, Con X, Ammann, Mecalac, Makinex, Smith Surface Prep, Small Line, Wanco, Yanmar

## READ AND UNDERSTAND THE OPERATORS INSTRUCTION MANUAL *THOROUGHLY* BEFORE ATTEMPTING TO OPERATE THIS EQUIPMENT.



Death or serious injury could occur if this machine is used improperly.



### SAFETY MESSAGES

- Safety Instructions are preceded by a graphic alert symbol of DANGER, WARNING, or CAUTION.

#### DANGER

Indicates an imminent hazard which, if not avoided, will result in death or serious injury.

#### WARNING

Indicates an imminent hazard which, if not avoided, can result in death or serious injury.

#### CAUTION

Indicates hazards which, if not avoided, could result in serious injury and or damage to the equipment.

### GASOLINE/PROPANE POWERED EQUIPMENT

#### WARNING

- Engine exhaust from this product contains chemicals known to the State of California to cause cancer, birth defects or other reproductive harm.



Gasoline is extremely flammable and poisonous. It should only be dispensed in well ventilated areas, and with a cool engine.

- Small gasoline engines produce high concentrations of carbon monoxide (CO) example: a 5 HP 4 cycle engine operation in an enclosed 100,000 cu. ft. area with only one change of air per hour is capable of providing deadly concentrations of CO in less than fifteen minutes. Five changes of air in the same area will produce noxious fumes in less than 30 minutes. Gasoline or propane powered equipment should not be used in enclosed or partially enclosed areas. Symptoms of CO poisoning include, headache, nausea, weakness, dizziness, visual problems and loss of consciousness. If symptoms occur - get into fresh air and seek medical attention immediately.

### ELECTRICAL POWERED EQUIPMENT



Extreme care must be taken when operating electric models with water present: Ensure power cord is properly grounded, is attached to a Ground-Fault-Interrupter (GFI) outlet, and is undamaged.

- Check all electrical cables - be sure connections are tight and cable is continuous and in good condition. Be sure cable is correctly rated for both the operating current and voltage of this equipment.
- Improper connection of the equipment-grounding conductor can result in a risk of electric shock. Check with qualified electrician or service person if there is any doubt as to whether the outlet is properly grounded. Adhere to **all** local codes and ordinances.
- **NOTE:** In the event of a malfunction or breakdown, grounding provides a path of least resistance for the electric current to dissipate. The motor is equipped with a grounded plug and must be connected to an outlet that is properly installed and properly grounded. DO NOT modify the plug provided on the motor. If the plug does not fit the outlet have a qualified electrician install the proper receptacle.
- Switch motor OFF **before** disconnecting power.

- Do not disconnect power by pulling cord. To disconnect, grasp the plug, not the cord.
- Unplug power cord at the machine when not in use and before servicing.

### GENERAL INSTRUCTIONS

- Equipment should only be operated by trained personnel in good physical condition and mental health (not fatigued). The operator and maintenance personnel must be physically able to handle the bulk weight and power of this equipment.
- This is a one person tool. Maintain a safe operating distance to other personnel. It is the **operators' responsibility** to keep other people (workers, pedestrians, bystanders, etc.) away during operation. Block off the work area in all directions with roping, safety netting, etc. for a safe distance. Failure to do so may result in others being injured by flying debris or exposing them to harmful dust and noise.
- This equipment is intended for commercial use only.
- For the operator's safety and the safety of others, always keep all guards in place during operation.
- Never let equipment run unattended.



- Personal Protection Equipment and proper safety attire must be worn when operating this machinery. The operator must wear approved safety equipment appropriate for the job such as hard hat and safety shoes when conditions require. Hearing protection **MUST** be used (operational noise levels of this equipment may exceed 90db). Eye protection **MUST** be worn at all times.



Keep body parts and loose clothing away from moving parts. Failure to do so could result in dismemberment or death.

- Do not modify the machine.
- Stop motor/engine when adjusting or servicing this equipment.



Maintain a safe operating distance from flammable materials. Sparks from the cutting-action of this machine can ignite flammable materials or vapors.

### DUST WARNING

#### WARNING

Some dust created by power sanding, sawing, grinding, drilling, and other construction activities contains chemicals known to cause cancer, birth defects, or other reproductive harm. Some examples of these chemicals are:

- Lead from lead-based paints, and
- Crystalline silica from bricks and concrete and other masonry products.

Your risk of exposure to these chemicals varies depending on how often you do this type of work. To reduce your risk: work in a well ventilated area, use a dust control system, such as an industrial-style vacuum, and wear approved personal safety equipment, such as a dust/particle respirator designed to filter out microscopic particles.

# PARTS LIST MANUAL

## 48" CORE DRILL RIGS

### TABLE OF CONTENTS

<u>Section</u>	<u>Page Number</u>
Safety Messages and General Instructions .....	2
How To Order Replacement Parts .....	3
Illustration 1: Base and Column Grouping .....	4, 5
Illustration 2: Vacuum Pump Assembly .....	6, 7
Illustration 3: Carriage Assembly .....	8, 9
Illustration 4: Drill Motor Grouping .....	10, 11
Illustration 5: Motor Mount Kit for 14" Drill Bit .....	12
Illustration 6: Motor Mount Kit for 16" Drill Bit .....	13
Illustration 7: Control Box Assembly .....	14
Illustration 8: Wiring Diagram for Control Box .....	15
Limited Equipment Warranty of Sale - Terms & Conditions .....	16 (Back Page)



A Division of Equipment Development Company, Inc.

ILLUSTRATION 1: BASE AND COLUMN GROUPING

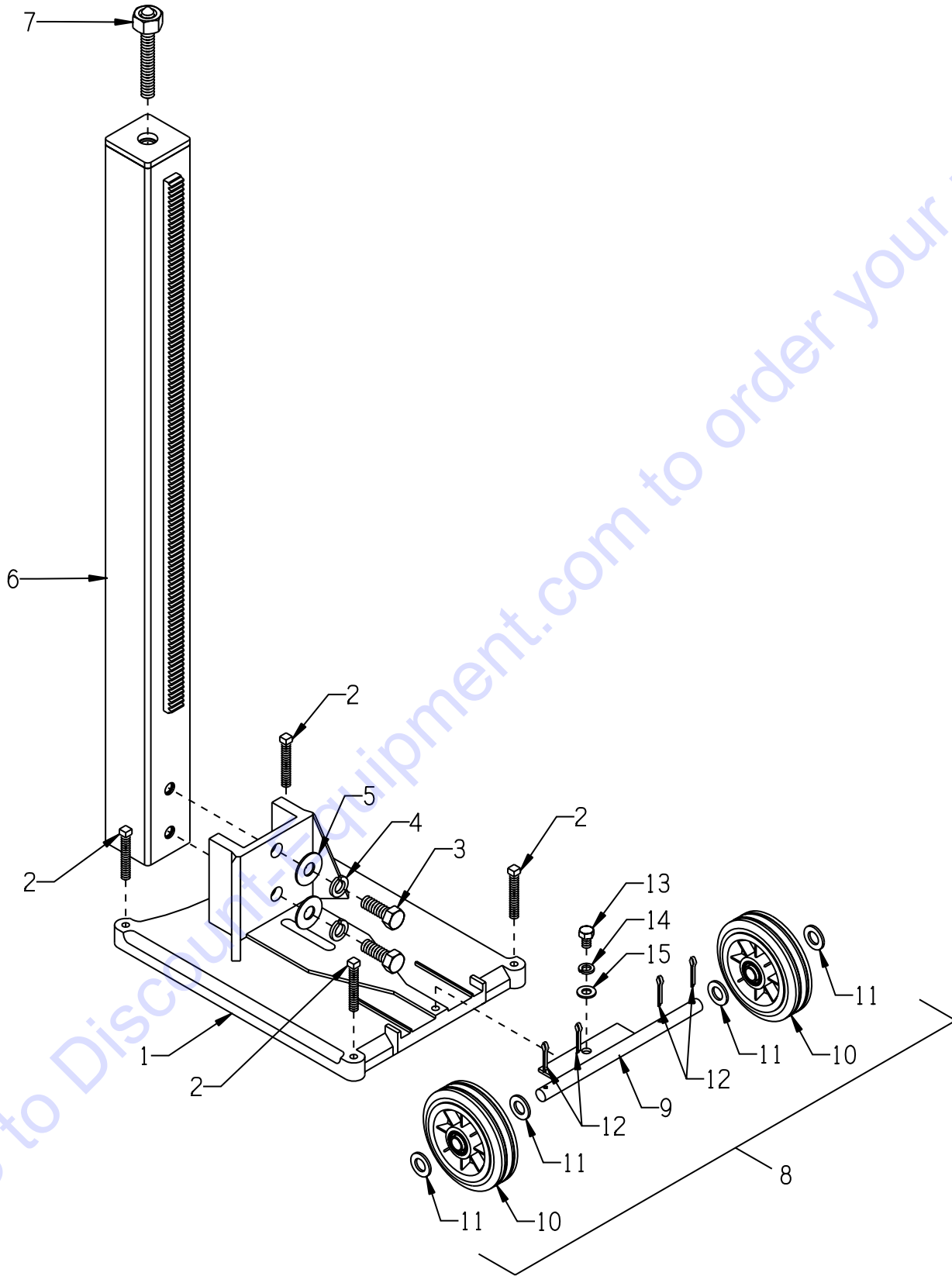

**PARTS LISTING - ILLUSTRATION 1 : BASE AND COLUMN GROUPING**

ITEM #	PART #	DESCRIPTION	QTY.
1	97003	VACUUM BASE, DRILL RIG	1
2	97017	SCREW, SET 1/2-13 X 3 SQ. HD	4
3	97020	SCREW, CAP 3/4-10 X 2	2
4	10489	WASHER, LOCK 3/4 ZINC	2
5	97021	WASHER, FLAT 3/4 USS	2
6	97044	MAST, 48" FOR LARGE DRILL RIG (COLUMN)	1
7	97050	CEILING JACK, DRILL RIG	1
8	97054K	WHEEL BASE ASSEMBLY (INCLUDES ITEMS 9 THRU 12)	1
9	97054	WHEEL BASE PLATE	1
10	80028	WHEEL 6 X 2 X 3/4" BRG.	2
11	10009	WASHER, FLAT 3/4 SAE ZINC	4
12	10306	PIN, COTTER 3/16 X 1-1/2	4
13	10914	SCREW, CAP 1/2-13 X 1	1
14	10045	WASHER, LOCK 1/2 ZINC	1
15	10312	WASHER, FLAT 1/2 SAE ZINC	1



A Division of Equipment Development Company, Inc.

ILLUSTRATION 2 : VACUUM PUMP ASSEMBLY

PART # 97043

NOTE: THE VACUUM PUMP IS NOT INCLUDED ON ALL MODELS

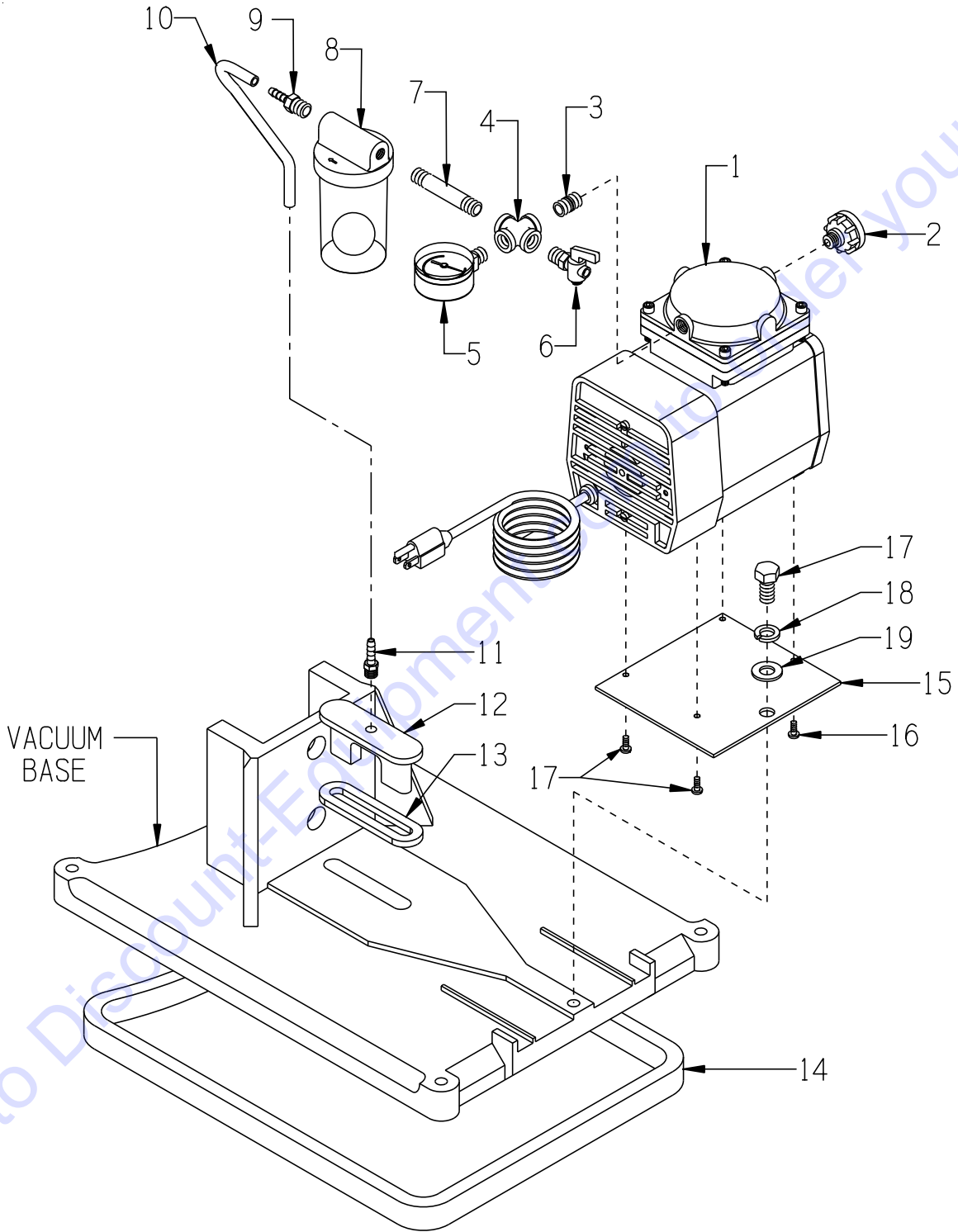

NOTE: THE VACUUM PUMP IS NOT INCLUDED ON ALL MODELS

<b>PARTS LISTING - ILLUSTRATION 2 : VACUUM PUMP ASSEMBLY</b>			
<b>ITEM #</b>	<b>PART #</b>	<b>DESCRIPTION</b>	<b>QTY.</b>
1-19	97043	VACUUM PUMP ASSEMBLY (INCLUDES ITEMS 1 THRU 19)	1
1	97027	COMPRESSOR, 115V, 4.2A, 60HZ, 60PSI	1
2	97036	MUFFLER, SCREW IN, 1/4 NPT	1
3	97032	NIPPLE, CLOSE, 1/4"NPT (BRASS)	1
4	97031	CROSS, 1/4" NPT (BRASS)	1
5	97030	GAUGE, PRESSURE/VACUUM, DRILL RIG	1
6	97029	VALVE, SHUT OFF, 1/4"NPT, 150PSI	1
7	97033	PIPE NIPPLE, 1/4NPT X 3"L (BRASS)	1
8	97028	WATER SEPARATOR	1
9	97034	BARB, 1/4HOSE X 1/4MPT (BRASS)	1
10	97055	HOSE 1/4"ID X 3/8"OD X 9"L (CLEAR)	1
11	10708	BARB, 1/4HOSE X 1/8MPT (BRASS)	1
12	97008	ANCHOR SLOT INSERT, DRILL RIG	1
13	97038	GASKET, ANCHOR SLOT	1
14	97037	GASKET, BASE	1
15	97046	MOUNT PLATE, VACUUM PUMP	1
16	10830	SCREW, MACHINE 10-32 X 1/2	4
17	10914	SCREW, CAP 1/2-13 X 1	1
18	10045	WASHER, LOCK 1/2 ZINC	1
19	10312	WASHER, FLAT 1/2 SAE ZINC	1



A Division of Equipment Development Company, Inc.



ILLUSTRATION 3 : CARRIAGE ASSEMBLY

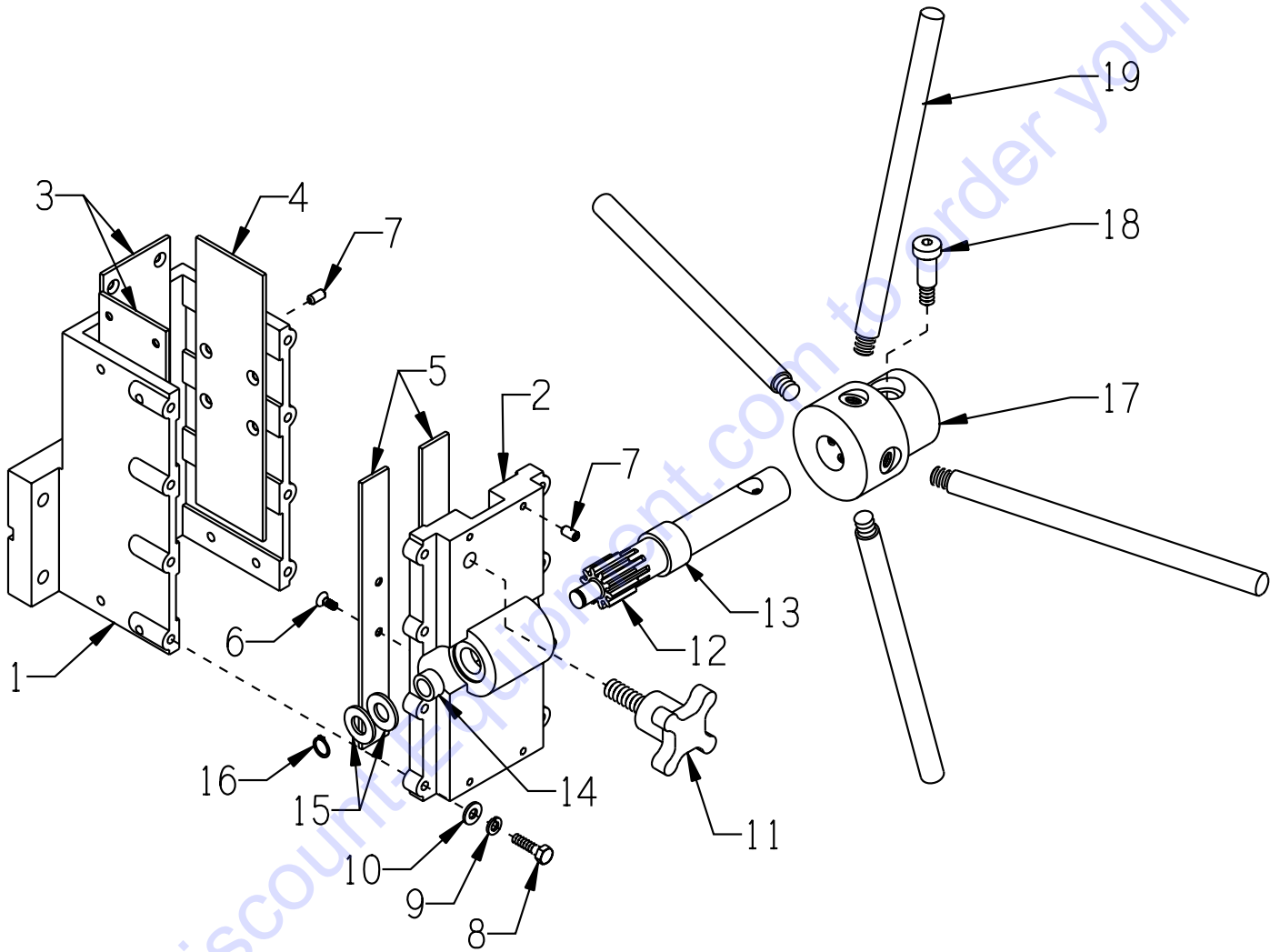

**PARTS LISTING - ILLUSTRATION 3 : CARRIAGE ASSEMBLY**

ITEM #	PART #	DESCRIPTION	QTY.
1-16	97004A	CARRIAGE ASSEMBLY LESS HANDLE (INCLUDES ITEMS 1 THRU 16)	1
1	97004	CARRIAGE	1
2	97005	CARRIAGE COVER	1
3	97047	WEAR STRIP 2.5 X 8.625 (4 HOLES IN CORNERS)	2
4	97048	WEAR STRIP 2.5 X 8.625 (4 HOLES IN CENTER)	1
5	97049	WEAR STRIP 1.0 X 8.625 (2 HOLES IN CENTER)	2
6	97016	SCREW, FLAT HD MACHINE 10-32 X 1/2 BRASS	16
7	10162	SCREW, SET 1/4-20 X 1/2"	8
8	10031	SCREW, CAP 1/4-20 X 1	8
9	10038	WASHER, LOCK 1/4 ZINC	8
10	10602	WASHER, FLAT 1/4 SAE ZINC	8
11	97025	HANDLE, ALUMINUM 1/2-13 X 1 1/2	1
12	97010	PINION GEAR	1
13	97023	SPACER, BRASS 1 1/4 OD X 1"ID X 3/4	1
14	97024	SPACER, BRASS 3/4OD X 1/2"ID X 3/8	1
15	10312	WASHER, FLAT 1/2 SAE ZINC	2
16	97014	RETAINING RING, EXT. 1/2"	1
17	97052	HANDLE YOKE	1
18	97026	SCREW, SKT.SHOULDER 5/8 X 1, 1/2-13	1
19	97045	HANDLE, 10"	4



A Division of Equipment Development Company, Inc.

ILLUSTRATION 4 : DRILL MOTOR GROUPING

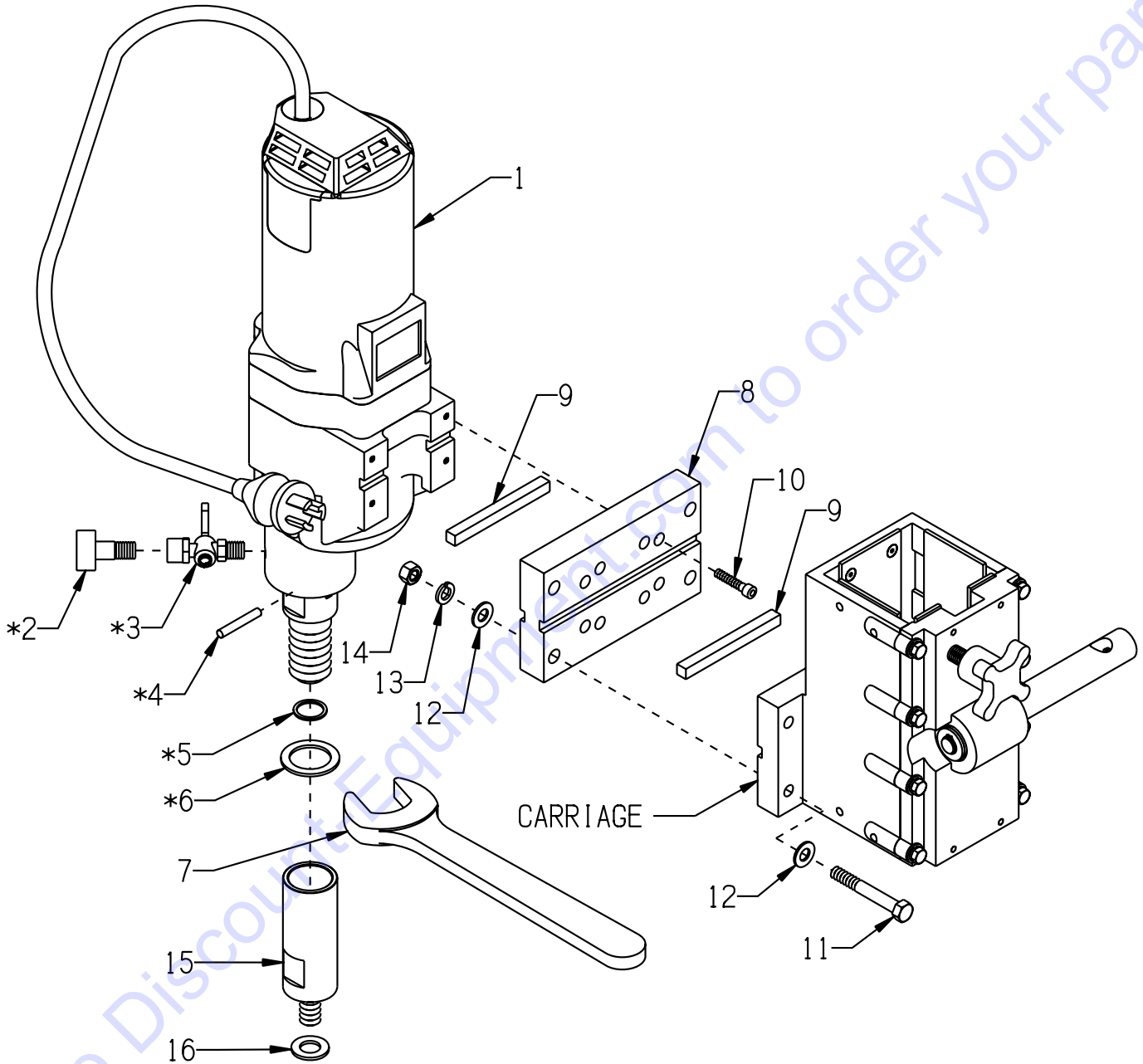

PARTS LISTING - ILLUSTRATION 4: DRILL MOTOR GROUPING			
ITEM #	PART #	DESCRIPTION	QTY.
1	97001	DRILL MOTOR (INCLUDES ITEMS ITEMS 1 THRU 7) MILWAUKEE #4079, 20 AMP, 2 SPEED, SHEAR PIN	1
*2	97065	ADAPTER 3/4SFGH X 1/4MPT	1
*3	97064	SHUT OFF VALVE 45-80-0060	1
*4	97062	PIN, SHEAR 44-60-0032	6
*5	97068	RETAINING RING 34-60-1800	1
*6	97059	WASHER, SS 1-1/4 X 1-3/4 X 3/32	2
7	97069	WRENCH 49-96-4700 (INCLUDED W/ DRILL MOTOR)	1
8	97053	MOTOR MOUNT SPACER BLOCK	1
9	97051	KEY 3/8"SQ X 4"L	2
10	97015	SCREW, SKT. HD. CAP 1/4-20 X 1-1/4	4
11	97012	SCREW, CAP 3/8-16 X 2-3/4	4
12	10025	WASHER, FLAT 3/8 SAE ZINC	8
13	10811	WASHER, LOCK 3/8 ZINC	4
14	10810	NUT, HEX LOCK 3/8-16 ZINC	4
15	97072	ADAPTER 1 1/4-7 TO 5/8-11 (OPTIONAL FOR SMALL BITS)	1
16	10073	WASHER, FLAT 5/8 SAE ZINC (OPTIONAL)	1
* THESE ITEMS ARE INCLUDED WITH THE DRILL MOTOR IN A SEPARATE ACCESSORY BAG			



A Division of Equipment Development Company, Inc.

ILLUSTRATION 5: MOTOR MOUNT KIT FOR 14" DRILL BIT

OPTIONAL - PART # 97060K

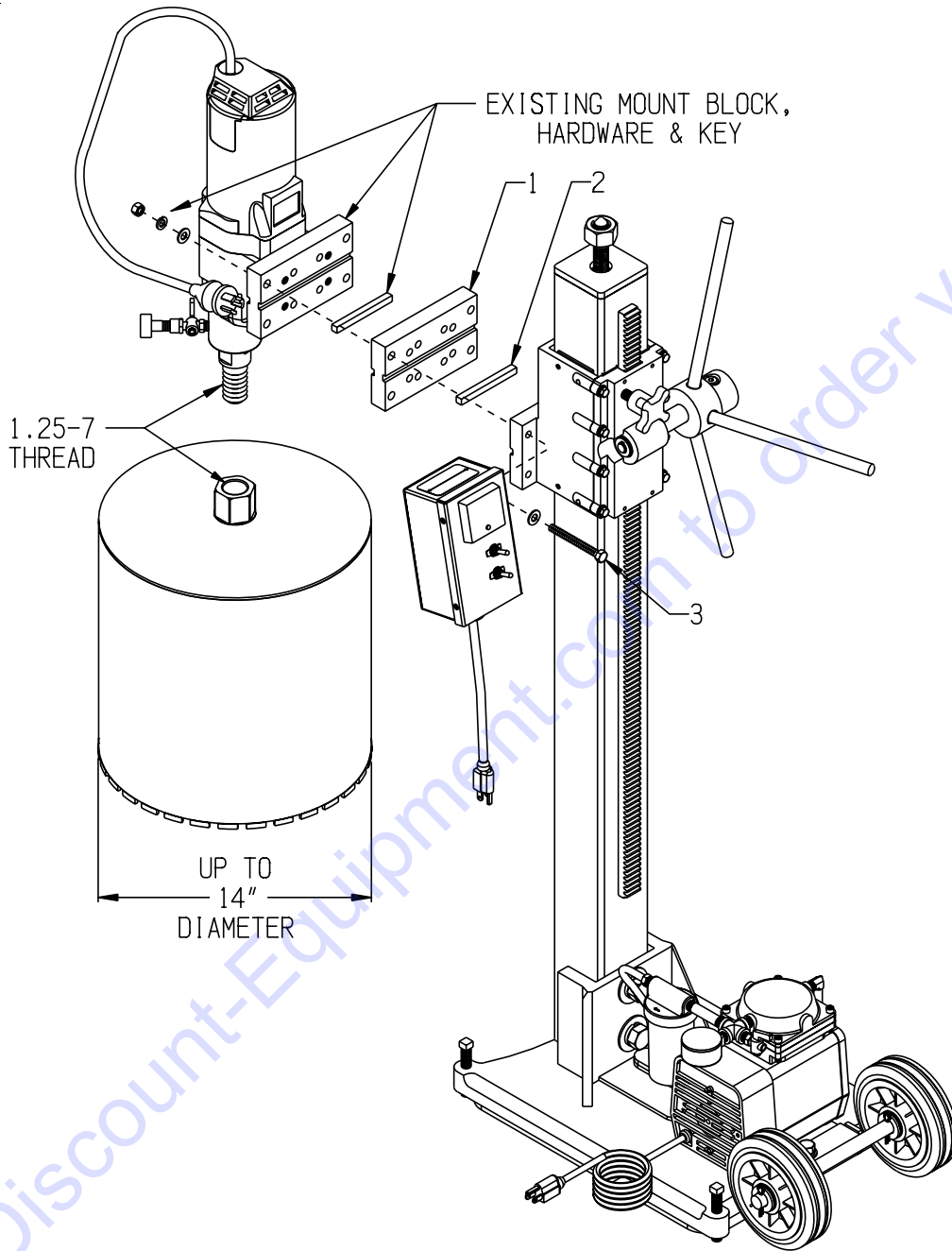

ITEM #	PART #	DESCRIPTION	QTY.
1	97053	MOTOR MOUNT SPACER BLOCK	1
2	97051	KEY 3/8"SQ X 4"L	1
3	10868	SCREW, CAP 3/8-16 X 3-1/2	4

**ILLUSTRATION 6: MOTOR MOUNT KIT FOR 16" DRILL BIT**

**OPTIONAL - PART # 97061K**

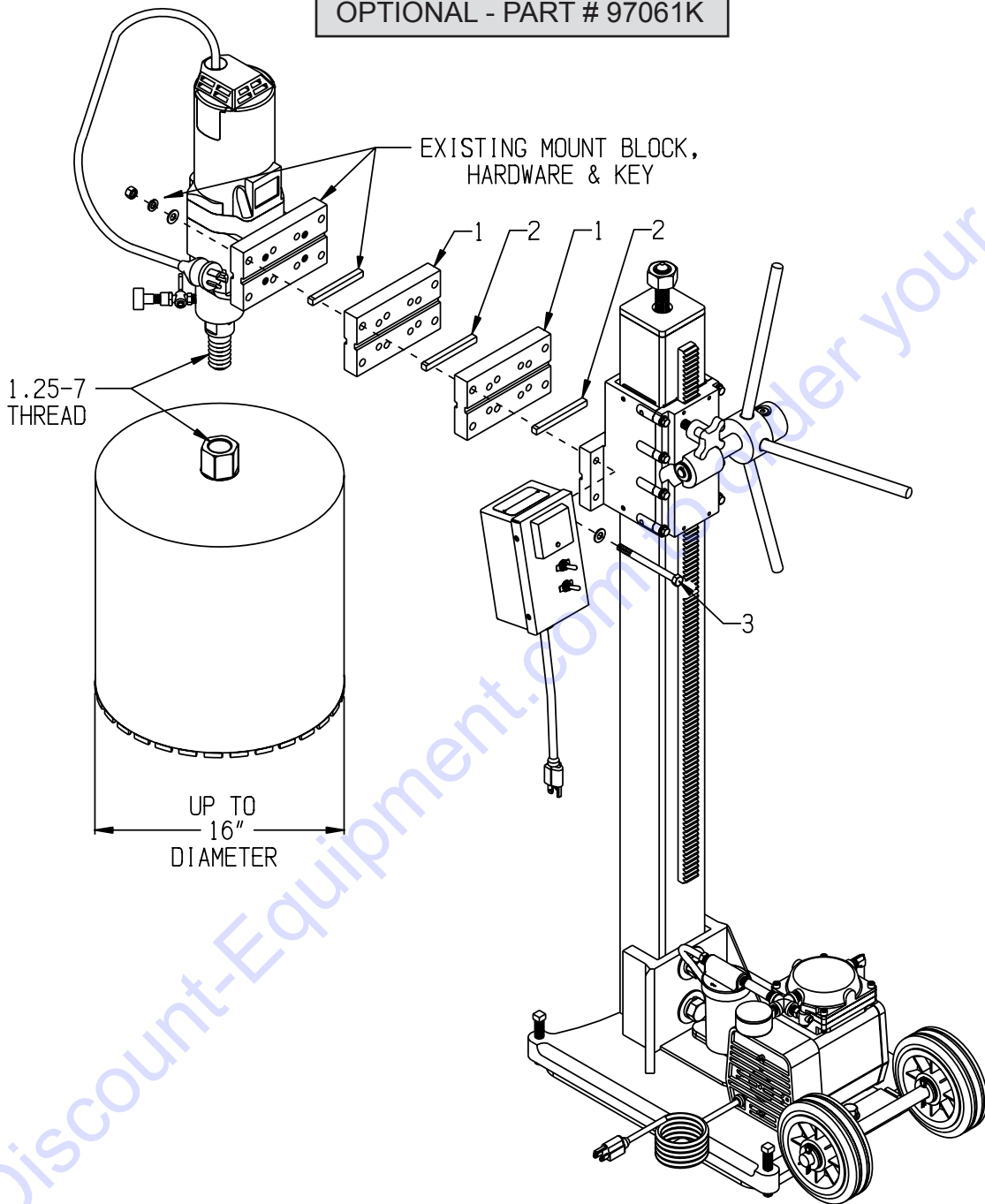

ITEM #	PART #	DESCRIPTION	QTY.
1	97053	MOTOR MOUNT SPACER BLOCK	2
2	97051	KEY 3/8"SQ X 4"L	2
3	10349	SCREW, CAP 3/8-16 X 4-1/2	4

## ILLUSTRATION 7: CONTROL BOX ASSEMBLY

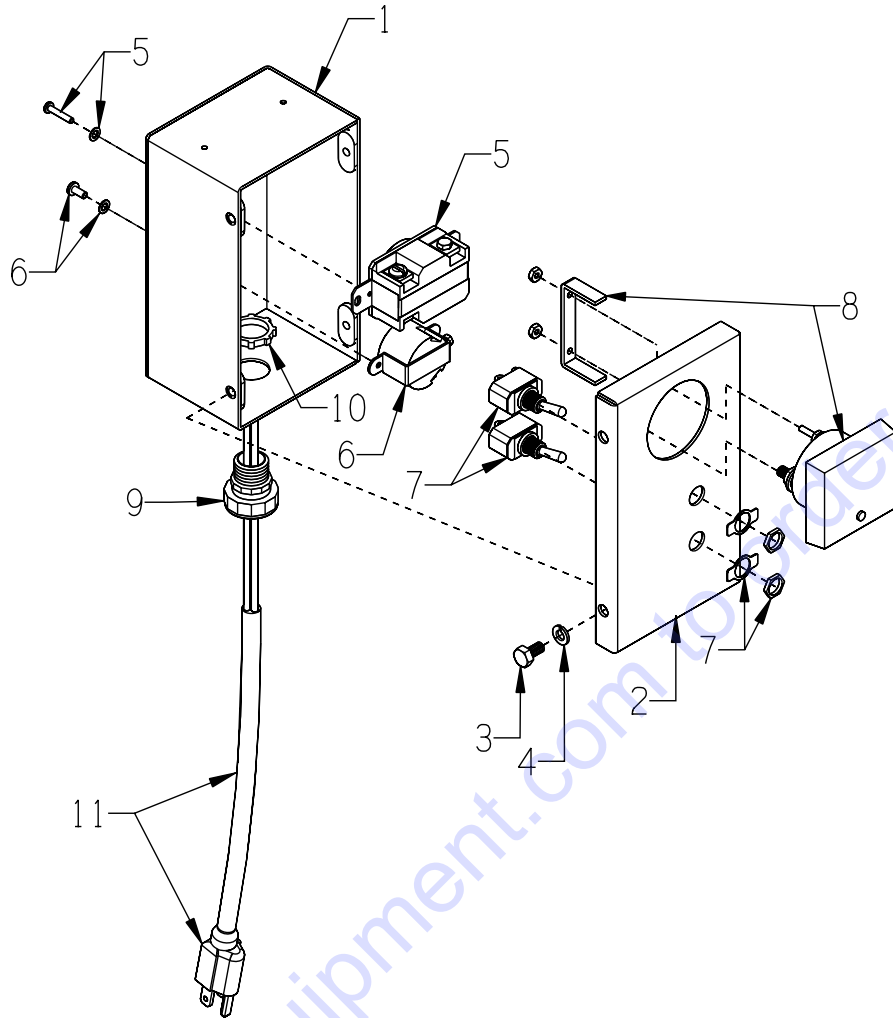

ITEM #	PART #	DESCRIPTION	QTY.
1-11	97006A	CONTROL BOX COMPLETE (INCLUDES ITEMS 1 THRU 11)	1
1	97006	CONTROL BOX ONLY, DRILL RIG	1
2	97007	CONTROL BOX COVER, DRILL RIG	1
3	10834	SCREW, CAP 1/4-20 X 1/2 ZINC	4
4	10038	WASHER, LOCK 1/4 ZINC	4
5	16198	RECEPTACLE, LOCKING 20A-125V L520R	1
6	16199	RECEPTACLE, SINGLE 15A-125V 5258	1
7	16189	SWITCH, TOGGLE SPST 20/10A-125/250V	2
8	97009	AMMETER, 2 1/2" ROUND, 0-30AC AMPS	1
9	41130	STRAIN RELIEF 1/2NPT X .550-.650"	1
10	10790	CONDUIT LOCK NUT 1/2 NP	1
11	97057	PLUG, MOLDED, 12/3 CORD	1

**ILLUSTRATION 8:  
WIRING DIAGRAM FOR CONTROL BOX**

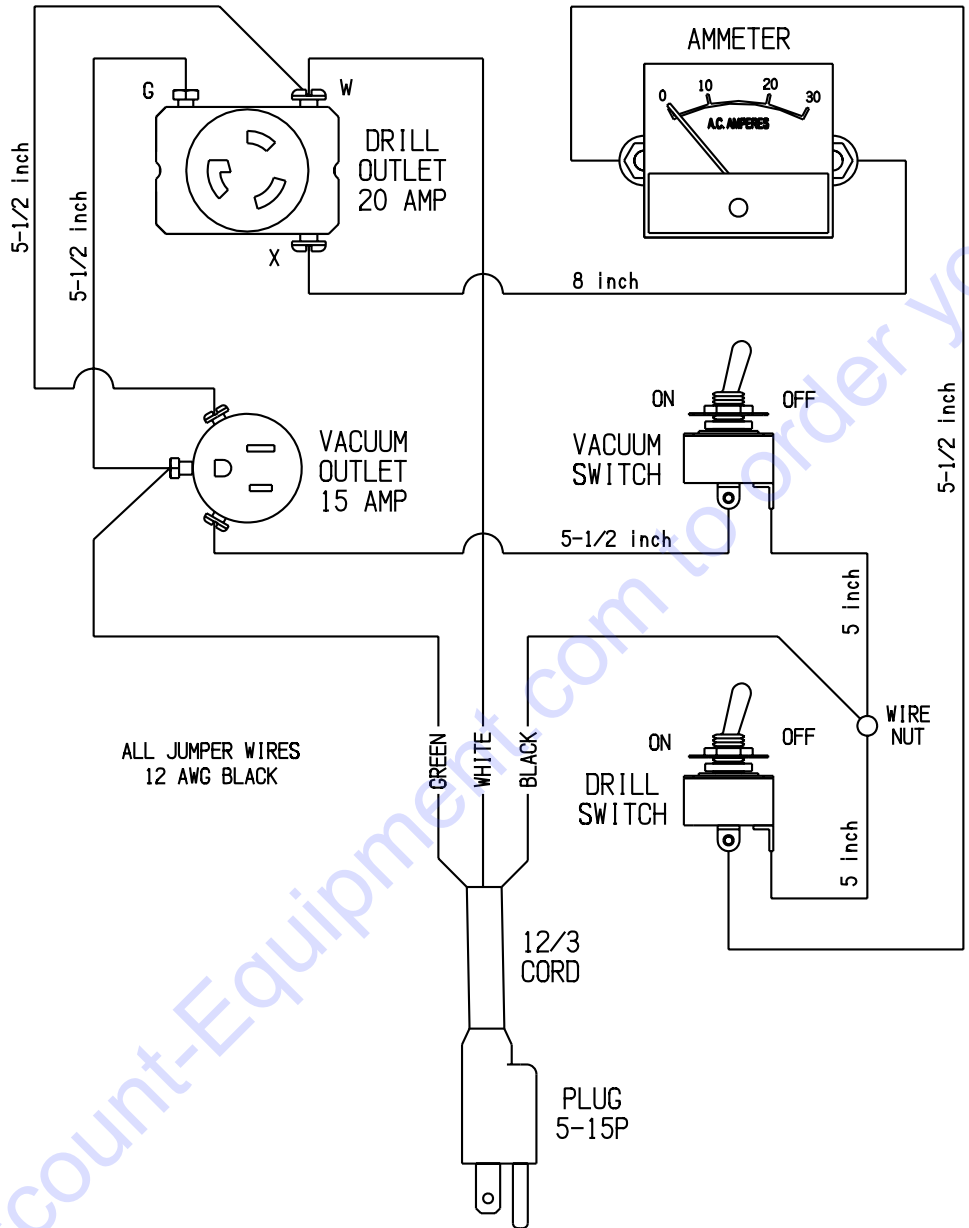

PARTS LISTING FOR WIRE AND TERMINALS REQUIRED		
PART #	DESCRIPTION	QTY.
99017	WIRE, ELEC. 12 AWG BLACK STRANDED	36" TOTAL
11715	TERM., FEM. PUSH-ON 12-10GA.	4
10967	TERM., FLANGED SPADE #10 12-10GA.	4
10968	TERM., RING 5/16 16-14GA. INSULATED	2
10966	CONNECTOR, WIRE NUT (YELLOW)	1



# PARTS FINDER

**Search Website  
by Part Number**



**Search Manual  
Library For Parts  
Manual & Lookup Part  
Numbers – Purchase  
or Request Quote**

**Search Manuals**

Enter your information to help us find the right parts manual for your machine.

\* Brand:

\* Model:

\* Serial:

\* Part Number:

SEARCH

**Can't Find Part or  
Manual? Request Help  
by Manufacturer,  
Model & Description**

**Parts Order Form**

Please fill in the following information to help us find the right part for your machine.

Manufacturer:	<input type="text"/>
Model:	<input type="text"/>
Description:	<input type="text"/>
Part Number:	<input type="text"/>
Quantity:	<input type="text"/>
Notes:	<input type="text"/>

Submit

Discount-Equipment.com is your online resource for quality parts & equipment.

Florida: **561-964-4949** Outside Florida TOLL FREE: **877-690-3101**

**Need parts?**

Click on this link: <http://www.discount-equipment.com/category/5443-parts/> and choose one of the options to help get the right parts and equipment you are looking for. Please have the machine model and serial number available in order to help us get you the correct parts. If you don't find the part on the website or on one of the online manuals, please fill out the request form and one of our experienced staff members will get back to you with a quote for the right part that your machine needs.

We sell worldwide for the brands: Genie, Terex, JLG, MultiQuip, Mikasa, Essick, Whiteman, Mayco, Toro Stone, Diamond Products, Generac Magnum, Airman, Haulotte, Barreto, Power Blanket, Nifty Lift, Atlas Copco, Chicago Pneumatic, Allmand, Miller Curber, Skyjack, Lull, Skytrak, Tsurumi, Husquvarna Target, Stow, Wacker, Sakai, Mi-T-M, Sullair, Basic, Dynapac, MBW, Weber, Bartell, Bennar Newman, Haulotte, Ditch Runner, Menegotti, Morrison, Contec, Buddy, Crown, Edco, Wyco, Bomag, Laymor, EZ Trench, Bil-Jax, F.S. Curtis, Gehl Pavers, Heli, Honda, ICS/PowerGrit, IHI, Partner, Imer, Clipper, MMD, Koshin, Rice, CH&E, General Equipment, Amida, Coleman, NAC, Gradall, Square Shooter, Kent, Stanley, Tamco, Toku, Hatz, Kohler, Robin, Wisconsin, Northrock, Oztec, Toker TK, Rol-Air, APT, Wylie, Ingersoll Rand / Doosan, Innovatech, Con X, Ammann, Mecalac, Makinex, Smith Surface Prep, Small Line, Wanco, Yanmar