



REVISED STARTING  
SERIAL # 181010494

## PARTS LIST MANUAL MODEL MS20



### 20" ELECTRIC POWERED MASONRY SAWS

SKU #	MODEL #	POWER OPTION
21200	MS20-5B/230/1	BALDOR ELECTRIC MOTOR 5HP 230V 1-PHASE 60HZ
21500-230	MS20-5B/230/3	BALDOR ELECTRIC MOTOR 5HP 230V 3-PHASE 60HZ
21500-460	MS20-5B/460/3	BALDOR ELECTRIC MOTOR 5HP 460V 3-PHASE 60HZ
21300-230	MS20-7.5B/230/3	BALDOR ELECTRIC MOTOR 7.5HP 230V 3-PHASE 60HZ
21300-460	MS20-7.5B/460/3	BALDOR ELECTRIC MOTOR 7.5HP 460V 3-PHASE 60HZ

**READ AND UNDERSTAND THE OPERATOR'S SAFETY MANUAL THOROUGHLY  
BEFORE ATTEMPTING TO OPERATE THIS EQUIPMENT.**

Death or serious injury could occur if this machine is used improperly.

Machine specific Operator's Instruction Manuals are offered at [www.discount-equipment.com](http://www.discount-equipment.com) READ AND UNDERSTAND  
THE ENGINE MANUFACTURERS INSTRUCTIONS AND OPERATORS MANUAL BEFORE OPERATION.



# PARTS FINDER

**Search Website  
by Part Number**



**Search Manual  
Library For Parts  
Manual & Lookup Part  
Numbers – Purchase  
or Request Quote**

**Search Manuals**

Enter your information to help us find the right parts manual for your machine.

\* Brand:

\* Model:

\* Serial:

\* Part Number:

SEARCH

**Can't Find Part or  
Manual? Request Help  
by Manufacturer,  
Model & Description**

**Parts Order Form**

Please fill in the following information to help us find the right part for your machine.

Manufacturer:	<input type="text"/>
Model:	<input type="text"/>
Description:	<input type="text"/>
Part Number:	<input type="text"/>
Quantity:	<input type="text"/>
Notes:	<input type="text"/>
Submit	<input type="button" value="Submit"/>

Discount-Equipment.com is your online resource for quality parts & equipment.

Florida: **561-964-4949** Outside Florida TOLL FREE: **877-690-3101**

**Need parts?**

Click on this link: <http://www.discount-equipment.com/category/5443-parts/> and choose one of the options to help get the right parts and equipment you are looking for. Please have the machine model and serial number available in order to help us get you the correct parts. If you don't find the part on the website or on one of the online manuals, please fill out the request form and one of our experienced staff members will get back to you with a quote for the right part that your machine needs.

We sell worldwide for the brands: Genie, Terex, JLG, MultiQuip, Mikasa, Essick, Whiteman, Mayco, Toro Stone, Diamond Products, Generac Magnum, Airman, Haulotte, Barreto, Power Blanket, Nifty Lift, Atlas Copco, Chicago Pneumatic, Allmand, Miller Curber, Skyjack, Lull, Skytrak, Tsurumi, Husquvarna Target, Stow, Wacker, Sakai, Mi-T-M, Sullair, Basic, Dynapac, MBW, Weber, Bartell, Bennar Newman, Haulotte, Ditch Runner, Menegotti, Morrison, Contec, Buddy, Crown, Edco, Wyco, Bomag, Laymor, EZ Trench, Bil-Jax, F.S. Curtis, Gehl Pavers, Heli, Honda, ICS/PowerGrit, IHI, Partner, Imer, Clipper, MMD, Koshin, Rice, CH&E, General Equipment, Amida, Coleman, NAC, Gradall, Square Shooter, Kent, Stanley, Tamco, Toku, Hatz, Kohler, Robin, Wisconsin, Northrock, Oztec, Toker TK, Rol-Air, APT, Wylie, Ingersoll Rand / Doosan, Innovatech, Con X, Ammann, Mecalac, Makinex, Smith Surface Prep, Small Line, Wanco, Yanmar

# SAFETY INFORMATION

## SAFETY MESSAGES

• Safety Instructions are preceded by a graphic alert symbol of DANGER, WARNING, or CAUTION.

**DANGER** Indicates an imminent hazard which, if not avoided, will result in death or serious injury.

**WARNING** Indicates an imminent hazard which, if not avoided, can result in death or serious injury.

**CAUTION** Indicates hazards which, if not avoided, could result in serious injury and or damage to the equipment.

## GASOLINE / PROPANE POWERED EQUIPMENT

**WARNING** • Engine exhaust from this product contains chemicals known to the State of California to cause cancer, birth defects or other reproductive harm.

**WARNING** • Tilting a gasoline powered machine fitted with an EPA approved vented charcoal filter gas cap, beyond 20° can cause fuel leakage. If a leak occurs, do not start or run the engine until the leak is fixed. Eliminate all other ignition sources in the immediate area (no smoking, flares, sparks or flames). Use approved gasoline absorbing material to contain the fuel leakage. Then use clean, non-sparking tools to collect absorbed materials then dispose of these contaminants properly.

**X** • Gasoline is extremely flammable and poisonous. It should only be dispensed in well ventilated areas, and with a cool engine.

• Small gasoline engines produce high concentrations of carbon monoxide (CO) example: a 5 HP 4 cycle engine operation in an enclosed 100,000 cu. ft. area with only one change of air per hour is capable of providing deadly concentrations of CO in less than fifteen minutes. Five changes of air in the same area will produce noxious fumes in less than 30 minutes. Gasoline powered equipment should not be used in enclosed or partially enclosed areas. Symptoms of CO poisoning include, head-ache, nausea, weakness, dizziness, visual problems and loss of consciousness. If symptoms occur - get into fresh air and seek medical attention immediately.

- Never refuel a hot engine or an engine while it is running.
- Engines are shipped from factory without fuel/oil.

**X** • Propane is extremely flammable and is heavier than air and tends to settle in low areas where a spark or flame could ignite gas. DO NOT start or operate this propane engine in a poorly ventilated area where leaking propane gas could accumulate and endanger safety of persons in area. If headache develops, shut off machine. Have it checked for carbon monoxide emissions by a qualified technician before using it again. To ensure personal safety, installation and repair of propane fuel supply systems must be performed only by qualified technicians. Carbon monoxide emissions from this machine are greatly increased due to a dirty combustion air cleaner.

## ELECTRICAL POWERED EQUIPMENT

**⚡** Extreme care must be taken when operating electric models with water present: Ensure power cord is properly grounded, is attached to a Ground-Fault-Interrupter (GFI) outlet, and is undamaged.

- Check all electrical cables - be sure connections are tight and cable is continuous and in good condition. Be sure cable is correctly rated for both the operating current and voltage of this equipment.
- Improper connection of the equipment grounding conductor can result in a risk of electric shock. Check with qualified electrician or service person if there is any doubt as to whether the outlet is properly grounded. Adhere to all local codes and ordinances.
- NOTE: In the event of a malfunction or breakdown, grounding provides a path of least resistance for the electric current to dissipate. The motor is equipped with a grounded plug and must be connected to an outlet that is properly installed and properly grounded. DO NOT modify the plug provided on the motor. If the plug does not fit the outlet have a qualified electrician install the proper receptacle.

## ELECTRICAL POWERED EQUIPMENT CONTINUED

- Do not disconnect power by pulling cord. To disconnect, grasp the plug, not the cord.
- Unplug power cord at the machine when not in use and before servicing.
- Switch motor OFF before disconnecting power.
- Never use frayed, damaged, taped or under rated extension cords. Electrical shock could result in death or serious injury to the operator and damage to the equipment.
- Assure you are using the proper extension cord length.

## GENERAL INSTRUCTIONS

- Equipment should only be operated by trained personnel in good physical condition and mental health (not fatigued). The operator and maintenance personnel must be physically able to handle the bulk weight and power of this equipment.
- This is a one person tool. Maintain a safe operating distance to other personnel. It is the operators' responsibility to keep other people (workers, pedestrians, bystanders, etc.) away during operation. Block off the work area in all directions with roping, safety netting, etc. Failure to do so may result in others being injured by flying debris or exposing them to harmful dust and noise.
- This equipment is intended for commercial use only.
- For the operator's safety and the safety of others, always keep all guards in place during operation.
- Never let equipment run unattended.



- Personal Protection Equipment and proper safety attire must be worn when operating this machinery. The operator must wear approved safety equipment appropriate for the job such as hard hat and safety shoes when conditions require. Hearing protection **MUST** be used when operational noise levels of this equipment may exceed 85db. Eye protection **MUST** be worn at all times.



Keep body parts, loose clothing and accessories away from moving parts. Failure to do so could result in dismemberment or death.

- Do not modify the machine.
- Stop motor/engine when adjusting or servicing this equipment. Maintain a safe operating distance from flammable materials. Sparks from the cutting-action of this machine can ignite flammable materials or vapors.



## DUST WARNING

**WARNING** Some dust created by power sanding, sawing, grinding, drilling, and other construction activities contains chemicals known to cause cancer, birth defects, or other reproductive harm. Materials being removed can be toxic or hazardous. A breathing respirator is required to help protect the operator. Some examples of these chemicals are:

- Lead from lead-based paints.
- Crystalline silica from bricks, concrete and other masonry products. Your risk of exposure to these chemicals varies depending on how often you do this type of work. To reduce your risk: work in a well ventilated area, use a dust control system, such as an industrial-style vacuum, and wear approved personal safety equipment, such as a dust/particle respirator designed to filter out microscopic particles.
- See more on the importance of dust prevention and silica warnings at: [osha.gov/silica](http://osha.gov/silica)
- More concrete and silica dust suppression training and educational materials available at [edcoinc.com/silica-standards](http://edcoinc.com/silica-standards) or scan the QR code on page 5.
- Written exposure plans are provided at <http://www.edcoinc.com/written-exposure-control-plans/>

# PARTS LIST MANUAL

## MODEL MS20

### TABLE OF CONTENTS

<u>Section</u>	<u>Page Number</u>
Safety Information .....	2
How To Order Replacement Parts .....	3
Illustration 1: Main Grouping .....	4, 5
Illustration 2: Foot Pedal & Linkage Grouping .....	6, 7
Illustration 3: Main Deck & Belt Drive Grouping .....	8, 9
Illustration 4: Arbor Assembly .....	10
Illustration 5: Rolling Table Assembly .....	11
Illustration 6: Blade Guard & Water Pump Grouping .....	12, 13
Illustration 7: Motor Grouping .....	14, 15
Wiring Diagram for Starter & Water Pump Outlet (Single-Phase) .....	16
Wiring Diagram for Starter (Three-Phase) .....	17
Wiring Diagram for Single-Phase 60Hz Motor .....	18
Wiring Diagram for Three-Phase 60Hz Motor .....	19
Decal Sheet 1 .....	20
Decal Sheet 2 .....	21
Notes .....	22
Limited Equipment Warranty of Sale - Terms & Conditions .....	23
STOP - Before Using This Product .....	24

ILLUSTRATION 1: MAIN GROUPING

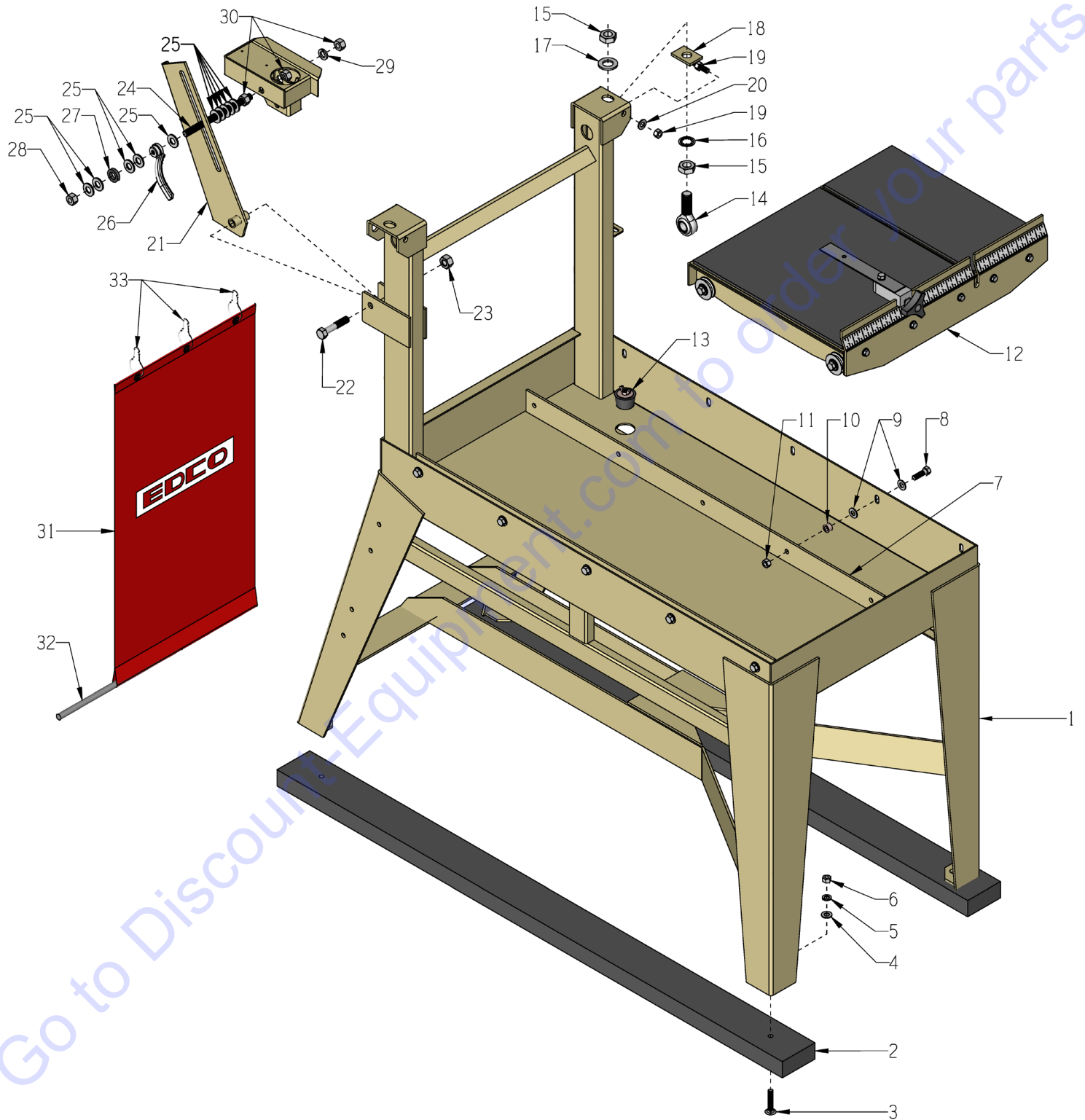

**PARTS LISTING - ILLUSTRATION 1: MAIN GROUPING**

ITEM #	PART #	DESCRIPTION	QTY.
1	41106	STAND & PAN WELDMENT, MS-20	1
2	41002	SKID BOARD 2 X 4 X 54"L, GMS/MS-20	2
3	10364	BOLT, CARRIAGE 3/8-16 X 2 GRADE 5	4
4	10025	WASHER, FLAT 3/8 SAE ZINC	4
5	10811	WASHER, LOCK 3/8 ZINC	4
6	10404	NUT, HEX 3/8-16 ZINC	4
7	41003	RAIL, GUIDE, GMS/MS-20	2
8	10309	SCREW, CAP 3/8-24 X 1-1/4 ZINC	10
9	10025	WASHER, FLAT 3/8 SAE ZINC	20
10	10011	SPACER, STEEL 5/8OD X 3/8ID X 3/8T	10
11	10004	NUT, HEX LOCK 3/8-24 ZINC	10
12	41101	TABLE COMPLETE, ROLLING, MS/GMS-20 (REFER TO ILLUSTRATION 5 FOR BREAKDOWN)	1
13	40378	STOPPER ASSEMBLY 1-1/2"	1
14	10935	ROD END, MALE 3/4-16	2
15	10429	NUT, HEX JAM 3/4-16 ZINC	4
16	10609	WASHER, LOCK, INT. TOOTH 3/4"	2
17	10009	WASHER, FLAT 3/4 SAE ZINC	2
18	41107	ADJUSTER, HEAD, MS-20	2
19	10404	NUT, HEX 3/8-16 ZINC	4
20	10025	WASHER, FLAT 3/8 SAE ZINC	2
21	41021	PLATE, PIVOT LOCK, GMS/MS-20	1
22	10343	SCREW, CAP 1/2-20 X 2-1/2	1
23	10205	NUT, HEX LOCK 1/2-20 ZINC	1
24	41108	ROD, ALLTHREAD 1/2-13 X 7"L	1
25	10312	WASHER, FLAT 1/2 SAE ZINC (QTY. & SPACING MAY VARY)	11
26	40358	NUT, TAIL HANDLE 1/2-13	1
27	79035	BUSHING, RUBBER 1-1/16 X 5/8 X 1/4	1
28	10155	NUT, HEX NYLON LOCK 1/2-13 ZINC	1
29	10045	WASHER, LOCK 1/2 ZINC	1
30	10417	NUT, HEX 1/2-13 ZINC	3
31	40375	CURTAIN 15" X 28" W/ LOGO	1
32	40377	CURTAIN ROD 1/2"DIA. X 13"L	1
33	40376	HOOK, CURTAIN	3

# ILLUSTRATION 2: FOOT PEDAL & LINKAGE GROUPING

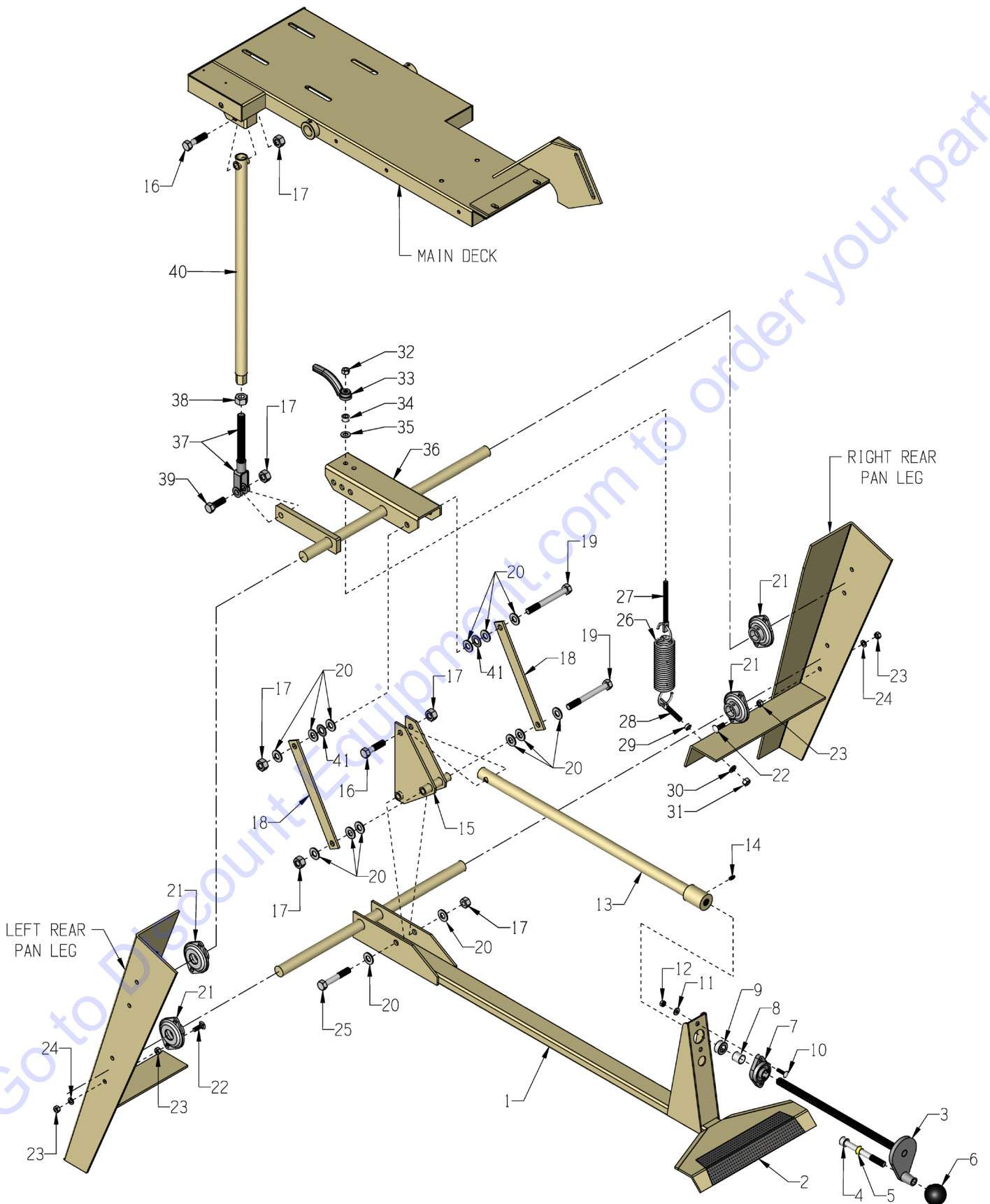

**PARTS LISTING - ILLUSTRATION 2: FOOT PEDAL & LINKAGE GROUPING**

ITEM #	PART #	DESCRIPTION	QTY.
1	41121	TREADLE (FOOT PEDAL) MS/GMS-20	1
2	41132	TREAD, ABRASIVE, FOOT PEDAL	1
3	41012	HANDWHEEL, SMALL W/ 5/8-8 X 15"ROD	1
4	10346	SCREW, SKT. HD. CAP 1/2-13 X 4-1/2	1
5	50550	SLEEVE, BRASS 1/2" TAPERED	1
6	10104	KNOB, BALL 1-7/8 W/ 1/2-13THD, BLK.	1
7	80009	BEARING, BALL 5/8" 2-HOLE (NO G.F.)	1
8	55010	SPACER, HANDWHEEL 5/8"ID X 3/4"L	1
9	10096	COLLAR, LOCKING 5/8"ID	1
10	10412	BOLT, CARRIAGE 1/4-20 X 1 FULL THD.	2
11	10602	WASHER, FLAT 1/4 SAE ZINC	2
12	10861	NUT, KEPS LOCK 1/4-20 ZINC	2
13	41013	LINKAGE, CUT CONTROL, GMS/MS-20	1
14	10808	FITTING, GREASE 1/4-28 STRAIGHT	1
15	41014	LINKAGE, PIVOT, MS/GMS-20	1
16	10322	SCREW, CAP 1/2-20 X 2	2
17	10205	NUT, HEX LOCK 1/2-20 ZINC	6
18	41015	LINKAGE, CONNECTING, MS/GMS-20	2
19	10409	SCREW, CAP 1/2-20 X 4-1/2	2
20	10312	WASHER, FLAT 1/2 SAE ZINC	14
21	41060	BEARING, BALL 1" 2-HOLE SHEET METAL	4
22	10819	BOLT, CARRIAGE 5/16-18 X 1 FULL THD	8
23	10054	NUT, HEX 5/16-18 ZINC	16
24	10801	WASHER, LOCK 5/16 ZINC	8
25	10202	SCREW, CAP 1/2-20 X 3	1
26	41041	SPRING, EXT. 1.75"OD X 8"L	2
27	10845	BOLT, SPADE 3/8-16 X 4-1/2	1
28	10843	BOLT, SPADE 3/8-16 X 1-5/8	1
29	10011	SPACER, STEEL 5/8OD X 3/8ID X 3/8T	1
30	10811	WASHER, LOCK 3/8 ZINC	1
31	10404	NUT, HEX 3/8-16 ZINC	1
32	10810	NUT, HEX LOCK 3/8-16 ZINC	1
33	40044	NUT, TAIL HANDLE 3/8-16	1
34	10011	SPACER, STEEL 5/8OD X 3/8ID X 3/8T	1
35	10025	WASHER, FLAT 3/8 SAE ZINC	1
36	41122	TREADLE, TRANSFER ARM, MS/GMS-20	1
37	41019	LINKAGE, CLEVIS, MS/GMS-20	1
38	10046	NUT, HEX 5/8-11 ZINC	1
39	10308	SCREW, CAP 1/2-20 X 1-1/2	1
40	41018	LINKAGE, DRAG, GMS/MS-20	1
41	10040	WASHER, GARRET 17/32 X 1 X .054	2



# ILLUSTRATION 3: MAIN DECK & BELT DRIVE GROUPING

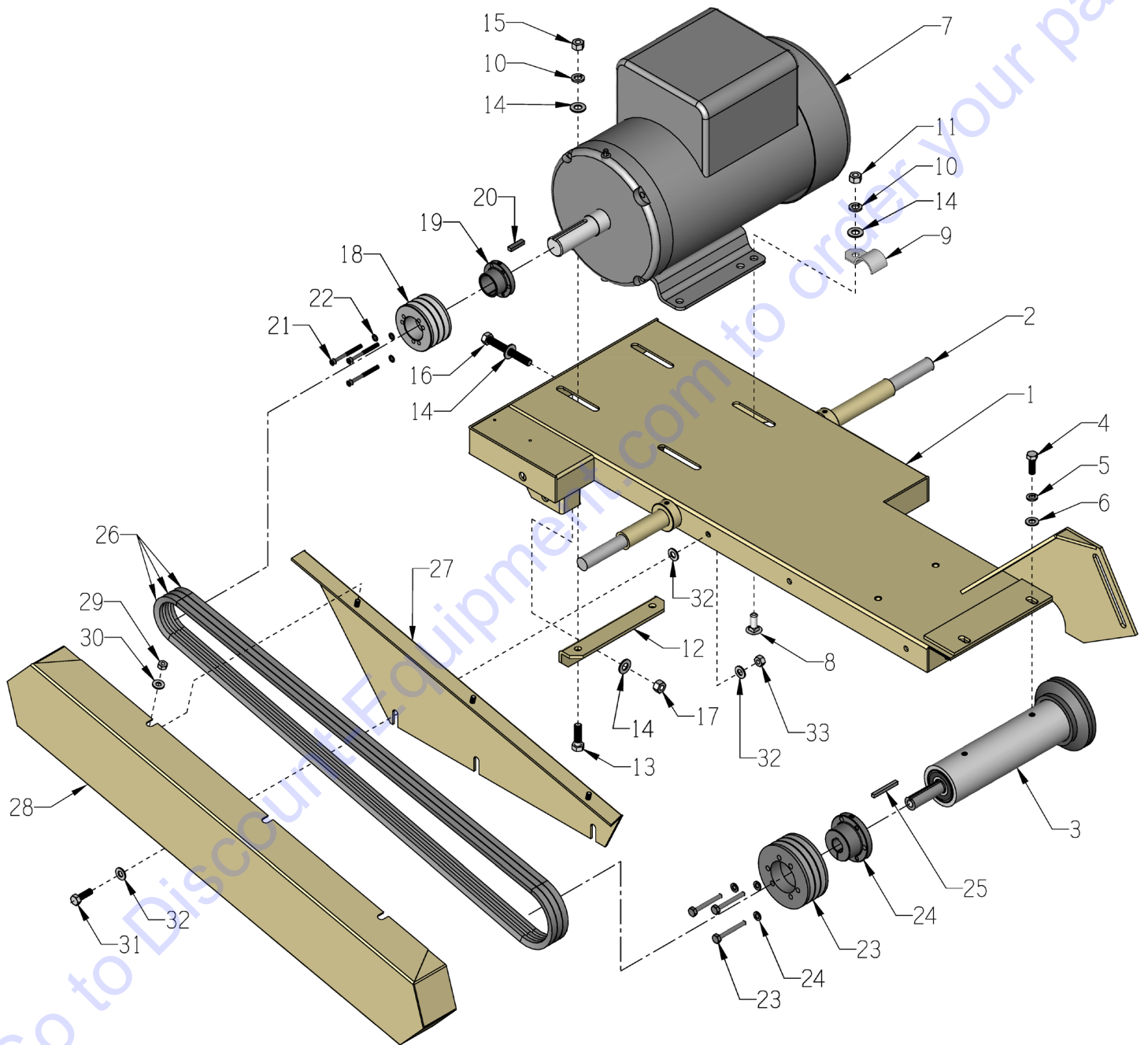

**PARTS LISTING - ILLUSTRATION 3: MAIN DECK & BELT DRIVE GROUPING**

ITEM #	PART #	DESCRIPTION	QTY.
1	41112	DECK, MAIN, MS-20	1
2	41120	SHAFT, PIVOT, MS-20	1
3	41113	ARBOR ASSY. COMPLETE (REFER TO ILLUS. 4 FOR BREAKDOWN)	1
4	10332	SCREW, CAP 5/16-24 X 1	4
5	10801	WASHER, LOCK 5/16 ZINC	4
6	10213	WASHER, FLAT 5/16 SAE ZINC	4
7	-----	MOTOR (REFER TO ILLUS. 7 FOR DETAILS)	1
8	10802	BOLT, CARRIAGE 3/8-16 X 1 ZINC	2
9	41124	CLAMP, CONDUIT 1/2"PIPE (13/16")	2
10	10811	WASHER, LOCK 3/8 ZINC	4
11	10404	NUT, HEX 3/8-16 ZINC	2
12	41109	TENSIONER, MS-20	1
13	10309	SCREW, CAP 3/8-24 X 1-1/4 ZINC	2
14	10025	WASHER, FLAT 3/8 SAE ZINC	6
15	10014	NUT, HEX 3/8-24 ZINC	2
16	28025	BOLT, TAP 3/8-16 X 3 (FULL THREAD)	1
17	10156	NUT, HEX NYLON LOCK 3/8-16 ZINC	1
18	10534	SHEAVE 2.65"OD X 3GR.3V X JA	1
19	10533	BUSHING, SHEAVE JA X 1-1/8"BORE	1
20	10179	KEY 1/4 X 3/16 X 1	1
21	11584	SCREW, SKT. HD. CAP 10-24 X 2	3
22	10831	WASHER, LOCK, INT. TOOTH #10	3
23	10539	SHEAVE 3.65"OD X 3GR.3V X SH INCLUDES: (3) 1/4-20 X 2 CAPSCREWS	1
24	10532	BUSHING, SHEAVE SH X 3/4"BORE INCLUDES: (3) 1/4" LOCKWASHERS	1
25	10170	KEY 3/16SQ X 1-3/4	1
26	10257	BELT 3VX-630 COG	3
27	41111	BRACKET, BELT COVER, MS-20	1
28	41110	COVER, BELT, MS-20	1
29	10861	NUT, KEPS LOCK 1/4-20 ZINC	3
30	10602	WASHER, FLAT 1/4 SAE ZINC	3
31	10053	SCREW, CAP 5/16-18 X 3/4	2
	10806	SCREW, CAP 5/16-18 X 1 (SHOWN)	1
32	10213	WASHER, FLAT 5/16 SAE ZINC	7
33	10807	NUT, HEX LOCK 5/16-18 ZINC	3

### ILLUSTRATION 4: ARBOR ASSEMBLY

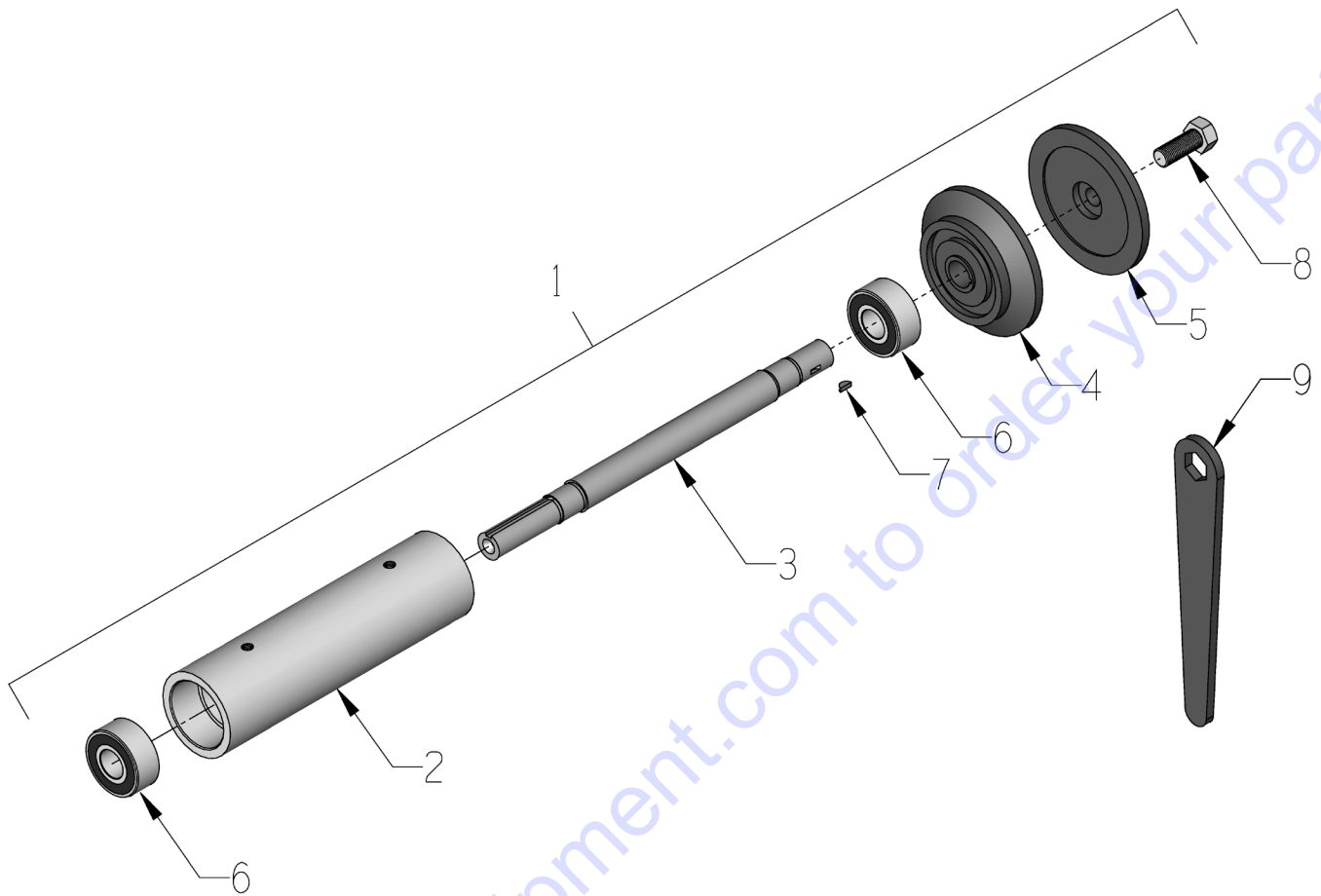

ITEM #	PART #	DESCRIPTION	QTY.
1	41113	ARBOR ASSY. COMPLETE (INCLUDES ITEMS 2 THRU 8)	1
2	41024	ARBOR HOUSING, GMS/MS-20	1
3	41025	ARBOR SHAFT 11-3/4"L, GMS/MS-20	1
4	40022	ARBOR BACKING PLATE 4", MASONRY SAW	1
5	40023	ARBOR BLADE CAP 4", MASONRY SAW	1
6	40018	BEARING, RADIAL BALL 20X47X20.6MM	2
7	40036	KEY, WOODRUFF 1/8 X 3/8 (SAE #213)	1
8	10321	SCREW, CAP 1/2-20 X 1-1/4	1
9	53021	WRENCH, ARBOR, 3/4" BOX END (NOT INCLUDED WITH ITEM 1)	1

# PARTS FINDER

**Search Website  
by Part Number**



**Search Manual  
Library For Parts  
Manual & Lookup Part  
Numbers – Purchase  
or Request Quote**

**Search Manuals**

Enter your information to help us find the right parts manual for your machine.

\* Brand:

\* Model:

\* Serial:

\* Part Number:

SEARCH

**Can't Find Part or  
Manual? Request Help  
by Manufacturer,  
Model & Description**

**Parts Order Form**

Please fill in the following information to help us find the right part for your machine.

Manufacturer:	<input type="text"/>
Model:	<input type="text"/>
Description:	<input type="text"/>
Part Number:	<input type="text"/>
Quantity:	<input type="text"/>
Notes:	<input type="text"/>

Submit

Discount-Equipment.com is your online resource for quality parts & equipment.

Florida: **561-964-4949** Outside Florida TOLL FREE: **877-690-3101**

**Need parts?**

Click on this link: <http://www.discount-equipment.com/category/5443-parts/> and choose one of the options to help get the right parts and equipment you are looking for. Please have the machine model and serial number available in order to help us get you the correct parts. If you don't find the part on the website or on one of the online manuals, please fill out the request form and one of our experienced staff members will get back to you with a quote for the right part that your machine needs.

We sell worldwide for the brands: Genie, Terex, JLG, MultiQuip, Mikasa, Essick, Whiteman, Mayco, Toro Stone, Diamond Products, Generac Magnum, Airman, Haulotte, Barreto, Power Blanket, Nifty Lift, Atlas Copco, Chicago Pneumatic, Allmand, Miller Curber, Skyjack, Lull, Skytrak, Tsurumi, Husquvarna Target, Stow, Wacker, Sakai, Mi-T-M, Sullair, Basic, Dynapac, MBW, Weber, Bartell, Bennar Newman, Haulotte, Ditch Runner, Menegotti, Morrison, Contec, Buddy, Crown, Edco, Wyco, Bomag, Laymor, EZ Trench, Bil-Jax, F.S. Curtis, Gehl Pavers, Heli, Honda, ICS/PowerGrit, IHI, Partner, Imer, Clipper, MMD, Koshin, Rice, CH&E, General Equipment, Amida, Coleman, NAC, Gradall, Square Shooter, Kent, Stanley, Tamco, Toku, Hatz, Kohler, Robin, Wisconsin, Northrock, Oztec, Toker TK, Rol-Air, APT, Wylie, Ingersoll Rand / Doosan, Innovatech, Con X, Ammann, Mecalac, Makinex, Smith Surface Prep, Small Line, Wanco, Yanmar

## ILLUSTRATION 5: ROLLING TABLE ASSEMBLY

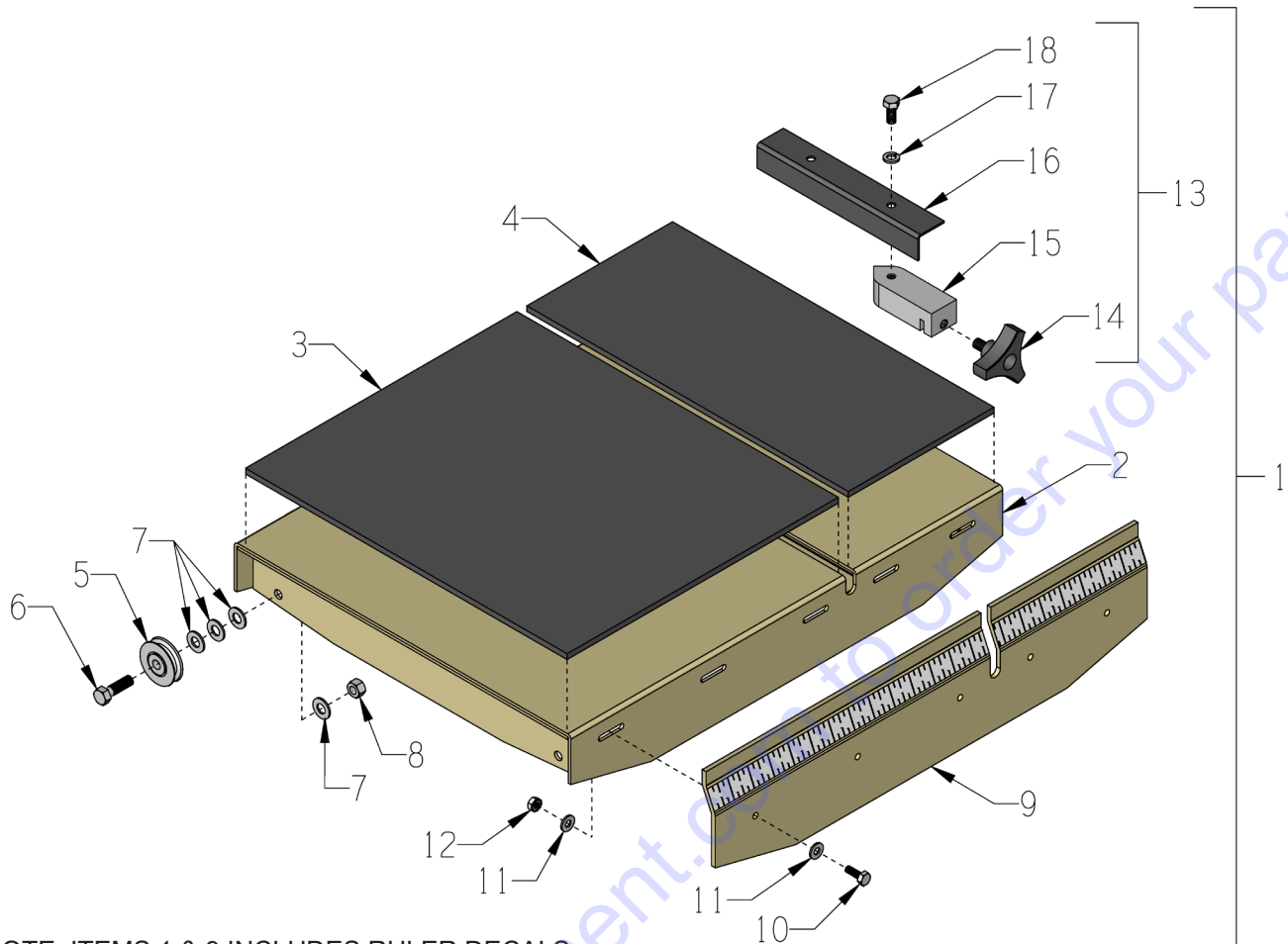

\* NOTE: ITEMS 1 & 9 INCLUDES RULER DECALS

ITEM #	PART #	DESCRIPTION	QTY.
1*	41101	TABLE COMPLETE, ROLLING (INCLUDES ITEMS 2 THRU 19)	1
2	41102	TABLE ONLY, ROLLING, GMS/MS-20	1
3	41006	RUBBER PAD 16 X 13-5/8 X 1/4	1
4	41007	RUBBER PAD 16 X 7-1/4 X 1/4	1
5	3621	PULLEY BEARING 1-3/4DIA. X 3/8BORE (A.K.A. TRACK WHEEL)	4
6	10816	SCREW, CAP 3/8-24 X 1-1/2	4
7	10025	WASHER, FLAT 3/8 SAE ZINC (**QTY. & SPACING MAY VARY)	16**
8	10058	NUT, HEX LOCK 3/8-24 W/ NYLON PATCH	4
9*	41103	FRONT PANEL, ROLL TABLE	1
10	10018	SCREW, CAP 1/4-20 X 3/4	5
11	10602	WASHER, FLAT 1/4 SAE ZINC	10
12	10861	NUT, KEPS LOCK 1/4-20 ZINC	5
13	40689A	GUIDE ASSY., CUT, UNIVERSAL (INCL. ITEMS 14 THRU 18)	1
14	40425	KNOB, 3-PRONG W/ 3/8-16 X 5/8 STUD	1
15	42015	BLOCK, CUT GUIDE, MASONRY SAW	1
16	40689	BRACKET, CUT GUIDE, UNIVERSAL	1
17	10801	WASHER, LOCK 5/16 ZINC	1
18	10053	SCREW, CAP 5/16-18 X 3/4	1

ILLUSTRATION 6: BLADE GUARD & WATER PUMP GROUPING

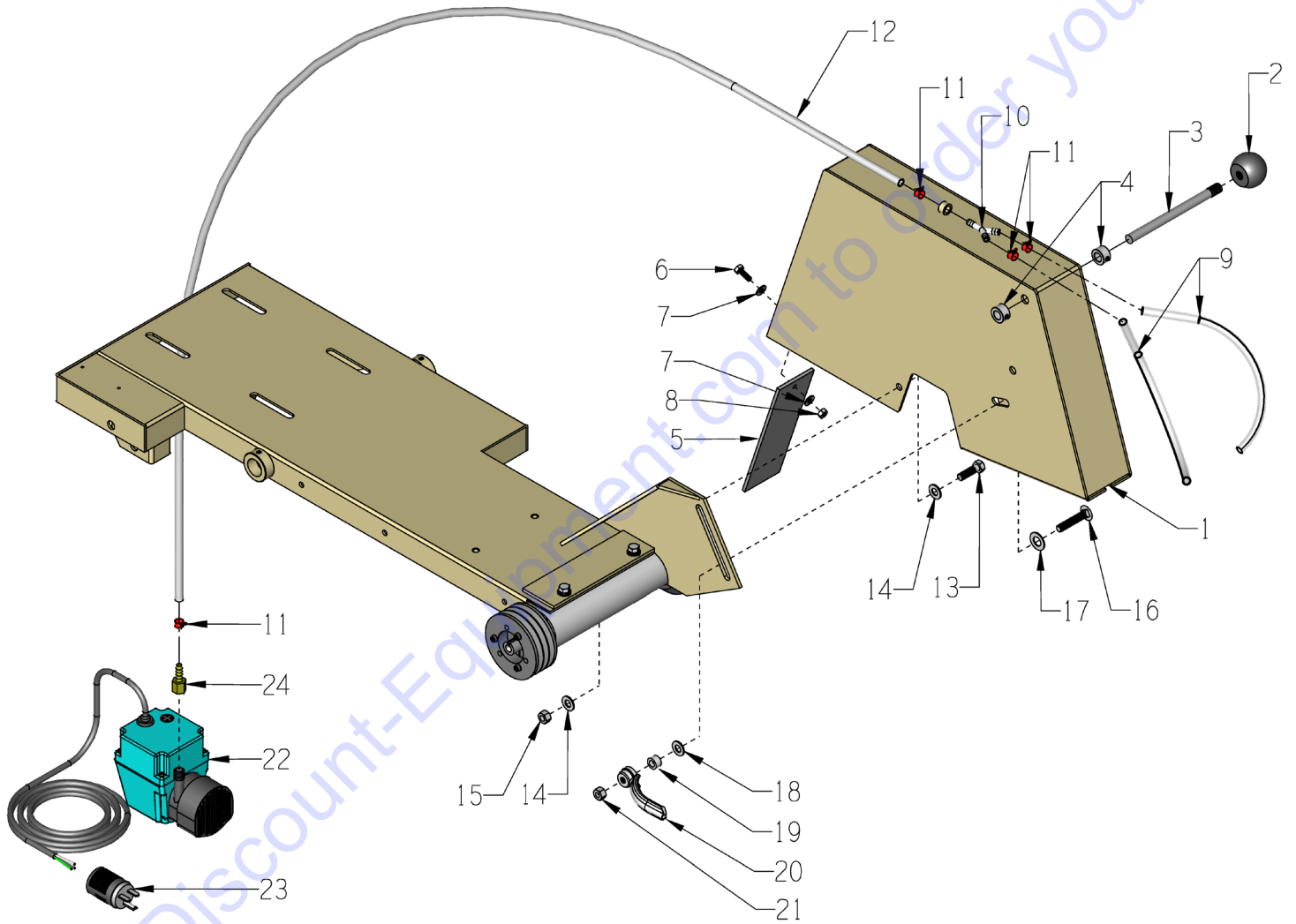

**PARTS LISTING - ILLUSTRATION 6:  
BLADE GAURD & WATER PUMP GROUPING**

ITEM #	PART #	DESCRIPTION	QTY.
1	41026	GUARD, BLADE 20", GMS/MS-20	1
2	10104	KNOB, BALL 1-7/8 W/ 1/2-13THD, BLK.	1
3	41027	SHAFT, HANDLE, GMS/MS-20	1
4	10431	COLLAR, LOCKING 1/2"ID	2
5	41115	FLAP, RUBBER 2-1/2 X 8	1
6	10018	SCREW, CAP 1/4-20 X 3/4	1
7	10602	WASHER, FLAT 1/4 SAE ZINC	2
8	10015	NUT, HEX LOCK 1/4-20 ZINC	1
9	41061	HOSE 5/16"ID X 12"L, GMS/MS-20	2
10	11721	BARBED FITTING, "Y" 5/16"HOSE	1
11	10763	CLAMP, HOSE, SPRING-BAND 7/16"	4
12	41116	HOSE 5/16"ID X 50"L, MS-20	1
13	10309	SCREW, CAP 3/8-24 X 1-1/4 ZINC	1
14	10025	WASHER, FLAT 3/8 SAE ZINC	2
15	10004	NUT, HEX LOCK 3/8-24 ZINC	1
16	10364	BOLT, CARRIAGE 3/8-16 X 2 GRADE 5	1
17	10312	WASHER, FLAT 1/2 SAE ZINC	1
18	10025	WASHER, FLAT 3/8 SAE ZINC	1
19	10011	SPACER, STEEL 5/8OD X 3/8ID X 3/8T	1
20	40044	NUT, TAIL HANDLE 3/8-16	1
21	10810	NUT, HEX LOCK 3/8-16 ZINC	1
22	41117	PUMP, WATER, 230 VAC, SUBMERSIBLE	1
23	41118	PLUG, STRAIGHT 15A/250V NEMA 6-15P	1
24	10739	BARB, 5/16 HOSE X 1/4 FPT	1

ILLUSTRATION 7: MOTOR GROUPING

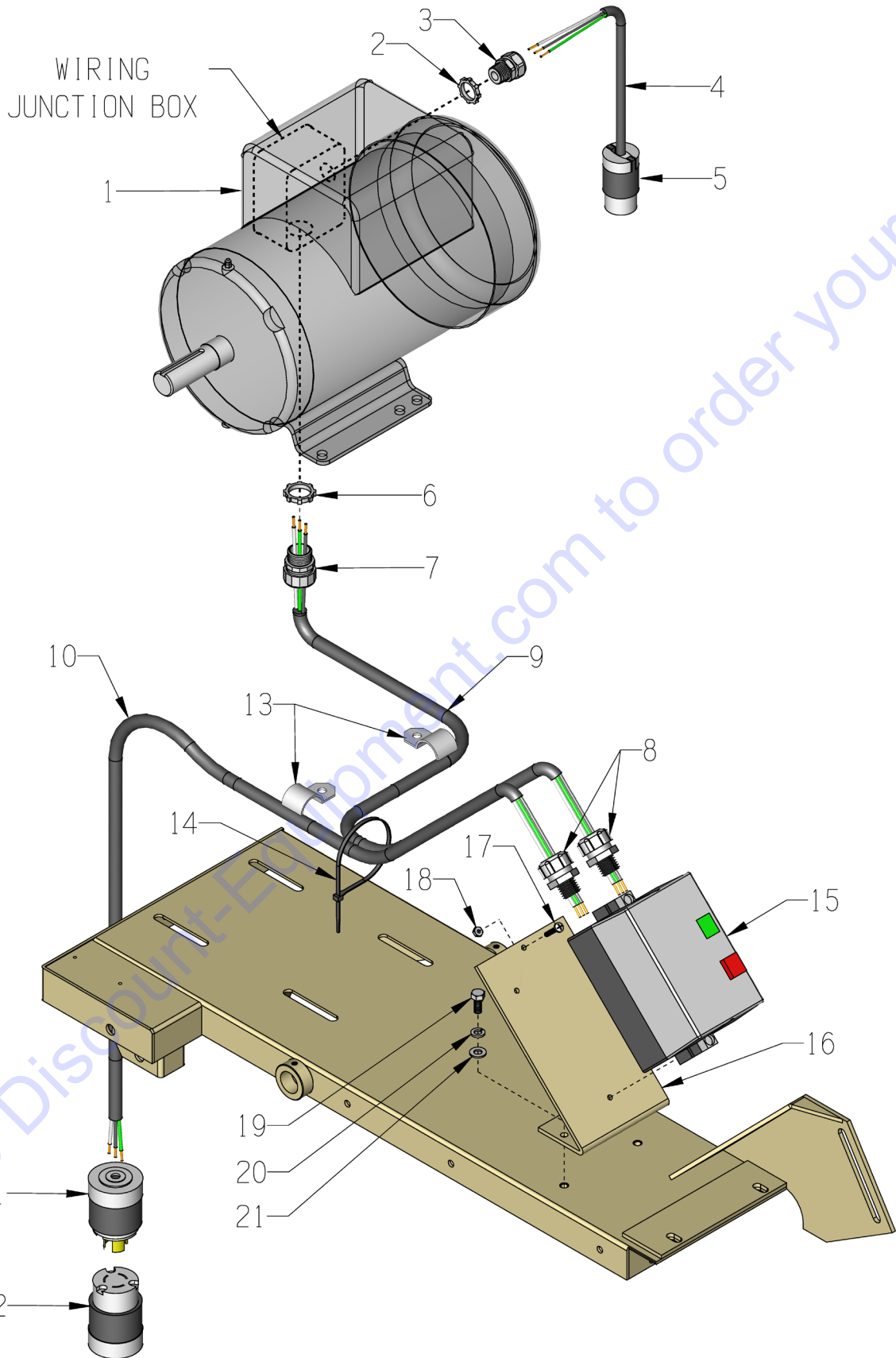



**PARTS LISTING - ILLUSTRATION 7: MOTOR GROUPING**

ITEM #	PART #	DESCRIPTION	QTY.
1	81026 81022 16002	MOTOR, BALDOR 5HP-1PH 60HZ 3450RPM 230V, 19.5 FLA (SHOWN) 5HP-3PH-60HZ-3450RPM 230/460V, 11.8/5.9 FLA 7.5HP-3P 60HZ 3450RPM 230/460V, 16.8/8.4 FLA	1
2*	10790	CONDUIT LOCK NUT 1/2 NP (LOCATED INSIDE WIRING BOX)	1
3*	40066	STRAIN RELIEF 1/2NPT X .350-.450"	1
4*	41129	WIRE HARNESS 16/3 X 15"LOA, MS-20	1
5*	41119	CONNECTOR, STR. 15A/250V 6-15R	1
6	10740	CONDUIT LOCK NUT 3/4 NP (LOCATED INSIDE WIRING BOX)	1
7	10605	STRAIN RELIEF 3/4NPT X .650-.750"	1
8	41053	STRAIN RELIEF 1/2NPT X .625-.750"	2
9	41125 41126	WIRE HARNESS SJOOW 300V (STARTER TO MOTOR) 10/3 X 50" (SINGLE PHASE) 10/4 X 50" (THREE PHASE)	1
10	41127 41128	WIRE HARNESS SJOOW 300V (POWER CORD) 10/3 X 50" (SINGLE PHASE) 10/4 X 50" (THREE PHASE)	1
11*	56323	PLUG, LOCKING 30A/250V L6-30P (SINGLE PHASE ONLY)	1
12*	56322	CONNECTOR, LOCKING 30A/250V L6-30C (SINGLE PHASE ONLY)	1
13	41124	CLAMP, CONDUIT 1/2"PIPE (13/16")	2
14	10982	TIE, CABLE, BLACK NYLON 11-1/4"	2
15	16410 16405 16406 16482  16652 16617 16618 16622 16623 16632 16633 16635 16637	STARTER ACI #128826 200/240V COIL 17.5-21.5A O/L STARTER ACI #128841 200/240V COIL 11.3-16A O/L STARTER ACI #128847 440/480V COIL 5.5-7.5A O/L STARTER ACI #128848 440/480V COIL 7.2-10A O/L REPLACEMENT PARTS: STARTER BOX ONLY, START-STOP STARTER CONT./COIL ACI SK18.310-230 STARTER CONT./COIL ACI SK18.310-460 STARTER AC COIL 200/240V-60HZ STARTER AC COIL 440/480V-60HZ STARTER OVERLOAD RELAY 5.5-7.5 AMP STARTER OVERLOAD RELAY 7.2-10.0 AMP STARTER OVERLOAD RELAY 11.3-16.0 AMP STARTER OVERLOAD RELAY 17.5-21.5 AMP	1 1 1 1  1 1 1 1 1 1 1 1 1 1
16	41134	MOUNT, ACI STARTER, MS-20	1
17	11732 10384	SCREW, MACHINE 10-32 X 1-3/4 RHP SCREW, MACHINE 10-32 X 1 RHP	2 1
18	10832	NUT, KEPS LOCK 10-32 ZINC	3
19	10053	SCREW, CAP 5/16-18 X 3/4	2
20	10801	WASHER, LOCK 5/16 ZINC	2
21	10213	WASHER, FLAT 5/16 SAE ZINC	2

\*NOTE: THESE ITEMS ARE NOT INCLUDED ON THREE-PHASE UNITS.

# WIRING DIAGRAM FOR STARTER ON 1-PHASE 60 HERTZ UNITS

MODEL:  
MS20-5B/230/1

INCLUDES WATER PUMP OUTLET  
CONNECTION TO MOTOR

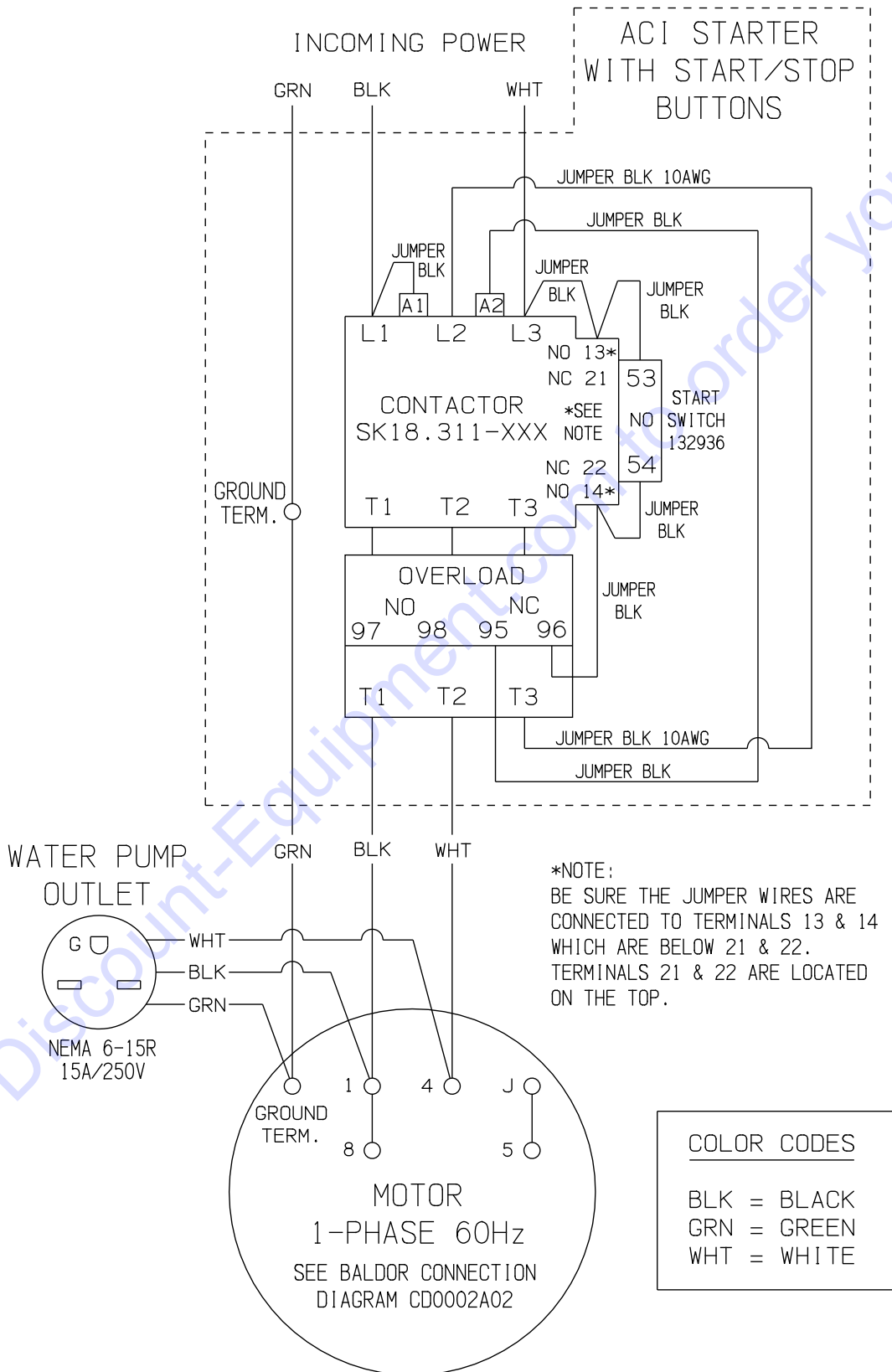

**WIRING DIAGRAM FOR STARTER  
ON 3-PHASE 60 HERTZ UNITS**

MODELS:  
MS20-5B/230/3  
MS20-5B/460/3  
MS20-7.5B/230/3  
MS20-7.5B/460/3

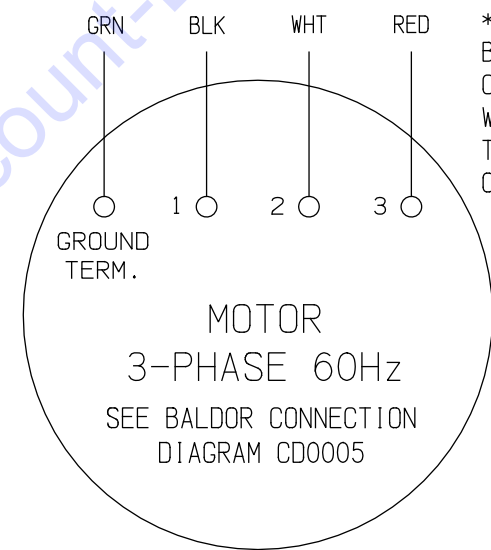
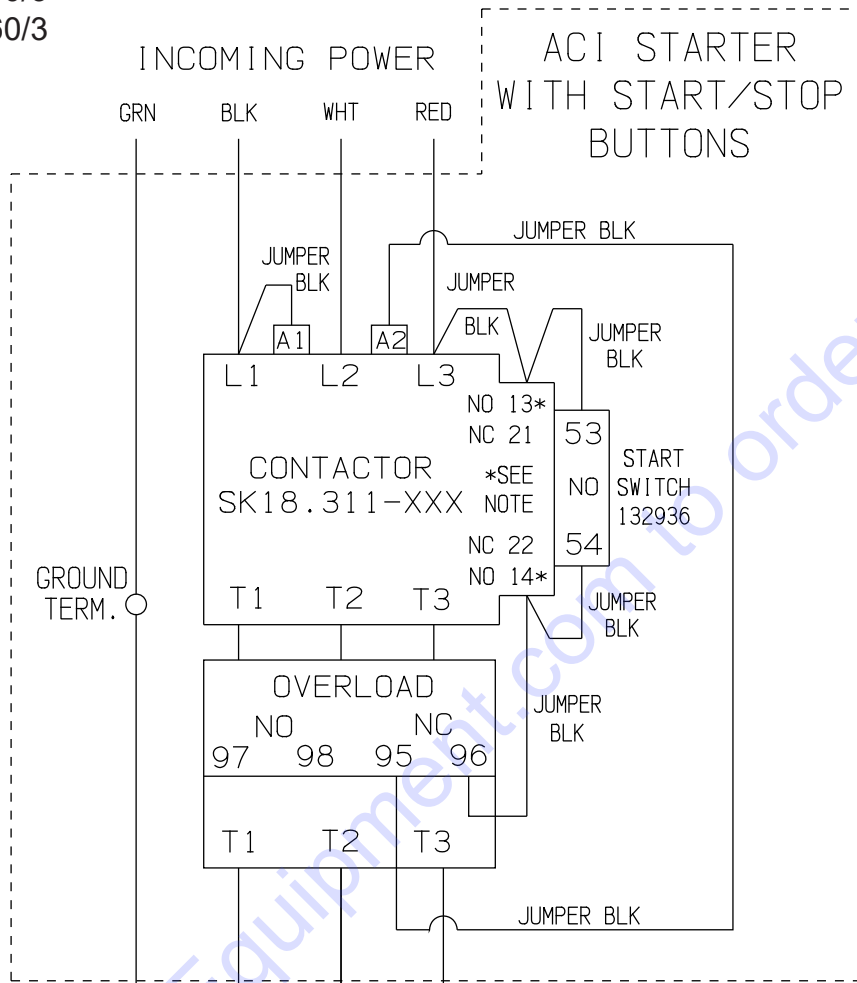

**\*NOTE:**  
BE SURE THE JUMPER WIRES ARE  
CONNECTED TO TERMINALS 13 & 14  
WHICH ARE BELOW 21 & 22.  
TERMINALS 21 & 22 ARE LOCATED  
ON THE TOP.

COLOR CODES	
BLK	= BLACK
GRN	= GREEN
RED	= RED
WHT	= WHITE

Go to Discount-Equipment.com to order your parts

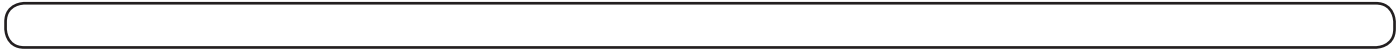

MODEL MS20-5B/230/1

**WIRING DIAGRAM FOR SINGLE-PHASE 60Hz MOTOR**

5HP BALDOR CAT. NO. L3608TM

CD0002A02

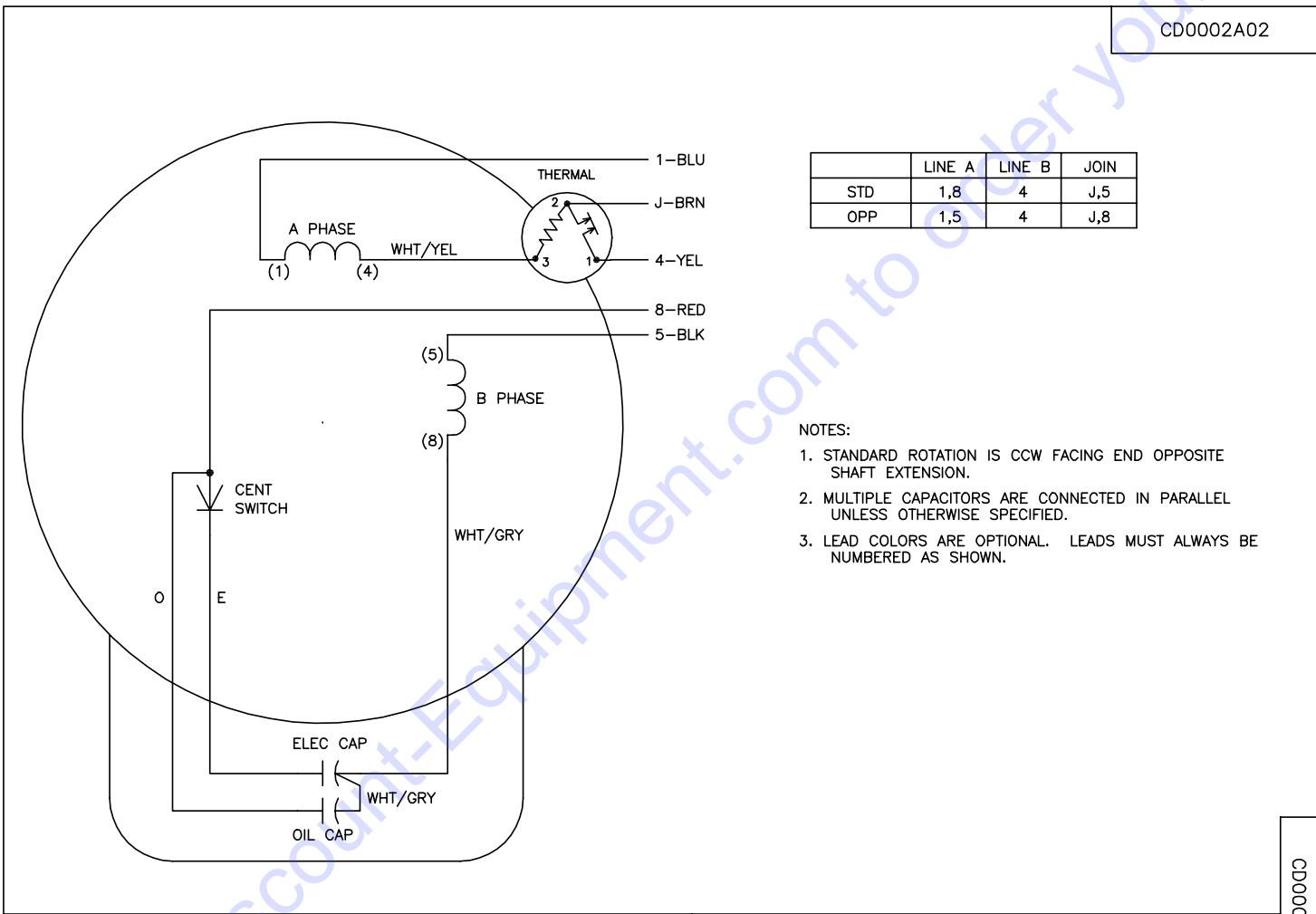

	LINE A	LINE B	JOIN
STD	1,8	4	J,5
OPP	1,5	4	J,8

- NOTES:
1. STANDARD ROTATION IS CCW FACING END OPPOSITE SHAFT EXTENSION.
  2. MULTIPLE CAPACITORS ARE CONNECTED IN PARALLEL UNLESS OTHERWISE SPECIFIED.
  3. LEAD COLORS ARE OPTIONAL. LEADS MUST ALWAYS BE NUMBERED AS SHOWN.

REV. DESC: REMOVE 2--TERMINAL THERMAL DETAIL, SEE CD0002A04		
REV. LTR: D	VERSION: 01	TDR: 000000360649
CD0002A02	FILE: \AAA\00007\520	REVISED: 17:11:40 04/15/2005
	MTL: -	BY: ENJOEPO

**BALDOR ELECTRIC Co.**

TYPE LC, SV, REV, THERMAL, 5 LEADS

CD0002A02

**WIRING DIAGRAM FOR THREE-PHASE 60Hz MOTOR**

5HP BALDOR CAT. NO. EM3613T  
 OR  
 7.5HP BALDOR CAT. NO. EM3616T

CD0005

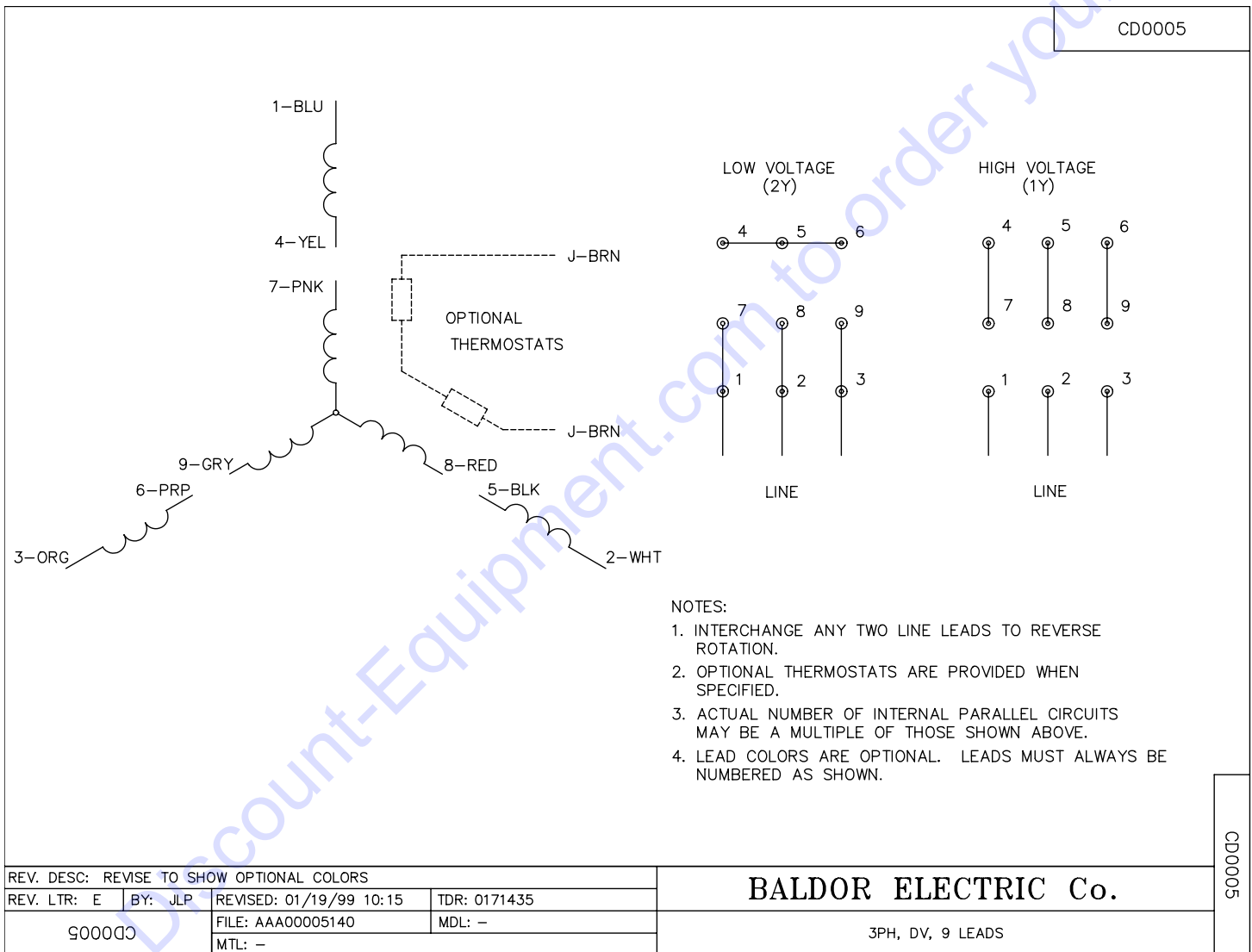

# PARTS FINDER

**Search Website  
by Part Number**



**Search Manual  
Library For Parts  
Manual & Lookup Part  
Numbers – Purchase  
or Request Quote**

**Search Manuals**

Enter your information to help us find the right parts manual for your machine.

\* Brand:

\* Model:

\* Serial:

\* Part Number:

SEARCH

**Can't Find Part or  
Manual? Request Help  
by Manufacturer,  
Model & Description**

**Parts Order Form**

Please fill in the following information to help us find the right part for your machine.

Manufacturer:	<input type="text"/>
Model:	<input type="text"/>
Description:	<input type="text"/>
Part Number:	<input type="text"/>
Quantity:	<input type="text"/>
Notes:	<input type="text"/>

Submit

Discount-Equipment.com is your online resource for quality parts & equipment.

Florida: **561-964-4949** Outside Florida TOLL FREE: **877-690-3101**

**Need parts?**

Click on this link: <http://www.discount-equipment.com/category/5443-parts/> and choose one of the options to help get the right parts and equipment you are looking for. Please have the machine model and serial number available in order to help us get you the correct parts. If you don't find the part on the website or on one of the online manuals, please fill out the request form and one of our experienced staff members will get back to you with a quote for the right part that your machine needs.

We sell worldwide for the brands: Genie, Terex, JLG, MultiQuip, Mikasa, Essick, Whiteman, Mayco, Toro Stone, Diamond Products, Generac Magnum, Airman, Haulotte, Barreto, Power Blanket, Nifty Lift, Atlas Copco, Chicago Pneumatic, Allmand, Miller Curber, Skyjack, Lull, Skytrak, Tsurumi, Husquvarna Target, Stow, Wacker, Sakai, Mi-T-M, Sullair, Basic, Dynapac, MBW, Weber, Bartell, Bennar Newman, Haulotte, Ditch Runner, Menegotti, Morrison, Contec, Buddy, Crown, Edco, Wyco, Bomag, Laymor, EZ Trench, Bil-Jax, F.S. Curtis, Gehl Pavers, Heli, Honda, ICS/PowerGrit, IHI, Partner, Imer, Clipper, MMD, Koshin, Rice, CH&E, General Equipment, Amida, Coleman, NAC, Gradall, Square Shooter, Kent, Stanley, Tamco, Toku, Hatz, Kohler, Robin, Wisconsin, Northrock, Oztec, Toker TK, Rol-Air, APT, Wylie, Ingersoll Rand / Doosan, Innovatech, Con X, Ammann, Mecalac, Makinex, Smith Surface Prep, Small Line, Wanco, Yanmar