

REVISED STARTING
SERIAL # 121010053

PARTS LIST MANUAL

MODEL MS20



20" ELECTRIC POWERED MASONRY SAWS

SKU #	MODEL #	POWER OPTION
21200	MS20-5B/230/1	BALDOR ELECTRIC MOTOR 5HP 230V 1-PHASE 60HZ
21500-230	MS20-5B/230/3	BALDOR ELECTRIC MOTOR 5HP 230V 3-PHASE 60HZ
21500-460	MS20-5B/460/3	BALDOR ELECTRIC MOTOR 5HP 460V 3-PHASE 60HZ
21300-230	MS20-7.5B/230/3	BALDOR ELECTRIC MOTOR 7.5HP 230V 3-PHASE 60HZ
21300-460	MS20-7.5B/460/3	BALDOR ELECTRIC MOTOR 7.5HP 460V 3-PHASE 60HZ



A Division of Equipment Development Company, Inc.



Printed in USA

JWA ©2012

PARTS FINDER

**Search Website
by Part Number**



**Search Manual
Library For Parts
Manual & Lookup Part
Numbers – Purchase
or Request Quote**

Search Manuals

Enter your information to help us find the right parts manual for your machine.

* Brand:

* Model:

* Serial:

* Part Number:

SEARCH

**Can't Find Part or
Manual? Request Help
by Manufacturer,
Model & Description**

Parts Order Form

Please fill in the following information to help us find the right part for your machine.

Manufacturer:	<input type="text"/>
Model:	<input type="text"/>
Description:	<input type="text"/>
Part Number:	<input type="text"/>
Quantity:	<input type="text"/>
Notes:	<input type="text"/>

Submit

Discount-Equipment.com is your online resource for quality parts & equipment.

Florida: **561-964-4949** Outside Florida TOLL FREE: **877-690-3101**

Need parts?

Click on this link: <http://www.discount-equipment.com/category/5443-parts/> and choose one of the options to help get the right parts and equipment you are looking for. Please have the machine model and serial number available in order to help us get you the correct parts. If you don't find the part on the website or on one of the online manuals, please fill out the request form and one of our experienced staff members will get back to you with a quote for the right part that your machine needs.

We sell worldwide for the brands: Genie, Terex, JLG, MultiQuip, Mikasa, Essick, Whiteman, Mayco, Toro Stone, Diamond Products, Generac Magnum, Airman, Haulotte, Barreto, Power Blanket, Nifty Lift, Atlas Copco, Chicago Pneumatic, Allmand, Miller Curber, Skyjack, Lull, Skytrak, Tsurumi, Husquvarna Target, Stow, Wacker, Sakai, Mi-T-M, Sullair, Basic, Dynapac, MBW, Weber, Bartell, Bennar Newman, Haulotte, Ditch Runner, Menegotti, Morrison, Contec, Buddy, Crown, Edco, Wyco, Bomag, Laymor, EZ Trench, Bil-Jax, F.S. Curtis, Gehl Pavers, Heli, Honda, ICS/PowerGrit, IHI, Partner, Imer, Clipper, MMD, Koshin, Rice, CH&E, General Equipment, Amida, Coleman, NAC, Gradall, Square Shooter, Kent, Stanley, Tamco, Toku, Hatz, Kohler, Robin, Wisconsin, Northrock, Oztec, Toker TK, Rol-Air, APT, Wylie, Ingersoll Rand / Doosan, Innovatech, Con X, Ammann, Mecalac, Makinex, Smith Surface Prep, Small Line, Wanco, Yanmar

READ AND UNDERSTAND THE OPERATORS INSTRUCTION MANUAL THOROUGHLY BEFORE ATTEMPTING TO OPERATE THIS EQUIPMENT.



Death or serious injury could occur if this machine is used improperly.



SAFETY MESSAGES

- Safety Instructions are preceded by a graphic alert symbol of DANGER, WARNING, or CAUTION.



Indicates an imminent hazard which, if not avoided, will result in death or serious injury.



Indicates an imminent hazard which, if not avoided, can result in death or serious injury.



Indicates hazards which, if not avoided, could result in serious injury and or damage to the equipment.

GASOLINE/PROPANE POWERED EQUIPMENT



- Engine exhaust from this product contains chemicals known to the State of California to cause cancer, birth defects or other reproductive harm.



Gasoline is extremely flammable and poisonous. It should only be dispensed in well ventilated areas, and with a cool engine.

- Small gasoline engines produce high concentrations of carbon monoxide (CO) example: a 5 HP 4 cycle engine operation in an enclosed 100,000 cu. ft. area with only one change of air per hour is capable of providing deadly concentrations of CO in less than fifteen minutes. Five changes of air in the same area will produce noxious fumes in less than 30 minutes. Gasoline or propane powered equipment should not be used in enclosed or partially enclosed areas. Symptoms of CO poisoning include, headache, nausea, weakness, dizziness, visual problems and loss of consciousness. If symptoms occur - get into fresh air and seek medical attention immediately.

ELECTRICAL POWERED EQUIPMENT



Extreme care must be taken when operating electric models with water present: Ensure power cord is properly grounded, is attached to a Ground-Fault-Interrupter (GFI) outlet, and is undamaged.

- Check all electrical cables - be sure connections are tight and cable is continuous and in good condition. Be sure cable is correctly rated for both the operating current and voltage of this equipment.
- Improper connection of the equipment-grounding conductor can result in a risk of electric shock. Check with qualified electrician or service person if there is any doubt as to whether the outlet is properly grounded. Adhere to all local codes and ordinances.
- **NOTE:** In the event of a malfunction or breakdown, grounding provides a path of least resistance for the electric current to dissipate. The motor is equipped with a grounded plug and must be connected to an outlet that is properly installed and properly grounded. DO NOT modify the plug provided on the motor. If the plug does not fit the outlet have a qualified electrician install the proper receptacle.
- Switch motor OFF **before** disconnecting power.

- Do not disconnect power by pulling cord. To disconnect, grasp the plug, not the cord.
- Unplug power cord at the machine when not in use and before servicing.

GENERAL INSTRUCTIONS

- Equipment should only be operated by trained personnel in good physical condition and mental health (not fatigued). The operator and maintenance personnel must be physically able to handle the bulk weight and power of this equipment.
- This is a one person tool. Maintain a **safe operating distance** to other personnel. It is the **operators' responsibility** to keep other people (workers, pedestrians, bystanders, etc.) away during operation. Block off the work area in all directions with roping, safety netting, etc. for a **safe distance**. Failure to do so may result in others being injured by flying debris or exposing them to harmful dust and noise.
- This equipment is intended for commercial use only.
- For the operator's safety and the safety of others, always keep all guards in place during operation.
- Never let equipment run unattended.



- Personal Protection Equipment and proper safety attire must be worn when operating this machinery. The operator must wear approved safety equipment appropriate for the job such as hard hat and safety shoes when conditions require. Hearing protection **MUST** be used (operational noise levels of this equipment may exceed 90db). Eye protection **MUST** be worn at all times.



Keep body parts and loose clothing away from moving parts. Failure to do so could result in dismemberment or death.

- Do not modify the machine.
 - Stop motor/engine when adjusting or servicing this equipment.
- Maintain a safe operating distance from flammable materials. Sparks from the cutting-action of this machine can ignite flammable materials or vapors.

DUST WARNING



Some dust created by power sanding, sawing, grinding, drilling, and other construction activities contains chemicals known to cause cancer, birth defects, or other reproductive harm. Some examples of these chemicals are:

- Lead from lead-based paints, and
 - Crystalline silica from bricks and concrete and other masonry products.
- Your risk of exposure to these chemicals varies depending on how often you do this type of work. To reduce your risk: work in a well ventilated area, use a dust control system, such as an industrial-style vacuum, and wear approved personal safety equipment, such as a dust/particle respirator designed to filter out microscopic particles.

PARTS LIST MANUAL

MODEL MS20

TABLE OF CONTENTS

<u>Section</u>	<u>Page Number</u>
Safety Messages and General Instructions	2
How To Order Replacement Parts	3
Illustration 1: Main Grouping	4, 5
Illustration 2: Foot Pedal & Linkage Grouping	6, 7
Illustration 3: Main Deck & Belt Drive Grouping	8, 9
Illustration 4: Arbor Assembly	10
Illustration 5: Rolling Table Assembly	11
Illustration 6: Blade Guard & Water Pump Grouping	12, 13
Illustration 7: Motor Grouping	14, 15
Wiring Diagram for Starter & Water Pump Outlet (Single-Phase)	16
Wiring Diagram for Starter (Three-Phase)	17
Wiring Diagram for Single-Phase 60Hz Motor	18
Wiring Diagram for Three-Phase 60Hz Motor	19
Decal Sheet 1	20
Decal Sheet 2	21
Page Left Blank Intentionally	22
Notes	23
Limited Equipment Warranty of Sale - Terms & Conditions	24(BackPage)



A Division of Equipment Development Company, Inc.

ILLUSTRATION 1: MAIN GROUPING

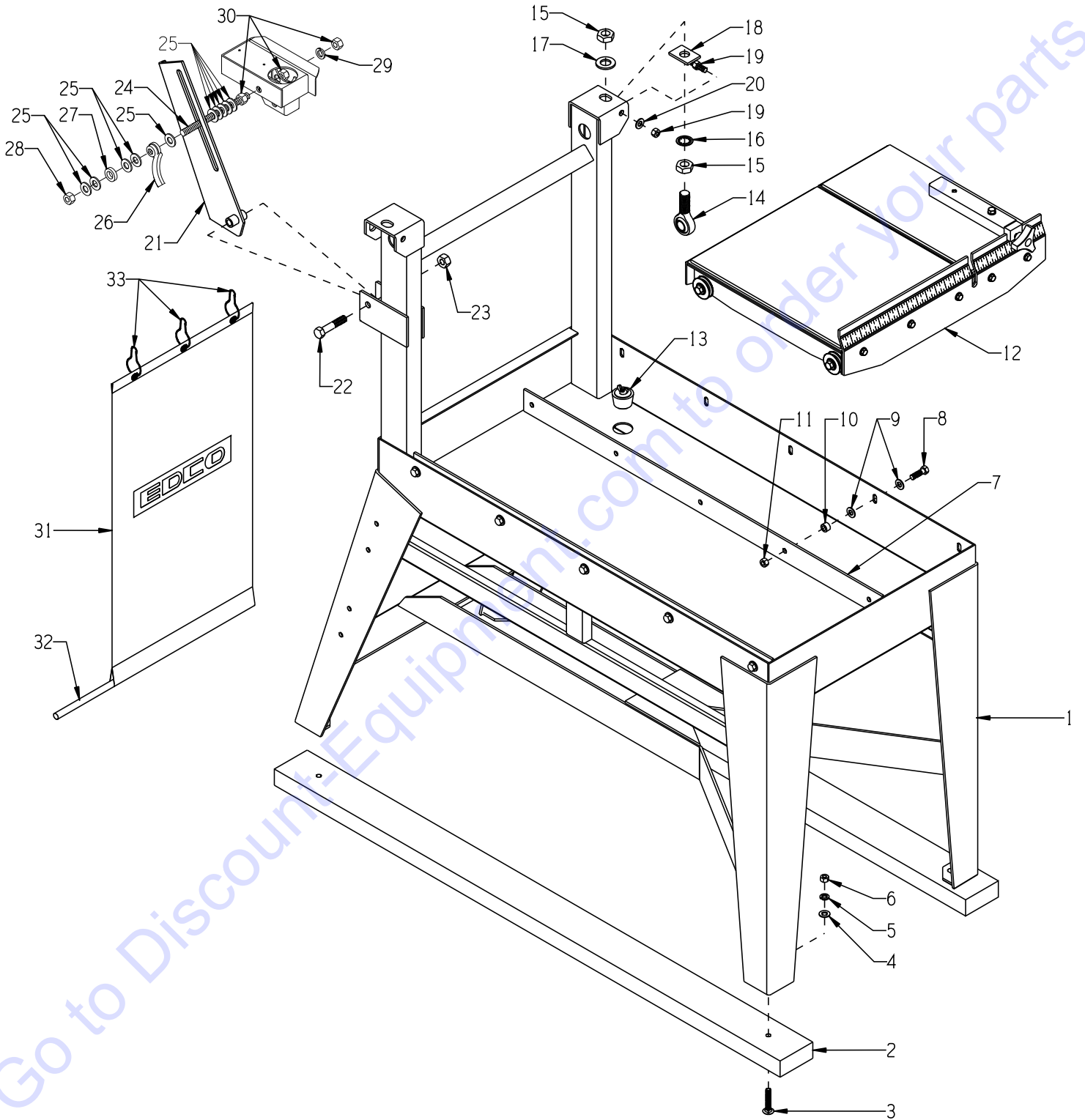

PARTS LISTING - ILLUSTRATION 1: MAIN GROUPING			
ITEM #	PART #	DESCRIPTION	QTY.
1	41106	STAND & PAN WELDMENT, MS-20	1
2	41002	SKID BOARD 2 X 4 X 54"L, GMS/MS-20	2
3	10364	BOLT, CARRIAGE 3/8-16 X 2 GRADE 5	4
4	10025	WASHER, FLAT 3/8 SAE ZINC	4
5	10811	WASHER, LOCK 3/8 ZINC	4
6	10404	NUT, HEX 3/8-16 ZINC	4
7	41003	RAIL, GUIDE, GMS/MS-20	2
8	10309	SCREW, CAP 3/8-24 X 1-1/4 ZINC	10
9	10025	WASHER, FLAT 3/8 SAE ZINC	20
10	10011	SPACER, STEEL 5/8OD X 3/8ID X 3/8T	10
11	10004	NUT, HEX LOCK 3/8-24 ZINC	10
12	41101	TABLE COMPLETE, ROLLING, MS/GMS-20 (REFER TO ILLUSTRATION 5 FOR BREAKDOWN)	1
13	40378	STOPPER ASSEMBLY 1-1/2"	1
14	10935	ROD END, MALE 3/4-16	2
15	10429	NUT, HEX JAM 3/4-16 ZINC	4
16	10609	WASHER, LOCK, INT. TOOTH 3/4"	2
17	10009	WASHER, FLAT 3/4 SAE ZINC	2
18	41107	ADJUSTER, HEAD, MS-20	2
19	10404	NUT, HEX 3/8-16 ZINC	4
20	10025	WASHER, FLAT 3/8 SAE ZINC	2
21	41021	PLATE, PIVOT LOCK, GMS/MS-20	1
22	10343	SCREW, CAP 1/2-20 X 2-1/2	1
23	10205	NUT, HEX LOCK 1/2-20 ZINC	1
24	41108	ROD, ALLTHREAD 1/2-13 X 7"L	1
25	10312	WASHER, FLAT 1/2 SAE ZINC (QTY. & SPACING MAY VARY)	10
26	40358	NUT, TAIL HANDLE 1/2-13	1
27	79035	BUSHING, RUBBER 1-1/16 X 5/8 X 1/4	1
28	10155	NUT, HEX NYLON LOCK 1/2-13 ZINC	1
29	10045	WASHER, LOCK 1/2 ZINC	1
30	10417	NUT, HEX 1/2-13 ZINC	1
31	40375	CURTAIN 15" X 28" W/ LOGO	1
32	40377	CURTAIN ROD 1/2"DIA. X 13"L	1
33	40376	HOOK, CURTAIN	3



ILLUSTRATION 2: FOOT PEDAL & LINKAGE GROUPING

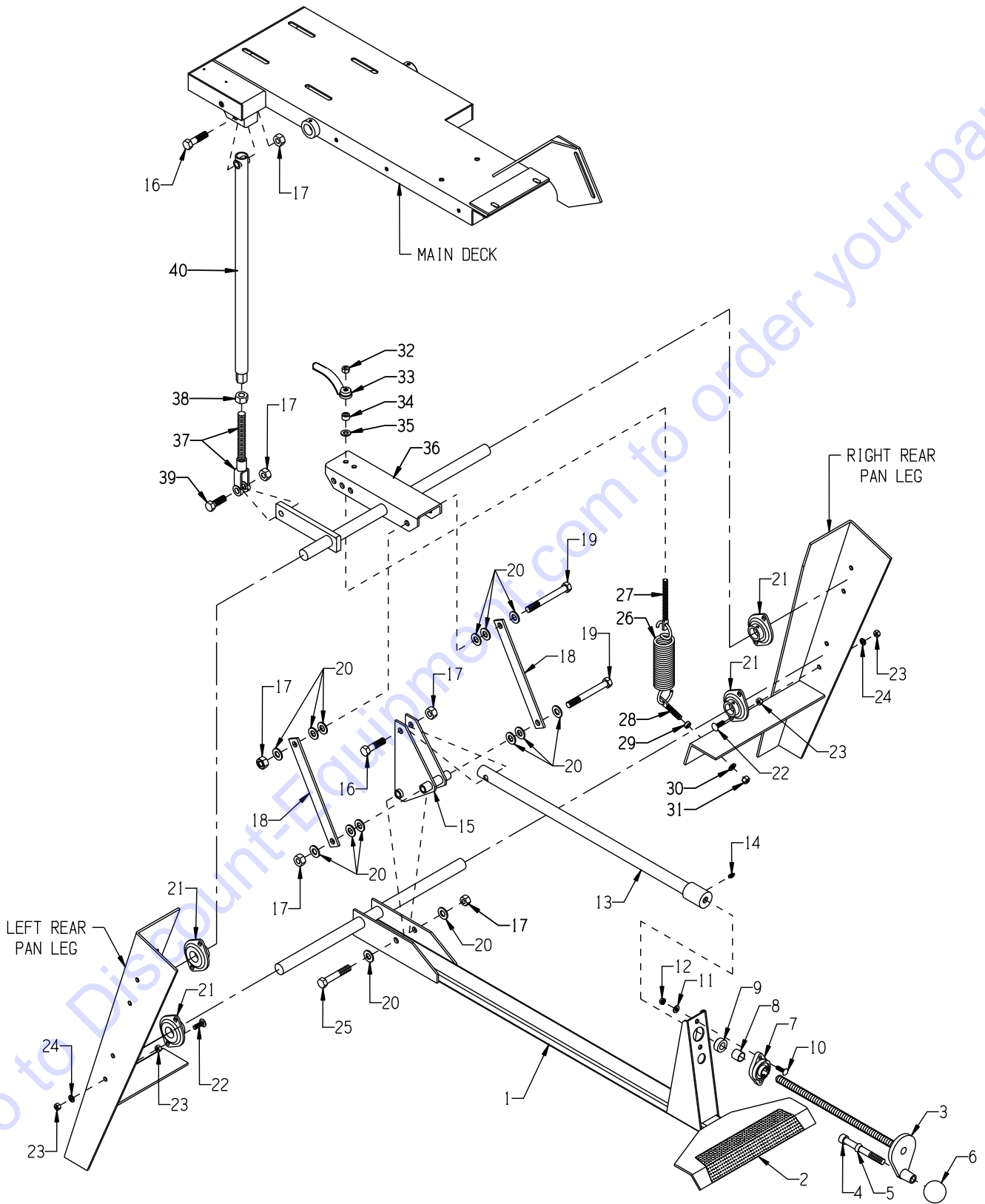

PARTS LISTING - ILLUSTRATION 2: FOOT PEDAL & LINKAGE GROUPING

ITEM #	PART #	DESCRIPTION	QTY.
1	41121	TREADLE (FOOT PEDAL) MS/GMS-20	1
2	41132	TREAD, ABRASIVE, FOOT PEDAL	1
3	41012	HANDWHEEL, SMALL W/ 5/8-8 X 15" ROD	1
4	10346	SCREW, SKT. HD. CAP 1/2-13 X 4-1/2	1
5	50550	SLEEVE, BRASS 1/2" TAPERED	1
6	10104	KNOB, BALL 1-7/8 W/ 1/2-13THD, BLK.	1
7	80009	BEARING, BALL 5/8" 2-HOLE (NO G.F.)	1
8	55010	SPACER, HANDWHEEL 5/8" ID X 3/4" L	1
9	10096	COLLAR, LOCKING 5/8" ID	1
10	10412	BOLT, CARRIAGE 1/4-20 X 1 FULL THD.	2
11	10602	WASHER, FLAT 1/4 SAE ZINC	2
12	10861	NUT, KEPS LOCK 1/4-20 ZINC	2
13	41013	LINKAGE, CUT CONTROL, GMS/MS-20	1
14	10808	FITTING, GREASE 1/4-28 STRAIGHT	1
15	41014	LINKAGE, PIVOT, MS/GMS-20	1
16	10322	SCREW, CAP 1/2-20 X 2	2
17	10205	NUT, HEX LOCK 1/2-20 ZINC	6
18	41015	LINKAGE, CONNECTING, MS/GMS-20	2
19	10409	SCREW, CAP 1/2-20 X 4-1/2	2
20	10312	WASHER, FLAT 1/2 SAE ZINC	14
21	41060	BEARING, BALL 1" 2-HOLE SHEET METAL	4
22	10819	BOLT, CARRIAGE 5/16-18 X 1 FULL THD	8
23	10054	NUT, HEX 5/16-18 ZINC	16
24	10801	WASHER, LOCK 5/16 ZINC	8
25	10202	SCREW, CAP 1/2-20 X 3	1
26	41041	SPRING, EXT. 1.75" OD X 8" L	2
27	10845	BOLT, SPADE 3/8-16 X 4-1/2	1
28	10843	BOLT, SPADE 3/8-16 X 1-5/8	1
29	10113	SPACER, STEEL 9/16 OD X 3/8 ID X 7/32	1
30	10811	WASHER, LOCK 3/8 ZINC	1
31	10404	NUT, HEX 3/8-16 ZINC	1
32	10810	NUT, HEX LOCK 3/8-16 ZINC	1
33	40044	NUT, TAIL HANDLE 3/8-16	1
34	10011	SPACER, STEEL 5/8 OD X 3/8 ID X 3/8 T	1
35	10025	WASHER, FLAT 3/8 SAE ZINC	1
36	41122	TREADLE, TRANSFER ARM, MS/GMS-20	1
37	41019	LINKAGE, CLEVIS, MS/GMS-20	1
38	10046	NUT, HEX 5/8-11 ZINC	1
39	10308	SCREW, CAP 1/2-20 X 1-1/2	1
40	41018	LINKAGE, DRAG, GMS/MS-20	1



A Division of Equipment Development Company, Inc.

Printed in USA

JWA ©2012

Page 7

ILLUSTRATION 3: MAIN DECK & BELT DRIVE GROUPING

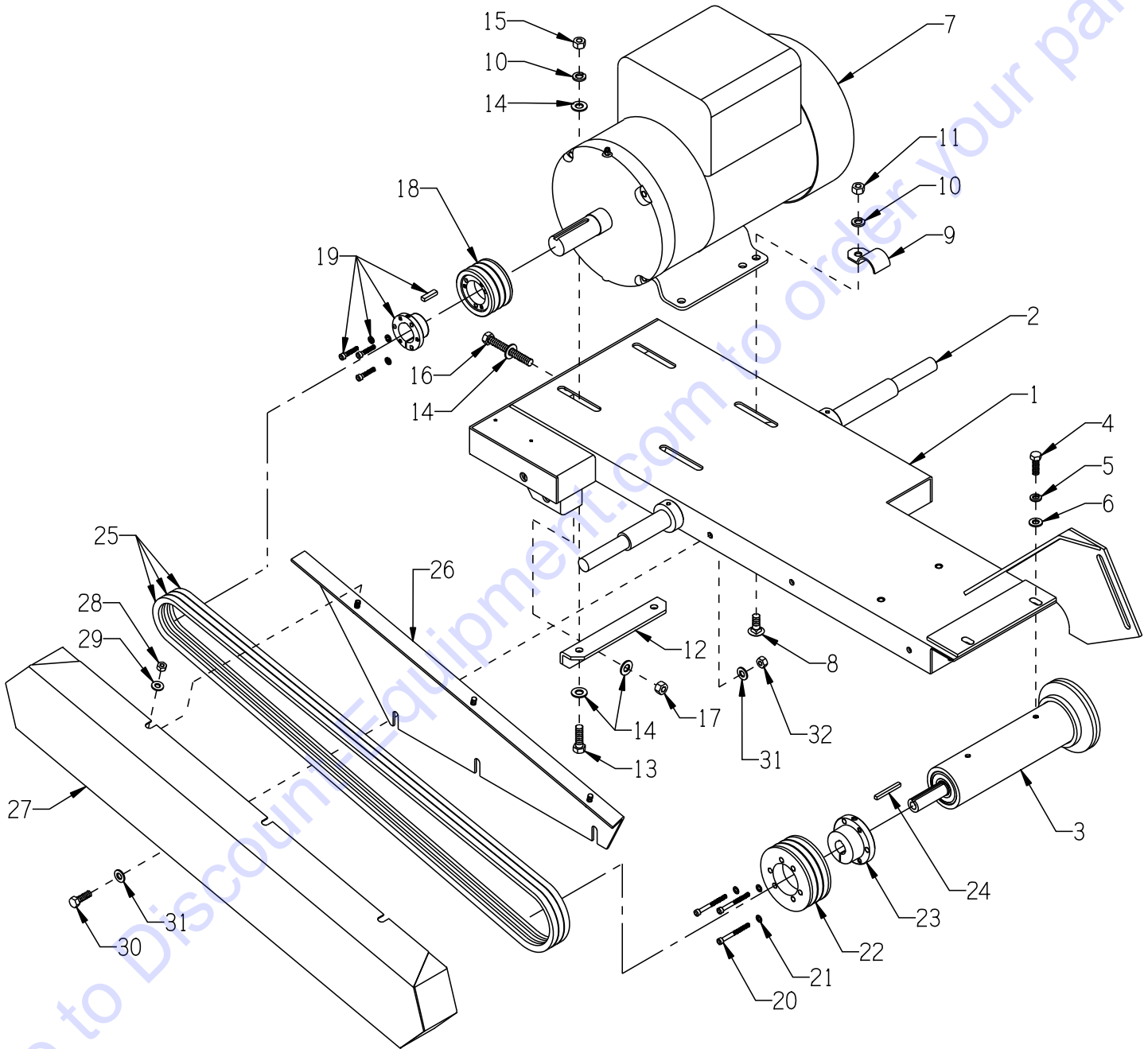

PARTS LISTING - ILLUSTRATION 3: MAIN DECK & BELT DRIVE GROUPING			
ITEM #	PART #	DESCRIPTION	QTY.
1	41112	DECK, MAIN, MS-20	1
2	41120	SHAFT, PIVOT, MS-20	1
3	41113	ARBOR ASSY. COMPLETE (REFER TO ILLUS. 4 FOR BREAKDOWN)	1
4	10332	SCREW, CAP 5/16-24 X 1	4
5	10801	WASHER, LOCK 5/16 ZINC	4
6	10213	WASHER, FLAT 5/16 SAE ZINC	4
7	-----	MOTOR (REFER TO ILLUS. 7 FOR DETAILS)	1
8	10802	BOLT, CARRIAGE 3/8-16 X 1 ZINC	2
9	41124	CLAMP, CONDUIT 1/2"PIPE (13/16")	2
10	10811	WASHER, LOCK 3/8 ZINC	4
11	10404	NUT, HEX 3/8-16 ZINC	2
12	41109	TENSIONER, MS-20	1
13	10309	SCREW, CAP 3/8-24 X 1-1/4 ZINC	2
14	10025	WASHER, FLAT 3/8 SAE ZINC	5
15	10014	NUT, HEX 3/8-24 ZINC	2
16	28025	BOLT, TAP 3/8-16 X 3 (FULL THREAD)	1
17	10156	NUT, HEX NYLON LOCK 3/8-16 ZINC	1
18	10534	SHEAVE 2.65"OD X 3GR.3V X JA	1
19	10533	BUSHING, SHEAVE JA X 1-1/8"BORE	1
20	11584	SCREW, SKT. HD. CAP 10-24 X 2	6
21	10831	WASHER, LOCK, INT. TOOTH #10	6
22	10539	SHEAVE 3.65"OD X 3GR.3V X SH	1
23	10532	BUSHING, SHEAVE SH X 3/4"BORE	1
24	10170	KEY 3/16SQ X 1-3/4	1
25	10257	BELT 3VX-630, GATES SUPER HC V (3/8" x 63")	3
26	41111	BRACKET, BELT COVER, MS-20	1
27	41110	COVER, BELT, MS-20	1
28	10861	NUT, KEPS LOCK 1/4-20 ZINC	3
29	10602	WASHER, FLAT 1/4 SAE ZINC	3
30	10053	SCREW, CAP 5/16-18 X 3/4	2
	10806	SCREW, CAP 5/16-18 X 1 (SHOWN)	1
31	10213	WASHER, FLAT 5/16 SAE ZINC	6
32	10807	NUT, HEX LOCK 5/16-18 ZINC	3



A Division of Equipment Development Company, Inc.

ILLUSTRATION 4: ARBOR ASSEMBLY

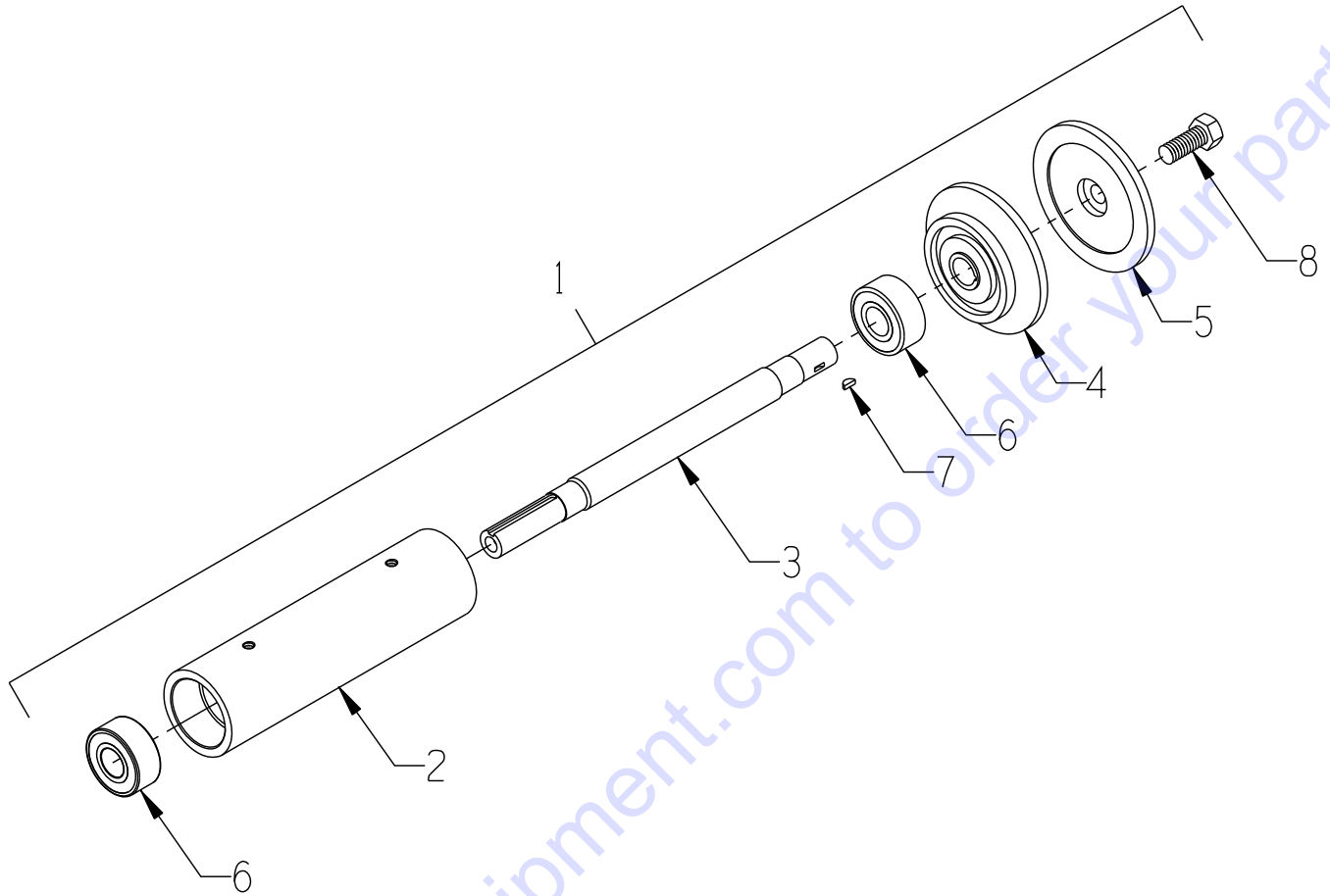

ITEM #	PART #	DESCRIPTION	QTY.
1	41113	ARBOR ASSY. COMPLETE (INCLUDES ITEMS 2 THRU 8)	1
2	41024	ARBOR HOUSING, MS/GMS-20	1
3	41025	ARBOR SHAFT 11-3/4"L, MS/GMS-20	1
4	40022	ARBOR BACKING PLATE 4", MASONRY SAW	1
5	40023	ARBOR BLADE CAP 4", MASONRY SAW	1
6	40018	BEARING, RADIAL BALL 20X47X20.6MM	2
7	40036	KEY, WOODRUFF 1/8 X 3/8 (#403)	1
8	10321	SCREW, CAP 1/2-20 X 1-1/4	1

ILLUSTRATION 5: ROLLING TABLE ASSEMBLY

E-MS20-PL-1012

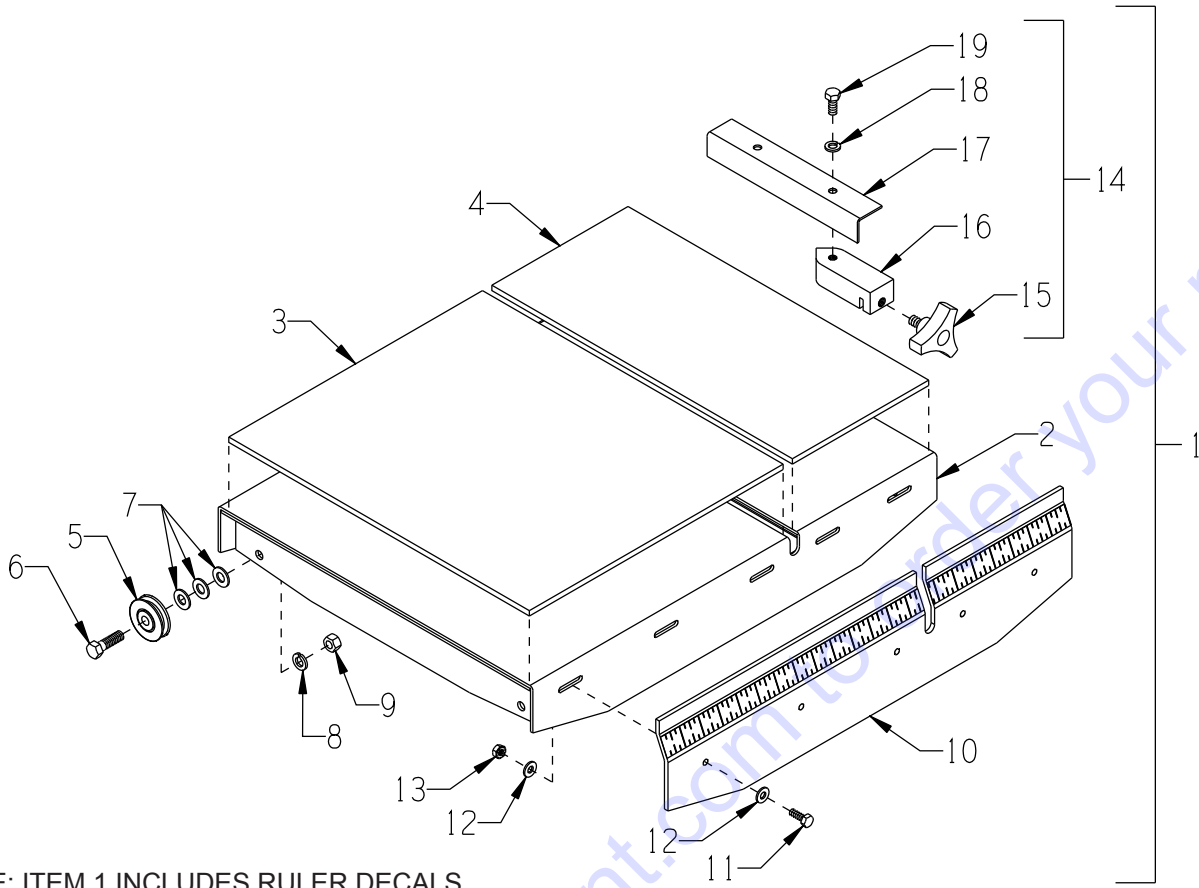

* NOTE: ITEM 1 INCLUDES RULER DECALS

ITEM #	PART #	DESCRIPTION	QTY.
1*	41101	TABLE COMPLETE, ROLLING (INCLUDES ITEMS 2 THRU 19)	1
2	41102	TABLE ONLY, ROLLING, GMS/MS-20	1
3	41006	RUBBER PAD 16 X 13-5/8 X 1/4	1
4	41007	RUBBER PAD 16 X 7-1/4 X 1/4	1
5	3621	PULLEY BEARING 1-3/4DIA. X 3/8BORE (A.K.A. TRACK WHEEL)	4
6	10816	SCREW, CAP 3/8-24 X 1-1/2	4
7	10025	WASHER, FLAT 3/8 SAE ZINC (QTY. & SPACING MAY VARY)	12
8	10811	WASHER, LOCK 3/8 ZINC	4
9	10014	NUT, HEX 3/8-24 ZINC	4
10	41103	FRONT PANEL, ROLL TABLE (NO RULER DECALS)	1
11	10018	SCREW, CAP 1/4-20 X 3/4	5
12	10602	WASHER, FLAT 1/4 SAE ZINC	10
13	10861	NUT, KEPS LOCK 1/4-20 ZINC	5
14	40689A	GUIDE ASSY., CUT, UNIVERSAL (INCL. ITEMS 15 THRU 19)	1
15	40425	KNOB, 3-PRONG W/ 3/8-16 X 5/8 STUD	1
16	42015	BLOCK, CUT GUIDE, MASONRY SAW	1
17	40689	BRACKET, CUT GUIDE, UNIVERSAL	1
18	10801	WASHER, LOCK 5/16 ZINC	1
19	10053	SCREW, CAP 5/16-18 X 3/4	1

ILLUSTRATION 6: BLADE GUARD & WATER PUMP GROUPING

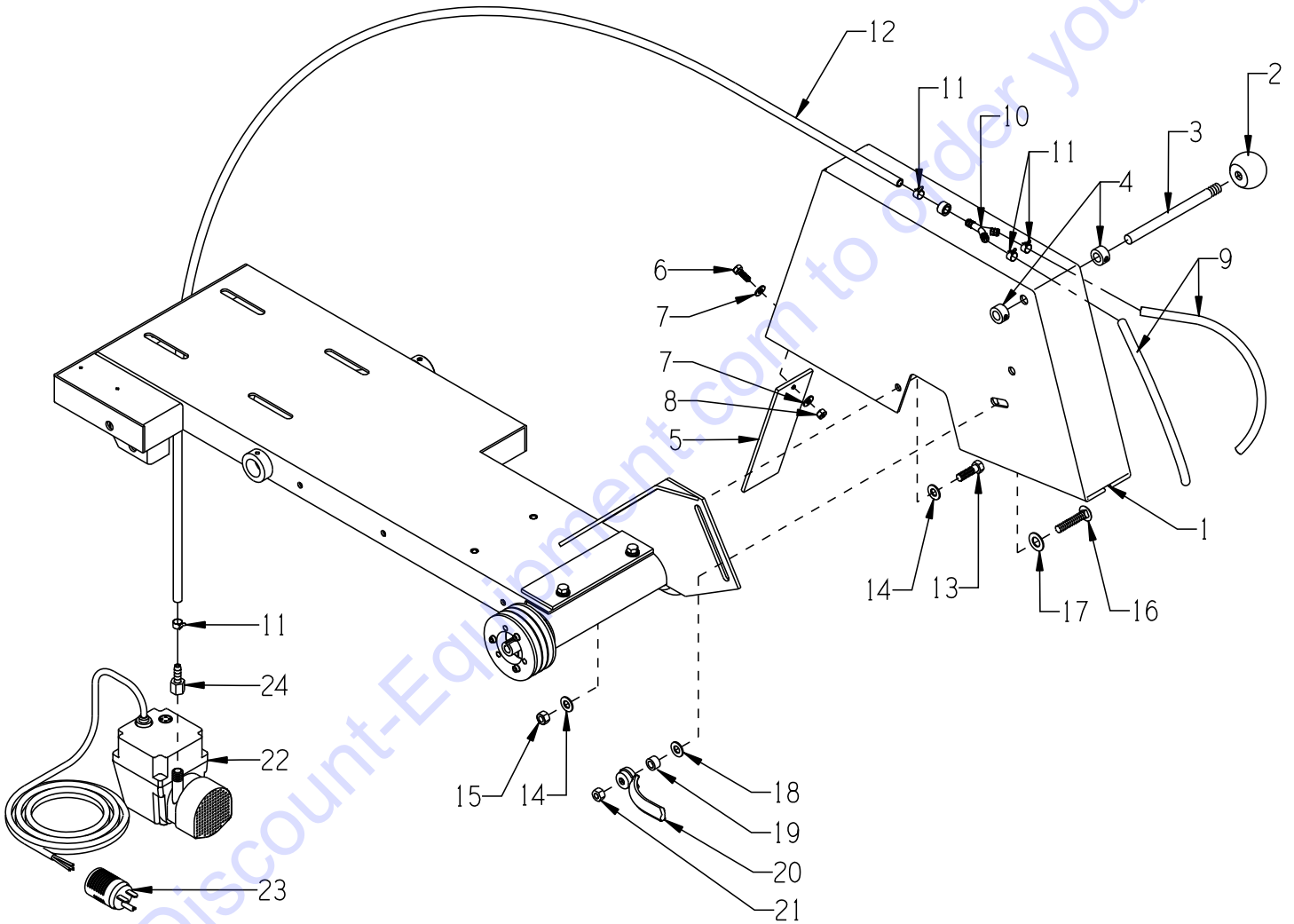

**PARTS LISTING - ILLUSTRATION 6:
BLADE GAURD & WATER PUMP GROUPING**

ITEM #	PART #	DESCRIPTION	QTY.
1	41026	GUARD, BLADE 20", MS/GMS-20	1
2	10104	KNOB, BALL 1-7/8 W/ 1/2-13THD, BLK.	1
3	41027	SHAFT, HANDLE, GMS/MS-20	1
4	10431	COLLAR, LOCKING 1/2"ID	2
5	41115	FLAP, RUBBER 2-1/2 X 8	1
6	10018	SCREW, CAP 1/4-20 X 3/4	1
7	10602	WASHER, FLAT 1/4 SAE ZINC	2
8	10015	NUT, HEX LOCK 1/4-20 ZINC	1
9	41061	HOSE 5/16"ID X 12"L, GMS/MS-20	2
10	11721	BARBED FITTING, "Y" 5/16"HOSE	1
11	10763	CLAMP, HOSE, SPRING-BAND 7/16"	8
12	41116	HOSE 5/16"ID X 50"L, MS-20	1
13	10309	SCREW, CAP 3/8-24 X 1-1/4 ZINC	1
14	10025	WASHER, FLAT 3/8 SAE ZINC	2
15	10004	NUT, HEX LOCK 3/8-24 ZINC	1
16	10364	BOLT, CARRIAGE 3/8-16 X 2 GRADE 5	1
17	10040	WASHER, GARRET 17/32 X 1 X .054	1
18	10025	WASHER, FLAT 3/8 SAE ZINC	1
19	10011	SPACER, STEEL 5/8OD X 3/8ID X 3/8T	1
20	40044	NUT, TAIL HANDLE 3/8-16	1
21	10810	NUT, HEX LOCK 3/8-16 ZINC	1
22	41117	PUMP, WATER, 230 VAC, SUBMERSIBLE	1
23	41118	PLUG, STRAIGHT 15A/250V NEMA 6-15P	1
24	10739	BARB, 5/16 HOSE X 1/4 FPT	1



A Division of Equipment Development Company, Inc.

ILLUSTRATION 7: MOTOR GROUPING

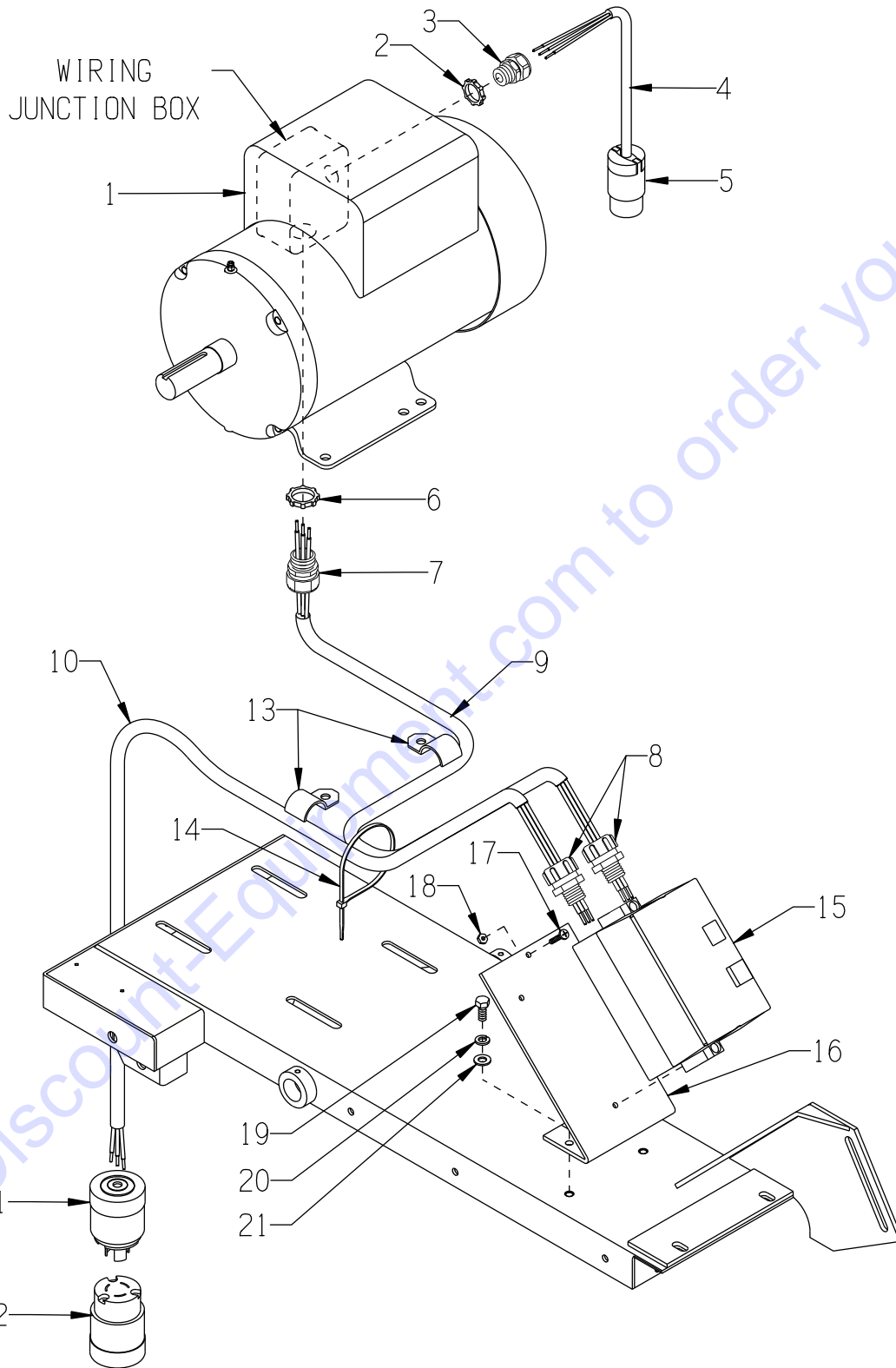

PARTS LISTING - ILLUSTRATION 7: MOTOR GROUPING

ITEM #	PART #	DESCRIPTION	QTY.
1	81026 81022 16002	MOTOR, BALDOR 5HP-1PH 60HZ 3450RPM 230V, 19.5 FLA (SHOWN) 5HP-3PH-60HZ-3450RPM 230/460V, 12/6 FLA 7.5HP-3P 60HZ 3450RPM 230/460V, 17.4/8.7 FLA	1
2*	10790	CONDUIT LOCK NUT 1/2 NP (LOCATED INSIDE WIRING BOX)	1
3*	40066	STRAIN RELIEF 1/2NPT X .350-.450"	1
4*	41129	WIRE HARNESS 16/3 X 15"LOA, MS-20	1
5*	41119	CONNECTOR, STR. 15A/250V 6-15R	1
6	10740	CONDUIT LOCK NUT 3/4 NP (LOCATED INSIDE WIRING BOX)	1
7	10605	STRAIN RELIEF 3/4NPT X .650-.750"	1
8	41053	STRAIN RELIEF 1/2NPT X .625-.750"	2
9	41125 41126	WIRE HARNESS SJOOW 300V (STARTER TO MOTOR) 10/3 X 50" (SINGLE PHASE) 10/4 X 50" (THREE PHASE)	1
10	41127 41128	WIRE HARNESS SJOOW 300V (POWER CORD) 10/3 X 50" (SINGLE PHASE) 10/4 X 50" (THREE PHASE)	1
11*	40037	PLUG, LOCKING 20A/250V L6-20P (SINGLE PHASE ONLY)	1
12*	40000	CONNECTOR, LOCKING 20A/250V L6-20C (SINGLE PHASE ONLY)	1
13	41124	CLAMP, CONDUIT 1/2"PIPE (13/16")	2
14	10982	TIE, CABLE, BLACK NYLON 11-1/4"	3
15	16410 16405 16406 16408 16617 16618 16622 16623 16632 16633 16635 16637	STARTER ACI #128826 200/240V COIL 17.5-21.5A O/L STARTER ACI #128841 200/240V COIL 11.3-16A O/L STARTER ACI #128847 440/480V COIL 5.5-7.5A O/L STARTER ACI #128848 440/480V COIL 7.2-10A O/L REPLACEMENT PARTS: STARTER CONT./COIL ACI SK18.310-230 STARTER CONT./COIL ACI SK18.310-460 STARTER AC COIL 200/240V-60HZ STARTER AC COIL 440/480V-60HZ STARTER OVERLOAD RELAY 5.5-7.5 AMP STARTER OVERLOAD RELAY 7.2-10.0 AMP STARTER OVERLOAD RELAY 11.3-16.0 AMP STARTER OVERLOAD RELAY 17.5-21.5 AMP	1 1 1 1 1 1 1 1 1 1 1 1
16	41134	MOUNT, ACI STARTER, MS-20	1
17	11732 10384	SCREW, MACHINE 10-32 X 1-3/4 RHP SCREW, MACHINE 10-32 X 1 RHP	2 1
18	10832	NUT, KEPS LOCK 10-32 ZINC	3
19	10053	SCREW, CAP 5/16-18 X 3/4	2
20	10801	WASHER, LOCK 5/16 ZINC	2
21	10213	WASHER, FLAT 5/16 SAE ZINC	2

*NOTE: THESE ITEMS ARE NOT INCLUDED ON THREE-PHASE UNITS.



A Division of Equipment Development Company, Inc.

WIRING DIAGRAM FOR 1-PHASE STARTER WITH WATER PUMP OUTLET

60 HERTZ

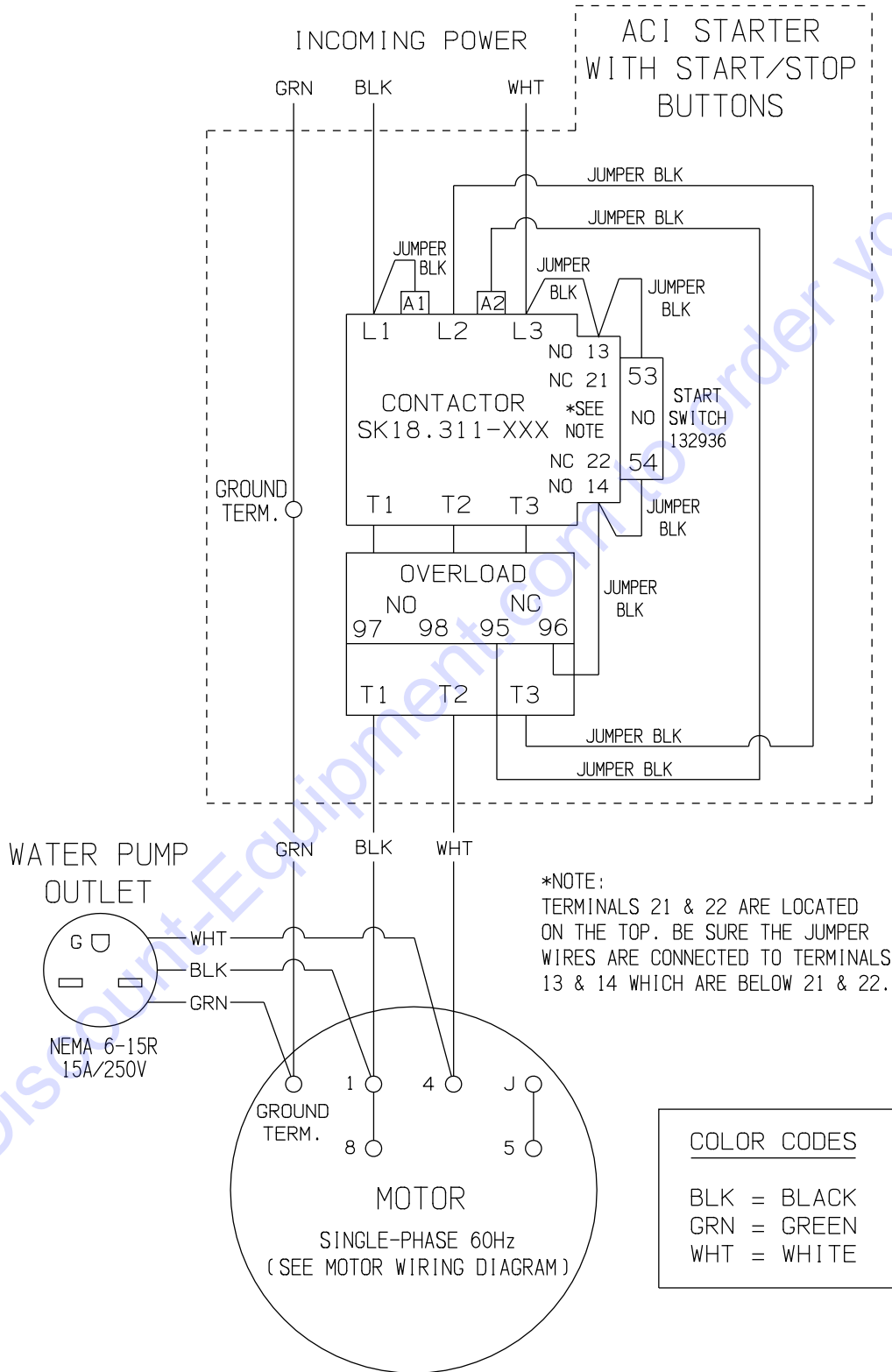

WIRING DIAGRAM FOR 3-PHASE STARTER

60 HERTZ

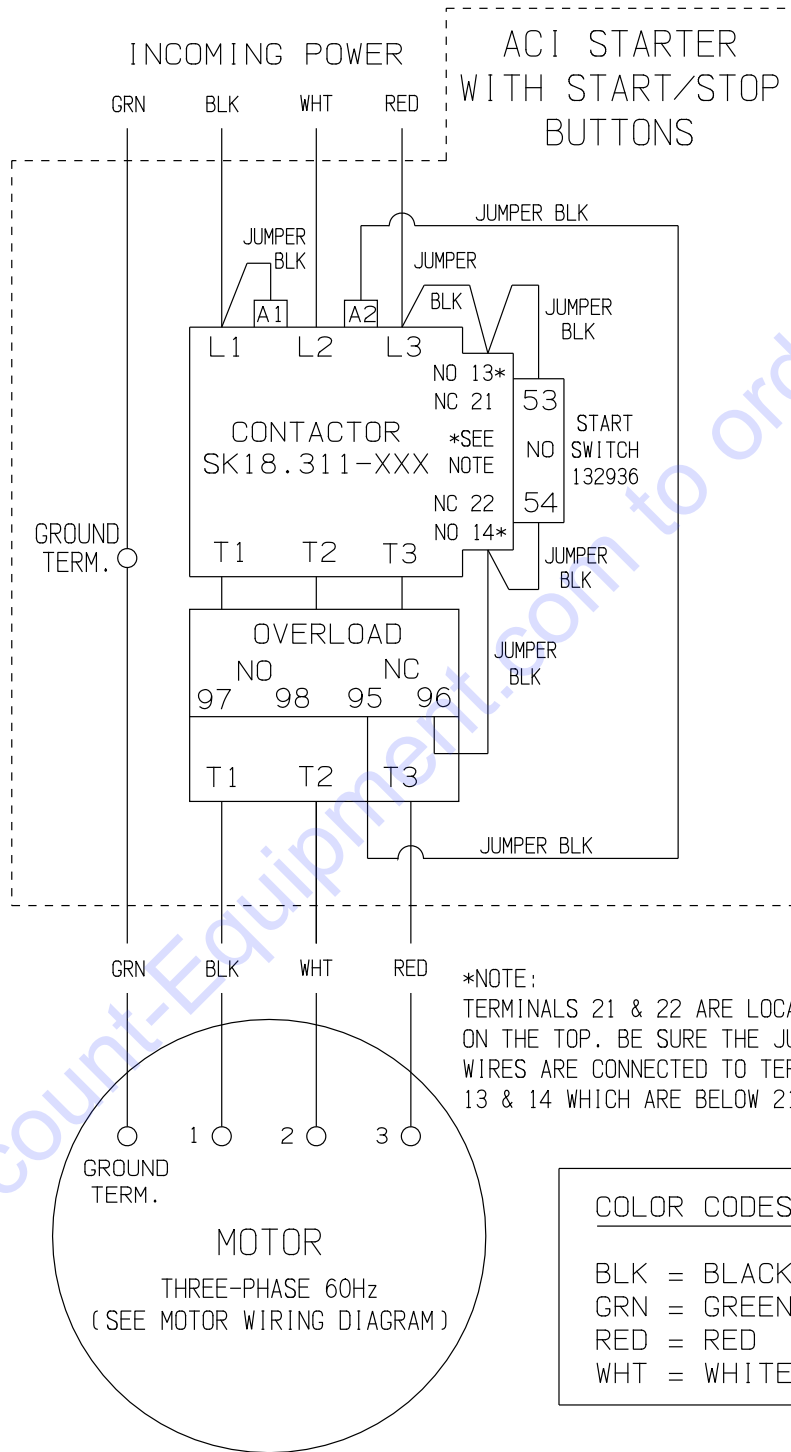

WIRING DIAGRAM FOR SINGLE-PHASE 60Hz MOTOR

5HP BALDOR CAT. NO. L3608TM

CD0002A02

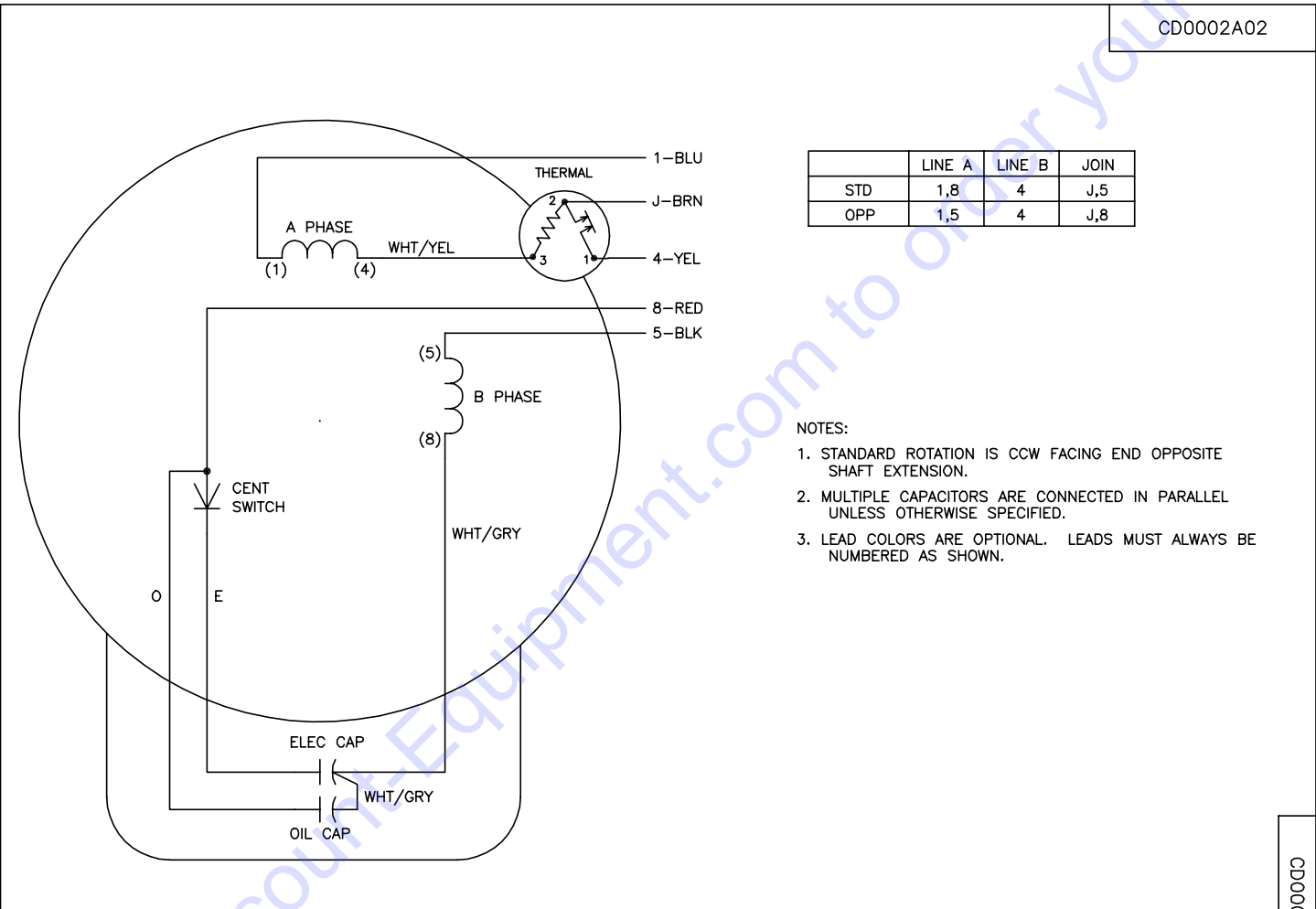

REV. DESC: REMOVE 2-TERMINAL THERMAL DETAIL, SEE CD0002A04		
REV. LTR: D	VERSION: 01	TDR: 000000360649
CD0002A02	FILE: \AAA\00007\520	REVISED: 17:11:40 04/15/2005
	MTL: -	BY: ENJOEPO

BALDOR ELECTRIC Co.

TYPE LC, SV, REV, THERMAL, 5 LEADS

CD0002A02



WIRING DIAGRAM FOR THREE-PHASE 60Hz MOTOR

5HP BALDOR CAT. NO. EM3613T
 7.5HP BALDOR CAT. NO. EM3616T

CD0005

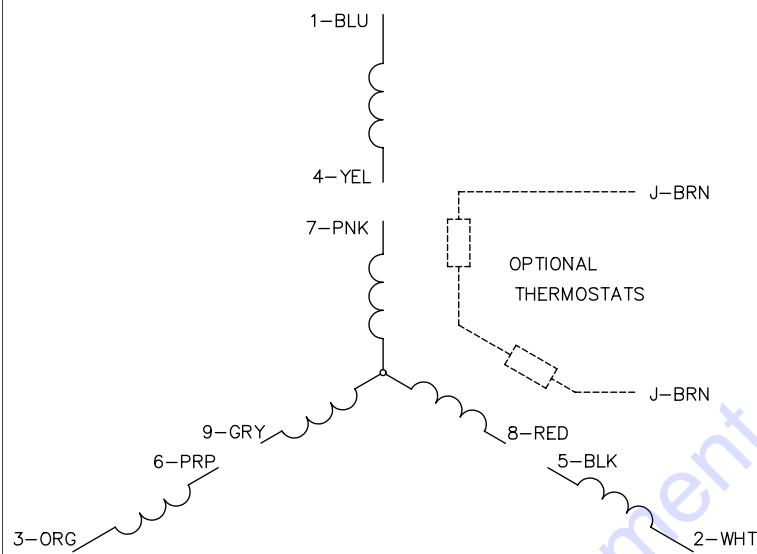

LOW VOLTAGE
(2Y)

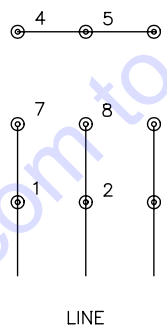

HIGH VOLTAGE
(1Y)

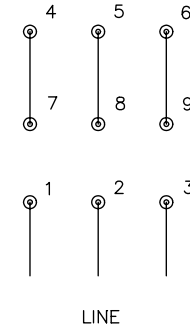

NOTES:

1. INTERCHANGE ANY TWO LINE LEADS TO REVERSE ROTATION.
2. OPTIONAL THERMOSTATS ARE PROVIDED WHEN SPECIFIED.
3. ACTUAL NUMBER OF INTERNAL PARALLEL CIRCUITS MAY BE A MULTIPLE OF THOSE SHOWN ABOVE.
4. LEAD COLORS ARE OPTIONAL. LEADS MUST ALWAYS BE NUMBERED AS SHOWN.

REV. DESC: REVISE TO SHOW OPTIONAL COLORS			
REV. LTR: E	BY: JLP	REVISED: 01/19/99 10:15	TDR: 0171435
CD0005		FILE: AAA00005140	MDL: -
		MTL: -	

BALDOR ELECTRIC Co.

3PH, DV, 9 LEADS

CD0005

PARTS FINDER

**Search Website
by Part Number**



**Search Manual
Library For Parts
Manual & Lookup Part
Numbers – Purchase
or Request Quote**

Search Manuals

Enter your information to help us find the right parts manual for your machine.

* Brand:

* Model:

* Serial:

* Part Number:

SEARCH

**Can't Find Part or
Manual? Request Help
by Manufacturer,
Model & Description**

Parts Order Form

Please fill in the following information to help us find the right part for your machine.

Manufacturer:	<input type="text"/>
Model:	<input type="text"/>
Description:	<input type="text"/>
Part Number:	<input type="text"/>
Quantity:	<input type="text"/>
Notes:	<input type="text"/>

Discount-Equipment.com is your online resource for quality parts & equipment.

Florida: **561-964-4949** Outside Florida TOLL FREE: **877-690-3101**

Need parts?

Click on this link: <http://www.discount-equipment.com/category/5443-parts/> and choose one of the options to help get the right parts and equipment you are looking for. Please have the machine model and serial number available in order to help us get you the correct parts. If you don't find the part on the website or on one of the online manuals, please fill out the request form and one of our experienced staff members will get back to you with a quote for the right part that your machine needs.

We sell worldwide for the brands: Genie, Terex, JLG, MultiQuip, Mikasa, Essick, Whiteman, Mayco, Toro Stone, Diamond Products, Generac Magnum, Airman, Haulotte, Barreto, Power Blanket, Nifty Lift, Atlas Copco, Chicago Pneumatic, Allmand, Miller Curber, Skyjack, Lull, Skytrak, Tsurumi, Husquvarna Target, Stow, Wacker, Sakai, Mi-T-M, Sullair, Basic, Dynapac, MBW, Weber, Bartell, Bennar Newman, Haulotte, Ditch Runner, Menegotti, Morrison, Contec, Buddy, Crown, Edco, Wyco, Bomag, Laymor, EZ Trench, Bil-Jax, F.S. Curtis, Gehl Pavers, Heli, Honda, ICS/PowerGrit, IHI, Partner, Imer, Clipper, MMD, Koshin, Rice, CH&E, General Equipment, Amida, Coleman, NAC, Gradall, Square Shooter, Kent, Stanley, Tamco, Toku, Hatz, Kohler, Robin, Wisconsin, Northrock, Oztec, Toker TK, Rol-Air, APT, Wylie, Ingersoll Rand / Doosan, Innovatech, Con X, Ammann, Mecalac, Makinex, Smith Surface Prep, Small Line, Wanco, Yanmar