

# ANSI A92.20 Articulating Boom Lifts



## Standard Configurations

- Overload Sensor and Alarm
- Tilt/Slope Sensors and Alarm
- Self-closing Gate
- Lanyard Points
- Descent Protection and Alarm
- Full Height Drive
- Intelligent Diagnostic System
- AC Platform Power (GFCI)
- Proportional Control
- Wind Rating Stickers

**Discount  
Equipment**

[www.Discount-Equipment.com](http://www.Discount-Equipment.com)

**LGMG North America Inc.**



# DEUTZ DIESEL MOTOR DRIVE

## AR52J Articulating Boom Lift (Indoor/Outdoor)

- Engine powered machines offer outstanding performance for traveling over rough surfaces
- Compact design with zero tail swing and a tight turning radius enables easy access to narrow aisles and restrictive jobsites
- Proportional control ensures precise positioning and smooth driving
- Simultaneous multi-functions improve operational flexibility



Product Specifications	AR52J
Platform Capacity	510 lbs
Platform Occupants (Indoor/Outdoor)	2/2
Platform Height (Full Extension)	52'
Horizontal Outreach	30' 10"
Up and Over Height	24' 10"
Machine Length	25' 3"
Machine Width	7' 6"
Machine Height (Stowed)	7' 2"
Wheelbase	6' 8"
Ground Clearance - Center	1' 2"
Ground Clearance - Lowest Point	10"
Platform Size	71" x 31"
Platform Rotator	160°
Drive Speed (Lowered)	4.5 Mph
Drive Speed (Elevated Max Height)	0.5 Mph
Drive Mode	4x4
Gradeability (2WD)	45%
Power Source	Deutz D2.9L4
Tire Size	315/55D20
Turntable Type	Non-Continuous
Turning Radius (Inside)	6' 4"
Turning Radius (Outside)	14' 6"
Machine Weight	18,304 lbs

ANSI A92.20 Compliant

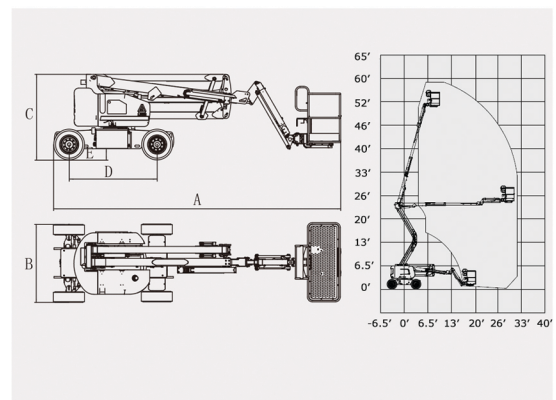

LGMG North America Inc.

**Discount  
Equipment**

[www.Discount-Equipment.com](http://www.Discount-Equipment.com)