



www.Discount-Equipment.com

600CM

600CM-PL



Steel Drum Concrete Mixer

Includes Model Number 600CM & 600CM-PL



TO PURCHASE THIS PRODUCT PLEASE CONTACT US



**Equipment Financing and
Extended Warranties Available**



**Discount-Equipment.com is your online resource for
commercial and industrial quality parts and equipment sales.**

561-964-4949

visit us on line @ www.discount-equipment.com

Select an option below to find your Equipment

Search by Manufacturer

Search by Product Type

Request a Quote

We sell worldwide for the brands: Genie, Terex, JLG, MultiQuip, Mikasa, Essick, Whiteman, Mayco, Toro Stone, Diamond Products, Generac Magnum, Airman, Haulotte, Barreto, Power Blanket, Nifty Lift, Atlas Copco, Chicago Pneumatic, Allmand, Miller Curber, Skyjack, Lull, Skytrak, Tsurumi, Husquvarna Target, Stow, Wacker, Sakai, Mi-T-M, Sullair, Basic, Dynapac, MBW, Weber, Bartell, Bennar Newman, Haulotte, Ditch Runner, Menegotti, Morrison, Contec, Buddy, Crown, Edco, Wyco, Bomag, Laymor, EZ Trench, Bil-Jax, F.S. Curtis, Gehl Pavers, Heli, Honda, ICS/PowerGrit, IHI, Partner, Imer, Clipper, MMD, Koshin, Rice, CH&E, General Equipment, Amida, Coleman, NAC, Gradall, Square Shooter, Kent, Stanley, Tamco, Toku, Hatz, Kohler, Robin, Wisconsin, Northrock, Oztec, Toker TK, Rol-Air, APT, Wylie, Ingersoll Rand / Doosan, Innovatech, Con X, Ammann, Mecalac, Makinex, Smith Surface Prep, Small Line, Wanco, Yanmar

INTRODUCTION

This owner's manual provides the information needed to operate and maintain MARSHALLTOWN's 600CM & 600CM-PL Mixers. Carefully read and follow all safety and operating instructions in this manual. Also, be sure every operator of this mixer reads this manual before operating the mixer. The replacement of any part on this mixer by parts other than the manufacturer's authorized replacement parts may adversely affect the performance, durability, warranty or safety of the product.

Be sure safety precautions are observed. Read and follow all safety and operating instructions in this operator's manual. The manufacturer reserves the right to make changes on, or add improvements to its product at any time without prior notice or obligation. The manufacturer reserves the right to decide, upon its sole discretion and at any time, to discontinue a product.

Information regarding operation and maintenance of the engine can be found in a separate engine manual supplied with this mixer if the mixer is supplied with an engine. The engine manual provides all the information required regarding engine adjustments, operation and maintenance. Should any questions arise concerning engine operation or service, contact the nearest engine repair facility or the engine manufacturer.

TABLE OF CONTENTS

Safety Precautions	3-4
Safety Decals	4
Warranty	5
Product Operation	6-7
Parts Breakdown	8-14

SAFETY PRECAUTIONS

This is the industry's safety alert symbol. This symbol calls attention to items or operations that could be dangerous. This symbol can be found throughout this manual and on safety decals on the mixer. Read these messages carefully.



CAUTION!

THE FOLLOWING PRECAUTIONS ARE SUGGESTED TO HELP PREVENT ACCIDENTS. A CAREFUL OPERATOR IS THE BEST OPERATOR. MOST ACCIDENTS CAN BE AVOIDED BY OBSERVING CERTAIN PRECAUTIONS. READ AND TAKE THE FOLLOWING PRECAUTIONS BEFORE OPERATING THIS EQUIPMENT TO HELP PREVENT ACCIDENTS. EQUIPMENT SHOULD BE OPERATED ONLY BY THOSE WHO ARE RESPONSIBLE AND INSTRUCTED TO DO SO.

1. Read all operating and maintenance instructions before operating or servicing mixer. Test run empty prior to actual use.
2. A mixer is only as safe as its operator. Give complete and undivided attention to the operation of the mixer.
3. Know how to stop the mixer and the engine instantly.
4. Always have all guards and safety devices attached and in place before operating mixer. Close engine housing during operation.
5. Keep inexperienced and unauthorized people away from the mixer at all times.
6. Never leave the mixer unattended while it is running.
7. Shut off engine or disconnect the electric motor before making any adjustments or putting hands or tools in the drum.

SAFETY PRECAUTIONS CONTINUED



Never reach into the drum or place tools into the drum while the mixer is running

8. Do not overfill the drum. Do not exceed the mixer's rated capacity.
9. Do not smoke while refueling the engine. Shut off the engine and allow it to cool before refueling. Do not spill fuel.
10. Block/chock mixer wheels when mixing.
11. Use safety chains while towing mixer.
12. Keep the mixer in good operating condition. Loose or damaged parts are dangerous.
13. Avoid loose clothing that could get caught in moving parts or on control levers.



Keep hands and feet away from moving parts

14. Do not add material to the drum while stopped. Start the drum before adding material.
15. Keep all warning, caution and safety instruction labels in good condition. Replace missing, damaged or illegible labels.

TOWING & SAFETY CHAINS

For transporting the mixer, slide the tow pole out as far as possible and insert the locking pin. Make sure drum is locked in position and engine housing is closed and secured; cross the safety chains under the tow pole and fasten them to the tow vehicle. (fig.1) When operating the mixer, slide the tow pole in and lock it in place.

NOTE! Safety chain length may need to be altered for proper connection to tow vehicle. Reposition the hooks, DO NOT cut chain.

Allow enough slack to permit proper vehicle turning while keeping chains snug enough to prevent tow pole from contacting the ground in case the hitch uncouples.

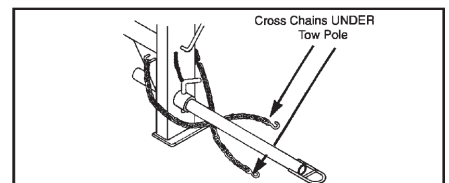

FIGURE 1

SAFETY DECALS (if applicable)

If your safety and operating decals are damaged, they can be replaced by contacting Customer Service

WS1065



WS1065

WS1066

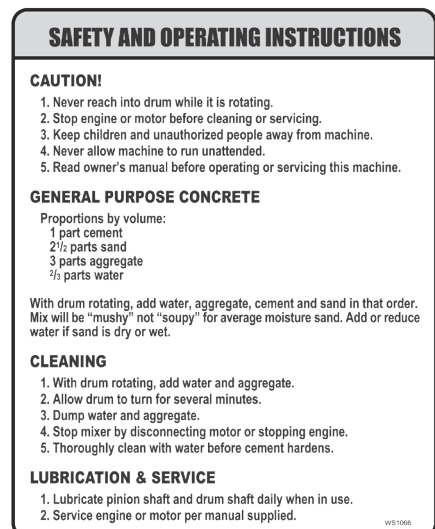

WS1066

MIXERS ONE-YEAR WARRANTY

This product is warranted to the original purchaser only, to be free of defects in material and workmanship under normal use, for one year from purchase date. Marshalltown Company shall without charge for parts and labor, repair or replace such parts which are found to be defective. All transportation charges for replacement parts must be borne by the purchaser.

For warranty service, the product must be delivered, with proof of purchase date, to the dealer of original purchase, or any factory authorized service dealer.

If difficulty is encountered in having warranty work performed, contact the factory Service Department.

All implied warranties, including those of merchantability and fitness for a particular purpose, are limited to one year from date of purchase by the original retail customer and to the extent permitted by law any and all implied warranties are excluded and disclaimed after the expiration of such period.

Some states do not allow limitations on how long an implied warranty lasts, or the exclusion or limitations of incidental or consequential damages, so the above limitations or exclusions may not apply to you. This warranty gives you specific legal rights, and you may also have other rights, which vary from state to state.

Exclusion from this warranty:

1. The following items are not covered under the Marshalltown Company one year warranty and are warranted by their respective manufacturer.
 - a) Engines, including starters, generators, alternators and gear reducers
 - b) Hydraulic components, including pumps, motors and valves
2. All consequential damages, including pickup and delivery of the unit, communication, mileage charges and/or rental of a replacement unit during repairs are not covered under this warranty, nor are any loss of income and/or other loss resulting from the failure of the product to function due to a warranty defect.
3. This warranty will not apply when the product becomes inoperative due to misuse, normal wear, neglect, improper maintenance, accident or freight damage, has not been operated and maintained in accordance with the instructions furnished in the Operator's Manual, or has been altered or modified without approval from the factory Service Department.
4. No parts or products are to be returned to the factory without prior written approval from the factory.

NOTICE: Record the model and serial numbers in the spaces provided.

Product Model Number: _____

Product Serial Number: _____

Engine/Motor Model Number: _____

Engine/Motor Code Number: _____

Purchase Date: _____

Dealer Purchased From: _____

Dealer Address: _____

Dealer Phone Number: _____

PRIOR TO START UP

1. Examine the mixer carefully to make sure there was no damage during shipment or since the last use. Report any damage immediately to the transportation company. Repair any damage before using the mixer.
2. Check the engine oil. Fill as required. Refer to the engine manual for oil specifications.
3. Fill the fuel tank with fresh, clean fuel. Refer to the engine manual for fuel specifications.
4. Grease all fittings as called out in the lubrication specifications.
5. Check for free rotation of the mixer drum yoke by rotating the drum through one complete dump-charge-dump cycle. Make sure no foreign objects or tools are in the drum before starting the motor.
6. Start the motor and check for smooth operation of the drum, ring gear, and pinion.

Note: After initial 10 hours of operations, check chain/belts for proper tension and sprockets/pulleys for alignment. Check these items monthly to prevent premature wear/failure.

LUBRICATION

Use lithium based grade 2 multi-purpose grease.

Drum Shaft Tube:

Drum shaft lubrication can be performed by removing the 1/8" pipe plug and installing the appropriate grease fitting. Greasing should be done yearly.

Yoke Bearing Hangers:

Yoke bearing hangers are located on the yoke ends and are equipped with grease fittings. These bearings should be greased weekly.

Wheel Bearings:

Grease wheel bearings once per year. Thoroughly remove old grease from bearings and spindle before repacking. Pack bearings $\frac{1}{2}$ to $\frac{2}{3}$ full to prevent overheating.

Drum Tilt Brake Bearing:

The brake bearing casting is located near the front of the mixer and should be greased weekly.

Handwheel Bearing:

The handwheel hub bearing is located on the front of the mixer, behind the handwheel. This bearing should be greased weekly.

WARNING: DO NOT GREASE BRAKE BAND OR OUTER BRAKING SURFACE OF TILT GEAR.

Jack Shaft Bearings:

Pillow block style bearings are used on the drive train counter shaft. These bearings should be greased weekly.

Drive Chain:

The drive chain should be lubricated monthly with SAE #20 or SAE #30 oil. Apply the oil between the side plates.

Engine/Motor:

Refer to the manufacturer's engine or motor operating instructions for all maintenance and lubrication requirements and instructions.

LUBRICATION FREQUENCY CHART

ITEM	FREQUENCY	LUBRICANT	PLACES
Drum Shaft Tube	yearly	grease	1
Yoke Bearing Casting	weekly	grease	2
Wheel Bearings	yearly	grease	2
Drum Tilt Brake Bearing Casting	weekly	grease	1
Handwheel Hub	weekly	grease	1
Drive Shaft	weekly	grease	1
Jackshaft (Electric motor only)	weekly	grease	2
Drive Chain	monthly	oil	1

STORAGE

For short term storage, clean the mixer and store in a dry place. If the mixer is not to be used for an extended period of time, service mixer completely and store it in a dry place.

1. Refer to motor/engine instructions for storage instructions.
2. Cover exposed metal surfaces with a thin coat of SAE 30 engine oil.
3. Lubricate per instructions under LUBRICATION section.

GETTING READY FOR MIXING

Lay out forms for your concrete floor, patio, driveway, sidewalk, etc. The quality of concrete is directly related to the quality of the cement paste. Calculate the proportions of your mix components (cement, sand and coarse aggregate) according to the job specifications.

LOADING THE MIXER

Start the mixer. Refer to motor/engine instructions. After drum has started rotating, pour about half of the water in the drum.

NOTE: The drum may leak slightly when first used. This will stop after a few batches. Add aggregate (gravel) first then cement second and sand last. Then add remaining water as needed.

MIXING INSTRUCTIONS

1. Start the drum rotating.
2. Add $\frac{1}{2}$ water.
3. Add cement and one shovelful of coarse aggregate. The coarse aggregate will break up any lumps in the cement.
4. Add remaining aggregate: crushed stone, pit-run gravel or sand.
5. Add remaining water as needed.
6. Mix batch for approximately one minute. Drum speed should be about 25 r.p.m. (NOTE: Mixing times may change.)

UNLOADING THE MIXER

Allow the entire mixture to mix for one full minute. Do not stop mixer from rotating.

Hold the tilt handle and unlock the stop lever. Dump concrete to either side by tilting the tilt handle in the direction required. (NOTE: Mixing times may change.)

EXTENSION CORDS-ELECTRIC MOTOR

The following size extension cords should be used for this mixer: length of cord, up to 100 ft-14 gauge wire; up to 200 ft-12 gauge wire; up to 300 ft – 10 gauge wire; up to 400 ft – 8 gauge wire.

CARE OF MIXER

It is important to keep the inside of the mixing drum free of hardened concrete. After discharging the last batch of concrete each day, add a pailful of water and two shovelfuls of gravel to the drum. This will scour the inside of the drum. Mix for about two minutes, discharge and rinse the drum with water. Never permit concrete to harden on either the inside or outside of drum.

TILT / LOCK MECHANISM

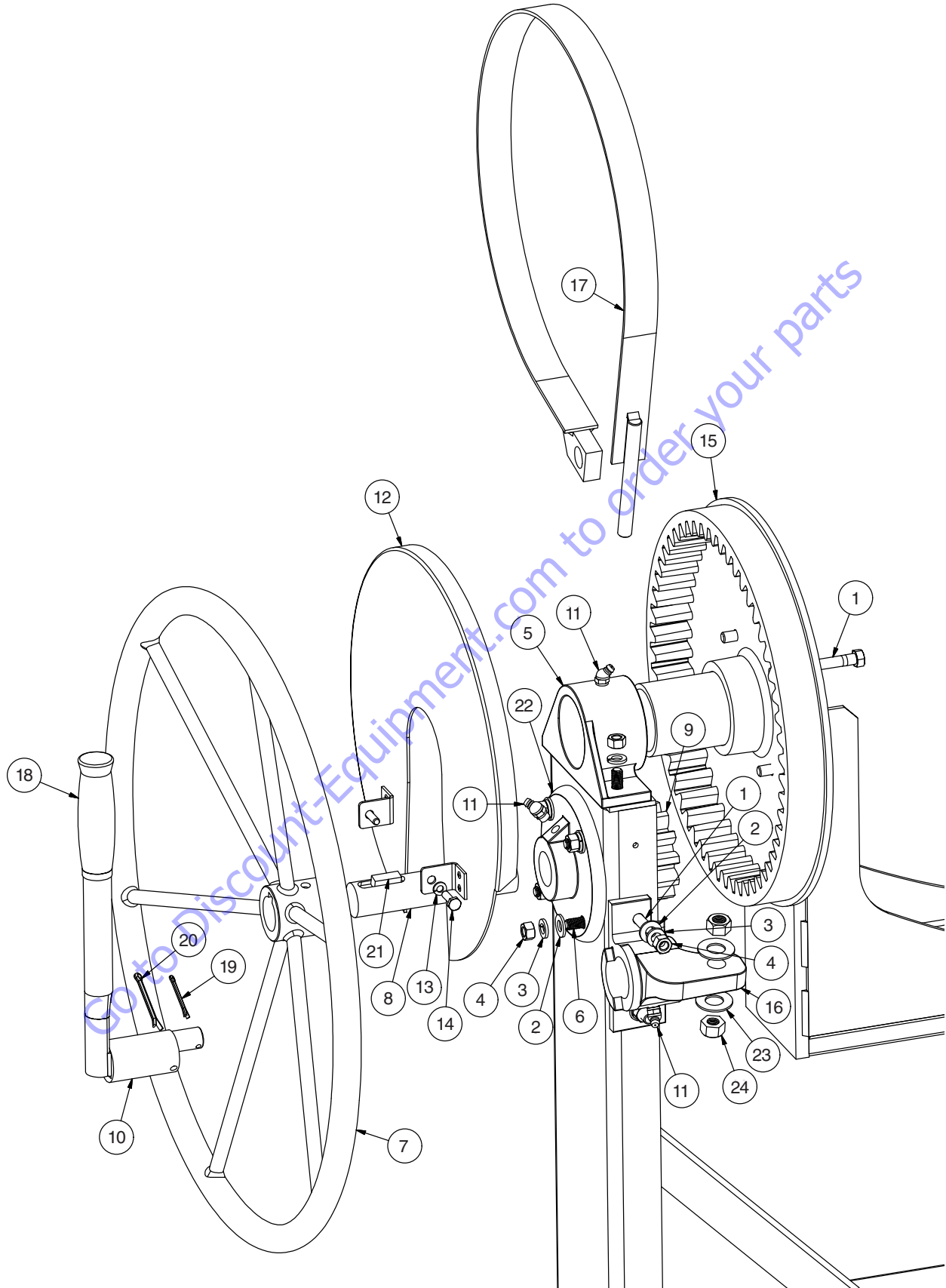

TILT / LOCK MECHANISM PARTS BREAKDOWN

REF #	NAME	PART #	QTY
1	HEX CAP SCREW 3/8"-16 X 1.5"	*	6
2	FLAT WASHER, 3/8"	*	6
3	LOCK WASHER, 3/8"	*	10
4	HEX NUT, 3/8"-16	*	10
5	YOKE BEARING, 600CM	MIX19027	1
6	CARRIAGE BOLT 3/8"-16 X 1 1/4"	*	6
7	HANDWHEEL ASSM, 600CM	MIX5961	1
8	TILT PINION SHAFT, 600CM	MIX19061	1
9	TILT PINION-600CM	MIX19098	1
10	LEVER, BRAKE ASSM, 600CM	MIX19087	1
11	GREASE FITTING, 1/8"	*	4
12	TILT GEAR COVER-600CM	MIX29357	1
13	LOCK WASHER, 1/4"	*	2
14	HEX CAP SCREW 1/4"-20 X 3/4"	*	2
15	GEAR, INTERNAL TILT, 600CM	MIX19102	1
16	BRAKE BEARING-600CM	MIX19030	1
17	BRAKE BAND ASSY	MIX19119	1
18	GRIP	*	1
19	COTTER PIN 1/8" X 1 1/2"	*	1
20	COTTER PIN	*	1
21	KEY STOCK 3/8 SQ X 1"	*	2
22	HANDWHEEL BRG 600CM	MIX19029	1
23	FLAT WASHER, 1/2"	*	2
24	HEX NUT, 1/2" - 13	*	2

* Common hardware, can be purchased locally.

TILT / LOCK MECHANISM REPLACEMENT KITS ON NEXT PAGE...

TILT / LOCK MECHANISM REPLACEMENT KITS

600CM 600CM-PL TILT/LOCK GEAR COVER EDI# 27789 INCLUDES:

REF #	NAME	QTY
12	TILT GEAR COVER - 600CM	1
13	LOCK WASHER, 1/4"	2
14	HEX CAP SCREW, 1/4"-20 X 3/4"	2

600CM 600CM-PL TILT/LOCK LOCK MECHANISM EDI# 27790 INCLUDES:

REF #	NAME	QTY
18	GRIP	1
10	LEVER, BRAKE ASSM, 600CM	1
19	COTTER PIN 1/8" X 1 1/2"	1
20	COTTER PIN	1
11	GREASE FITTING, 1/8"	1
16	BRAKE BEARING-600CM	1
1	HEX CAP SCREW 3/8"-16 X 1 1/2"	1
2	FLAT WASHER, 3/8"	1
3	LOCK WASHER, 3/8"	1
4	HEX NUT, 3/8"-16	1
17	BRAKE BAND ASSY	1
23	FLAT WASHER-1/2"	2
24	HEX NUT, 1/2"-13	2

600CM 600CM-PL TILT/LOCK GEARS SHAFT PILLOW BLOCK EDI# 27791 INCLUDES:

REF #	NAME	QTY
15	GEAR, INTERNAL TILT, 600CM	1
9	TILT PINION - 600CM	1
1	HEX CAP SCREW 3/8"-16 X 1 1/2"	4
21	KEY STOCK, 3/8" SQ X 1"	2
8	TILT PINION SHAFT, 600CM	1
6	CARRIAGE BOLT 3/8"-16 X 1 1/4"	6
2	FLAT WASHER, 3/8"	6
3	LOCK WASHER, 3/8"	4
4	HEX NUT, 3/8"-16	6
11	GREASE FITTING, 1/8"	2
5	YOKE BEARING, 600CM	1
7	HANDWHEEL BRG 600CM	1

DRIVE SPROCKET ASSEMBLY

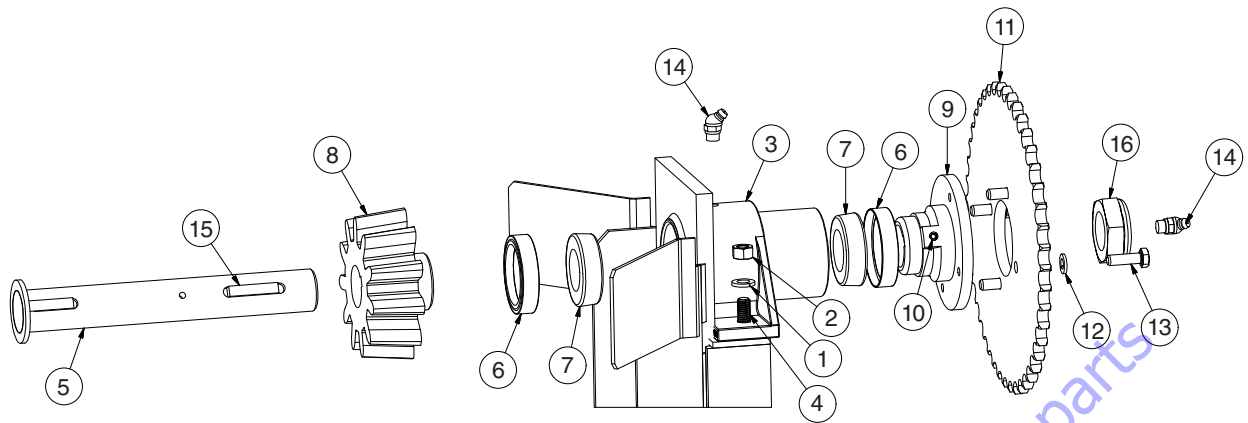

600CM/600CM-PL DRIVE SPROCKET KIT EDI# 27796 INCLUDES:

REF #	NAME	PART #	QTY
1	LOCK WASHER, 3/8"	*	2
2	HEX NUT, 3/8"-16	*	2
3	YOKE BEARING, 600CM	MIX19027	1
4	CARRIAGE BOLT, 3/8"-16 X 1 1/4"	*	2
5	SHAFT ASSM, DRIVE, 600CM	MIX19060	1
6	SEAL, GREASE DRUM RING	MIX5008	2
7	CONE BEARING-TIMKEN LM67048	MIX4298	2
8	DRIVE PINION, 600CM	MIX19103	1
9	HUB, SPROCKET, 600CM	MIX5953	1
10	SOCKET SET SCREW, 5/16"-18 X 5/16"	*	1
11	SPROCKET	MIX19158	1
12	LOCK WASHER, 5/16"	*	4
13	HEX CAP SCREW, 5/16"-18 X 1"	*	4
14	GREASE FITTING, 1/8"	*	2
15	KEY STOCK 5/16" X 1/4" X 1 1/4"	*	2
16	1 1/4"-12 JAM LOCK NUT	27792	1

* Common hardware, can be purchased locally.

STEEL DRUM, YOKE, AND DRUM SHAFT ASSEMBLY

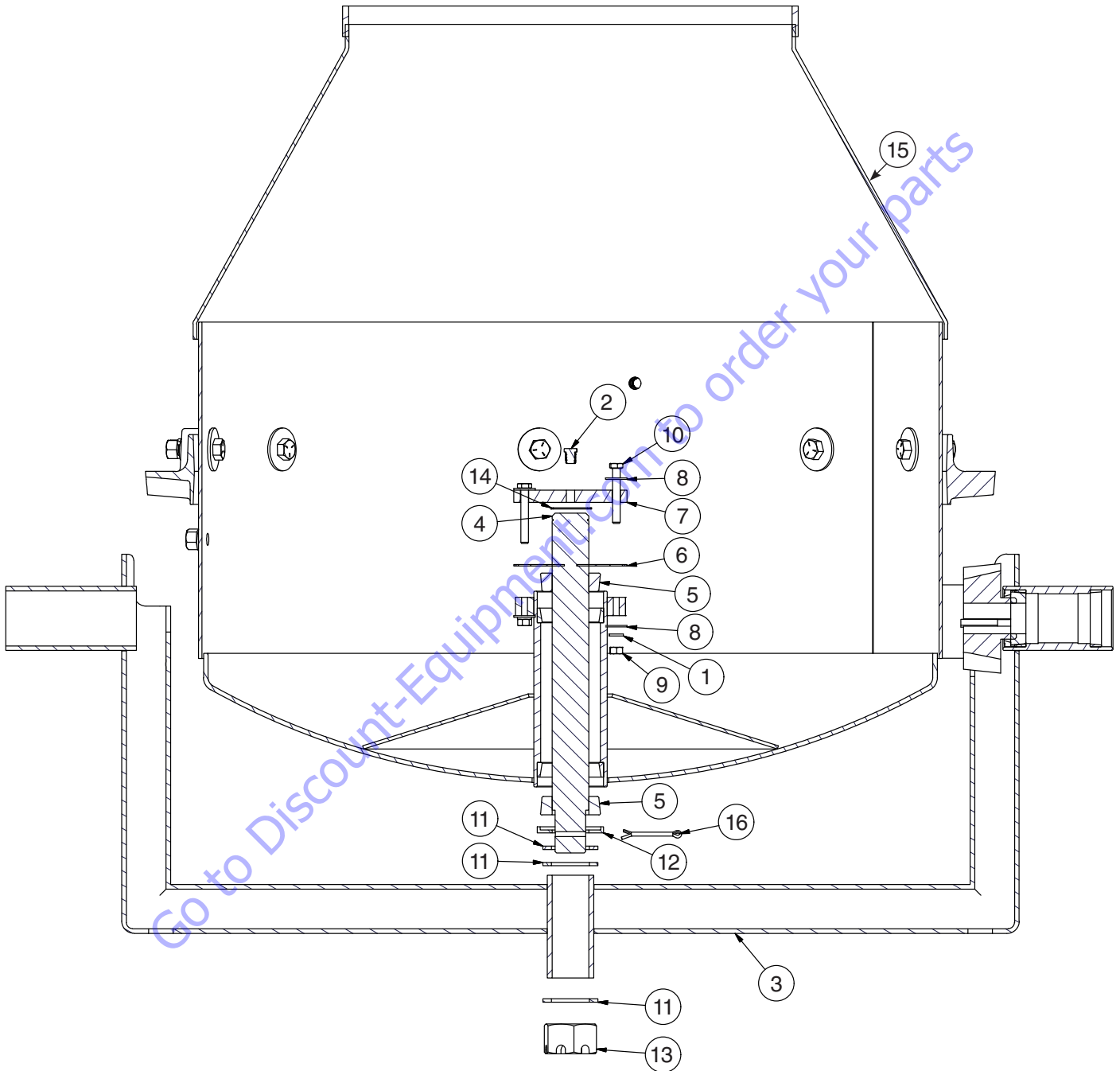

600CM/600CM-PL DRUM SHAFT KIT EDI# 27797 INCLUDES:

REF #	NAME	PART #	QTY
1	LOCK WASHER, 5/16"	*	2
2	GREASE FITTING, 1/8"	*	1
4	DRUM SHAFT ASSEMBLY	MIX19059	1
5	CONE BEARING TIMKEN #13686	MIX19507	2
6	DRUM HUB COVER GASKET	MIX772P40612	1
7	DRUM HUB COVER	MIX772-40611	1
8	FLAT WASHER, 5/16"	*	4
9	HEX NUT, 5/16"-18	*	2
10	HEX CAP SCREW 5/16"-18 X 2 1/4"	*	2
11	FLAT WASHER, 2 1/4" OD X 1 17/32" ID	*	3
12	SEAL	MIX19509	1
13	SLOTTED HEX NUT, 1 1/4" - 12	27793	1
14	SNAP RING, 1 1/2"	WR1324	1
16	COTTER PIN	*	1

* Common hardware, can be purchased locally.

YOKE ASSEMBLY EDI# 21237 INCLUDES:

REF #	NAME	QTY
3	YOKE ASSEMBLY	1

STEEL DRUM ONLY EDI# 21239 INCLUDES:

REF #	NAME	QTY
15	STEEL DRUM ASSEMBLY	1

DRUM PADDLE INSTALLATION

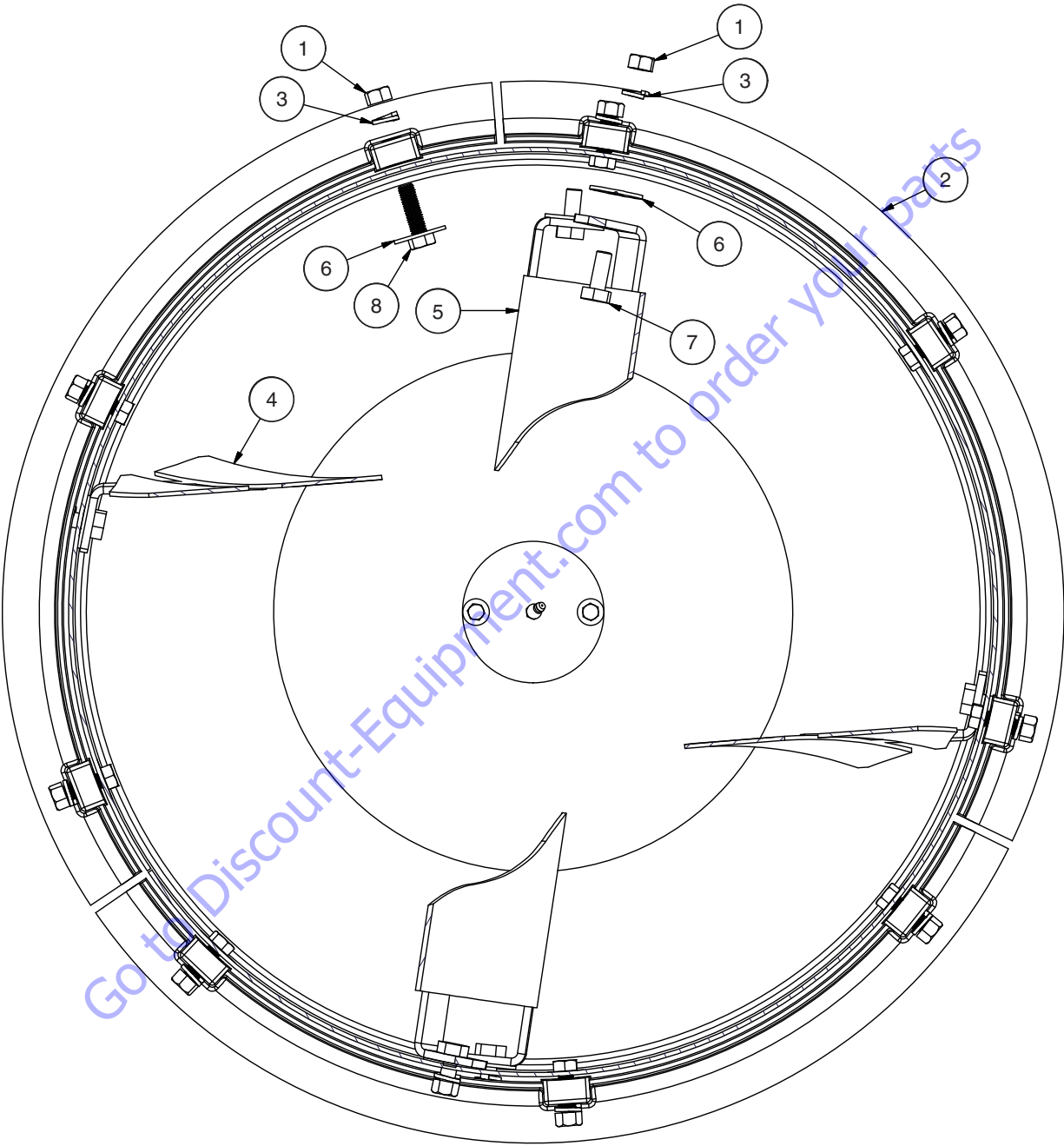

BOTTOM BLADE INSTALLATION KIT EDI# 27824 INCLUDES:

REF #	NAME	PART #	QTY
1	HEX NUT, 1/2"-13	*	2
3	LOCK WASHER, 1/2"	*	2
5	BOTTOM BLADE ASSEMBLY	MIX5733	1
6	FENDER WASHER, 1 3/4" OD X 17/32" ID	*	2
7	HEX CAP SCREW, 1/2"-13 X 1 1/4"	*	2

TOP BLADE INSTALLATION KIT EDI# 27826 INCLUDES:

REF #	NAME	PART #	QTY
1	HEX NUT, 1/2"-13	*	2
3	LOCK WASHER, 1/2"	*	2
4	TOP BLADE ASSEMBLY	MIX5734	1
6	FENDER WASHER, 1 3/4" OD X 17/32" ID	*	2
7	HEX CAP SCREW, 1/2"-13 X 1 1/4"	*	2

RING GEAR SEGMENT KIT EDI# 27794 INCLUDES:

REF #	NAME	PART #	QTY
1	HEX NUT, 1/2"-13	*	3
2	RING GEAR SEGMENT	MIX245250	1
3	LOCK WASHER, 1/2"	*	3
6	FENDER WASHER, 1 3/4" OD X 17/32" ID	*	3
8	HEX CAP SCREW, 1/2"-13 X 1 3/4"	*	3

* Common hardware, can be purchased locally.

600CM-PL DRUM

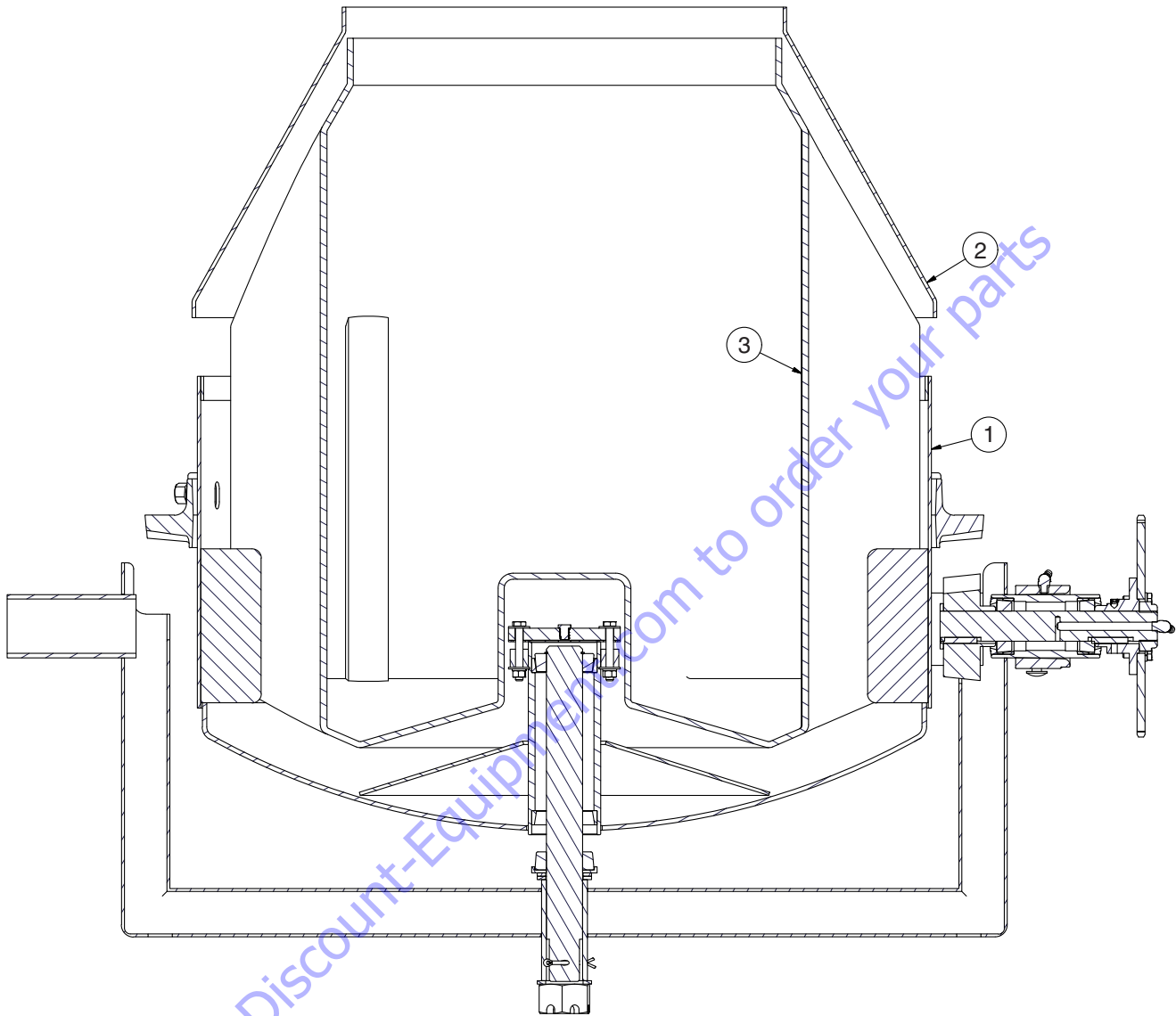

600CM-PL DRUM PARTS BREAKDOWN

REF #	NAME	PART #	QTY
1	DRUM ASSM, 600CM-PL	MIX245883	1
2	DRUM CONE ASSM, 600CM-PL	MIX245882	1
3	POLY LINER DRUM, 600CM	MIX245881	1

PINTLE INSTALLATION

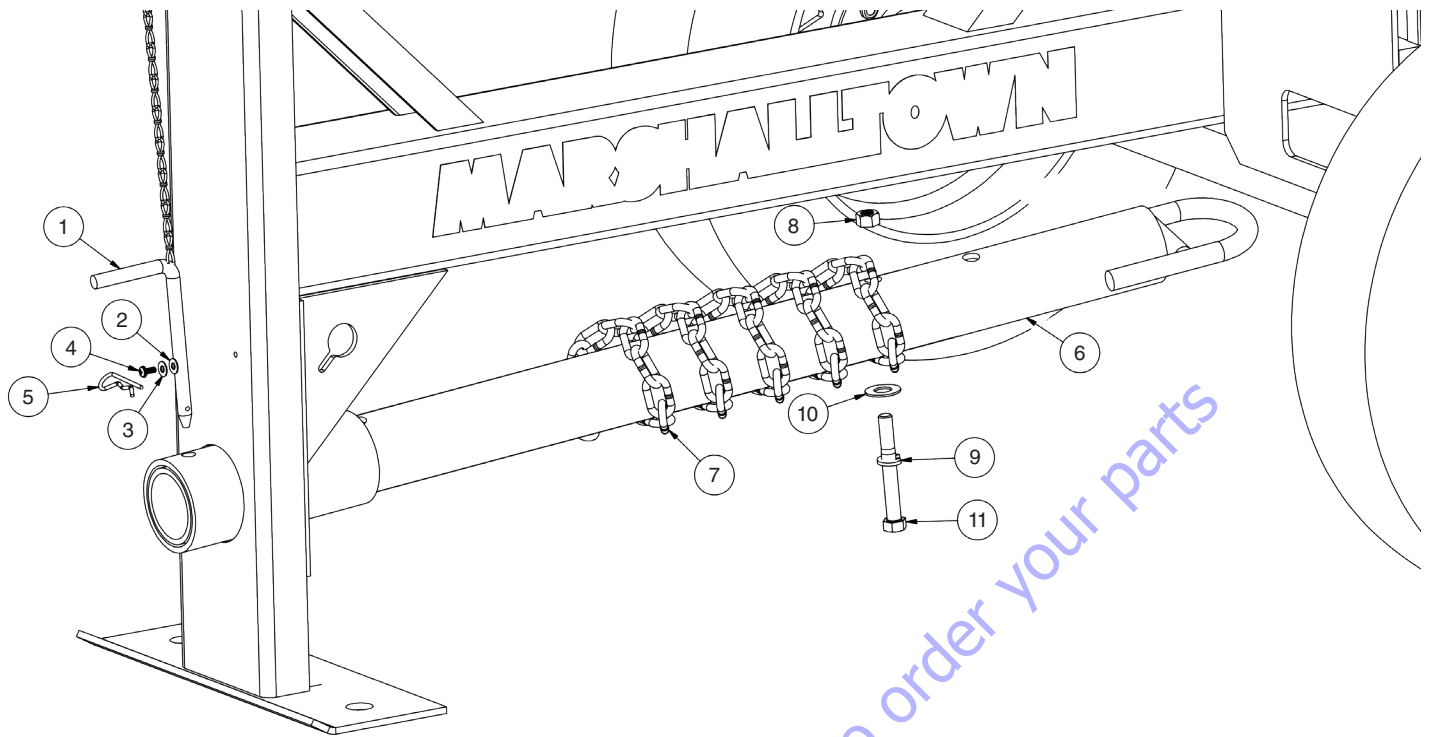

PINTLE TOW POLE KIT EDI# 27808 INCLUDES:

REF #	NAME	PART #	QTY
1	CHAIN & PIN ASSEMBLY FOR TOW POLE	MIX27821	1
2	FLAT WASHER, 1/4"	*	1
3	LOCK WASHER, 1/4"	*	1
4	HEX CAP SCREW, 1/4"-20 X 3/4"	MIX70097	1
5	SPRING CLIP FOR LOCKING PIN	MIX2776	1
6	TOW POLE FOR PINTLE HITCH	MIX232491	1
7	CHAIN, 1/4" X 58"L W/ 7/16" HOOK	MIX245480A	2
8	HEX NUT, 1/2" - 13	MIX70563	1
9	LOCK WASHER, 1/2"	MIX70655	1
10	FLAT WASHER, 1/2"	MIX70707	1
11	HEX CAP SCREW, 1/2"-13 X 4"	MIX71234	1

* Not shown in illustration

BALL HITCH INSTALLATION

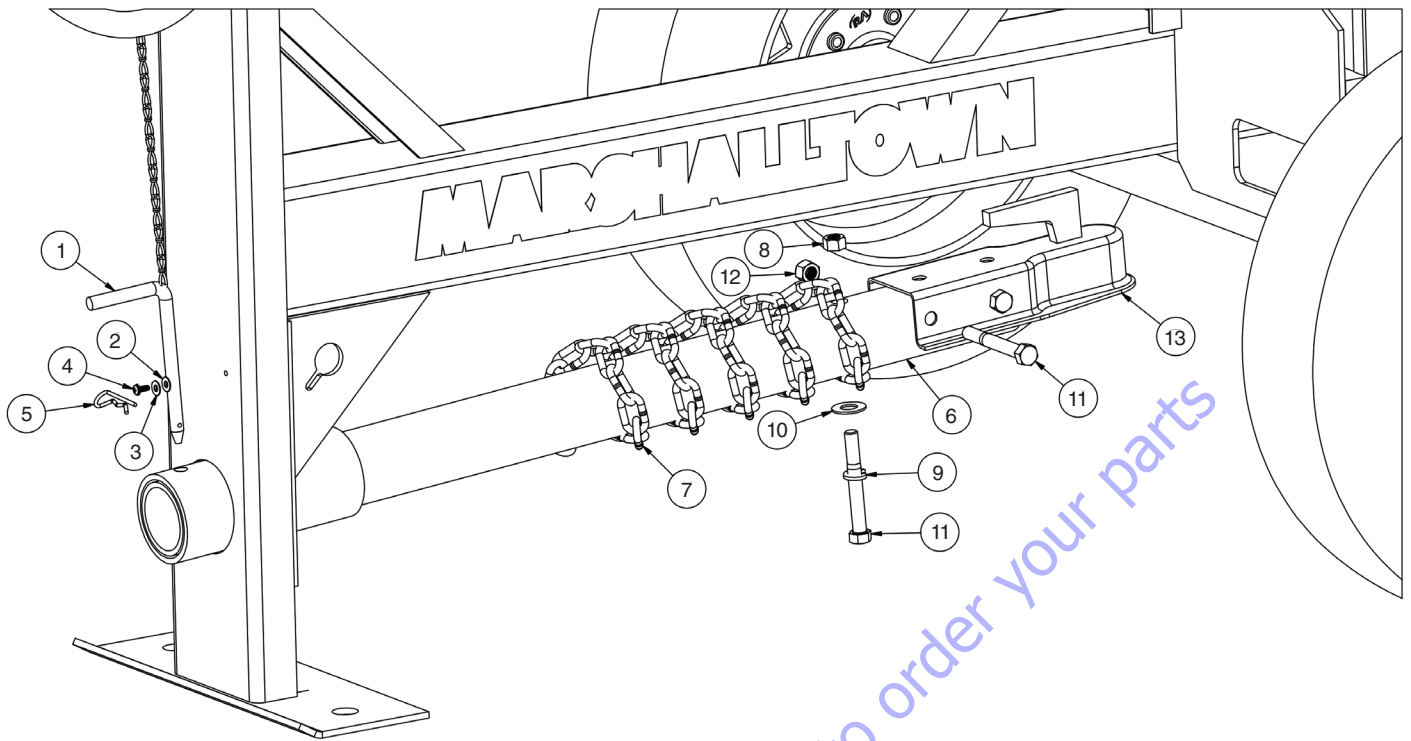

BALL TOW POLE KIT EDI# 27818 INCLUDES:

REF #	NAME	PART #	QTY
1	CHAIN & PIN ASSEMBLY FOR TOW POLE	MIX27621	1
2	FLAT WASHER, 1/4"	*	1
3	LOCK WASHER, 1/4"	*	1
4	HEX CAP SCREW, 1/4"-20 X 3/4"	MIX70097	1
5	SPRING CLIP FOR LOCKING PIN	MIX2776	1
6	TOW POLE FOR BALL HITCH	R0546	1
7	CHAIN, 1/4" X 58"L W/ 7/16" HOOK	MIX245480A	2
8	HEX NUT, 1/2" - 13	MIX70563	1
9	LOCK WASHER, 1/2"	MIX70655	1
10	FLAT WASHER, 1/2"	MIX70707	1
11	HEX CAP SCREW, 1/2"-13 X 4"	MIX71234	3
12	LOCKING NYLON NUT, 1/2"-13	WR1133	2
13	2" BALL COUPLER	WX1893	1

* Not shown in illustration

ELECTRIC MOTOR SWITCH INSTALLATION

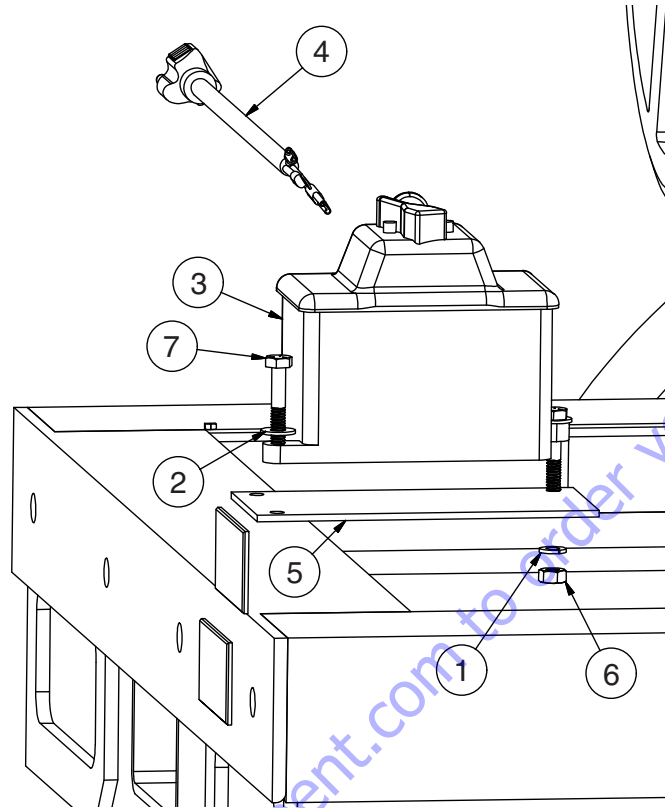

ON/OFF SWITCH ASSEMBLY EDI# 27806 INCLUDES:

REF #	NAME	PART #	QTY
1	LOCK WASHER, 1/4"	*	3
2	FLAT WASHER, 1/4"	*	3
3	ON/OFF SWITCH	27804	1
4	POWER CORD HARNESS	27803	1
5	SWITCH MOUNTING BRACKET	WX2165	1
6	HEX NUT, 1/4"-20	*	3
7	HEX CAP SCREW, 1/4"-20 X 1 1/2"	*	3

* Common hardware, can be purchased locally.

ENGINE HOUSE INSTALLATION

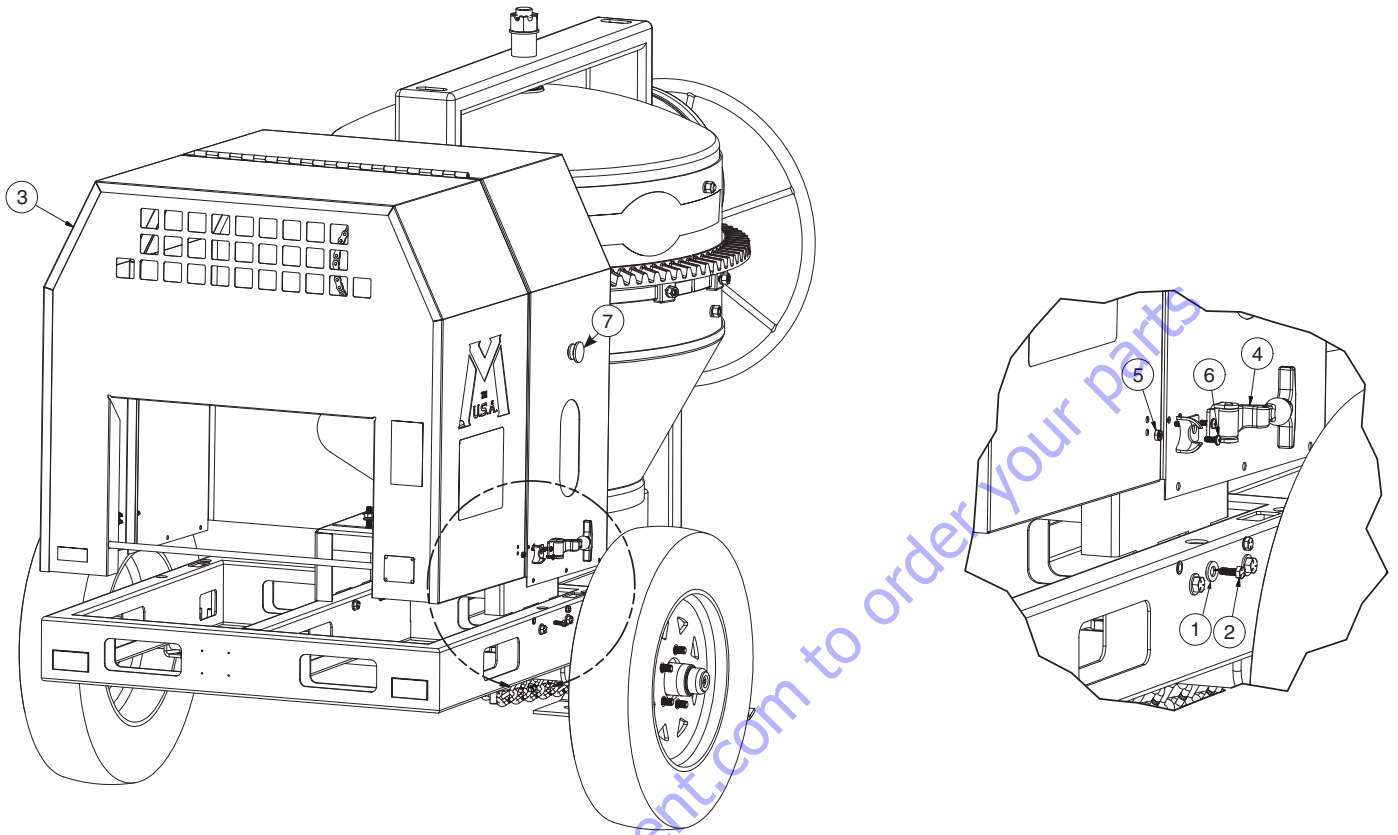

ENGINE HOUSE HARDWARE KIT EDI# 27817 INCLUDES:

REF #	NAME	QTY
1	LOCK WASHER, 1/4"	6
2	HEX CAP SCREW, 1/4"-20 X 3/4"	6
4	ENGINE HOUSE LATCH	2
5	KEPS NUT, 10-24	8
6	PHILLIPS PAN HEAD MACHINE SCREW, 10-24 X 1/2"	8

REPLACEMENT ENGINE HOUSE

REF #	NAME	PART#	QTY
3	ENGINE HOUSE (JANUARY 2019 - CURRENT) ENGINE HOUSE (PRE-JANUARY 2019)	R0506 MIX232379	1

KILL SWITCH, ALL CM GAS EDI# 23666 INCLUDES:

REF #	NAME	QTY
7	STOP BUTTON, MUSHROOM HEAD	1

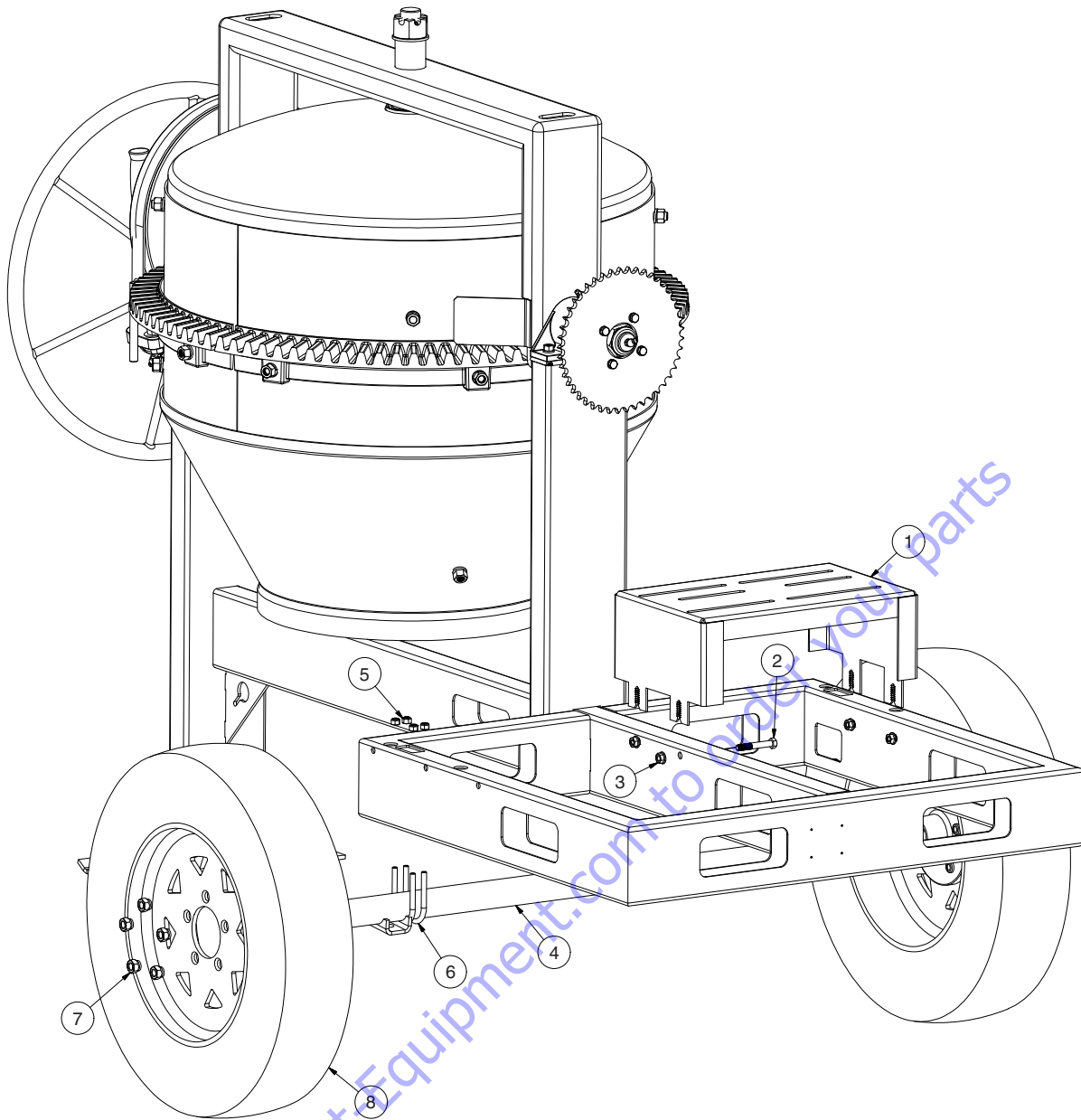

AXLE AND ENGINE TABLE PARTS BREAKDOWN JANUARY 2019-CURRENT

REF #	NAME	PART#	QTY
1	ENGINE TABLE	R0387	1
2	HEX CAP SCREW, 3/8"-16 X 2 1/2"	*	4
3	HEX NUT, 3/8"-16	*	4
4	SOLID AXLE ASSEMBLY	27309	1
5	LOCKING NYLON NUT, 5/16"-18	*	8
6	U-Bolt, 5/16"-18 X 1 1/4" Pipe Size	*	4

LUG NUT KIT EDI# 27819 INCLUDES:

REF #	NAME	QTY
7	OPEN WHEEL NUT	10

WHEEL & TIRE EDI# 27906 INCLUDES:

REF #	NAME	QTY
8	WHEEL & TIRE	1

AXLE, ENGINE TABLE AND YOKE SET SCREW PRE-JANUARY 2019

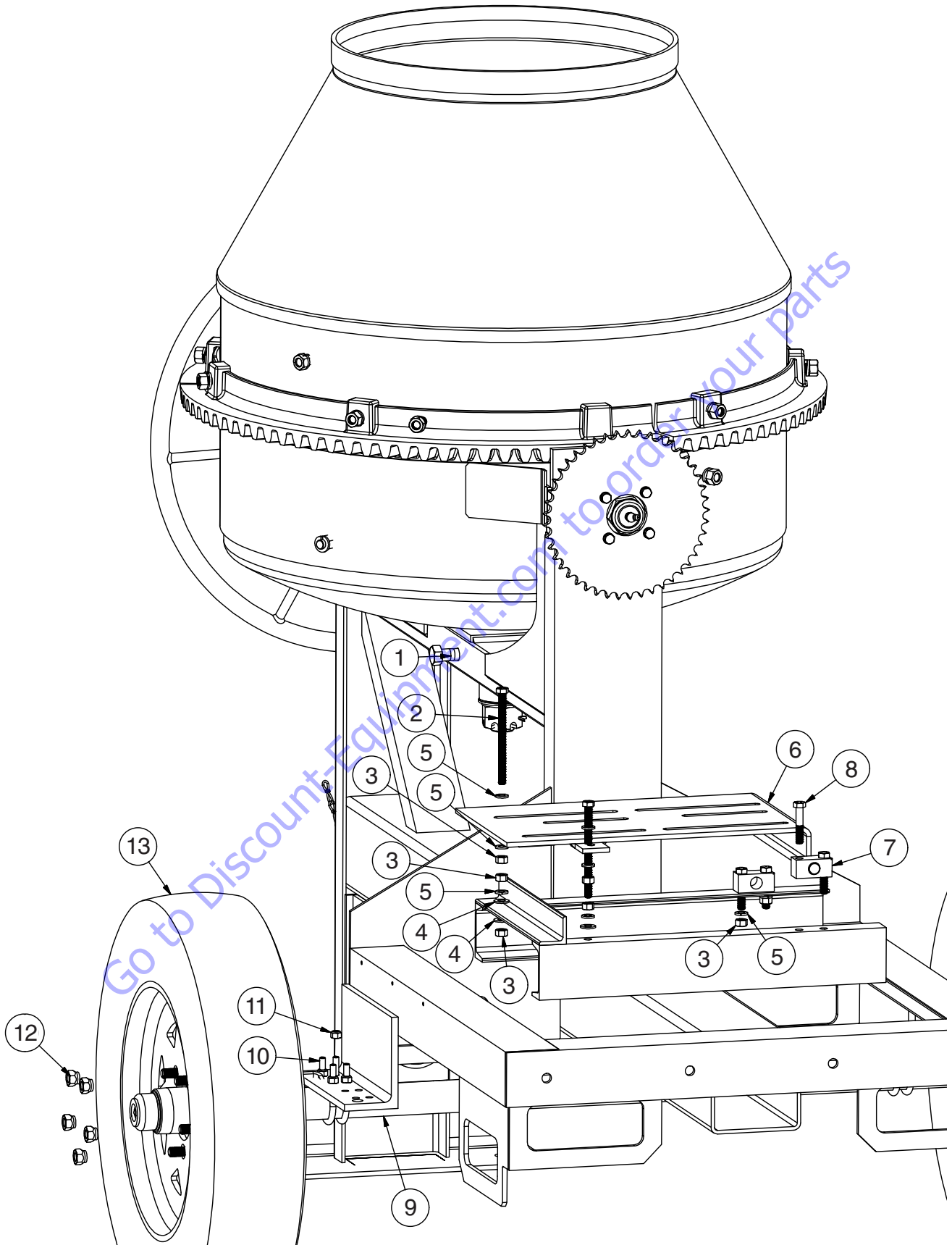

AXLE, ENGINE TABLE, AND YOKE SET SCREW PARTS BREAKDOWN PRE-JANUARY 2019

REF #	NAME	PART#	QTY
1	HEX CAP SCREW, 5/8"-11 X 2 1/2"	*	1
2	FULLY THREADED TAP BOLT, 3/8"-16 X 5"	*	2
3	HEX NUT, 3/8"-16	*	10
4	FLAT WASHER, 3/8"	*	4
5	LOCK WASHER, 3/8"	*	10
6	ENGINE TABLE	MIX245400	1
7	MOUNT, PIVOT	MIX232548	2
8	HEX CAP SCREW, 3/8"-16 X 2"	*	4
9	SOLID AXLE ASSEMBLY	27309	1
10	U-BOLT, 5/16"-18 X 1 1/4" PIPE SIZE	*	4
11	LOCKING NYLON NUT, 5/16"-18	*	8

LUG NUT KIT EDI# 27819 INCLUDES:

REF #	NAME	QTY
12	OPEN WHEEL NUT	10

WHEEL & TIRE EDI# 27906 INCLUDES:

REF #	NAME	QTY
13	WHEEL & TIRE	1

ENGINE TABLE INSTALLATION KIT EDI# 27799 INCLUDES:

REF #	NAME	QTY
2	FULLY THREADED TAP BOLT, 3/8"-16 X 5"	2
3	HEX NUT, 3/8"-16	10
4	FLAT WASHER, 3/8"	4
5	LOCK WASHER, 3/8"	10
7	MOUNT, PIVOT	2
8	HEX CAP SCREW, 3/8"-16 X 2"	4

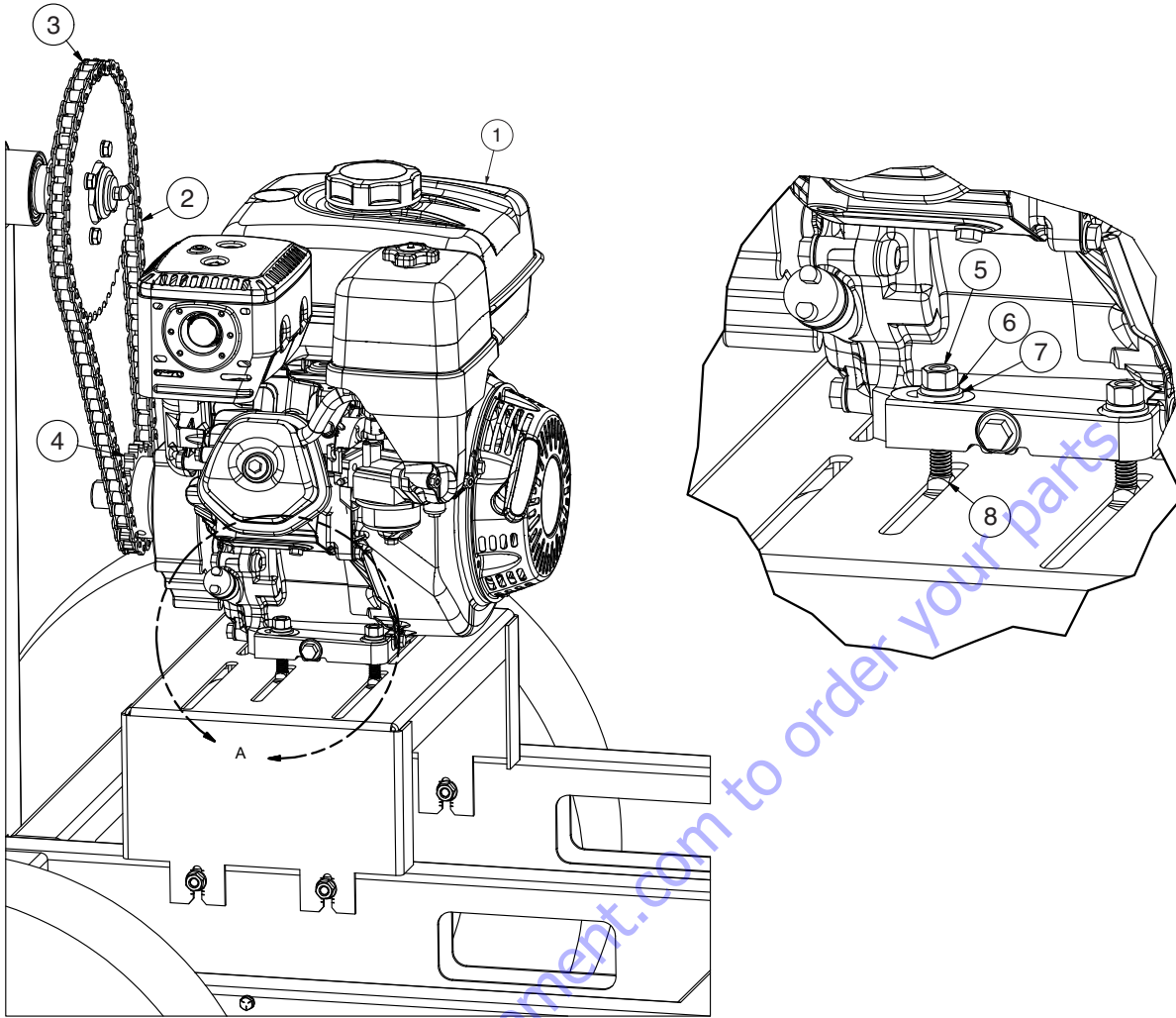

ENGINE, GX240 HONDA FOR 600CM/600CM-PL EDI# 22586 INCLUDES:

REF #	NAME	QTY
1	ENGINE, GX240 HONDA GX240K1HA W/6:1 REDUCTION	1

600CM/600CM-PL GAS CHAIN & SPROCKET EDI# 27801 INCLUDES:

REF #	NAME	PART#	QTY
2	ROLLER CHAIN, #50-1	MIX19766	1
3	CONNECTING LINK, #50	MIX19776	1
4	GAS DRIVE SPROCKET	MIX19171	1

600CM/600CM-PL GAS ENGINE INSTALL HDW EDI# 27816 INCLUDES:

REF #	NAME	QTY
5	HEX NUT, 3/8"-16	4
6	LOCK WASHER, 3/8"	4
7	FLAT WASHER, 3/8"	4
8	CARRIAGE BOLT, 3/8"-16 X 1 3/4"	4

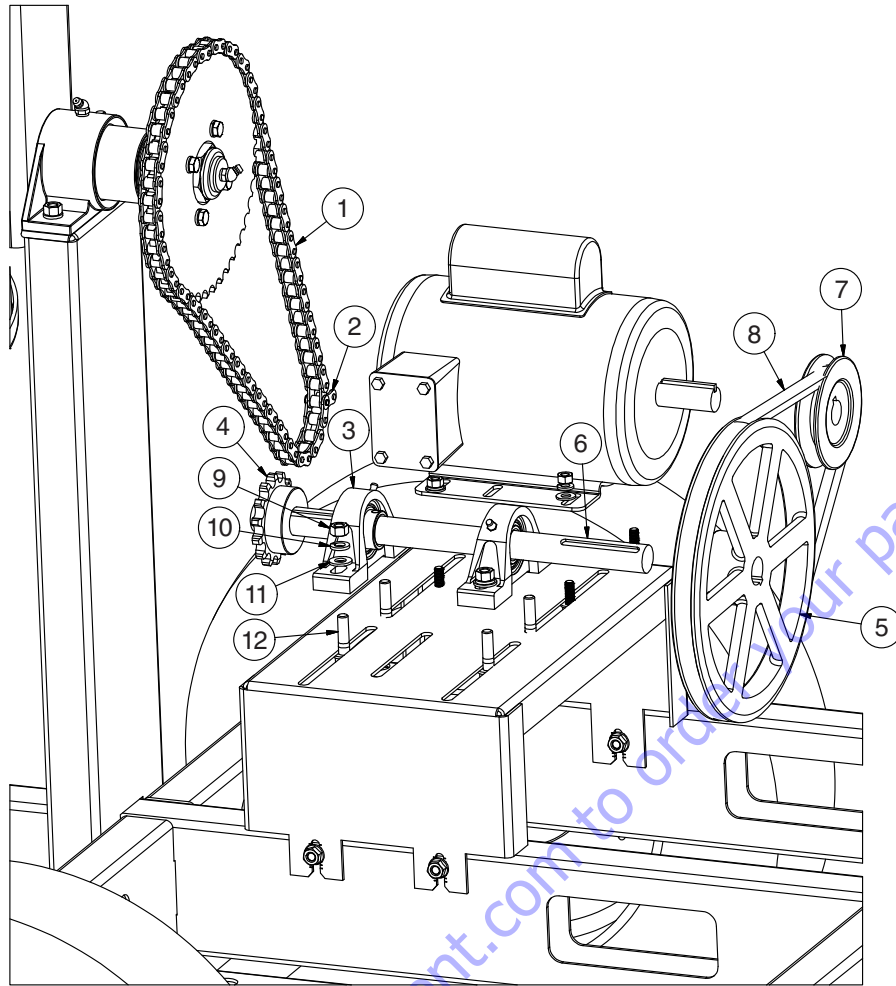

600CM/600CM-PL ELECTRIC DRIVETRAIN KIT EDI# 27802 INCLUDES:

REF #	NAME	PART#	QTY
1	ROLLER CHAIN, #50-1	MIX19766	1
2	CONNECTING LINK, #50	MIX19776	1
3	PILLOW BLOCK BEARING	MIX5082	2
4	ELECTRIC DRIVE SPROCKET	MIX5468	1
5	LARGE PULLEY	MIX5448	1
6	DRIVE SHAFT FOR ELECTRIC DRIVE	MIX757-40645	1
7	SMALL PULLEY	MIX210000	1
8	V-BELT, 5L420	MIX5398	1
9	HEX NUT, 3/8"-16	*	4
10	LOCK WASHER, 3/8"	*	8
11	FLAT WASHER, 3/8"	*	4
12	CARRIAGE BOLT, 3/8"-16 X 1 3/4"	*	4

600CM/600CM-PL ELECTRIC CHAIN & SPROCKET EDI# 27800 INCLUDES:

REF #	NAME	QTY
1	ROLLER CHAIN, #50-1	1
2	CONNECTING LINK, #50	1
4	ELECTRIC DRIVE SPROCKET	2

ELECTRIC MOTOR INSTALLATION

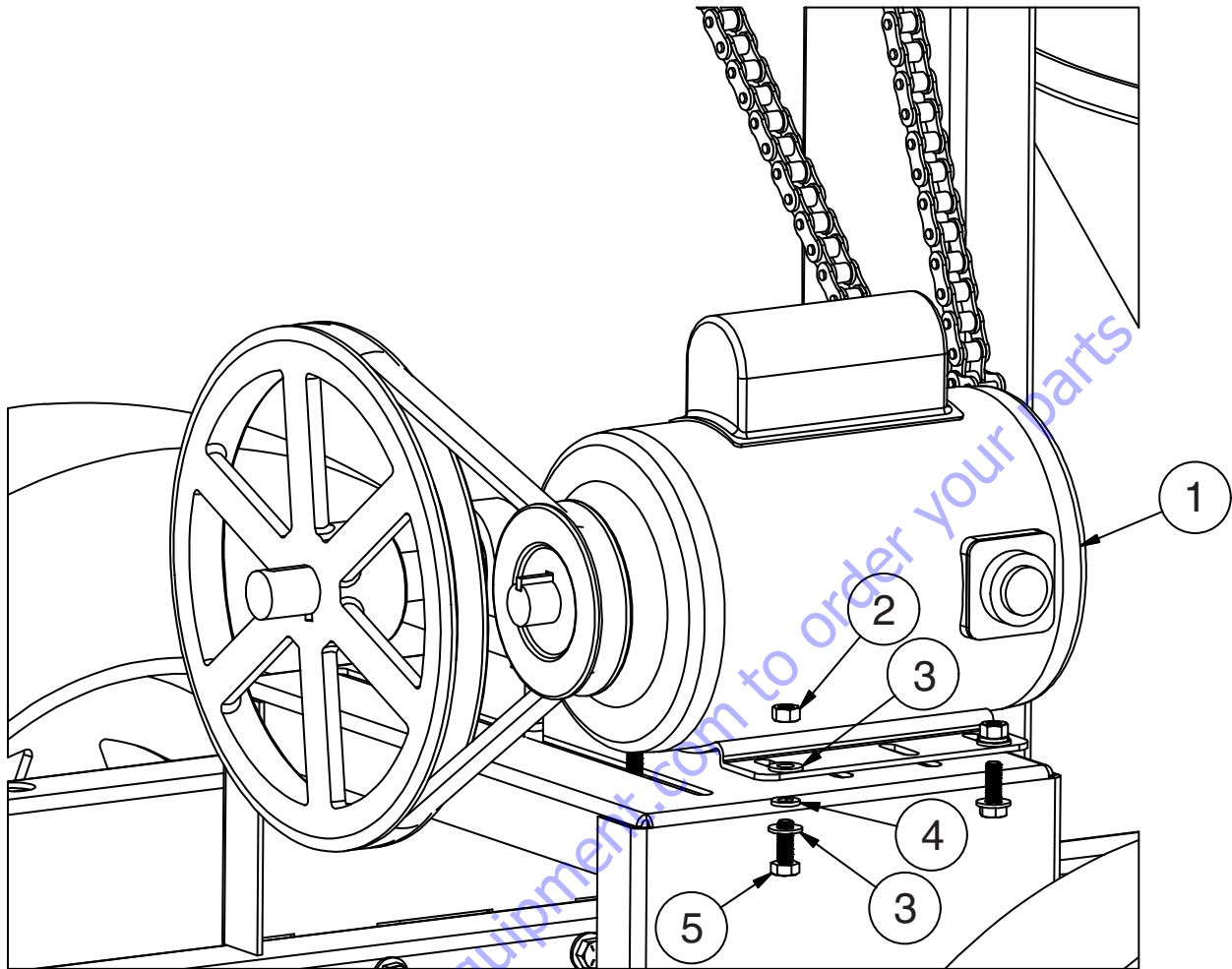

MOTOR, 1 1/2HP ELECTRIC EDI# 22448 INCLUDES:

REF #	NAME	QTY
1	1 1/2HP ELECTRIC MOTOR 1PH	1

600CM/600CM-PL ELECTRIC MOTOR INSTALL HDW EDI# 27810 INCLUDES:

REF #	NAME	QTY
2	HEX NUT, 5/16"-18	4
3	FLAT WASHER, 5/16"	8
4	LOCK WASHER, 5/16"	4
5	HEX NUT, 5/16"-18	4

PARTS FINDER

**Search Website
by Part Number**



**Search Manual
Library For Parts
Manual & Lookup Part
Numbers – Purchase
or Request Quote**

Search Manuals

Enter your manual number or description and we will search our parts manual library for you.

* Brand:

* Serial Number:

* Model:

Serial:

Part Number:

Quantity:

Submit

**Can't Find Part or
Manual? Request Help
by Manufacturer,
Model & Description**

Parts Order Form

Please fill in as much information as possible to help us find the right part for you.

Manufacturer:	<input type="text"/>
Model:	<input type="text"/>
Serial Number:	<input type="text"/>
Part Number:	<input type="text"/>
Quantity:	<input type="text"/>
Date Received:	<input type="text"/>
Order Code:	<input type="text"/>
Name:	<input type="text"/>
Company:	<input type="text"/>
Address:	<input type="text"/>
City:	<input type="text"/>
State:	<input type="text"/>
Zip:	<input type="text"/>
Phone Number:	<input type="text"/>
Fax Number:	<input type="text"/>
E-mail:	<input type="text"/>

Discount-Equipment.com is your online resource for quality parts & equipment.

Florida: **561-964-4949** Outside Florida TOLL FREE: **877-690-3101**

Need parts?

Click on this link: <http://www.discount-equipment.com/category/5443-parts/> and choose one of the options to help get the right parts and equipment you are looking for. Please have the machine model and serial number available in order to help us get you the correct parts. If you don't find the part on the website or on one of the online manuals, please fill out the request form and one of our experienced staff members will get back to you with a quote for the right part that your machine needs.

We sell worldwide for the brands: Genie, Terex, JLG, MultiQuip, Mikasa, Essick, Whiteman, Mayco, Toro Stone, Diamond Products, Generac Magnum, Airman, Haulotte, Barreto, Power Blanket, Nifty Lift, Atlas Copco, Chicago Pneumatic, Allmand, Miller Curber, Skyjack, Lull, Skytrak, Tsurumi, Husquvarna Target, , Stow, Wacker, Sakai, Mi-T- M, Sullair, Basic, Dynapac, MBW, Weber, Bartell, Bennar Newman, Haulotte, Ditch Runner, Menegotti, Morrison, Contec, Buddy, Crown, Edco, Wyco, Bomag, Laymor, Barreto, EZ Trench, Bil-Jax, F.S. Curtis, Gehl Pavers, Heli, Honda, ICS/PowerGrit, IHI, Partner, Imer, Clipper, MMD, Koshin, Rice, CH&E, General Equipment, ,AMida, Coleman, NAC, Gradall, Square Shooter, Kent, Stanley, Tamco, Toku, Hatz, Kohler, Robin, Wisconsin, Northrock, Oztec, Toker TK, Rol-Air, Small Line, Wanco, Yanmar



Go to Discount-Equipment.com to order your parts



www.Discount-Equipment.com