

REVISED STARTING SERIAL # 060710016



MODEL C-10

PARTS LIST MANUAL



CRACK CHASER

(RANDOM CRACK SAW)



PARTS FINDER

**Search Website
by Part Number**



**Search Manual
Library For Parts
Manual & Lookup Part
Numbers – Purchase
or Request Quote**

Search Manuals

Enter your information to help us find the right parts manual for your equipment.

* Brand:

* Model:

* Serial:

* Part Number:

SEARCH

**Can't Find Part or
Manual? Request Help
by Manufacturer,
Model & Description**

Parts Order Form

Please fill in the following information to help us find the right part for your equipment.

Manufacturer:	<input type="text"/>
Model:	<input type="text"/>
Description:	<input type="text"/>
Part Number:	<input type="text"/>
Quantity:	<input type="text"/>
Notes:	<input type="text"/>

Submit

Discount-Equipment.com is your online resource for quality parts & equipment.

Florida: **561-964-4949** Outside Florida TOLL FREE: **877-690-3101**

Need parts?

Click on this link: <http://www.discount-equipment.com/category/5443-parts/> and choose one of the options to help get the right parts and equipment you are looking for. Please have the machine model and serial number available in order to help us get you the correct parts. If you don't find the part on the website or on one of the online manuals, please fill out the request form and one of our experienced staff members will get back to you with a quote for the right part that your machine needs.

We sell worldwide for the brands: Genie, Terex, JLG, MultiQuip, Mikasa, Essick, Whiteman, Mayco, Toro Stone, Diamond Products, Generac Magnum, Airman, Haulotte, Barreto, Power Blanket, Nifty Lift, Atlas Copco, Chicago Pneumatic, Allmand, Miller Curber, Skyjack, Lull, Skytrak, Tsurumi, Husquvarna Target, Stow, Wacker, Sakai, Mi-T-M, Sullair, Basic, Dynapac, MBW, Weber, Bartell, Bennar Newman, Haulotte, Ditch Runner, Menegotti, Morrison, Contec, Buddy, Crown, Edco, Wyco, Bomag, Laymor, EZ Trench, Bil-Jax, F.S. Curtis, Gehl Pavers, Heli, Honda, ICS/PowerGrit, IHI, Partner, Imer, Clipper, MMD, Koshin, Rice, CH&E, General Equipment, Amida, Coleman, NAC, Gradall, Square Shooter, Kent, Stanley, Tamco, Toku, Hatz, Kohler, Robin, Wisconsin, Northrock, Oztec, Toker TK, Rol-Air, APT, Wylie, Ingersoll Rand / Doosan, Innovatech, Con X, Ammann, Mecalac, Makinex, Smith Surface Prep, Small Line, Wanco, Yanmar

READ AND UNDERSTAND THE OPERATORS INSTRUCTION MANUAL THOROUGHLY BEFORE ATTEMPTING TO OPERATE THIS EQUIPMENT. Death or serious injury could occur if this machine is used improperly.



SAFETY MESSAGES



The safety instructions are preceded by a graphic alert message of DANGER, WARNING, or CAUTION.



Indicates an imminent hazard which, if not avoided, will result in death or serious injury.



Indicates an imminent hazard which, if not avoided, can result in death or serious injury.



Indicates hazards which, if not avoided, could result in serious injury and or damage to the equipment.

GASOLINE Powered Equipment



- Do not operate gasoline powered equipment without adequate ventilation. Carbon monoxide is an invisible, odorless gas that can kill.

ELECTRICAL Powered Equipment



- ELECTRICAL HAZARD** - Be sure equipment is properly grounded. Failure to comply could kill or result in serious injury.



The engine exhaust from this product contains chemicals known to the State of California to cause cancer, birth defects or other reproductive harm.

GENERAL INSTRUCTIONS



- You must read and understand the operators instruction manual and all other manuals associated with this machine. For your safety and the safety of others around you, it is extremely important to fully understand how to operate this machine in the way it was intended. Different model machines or older/newer versions of the same model may have different parts and controls that you need to understand. If instructions are not readable or available DO NOT USE this machine and contact Discount-equipment for a replacement Manual.
- You must be able to physically handle the bulk weight and power of this machine. If not properly controlled this machine can cause death or serious injury.
- Do not operate this machine in an impaired mental state. You must be able to exercise good judgement and reactions to maintain a safe working environment.
- This is a "one person" machine which means only one operator can be operating the machine at any one time. For the safety of others, maintain a safe operating distance to other personnel. Your work area should be defined and appropriately marked so bystanders and coworkers do not stand or walk near this machine and end up seriously injured by flying debris or exposing them to harmful noise or dust.
- This equipment is for Commercial use. Although this is a "one person" machine your work team should understand how to shut this machine off and quickly get medical help if an accident strikes the operator.
- Keep all guards in place during operation. The guards are to provide protection from inadvertent contact with dangerous moving parts, pinch points, or hot surfaces.
- Wear appropriate Personal Protective Equipment (PPE) including safety glasses, safety boots, work gloves, respiratory protection, hearing protection, and head protection. Do not wear loose clothing that can get tangled in moving parts. Failure to do so could result

in dismemberment or death. **Wear an approved respirator when removing hazardous materials or when grinding/cutting dry materials. Some dust particles such as concrete dust can contain silicate particles which can cause silicosis (a very serious lung disease). Contact NIOSH or OSHA for further details. When wet grinding/cutting, avoid contact with the concrete/asphalt slurry which can cause serious skin irritations.**

- You must maintain this machine per the maintenance schedule in the operator manual. Remember before adjusting, servicing, or fueling this machine, disconnect the source of power to the machine by disconnecting the spark plug (Gas models), or by unplugging the electrical power cord (electric models) or air hose (Pneumatic models) AT THE MACHINE so you can assure yourself it remains unplugged while you are working on it. Do not modify this machine. Use only genuine EDCO parts and accessories. Repairs and service should be performed by approved EDCO dealers or authorized technicians.
- You should look carefully around the area before you begin work so you can identify potential hazards such as deck inserts, pipes, columns, openings, electrical cords or outlets, or any other objects protruding from the slab surface.
- This machine has no brain so you must use your own. There is no substitute for safety. The safety decals on the machine are to serve as a reminder for information you must already know before you begin using this machine. Take a moment to reread the safety decals each time you use the machine. If your machine is missing any decals, contact Discount-equipment for a replacement.

PARTS LIST MANUAL

MODEL C-10

<u>Section</u>	<u>Page Number</u>
Safety Messages / General Instructions	2
How To Order Replacement Parts	3
Illustration 1 : Main Grouping	4,5
Illustration 2 : Arbor Assembly	6
Illustration 3 : Engine & Belt Drive Grouping	7
Illustration 4 : Motor & Belt Drive Grouping	8,9
Illustration 5 : Motor Mounting Detail	10
Illustration 6 : Optional Wheel Kit	11
Limited Equipment Warranty	Back Page

C-10 CRACK CHASERS		
PART NO.	MODEL	POWER OPTIONS
49100	C10-9H	HONDA 9HP GX270
49500	C10-11H	HONDA 11HP GX340
49600	C10-13H	HONDA 13HP GX390
49700	C10-5B/230/1	BALDOR 5HP-1PHASE-230V
49400-230	C10-5B/230/3	BALDOR 5HP-3PHASE-230V
49400-460	C10-5B/460/3	BALDOR 5HP-3PHASE-460V



ILLUSTRATION 1 : MAIN GROUPING

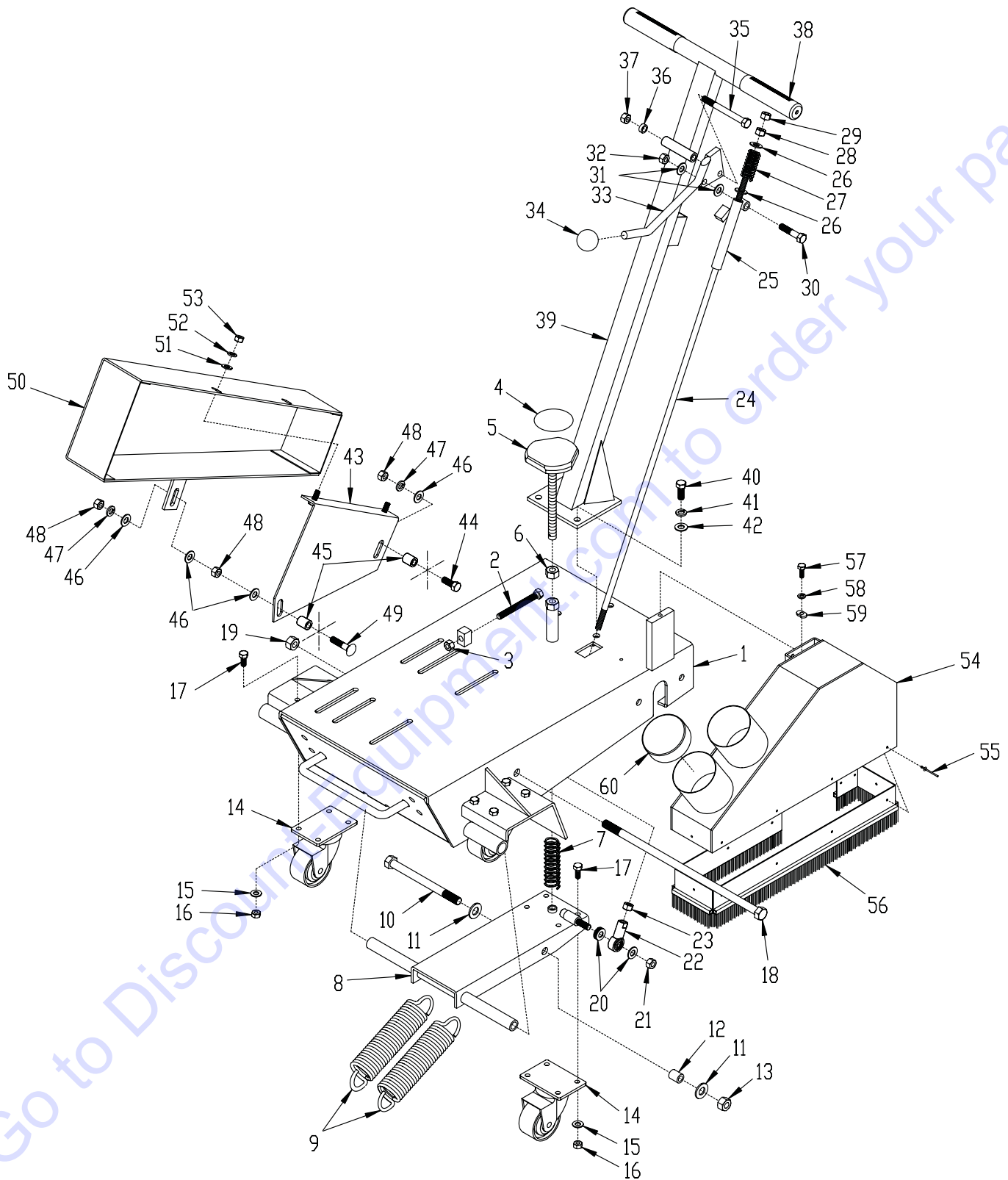

PARTS LISTING - ILLUSTRATION 1 : MAIN GROUPING

ITEM#	PART#	DESCRIPTION	QTY.	ITEM#	PART#	DESCRIPTION	QTY.
1	49001	MAIN FRAME	1	33	49007	LEVER, DISENGAGE	1
2	52015	BOLT, TAP 3/8-16 X 3-1/2(FULL THD.)	1	34	14023	KNOB, BALL 1-3/8 W/ 1/2-13THD, BLK.	1
3	10404	NUT 3/8-16	1	35	49023	SCREW, CAP 3/8-16 X 3-3/4	1
4	80007	DECAL, CUT CONTROL - DN/UP (SMALL)	1	36	10113	SPACER, STEEL 9/16OD X 3/8ID X 7/32	2
5	49014	KNOB, CONTROL W/ 1/2-13 X 6-3/4"ROD	1	37	10156	NUT, HEX NYLON LOCK 3/8-16	1
6	10417	NUT 1/2-13	1	38	79022	GRIP, HAND 1" MODEL RG	2
7	10922	SPRING, COMP. 1"OD X 3.75"FL	1	39	49008	HANDLE BAR	1
8	49002	FORK	1	40	10055	SCREW, CAP 3/8-16 X 1	3
9	41041	SPRING, EXT. 1.75"OD X 8"L	2	41	10811	WASHER, LOCK 3/8	3
10	10329	SCREW, CAP 1/2-20 X 6	1	42	10025	WASHER, FLAT 3/8 SAE	3
11	10312	WASHER, FLAT 1/2 SAE	2	43	49009	BRACKET, BELT COVER	1
12	40312	SPACER, STEEL 1/2"ID X 1-1/8"L	1	44	10055	SCREW, CAP 3/8-16 X 1	1
13	10205	NUT, LOCK 1/2-20	1	*27029	SCREW, CAP 3/8-16 X 1-3/4	1	
14	49003	CASTER, SWIVEL 2-1/2 X 1-1/4	3	*45	52045	SPACER, STEEL 5/8OD X 3/8ID X 3/4L	2
15	10213	WASHER, FLAT 5/16 SAE	12	46	10025	WASHER, FLAT 3/8 SAE	4
16	10807	NUT, LOCK 5/16-18	12	47	10811	WASHER, LOCK 3/8	2
17	10053	SCREW, CAP 5/16-18 X 3/4	12	48	10404	NUT 3/8-16	3
18	52014	SCREW, HEX HD CAP 1/2-13 X 14	1	49	10087	BOLT, CARRIAGE 3/8-16 X 1-3/4 F.T.	1
19	10407	NUT, LOCK 1/2-13	1	*10908	BOLT, CARRIAGE 3/8-16 X 2-1/2	1	
20	10025	WASHER, FLAT 3/8 SAE	5	50	49010	COVER, BELT	1
21	10004	NUT, LOCK 3/8-24	1	51	10213	WASHER, FLAT 5/16 SAE	2
22	10919	ROD END, FEMALE 3/8-24 R.H. THREAD	1	52	10801	WASHER, LOCK 5/16	2
23	10014	NUT 3/8-24	1	53	10054	NUT 5/16-18	2
24	49004	LINKAGE, DISENGAGE 3/8 X 31-1/2"L	1	54	49011	GUARD, BLADE	1
25	49005	LINKAGE SUPPORT, UPPER	1	55	10128	RIVET, BLIND 1/8 X .250L X .262HD	10
26	10025	WASHER, FLAT 3/8 SAE	2	56	49012	BRUSH 1" X 32-1/2"L	1
27	51035	SPRING, COMP. .828"OD X 2"FL	1	57	10018	SCREW, CAP 1/4-20 X 3/4	1
28	10014	NUT 3/8-24	1	58	10038	WASHER, LOCK 1/4	1
29	10004	NUT, LOCK 3/8-24	1	59	49013	TAB, BLADE GUARD STOP	1
30	10029	SCREW, CAP 3/8-24 X 1-3/4	1	60	64030	PLUG, CAP 3" TUBE	2
31	10025	WASHER, FLAT 3/8 SAE	2	*USED ON SINGLE PHASE UNITS ONLY			
32	10004	NUT, LOCK 3/8-24	1				



ILLUSTRATION 2 : ARBOR ASSEMBLY

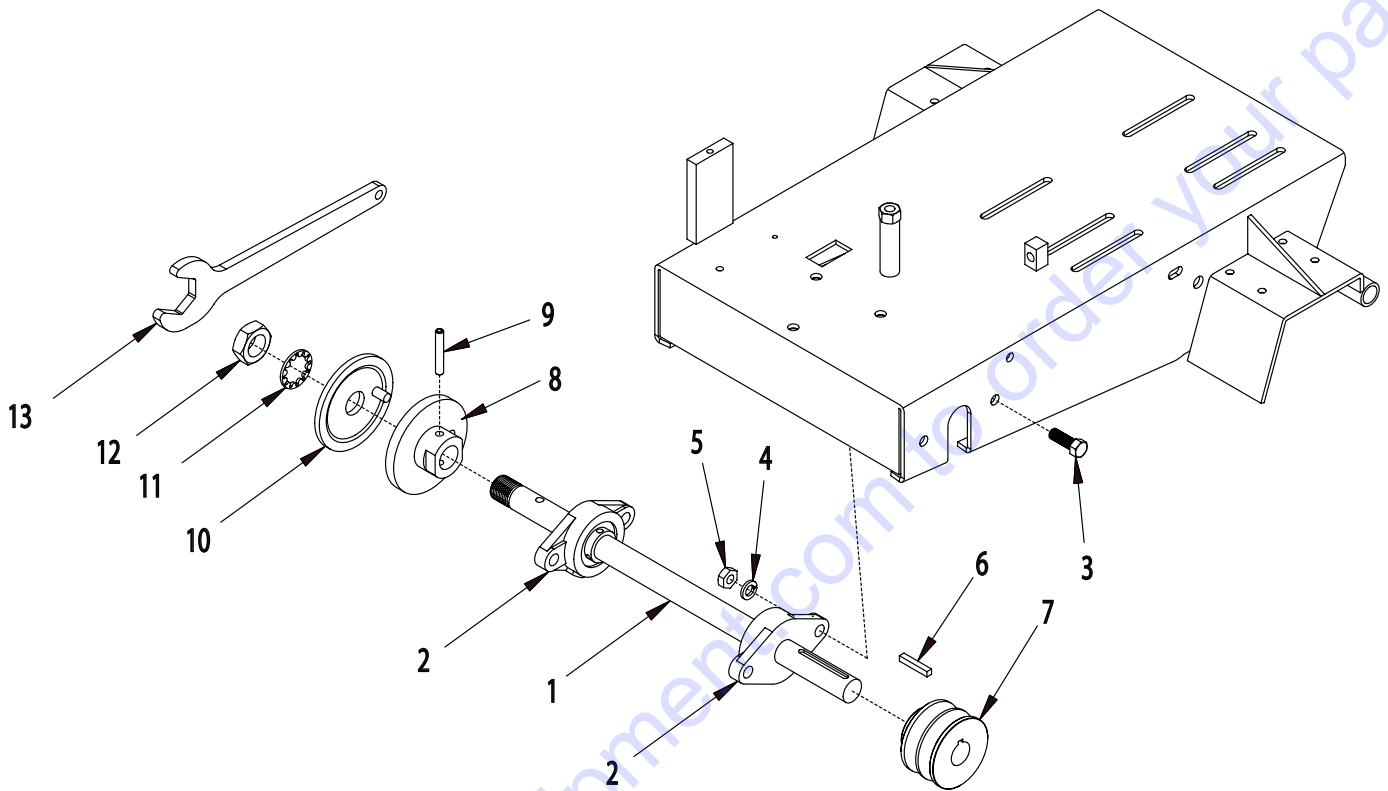

ITEM#	PART#	DESCRIPTION	QTY.
1	69050	ARBOR SHAFT 19-1/4"L	1
2	62022	BEARING, BALL 1" 2-HOLE FLANGE	2
3	10003	SCREW, CAP 7/16-20 X 1-1/4	4
4	10450	WASHER, LOCK 7/16	4
5	10481	NUT 7/16-20	4
6	10301	KEY 1/4 SQ X 1-1/2	1
7	79024	SHEAVE 3"OD X 2GR.B X 1"BORE	1
8	56026	ARBOR BACKING PLATE 4"	1
9	10211	PIN, ROLL 5/16 X 2	1
10	56025	ARBOR BLADE CAP 4"OD W/1"HOLE	1
11	55009	WASHER, LOCK, INT. TOOTH 1"	1
12	50019	NUT, JAM 1-14	1
13	50445	WRENCH, ARBOR 1-1/2	2

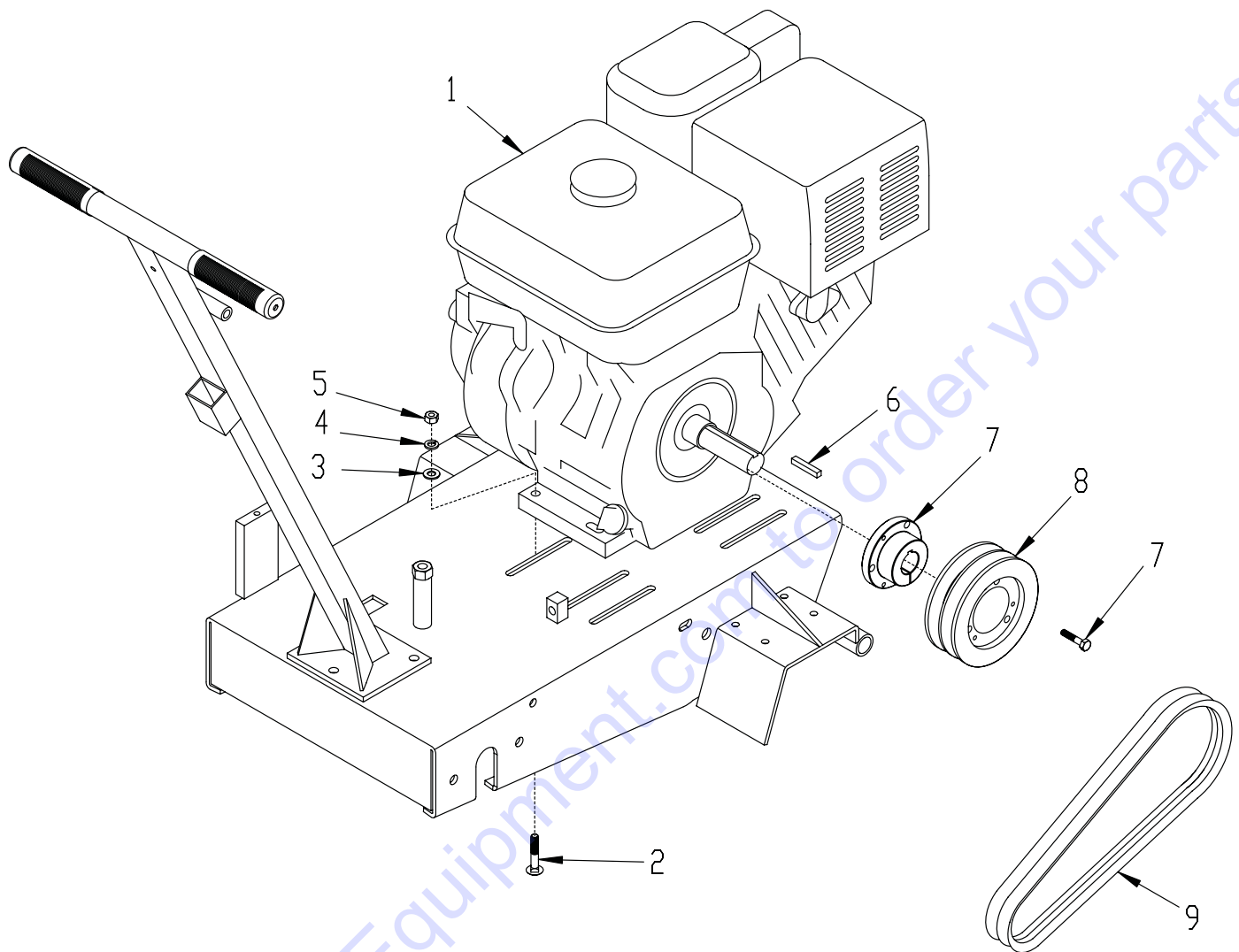
ILLUSTRATION 3 : ENGINE & BELT DRIVE GROUPING

ITEM#	PART#	DESCRIPTION	QTY.
1		ENGINE, HONDA	1
	15027	9 HP GX270-QXC9	
	79045	11 HP GX340K1-QXC9	
	15029	13 HP GX390K1-QXC9	
2	10918	BOLT, CARRIAGE 5/16-18 X 1-3/4 F.T.	4
3	10213	WASHER, FLAT 5/16 SAE	4
4	10801	WASHER, LOCK 5/16	4
5	10054	NUT 5/16-18	4
6	10301	KEY 1/4 SQ X 1-1/2	1
7	10043	BUSHING, SHEAVE SDS X 1"BORE	1
8	79032	SHEAVE 5"OD X 2GR.B X SDS	1
9	85028	BELT 5L-440	2

ILLUSTRATION 4 : MOTOR & BELT DRIVE GROUPING

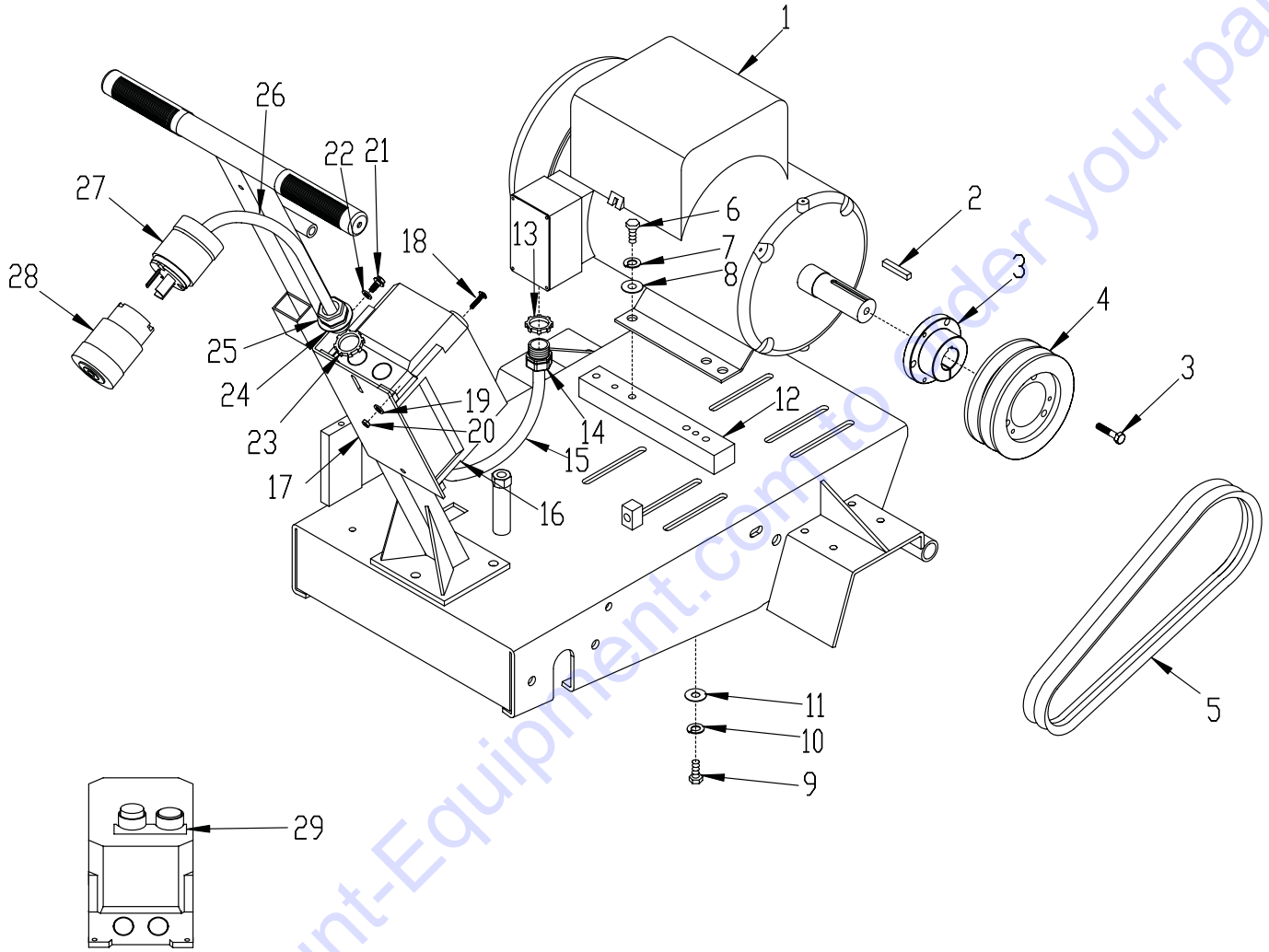

VIEW ORIENTATION:

LOOKING DOWN FROM
OPERATOR'S POSITION

NOTE:
REFER TO ILLUSTRATION 5
FOR MOTOR MOUNTING DETAIL

PARTS LISTING - ILLUSTRATION 4 : MOTOR & BELT DRIVE GROUPING			
ITEM#	PART#	DESCRIPTION	QTY.
1		MOTOR, BALDOR	1
	81026	5HP-1PH 60HZ-230V 3450RPM (SHOWN IN ILLUSTRATION)	
	81022	5HP-3PH-60HZ-230/460V 3450RPM	
2	10301	KEY 1/4 SQ X 1-1/2	1
3	10558	BUSHING, SHEAVE SDS X 1-1/8"BORE	1
4	79032	SHEAVE 5"OD X 2GR.B X SDS	1
5	85028	BELT 5L-440	2
6	10055	SCREW, CAP 3/8-16 X 1	4
7	10811	WASHER, LOCK 3/8	4
8	10025	WASHER, FLAT 3/8 SAE	4
9	10806	SCREW, CAP 5/16-18 X 1	4
10	10801	WASHER, LOCK 5/16	4
11	10213	WASHER, FLAT 5/16 SAE	4
12	49021	MOUNT BAR, MOTOR	2
13	10740	CONDUIT LOCK NUT 3/4 NP	1
14	10959	STRAIN RELIEF 3/4 NPT X .550-.650"	1
15	49025	WIRE HARNESS 10/3 X 34" (1 PHASE UNITS)	1
	49027	WIRE HARNESS 12/4 X 34" (3 PHASE UNITS)	1
16		STARTER	1
	16405	11-M1-BRF-P23-23-23060 (230V, 3 PHASE UNITS)	
	16406	11-M1-BRF-P14-10-46060 (460V, 3 PHASE UNITS)	
	16410	11-M1-BRF-P30-26-23060 (230V, 1 PHASE UNITS)	
17	86027	MOUNTING BRKT., LOVATO STARTER	1
18	10362	SCREW, MACHINE 8-32 X 3/4	4
19	10038	WASHER, LOCK 1/4	4
20	10462	NUT 8-32	4
21	10846	SCREW, CAP STSHW 1/4-20 X 1/2	2
22	10038	WASHER, LOCK 1/4	2
23	10740	CONDUIT LOCK NUT 3/4 NP	2
24	77081	WASHER, FLAT 1-9/16 X 1-1/16 X .06	2
25	10959	STRAIN RELIEF 3/4 NPT X .550-.650"	2
26	49024	WIRE HARNESS 10/3 X 22" (1 PHASE UNITS)	1
	49026	WIRE HARNESS 12/4 X 22" (3 PHASE UNITS)	1
*27	40037	PLUG, LOCKING 20A/250V	1
*28	40000	PLUG CONNECTOR, LOCKING 20A/250V	1
29	91177	DECAL, STOP-RESET & START (STARTER)	1
	*NOTE:	PLUG AND CONNECTOR (ITEMS 27 & 28) ARE NOT INCLUDED WITH THREE PHASE UNITS.	

ILLUSTRATION 5 : MOTOR MOUNTING DETAIL

"A" for 3 Phase Motor
"B" for 1 Phase Motor

BALDOR CAT. NO. M3613T
5 H.P. 3 PHASE 60 Hz
230/460 VOLT 12/6 F.L.AMPS
3450 RPM

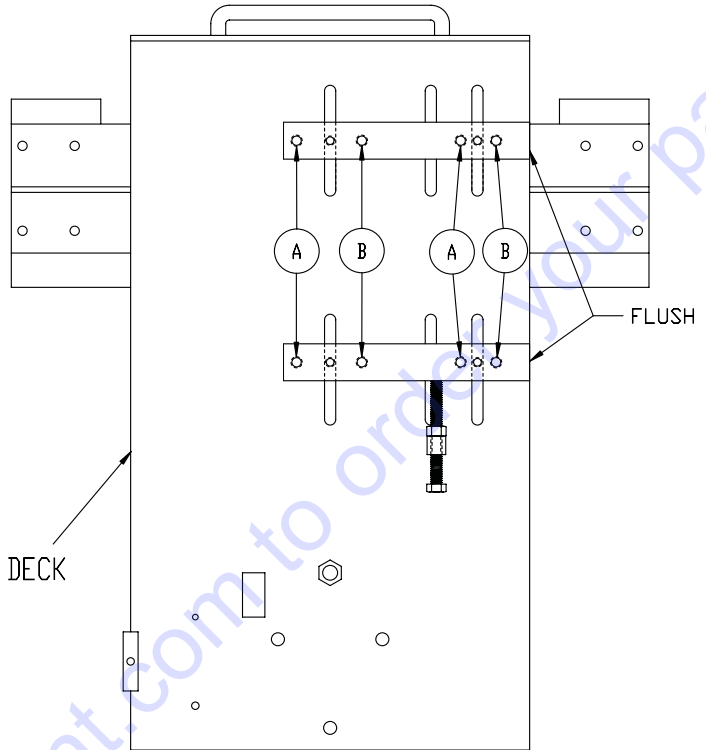
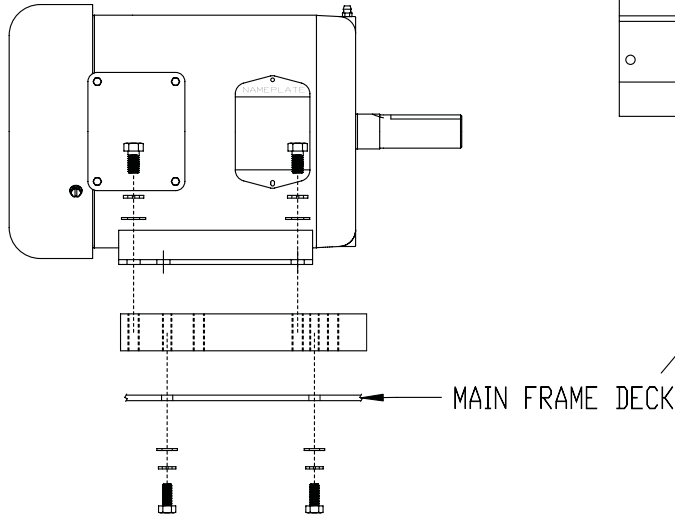

BALDOR CAT. NO. L3608T
5 H.P. 1 PHASE 60 Hz
230 VOLT 19.5 F.L.AMPS
3450 RPM

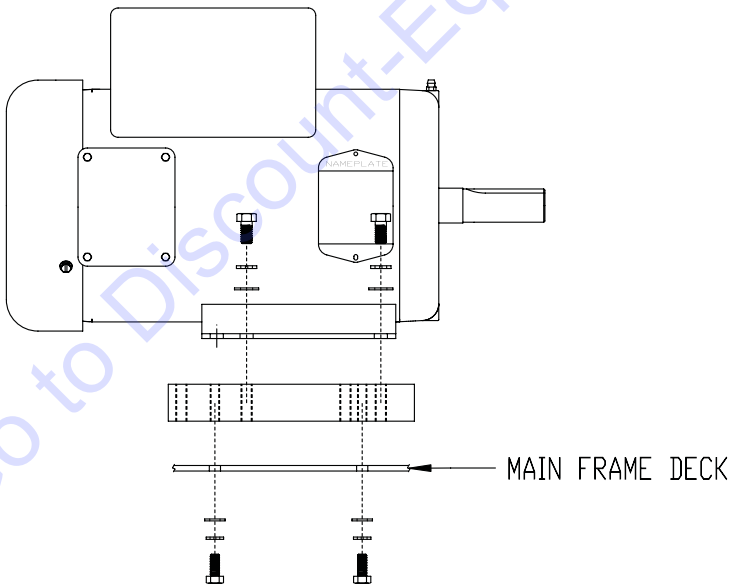
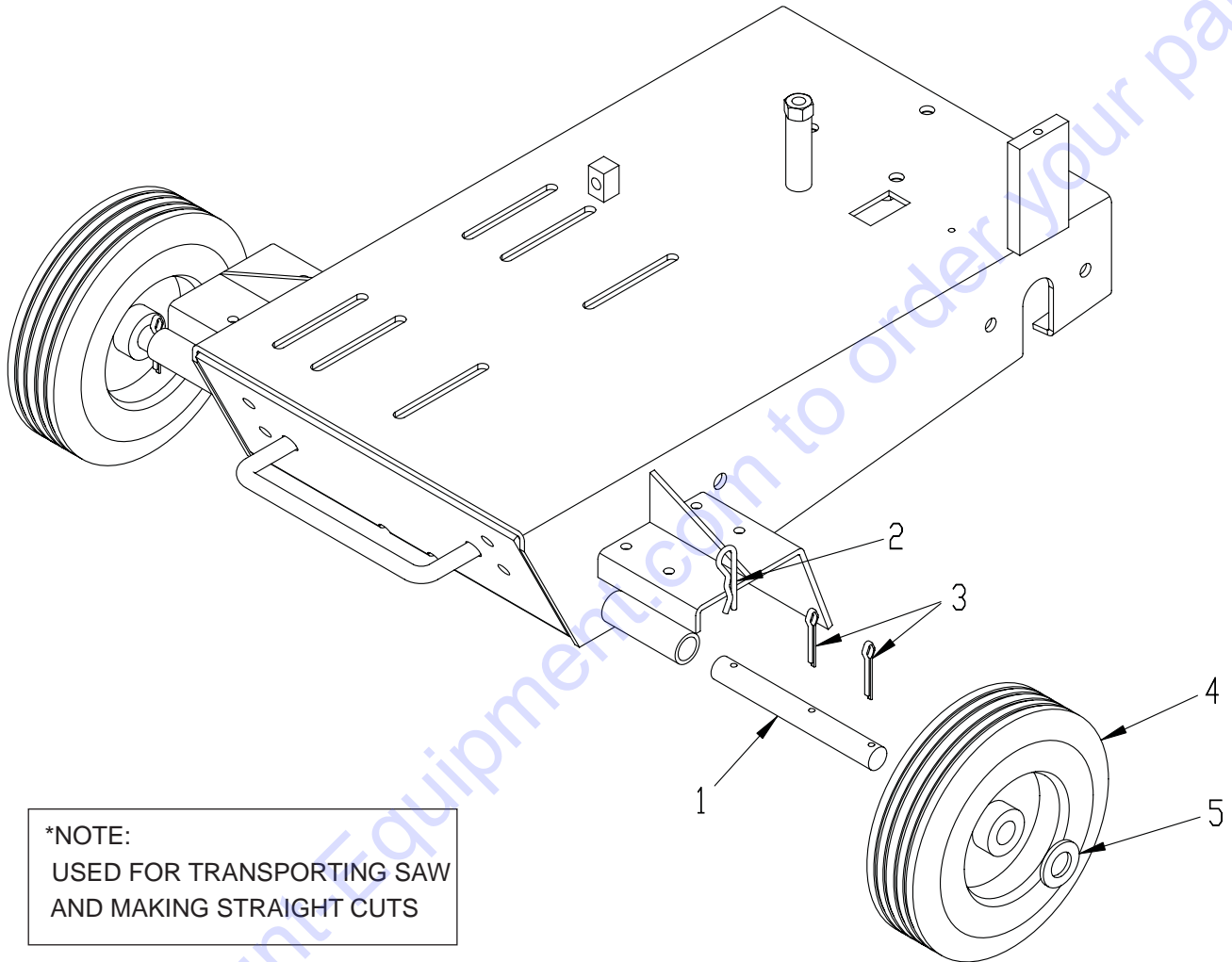

ILLUSTRATION 6 : OPTIONAL WHEEL KIT



*NOTE:
USED FOR TRANSPORTING SAW
AND MAKING STRAIGHT CUTS

ITEM#	PART#	DESCRIPTION	QTY.
-	49015	WHEEL KIT (INCLUDES ITEMS 1 THRU 5)	-
1	49017	AXLE SHAFT 3/4" DIA. X 6-1/2" L	2
2	10124	PIN, HAIR COTTER 1"	2
3	10306	PIN, COTTER 3/16 X 1-1/4	4
4	80028	WHEEL 6 X 2 X 3/4" BRG.	2
5	10009	WASHER, FLAT 3/4 SAE	2

PARTS FINDER

**Search Website
by Part Number**



**Search Manual
Library For Parts
Manual & Lookup Part
Numbers – Purchase
or Request Quote**

Search Manuals

Enter your information to help us find the right parts manual for your machine.

* Brand:

* Model:

* Serial:

* Part Number:

SEARCH

**Can't Find Part or
Manual? Request Help
by Manufacturer,
Model & Description**

Parts Order Form

Please fill in the following information to help us find the right part for your machine.

Manufacturer:	<input type="text"/>
Model:	<input type="text"/>
Description:	<input type="text"/>
Part Number:	<input type="text"/>
Quantity:	<input type="text"/>
Notes:	<input type="text"/>

Discount-Equipment.com is your online resource for quality parts & equipment.

Florida: **561-964-4949** Outside Florida TOLL FREE: **877-690-3101**

Need parts?

Click on this link: <http://www.discount-equipment.com/category/5443-parts/> and choose one of the options to help get the right parts and equipment you are looking for. Please have the machine model and serial number available in order to help us get you the correct parts. If you don't find the part on the website or on one of the online manuals, please fill out the request form and one of our experienced staff members will get back to you with a quote for the right part that your machine needs.

We sell worldwide for the brands: Genie, Terex, JLG, MultiQuip, Mikasa, Essick, Whiteman, Mayco, Toro Stone, Diamond Products, Generac Magnum, Airman, Haulotte, Barreto, Power Blanket, Nifty Lift, Atlas Copco, Chicago Pneumatic, Allmand, Miller Curber, Skyjack, Lull, Skytrak, Tsurumi, Husquvarna Target, Stow, Wacker, Sakai, Mi-T-M, Sullair, Basic, Dynapac, MBW, Weber, Bartell, Bennar Newman, Haulotte, Ditch Runner, Menegotti, Morrison, Contec, Buddy, Crown, Edco, Wyco, Bomag, Laymor, EZ Trench, Bil-Jax, F.S. Curtis, Gehl Pavers, Heli, Honda, ICS/PowerGrit, IHI, Partner, Imer, Clipper, MMD, Koshin, Rice, CH&E, General Equipment, Amida, Coleman, NAC, Gradall, Square Shooter, Kent, Stanley, Tamco, Toku, Hatz, Kohler, Robin, Wisconsin, Northrock, Oztec, Toker TK, Rol-Air, APT, Wylie, Ingersoll Rand / Doosan, Innovatech, Con X, Ammann, Mecalac, Makinex, Smith Surface Prep, Small Line, Wanco, Yanmar