

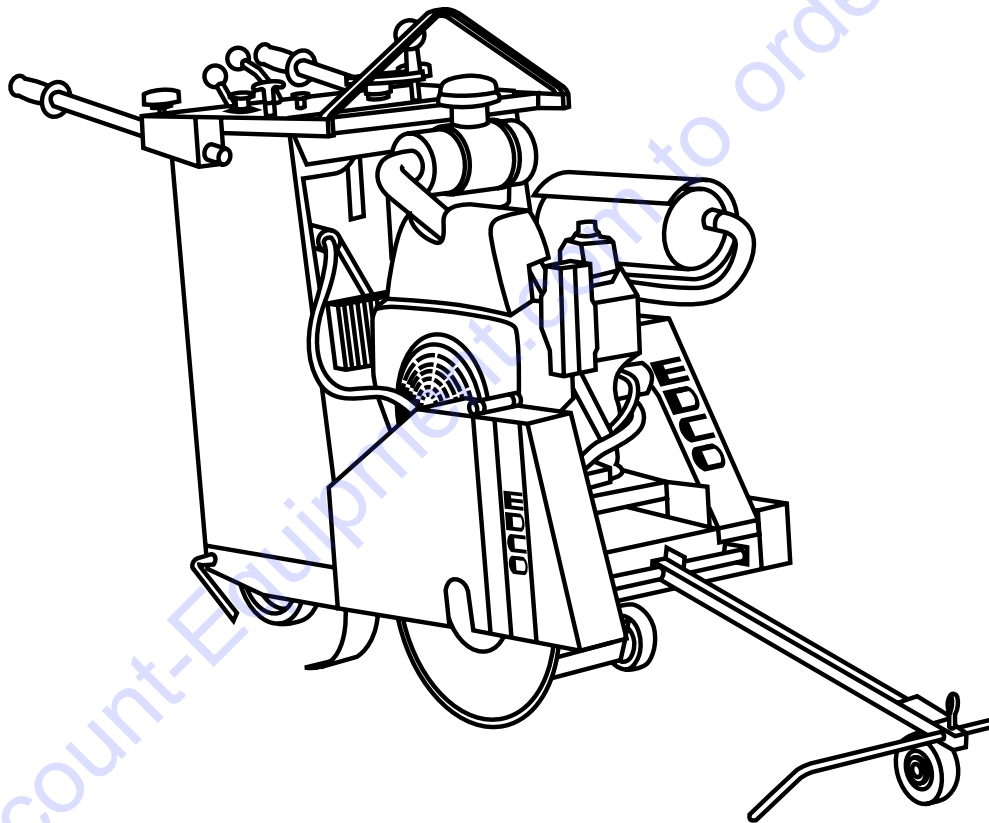

STARTING SERIAL # 1,001

## PARTS LIST MANUAL

# Model SS-20



**CONCRETE / ASPHALT SAW**



# PARTS FINDER

**Search Website  
by Part Number**



**Search Manual  
Library For Parts  
Manual & Lookup Part  
Numbers – Purchase  
or Request Quote**

**Search Manuals**

Enter your information to help us find the right parts manual for your machine.

\* Brand:

\* Model:

\* Serial:

\* Part Number:

SEARCH

**Can't Find Part or  
Manual? Request Help  
by Manufacturer,  
Model & Description**

**Parts Order Form**

Please fill in the following information to help us find the right part for your machine.

Manufacturer:	<input type="text"/>
Model:	<input type="text"/>
Description:	<input type="text"/>
Part Number:	<input type="text"/>
Quantity:	<input type="text"/>
Notes:	<input type="text"/>

Submit

Discount-Equipment.com is your online resource for quality parts & equipment.

Florida: **561-964-4949** Outside Florida TOLL FREE: **877-690-3101**

**Need parts?**

Click on this link: <http://www.discount-equipment.com/category/5443-parts/> and choose one of the options to help get the right parts and equipment you are looking for. Please have the machine model and serial number available in order to help us get you the correct parts. If you don't find the part on the website or on one of the online manuals, please fill out the request form and one of our experienced staff members will get back to you with a quote for the right part that your machine needs.

We sell worldwide for the brands: Genie, Terex, JLG, MultiQuip, Mikasa, Essick, Whiteman, Mayco, Toro Stone, Diamond Products, Generac Magnum, Airman, Haulotte, Barreto, Power Blanket, Nifty Lift, Atlas Copco, Chicago Pneumatic, Allmand, Miller Curber, Skyjack, Lull, Skytrak, Tsurumi, Husquvarna Target, Stow, Wacker, Sakai, Mi-T-M, Sullair, Basic, Dynapac, MBW, Weber, Bartell, Bennar Newman, Haulotte, Ditch Runner, Menegotti, Morrison, Contec, Buddy, Crown, Edco, Wyco, Bomag, Laymor, EZ Trench, Bil-Jax, F.S. Curtis, Gehl Pavers, Heli, Honda, ICS/PowerGrit, IHI, Partner, Imer, Clipper, MMD, Koshin, Rice, CH&E, General Equipment, Amida, Coleman, NAC, Gradall, Square Shooter, Kent, Stanley, Tamco, Toku, Hatz, Kohler, Robin, Wisconsin, Northrock, Oztec, Toker TK, Rol-Air, APT, Wylie, Ingersoll Rand / Doosan, Innovatech, Con X, Ammann, Mecalac, Makinex, Smith Surface Prep, Small Line, Wanco, Yanmar

READ AND UNDERSTAND THE OPERATORS INSTRUCTION MANUAL THOROUGHLY BEFORE ATTEMPTING TO OPERATE THIS EQUIPMENT. Death or serious injury could occur if this machine is used improperly.



## SAFETY MESSAGES



The safety instructions are preceded by a graphic alert message of DANGER, WARNING, or CAUTION.



Indicates an imminent hazard which, if not avoided, will result in death or serious injury.



Indicates an imminent hazard which, if not avoided, will result in death or serious injury.



Indicates hazards which, if not avoided, could result in serious injury and or damage to the equipment.

## GASOLINE

Powered Equipment



- Do not operate gasoline powered equipment without adequate ventilation. Carbon monoxide is an invisible, odorless gas that can kill.

## ELECTRICAL

Powered Equipment



- ELECTRICAL HAZARD** - Be sure equipment is properly grounded. Failure to comply could kill or result in serious injury.



The engine exhaust from this product contains chemicals known to the State of California to cause cancer, birth defects or other reproductive harm.

## GENERAL INSTRUCTIONS



- You must read and understand the operators instruction manual and all other manuals associated with this machine. For your safety and the safety of others around you, it is extremely important to fully understand how to operate this machine in the way it was intended. Different model machines or older/newer versions of the same model may have different parts and controls that you need to understand. If instructions are not readable or available DO NOT USE this machine and contact Discount-equipment for a replacement Manual.
- You must be able to physically handle the bulk weight and power of this machine. If not properly controlled this machine can cause death or serious injury.
- Do not operate this machine in an impaired mental state. You must be able to exercise good judgement and reactions to maintain a safe working environment.
- This is a "one person" machine which means only one operator can be operating the machine at any one time. For the safety of others, maintain a safe operating distance to other personnel. Your work area should be defined and appropriately marked so bystanders and coworkers do not stand or walk near this machine and end up seriously injured by flying debris or exposing them to harmful noise or dust.
- This equipment is for Commercial use. Although this is a "one person" machine your work team should understand how to shut this machine off and quickly get medical help if an accident strikes the operator.
- Keep all guards in place during operation. The guards are to provide protection from inadvertent contact with dangerous moving parts, pinch points, or hot surfaces.
- Wear appropriate Personal Protective Equipment (PPE) including safety glasses, safety boots, work gloves, respiratory protection, hearing protection, and head protection. Do not wear loose clothing that can get tangled in moving parts. Failure to do so could result in dismemberment or death. **Wear an approved respirator when removing hazardous materials or when grinding/cutting dry materials. Some dust particles such as concrete dust can contain silicate particles which can cause silicosis (a very serious lung disease). Contact NIOSH or OSHA for further details. When wet grinding/cutting, avoid contact with the concrete/asphalt slurry which can cause serious skin irritations.**
- You must maintain this machine per the maintenance schedule in the operator manual. Remember before adjusting, servicing, or fueling this machine, disconnect the source of power to the machine by disconnecting the spark plug (Gas models), or by unplugging the electrical power cord (electric models) or air hose (Pneumatic models) AT THE MACHINE so you can assure yourself it remains unplugged while you are working on it. Do not modify this machine. Use only genuine EDCO parts and accessories. Repairs and service should be performed by approved EDCO dealers or authorized technicians.
- You should look carefully around the area before you begin work so you can identify potential hazards such as deck inserts, pipes, columns, openings, electrical cords or outlets, or any other objects protruding from the slab surface.
- This machine has no brain so you must use your own. There is no substitute for safety. The safety decals on the machine are to serve as a reminder for information you must already know before you begin using this machine. Take a moment to reread the safety decals each time you use the machine. If your machine is missing any decals, contact Discount-equipment for a replacement.

# PARTS LIST MANUAL

## MODEL SS - 20

Section	Page Number
General Safety Precautions. . . . .	2
How To Order Repair Parts. . . . .	3
Illustration # 1 - Frame Grouping. . . . .	4
Parts Listing for Frame Grouping . . . . .	5
Illustration # 2 - Arbor & Blade Guard Grouping . . . . .	6
Parts Listing for Arbor & Blade Guard Grouping . . . . .	7
Illustration # 3 - Transmission Grouping . . . . .	8
Parts Listing for Transmission Grouping . . . . .	9
Illustration #4 - Honda Engine Grouping . . . . .	10
Parts Listing for Honda Engine Grouping . . . . .	11
Illustration # 5 - Kohler Engine Grouping . . . . .	12
Parts Listing for Kohler Engine Grouping . . . . .	13
Illustration # 6 - Belt Drive Grouping . . . . .	14
Illustration # 7 - Blade Depth Gauge Grouping . . . . .	15

ILLUSTRATION # 1 : FRAME GROUPING

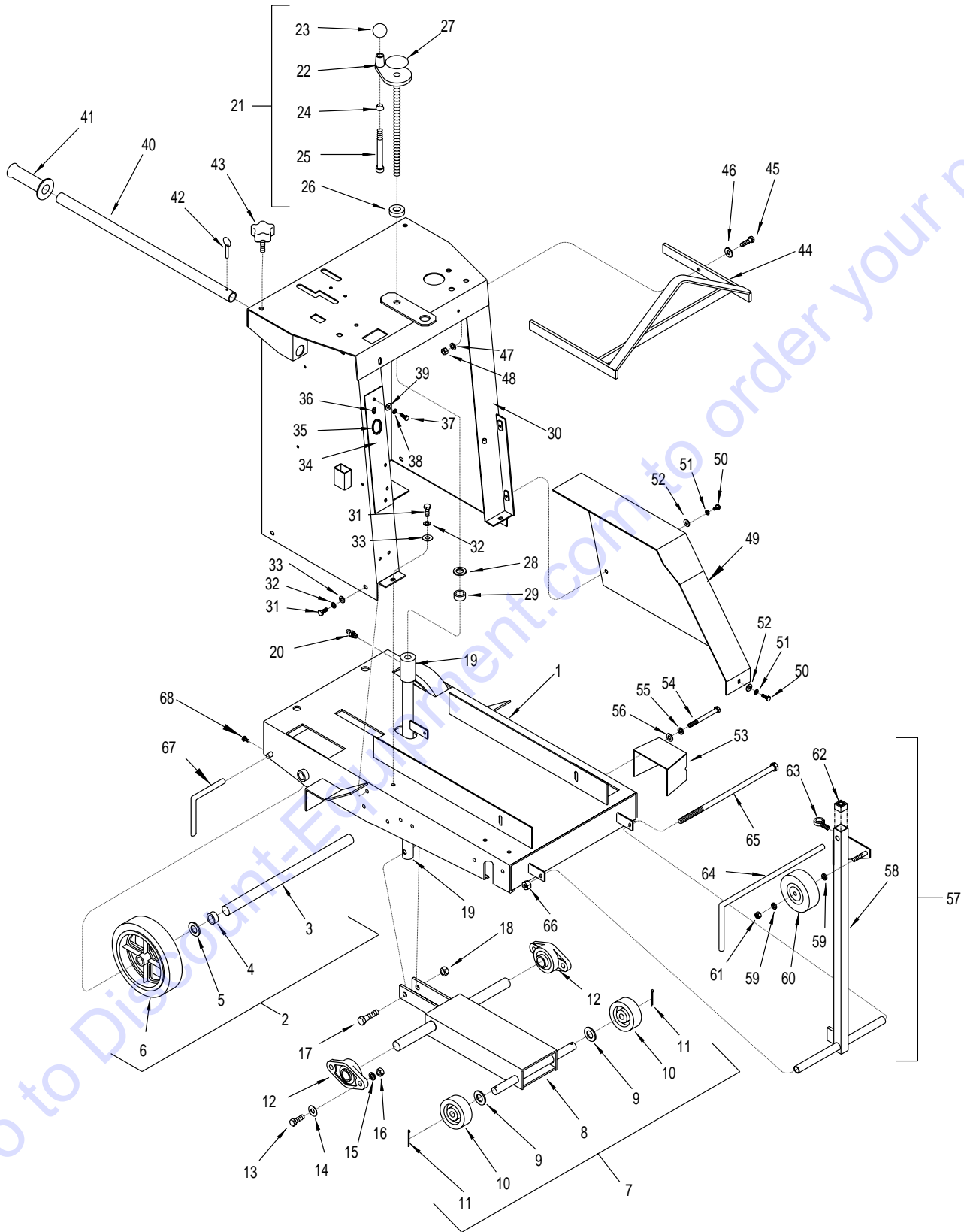

## PARTS LISTING - ILLUSTRATION # 1: FRAME GROUPING

ITEM #	PART #	DESCRIPTION	QTY.	ITEM #	PART #	DESCRIPTION	QTY.
1	51201	MAIN FRAME	1	35	57149	GROMMET 1-1/4" ID x 1/8" GRV. x 1-1/2" GD.	1
2	51219A	AXLE & WHEEL SUBASSEMBLY (ITEMS 3-6)	1	36	57148	GROMMET 3/8" ID x 1/8" GRV. x 5/8" GD	1
3	51219	AXLE SHAFT 3/4 X 19	1	37	10018	SCREW, CAP 1/4-20 x 3/4	2
4	10428	COLLAR, LOCKING 3/4" ID	2	38	10038	WASHER, LOCK 1/4	2
5	10009	WASHER, FLAT 3/4	2	39	10602	WASHER, FLAT 1/4	2
6	51028	WHEEL 8 x 2 x 3/4" BRG.	2	40	51024	HANDLE BAR 24"	2
7	51202A	FORK SUBASSEMBLY (ITEMS 8-12)	1	41	61108	GRIP, HAND 1" MODEL SX	2
8	51202	FORK	1	42	10145	PIN, DETENT RING 3/16 x 1-5/16 EFF. LG.	2
9	10009	WASHER, FLAT 3/4	2	43	51230	KNOB, STAR CLAMPING (3/8-16 x 1 STUD)	2
10	52001	WHEEL 4 x 1-1/2 x 3/4" BRG., ALUM./RUB.	2	44	51204	BAIL, LIFTING	1
11	10306	PIN, COTTER 3/16 x 1-1/4	2	45	10021	SCREW, CAP 3/8-24 x 1	4
12	62022	BEARING, BALL 1" 2-HOLE FLANGE	2	46	10025	WASHER, FLAT 3/8	4
13	10003	SCREW, CAP 7/16-20 x 1-1/4	4	47	10811	WASHER, LOCK 3/8	4
14	10062	WASHER, FLAT 7/16	4	48	10014	NUT 3/8-24	4
15	10450	WASHER, LOCK 7/16	4	49	51205	COVER, BELT	1
16	10481	NUT 7/16-20	4	50	10018	SCREW, CAP 1/4-20 x 3/4	3
17	10347	SCREW, CAP 1/2-20 x 2-1/4	1	51	10038	WASHER, LOCK 1/4	3
18	10205	NUT, LOCK 1/2-20	1	52	10602	WASHER, FLAT 1/4	3
19	51220	LINKAGE, CUT CONTROL	1	53	51206	COVER, ARBOR	1
20	10808	FITTING, GREASE 1/4-28 STRAIGHT	1	54	10318	SCREW, CAP 3/8-16 x 3-3/4	2
21	51075A	HANDWHEEL SUBASSEMBLY (ITEMS 22-27)	1	55	10811	WASHER, LOCK 3/8	2
22	51075	HANDWHEEL, LG. w/ 5/8-8 x 13" ROD	1	56	10025	WASHER, FLAT 3/8	2
23	14023	KNOB, BALL 1-3/8 DIA. w/ 1/2-13 THD.	1	57	56210A	GUIDE BAR SUBASSEMBLY (ITEM 58-64)	1
24	50550	SLEEVE FOR 1/2" CAPSCREW, TAPERED	1	58	56210	GUIDE BAR	1
25	10346	SCREW, SKT. HD. 1/2-13 x 4-1/2	1	59	10025	WASHER, FLAT 3/8	2
26	85005	BEARING, BALL 5/8 ID x 1-1/2 OD, THRUST	1	60	50024	WHEEL 4 x 1-3/8 x 3/8 BORE	1
27	61106	DECAL, CUT CONTROL ( LARGE ) DN/UP	1	61	10004	NUT, LOCK 3/8-24	1
28	10073	WASHER, FLAT 5/8	1	62	51078	PLUG, SQ. TUBE 1 x 14 GA.	1
29	10096	COLLAR, LOCKING 5/8" ID	1	63	51079	BOLT, EYE 3/8-16 x 1 x 5/8" ID	1
30	51203	CONSOLE	1	64	51012	GUIDE POINTER, FRONT	1
31	10053	SCREW, CAP 5/16-18 x 3/4	8	65	10421	SCREW, CAP 1/2-13 x 13	1
32	10801	WASHER, LOCK 5/16	8	66	10407	NUT, LOCK 1/2-13	1
33	10213	WASHER, FLAT 5/16	8	67	51011	GUIDE POINTER, REAR	1
34	51231	CONSOLE FRONT PLATE, RIGHT SIDE	1	68	10834	SCREW, CAP 1/4-20 x 1/2	2

ILLUSTRATION # 2 : ARBOR & BLADE GUARD GROUPING

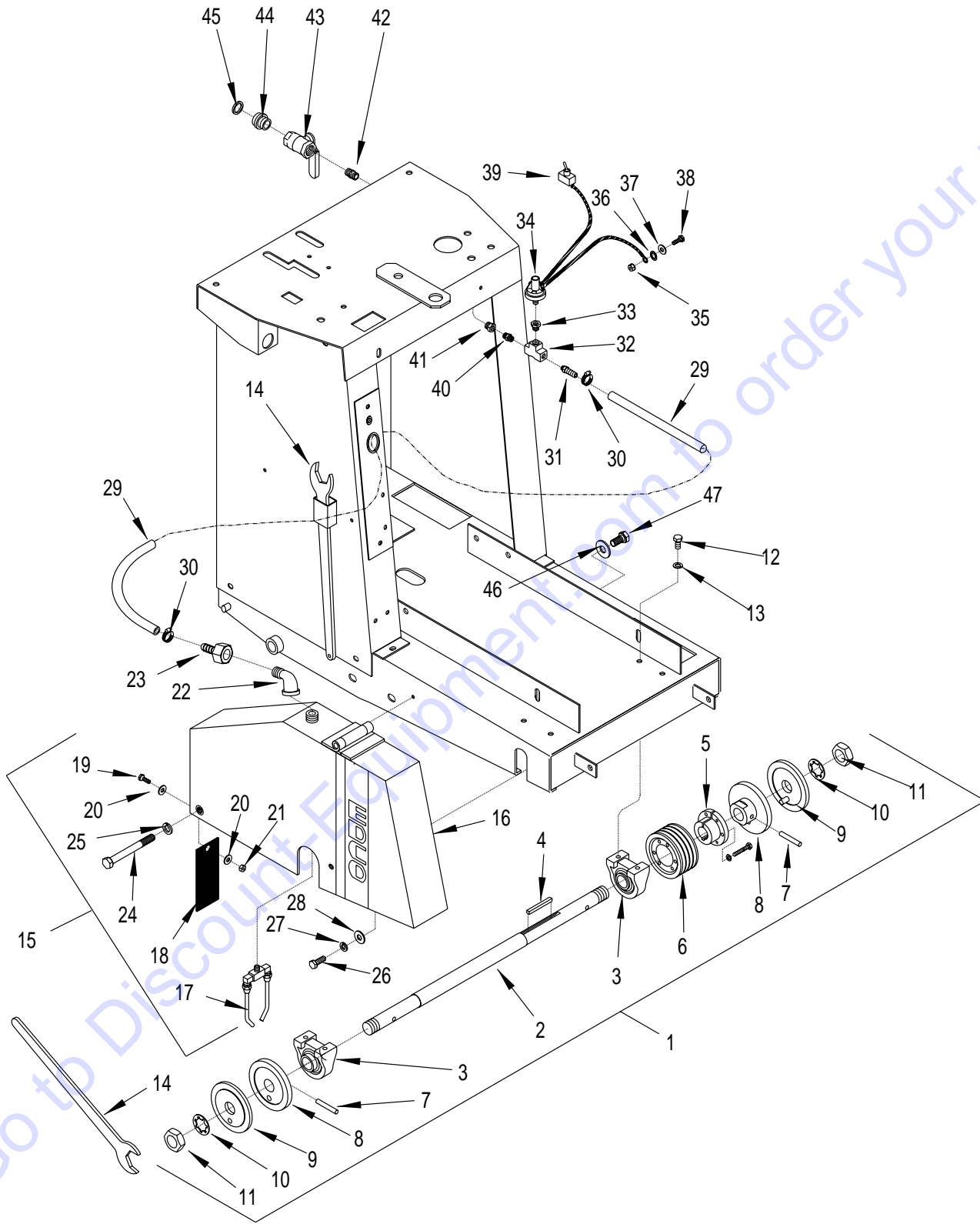



**PARTS LISTING - ILLUSTRATION # 2 : ARBOR & BLADE GUARD GROUPING**

ITEM#	PART #	DESCRIPTION	QTY.	ITEM #	PART #	DESCRIPTION	QTY.
1	56208C	ARBOR SUBASSEMBLY (INCLUDES ITEMS 2 THRU 11)	1	28	10025	WASHER, FLAT 3/8	1
2	56208	ARBOR SHAFT 23-3/8" L	1	29	51222	HOSE, WATER 3/8" ID x 45" L	1
3	50222	BEARING, BALL 1" TAP PILLOW BLOCK	2	30	50069	CLAMP, HOSE, SIZE M6, ADJ. TO 13/16"	2
4	10071	KEY 1/4" SQ. x 2-1/2	1	31	50075	BARB, HOSE 3/8" HOSE x 1/4 MPT	1
5	10076	BUSHING, SHEAVE SH x 1" BORE	1	32	10719	PIPE TEE, FEMALE 1/4 NPT (BRASS)	1
6	10504	SHEAVE 3.65" OD x 4Gr. 3V x SH	1	33	10718	BUSHING, HEX 1/4 x 1/8 NPT (BRASS)	1
7	10211	PIN, ROLL 5/16 x 2	2	34	51030	SWITCH, PRESSURE, MAG. IGN. 76061-2 NC	1
8	56026	ARBOR BACKING PLATE 4" DIA.	2	35	10861	NUT, KEPS 1/4-20	1
9	56025	ARBOR BLADE RETAINING CAP 4" OD w/ 1" HOLE	2	36	10451	WASHER, LOCK, INT. TOOTH 1/4"	1
10	55009	WASHER, LOCK, INTERNAL TOOTH 1"	2	37	10602	WASHER, FLAT 1/4	1
11	50019	NUT, JAM 1-14	2	38	10018	SCREW, CAP 1/4-20 x 3/4	1
12	10907	SCREW, CAP 3/8-16 x 3/4	4	39	10633	SWITCH, TOGGLE SPST	1
13	10811	WASHER, LOCK 3/8	4	40	10717	NIPPLE, HEX 1/4 NPT (BRASS)	1
14	50445	WRENCH, ARBOR 1-1/2	2	41	51236	BUSHING, HEX 1/2 x 1/4 NPT (BRASS)	1
15	51207C	BLADE GUARD SUBASSEMBLY (INCLUDES ITEMS 16 THRU 23)	1	42	10679	NIPPLE, HEX 1/2 NPT (BRASS)	1
16	51207	GUARD, BLADE 18 - 20"	1	43	10711	VALVE, BALL 1/2 FPT	1
17	51026	NOZZLE, COOLANT	1	44	80021	CONN., SWIVEL FEMALE 3/4 HOSE x 1/2 MPT	1
18	41115	RUBBER, FLAP, SPLASH 2-1/2 x 8	1	45	10070	WASHER, HOSE 3/4	1
19	10018	SCREW, CAP 1/4-20 x 3/4	1	46	10312	WASHER, FLAT 1/2	1
20	10602	WASHER, FLAT 1/4	2	47	10304	SCREW, CAP 1/2-20 x 1	1
21	10015	NUT, LOCK 1/4-20	1				
22	10724	ELBOW, STREET 1/2 NPT x 90° (BLACK)	1				
23	10729	BARB, 3/8" HOSE x 1/2 FPT	1				
24	10409	SCREW, CAP 1/2-20 x 4-1/2	1				
25	10045	WASHER, LOCK 1/2	1				
26	10055	SCREW, CAP 3/8-16 x 1	1				
27	10811	WASHER, LOCK 3/8	1				



ILLUSTRATION # 3 : TRANSMISSION GROUPING

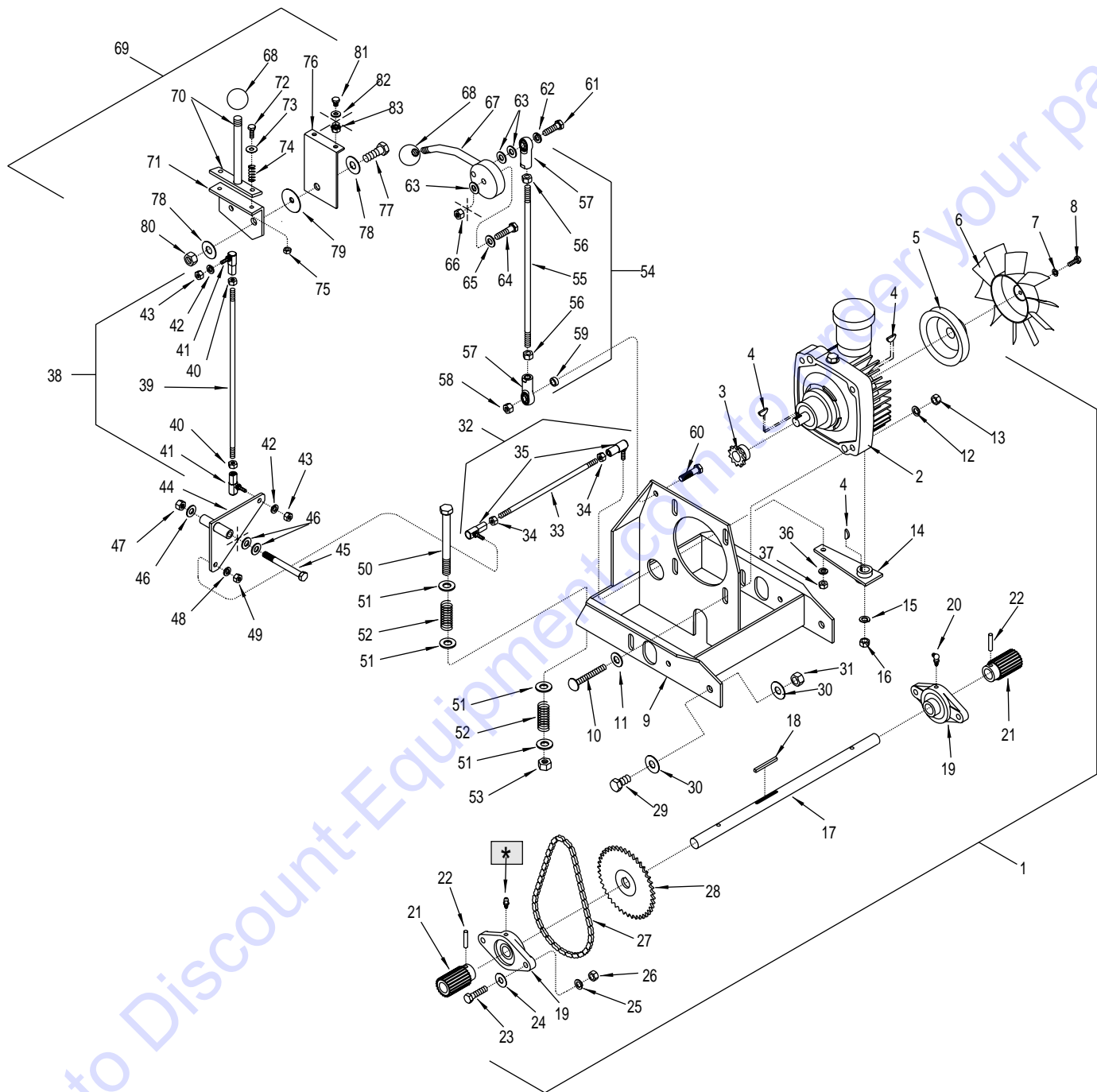

\* STRAIGHT GREASE FITTING INCLUDED w/ BEARING

**PARTS LISTING - ILLUSTRATION # 3: TRANSMISSION GROUPING**

ITEM #	PART #	DESCRIPTION	QTY.	ITEM #	PART #	DESCRIPTION	QTY.
1	51209A	TRANS. SUBASSY. w/ DRIVE SHAFT (ITEMS 2-26)		42	10801	WASHER, LOCK 5/16	2
2	50061	TRANSMISSION, HYDROSTATIC	1	43	10424	NUT, 5/16-24	2
3	50048	SPROCKET #3511 x .67" BORE	1	44	51214	BELL CRANK, DRIVE LINKAGE	1
4	50071	KEY, WOODRUFF 1/8 x 1/2 (#404)	3	45	10382	SCREW, CAP 3/8-24 x 3-1/2	1
5	50062	SHEAVE, HYD. TRANS. 4" OD x 1Gr.x.671B	1	46	10025	WASHER, FLAT 3/8	3
** 6	50266	FAN BLADE w/ PLATE 7", TRANSMISSION	1	47	10004	NUT, LOCK 3/8-24	1
** 7	10038	WASHER, LOCK 1/4	1	48	10801	WASHER, LOCK 5/16	1
** 8	10018	SCREW, CAP 1/4-20 x 3/4	1	49	10424	NUT 5/16-24	1
9	51209	MOUNT, TRANSMISSION	1	50	10376	SCREW, CAP 1/2-13 x 5	2
10	10909	BOLT, CARRIAGE 3/8-16 x 3	4	51	10312	WASHER, FLAT 1/2	8
11	10040	WASHER, GARRET 1" OD x 17/32" ID x .054T	4	52	51035	SPRING, COMP. .828" OD x 2" FL	4
12	10811	WASHER, LOCK 3/8	4	53	10407	NUT, LOCK 1/2-13	2
13	10404	NUT 3/8-16	4	54	51216A	CLUTCH LINKAGE SUBASSY. (ITEMS 55-57)	
14	51223	TRANSMISSION CONTROL ARM	1	55	51216	LINKAGE, ROD 3/8 x 13" L	1
15	10811	WASHER, LOCK 3/8	1	56	10014	NUT, 3/8-24	2
16	10404	NUT 3/8-16	1	57	10919	ROD END, FEMALE 3/8-24	2
17	51217	JACKSHAFT 3/4 X 17" DIA.	1	58	10004	NUT, LOCK 3/8-24	1
18	10168	KEY 3/16" SQ. x 2	1	59	10113	SPACER 9/16 OD x 3/8 ID x 7/32	1
19	50049	BEARING, BALL 3/4" 2-HOLE FLANGE	2	60	10309	SCREW, CAP 3/8-24 x 1-1/4	1
20	10961	GREASE FITTING 1/4-28 x 90	1	61	10309	SCREW, CAP 3/8-24 x 1-1/4	1
21	51218	DRIVER, REAR WHEEL	2	62	10811	WASHER, LOCK 3/8	1
22	10024	PIN, ROLL 1/4" x 1-1/4"	2	63	10025	WASHER, FLAT 3/8	3
23	10816	SCREW, CAP 3/8-24 x 1-1/2	4	64	10816	SCREW, CAP 3/8-24 x 1-1/2	1
24	10025	WASHER, FLAT 3/8	4	65	10025	WASHER, FLAT 3/8	2
25	10811	WASHER, LOCK 3/8	4	66	10004	NUT, LOCK 3/8	1
26	10014	NUT 3/8-24	4	67	51215	LEVER, CLUTCH	1
27	51059	CHAIN, #35 x 22-3/8" LOA	1	68	14023	KNOB, BALL 1-3/8" RD w/ 1/2-13 THD.	2
28	51037	SPROCKET #35B42 x 3/4" BORE	1	69	51210A	DRIVE LEVER SUBASSY. (ITEMS 70-80)	
29	10304	SCREW, CAP 1/2-20 x 1	1	70	51210	LEVER, DRIVE	1
30	10312	WASHER, FLAT 1/2	2	71	51235	PLATE, DRIVE LEVER PRESSURE	1
31	10205	NUT, LOCK 1/2-20	1	72	10905	SCREW, CAP 1/4-20 x 1-1/4	2
32	51213A	LINKAGE SUBASSY., DRIVE HORIZ. (ITEMS 33-35)		73	10602	WASHER, FLAT 1/4	2
33	51213	LINKAGE, ROD 5/16 x 9" L	1	74	50609	SPRING, COMP., .437 OD x 1" FL.	2
34	10446	NUT 5/16-24	2	75	10015	NUT, LOCK 1/4-20	2
35	10840	BALL JOINT ASSY. w/ DIRT SHIELD 5/16-24	2	76	51211	MOUNT BRACKET, DRIVE LEVER	1
36	10801	WASHER, LOCK 5/16	1	77	10304	SCREW, CAP 1/2-20 x 1	1
37	10446	NUT, LOCK 5/16-24	1	78	10312	WASHER, FLAT 1/2	2
38	51212A	LINKAGE SUBASSY., DRIVE VERT. (ITEMS 39-41)		79	50428	WASHER, FIBER, 2-1/4 x 1/2 x 1/8	1
39	51212	LINKAGE, ROD 5/16 x 13-5/8" L	1	80	10205	NUT, LOCK 1/2-20	1
40	10446	NUT 5/16-24	2	81	10018	SCREW, CAP 1/4-20 x 3/4	2
41	10840	BALL JOINT ASSY. w/ DIRT SHIELD 5/16-24	2	82	10602	WASHER, FLAT 1/4	2
		** NOT PART OF SUBASSEMBLY		83	10861	NUT, KEPS 1/4	2

ILLUSTRATION # 4 : HONDA ENGINE GROUPING

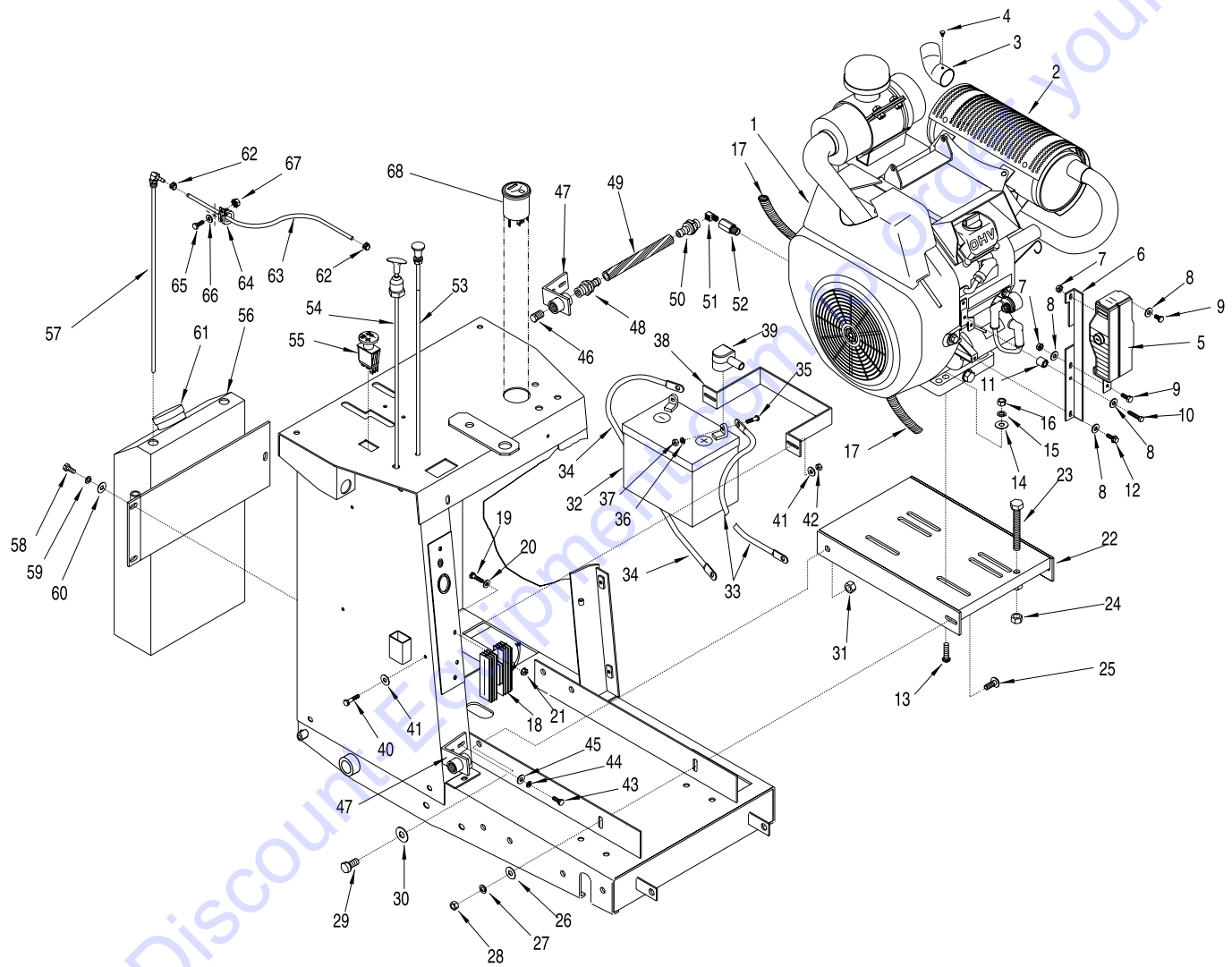

### PARTS LISTING - ILLUSTRATION # 4: HONDA ENGINE GROUPING

ITEM #	PART #	DESCRIPTION	QTY.	ITEM #	PART #	DESCRIPTION	QTY.
1	15038	ENGINE, HONDA, 20HP	1	35	10818	BOLT, CARRIAGE 5/16-18 x 3/4	2
2	15132	MUFFLER VHRM 1	1	36	10811	WASHER, LOCK 5/16	2
3	51224	ELBOW, SOLDER JOINT 1-1/4 x 45°	1	37	10054	NUT 5/16-18	2
4	10877	SCREW, SELF-TAP HEX WASHER 10-24 x 1/2	1	38	50091	CLAMP, BATTERY HOLD-DOWN	1
5	-----	ENGINE, IGNITION BOX (INCL.w/ ENG.)	1	39	10928	INSULATOR, BAT.TERM. POS. (RED)	1
6	51227	MOUNT, ENGINE IGNITION BOX	1	40	10905	SCREW, CAP 1/4-20 x 1"	2
7	10861	NUT, KEPS 1/4-20	2	41	10602	WASHER, FLAT 1/4	4
8	10602	WASHER, FLAT 1/4"	4	42	10150	NUT, NYLON LOCK 1/4-20	2
9	10834	SCREW, CAP 1/4-20 x 1/2	2	43	10018	SCREW, CAP 1/4-20 x 3/4	2
10	51229	SCREW, CAP M6 x 30mm	1	44	10038	WASHER, LOCK 1/4	2
11	51228	SPACER, STEEL 3/8ID x 5/8OD x 5/8L	1	45	10602	WASHER, FLAT 1/4	2
12	-----	SCREW, 6mm (INCL. w/ ENGINE)	1	46	50552	PLUG, PIPE 1/2" NPT (BRASS)	1
13	10087	BOLT, CARRIAGE 3/8-16 x 1-3/4	4	47	57159	BRACKET, OIL DRAIN	1
14	10025	WASHER, FLAT 3/8	4	48	80061	BARB, PUSH-ON, 1/2" HOSE x 1/2 MPT	1
15	10811	WASHER, LOCK 3/8	4	49	51237	HOSE, PUSH-ON 1/2" ID x 7" L	1
16	10404	NUT 3/8-16	4	50	10581	BARB, PUSH-ON, 1/2" HOSE x 1/4 MPT	1
17	51242	LOOM, WIRE FLEX 5/8 x 55"	1	51	10730	ELBOW, 90° STREET 1/4 NPT	1
18	-----	RECTIF./REGULATOR (INCL.w/ ENG.)	1	52	11533	FITTING, ADAPTER G-M14 x 1.5 to 1/4-18 NPT	1
19	10031	SCREW, CAP 1/4-20 x 1	2	53	15129	CABLE, CHOKE 72" (TRIM TO 23")	1
20	10602	WASHER, FLAT 1/4	2	54	51081	CABLE, TURN-TO-LOCK CONTROL 72" (TRIM TO 23")	1
21	10861	NUT, KEPS 1/4-20	2	55	51228	SWITCH, EMERGENCY STOP	1
22	51208	MOUNT, ENGINE	1	56	51221	GAS TANK, 3 GAL. (INCL. ITEM # 61)	1
23	10392	BOLT, TAP 1/2-13 x 4 (FULL THREAD)	1	57	61058	TUBE, FUEL PICK-UP, 19"	1
24	10417	NUT 1/2-13	1	58	10053	SCREW, CAP 5/16-18 x 3/4	3
25	10802	BOLT, CARRIAGE 3/8-16 x 1	2	59	10801	WASHER, LOCK 5/16	3
26	10025	WASHER, FLAT 3/8	2	60	10213	WASHER, FLAT 5/16	3
27	10811	WASHER, LOCK 3/8	2	61	61056	CAP, GAS TANK	1
28	10404	NUT 3/8-16	2	62	10762	CLAMP, HOSE SPRING-TYPE 3/8" (GREEN)	2
29	10304	SCREW, CAP 1/2-20 x 1"	2	63	51241	HOSE, FUEL 1/4" x 34" L	1
30	10312	WASHER, FLAT 1/2	2	64	11565	CLAMP, LOOM 5/8"	1
31	10205	NUT, LOCK 1/2-20	2	65	10018	SCREW, CAP 1/4-20 x 3/4	1
32	84011	BATTERY, 12 VOLT/300 CCA	1	66	10602	WASHER, FLAT 1/4	1
33	61064	CABLE, EYE-EYE 4Ga.x40"RED(POS.)	1	67	10861	NUT, KEPS 1/4-20	1
34	51233	CABLE, EYE-EYE 4Ga.x 20"BLACK (NEG.)	1	68	10637	METER, HOUR 2-1/16"	1

ILLUSTRATION # 5 : KOHLER ENGINE GROUPING

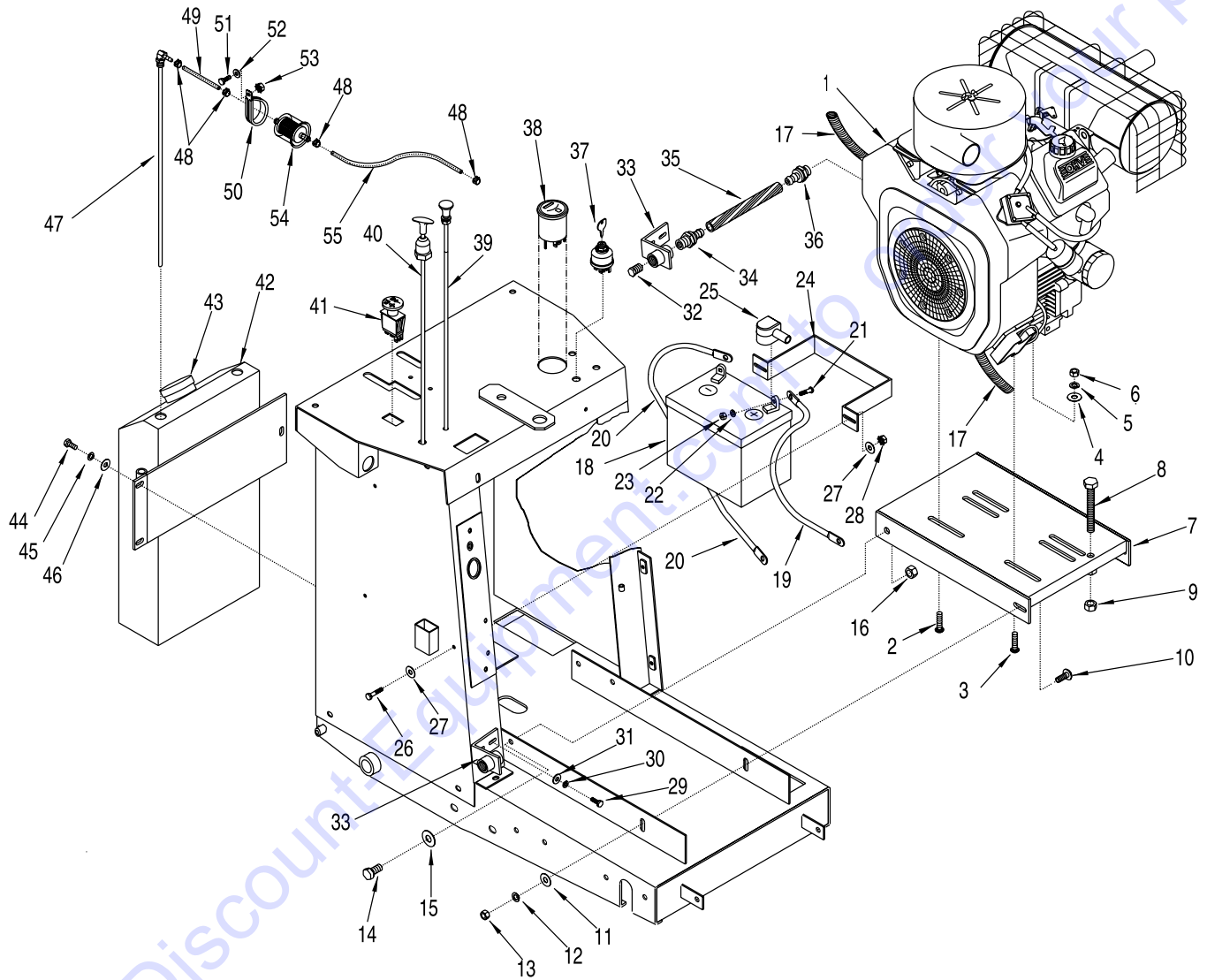

**PARTS LISTING - ILLUSTRATION # 5: KOHLER ENGINE GROUPING**

ITEM #	PART #	DESCRIPTION	QTY.	ITEM #	PART #	DESCRIPTION	QTY.
1	15037	ENGINE, KOHLER COMMAND 20HP	1	37	10650	SWITCH, KEY, KOHLER	1
2	10917	BOLT, CARRIAGE 3/8-16 x 2	1	38	10637	METER, HOUR 2-1/16'	1
3	10087	BOLT, CARRIAGE 3/8-16 x 1-3/4	3	39	15129	CABLE, CHOKE 72" (TRIM TO 30")	1
4	10025	WASHER, FLAT 3/8	2	40	51081	CABLE, TURN-TO-LOCK CONTROL 72"	1
5	10811	WASHER, LOCK 3/8	4			(TRIM TO 32")	1
6	10404	NUT 3/8-16	4	41	51225	SWITCH, EMERGENCY STOP	1
7	51208	MOUNT, ENGINE	1	42	51221	GAS TANK, 3 GAL.(INCL. ITEM # 43)	1
8	10392	BOLT, TAP 1/2-13 x 4 (FULL THREAD)	1	43	61056	CAP, GAS TANK	1
9	10417	NUT 1/2-13	1	44	10053	SCREW, CAP 5/16-18 x 3/4	3
10	10802	BOLT, CARRIAGE 3/8-16 x 1	2	45	10801	WASHER, LOCK 5/16	3
11	10025	WASHER, FLAT 3/8	2	46	10213	WASHER, FLAT 5/16	3
12	10811	WASHER, LOCK 3/8	2	47	61058	TUBE, FUEL PICK-UP, 19"	1
13	10404	NUT 3/8-16	2	48	10762	CLAMP, HOSE SPRING-TYPE 3/8"(GREEN)	4
14	10304	SCREW, CAP 1/2-20 x 1"	2	49	51245	HOSE, FUEL 1/4"ID x 11" L	1
15	10312	WASHER, FLAT 1/2	2	50	11566	CLAMP, LOOM 1-3/4"	1
16	10205	NUT, LOCK 1/2-20	2	51	10018	SCREW, CAP 1/4-20 x 3/4	1
17	51243	LOOM, WIRE FLEX 5/8 x 52"	1	52	10602	WASHER, FLAT 1/4	1
18	84011	BATTERY, 12 VOLT/ 300 CCA	1	53	10861	NUTS, KEPS 1/4-20	1
19	51232	CABLE, EYE-EYE 4Ga.x36" RED(POS.)	1	54	15116	FILTER, FUEL 1/4" IN LINE	1
20	51233	CABLE, EYE-EYE 4Ga.x20"BLCK(NEG.)	1	55	51246	HOSE, FUEL 1/4" ID x 15'L	1
21	10818	BOLT, CARRIAGE 5/16-18 x 3/4	2				
22	10801	WASHER, LOCK 5/16	2				
23	10054	NUT 5/16-18	2				
24	50091	CLAMP, BATTERY HOLD-DOWN	1				
25	10928	INSULATOR, BAT. TERM. POS. (RED)	1				
26	10031	SCREW, CAP 1/4-20 x 1"	2				
27	10602	WASHER, FLAT 1/4	4				
28	10150	NUT, HEX NYLON LOCK 1/4-20	2				
29	10018	SCREW, CAP 1/4-20 x 3/4	2				
30	10038	WASHER, LOCK 1/4"	2				
31	10602	WASHER, FLAT 1/4"	2				
32	50552	PLUG, PIPE 1/2" NPT (BRASS)	1				
33	57159	BRACKET, OIL DRAIN	1				
34	80061	BARB, PUSH-ON, 1/2 HOSE x 1/2 MPT	1				
35	51244	HOSE, PUSH-ON 1/2" ID x 9 1/2" L	1				
36	50554	BARB, PUSH-ON, 1/2" HOSE x 3/8 MPT	1				

### ILLUSTRATION # 6 : BELT DRIVE GROUPING

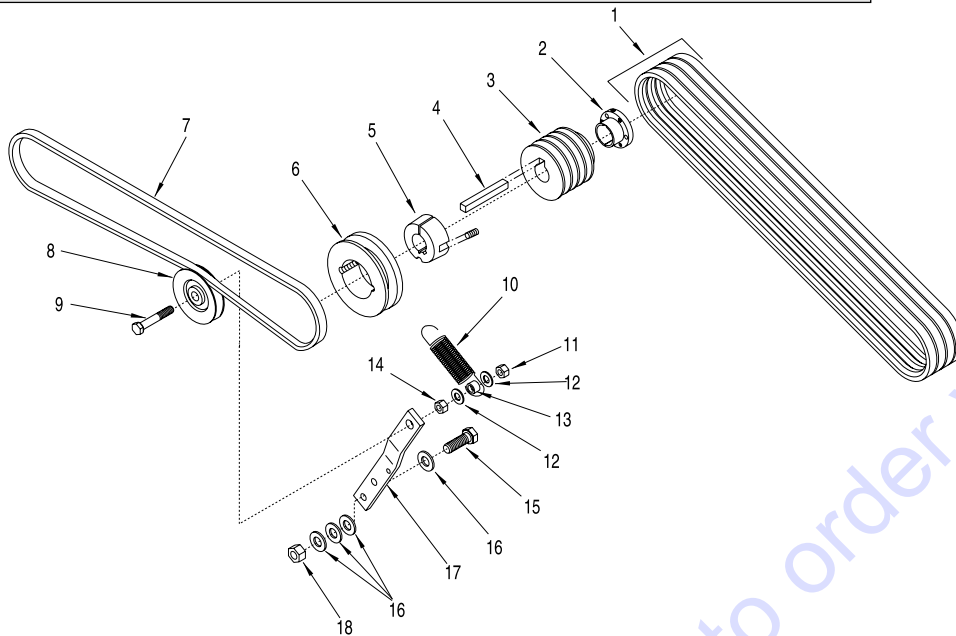

ITEM #	PART #	DESCRIPTION	QTY.
1	10201	BELT, 3VX-335 (REFER TO NAME PLATE ON MACHINE)	4
2	10533	BUSHING, SHEAVE JA x 1-1/8" BORE (HONDA ONLY)	1
3	64037	SHEAVE 2.8"OD x 4 Gr. 3V x JA (HONDA)	1
	64036	SHEAVE 2.8"OD x 4Gr.3V x 1-7/16"B (KOHLER)	
4	-----	KEY, INCLUDED w/ BUSHING (HONDA)	1
	51247	KEY 3/8" SQ. x 3 (KOHLER)	1
5	10529	BUSHING, SHEAVE TAPER-LOCK, <span style="border: 1px solid black; padding: 2px;">HONDA 1-1/8" BORE</span>	1
	10531	BUSHING, SHEAVE TAPER-LOCK, <span style="border: 1px solid black; padding: 2px;">KOHLER 1-7/16" BORE</span>	1
6	10528	SHEAVE, 4.15" OD x 1 Gr.AB x TAPER-LOCK	1
7	51234	BELT A-47 (HONDA-REFER TO NAME PLATE ON MACH.)	1
	10203	BELT A-46 (KOHLER-REFER TO NAME PLATE ON MACH.)	1
8	51226	PULLEY, IDLER 3.125" x 3/4" FLAT x 3/8" BRG.	1
9	10336	SCREW, CAP 3/8-24 x 2-1/4	1
10	50074	SPRING, EXT. 1" OD x 3-15/16" INSIDE ENDS	1
11	10004	NUT, LOCK 3/8-24	1
12	10025	WASHER, FLAT 3/8	2
13	10113	SPACER, STEEL 9/16" OD x 3/8" ID x 7/32"	1
14	10014	NUT 3/8-24	1
15	10308	SCREW, CAP 1/2-20 x 1-1/2	1
16	10312	WASHER, FLAT 1/2	3
17	51052	IDLER ARM	1
18	10205	NUT, LOCK 1/2-20	1

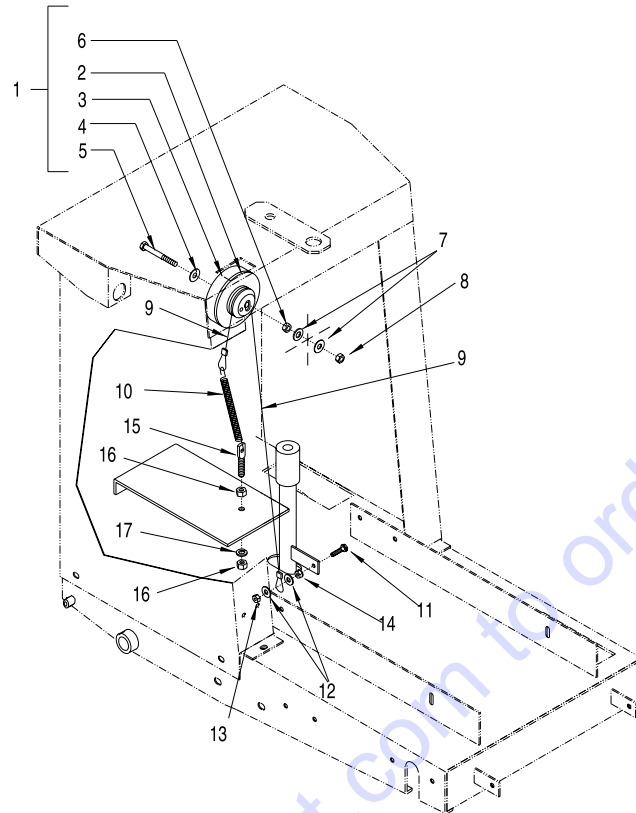

**ILLUSTRATION # 7 : BLADE DEPTH GAUGE GROUPING**

ITEM #	PART #	DESCRIPTION	QTY.
1	51238	DEPTH GAUGE SUBASSEMBLY ( ITEMS 2 - 6 )	1
2	57132	WHEEL, DEPTH GAUGE	1
3	51239	STICKER, DEPTH GAUGE	1
4	10025	WASHER, FLAT 3/8	1
5	10336	SCREW, CAP 3/8-24 x 2-1/4	1
6	10004	NUT, LOCK 3/8-24	1
7	10025	WASHER, FLAT 3/8	2
8	10150	NUT, HEX NYLON LOCK 3/8-24	1
9	51240	CABLE, DEPTH GAUGE 3/32 x 25" L	1
10	3636	SPRING, EXT. 6" L	1
11	10031	SCREW, CAP 1/4-20 x 1	1
12	10602	WASHER, FLAT 1/4	2
13	10015	NUT, LOCK 1/4-20	1
14	10861	NUT, KEPS 1/4"	1
15	10843	BOLT, SPADE 3/8-16 X 1- 5/8	1
16	10404	NUT 3/8-16	1
17	10811	WASHER, LOCK 3/8	1

# PARTS FINDER

**Search Website  
by Part Number**



**Search Manual  
Library For Parts  
Manual & Lookup Part  
Numbers – Purchase  
or Request Quote**

**Search Manuals**

Enter your information to help us find the right parts manual for your machine.

\* Brand:

\* Model:

\* Serial:

\* Part Number:

SEARCH

**Can't Find Part or  
Manual? Request Help  
by Manufacturer,  
Model & Description**

**Parts Order Form**

Please fill in the following information to help us find the right part for your machine.

MANUFACTURER:

MODEL:

DESCRIPTION:

SEARCH

Discount-Equipment.com is your online resource for quality parts & equipment.

Florida: **561-964-4949** Outside Florida TOLL FREE: **877-690-3101**

**Need parts?**

Click on this link: <http://www.discount-equipment.com/category/5443-parts/> and choose one of the options to help get the right parts and equipment you are looking for. Please have the machine model and serial number available in order to help us get you the correct parts. If you don't find the part on the website or on one of the online manuals, please fill out the request form and one of our experienced staff members will get back to you with a quote for the right part that your machine needs.

We sell worldwide for the brands: Genie, Terex, JLG, MultiQuip, Mikasa, Essick, Whiteman, Mayco, Toro Stone, Diamond Products, Generac Magnum, Airman, Haulotte, Barreto, Power Blanket, Nifty Lift, Atlas Copco, Chicago Pneumatic, Allmand, Miller Curber, Skyjack, Lull, Skytrak, Tsurumi, Husquvarna Target, Stow, Wacker, Sakai, Mi-T-M, Sullair, Basic, Dynapac, MBW, Weber, Bartell, Bennar Newman, Haulotte, Ditch Runner, Menegotti, Morrison, Contec, Buddy, Crown, Edco, Wyco, Bomag, Laymor, EZ Trench, Bil-Jax, F.S. Curtis, Gehl Pavers, Heli, Honda, ICS/PowerGrit, IHI, Partner, Imer, Clipper, MMD, Koshin, Rice, CH&E, General Equipment, Amida, Coleman, NAC, Gradall, Square Shooter, Kent, Stanley, Tamco, Toku, Hatz, Kohler, Robin, Wisconsin, Northrock, Oztec, Toker TK, Rol-Air, APT, Wylie, Ingersoll Rand / Doosan, Innovatech, Con X, Ammann, Mecalac, Makinex, Smith Surface Prep, Small Line, Wanco, Yanmar