

⚠ Read this handbook thoroughly and understand the whole information contained before trying to operate, inspect and service your machine!

**OPERATING &  
MAINTENANCE  
INSTRUCTIONS**

**VIBRATING  
ROLLER**

**MODEL**

**CR271**

From CR271 → 4CR2 - 20213

「For EPA regulated areas」

**TO PURCHASE THIS PRODUCT PLEASE CONTACT US**



**Equipment Financing and  
Extended Warranties Available**



**Discount-Equipment.com is your online resource for  
commercial and industrial quality parts and equipment sales.**

**561-964-4949**

**visit us on line @ [www.discount-equipment.com](http://www.discount-equipment.com)**

Select an option below to find your Equipment

**Search by Manufacturer**

**Search by Product Type**

**Request a Quote**

We sell worldwide for the brands: Genie, Terex, JLG, MultiQuip, Mikasa, Essick, Whiteman, Mayco, Toro Stone, Diamond Products, Generac Magnum, Airman, Haulotte, Barreto, Power Blanket, Nifty Lift, Atlas Copco, Chicago Pneumatic, Allmand, Miller Curber, Skyjack, Lull, Skytrak, Tsurumi, Husquvarna Target, Stow, Wacker, Sakai, Mi-T-M, Sullair, Basic, Dynapac, MBW, Weber, Bartell, Bennar Newman, Haulotte, Ditch Runner, Menegotti, Morrison, Contec, Buddy, Crown, Edco, Wyco, Bomag, Laymor, EZ Trench, Bil-Jax, F.S. Curtis, Gehl Pavers, Heli, Honda, ICS/PowerGrit, IHI, Partner, Imer, Clipper, MMD, Koshin, Rice, CH&E, General Equipment, Amida, Coleman, NAC, Gradall, Square Shooter, Kent, Stanley, Tamco, Toku, Hatz, Kohler, Robin, Wisconsin, Northrock, Oztec, Toker TK, Rol-Air, APT, Wylie, Ingersoll Rand / Doosan, Innovatech, Con X, Ammann, Mecalac, Makinex, Smith Surface Prep, Small Line, Wanco, Yanmar

## PREFACE

This operator's manual serves as a guide for the use of your Sakai Vibrating Rollers CR271 for those who are new to the machine, and also for the people who have experience in using the Machine and want to refresh their knowledge for the machine.

Read this manual thoroughly and try to fully understand the information before operating your machine. Keep this handbook at hand whenever you do your work.

The main subjects of this manual are:

(1) Basic precautions for safety, (2) Operation, (3) Daily maintenance and (4) Specifications. For operation and maintenance of the engine, refer to the Engine Instruction Manual furnished separately. Descriptions in this manual can differ from the machine instructions of your machine due to the results of the investigation and improvement in its design. If you have any inquiry regarding your Machine or this manual, contact Discount-equipment.

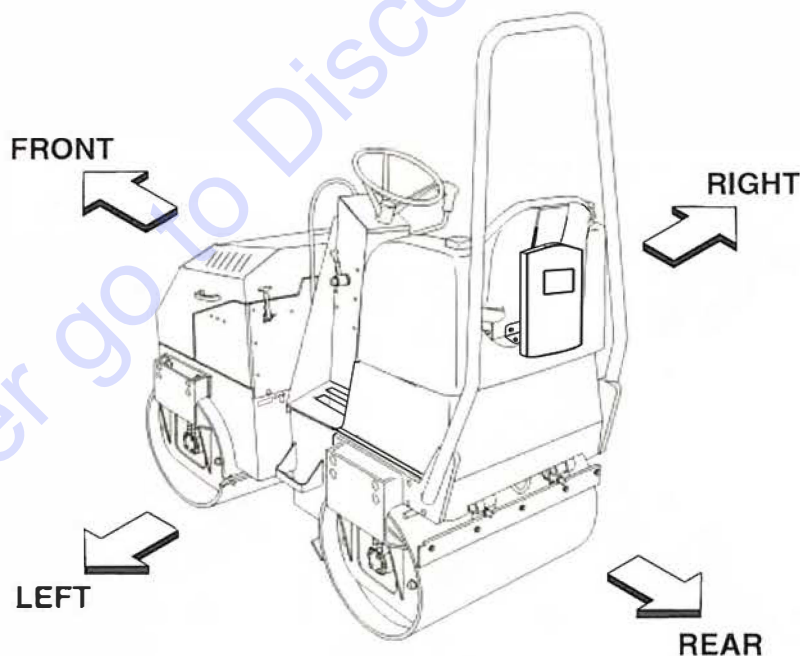

CR271

## CONTENTS

## PREFACE

MACHINE AND ENGINE IDENTIFICATION NUMBERS .....	1
EMISSION CONTROL INFORMATION .....	2
SAFETY NOTICES .....	2
1. BASIC PRECAUTIONS FOR SAFETY .....	4
1.1 General Precautions .....	4
1.2 Preparation for Safe Operation .....	6
1.3 Before Starting the Engine .....	7
1.4 After Starting the Engine .....	8
1.5 During Operation .....	8
1.6 Loading and Unloading .....	10
1.7 Transportation .....	11
1.8 Handling the Battery .....	11
1.9 Towing .....	12
1.10 Before Servicing .....	13
1.11 During Servicing .....	14
1.12 Safety Decals .....	16
2. OPERATION .....	18
2.1 Instruments and Controls .....	18
2.1.1 Operator's station .....	18
2.1.2 Gauges and warning lamps .....	19
2.1.3 Switches .....	20
2.1.4 Operating levers and knob .....	22
2.1.5 Fuse .....	24
2.2 Handling and Adjustments .....	24
2.2.1 Scraper adjustment and replacement .....	24
2.3 Operation .....	25
2.3.1 Before-starting inspection .....	25
2.3.2 Starting the engine .....	26
2.3.3 After starting the engine .....	27
2.3.4 Traveling .....	28
2.3.5 Stopping / Parking .....	29
2.3.6 Stopping the engine .....	29
2.3.7 Check after stopping the engine .....	30

2.4	Vibratory Operation .....	31
2.5	Sprinkler .....	32
2.6	Precautions for Work .....	33
2.6.1	Compaction operation .....	33
2.6.2	When going downhill .....	33
2.6.3	On a slope .....	33
2.7	Applicable Jobs .....	33
2.8	After Operation .....	34
2.9	Loading and Unloading .....	35
2.9.1	Use of a trailer equipped with a winch .....	35
2.9.2	Self-propelling .....	36
2.9.3	Use of a mobile crane .....	37
2.10	After Loading the Machine .....	37
2.11	Transportation .....	38
2.12	Operation in Cold Weather .....	38
2.12.1	Fuel oil and grease .....	38
2.12.2	Battery .....	38
2.13	When the Cold Season is Over .....	38
2.14	For a Long Storage Period .....	39
2.15	During the Storage period .....	39
2.16	When the Battery Has Discharged .....	40
2.16.1	Connection and disconnection of booster cables .....	40
3.	PERIODICAL MAINTENANCE .....	42
3.1	Precautions .....	42
3.2	Walk-around Checking .....	43
3.3	Periodical Maintenance points .....	44
3.4	Maintenance Procedure .....	46
(1)	Every 10 hours or daily .....	46
(2)	Every 50 hours .....	46
(3)	Every 100 hours .....	47
(4)	Every 250 hours .....	48
(5)	Every 500 hours .....	49
(6)	As required .....	49
3.5	Feeding Water and Lubricants .....	51
3.6	Electric Wiring Diagram .....	53
4.	SPECIFICATIONS .....	55

## MACHINE AND ENGINE IDENTIFICATION NUMBERS

When ordering parts or making inquiries about your machine, the following information is requested:

### (1) Machine model

Indicated on the dashboard in the operator's station.

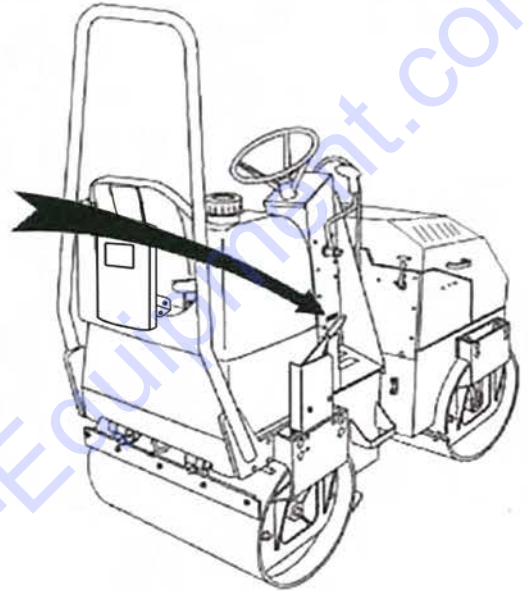

### (2) Machine serial number

CR271 ⇒ 4CR2 - 00000

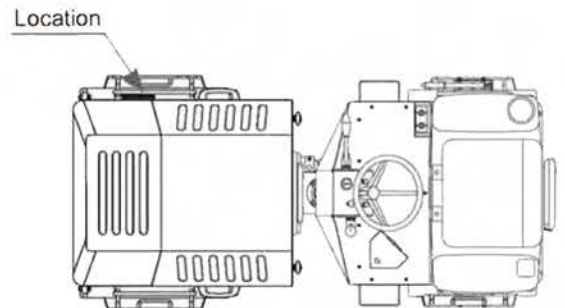



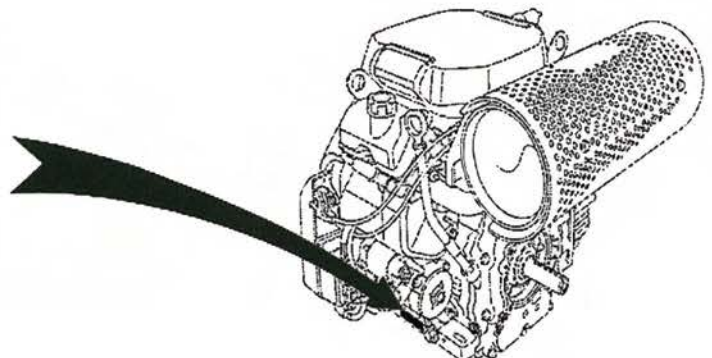
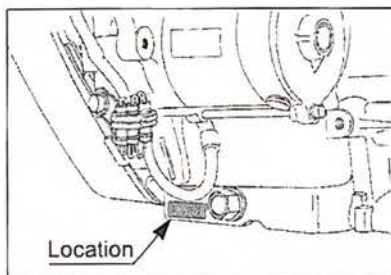



### (3) Engine serial number





This manual covers the proper and safe method of driving and handling of this machine for its intended use. When this machine is used in a manner, other than that covered in this manual, you must assume responsibility for your own personal safety.

In this manual and on the machine, you will find safety notices. Each safety notice starts with a signal word as shown below:

-  **DANGER** Denotes that there is an extreme hazard. If you fail to take proper precautions, it is highly likely that you could be killed or seriously injured (The color of the symbol  is red).
-  **WARNING** Denotes that there is a hazard. If you fail to take proper precautions, you could be killed or seriously injured (Symbol  is orange).
-  **CAUTION** Calls attention to safety practices. If you fail to take proper precautions, you could be injured or cause damage to the machine (Symbol  is yellow).

It is almost impossible for the safety notices in this manual and on the machine to cover all the potential dangers. Keep alert to possible dangers not mentioned in this manual and on the decals.

 **WARNING**

**Do not operate your machine before you read its operator's manual thoroughly.**

**Incorrect operation can kill or cause injury.**

**It is your responsibility to operate the machine safely.**

☆ Non-approved modifications can pose safety-related problems. Before making any modifications, consult Discount-equipment. For an injury or damage to the machine caused by non-approved modifications, Sakai accepts no responsibility.

☆ Basic precautions for safe operation of your machine are discussed beginning on page 4.

☆ To operate and work with your machine, you must be qualified.



## 1. BASIC PRECAUTIONS FOR SAFETY

### 1. BASIC PRECAUTIONS FOR SAFETY

#### 1.1 General Precautions

■ **Read thoroughly the operator's manual.**

- Understand the functions of the controls and gauges. Familiarize yourself with their location and how to operate them. Understand the meaning of all the symbols.



■ **Obey the worksite rules.**

- Follow the worksite rules such as matters forbidden or to be attended to, and working procedures.

■ **Wear protective clothing to suit the work.**

- Wear clothing, safety shoes and hard hat to suit your work.
- Do not wear clothing and accessories that tend to get caught in the controls or protruded portions of the machine. Do not wear oily clothing.
- According to the type of jobs, wear safety goggles or mask.



■ **Know the work area in advance.**

- Know the terrain, geology and conditions of the road surface at the worksite. Start working after securing safety such as stationing a guardsman or putting up barriers where there is a risk of falling of the machine or collapse of shoulder.

■ **Provide against an accident.**

- Decide in advance the means of communication in an emergency. Know the location and use of an extinguisher and first-aid kit.

■ **Know the capability of the machine.**

- Thoroughly understand the performance of your machine and correctly operate the machine to meet the requirements of the job site. Operating the machine beyond its capabilities may lead to an accident. Use your machine within its capability.
- The machines which have not attached ROPS must not be operated on the slopes or unsafe ground.
- The machines which have not attached CABIN must not be operated at the bad weather or a harmful contaminated zone.

▲ **WARNING:** Negligence of these instructions can lead to accidents.

## 1. BASIC PRECAUTIONS FOR SAFETY

■ **Do not use a machine which has not been serviced correctly at regular intervals.**

- Before working, perform necessary inspections. Start operation only after making certain the machine is in good operating condition. If found to be abnormal, report to the responsible person and have the fault corrected. Operate the machine after making sure that it is safe to operate.

■ **Do not allow anyone to enter the work area except for authorized personnel.**

- Always conduct the work paying attention to the workers around the machine.



■ **Be careful of hot parts.**

- After your machine has operated for some time, the coolant, engine oil and hydraulic fluid will become hot and the pressure will build up. If, in this state, you try to remove the filler caps, drain the oil or replace the filters, you can get burned. Perform this work in accordance with the correct procedures with the machine cooled down.
- To remove the radiator cap, slowly loosen the cap to relieve the pressure with the engine shut down and the coolant cooled down. (For the radiator cap with a lever, lift the lever to release the trapped pressure.)
- When removing the filler cap on the hydraulic tank, release the trapped pressure by turning it out slowly to prevent the oil from gushing out.
- Do not touch the muffler while the engine is running or immediately after it has been shut down. You can get burned.



■ **Be careful with fire.**

- The fuel, oil, and anti-freeze will catch fire if open flames or ignition sources are used close to them. Particularly, the fuel is highly flammable.



- Do not smoke or use a match or cigarette lighter close to inflammables (combustibles).
- When refueling, stop the engine and do not smoke.
- The filler caps of the fuel and oil tanks must be kept tight.



⚠ **WARNING:** Negligence of these instructions can lead to accidents.

## 1. BASIC PRECAUTIONS FOR SAFETY

### ■ **Mount on or dismount from your machine after it has come to a complete stop.**

- For getting on and off, face the machine and use the handrail and step.
- Do not jump on or off a machine, particularly when it is moving.

### ■ **To handle the hydraulic fluid.**

- Wear safety goggles to protect your eyes from contact with hydraulic fluid. It can irritate your eyes.  
If the fluid contacts your eyes, flush with clean water for 15 minutes and get medical aid.
- The fluid can also irritate your skin. When handling it, wear rubber gloves to avoid contact with it. In case of skin contact, wash with soap and water.
- Be careful not to swallow the fluid. It can cause diarrhea and emesis.  
If swallowed, do not try to vomit. Get medical help immediately.



## 1.2 Preparation for Safe Operation

### ■ **Clean the step, operator's station and floor board.**

- Do not place parts, tools or unnecessary articles on the step, operator's station and floor board.
- Keep the step, floor board, controls and handholds free from muds, oil, ice or water, as they can cause slippage. Repair them if found to be damaged. Tighten loose bolts.
- Keep your boot soles free of oil or muds. They can slip, leading to an accident.

### ■ **Inspect your machine before operation**

- Check your machine for damage such as cracks and deformation. If found to be abnormal, operate the machine after taking a proper measure to secure safety.
- Check the level of fluids (fuel, engine oil, hydraulic oil and sprinkler water). Add as necessary.
- Check the area where the machine has parked for signs of leakage of oil, fuel and water. If any leakage is noticeable, determine the cause and make corrections immediately.

**⚠ WARNING:** Negligence of these instructions can lead to accidents.

## 1. BASIC PRECAUTIONS FOR SAFETY

### ■ Know the stopping distance.

- When traveling on a road, bear in mind the stopping distance. Avoid excessive speed, and abrupt starting and stopping, and moving in a zigzag direction.



### 1.3 Before Starting the Engine

#### ■ Adjust the operator's seat to your most effective operating position.

- Sit on the operator's seat. Adjust the seat so that your back will make contact with the seat back when the brake pedal is depressed to the full extent. Check to be sure that the brake pedal can be fully depressed without difficulty when you twist your body for reverse run.

#### ■ Check that the horn, lamps and gauges work correctly.

#### ■ Before starting, make certain that each lever is in the neutral position and the parking brake is applied.

#### ■ When starting, sound the horn.

- Before starting the engine. Make sure there is no one in the immediate vicinity and there are no obstructions around the machine.



**⚠ WARNING:** Negligence of these instructions can lead to accidents.

## 1. BASIC PRECAUTIONS FOR SAFETY

### ■ Pay attention to ventilation.

- Exhaust fumes are dangerous if breathed in. When starting the engine in an enclosed area, provide good ventilation with windows and doors opened.



### ■ Do not stand close to the exhaust gas pipe opening.

- Exhaust fumes are noxious if breathed in.

## 1.4 After Starting the Engine

### ■ Secure safety around the machine.

- Ensure that the area around the machine is clear of personnel and obstructions. Pay particular attention to dead spaces. Before starting, sound the horn.



### ■ Warm up the Engine

- Do not put your machine into motion immediately after the engine has started, let it idle for several minutes until it is at operating temperature.

### ■ Have a trial run.

- Make a test run in a safe place to check that there are no abnormal signs. If found to be abnormal, rectify the fault before traveling again.
- Listen for unusual sounds, and check for abnormal temperature rise. If abnormal, park the machine in a safe location and find the source of trouble before operating.

## 1.5 During Operation

### ■ No other person but the operator

- This machine is a one-man roller. Do not allow anyone to get on. Only the operator is allowed on this machine while it is running or in operation. Radios are not permitted.

### ■ Before mounting, be sure areas around the machine are safe.

- Before getting on the machine, make certain that there are no obstacles around the machine and no workers under it. If some workers are present or close to the machine, tell them that the machine is about to move, warning them to stay away from it.

**⚠ WARNING:** Negligence of these instructions can lead to accidents.

## 1. BASIC PRECAUTIONS FOR SAFETY

■ **Do not try to get on or off a moving machine.**

- Get on or off the machine after making sure it has come to a complete stop.

■ **To go uphill or downhill, run at low speeds. Do not attempt to shift speeds while traveling on a grade.**

- Shifting speeds on a slope can cause unexpected running down the slope.
- Going down hill at speeds other than low range can cause the machine to run down violently.

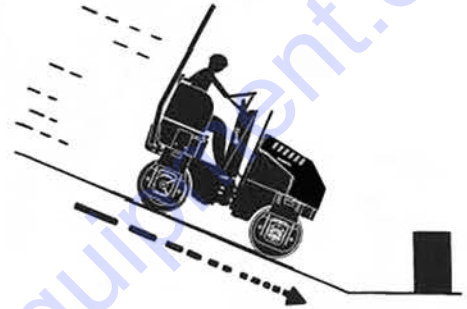

■ **Refrain from inattentive driving.**

- Inattentive driving or driving relying on guess work can cause an accident. Use extreme care for workers present in the path of the roller or around it. In case of danger, stop and sound the horn, and proceed when the area is clear of personnel or obstructions.

■ **When changing the direction of travel, secure the safety on the path in the travel direction.**

■ **Keep everyone away from the pinch points.**

- When making turns, do not allow anyone to come close to the pinch point.



■ **At night, carefully drive the machine.**

- Nighttime driving tends to frustrate the sense of distance. Carefully drive the machine at a speed suited to illumination. Keep the headlamps and flood lamps lighted. If necessary, provide extra lighting in the work area.

■ **Repair as soon as possible if found to be defective.**

- If the machine is found to be faulty, stop the machine and repair. Do not operate the machine until the problem is corrected. When any warning lamp indicates faulty operation, inspect the machine after moving it to the nearest safe location.

**⚠ WARNING:** Negligence of these instructions can lead to accidents.

### 1. BASIC PRECAUTIONS FOR SAFETY

- Do not operate the machine except from the operator's seat. Do not drive in a standing posture.
- While making turns, do not run at abnormally high speed and do not turn the steering wheel abruptly and sharply.
- For the traveling on structures such as a bridge, make certain that they can support your machine. Before traveling on the structure, you must know the load capacity of the structure and the load weight of the machine you are operating to insure safe travel across the structure.
- Do not make turns on a slope and do not travel across sidehill. If necessary to do so, go down straight along the slope to the flat ground, move sideways and go up straight to the destination.

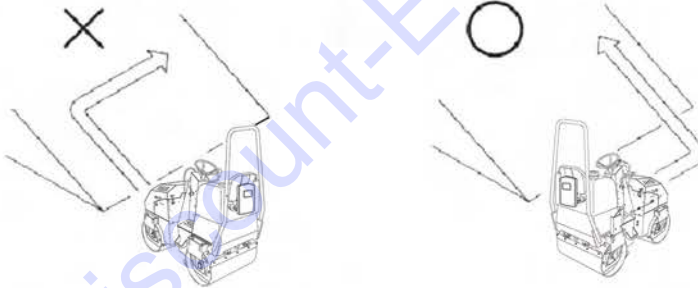

#### ■ When parking.

- Select level and hard ground. If necessary to park on a slope, block the front of the drums on the downside of the slope.
- When required to park on the public road, provide necessary markings such as flag, barriers and illumination. However, be sure they do not obstruct traffic.
- When getting off the machine, stop the engine and remove the key from the ignition switch.

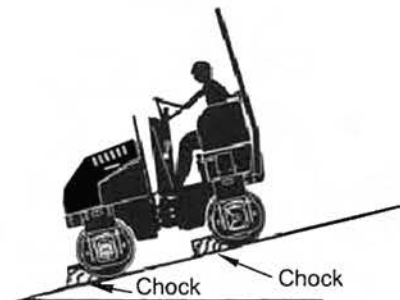

### 1.6 Loading and Unloading

- Loading and unloading can accompany any danger. Use extreme care.
- Select level and hard ground leaving a sufficient distance from the shoulder.
- Use sturdy ramps with proper width, length and thickness which allow safe loading and unloading. If they deflect considerably under load, apply wooden blocks to reinforce the ramps.

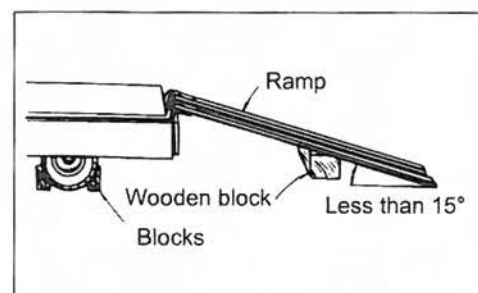

**⚠ WARNING:** Negligence of these instructions can lead to accidents.

## 1. BASIC PRECAUTIONS FOR SAFETY

- To prevent your machine from crosswise slippage, keep the ramps free from oil, mud, debris, etc. The drum must also be free from extraneous matter that can cause slippage.
- Do not steer your machine on the ramps. If the machine is facing in the wrong direction, allow it to dismount from the ramps, correct the direction and try again.
- Do not use kinked, twisted or damaged wireropes for crane or winch operation. Use ones with ample strength.
- When loading is complete, fix the machine with wooden blocks placed under the drums and chains fastened to the machine.

### 1.7 Transportation

- Follow required regulations.
- Select a transporting route according to the overall width, overall height and gross weight of the trailer with the roller loaded.

### 1.8 Handling the Battery

■ When handling the battery:

- Battery electrolyte contains sulphuric acid. It will destroy clothing and skin. If it touches your clothing or skin, flush with large quantities of water.
- In case of eye contact, flush with clean water and seek medical help.
- If swallowed, drink large amount of water, milk, beaten egg or vegetable oil, and get medical help.
- Wear safety goggles when handling the battery. Wear safety goggles, full face shield, rubber gloves and rubber apron when adding fluids to the battery.
- The battery generates flammable gases that can cause an explosion. Do not smoke close to the battery. Keep the battery away from flames, sparks and ignition sources.

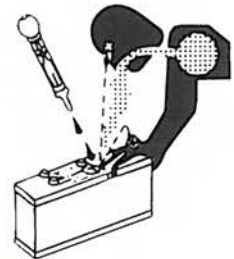



**⚠ WARNING:** Negligence of these instructions can lead to accidents.

## 1. BASIC PRECAUTIONS FOR SAFETY

- Inspect or handle the battery with the engine shut down and the starter key in the OFF position.
- Keep metallic items such as tools away from the battery terminals.
- Loose terminals can cause sparks leading to an explosion. Secure the terminals tightly.

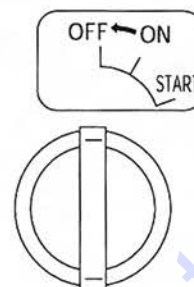

### ■ Jump-starting the engine.

- Wear safety goggles when jump-starting the machine.
- When starting from another machine, do not allow the two machines to make contact with each other.
- When connecting the battery cables, start with the positive terminal. For disconnection, start with the negative one.
- Do not allow a tool to bridge between the positive terminal and machine body. This can generate dangerous sparks.
- Do not connect the booster cable to wrong terminal. NEVER connect the positive terminal to the negative.
- Final connection to the engine block of the disabled machine can cause sparks. The connecting point should be as far as possible from the battery.

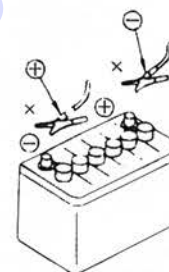

## 1.9 Towing

- To tow the machine, use wire ropes with ample strength.
- Do not perform towing on a slope.
- Do not use towing ropes twisted, kinked or damaged.
- Do not stride towing cables.
- Keep everyone away from the space between the machine and the towing vehicle when connecting the two.
- Align the connecting portions of the machine and towing vehicle straight when coupling the machine.

**⚠ WARNING:** Negligence of these instructions can lead to accidents.

**1. BASIC PRECAUTIONS FOR SAFETY**

### 1.10 Before Servicing

■ **Attach warning tags when servicing the machine.**

- Serious accidents can occur if the machine is unexpectedly started or controls carelessly touched by an unauthorized person.
- Attach a warning tag at a clearly visible location in the operator's station and insure the key has been removed from the ignition switch.



■ **Use proper tools.**

- It is very dangerous to use damaged or deteriorated tools or to use tools for other purposes than intended. Use correct tools for their intended use only.



■ **Change safety-related parts at regular intervals.**

- Replace fuel hose and high pressure hydraulic hoses regularly to prevent fire. Replace high pressure hoses of the power steering system every two years.
  - ☆ Change these parts at regular intervals even if found to be normal. They will deteriorate as time goes on.
  - ☆ Change any hose found to be abnormal even if it is within its recommended service interval.

■ **Inspect or service your machine with the engine stopped.**

- One of them should sit on the operator's seat getting ready for shutting down the engine. He must take care not to touch any of controls carelessly. Maintenance personnel must exercise extreme caution not to make contact with moving parts.

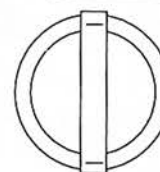
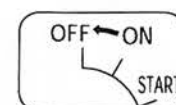

**⚠ WARNING:** Negligence of these instructions can lead to accidents.

## 1. BASIC PRECAUTIONS FOR SAFETY

### ■ Supplying fuel and oils

- Spilled fuel or oil will be slippery. Wipe up immediately. Keep the filler caps tight. Do not use fuel for flushing oil. Handle fuel and oil in a well ventilated area.

### ■ Illumination

- For inspecting the level of the fuel, oil, and battery electrolyte, use burn-proof illuminations. Failure to use this type of illumination can result in an explosion.



## 1.11 During servicing

### ■ Keep unauthorized persons away

- During service, do not allow persons not concerned to enter the work area, particularly when grinding or welding operation is performed or heavy hammers are being used.



### ■ Keep your machine clean

- Spilled oil, grease or scattered debris are dangerous. Always keep your machine clean. Moisture that penetrates into the electrical system can cause malfunctions. Do not use water to clean sensors, connectors and the operator's station.

### ■ When repairing the electrical system

- For repairing the electrical system or for conducting welding, disconnect the negative cable from the battery to shut off the electricity.



### ■ Carefully handle high pressure hoses.

- Do not try to bend or hit hoses against a hard object. Do not use hoses or pipes that are bent or damaged. They will burst.
- Replace damaged fuel hose and hydraulic hoses. An oil or hydraulic fluid spill can cause a fire.

**⚠ WARNING:** Negligence of these instructions can lead to accidents.

## 1. BASIC PRECAUTIONS FOR SAFETY

### ■ Be careful of high pressure hydraulic fluid.

- Bear in mind that the working equipment hydraulic systems are under internal pressure. Do not perform adding, draining, inspection or servicing of the hydraulic systems until the internal pressure has been relieved. Hydraulic fluid leaking through a fine hole at high pressure can penetrate your skin and eyes. Inspect leakage by holding a hard board close to suspected leaks wearing goggles. If affected by high pressure oil, get medical help immediately.



### ■ Be careful of hot parts

- After the machine has been operated for some time, engine oil and hydraulic fluid will become hot.
- Removing the oil can burn you. Perform this work in accordance with correct procedures after the systems have cooled down.



### ■ Use care when inspecting or servicing fan or belts in motion

- Secure loose clothing and keep articles away that could get caught in moving parts.
- Do not let your body or tools make contact with the fan blades or belts. They can be cut seriously.



### ■ Used oil disposal

- Do not throw used oil into a drain or waterway. Drain the oil from the machine into a proper container. Do not drain directly on the ground.
- Obey all local, state and federal environment regulations for the proper disposal of oil, fuel, battery electrolyte or any other fluids.

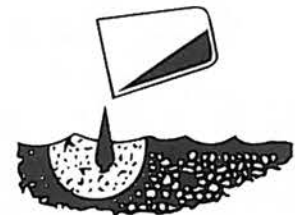

**⚠ WARNING:** Negligence of these instructions can lead to accidents.

**1. BASIC PRECAUTIONS FOR SAFETY**

**1.12 Safety Decals**

Keep all decals clean. If lost, replace with new one. There are decals other than those shown below: Treat them in the same manner as the one shown here.

① 3998-16491-1

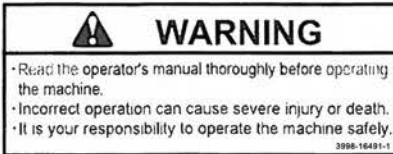

⑤ 3998-16500-0



② 3998-16499-0 (2 locations)



⑥ 3998-16502-0

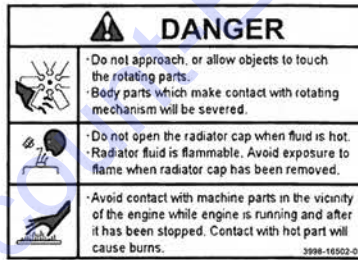

③ 3998-16501-0



⑦ 3998-36002-0 (2 locations)



④ 3998-16505-0

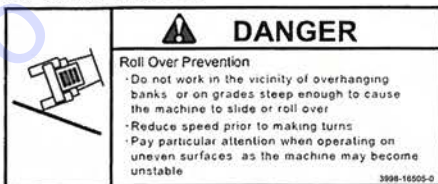



## 2. OPERATION

### 2. OPERATION

#### 2.1 Instruments and Controls

##### 2.1.1 Operator's station

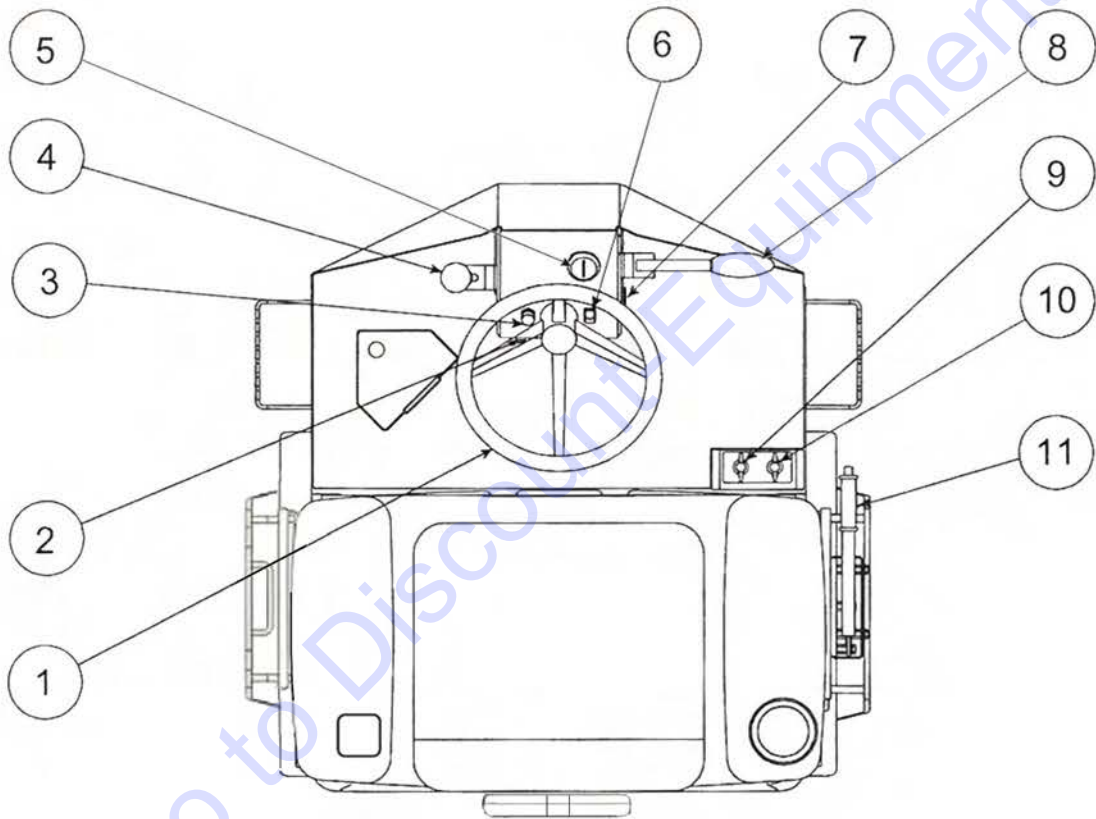

- ① Steering wheel
- ② Choke knob
- ③ Horn switch button
- ④ Throttle lever
- ⑤ Starter switch
- ⑥ Engine oil pressure lamp

- ⑦ Hour meter
- ⑧ Forward-reverse lever (F-R lever)  
with vibrator switch
- ⑨ Water control knob (Rear)
- ⑩ Water control knob (Front)
- ⑪ Parking brake lever

### 2.1.2 Gauges and warning lamps

For safe execution of your job, fully understand the role and function of the systems involved.

#### Hour meter

Indicates total operating hours. The service interval recommendation in this manual should be based upon the hour meter readings.

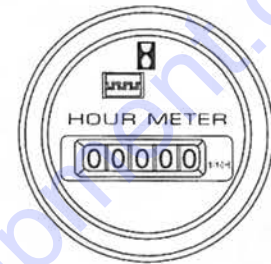

#### Engine oil pressure lamp

Goes on when engine lubricating oil pressure is lowered below specified value.

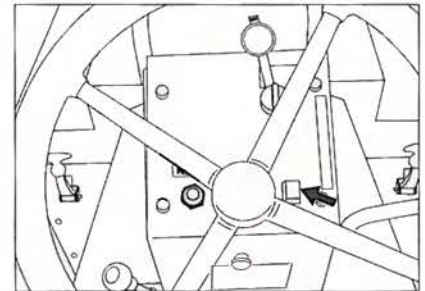

#### ★ Warning lamp [Engine oil pressure lamp]

Go on when the starter switch is turned to the ON position and go off when the engine has started. If not, corresponding bulb burnt out.

If any of them lights up while engine is running, this indicates a faulty condition. Stop the engine and trace the source of trouble.



## 2. OPERATION

### 2.1.3 Switches

#### Starter switch

Starts and stops the engine.

**OFF** : The key can be removed in this position. All the electric systems are switched off. To shut down the engine, move the key to this position.

**ON** : The charging circuit and lamp circuit are charged with electricity. Let the key stay in this position after the engine has started.

**START**: The engine is cranked and gets started. The moment the engine has started, release the key. It will automatically return to the ON position.

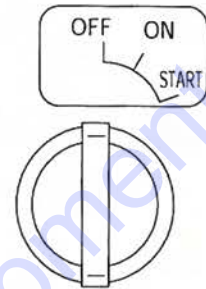

#### IMPORTANT

**When the engine is cold, turn the key to the START position to start the engine, pulling the choke knobe. The choke knobe will return to the original position, if its hold is released.**

#### Horn switch button

Pressing the button at the side of the steering wheel makes the horn sound.

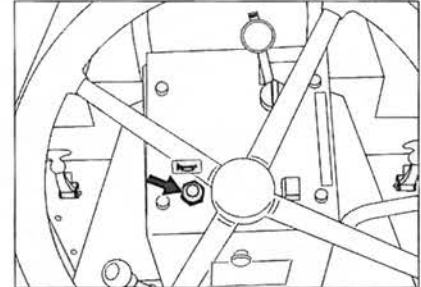

Vibrator switch

On-off control of the vibrator is also made by the pushbuttons provided on the F-R lever. Press to work the vibrator. Press again to shut off vibration.



**IMPORTANT**

- Do not operate the vibrator on a hard area such as cement concrete pavement surface or the ground covered by thick steel sheets.
- Keep the vibrator stopped when the machine is at rest.
- Shut off the vibrator immediately when the machine has been caught in the mud during vibratory operation.

## 2. OPERATION

### 2.1.4 Operating levers and knob

#### Forward-reverse lever (F-R lever)

Moving the F-R lever forward or backward makes the machine travel forward or backward respectively. The neutral position brings the machine to a stop. The vehicle speed increases or decreases in proportion to the lever displacement.

The vibrator ON-OFF control is easily made by the F-R lever top vibrator switch (See page 21).

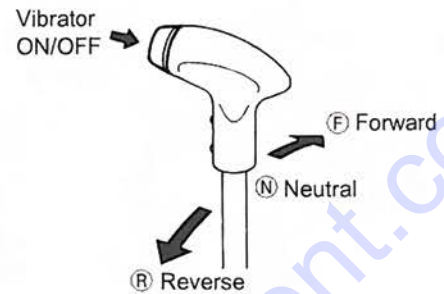

#### ⚠ CAUTION

- To start the engine again, set the F-R lever to neutral and get starting after securing safety.

#### Throttle lever

Shifts the engine RPM. The engine RPM increases when moved toward the operator.

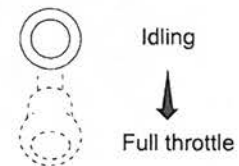

#### Parking brake lever

To apply the parking brake, pull the lever up. To release the brake, press the lever-top button and push the lever down.

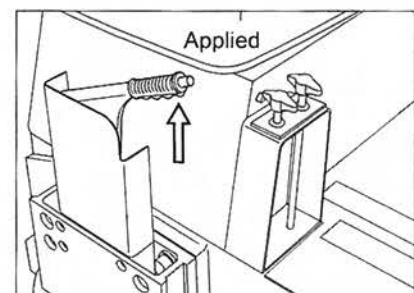

#### ⚠ WARNING

When dismantling from the machine, pull up the lever without fail to apply the brake.

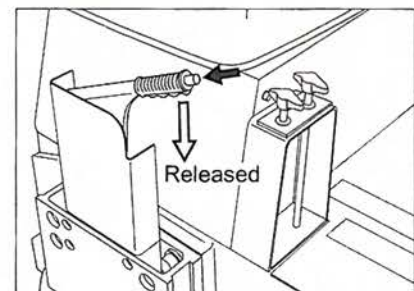

### Unloader lever

The unloader lever disengages the drive, playing a role like a clutch. Use this lever for towing the machine when the engine is disabled or when troubles have developed in the hydraulic drive.

For towing:

Turn the unloader lever counter-clockwise (Unload).

For normal traveling:

Turn the unloader lever clockwise (Onload).

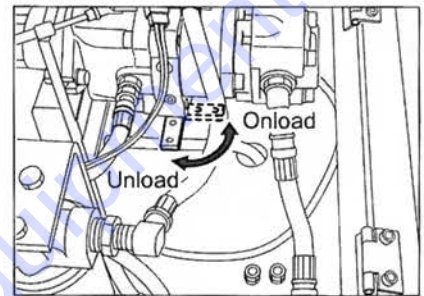

### ⚠ WARNING

- On a slope, chock the wheels and use extreme care when handling the unloader lever and towing the machine.
- Be sure to apply the parking brake when operating the unloader lever.

**NOTE:** For normal travel, be sure to hold the lever in the ONLOAD position.

### Choke knob

When the engine is cold, pull the choke knob.

While pulling the choke knob, choke closes.

If its hold is released, the choke knob will return and choke will open.

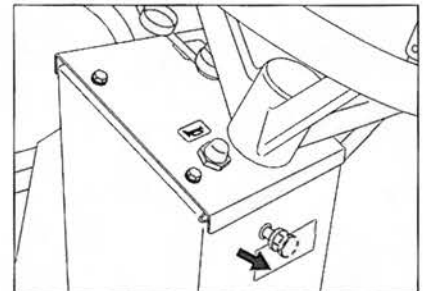

### Water control knob (Front)

### Water control knob (Rear)

Turn On/Off the water control knob for each of front and rear rolls.

Turn it clockwise to start sprinkling of water and counterclockwise to stop it.

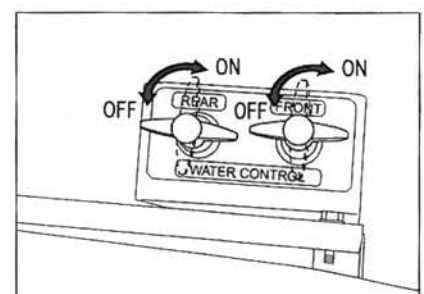

## 2. OPERATION

### 2.1.5 Fuse

#### **⚠ WARNING**

When changing a fuse, cut the power supply by turning the starter switch to the OFF position.

Fuses protect electrical components and wiring from burning. Be sure to use fuses of correct capacity consulting the electric wiring diagram (see page 53).

## 2.2 Handling and Adjustments

### 2.2.1 Scraper adjustment and replacement

#### 1) Clearance adjustment of blades (a).

- ① Loosen fixing bolts (b) at 2 locations.
- ② Loosen nuts (c). Slide blades (a) until they make contact with the drum. Retighten nuts (c).
- ③ For fine adjustment, turn set bolt (b).

#### 2) Replacement of scraper blades

- ① Remove bolts (d).
- ② Replace blades (a) with new ones.
- ③ Refit and retighten bolts (d).

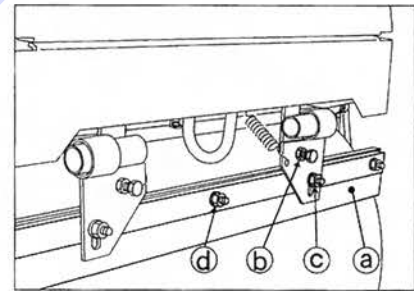

## 2.3 Operation

### ⚠ WARNING

- This machine is a one-man roller.
- Operate the machine from the operator's seat.

### 2.3.1 Before-starting inspection

- 1) Check that the steering lock pin is in the carrying position.

### ⚠ WARNING

Make sure that the steering lock pin is connected in the carrying position before putting the machine in motion. Steering is impossible if the pin is in the steering lock position.

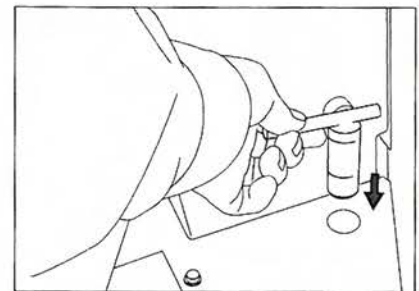
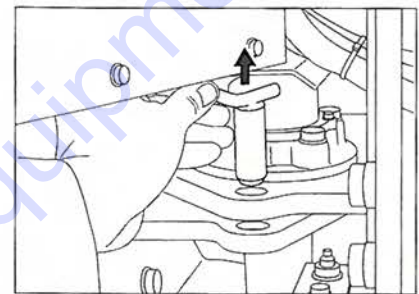

**NOTE:** Return the lock pin to its storage position on the floor board of the operator's seat.

- 2) Check that the F-R lever is in the neutral position (N).

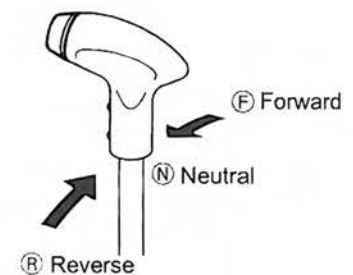

**NOTE:** The engine does not start if the F-R lever is not in the neutral position.

**TO PURCHASE THIS PRODUCT PLEASE CONTACT US**



**Equipment Financing and  
Extended Warranties Available**



**Discount-Equipment.com is your online resource for  
commercial and industrial quality parts and equipment sales.**

**561-964-4949**

**visit us on line @ [www.discount-equipment.com](http://www.discount-equipment.com)**

Select an option below to find your Equipment

**Search by Manufacturer**

**Search by Product Type**

**Request a Quote**

We sell worldwide for the brands: Genie, Terex, JLG, MultiQuip, Mikasa, Essick, Whiteman, Mayco, Toro Stone, Diamond Products, Generac Magnum, Airman, Haulotte, Barreto, Power Blanket, Nifty Lift, Atlas Copco, Chicago Pneumatic, Allmand, Miller Curber, Skyjack, Lull, Skytrak, Tsurumi, Husquvarna Target, Stow, Wacker, Sakai, Mi-T-M, Sullair, Basic, Dynapac, MBW, Weber, Bartell, Bennar Newman, Haulotte, Ditch Runner, Menegotti, Morrison, Contec, Buddy, Crown, Edco, Wyco, Bomag, Laymor, EZ Trench, Bil-Jax, F.S. Curtis, Gehl Pavers, Heli, Honda, ICS/PowerGrit, IHI, Partner, Imer, Clipper, MMD, Koshin, Rice, CH&E, General Equipment, Amida, Coleman, NAC, Gradall, Square Shooter, Kent, Stanley, Tamco, Toku, Hatz, Kohler, Robin, Wisconsin, Northrock, Oztec, Toker TK, Rol-Air, APT, Wylie, Ingersoll Rand / Doosan, Innovatech, Con X, Ammann, Mecalac, Makinex, Smith Surface Prep, Small Line, Wanco, Yanmar

## 2. OPERATION

### 2.3.2 Starting the engine

#### **⚠ WARNING**

Check that the F-R lever is in the neutral position, and sound the horn when starting the engine after making certain that there are no one and no objects close to the machine.

- 1) Set the throttle lever in a position slightly higher than IDLING.

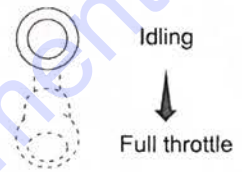

- 2) Turn the starter switch to the ON position and check that the engine oil pressure lamp are on.

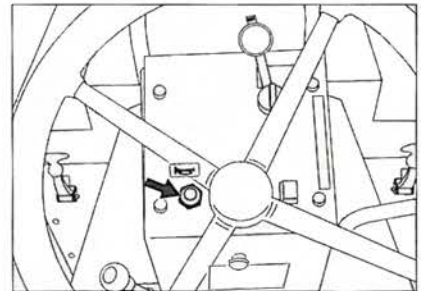

- 3) In cold weather, start the engine while pulling the choke knob.

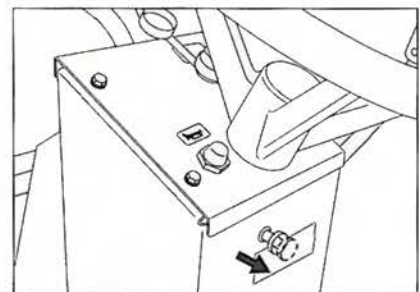



- 4) Turning the key to the START position makes the engine start. Release the key the moment the engine has started. The key will automatically return to the ON position.

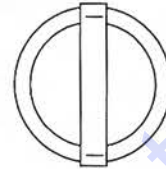
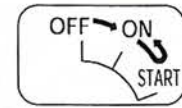

**⚠ CAUTION**

- Do not allow the starter key to stay in the START position for more than 5 seconds.
- If the engine does not start, allow an interval of 15 seconds before trying again.
- Check that the warning lamps on the engine oil go off immediately after the engine is started. If any of these warning lamps becomes bright while the engine is running, shut down the machine, determine the cause and rectify the fault.

**2.3.3 After starting the engine**

Try not to move to operation immediately after starting but observe the following:

**IMPORTANT**

**Avoid increasing the engine speed abruptly before warming-up run is completed.**

- ① Run the engine at idle for about 5 minutes to warm it up. Warming-up run allows the lubricating oil to reach the vital parts of the engine and hydraulic system, while gradually bringing up the engine oil and hydraulic oil to the working temperature.
- ② After the warm-up operation, check that:
  - Engine oil pressure lamp .....Has gone off.
- ③ Check for the color of exhaust gas, listen for unusual sounds and vibration. If abnormal, determine the cause and correct the problem.

## 2. OPERATION

### 2.3.4 Traveling

#### ⚠ CAUTION

While travelling, do not turn the starter switch OFF.

#### ⚠ WARNING

When starting, operate the horn after securing the safety around the machine.  
Clear away obstacles on the road.

- 1) Speed up the engine by pulling the throttle lever towards you.

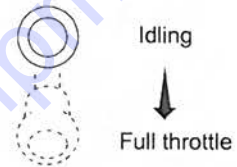

- 2) Release the parking brake.

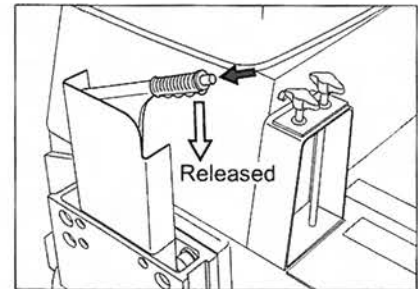

- 3) Move the F-R lever in the direction to travel, and the machine will begin traveling.

#### ⚠ CAUTION

Avoid abrupt operation of the F-R lever.

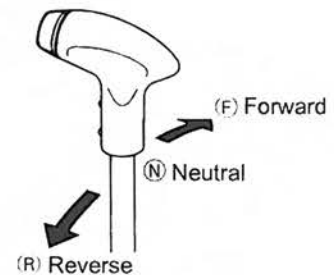

**NOTE:** The travel speed can be controlled by the throttle lever and F-R lever.

#### ⚠ WARNING

Pay extreme attention to the area behind the machine when backing, since the space just behind it tends to be a blind spot.

### 2.3.5 Stopping/Parking

#### ⚠ WARNING

- Avoid abrupt braking. Try to leave enough time for braking.
- Avoid parking on a grade.
- If necessary to park on a grade, block the wheel to prevent unexpected moving down the grade.

1) Bring the F-R lever to the neutral position (N), and the machine will come to a halt.

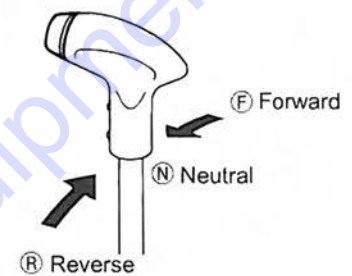

2) Pulling the parking brake lever for braking.

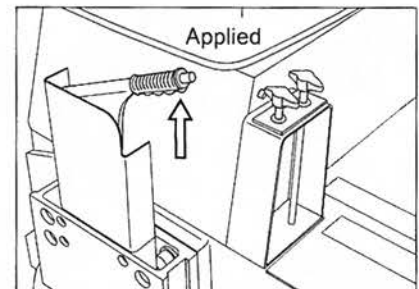

### 2.3.6 Stopping the Engine

1) Gradually cool down the engine at low idling for about 5 minutes with the throttle lever in the idling position.

#### IMPORTANT

- Do not bring a hot engine to a sudden stop except for an emergency. This will shorten the life of its component parts.
- Do not also allow an overheated engine to come to a sudden stop, but run it at middle idling speed for gradual cooling down.

## 2. OPERATION

- 2) Turn the starter key to the OFF position to stop the engine.

### ⚠ CAUTION

Do not turn the starter switch OFF while the machine is in motion.

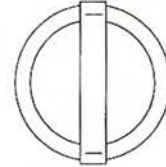
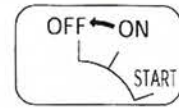

- 3) Pull off the starter switch key.

### ⚠ WARNING

- When dismounting from the machine, apply the brake by pull the parking lever. If necessary to park on a grade, block the wheels to prevent unexpected moving down the grade. Never fail to remove the starter key.
- Remove the starter switch key.

### 2.3.7 Check after stopping the engine

- 1) Perform the walk-around checks for oil and water leakage, abnormal signs around the drums.
- 2) Fill the fuel tank.
- 3) Remove waste paper if any from the engine compartment, as this will pose a possible fire hazard.
- 4) Scrape mud or other materials from and around the drums.

### 2.4 Vibratory Operation

- 1) Run the engine at full throttle by pulling the throttle lever toward you.

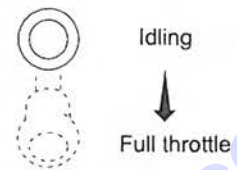

- 2) Press to work the vibrator on the switch of F-R lever. Press again to shut off vibration.



- 3) Proper travel speed for vibratory compaction is 2 ~ 5 km/h, however, select speeds depending upon job requirements.

#### ⚠ CAUTION

- Keep the vibrator shut off when the machine is not rolling.
- Stop vibration if the machine has encountered a running difficulty, for example, when it gets stuck in the mud.

## 2. OPERATION

### 2.5 Sprinkler

- 1) Before sprinkling, check for the water level in the sprinkler tank by taking off the filler cap. Add water as necessary.

#### IMPORTANT

Use clean water wherever practicable.

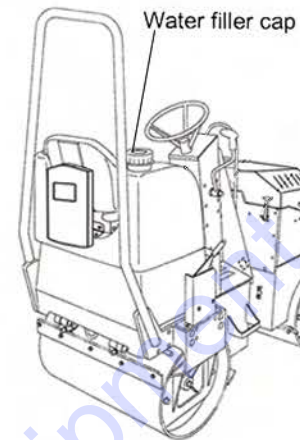

Sprinkling on the front drum only or rear drum only.

Before sprinkling, close the sprinkler knob located at the right lower part under the operator's seat.

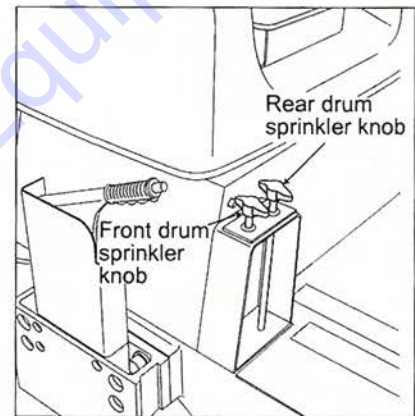

- 2) Turn the knob clockwise to start sprinkling of water and counterclockwise to stop it.

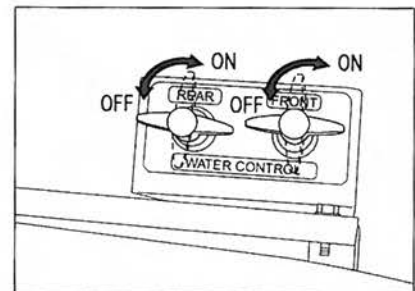

To drain water:

- ① Turn sprinkler tank drain cap **a** counter-clockwise and completely drain the tank.
- ② After completion of draining, leave all cocks open.

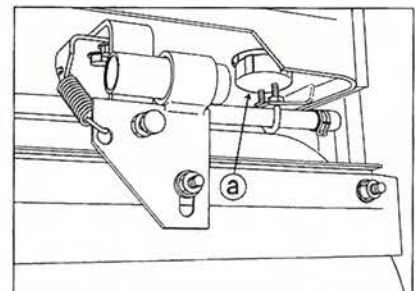

## 2.6 Precautions for Work

### 2.6.1 Compaction operation

#### ■ Do not operate the vibrator on hard location

- Do not work the vibrator on a hard surface such as concrete pavement, as this can cause the machine to jump and give abnormal shock load. Damage to shock isolators will result.

#### ■ Change the direction of travel gently.

- When changing the direction of travel during asphalt mix compaction, slowly shift the F-R lever.

### 2.6.2 When going downhill

#### ■ Use the F-R lever.

- Run slowly by the operation of the F-R lever even if the travel distance is short.

#### ■ Use the engine brake

- Go downhill by applying the engine brake along with the F-R lever operation.

### 2.6.3 On a slope

#### ■ Working on a sidehill

- Work in an uphill/downhill direction, and avoid working on sidehill with the machine inclining sideways.

## 2.7 Applicable Jobs

The machines do a variety of jobs as listed below:.

They most effectively handle works or materials marked ★.

### Work

#### ★Asphalt road paving

- Dust removal treatment for road
- Road improvement
- Embankment construction
- Dam construction

#### ★Construction of forestry and farm roads

- Foundation building
- Construction of sidewalk, shoulder and gutter foundation

## 2. OPERATION

### Material to be compacted

- ★ Asphalt pavement
  - Crusher run
  - Cement concrete
- ★ Sands
  - Soils
  - Slag
  - Soft rock

### Layers to be compacted

- ★ Surface course, Binder course
- ★ Base course
  - Subgrade
  - Embankment
  - Shoulder
- ★ Sidewalk

## 2.8 After Operation

Check for the fuel level.

Follow the procedures below to prevent the machine from falling into an unworkable condition the following morning caused by muds and other extraneous matter on the drum, or frozen drums:

- 1) Remove muds and water from the machine. Muds can get into the seals together with water drops on the hydraulic cylinder piston rod. Damaged seals will result.
- 2) Park the machine on a hard and dry surface. If such a place is not available, cover the ground with hard plates.
- 3) Low temperature will cause a significant reduction of battery efficiency. Cover batteries or take them off from the machine and store in a warm place for the following day's operation.
- 4) To avoid freezing, fully drain the sprinkler tank, pipes and filter in cold weather.  
(See page 32).

### IMPORTANT

- Drain water completely from the sprinkler system, as remaining water can cause damage to the system.
- Do not pressure clean around the instrument panel or the back side of the dashboard.



## 2.9 Loading and Unloading

### ⚠ WARNING

- Use sturdy ramps with proper width, length and thickness which allow safe loading and unloading.
- If the ramps deflect considerably under load, apply wooden blocks to reinforce them.
- Loading should be conducted on a level and hard ground. Leave a sufficient distance between the machine and the shoulder.
- To prevent slippage on the ramps, keep the drums free from mud, oils, etc. The ramps must also be free of grease, oil and ice.
- Do not steer the machine on the ramps. If the machine is facing in the wrong direction, allow it to dismount from the ramps and correct the direction.

For loading and unloading, use ramps or a proper loading stand.

### 2.9.1 Use of a trailer equipped with a winch

### ⚠ WARNING

Placing the unloader in UNLOAD position disrupts the power for traction. Do not enter the areas ahead of and behind the machine. It is very dangerous.

- 1) Engage the trailer brake and chock its wheels. Fix the ramps so that the machine and trailer are completely aligned.
  - ☆ The angle between the ramps and ground must be less than 15 degrees.
  - ☆ Leave a proper space between the ramps according to the width of the roller drum.
- 2) Decide the correct direction of run and make the machine run forward to the ramps.

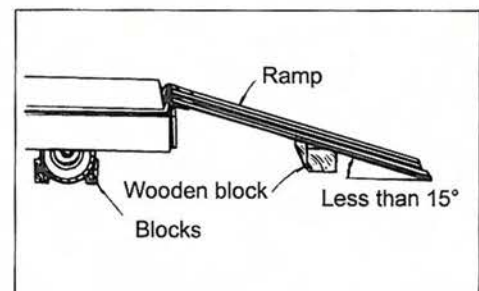

## 2. OPERATION

- 3) Draw the wire rope from the trailer winch and put its hook on the hooking point ① or ②.
- 4) Place the unloader lever located inside the engine compartment to the UNLOAD position (See "Unloader lever" on page 23).
- 5) With the engine running at idle, perform loading by means of the trailer winch.
- 6) When the loading is completed, set the unloader lever back in the ONLOAD position.
- 7) Locate the machine correctly on the trailer.

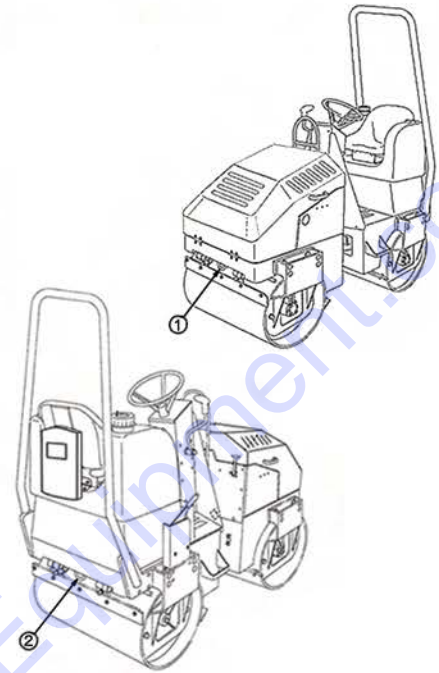

### 2.9.2 Self-propelling

- 1) Engage the trailer brake and chock its wheels. Fix the ramps so that the machine and trailer are completely aligned.
  - ☆ The angle between the ramps and ground must be less than 15 degrees.
  - ☆ Leave a proper space between the ramps according to the width of the roller drum.

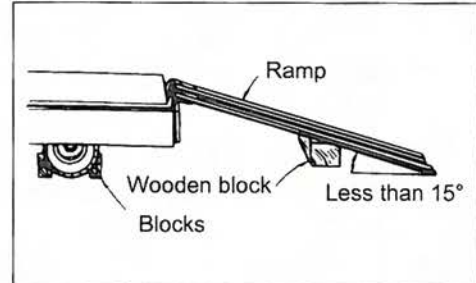

- 2) Decide the correct direction of run and conduct loading or unloading at low speed.

For loading, run forward at low speed.  
For unloading, run backward at low speed.

- 3) Locate the machine correctly on the trailer.

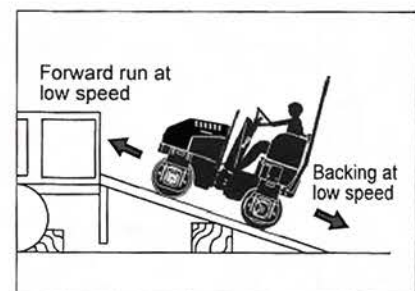

### 2.9.3 Use of a mobile crane.

#### ⚠ WARNING

- When lifting, use sturdy wire ropes.
- Before lifting, lock articulation by means of lock far located by the center pin.
- Keep your body out of the frame faces to prevent a pinch.

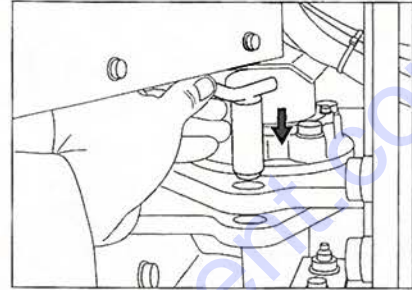

- 1) Before starting to work, the mobile crane operator must check the crane for normal working condition in accordance with the prescribed check list.
- 2) The slinging worker must check wire ropes to see if they are in normal condition to use.
- 3) When loading and unloading, set the outrigger on both sides of the crane securely, and use thick wooden or steel sheets to provide a firm footing.
- 4) The trailer driver must apply the parking brake positively and chock the wheels to secure machine stability.
- 5) The mobil crane operator and slinging worker should work together strictly observing hand signals.
- 6) Put the wire rope hook on the hooking point of the roller, carefully perform loading or unloading securing the ballane of the roller.
- 7) Slowly conduct loading and unloading being careful not to allow the roller to make contact with the wire ropes on other lifting gears.
- 8) Locate the machine correctly on the trailer.

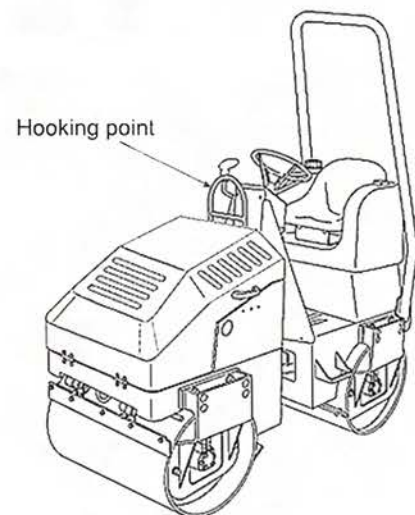

### 2.10 After Loading the Machine

When the machine has been located properly on the trailer, tie it down as follows:

- 1) Pull the parking brake lever to apply the parking brake. Place wooden blocks under the drums to prevent movement.
- 2) Fix the machine with ropes tied at the front and rear towing hook holes. Particularly, pay attention to sidewise skidding.

## 2. OPERATION

### 2.11 Transportation

#### **⚠ WARNING**

To decide the transporting route, check the width of the road, height and weight (including the roller) of the trailer. Obey relevant regulations.

For transportation, obey traffic regulations.

### 2.12 Operation in Cold Weather

In cold weather, take the following measures to prevent troubles such as starting difficulty and coolant freeze-up.

#### 2.12.1 Fuel oil and grease

Use fuel and oil with low viscosity. See "Rating" on page 52.

#### 2.12.2 Battery

#### **⚠ WARNING**

- Batteries generate explosive gases. Do not use an open flame close to batteries.
- The battery electrolyte is corrosive. Keep the electrolyte away from your eyes and skin. If you are affected by the electrolyte, flush with large quantities of water and get medical help.

When the temperature decreases, the battery capacity will lower, possibly freezing the electrolyte.

Keep the battery in a satisfactory condition at all times, and pay attention to heat insulation for satisfactory start-up on the next morning.

The hydrometer atop the battery permits confirmation of the condition of the battery.

Green.....Satisfactory

Black.....Charging is necessary

Semitransparent...Replacement is necessary

### 2.13 When the Cold Season is Over

When winter is over and the warm season has come, proceed as follows:

- 1) Change oil and fuel with those of specified viscosity rating in accordance with manufacture's recommendation.
- 2) If AF-PT antifreeze is in use, drain the coolant completely, wash clean inside the cooling system, and then fill with clean water (city water).

### 2.14 For a Long Storage Period

For leaving the machine unused for longer than one month, proceed as follows:

- 1) Store the machine in a closed area after cleaning.
- 2) Conduct oiling, greasing and changing of oil.
- 3) Grease lubricate the exposed portion of hydraulic cylinder piston rods.
- 4) Cover the battery after disconnecting the negative cable or take off the battery from the machine and store in a safe place.
- 5) If the temperature is expected to go down below 0°C, add antifreeze to the coolant.
- 6) Completely drain the sprinkler water.
- 7) Place the F-R lever in the neutral position (N), turn the vibrator off and apply the parking brake.
- 8) Chock the machine.
- 9) Remove the starter switch key.

### 2.15 During the Storage Period

**⚠ WARNING**

If necessary to operate the machine for anti-corrosive purpose in closed area, ensure good ventilation keeping windows and doors open to prevent gas poisoning.



- During storage, operate the machine at least once a month to prevent the oil films on the lubricated parts from deteriorating and to charge the batteries.

## 2. OPERATION

### 2.16 When the Battery Has Discharged

#### ⚠ WARNING

- To check and handle the batteries, keep the engine stopped with the starter switch in the OFF position.
- The batteries give off explosive gases. Do not smoke close to the batteries. Keep flames and sparks away from the batteries.
- The electrolyte is very corrosive and will harm your clothing or skin. If the electrolyte has come into contact with your clothing or skin, flush with sufficient amount of water. In case the electrolyte has gotten into your eyes, flush with water and get medical help.
- To disconnect the battery cables, start with the negative terminal (earth). When connecting, start with the positive terminal. Do not allow a metallic item to bridge between the positive terminal and machine body. This can generate sparks, causing an explosion.
- Loose battery terminals can cause sparks. An explosion will result. When connecting the terminals, make certain that they are tight.

Disconnect with negative cable first

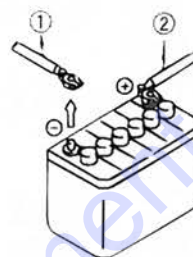

Connect with positive cable first

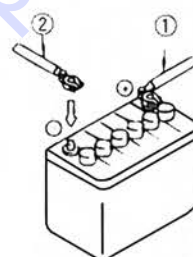

#### 2.16.1 Connection and disconnection of booster cables

When jump-starting the engine, connect the booster cables as follows:

##### ■ Connection of booster cables

- 1) Connect one end of the positive booster cable (A) to the positive (+) terminal of the battery on the machine.
- 2) Connect the other end of the positive booster cable to the positive (+) terminal of the booster supply.
- 3) Connect the negative booster cable (B) to the negative (-) terminal of the booster supply.
- 4) Connect the other end of the negative booster cable to a good earth of the engine block of the machine.

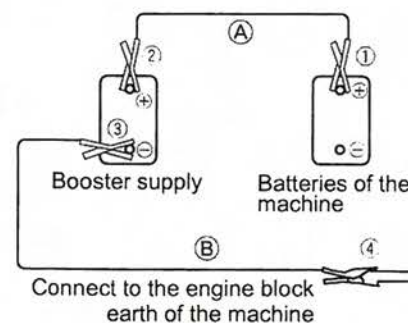

### ■ Disconnection of booster cables

- 1) Disconnect the negative booster cable (B) from the engine block earth.
- 2) Disconnect the negative booster cable (B) from the booster supply.
- 3) Disconnect the positive booster cable (A) from the booster supply.
- 4) Disconnect the positive booster cable (A) from the machine.

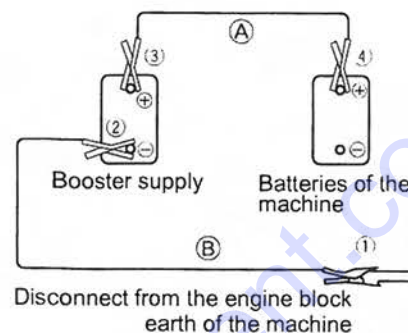

### ⚠ WARNING

- Do not allow the positive (+) terminal to make contact with the negative (-) terminal when connecting the booster cables.
- Wear safety goggles when jump-starting the engine.
- Do not allow the machine to make careless contact with the booster supply.
- Do not make wrong connections. Connect the negative (-) cable to the engine block earth far away from the battery, as sparks may occur when connecting.

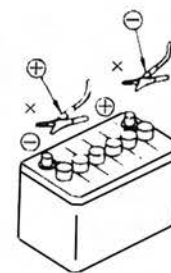

### ⚠ CAUTION

- Use booster cables and end clips of proper size suited to the battery capacity.
- Use the batteries of the equal capacity for the machine and booster supply.
- Check booster cables and end clips for signs of damage and corrosion.
- Connect the clips positively.

### 3. PERIODICAL MAINTENANCE

#### 3.1 Precautions

Whether or not the inspection service and lubrication are performed at the correct regular intervals exerts significant influence on the occurrence of trouble and service life of the machine. In this manual, typical intervals for inspection and service are given. However, flexibility should be introduced as to interval or type of services to enable your machine to always operate in the best condition.

##### General precautions:

- (1) Always use Sakai genuine parts for replacement.
- (2) Use lubricants recommended by Sakai. Avoid mixing different brand lubricants.
- (3) For hydraulic oil replenishment, changing, level checking, filter cleaning or replacement, oiling and greasing, use extreme care to prevent dust from entering.
- (4) For checking oil level or changing oil, park the machine on a level and hard surface.
- (5) Change oil while its temperature remains high after operation.
- (6) For a long-term storage, fill the fuel tank, lubricate necessary points and run the machine for more than 20 minutes once a month.
- (7) For the hydraulic pump and motor, have them serviced at authorized service shops.
- (8) Turn the starter switch OFF when performing services such as repairing broken wires, short circuits and tightening loose terminals.

##### **▲ CAUTION**

- With a new machine, change the engine oil (See page 47) and change the engine oil filter cartridge (See page 48) after 50 hours of operation for the first time only.
- When trouble occurs in the engine oil level by the indicator lamp on the control panel, sensor will work and corresponding lamp comes on. If this occurs, conduct necessary service regardless of the periodical service interval recommendation.
  - 1) Engine oil warning lamp ⇒ Add engine oil as necessary
- Check the electric wiring at a regular interval not exceeding one month:
  - 1) Damage to the wire harness and loose clamps
  - 2) Loose sockets
  - 3) Function of electrical systems



### 3.2 Walk-around Checking

For efficient operation, daily, before-operation checking is very important. Before starting, perform walk-around checking for loose bolts, nuts and signs of leakage in addition to items as shown below:

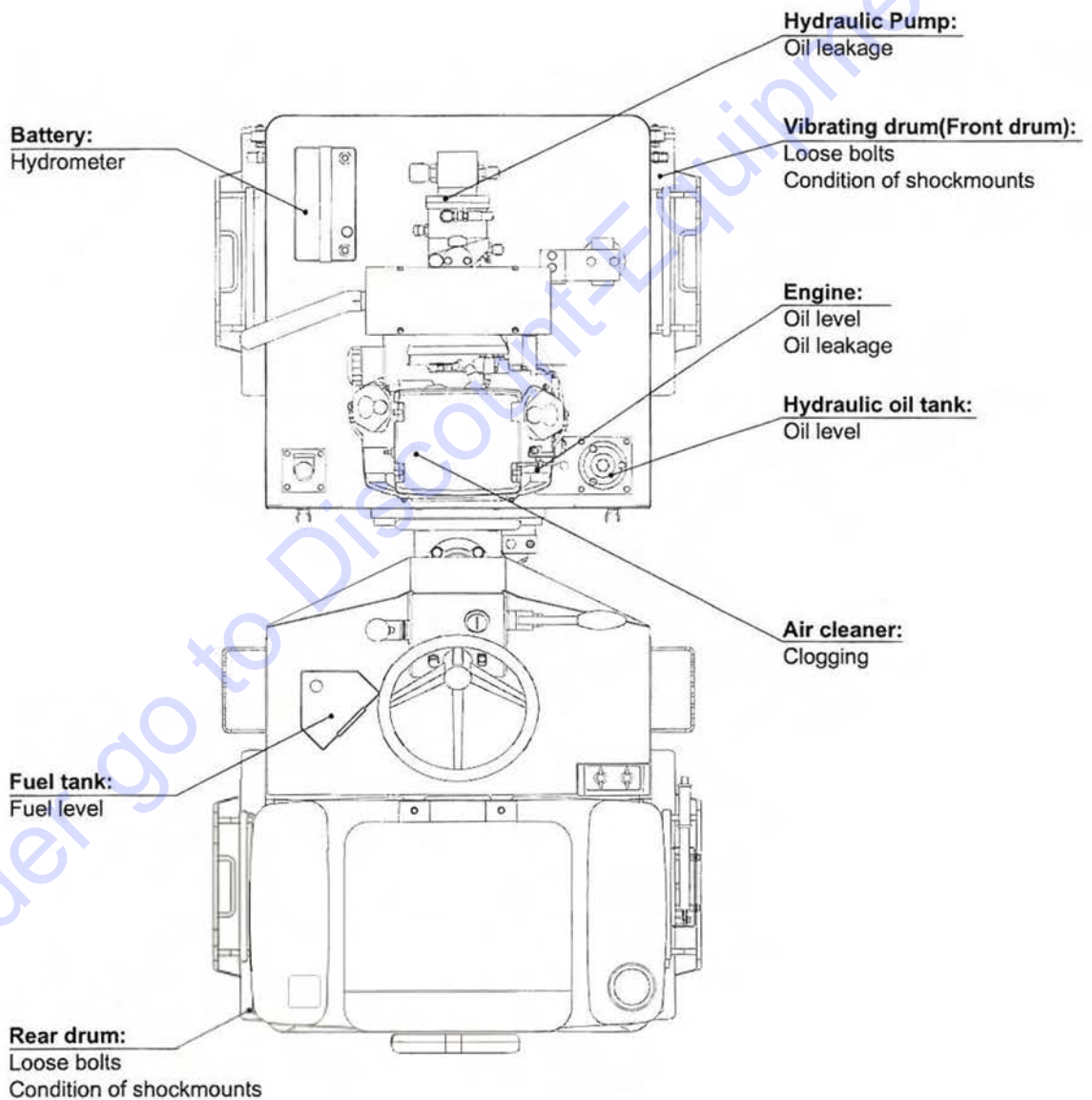

3. PERIODICAL MAINTENANCE

3.3 Periodical Maintenance Points

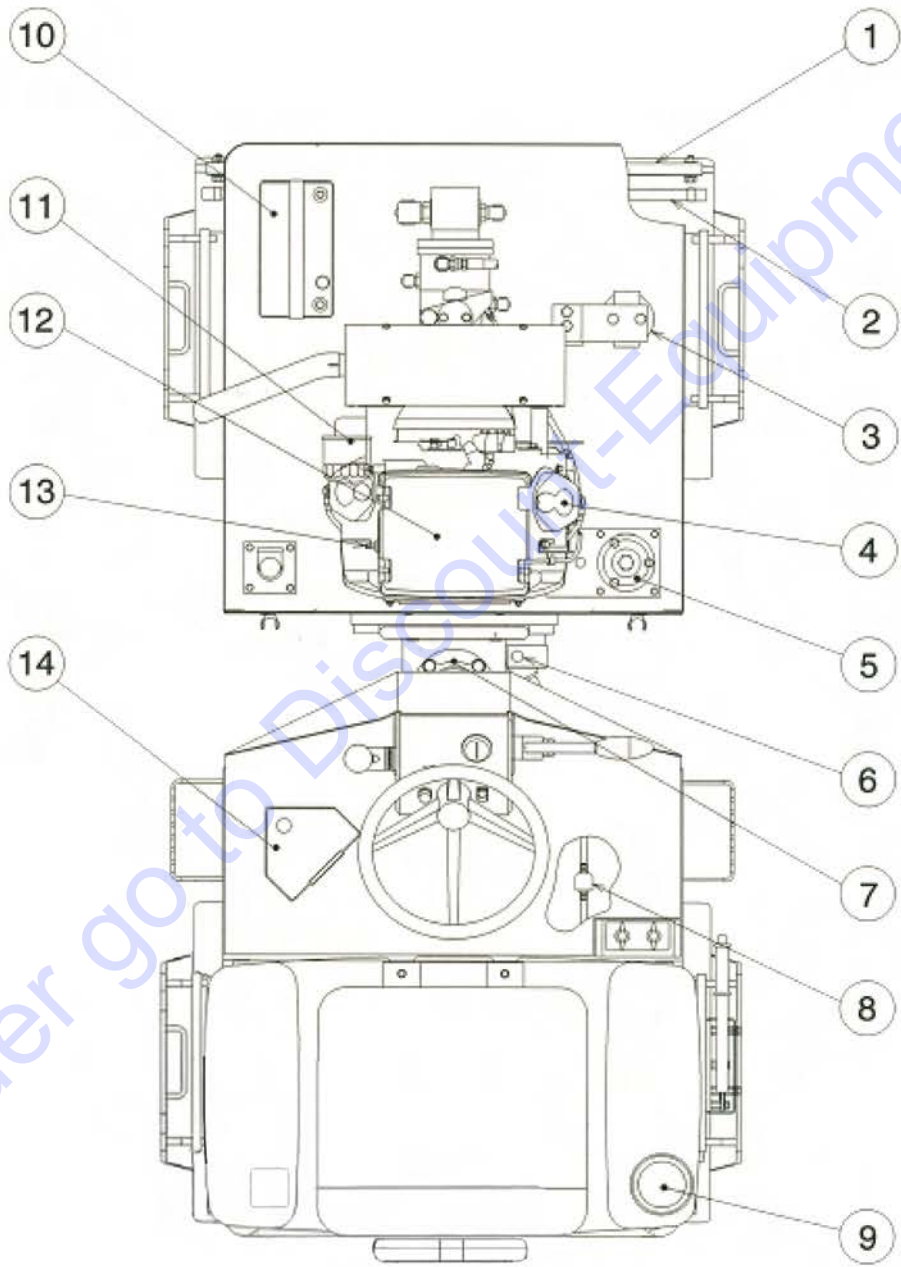

### 3. PERIODICAL MAINTENANCE

Interval	Ref. No.	Item	Service	Lubricant	Q'ty
Every 10 hours or daily	④	Engine oil pan	Check oil level, add as necessary	Engine oil	1
	⑭	Fuel tank	Check fuel level, add as necessary	Gasoline	1
Every 50 hours	⑤	Hydraulic tank	Check fluid level, add as necessary	Hydraulic oil	1
	⑥	Cylinder pin	Apply grease	Grease	2
	⑦	Center pin	Apply grease	Grease	2
Every 100 hours	④	Engine oil pan	Change oil	Engine oil	1
	⑩	Battery	Check looseness of mounting and terminal		1
Every 250 hours	④	Engine oil pan	Change oil	Engine oil	1
	⑧	Fuel filter	Change element		1
	⑪	Engine oil filter	Change element		1
	⑬	Fuel filter	Change element		1
Every 500 hours	③	Line filter	Change element		1
	⑤	Hydraulic tank	Change element, wash inside	Hydraulic oil	1
As required	①	Scraper	Adjust or change blade		4
	②	Sprinkler pipe	Clean or change		2
	⑨	Sprinkler tank	Clean inside		1
	⑫	Air cleaner	Clean element or change		1
	⑭	Fuel tank	Clean inside		1

### 3. PERIODICAL MAINTENANCE

#### 3.4 Maintenance Procedure

➔ For servicing the engine, see the separate engine manual.

##### (1) Every 10 hours or daily

###### ④ Engine oil pan

Check the engine oil level with the engine shut down. Add the engine oil from the fill port if the level is not within the permissible range (MAX~MIN).

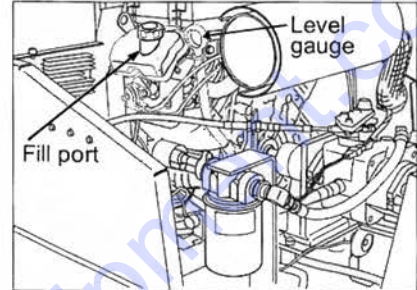

###### ⑭ Fuel tank

Check the fuel level with the fuel gauge or the level gauge. Add as necessary fill port.

#### ⚠ CAUTION

For refueling, park the machine on a level and solid surface.

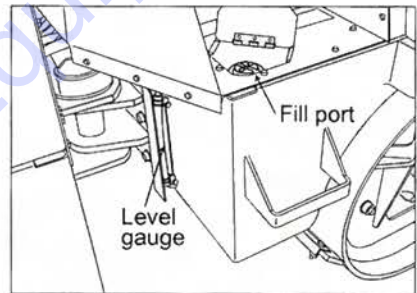

##### (2) Every 50 hours

###### ⑤ Hydraulic tank

Check the oil level with the sight glass on the side of tank. The level is proper if it is between H and L marks. If necessary, add the hydraulic fluid from the fill port.

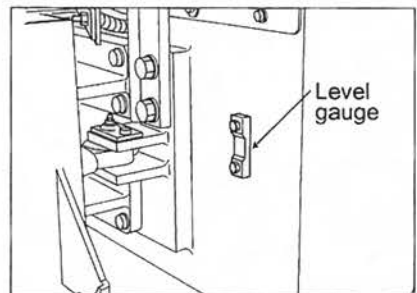

###### ⑥ Cylinder pin

Grease the fittings.

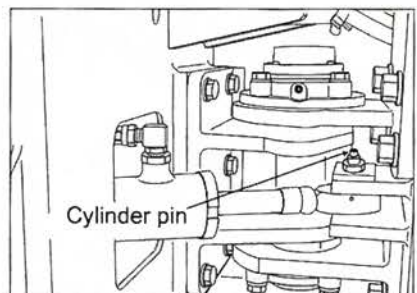

⑦ Center pin

Grease the fittings.

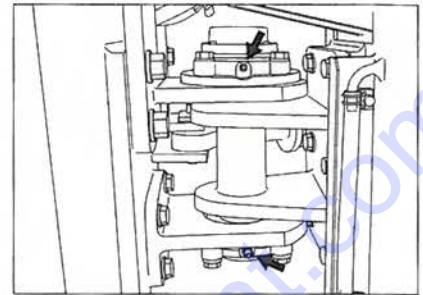

(3) Every 100 hours

④ Engine oil pan

➔ See the separate engine manual.

- 1) After completion of operation and while the oil is warm, drain the oil with the drain plug removed.
- 2) Refit the drain plug and fill the crankcase with the engine oil from the fill port.



**NOTE:** For a new machine, change oil filter element at 50 operating hours for the initial time only.

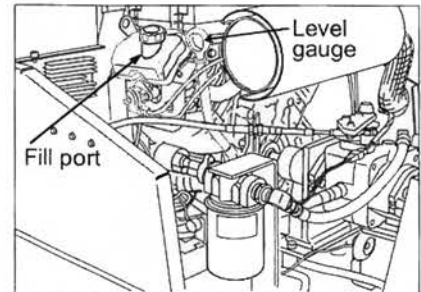

⑩ Battery

- (1) Check the condition of the battery and replace it as necessary.  
Check the color of the hydrometer at top of the battery to confirm the condition of the battery.  
Green.....Satisfactory  
Black.....Charging is necessary  
Semitransparent...Replacement is necessary
- (2) When the terminal is loose, tighten it sufficiently, and thinly apply vaseline or grease to prevent rusting.

### 3. PERIODICAL MAINTENANCE

#### (4) Every 250 hours

④ Engine oil pan

⑪ Engine oil filter

➔ See the separate engine manual.

- 1) After completion of operation and while the oil is warm drain the oil with the drain plug removed.

#### ⚠ WARNING

When draining a hot oil, use care not to get burned.

- 2) Refit the drain plug and fill the crankcase with the engine oil from the fill port.
- 3) Change the oil filter cartridge.

**NOTE:** For a new machine, change oil filter cartridge at 50 operating hours for the initial time only.

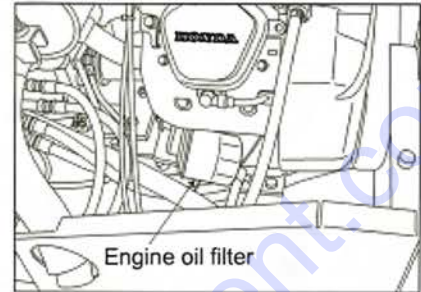

⑧ Fuel filter

➔ See the separate engine manual.  
Change the fuel filter.

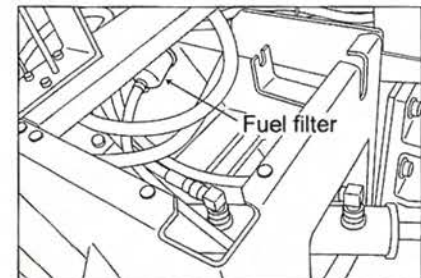

⑬ Fuel filter

➔ See the separate engine manual.  
Change the fuel filter.

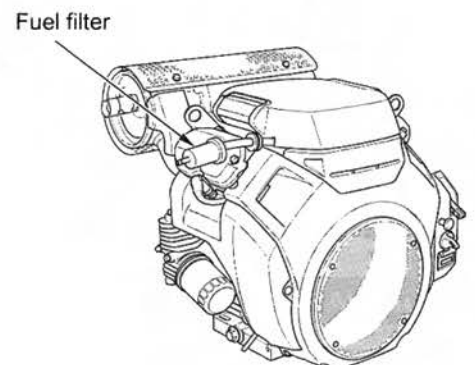

(5) Every 500 hours

③ Line filter

Remove the filter case by turning counter-clockwise as viewed from the bottom, and change the element.

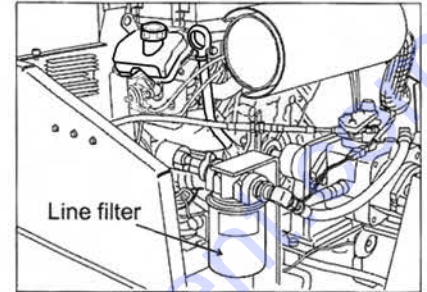

⑤ Hydraulic tank

- 1) Remove the drain plug, and drain oil while it is warm.
- 2) Clean inside of the tank, and fill fresh oil to the specified level.
- 3) Start and run the engine at idling for 2 to 5 minutes. When the hydraulic oil has become free from air bubbles, stop the engine and recheck the oil level.

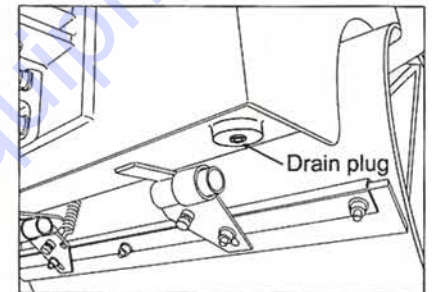

(6) As required

① Scraper

When the gap between the drum and blade has grown large, adjust the scraper properly. To clear muds accumulated between the drum and scraper blade, raise the blade.

**⚠ WARNING**

**Be careful not to pinch your fingers between the drum and blade.**

See page 24 for adjustment.

② Sprinkler pipe

Clean or change.

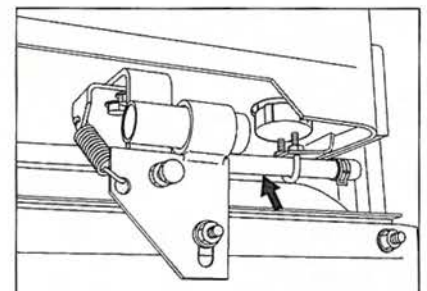

### 3. PERIODICAL MAINTENANCE

#### ⑨ Sprinkler tank

Open the drain cap at the bottom of the tank and feed water through the fill port to clean the inside of the tank. When cleaning is complete, close the valve.

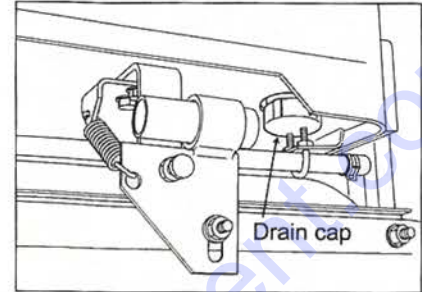

#### ⑫ Air cleaner

Clean the element as described below:

- 1) Pull the air cleaner cover latch to the unlocked position, and remove the cover.
- 2) Remove the wing nut from the filter element assy.
- 3) Remove the filter element assy from the air cleaner case.
- 4) Inspect both filter elements, and replace them if they are damaged. Always replace the filter element assy at the scheduled interval.

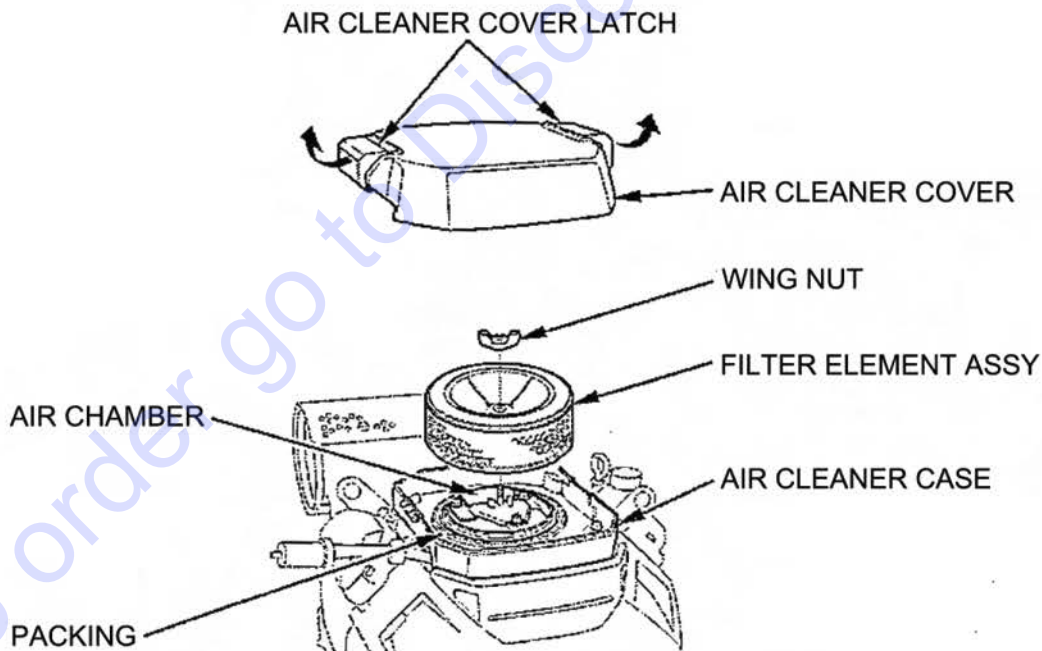

#### **⚠ WARNING**

Exercise caution not to get a speck of dust in your eye.

**NOTE:** Change the element once in every six cleanings.



## ⑭ Fuel tank

- 1) With the drain plug removed, remove the water and sediment from the bottom of the tank.
- 2) If sedimentation is substantial, remove the drain plug and clean the interior of the tank.
- 3) When the necessary work and refueling are complete, tighten the filler cap positively.

**NOTE:** When removing the water and sediment from the tank filled with the fuel, the fuel will gush out if the drain plug is screwed out completely.

**⚠ WARNING**

- The fuel will catch fire if open flames or ignition sources are used close to it.
- Do not smoke or use a match or cigarette lighter close to it.



### 3.5 Feeding Water and Lubricants

#### 1. General rules

- 1) Never feed water or lubricant with the strainer removed.
- 2) Use recommended lubricant and hydraulic fluid.
- 3) Do not use lubricants and hydraulic fluid of different brands.
- 4) When replacing oil, drain it completely and clean the container with flushing oil before filling new oil.

#### 2. Capacity

Compartment	Type of fluid	Capacity in liters (gal.)
Fuel tank	Gasoline	30 (7.9)
Engine oil pan	Engine oil	1.9 (0.5)
Hydraulic tank	Hydraulic oil	30 (7.9)
Sprinkler tank	Water	150 (40)

### 3. PERIODICAL MAINTENANCE

#### 3. Rating

Lubricant	Service classification	Ambient temp. and applicable viscosity rating			Applicable standards
		-30 ~ 0°C Cold	-20 ~ 40°C Moderate	10 ~ 40°C Tropical	
Engine oil	API grade SF or SG	SAE 5W-30	SAE 10W-30	SAE 30	MIL-L-2104C
Gear oil	API grade GL4	SAE 80W-90	SAE 90	SAE 140	MIL-L-2105
Hydraulic oil	Wear resistant	ISO-VG32 over VI 140	ISO-VG46 over VI 140	ISO-VG68 over VI 110	ISO-3448
Grease	Lithium type extreme pressure				NLGI-2
Fuel	Gasoline				JIS • K2202-2

#### 4. Recommended lubricants

Lubricant Oil company	Engine oil API – CC	Gear oil API GL 4	Hydraulic oil VG 46	Grease (NLGI – II)
CALTEX	RPM DELO 300 oil	Universal Thuban 90	Rando Oil HD 46	Martifack EP 2
BP	BP Vanellus C3-30	BP Gear Oil EP 90	BP Energol HLP 46	BP Energrease LS – EP 2
ESSO	Esso Lube D3-30	Esso Gear Oil GP 90	Nuto H 46	Beacon EP 2
MOBIL	Mobil Delvac 1330	Mobil Pegasus Gear Oil 90	Nuto Oil 25	Beacon EP 25
SHELL	Shell Rotella CT Oil 30	Shell Spirax 90 EP	Shell Tellus Oil 48	Shell Alvania EP Grease 2
CASTROL	Castrol CRD 30	Castrol Hypoy 90	Hyspin AWS 46	Spherrol ELP 2

**CAUTION:** (1) Fill the fluid reservoirs with the filters installed.  
 (2) Use recommended fuels and lubricants only.

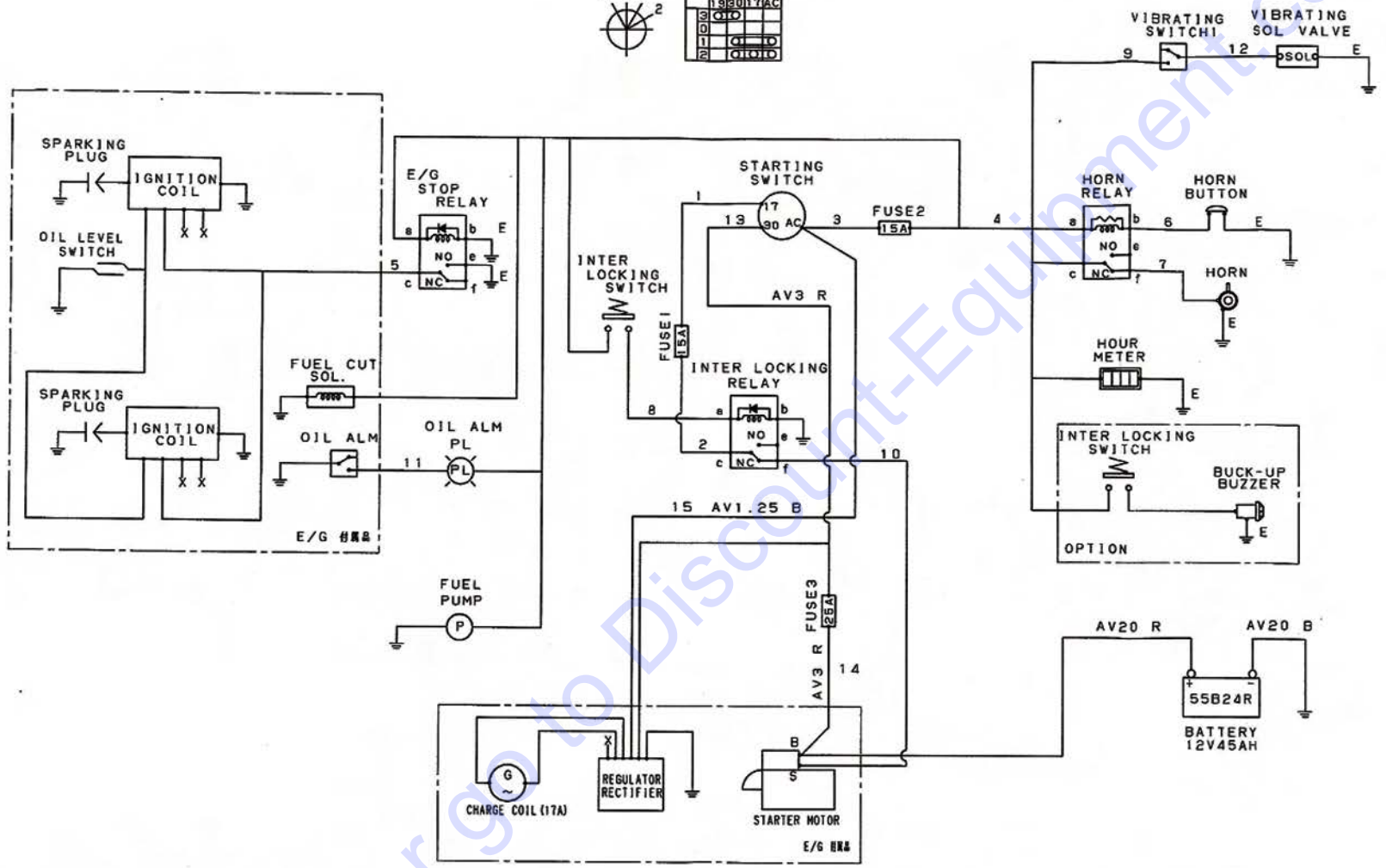
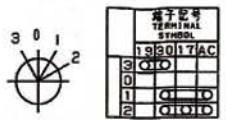

3.6 Electric Wiring Diagram

3. PERIODICAL MAINTENANCE

CAUTION: Size of wires not indicated by letters are AV 0.85.

Color of wire

B	Black	BrR	Brown/Red stripe	GR	Green/Red stripe	LR	Blue/Red stripe	P	Pink	RW	Red/White stripe	WR	White/Red stripe	YR	Yellow/Red stripe	LB	Blue/Black stripe
BR	Black/Red stripe	BrW	Brown/White stripe	GW	Green/White stripe	LW	Blue/White stripe	R	Red	RY	Red/Yellow stripe	Y	Yellow	YW	Yellow/White stripe	WG	White/Green stripe
BW	Black/White stripe	G	Green	GY	Green/Yellow stripe	LY	Blue/Yellow stripe	RB	Red/Black stripe	W	White	YB	Yellow/Black stripe	BrY	Brown/Yellow stripe		
BY	Black/Yellow stripe	GB	Green/Black stripe	Gr	Gray	Lg	Light green	RG	Red/Green stripe	WB	White/Black stripe	YG	Yellow/Green stripe	Sb	Blue		
Br	Brown	GL	Green/Blue stripe	L	Blue	O	Orange	RL	Red/Blue stripe	WL	White/Blue stripe	YL	Yellow/Blue stripe	BG	Black/Green stripe		

OPTION

### 3. PERIODICAL MAINTENANCE

#### **Fuse box**

The fuse is housed in the fuse holder on the way of a wiring. Be sure to use fuses of correct capacity consulting the the electric wiring diagram(see page 53).

**NOTE:** When a fuse is burned, determine the cause befor replacing.

#### **Battery**

- ★ When the battery is left unused for a long time or the electricity is used too much, the pole plates will be damaged, shortening its service life extremely.
- ★ When the battery will not be used for a long time, charge it sufficiently, leave it in the shade in a cool, dry place, and check its condition every month.
- ★ Keep the battery in a satisfactory condition at all times.
- ★ The battery should be in a satisfactory condition when the engine is to be started on cold days. Avoid starting the engine with the battery in a poor condition at any time.

4. SPECIFICATIONS

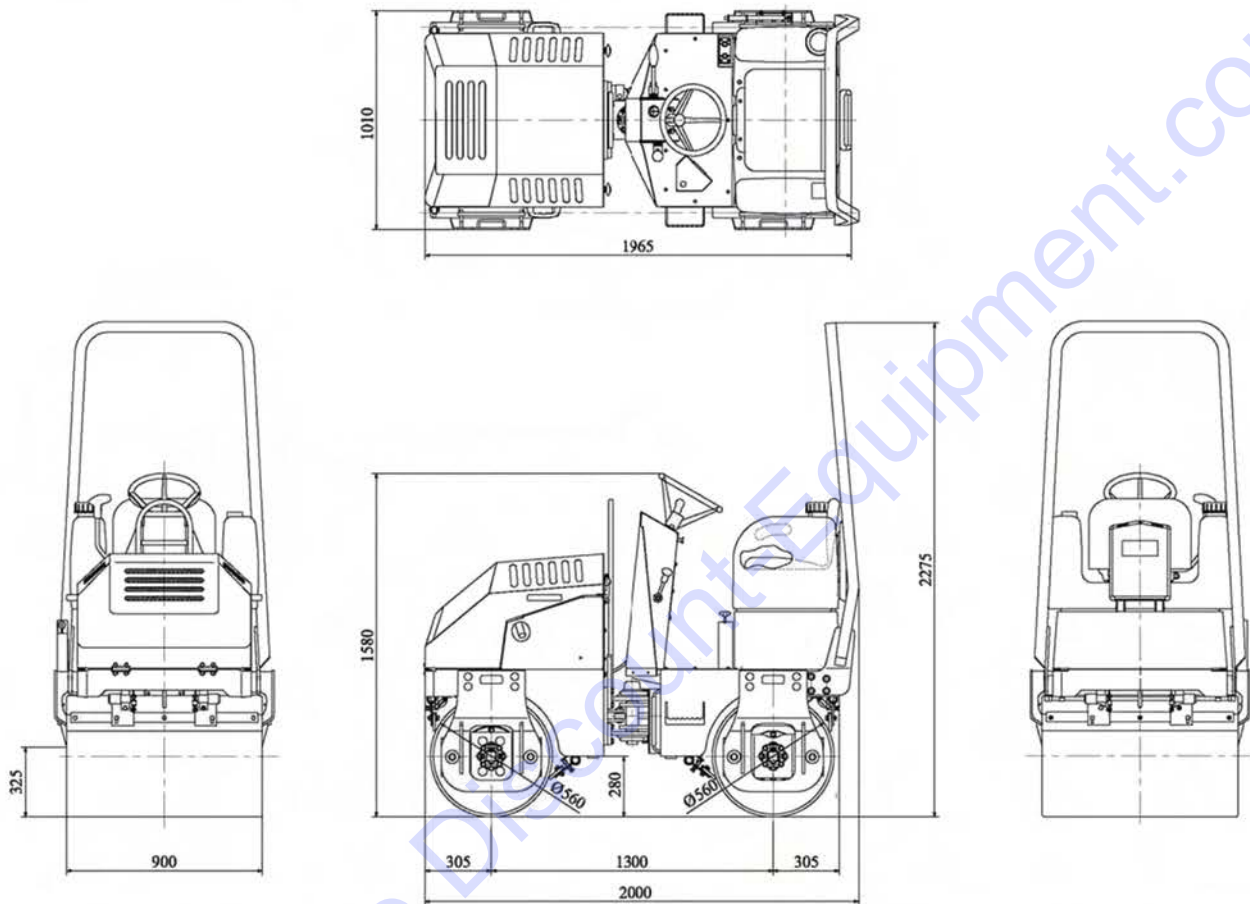

<b>Model</b>	CR271	<b>Vibrating power:</b>	
<b>Weight:</b>		Frequency	66.7 Hz {4,000 vpm}
Gross weight	1,480 kg (3,265 lbs)	Centrifugal force	13.2kN {1,350kgf}(2,975 lbs)
Empty weight	1,330 kg (2,935 lbs)	Gradability	15 degrees
<b>Dimension:</b>		Rolling width	900 mm (35")
Overall length	2,000 mm (79")	Minimum turning radius	2.8 m (110")
Overall width	1,010 mm (40")	<b>Engine:</b>	
Overall height		Model	HONDA "GX630R" Engine
with Steering wheel	1,580 mm (62")	Total displacement	0.688 liters {688 cc}(42.0 cu.in)
with ROLL BAR	2,275 mm (90")	Rated output	12.0 kW {16.1 PS}/3,600 min <sup>-1</sup> (16.1 HP/3,600 rpm)
Wheelbase	1,300 mm (51")	Max. torque	48.3N·m {49.3 kgf·m}/2,500 min <sup>-1</sup> (35.6 ft-lbs/2,500 rpm)
Wheel		<b>Tank capacity:</b>	
Front	Roll (dia. x width) 560 × 900 mm (22" × 35")	Fuel tank	30 litres (7.9 gal)
Rear	Roll (dia. x width) 560 × 900 mm (22" × 35")	Hydraulic tank	30 litres (7.9 gal)
<b>Performance:</b>		Sprinkler tank	150 litres (40 gal)
Travel speed (forward/reverse)	0 ~ 7.5 km/h (0 ~ 4.7 mile/h)		

**NOTE:** Gradability is the calculated value. It may vary with ground surface conditions.

**TO PURCHASE THIS PRODUCT PLEASE CONTACT US**



**Equipment Financing and  
Extended Warranties Available**



**Discount-Equipment.com is your online resource for  
commercial and industrial quality parts and equipment sales.**

**561-964-4949**

**visit us on line @ [www.discount-equipment.com](http://www.discount-equipment.com)**

Select an option below to find your Equipment

**Search by Manufacturer**

**Search by Product Type**

**Request a Quote**

We sell worldwide for the brands: Genie, Terex, JLG, MultiQuip, Mikasa, Essick, Whiteman, Mayco, Toro Stone, Diamond Products, Generac Magnum, Airman, Haulotte, Barreto, Power Blanket, Nifty Lift, Atlas Copco, Chicago Pneumatic, Allmand, Miller Curber, Skyjack, Lull, Skytrak, Tsurumi, Husquvarna Target, Stow, Wacker, Sakai, Mi-T-M, Sullair, Basic, Dynapac, MBW, Weber, Bartell, Bennar Newman, Haulotte, Ditch Runner, Menegotti, Morrison, Contec, Buddy, Crown, Edco, Wyco, Bomag, Laymor, EZ Trench, Bil-Jax, F.S. Curtis, Gehl Pavers, Heli, Honda, ICS/PowerGrit, IHI, Partner, Imer, Clipper, MMD, Koshin, Rice, CH&E, General Equipment, Amida, Coleman, NAC, Gradall, Square Shooter, Kent, Stanley, Tamco, Toku, Hatz, Kohler, Robin, Wisconsin, Northrock, Oztec, Toker TK, Rol-Air, APT, Wylie, Ingersoll Rand / Doosan, Innovatech, Con X, Ammann, Mecalac, Makinex, Smith Surface Prep, Small Line, Wanco, Yanmar