

REVISED STARTING SERIAL # 2000



GASOLINE POWERED
TRAFFIC LINE REMOVER
PARTS LIST MANUAL



MODEL TLR7-11H
PART #77500



PARTS FINDER

**Search Website
by Part Number**



**Search Manual
Library For Parts
Manual & Lookup Part
Numbers – Purchase
or Request Quote**

Search Manuals

Enter your information to help us find the right parts manual for your machine.

* Brand:

* Model:

* Serial:

* Part Number:

SEARCH

**Can't Find Part or
Manual? Request Help
by Manufacturer,
Model & Description**

Parts Order Form

Please fill in the following information to help us find the right part for your machine.

Manufacturer:	<input type="text"/>
Model:	<input type="text"/>
Description:	<input type="text"/>
Part Number:	<input type="text"/>
Quantity:	<input type="text"/>
Notes:	<input type="text"/>

Submit

Discount-Equipment.com is your online resource for quality parts & equipment.

Florida: **561-964-4949** Outside Florida TOLL FREE: **877-690-3101**

Need parts?

Click on this link: <http://www.discount-equipment.com/category/5443-parts/> and choose one of the options to help get the right parts and equipment you are looking for. Please have the machine model and serial number available in order to help us get you the correct parts. If you don't find the part on the website or on one of the online manuals, please fill out the request form and one of our experienced staff members will get back to you with a quote for the right part that your machine needs.

We sell worldwide for the brands: Genie, Terex, JLG, MultiQuip, Mikasa, Essick, Whiteman, Mayco, Toro Stone, Diamond Products, Generac Magnum, Airman, Haulotte, Barreto, Power Blanket, Nifty Lift, Atlas Copco, Chicago Pneumatic, Allmand, Miller Curber, Skyjack, Lull, Skytrak, Tsurumi, Husquvarna Target, Stow, Wacker, Sakai, Mi-T-M, Sullair, Basic, Dynapac, MBW, Weber, Bartell, Bennar Newman, Haulotte, Ditch Runner, Menegotti, Morrison, Contec, Buddy, Crown, Edco, Wyco, Bomag, Laymor, EZ Trench, Bil-Jax, F.S. Curtis, Gehl Pavers, Heli, Honda, ICS/PowerGrit, IHI, Partner, Imer, Clipper, MMD, Koshin, Rice, CH&E, General Equipment, Amida, Coleman, NAC, Gradall, Square Shooter, Kent, Stanley, Tamco, Toku, Hatz, Kohler, Robin, Wisconsin, Northrock, Oztec, Toker TK, Rol-Air, APT, Wylie, Ingersoll Rand / Doosan, Innovatech, Con X, Ammann, Mecalac, Makinex, Smith Surface Prep, Small Line, Wanco, Yanmar

READ AND UNDERSTAND THE OPERATORS INSTRUCTION MANUAL THOROUGHLY BEFORE ATTEMPTING TO OPERATE THIS EQUIPMENT. Death or serious injury could occur if this machine is used improperly.



SAFETY MESSAGES



The safety instructions are preceded by a graphic alert message of DANGER, WARNING, or CAUTION.



Indicates an imminent hazard which, if not avoided, will result in death or serious injury.



Indicates an imminent hazard which, if not avoided, can result in death or serious injury.



Indicates hazards which, if not avoided, could result in serious injury and or damage to the equipment.

GASOLINE

Powered Equipment



- Do not operate gasoline powered equipment without adequate ventilation. Carbon monoxide is an invisible, odorless gas that can kill.

ELECTRICAL

Powered Equipment



- ELECTRICAL HAZARD** - Be sure equipment is properly grounded. Failure to comply could kill or result in serious injury.



The engine exhaust from this product contains chemicals known to the State of California to cause cancer, birth defects or other reproductive harm.

GENERAL INSTRUCTIONS



- You must read and understand the operators instruction manual and all other manuals associated with this machine. For your safety and the safety of others around you, it is extremely important to fully understand how to operate this machine in the way it was intended. Different model machines or older/newer versions of the same model may have different parts and controls that you need to understand. If instructions are not readable or available DO NOT USE this machine and contact Discount-equipment for a replacement Manual.
- You must be able to physically handle the bulk weight and power of this machine. If not properly controlled this machine can cause death or serious injury.
- Do not operate this machine in an impaired mental state. You must be able to exercise good judgement and reactions to maintain a safe working environment.
- This is a "one person" machine which means only one operator can be operating the machine at any one time. For the safety of others, maintain a safe operating distance to other personnel. Your work area should be defined and appropriately marked so bystanders and coworkers do not stand or walk near this machine and end up seriously injured by flying debris or exposing them to harmful noise or dust.
- This equipment is for Commercial use. Although this is a "one person" machine your work team should understand how to shut this machine off and quickly get medical help if an accident strikes the operator.
- Keep all guards in place during operation. The guards are to provide protection from inadvertent contact with dangerous moving parts, pinch points, or hot surfaces.
- Wear appropriate Personal Protective Equipment (PPE) including safety glasses, safety boots, work gloves, respiratory protection,

hearing protection, and head protection. Do not wear loose clothing that can get tangled in moving parts. Failure to do so could result in dismemberment or death. **Wear an approved respirator when removing hazardous materials or when grinding/cutting dry materials. Some dust particles such as concrete dust can contain silicate particles which can cause silicosis (a very serious lung disease). Contact NIOSH or OSHA for further details. When wet grinding/cutting, avoid contact with the concrete/asphalt slurry which can cause serious skin irritations.**

- You must maintain this machine per the maintenance schedule in the operator manual. Remember before adjusting, servicing, or fueling this machine, disconnect the source of power to the machine by disconnecting the spark plug (Gas models), or by unplugging the electrical power cord (electric models) or air hose (Pneumatic models) AT THE MACHINE so you can assure yourself it remains unplugged while you are working on it. Do not modify this machine. Use only genuine EDCO parts and accessories. Repairs and service should be performed by approved EDCO dealers or authorized technicians.
- You should look carefully around the area before you begin work so you can identify potential hazards such as deck inserts, pipes, columns, openings, electrical cords or outlets, or any other objects protruding from the slab surface.
- This machine has no brain so you must use your own. There is no substitute for safety. The safety decals on the machine are to serve as a reminder for information you must already know before you begin using this machine. Take a moment to reread the safety decals each time you use the machine. If your machine is missing any decals, contact Discount-equipment for a replacement.

PARTS LIST MANUAL

MODEL TLR-7

Section	Page Number
Safety Messages / General Instructions	2
How To Order Replacement Parts	3
Illustration 1: Outer Frame Grouping	4,5
Illustration 2: Inner Frame Grouping	6,7
Illustration 3: Rotary Cutter Head Grouping	8,9
Illustration 4: Engine & Belt Drive Grouping	10,11
Limited Equipment Warranty	back cover

Go to Discount-Equipment.com to order your parts



ILLUSTRATION 1 : OUTER FRAME GROUPING

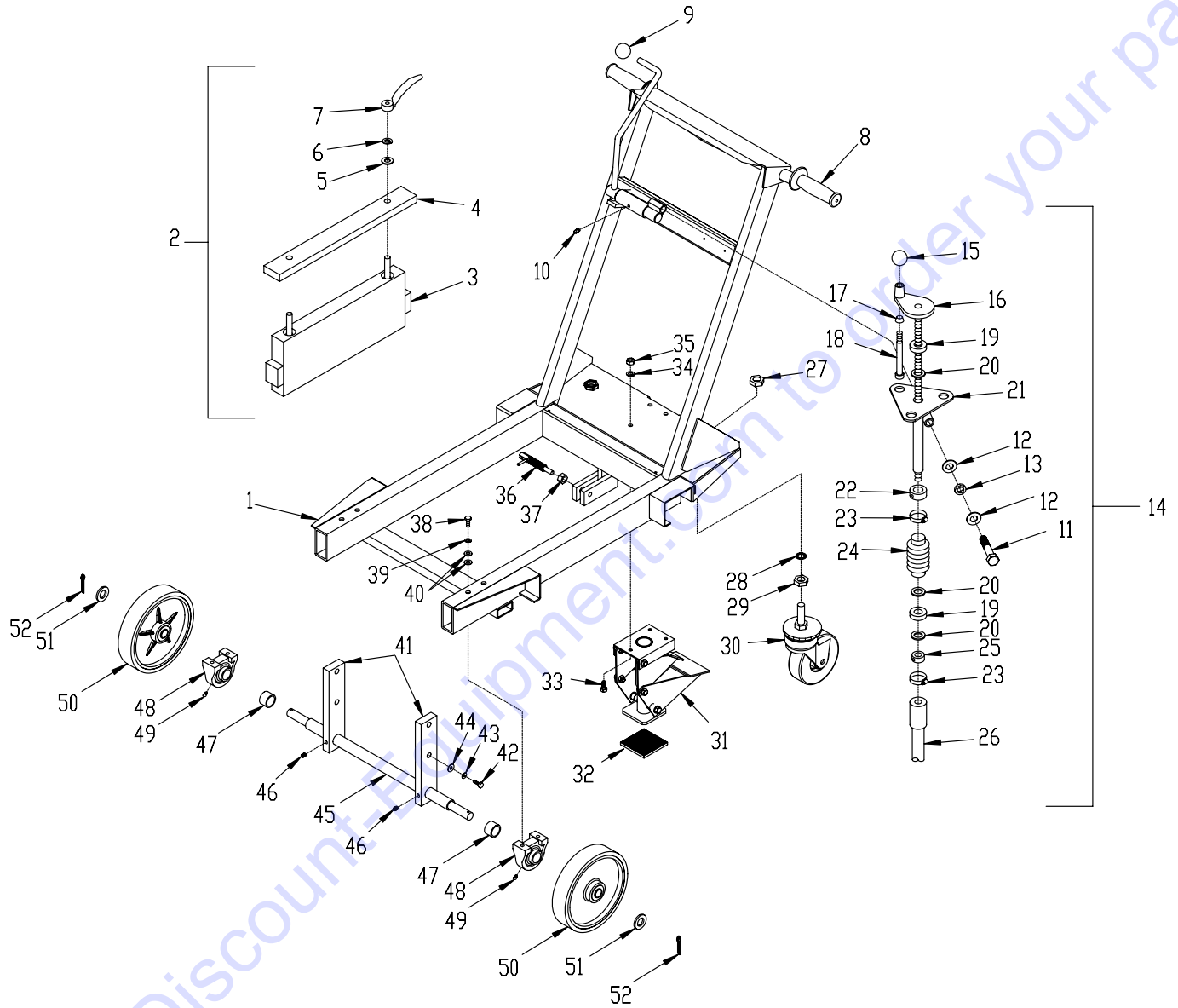

PARTS LISTING - ILLUSTRATION 1 : OUTER FRAME GROUPING

ITEM#	PART#	DESCRIPTION	QTY.	ITEM#	PART#	DESCRIPTION	QTY.
1	68022	OUTER FRAME W/ HANDLE	1	27	68058	NUT, HEX NYLON JAM 3/4-10	2
2	68060	WEIGHT UNIT, 48 LB. (INCLUDES ITEMS 3-7)	2	28	10609	WASHER, LOCK, INT. TOOTH 3/4"	2
3	68037	WEIGHT, 41 LB.	2	29	10403	NUT, JAM 3/4-10	2
4	68038	WEIGHT BAR, 7 LB.	2	30	68020A	CASTER, SWIVEL, 5"WHEEL W/ 3/4-10 STEM	2
5	10312	WASHER, FLAT 1/2	4	31	68036	KICK STAND ASSY.	1
6	10045	WASHER, LOCK 1/2	4	32	68007	PAD, RUBBER, KICK STAND	1
7	68040	NUT, TAIL HANDLE 1/2-13	4	33	10053	SCREW, CAP 5/16-18 X 3/4	3
8	61108	GRIP, HAND 1" MODEL SX	2	34	10801	WASHER, LOCK 5/16	3
9	14023	KNOB, BALL 1-3/8 W/ 1/2-13THD, BLK.	1	35	10054	NUT 5/16-18	3
10	10953	FITTING, GREASE 1/8NPT STRAIGHT	1	36	68081	PLUNGER, SPRING 5/8-11 THD.	1
11	10359	SCREW, CAP 5/8-11 X 3-1/4	1	37	10046	NUT 5/8-11	1
12	10073	WASHER, FLAT 5/8	2	38	10318	SCREW, CAP 3/8-16 X 3-3/4	4
13	79035	BUSHING, RUBBER 1-1/16"OD X 5/8"ID	1	39	10811	WASHER, LOCK 3/8	4
14	68087	HANDWHEEL & LINKAGE SUBASSY.	1	40	10025	WASHER, FLAT 3/8	8
15	14023	KNOB, BALL 1-3/8 W/ 1/2-13THD, BLK.	1	41	68046	HOLDER, FRONT AXLE	2
16	65008	HANDWHEEL, SMALL W/ 5/8-8 X 18"ROD	1	42	10143	BOLT, TAP 1/2-13 X 1-1/2 (FULL THD)	4
17	50550	SLEEVE FOR 1/2" CAPSCREW, TAPERED	1	43	10045	WASHER, LOCK 1/2	4
18	10411	SCREW, SKT. HD. CAP 1/2-13 X 4 ZINC	1	44	10312	WASHER, FLAT 1/2	4
19	85005	BEARING, THRUST BALL 5/8	2	45	68045	AXLE SHAFT, FRONT 23"L	1
20	10073	WASHER, FLAT 5/8	3	46	10052	SCREW, SET 5/16-18 X 3/8	2
21	68086	LINKAGE SUPPORT, UPPER CONTROL	1	47	68047	SPACER, FRONT AXLE	2
22	10440	COLLAR, LOCKING 7/8"ID	1	48	50222	BEARING, BALL 1" TPB	2
23	10713	CLAMP, HOSE, SAE #24, ADJ. TO 2"	2	49	10006	FITTING, GREASE 1/8NPT X 45D	2
24	10930	BELLOWS 1-1/4ID X 2-3/8EL X 1-3/4RL	1	50	68008	WHEEL 8 X 1-5/8 X 3/4"BRG., POLY	2
25	10096	COLLAR, LOCKING 5/8"ID	1	51	10009	WASHER, FLAT 3/4	2
26	68043	LINKAGE, LOWER CONTROL 5/8-8 THD. (REFER TO ILLUS. 2, ITEM #13)	1	52	10306	PIN, COTTER 3/16 X 1-1/4	2

ILLUSTRATION 2 : INNER FRAME GROUPING

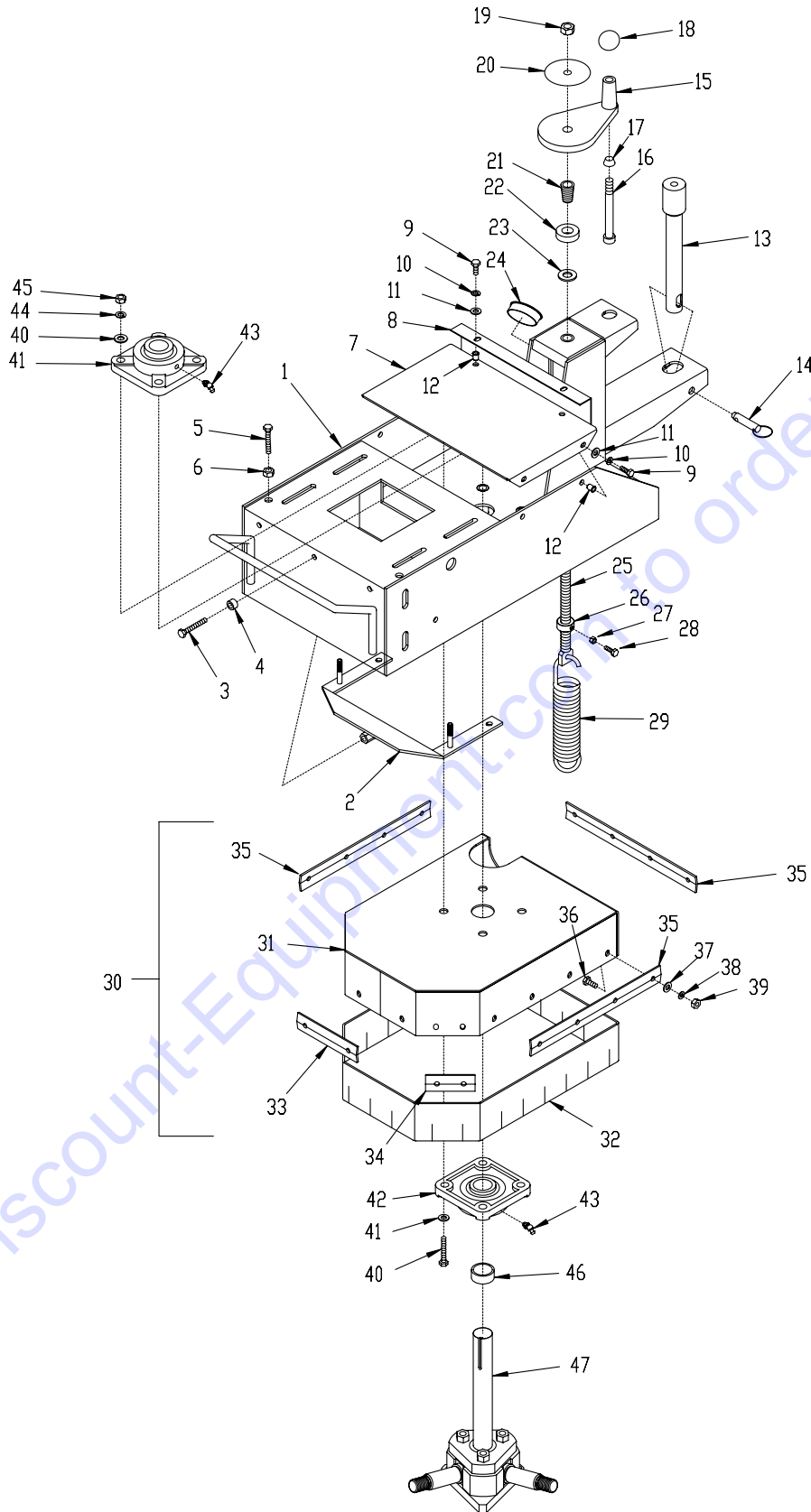

PARTS LISTING - ILLUSTRATION 2 : INNER FRAME GROUPING			
ITEM#	PART#	DESCRIPTION	QTY.
1	68021	FRAME, INNER	1
2	68035	TENSIONER, ENGINE (REFER TO ILLUS. 4-ITEM 10)	1
3	52015	BOLT, TAP 3/8-16 X 3-1/2(FULL THD.)	1
4	10011	SPACER, STEEL 5/8OD X 3/8ID X 3/8THK	1
5	10340	BOLT, TAP 1/2-13 X 3 (FULL THREAD)	2
6	10417	NUT 1/2-13	2
7	68057	COVER, BELT	1
8	68056	COVER REAR PANEL, BELT	1
9	10018	SCREW, CAP 1/4-20 X 3/4	8
10	10038	WASHER, LOCK 1/4	8
11	10602	WASHER, FLAT 1/4	8
12	10439	THREAD-SERT 1/4-20, BLIND RIVET	8
13	68043	LINKAGE, LOWER CONTROL 5/8-8 THD. (REFER TO ILLUS. 1, ITEM #26)	1
14	68082	PIN, DETENT RING 1/2 X 4 E.L.	1
15	68083	HANDWHEEL, LARGE W/ 7/8-9 THD.	1
16	10346	SCREW, SKT. HD. CAP 1/2-13 X 4-1/2 ZINC	1
17	50550	SLEEVE FOR 1/2" CAPSCREW, TAPERED	1
18	10104	KNOB, BALL 1-7/8 W/ 1/2-13THD., BLK.	1
19	10809	NUT, LOCK 5/8-11	1
20	68054	DECAL, PRESSURE CONTROL - MIN/MAX.	1
21	68084	THREAD INSERT 7/8-9 X 5/8-11	1
22	85005	BEARING, THRUST BALL 5/8	1
23	10073	WASHER, FLAT 5/8	1
24	64030	PLUG, CAP 3"	1
25	68085	LINKAGE, PRESSURE CONTROL 5/8-11	1
26	10096	COLLAR, LOCKING 5/8"ID	1
27	10464	NUT 1/4-28	1
28	10311	SCREW, CAP 1/4-28 X 1-3/4	1
29	41041	SPRING, EXT. 1.75"OD X 8"L	1
30	68025A	GUARD & SKIRT SUBASSEMBLY (INCLUDES ITEMS 31-39)	1
31	68025	GUARD, CUTTER HEAD	1
32	68030	SKIRT, RUBBER	1
33	68028	RETAINER, SKIRT 5-1/2"	1
34	68029	RETAINER, SKIRT 3-1/4"	2
35	68026	RETAINER, SKIRT 12"	3
36	10412	BOLT, CARRIAGE 1/4-20 X 1	18
37	10602	WASHER, FLAT 1/4	18
38	10038	WASHER, LOCK 1/4	18
39	10013	NUT 1/4-20	18
40	10409	SCREW, CAP 1/2-20 X 4-1/2	4
41	10312	WASHER, FLAT 1/2	8
42	68002	BEARING, BALL 1-1/4" 4-HOLE	2
43	10006	FITTING, GREASE 1/8NPT X 45D	1
44	10045	WASHER, LOCK 1/2	4
45	10205	NUT, LOCK 1/2-20	4
46	68019	SPACER, ROTARY HEAD MAIN SHAFT	1
47	68068	SPIDER ASSY., ROTARY HEAD (REFER TO ILLUS. 3 FOR BREAKDOWN)	1

ILLUSTRATION 3 : ROTARY CUTTER HEAD GROUPING

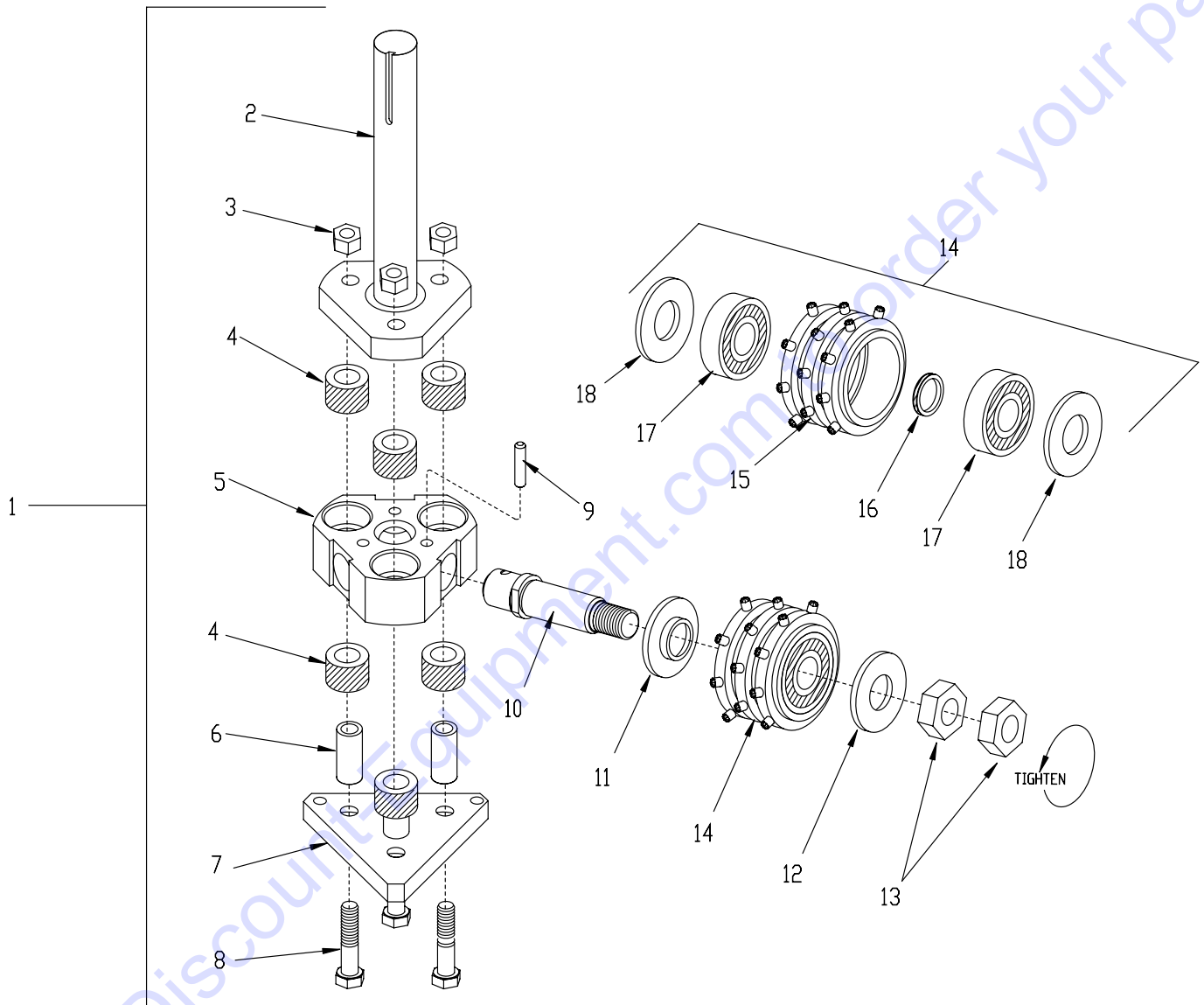

PARTS LISTING - ILLUSTRATION 3 : ROTARY CUTTER HEAD GROUPING			
ITEM#	PART#	DESCRIPTION	QTY.
1	68068	SPIDERASSY., ROTARY HEAD (INCLUDES ITEMS 2-10)	1
2	68011	SHAFT & FLANGE, ROTARY	1
3	10205	NUT, LOCK 1/2-20	3
4	68001	BUSHING, RUBBER 1-1/4 X 3/4 X 7/8	6
5	68065	HUB, ROTARY HEAD	1
6	68018	SLEEVE, RUBBER BUSHING	3
7	68013	FLANGE, ROTARY CUTTER HD BASE	1
8	10370	SCREW, CAP 1/2-20 X 3-1/4 (GRADE 8)	3
9	10126	PIN, ROLL 5/16 X 1-1/2	3
10	68066	SHAFT, ROTARY CUTTER	3
11	68067	FLANGE, ROTARY CUTTER INNER	3
12	68016	FLANGE, ROTARY CUTTER OUTER	3
13	10445	NUT, JAM 7/8-9 LEFT-HAND THREAD	6
14		TRI-CUT CARBIDE ASSEMBLY (SET OF 3)	1 SET
	26010	TR3-24 (24 CARBIDE PINS/CUTTER)	
	26020	TR3-48 (48 CARBIDE PINS/CUTTER)	
15		CUTTER, ROTARY	1 EA.
	68048	CUTTER ONLY, 24 CARBIDE PINS	
	68088	CUTTER ONLY, 48 CARBIDE PINS	
16	68017	SPACER 1-1/4"OD X 1"ID X 5/32"THK.	1 EA.
17	68004	BEARING, RADIAL BALL 25 X 62 X 17MM	2 EA.
18	68006	SEAL, FELT 2-1/2OD X 1-1/4ID X 3/16	2 EA.

ILLUSTRATION 4 : ENGINE & BELT DRIVE GROUPING

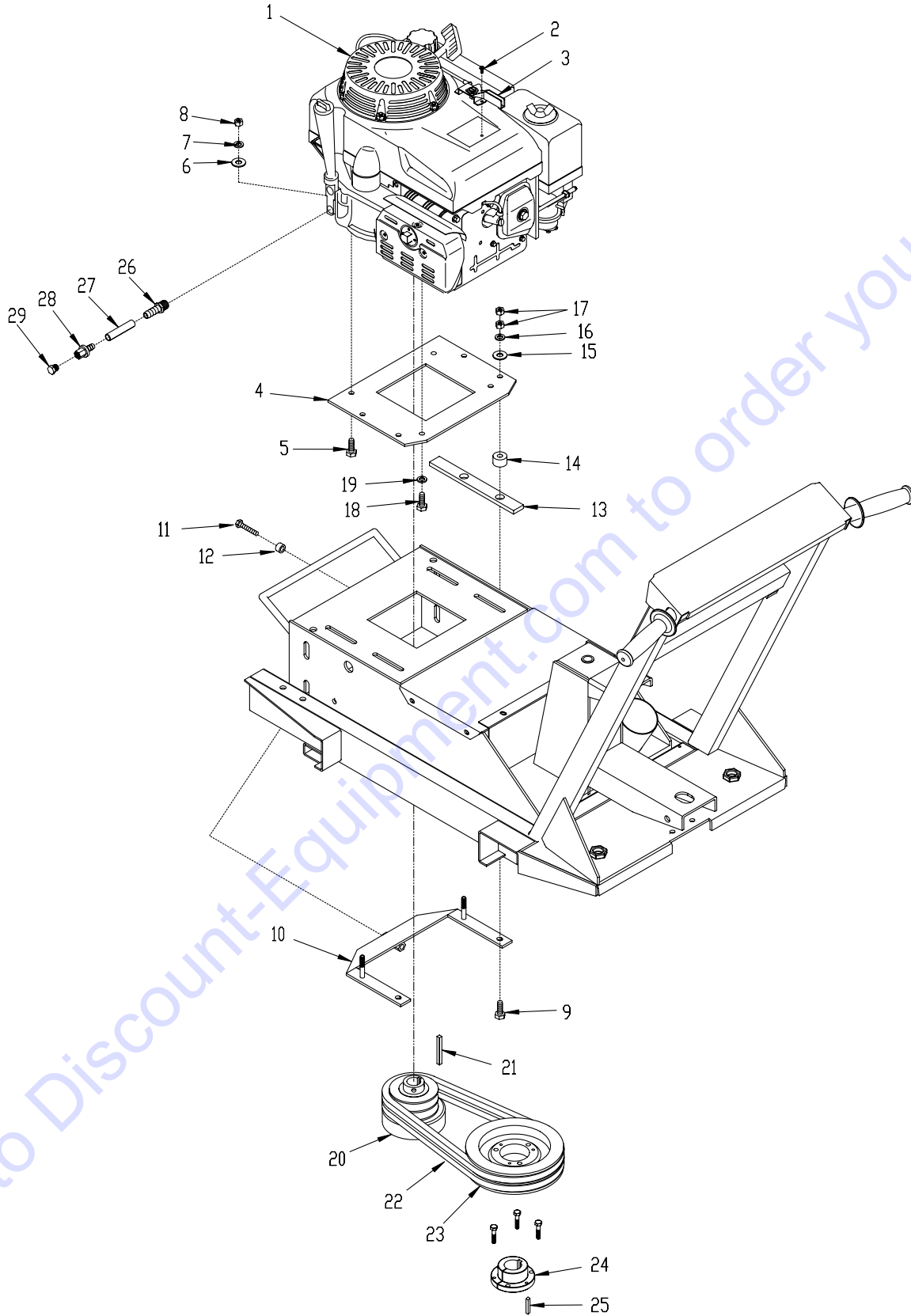

Go to Discount-Equipment.com to order your parts

PARTS LISTING - ILLUSTRATION 4 : ENGINE & BELT DRIVE GROUPING			
ITEM#	PART#	DESCRIPTION	QTY.
1	76004	ENGINE, HONDA 11 HP GXV340K2-DX3	1
2	10877	SCREW, CAP STSHW 10-24 X 1/2	2
3	40388	CABLE, THROTTLE, LEVER-TYPE 24" (TRIM TO 16")	1
4	68033	MOUNT PLATE, ENGINE	1
5	10606	SCREW, CAP 5/16-18 X 1-1/4	2
6	10213	WASHER, FLAT 5/16	2
7	10801	WASHER, LOCK 5/16	2
8	10054	NUT 5/16-18	2
9	10056	BOLT, CARRIAGE 5/16-18 X 2	2
10	68035	TENSIONER, ENGINE	1
11	52015	BOLT, TAP 3/8-16 X 3-1/2(FULL THD.)	1
12	10011	SPACER, STEEL 5/8OD X 3/8ID X 3/8THK	1
13	68034	SPACER, ENGINE MOUNT	2
14	10034	BUSHING, RUBBER 1"OD X 3/8ID X 5/8THK	4
15	10213	WASHER, FLAT 5/16	4
16	10801	WASHER, LOCK 5/16	4
17	10054	NUT 5/16-18	8
18	10048	SCREW, CAP 5/16-24 X 3/4	2
19	10801	WASHER, LOCK 5/16	2
20	76024	CLUTCH, CENTRIFUGAL 3.5 X 2GR X 1	1
21	-----	KEY 1/4 SQ. (INCLUDED W/ ENGINE)	1
22	10251	BELT BP-34 (REFER TO SERIAL NO. PLATE)	2
23	75010	SHEAVE 6.9"OD X 2GR.B X SDS	1
24	10064	BUSHING, SHEAVE SDS X 1-1/4"BORE	1
25	10305	KEY 1/4SQ X 1-1/4	1
26	11543	BARB, PUSH-ON 3/8HOSEX20MMX1.50	1
27	56116	HOSE, PUSH-ON 3/8"ID X 3"L	1
28	11544	BARB, PUSH-ON 3/8HOSE X 1/4FPT	1
29	10776	PIPE PLUG 1/4 NPT (BRASS)	1

PARTS FINDER

**Search Website
by Part Number**



**Search Manual
Library For Parts
Manual & Lookup Part
Numbers – Purchase
or Request Quote**

Search Manuals

Enter your information to help us find the right parts manual for your machine.

* Brand:

* Model:

* Serial:

* Part Number:

SEARCH

**Can't Find Part or
Manual? Request Help
by Manufacturer,
Model & Description**

Parts Order Form

Please fill in the following information to help us find the right part for your machine.

Manufacturer:	<input type="text"/>
Model:	<input type="text"/>
Description:	<input type="text"/>
Part Number:	<input type="text"/>
Quantity:	<input type="text"/>
Notes:	<input type="text"/>

Submit

Discount-Equipment.com is your online resource for quality parts & equipment.

Florida: **561-964-4949** Outside Florida TOLL FREE: **877-690-3101**

Need parts?

Click on this link: <http://www.discount-equipment.com/category/5443-parts/> and choose one of the options to help get the right parts and equipment you are looking for. Please have the machine model and serial number available in order to help us get you the correct parts. If you don't find the part on the website or on one of the online manuals, please fill out the request form and one of our experienced staff members will get back to you with a quote for the right part that your machine needs.

We sell worldwide for the brands: Genie, Terex, JLG, MultiQuip, Mikasa, Essick, Whiteman, Mayco, Toro Stone, Diamond Products, Generac Magnum, Airman, Haulotte, Barreto, Power Blanket, Nifty Lift, Atlas Copco, Chicago Pneumatic, Allmand, Miller Curber, Skyjack, Lull, Skytrak, Tsurumi, Husquvarna Target, Stow, Wacker, Sakai, Mi-T-M, Sullair, Basic, Dynapac, MBW, Weber, Bartell, Bennar Newman, Haulotte, Ditch Runner, Menegotti, Morrison, Contec, Buddy, Crown, Edco, Wyco, Bomag, Laymor, EZ Trench, Bil-Jax, F.S. Curtis, Gehl Pavers, Heli, Honda, ICS/PowerGrit, IHI, Partner, Imer, Clipper, MMD, Koshin, Rice, CH&E, General Equipment, Amida, Coleman, NAC, Gradall, Square Shooter, Kent, Stanley, Tamco, Toku, Hatz, Kohler, Robin, Wisconsin, Northrock, Oztec, Toker TK, Rol-Air, APT, Wylie, Ingersoll Rand / Doosan, Innovatech, Con X, Ammann, Mecalac, Makinex, Smith Surface Prep, Small Line, Wanco, Yanmar