



# PARTS LIST MANUAL

## MODEL BB14E



SHOWN WITH OPTIONAL FOLDING STAND

### 14" ELECTRIC MASONRY SAW

SKU #	MODEL #	POWER OPTION
22300	BB14E-1.5B	BALDOR ELECTRIC MOTOR 1.5HP 60Hz 1-PHASE 115/230V

# PARTS FINDER

**Search Website  
by Part Number**



**Search Manual  
Library For Parts  
Manual & Lookup Part  
Numbers – Purchase  
or Request Quote**

**Search Manuals**

Enter your information to help us find the right parts manual for your machine.

\* Brand:

\* Model:

\* Serial:

\* Part Number:

SEARCH

**Can't Find Part or  
Manual? Request Help  
by Manufacturer,  
Model & Description**

**Parts Order Form**

Please fill in the following information to help us find the right part for your machine.

MANUFACTURER:

MODEL:

DESCRIPTION:

DATE:

TIME:

PHONE:

EMAIL:

ADDRESS:

CITY:

STATE:

ZIP:

COUNTRY:

SEARCH

Discount-Equipment.com is your online resource for quality parts & equipment.

Florida: **561-964-4949** Outside Florida TOLL FREE: **877-690-3101**

**Need parts?**

Click on this link: <http://www.discount-equipment.com/category/5443-parts/> and choose one of the options to help get the right parts and equipment you are looking for. Please have the machine model and serial number available in order to help us get you the correct parts. If you don't find the part on the website or on one of the online manuals, please fill out the request form and one of our experienced staff members will get back to you with a quote for the right part that your machine needs.

We sell worldwide for the brands: Genie, Terex, JLG, MultiQuip, Mikasa, Essick, Whiteman, Mayco, Toro Stone, Diamond Products, Generac Magnum, Airman, Haulotte, Barreto, Power Blanket, Nifty Lift, Atlas Copco, Chicago Pneumatic, Allmand, Miller Curber, Skyjack, Lull, Skytrak, Tsurumi, Husquvarna Target, Stow, Wacker, Sakai, Mi-T-M, Sullair, Basic, Dynapac, MBW, Weber, Bartell, Bennar Newman, Haulotte, Ditch Runner, Menegotti, Morrison, Contec, Buddy, Crown, Edco, Wyco, Bomag, Laymor, EZ Trench, Bil-Jax, F.S. Curtis, Gehl Pavers, Heli, Honda, ICS/PowerGrit, IHI, Partner, Imer, Clipper, MMD, Koshin, Rice, CH&E, General Equipment, Amida, Coleman, NAC, Gradall, Square Shooter, Kent, Stanley, Tamco, Toku, Hatz, Kohler, Robin, Wisconsin, Northrock, Oztec, Toker TK, Rol-Air, APT, Wylie, Ingersoll Rand / Doosan, Innovatech, Con X, Ammann, Mecalac, Makinex, Smith Surface Prep, Small Line, Wanco, Yanmar

## READ AND UNDERSTAND THE OPERATORS INSTRUCTION MANUAL THOROUGHLY BEFORE ATTEMPTING TO OPERATE THIS EQUIPMENT.



Death or serious injury could occur if this machine is used improperly.



### SAFETY MESSAGES

- Safety Instructions are preceded by a graphic alert symbol of DANGER, WARNING, or CAUTION.



Indicates an imminent hazard which, if not avoided, will result in death or serious injury.



Indicates an imminent hazard which, if not avoided, can result in death or serious injury.



Indicates hazards which, if not avoided, could result in serious injury and or damage to the equipment.

### GASOLINE/PROPANE POWERED EQUIPMENT



- Engine exhaust from this product contains chemicals known to the State of California to cause cancer, birth defects or other reproductive harm.



- Gasoline is extremely flammable and poisonous. It should only be dispensed in well ventilated areas, and with a cool engine.

- Small gasoline engines produce high concentrations of carbon monoxide (CO) example: a 5 HP 4 cycle engine operation in an enclosed 100,000 cu. ft. area with only one change of air per hour is capable of providing deadly concentrations of CO in less than fifteen minutes. Five changes of air in the same area will produce noxious fumes in less than 30 minutes. Gasoline or propane powered equipment should not be used in enclosed or partially enclosed areas. Symptoms of CO poisoning include, headache, nausea, weakness, dizziness, visual problems and loss of consciousness. If symptoms occur - get into fresh air and seek medical attention immediately.

### ELECTRICAL POWERED EQUIPMENT



Extreme care must be taken when operating electric models with water present: Ensure power cord is properly grounded, is attached to a Ground-Fault-Interrupter (GFI) outlet, and is undamaged.

- Check all electrical cables - be sure connections are tight and cable is continuous and in good condition. Be sure cable is correctly rated for both the operating current and voltage of this equipment.
- Improper connection of the equipment-grounding conductor can result in a risk of electric shock. Check with qualified electrician or service person if there is any doubt as to whether the outlet is properly grounded. Adhere to all local codes and ordinances.
- **NOTE:** In the event of a malfunction or breakdown, grounding provides a path of least resistance for the electric current to dissipate. The motor is equipped with a grounded plug and must be connected to an outlet that is properly installed and properly grounded. DO NOT modify the plug provided on the motor. If the plug does not fit the outlet have a qualified electrician install the proper receptacle.
- Switch motor OFF **before** disconnecting power.

- Do not disconnect power by pulling cord. To disconnect, grasp the plug, not the cord.
- Unplug power cord at the machine when not in use and before servicing.

### GENERAL INSTRUCTIONS

- Equipment should only be operated by trained personnel in good physical condition and mental health (not fatigued). The operator and maintenance personnel must be physically able to handle the bulk weight and power of this equipment.
- This is a one person tool. Maintain a safe operating distance to other personnel. It is the **operators' responsibility** to keep other people (workers, pedestrians, bystanders, etc.) away during operation. Block off the work area in all directions with roping, safety netting, etc. for a safe distance. Failure to do so may result in others being injured by flying debris or exposing them to harmful dust and noise.
- This equipment is intended for commercial use only.
- For the operator's safety and the safety of others, always keep all guards in place during operation.
- Never let equipment run unattended.



- Personal Protection Equipment and proper safety attire must be worn when operating this machinery. The operator must wear approved safety equipment appropriate for the job such as hard hat and safety shoes when conditions require. Hearing protection **MUST** be used (operational noise levels of this equipment may exceed 90db). Eye protection **MUST** be worn at all times.



Keep body parts and loose clothing away from moving parts. Failure to do so could result in dismemberment or death.

- Do not modify the machine.
- Stop motor/engine when adjusting or servicing this equipment.
-  Maintain a safe operating distance from flammable materials. Sparks from the cutting-action of this machine can ignite flammable materials or vapors.

### DUST WARNING



Some dust created by power sanding, sawing, grinding, drilling, and other construction activities contains chemicals known to cause cancer, birth defects, or other reproductive harm. Some examples of these chemicals are:

- Lead from lead-based paints, and
  - Crystalline silica from bricks and concrete and other masonry products.
- Your risk of exposure to these chemicals varies depending on how often you do this type of work. To reduce your risk: work in a well ventilated area, use a dust control system, such as an industrial-style vacuum, and wear approved personal safety equipment, such as a dust/particle respirator designed to filter out microscopic particles.

# PARTS LIST MANUAL

## MODEL BB14E

<u>Section</u>	<u>Page Number</u>
Safety Messages / General Instructions . . . . .	2
How To Order Replacement Parts . . . . .	3
Illustration 1 : Main Grouping . . . . .	4,5
Illustration 2 : Arbor Assembly . . . . .	6
Illustration 3 : Rolling Table Assembly . . . . .	6
Illustration 4 : Blade Guard Grouping . . . . .	7
Illustration 5 : Motor Grouping . . . . .	8
Illustration 6 : Optional Stand & Foot Pedal Assembly . . . . .	9
Illustration 7 : Optional Dust Control Vacuum Hood System . . . . .	10
Wiring Diagram . . . . .	11
Limited Equipment Warranty of Sale . . . . .	Back Page

Go to Discount-Equipment.com to order your parts



A Division of Equipment Development Company, Inc.

ILLUSTRATION 1 : MAIN GROUPING

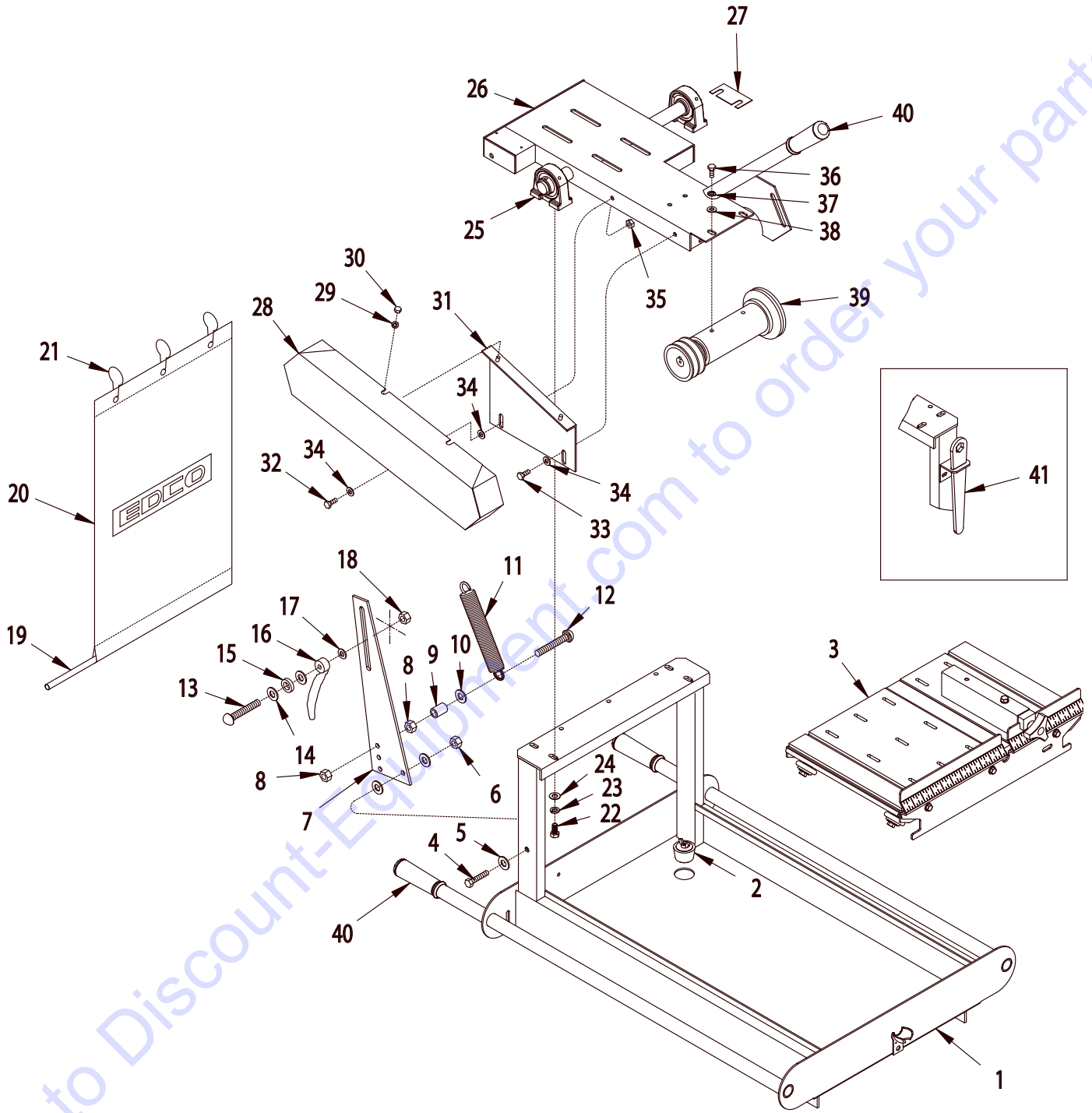

PARTS LISTING - ILLUSTRATION 1 : MAIN GROUPING			
ITEM#	PART#	DESCRIPTION	QTY.
1	40081	PAN WELDMENT	1
2	40378	STOPPER ASSEMBLY 1-1/2"	1
3	40675A	TABLE COMPLETE, ROLLING (REFER TO ILLUS. 3)	1
4	10029	SCREW, CAP 3/8-24 X 1-3/4	1
5	10025	WASHER, FLAT 3/8 SAE	3
6	10004	NUT, LOCK 3/8-24	1
7	40084	PLATE, PIVOT LOCK/LIMIT	1
8	10404	NUT 3/8-16	2
9	10011	SPACER, STEEL 5/8OD X 3/8ID X 3/8THK	1
10	10025	WASHER, FLAT 3/8 SAE	1
11	40032E	SPRING, EXT. 1.125"OD X 7-3/4"L	1
12	10804	BOLT, CARRIAGE 3/8-16 X 1-1/2 F.T.	1
13	10335	BOLT, CARRIAGE 3/8-16 X 2-1/2 F.T.	1
14	10312	WASHER, FLAT 1/2 SAE	2
15	79035	BUSHING, RUBBER 1-1/16"OD X 5/8"ID	1
16	40044	NUT, TAIL HANDLE 3/8-16	1
17	10025	WASHER, FLAT 3/8 SAE	1
18	10404	NUT 3/8-16	1
19	40377	CURTAIN ROD 1/2"DIA. X 13"L	1
20	40375	CURTAIN 15" X 28" W/ LOGO	1
21	40376	HOOK, CURTAIN	3
22	10907	SCREW, CAP 3/8-16 X 3/4	4
23	10811	WASHER, LOCK 3/8	4
24	10025	WASHER, FLAT 3/8 SAE	4
25	50222	BEARING, BALL 1" TPB	2
26	40082	DECK, ARBOR/MOTOR	1
27	40086	SHIM, SWING AXLE BEARING	AS REQ'D.
28	40008	COVER, BELT	1
29	10602	WASHER, FLAT 1/4 SAE	2
30	10861	NUT, KEPS 1/4-20	2
31	40009	BRACKET, BELT COVER	1
32	10806	SCREW, CAP 5/16-18 X 1	1
33	10053	SCREW, CAP 5/16-18 X 3/4	1
34	10213	WASHER, FLAT 5/16 SAE	3
35	10807	NUT, LOCK 5/16-18	2
36	10048	SCREW, CAP 5/16-24 X 3/4	4
37	10801	WASHER, LOCK 5/16	4
38	10213	WASHER, FLAT 5/16 SAE	4
39	----	ARBOR ASSY. W/ SHEAVE (REFER TO ILLUS. 2)	1
40	10608	GRIP, HAND 1" MODEL AT	3
41	53021	WRENCH, ARBOR, 3/4" BOX END	1

**ILLUSTRATION 2 : ARBOR ASSEMBLY**

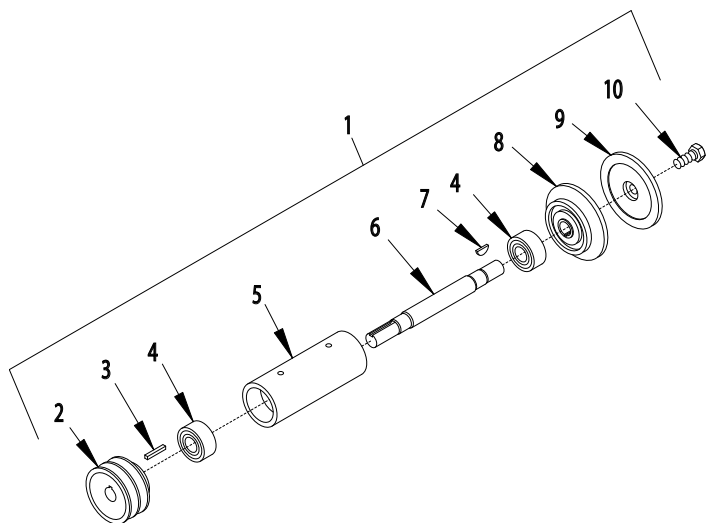

ITEM #	PART #	DESCRIPTION	QTY.
1*	40056A 40056	ARBOR ASSY. W/ 2.75" 2GR.3V SHEAVE ARBOR ASSY. W/ 3" 2GR.A SHEAVE	1 1
2*	40694 40005	SHEAVE 2.75"OD X 2GR.3V X 3/4"BORE SHEAVE 3"OD X 2GR.A X 3/4"BORE	1 1
3	10170	KEY 3/16 SQ X 1-3/4	1
4	40018	BEARING, RADIAL BALL 20X47X20.6MM	2
5	40020	ARBOR HOUSING	1
6	40021	ARBOR SHAFT 8-7/8"L	1
7	40036	KEY, WOODRUFF 1/8 X 3/8 (#403)	1
8	40022	ARBOR BACKING PLATE 4"	1
9	40023	ARBOR BLADE CAP 4"	1
10	10321	SCREW, CAP 1/2-20 X 1-1/4	1

\*NOTE: STARTING SERIAL # 110810241 USE PART # 40056A & 40694  
PRIOR TO SERIAL # 110810241 USE PART # 40056 & 40005

**ILLUSTRATION 3 : ROLLING TABLE ASSEMBLY**

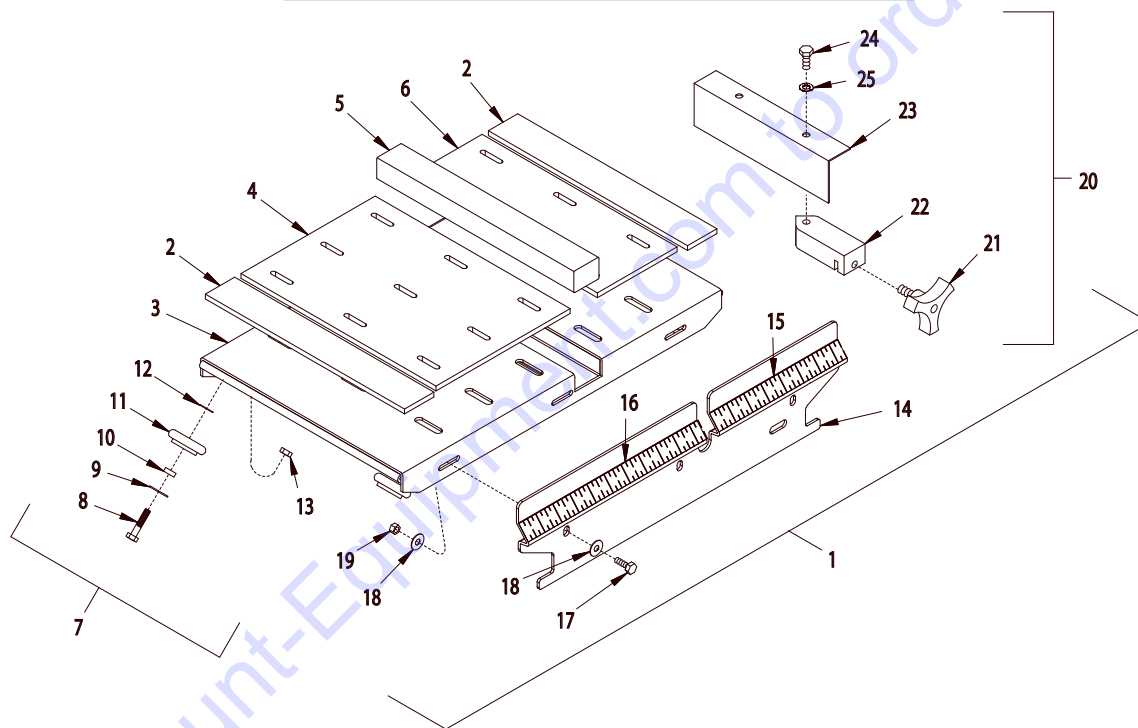

ITEM#	PART#	DESCRIPTION	QTY.	ITEM#	PART#	DESCRIPTION	QTY.
1	40675A	TABLE COMPLETE, ROLLING (ITEMS 2-20)	1	14	40603	TABLE FRONT PANEL, ROLL	1
2	40679	RUBBER PAD 11-5/8 X 1-3/4 X 1/4	2	15	40424	RULE, ADHESIVE BACKED 1-7, L-R	1
3	40675	TABLE, ROLLING	1	16	40423	RULE, ADHESIVE BACKED 1-13, R-L	1
4	40676	RUBBER PAD 11-5/8 X 8	1	17	10018	SCREW, CAP 1/4-20X3/4	3
5	40678	WOODEN CUT BLOCK	1	18	10602	WASHER, FLAT 1/4	6
6	40677	RUBBER PAD 11-5/8 X 4-3/4	1	19	10861	NUT, KEPS 1/4-20	3
7	40605K	WHEEL KIT, ROLL TABLE (INCLUDES ITEMS 8 THRU 13)	4	20	40604A	CUT GUIDE ASSEMBLY COMPLETE (INCLUDES ITEMS 21-25)	1
8	10606	SCREW, CAP 5/16-18 X 1-1/4	4	21	40425	KNOB, 3 PRONG W/ 3/8-16X5/8 STUD	1
9	40667	WASHER, FLAT .328ID X .875OD X .060	4	22	42015	BLOCK, CUT GUIDE, MASONRY SAW	1
10	40668	SPACER, STEEL 5/8OD X .328ID X .180	4	23	40604	BRACKET, CUT GUIDE	1
11	40605A	WHEEL W/ BEARING, ROLL TABLE	4	24	10053	SCREW, CAP 5/16-18X3/4	1
12	10213	WASHER, FLAT 5/16	4	25	10801	WASHER, LOCK 5/16	1
13	10807	NUT, LOCK 5/16-18	4				

**ILLUSTRATION 4 : BLADE GUARD GROUPING**

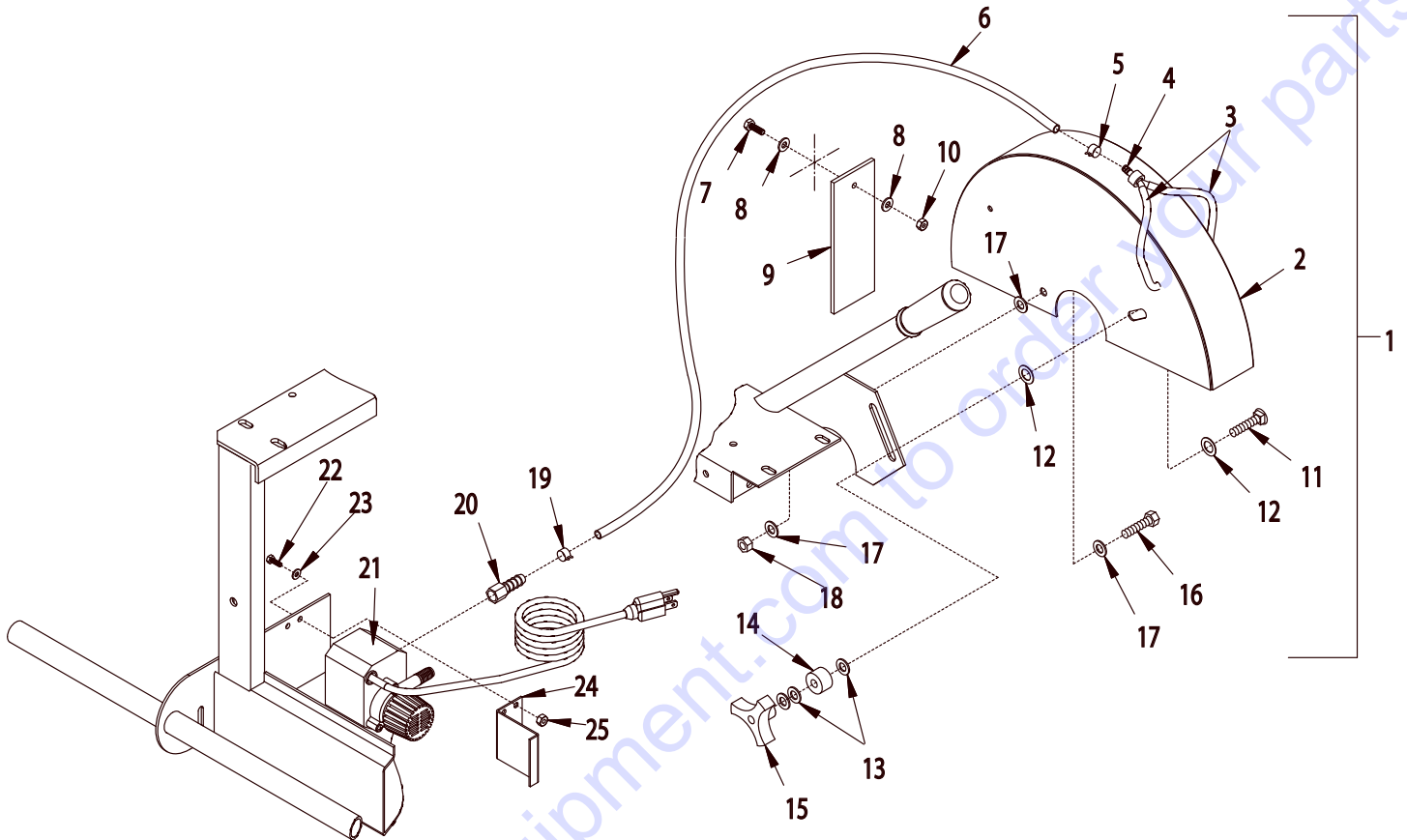

ITEM#	PART#	DESCRIPTION	QTY.	ITEM#	PART#	DESCRIPTION	QTY.
1	40083A	GUARD COMPLETE, BLADE 14" (INCLUDES ITEMS 2 THRU 10)	1	13	10025	WASHER, FLAT 3/8 SAE	3
2	40083	GUARD, BLADE 14"	1	14	10034	BUSHING, RUBBER 1"OD X 3/8ID X 5/8T	1
3	40654	HOSE 1/4"ID X 6"L	2	15	80011	KNOB, 3-PRONG W/ 3/8-16 THD.	1
4	99323	BARBED FITTING, "Y" 1/4"HOSE	1	16	10021	SCREW, CAP 3/8-24 X 1	1
5	10763	CLAMP, HOSE SPRING-TYPE 7/16" RED	1	17	10025	WASHER, FLAT 3/8 SAE	3
6	40087	HOSE 1/4"ID X 48"L	1	18	10004	NUT, LOCK 3/8-24	1
7	10018	SCREW, CAP 1/4-20 X 3/4	1	19	10763	CLAMP, HOSE SPRING-TYPE 7/16" RED	1
8	10602	WASHER, FLAT 1/4 SAE	2	20	40415	BARB, 1/4HOSE X 1/4FPT	1
9	40012	FLAP, SPLASH 2-1/2 X 7	1	21	40017	PUMP, WATER, 115VAC, SUBMERSIBLE	1
10	10015	NUT, LOCK 1/4-20	1	22	10834	SCREW, CAP 1/4-20 X 1/2	2
11	10804	BOLT, CARRIAGE 3/8-16 X 1-1/2 F.T.	1	23	10602	WASHER, FLAT 1/4 SAE	2
12	10040	WASHER, GARRET 17/32 X 1 X .054	2	24	40085	RETAINER, WATER PUMP	1
				25	10861	NUT, KEPS 1/4-20	2



**ILLUSTRATION 5 : MOTOR GROUPING**

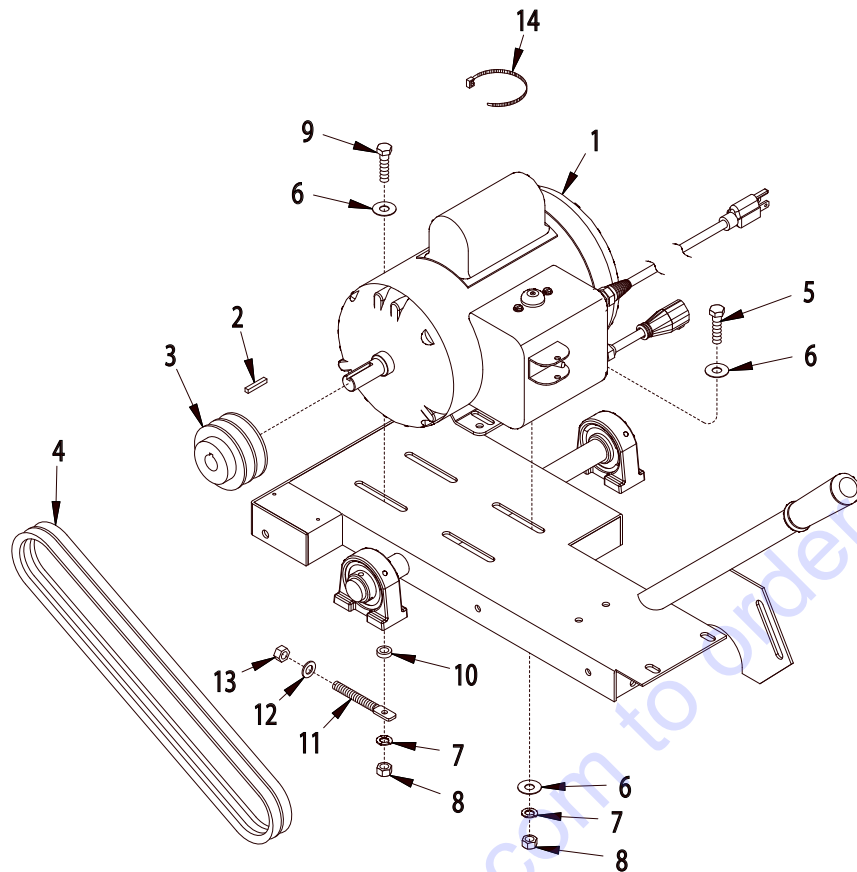

ITEM #	PART #	DESCRIPTION	QTY.
1	<b>16061</b>	<b>MOTOR, BALDOR 1.5HP-1P-60HZ-115/230V-3450RPM BALDOR SPEC. 35V801R760G1</b>	1
	40051	REPLACEMENT PARTS: CAPACITOR, START, BALDOR EC1645A06 645-774MFD 125V	1
	16164	CAPACITOR, RUN, BALDOR OC3040F09SP 40MFD 370V	1
	16163	RESET BUTTON, BALDOR TPCRT40CA	1
	16510	SWITCH, TOGGLE DPST 20A SPAD	1
2	----	KEY 3/16 SQ. (INCLUDED W/ MOTOR)	1
3*	40694	SHEAVE 2.75"OD X 2GR.3V X 3/4"BORE	1
	40005	SHEAVE 3"OD X 2GR.A X 3/4"BORE	1
4*	10258	BELT 3VX-375	2
	50018	BELT AX-38	2
5	10806	SCREW, CAP 5/16-18 X 1	3
6	10213	WASHER, FLAT 5/16 SAE ZINC	7
7	10801	WASHER, LOCK 5/16 ZINC	4
8	10054	NUT, HEX 5/16-18 ZINC	4
9	10606	SCREW, CAP 5/16-18 X 1-1/4	1
10	10113	SPACER, STEEL 9/16OD X 3/8ID X 7/32	1
11	40088	TENSIONER, MOTOR, BB14 ELEC	1
12	10025	WASHER, FLAT 3/8 SAE ZINC	1
13	10404	NUT, HEX 3/8-16 ZINC	1
14	10982	TIE, CABLE, BLACK NYLON 11-1/4"	2
<p>*NOTE: STARTING SERIAL # 110810241 USE PART # 40694 &amp; 10258. PRIOR TO SERIAL # 110810241 USE PART # 40005 &amp; 50018.</p>			

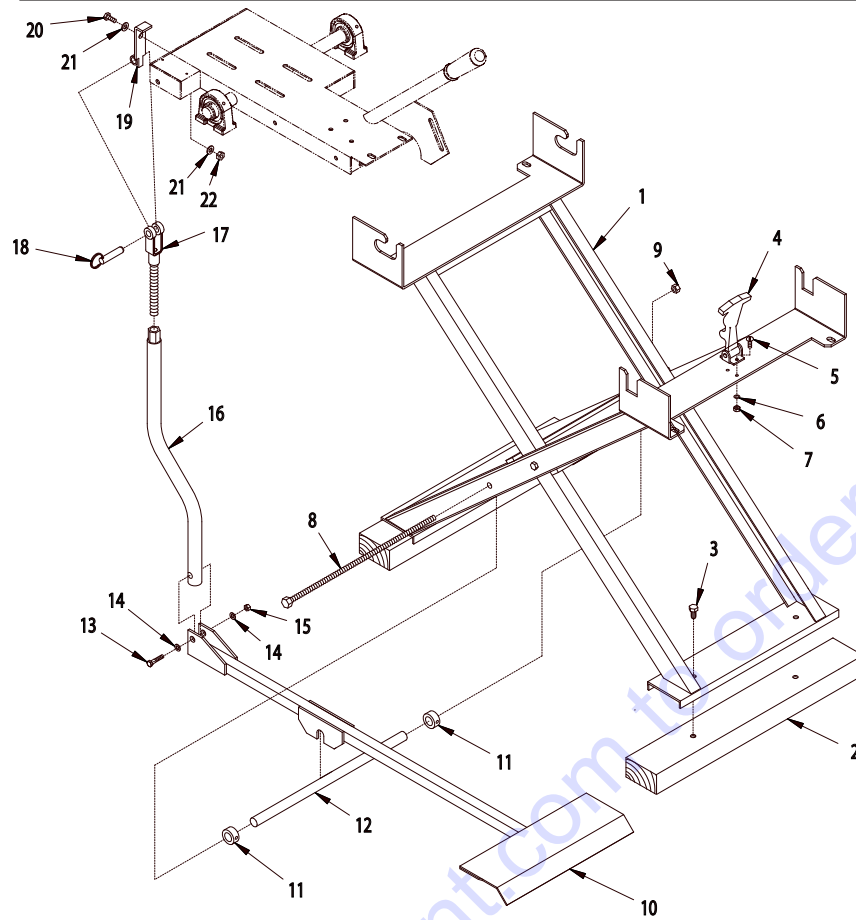
**ILLUSTRATION 6 : OPTIONAL STAND & FOOT PEDAL ASSEMBLY**

FOLDING STAND - PART #40631 (INCLUDES ITEMS 1-7)

FOOT PEDAL KIT - PART #40632 (INCLUDES ITEMS 8-22)

ITEM #	PART #	DESCRIPTION	QTY.
1	40631W	STAND ONLY	1
2	21801	SKID BOARD 2x4x24"L	2
3	10367	BOLT, LAG 3/8x1	4
4	52002	LATCH, FLEXIBLE DRAW w/ T-HANDLE	1
5	10830	SCREW, MACHINE 10-32x1/2	2
6	10831	WASHER, LOCK, INT. TOOTH #10	2
7	10832	NUT 10-32	2
8	40383	BOLT, ALLTHREAD ROD 1/2-13x17-1/2	1
9	10407	NUT, LOCK 1/2-13	1
10	40633	FOOT PEDAL	1
11	10428	COLLAR, LOCKING 3/4" I.D.	2
12	40634	FOOT PEDAL PIVOT TUBE	1
13	10029	SCREW, CAP 3/8-24x1-3/4	1
14	10025	WASHER, FLAT 3/8	2
15	10004	NUT, LOCK 3/8-24	1
16	40635	FOOT PEDAL LINKAGE	1
17	41019	LINKAGE, CLEVIS	1
18	10125	PIN, DETENT RING 1/2x1-1/2	1
19	40688	MOUNT, FOOT PEDAL LINKAGE	1
20	10806	SCREW, CAP 5/16-18 X 1	1
21	10213	WASHER, FLAT 5/16 SAE	2
22	10807	NUT, LOCK 5/16-18	1

**ILLUSTRATION 7 : OPTIONAL DUST CONTROL  
VACUUM HOOD SYSTEM**

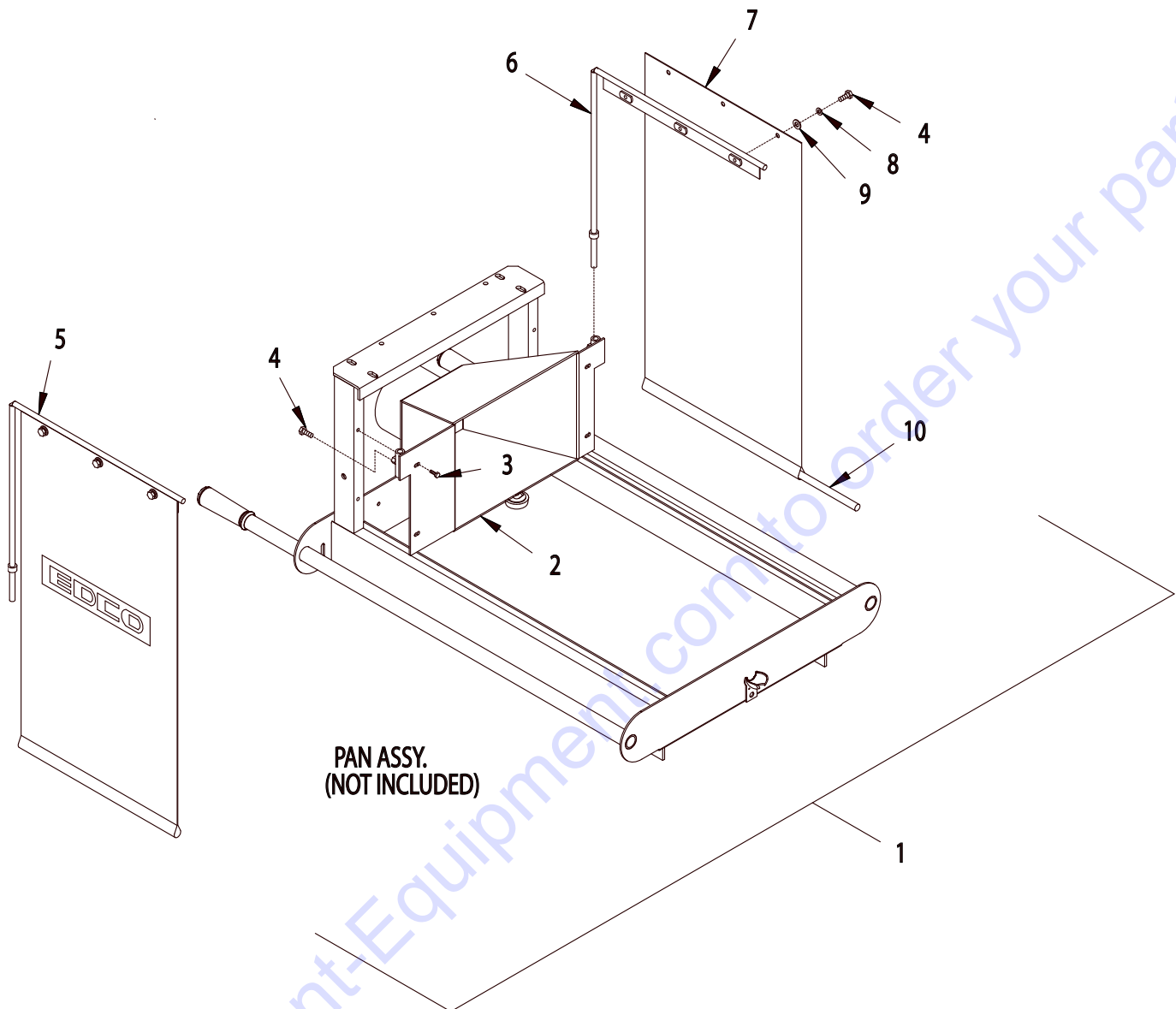

ITEM#	PART#	DESCRIPTION	QTY.
1	40075	VACUUM HOOD SYSTEM COMPLETE (INCLUDES ITEMS 2-10)	
2	40076	VACUUM HOOD	1
3	10846	SCREW, CAP STSHW 1/4-20x1/2	4
4	10018	SCREW, CAP 1/4-20x3/4	8
5	40078	CURTAIN ROD, VAC SYSTEM, L.H.	1
6	40077	CURTAIN ROD, VAC SYSTEM, R.H.	1
7	40375	CURTAIN 15"x28" w/ LOGO	2
8	10038	WASHER, LOCK 1/4	6
9	10602	WASHER, FLAT 1/4	6
10	40377	CURTAIN ROD 1/2"DIA. X 13"L	2

CD1023

**WIRING DIAGRAM**

CD1023

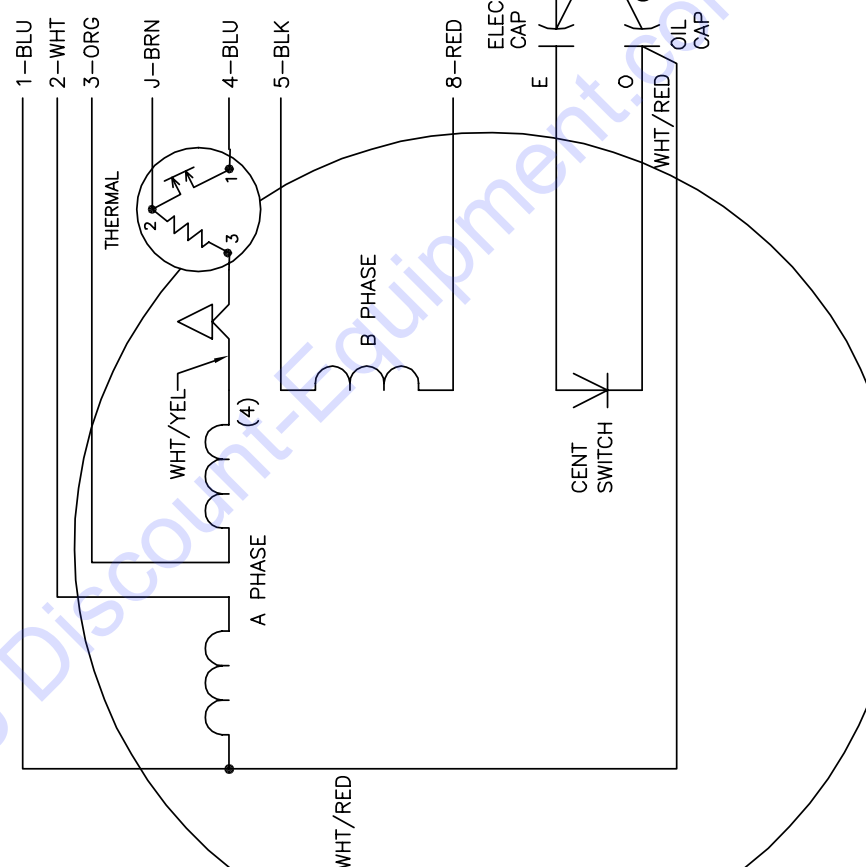
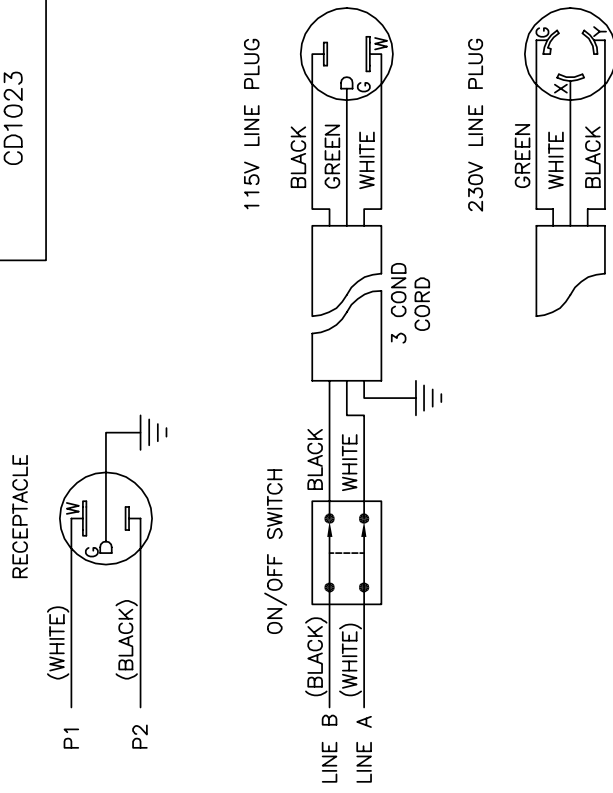

LINE A	LINE B	JOIN	JOIN	JOIN
HIGH STD	1,P1	4	2,3,5,P2	J
HIGH OPP	1,P1	4	2,3,8,P2	J
LOW STD	1,3,P1	4	2,5,J,P2	C,8
LOW OPP	1,3,P1	4	2,8,J,P2	C,5

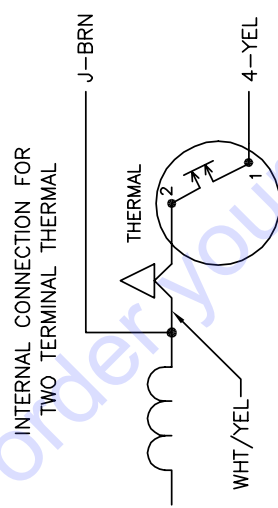

- NOTES:
1. STANDARD ROTATION IS CCW FACING END OPPOSITE SHAFT EXTENSION.
  2. MULTIPLE CAPACITORS ARE CONNECTED IN PARALLEL UNLESS OTHERWISE SPECIFIED.
  3. LEAD COLORS ARE OPTIONAL. LEADS MUST ALWAYS BE NUMBERED AS SHOWN.

**BALDOR ELECTRIC Co.**

REV. DESC:	ADD OPTIONAL LEAD COLORS
REV. LTR:	B BY: JLP REVISED: 10:01:18 08/27/2001 TDR: 248206
FILE:	AAA00018033 REF: CD1023
MTL:	-

TYPE LC, DV, REV, THERMAL, 8 LD, LINE SW, CORD, PLUG, 115V RECEPT

# PARTS FINDER

**Search Website  
by Part Number**



**Search Manual  
Library For Parts  
Manual & Lookup Part  
Numbers – Purchase  
or Request Quote**

**Search Manuals**

Enter your information to help us find the right parts manual for your machine.

\* Brand:

\* Model:

\* Serial:

\* Part Number:

SEARCH

**Can't Find Part or  
Manual? Request Help  
by Manufacturer,  
Model & Description**

**Parts Order Form**

Please fill in the following information to help us find the right part for your machine.

Manufacturer:	<input type="text"/>
Model:	<input type="text"/>
Description:	<input type="text"/>
Part Number:	<input type="text"/>
Quantity:	<input type="text"/>
Notes:	<input type="text"/>

Submit

Discount-Equipment.com is your online resource for quality parts & equipment.

Florida: **561-964-4949** Outside Florida TOLL FREE: **877-690-3101**

**Need parts?**

Click on this link: <http://www.discount-equipment.com/category/5443-parts/> and choose one of the options to help get the right parts and equipment you are looking for. Please have the machine model and serial number available in order to help us get you the correct parts. If you don't find the part on the website or on one of the online manuals, please fill out the request form and one of our experienced staff members will get back to you with a quote for the right part that your machine needs.

We sell worldwide for the brands: Genie, Terex, JLG, MultiQuip, Mikasa, Essick, Whiteman, Mayco, Toro Stone, Diamond Products, Generac Magnum, Airman, Haulotte, Barreto, Power Blanket, Nifty Lift, Atlas Copco, Chicago Pneumatic, Allmand, Miller Curber, Skyjack, Lull, Skytrak, Tsurumi, Husquvarna Target, Stow, Wacker, Sakai, Mi-T-M, Sullair, Basic, Dynapac, MBW, Weber, Bartell, Bennar Newman, Haulotte, Ditch Runner, Menegotti, Morrison, Contec, Buddy, Crown, Edco, Wyco, Bomag, Laymor, EZ Trench, Bil-Jax, F.S. Curtis, Gehl Pavers, Heli, Honda, ICS/PowerGrit, IHI, Partner, Imer, Clipper, MMD, Koshin, Rice, CH&E, General Equipment, Amida, Coleman, NAC, Gradall, Square Shooter, Kent, Stanley, Tamco, Toku, Hatz, Kohler, Robin, Wisconsin, Northrock, Oztec, Toker TK, Rol-Air, APT, Wylie, Ingersoll Rand / Doosan, Innovatech, Con X, Ammann, Mecalac, Makinex, Smith Surface Prep, Small Line, Wanco, Yanmar