

4" HYDRAULIC SUBMERSIBLE SLUDGE PUMP

MODEL S4THL (Aluminum Body)

MODEL S4THLDI (Ductile Iron Body)

4" (100 mm) Discharge

The S4THL has proven to be an excellent sludge pump. Primary uses for this pump are: oil refinery wastes, sewage digester cleanout, water waste sludges and desilting applications using divers. This versatile pump offers solids handling and high head capabilities.



FEATURES

- Fully Recessed Vortex Impeller
(Will Pass 3 1/2" Semi-Solids)
- Lightweight Aluminum and Durable
Ductile Iron models are standard
- Stainless Steel version available
- Variable Speed Drive
- Wide Range of Performance
- Oil Lubricated Seals (Can Run Dry)
- Can be Bolted Directly Into a Pipeline or
Fitted with a Suction Hose for Vacuuming
Underwater
- Safe Hydraulic Drive can be used where
Electric Power is Hazardous or Impractical
- Operates with Our HT50 and HT60 Power Units
or Other Hydraulic Power Sources with flows
of 15 - 30 GPM

SPECIFICATIONS

WEIGHT: (Aluminum).....	179 lbs. (75kg)
(Ductile Iron).....	324 lbs. (147 kg)
HEIGHT:.....	34 1/2" (88 cm)
DIAMETER(@ widest point):.....	25 1/2" (65 cm)
DISCHARGE:.....	4", 125# ASA Flange
INLET FLANGE:.....	4", 125# ASA
SOLIDS HANDLING:.....	3 1/2" (9 cm)
HOSE PORTS:.....	1" SAE
PUMP BODY: (S4THL).....	Heat Treated Aluminum
(S4THLDI).....	Ductile Iron
IMPELLER:.....	Ductile Iron
WEAR RING and WEAR PLATE.....	Stainless Steel
SHAFT:.....	Stainless Steel
SHAFT SEAL:.....	Carbon/Ceramic (Std)
	Silicon Carbide (Optional)
ELASTOMERS:.....	Buna N (Std)
HYDRAULIC OIL:.....	214-320 s.s.u. @ 100°F (64°C)
INPUT FLOW:.....	Max 30 GPM (114 LPM)
OPERATING PRESSURE:.....	Max 3000 PSI (204 Bar)
POWER SOURCE:.....	Any Open Center Hydraulic System

C0701

Specifications subject to change without notice.

Model S4THL Overall Dimensions

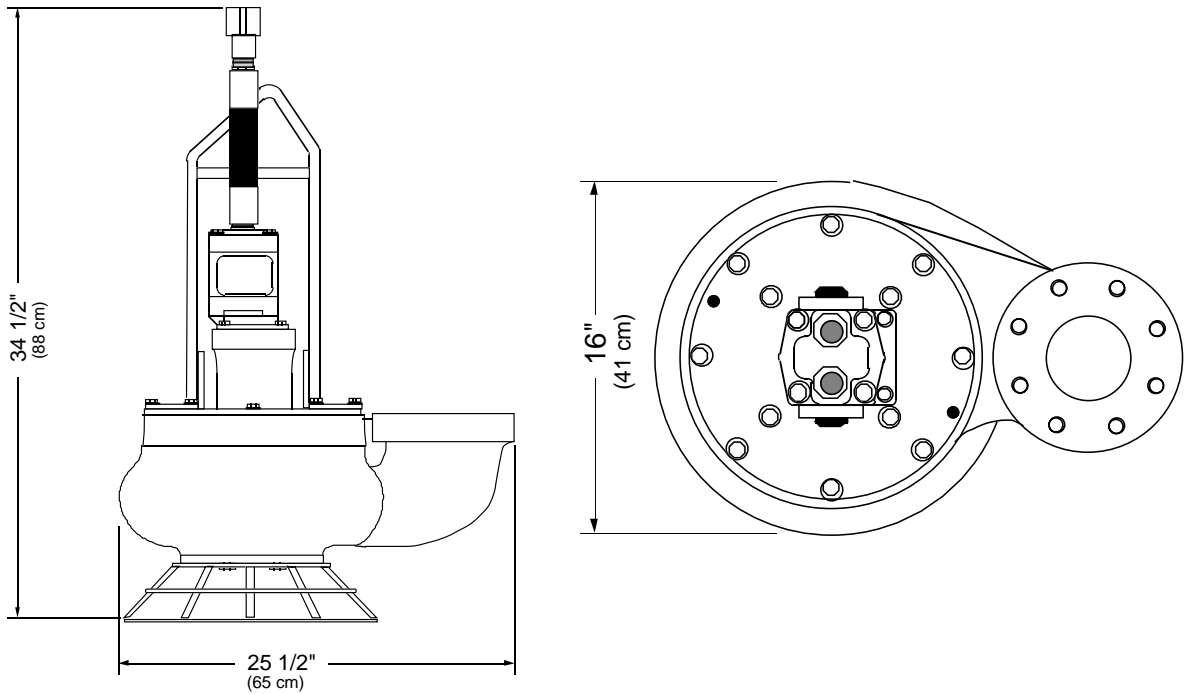

S4THL Typical Performance

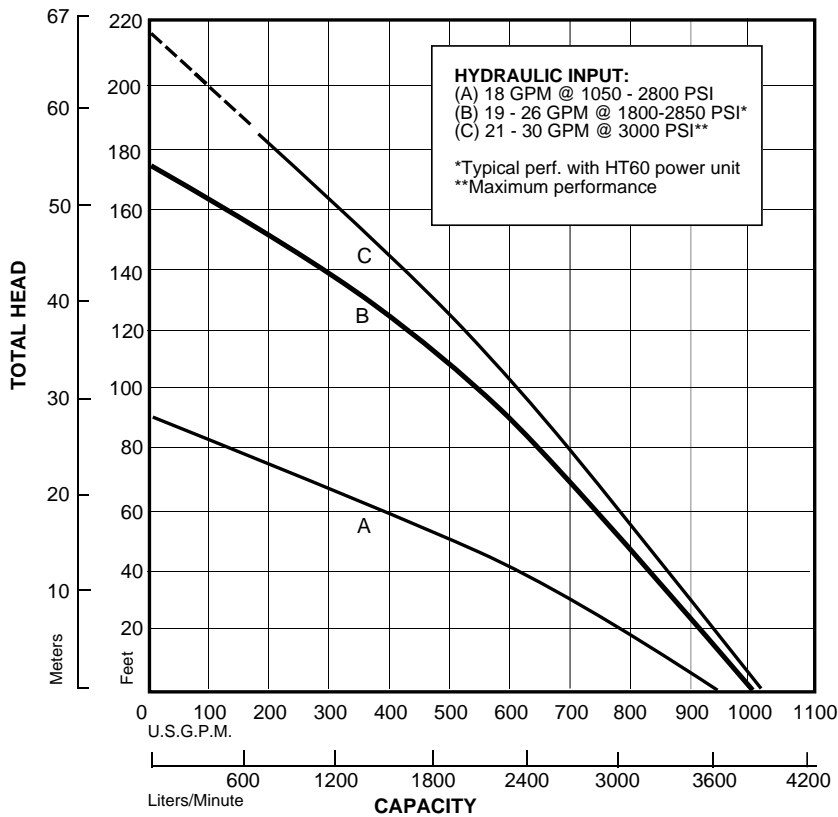

Since we are constantly working to improve our products, specifications are subject to change without notice.



P.O. Box 537, Mt. Holly, NJ 08060, USA
 Website: www.hydra-tech.com

Phone: 609-267-5393 Fax: 609-261-8070
 E-Mail: htpump@hydra-tech.com