

REVISED STARTING
SERIAL # 130910012

PARTS LIST MANUAL

MODEL TS-8 TILESHARK



8" MANUAL FLOOR STRIPPERS

SKU #	MODEL #	POWER OPTION
94400	TS8-.75L	LEESON ELECTRIC MOTOR .75HP 1PH 60Hz 115/230V
94500	TS8-.75L/50	LEESON ELECTRIC MOTOR .75HP 1PH 50Hz 110/220V



A Division of Equipment Development Company, Inc.



Printed in USA

JWA ©2013

PARTS FINDER

**Search Website
by Part Number**



**Search Manual
Library For Parts
Manual & Lookup Part
Numbers – Purchase
or Request Quote**

Search Manuals

Enter your information to help us find the right parts manual for your machine.

* Brand:

* Model:

* Serial:

* Part Number:

SEARCH

**Can't Find Part or
Manual? Request Help
by Manufacturer,
Model & Description**

Parts Order Form

Please fill in the following information to help us find the right part for your machine.

MANUFACTURER:

MODEL:

DESCRIPTION:

DATE:

TIME:

PHONE:

EMAIL:

ADDRESS:

CITY:

STATE:

ZIP:

SEARCH

Discount-Equipment.com is your online resource for quality parts & equipment.

Florida: **561-964-4949** Outside Florida TOLL FREE: **877-690-3101**

Need parts?

Click on this link: <http://www.discount-equipment.com/category/5443-parts/> and choose one of the options to help get the right parts and equipment you are looking for. Please have the machine model and serial number available in order to help us get you the correct parts. If you don't find the part on the website or on one of the online manuals, please fill out the request form and one of our experienced staff members will get back to you with a quote for the right part that your machine needs.

We sell worldwide for the brands: Genie, Terex, JLG, MultiQuip, Mikasa, Essick, Whiteman, Mayco, Toro Stone, Diamond Products, Generac Magnum, Airman, Haulotte, Barreto, Power Blanket, Nifty Lift, Atlas Copco, Chicago Pneumatic, Allmand, Miller Curber, Skyjack, Lull, Skytrak, Tsurumi, Husquvarna Target, Stow, Wacker, Sakai, Mi-T-M, Sullair, Basic, Dynapac, MBW, Weber, Bartell, Bennar Newman, Haulotte, Ditch Runner, Menegotti, Morrison, Contec, Buddy, Crown, Edco, Wyco, Bomag, Laymor, EZ Trench, Bil-Jax, F.S. Curtis, Gehl Pavers, Heli, Honda, ICS/PowerGrit, IHI, Partner, Imer, Clipper, MMD, Koshin, Rice, CH&E, General Equipment, Amida, Coleman, NAC, Gradall, Square Shooter, Kent, Stanley, Tamco, Toku, Hatz, Kohler, Robin, Wisconsin, Northrock, Oztec, Toker TK, Rol-Air, APT, Wylie, Ingersoll Rand / Doosan, Innovatech, Con X, Ammann, Mecalac, Makinex, Smith Surface Prep, Small Line, Wanco, Yanmar

READ AND UNDERSTAND THE OPERATORS INSTRUCTION MANUAL THOROUGHLY BEFORE ATTEMPTING TO OPERATE THIS EQUIPMENT.



Death or serious injury could occur if this machine is used improperly.



SAFETY MESSAGES

- Safety Instructions are preceded by a graphic alert symbol of DANGER, WARNING, or CAUTION.



Indicates an imminent hazard which, if not avoided, will result in death or serious injury.



Indicates an imminent hazard which, if not avoided, can result in death or serious injury.



Indicates hazards which, if not avoided, could result in serious injury and or damage to the equipment.

GASOLINE/PROPANE POWERED EQUIPMENT



• Engine exhaust from this product contains chemicals known to the State of California to cause cancer, birth defects or other reproductive harm.



Gasoline is extremely flammable and poisonous. It should only be dispensed in well ventilated areas, and with a cool engine.

- Small gasoline engines produce high concentrations of carbon monoxide (CO) example: a 5 HP 4 cycle engine operation in an enclosed 100,000 cu. ft. area with only one change of air per hour is capable of providing deadly concentrations of CO in less than fifteen minutes. Five changes of air in the same area will produce noxious fumes in less than 30 minutes. Gasoline or propane powered equipment should not be used in enclosed or partially enclosed areas. Symptoms of CO poisoning include, headache, nausea, weakness, dizziness, visual problems and loss of consciousness. If symptoms occur - get into fresh air and seek medical attention immediately.

ELECTRICAL POWERED EQUIPMENT



Extreme care must be taken when operating electric models with water present: Ensure power cord is properly grounded, is attached to a Ground-Fault-Interrupter (GFI) outlet, and is undamaged.

- Check all electrical cables - be sure connections are tight and cable is continuous and in good condition. Be sure cable is correctly rated for both the operating current and voltage of this equipment.
- Improper connection of the equipment-grounding conductor can result in a risk of electric shock. Check with qualified electrician or service person if there is any doubt as to whether the outlet is properly grounded. Adhere to all local codes and ordinances.
- **NOTE:** In the event of a malfunction or breakdown, grounding provides a path of least resistance for the electric current to dissipate. The motor is equipped with a grounded plug and must be connected to an outlet that is properly installed and properly grounded. DO NOT modify the plug provided on the motor. If the plug does not fit the outlet have a qualified electrician install the proper receptacle.
- Switch motor OFF **before** disconnecting power.

- Do not disconnect power by pulling cord. To disconnect, grasp the plug, not the cord.
- Unplug power cord at the machine when not in use and before servicing.

GENERAL INSTRUCTIONS

- Equipment should only be operated by trained personnel in good physical condition and mental health (not fatigued). The operator and maintenance personnel must be physically able to handle the bulk weight and power of this equipment.
- This is a one person tool. Maintain a **safe operating distance** to other personnel. It is the **operators' responsibility** to keep other people (workers, pedestrians, bystanders, etc.) away during operation. Block off the work area in all directions with roping, safety netting, etc. for a **safe distance**. Failure to do so may result in others being injured by flying debris or exposing them to harmful dust and noise.
- This equipment is intended for commercial use only.
- For the operator's safety and the safety of others, always keep all guards in place during operation.
- Never let equipment run unattended.



- Personal Protection Equipment and proper safety attire must be worn when operating this machinery. The operator must wear approved safety equipment appropriate for the job such as hard hat and safety shoes when conditions require. Hearing protection **MUST** be used (operational noise levels of this equipment may exceed 85 dBA). Eye protection **MUST** be worn at all times.



Keep body parts and loose clothing away from moving parts. Failure to do so could result in dismemberment or death.

- Do not modify the machine.
 - Stop motor/engine when adjusting or servicing this equipment.
- Maintain a safe operating distance from flammable materials. Sparks from the cutting-action of this machine can ignite flammable materials or vapors.

DUST WARNING



Some dust created by power sanding, sawing, grinding, drilling, and other construction activities contains chemicals known to cause cancer, birth defects, or other reproductive harm. Some examples of these chemicals are:

- Lead from lead-based paints, and
 - Crystalline silica from bricks and concrete and other masonry products.
- Your risk of exposure to these chemicals varies depending on how often you do this type of work. To reduce your risk: work in a well ventilated area, use a dust control system, such as an industrial-style vacuum, and wear approved personal safety equipment, such as a dust/particle respirator designed to filter out microscopic particles.

PARTS LIST MANUAL

MODEL TS-8 TILESHARK

8" MANUAL FLOOR STRIPPER

TABLE OF CONTENTS

<u>Section</u>	<u>Page Numbers</u>
Safety Messages and General Instructions	2
How To Order Replacement Parts	3
Illustration 1: Main Grouping	4, 5
Illustration 2: Wheel, Fork and Handle Lower Leg Grouping	6, 7
Illustration 3: Handle Grouping	8, 9
Illustration 4: Motor Grouping	10, 11
Wiring Diagram for Switch	12
Wiring Diagrams for Motor	13
Decal Sheet P/N 92217	14
Decal Sheet P/N 92208	15
Limited Equipment Warranty of Sale - Terms & Conditions	16 (Back Page)



A Division of Equipment Development Company, Inc.

ILLUSTRATION 1: MAIN GROUPING

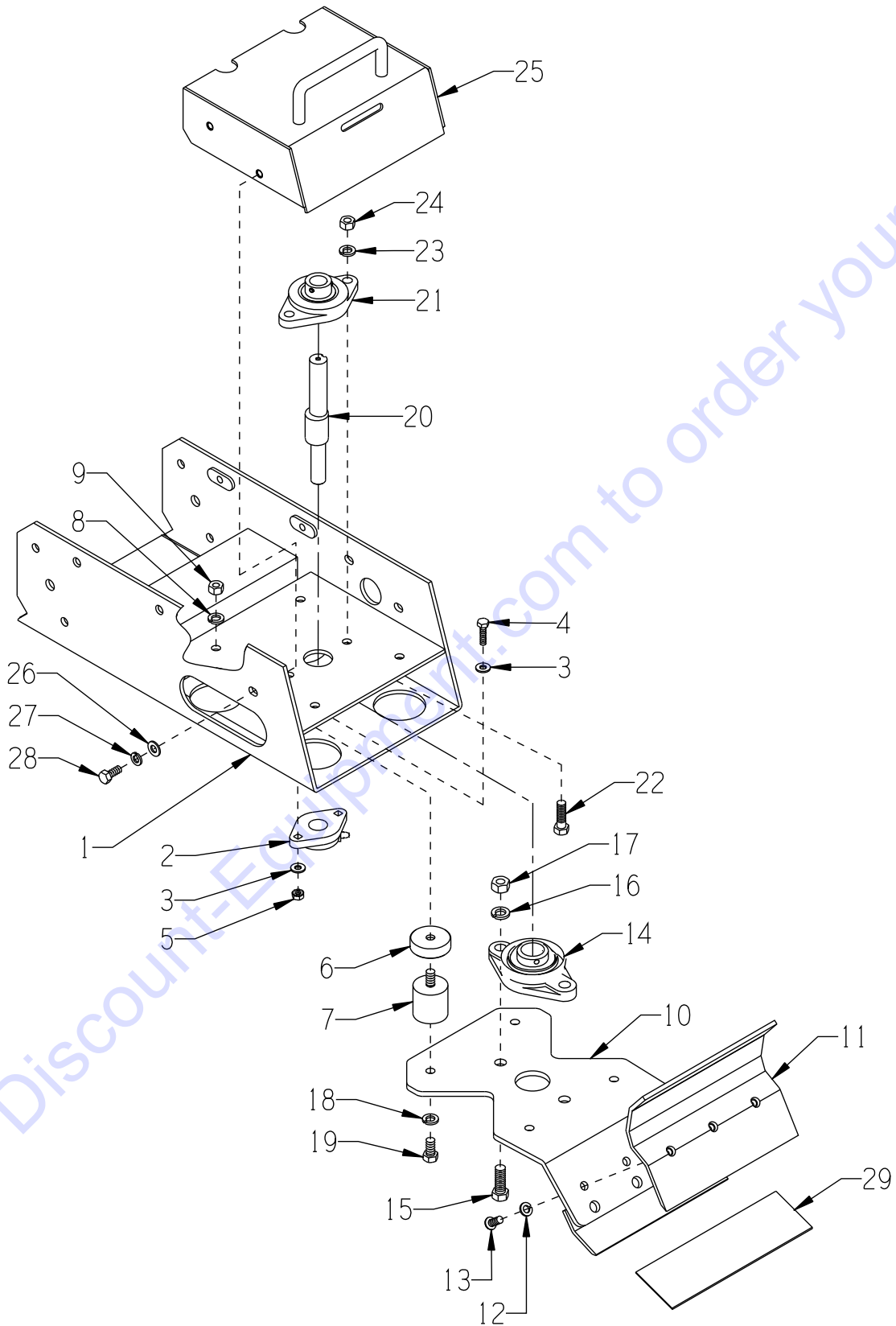

Go to Discount-Edco.com to order your parts

**PARTS LISTING
ILLUSTRATION 1 : MAIN GROUPING**

ITEM #	PART #	DESCRIPTION	QTY.
1	28101	MAIN FRAME, TILE SHARK	1
2	80009G	BEARING, BALL 5/8" 2-HOLE (W/ G.F.)	1
3	10602	WASHER, FLAT 1/4 SAE ZINC	2
4	10031	SCREW, CAP 1/4-20 X 1	2
5	10861	NUT, KEPS LOCK 1/4-20 ZINC	2
6	28148	ISOLATOR CUP, TILE SHARK	4
7	28115	MOUNT, FLEX-BOLT SANDWICH 3/8-16	4
8	10811	WASHER, LOCK 3/8 ZINC	4
9	10404	NUT, HEX 3/8-16 ZINC	4
10	28145	STRIKER PLATE, TILE SHARK	1
11	28146	RETAINER, SCRAPER BLADE	1
12	10801	WASHER, LOCK 5/16 ZINC	3
13	10627	SCREW, SKT. BUTTON HD. 5/16-18 X 3/4	3
14	62022	BEARING, BALL 1" 2-HOLE FLANGE	1
15	10003	SCREW, CAP 7/16-20 X 1-1/4 ZINC	2
16	10450	WASHER, LOCK 7/16 ZINC	2
17	10481	NUT, HEX 7/16-20 ZINC	2
18	10811	WASHER, LOCK 3/8 ZINC	4
19	10907	SCREW, CAP 3/8-16 X 3/4	4
20	28116	CAM SHAFT, STRIKER PLATE, TS-8	1
21	50049	BEARING, BALL 3/4" 2-HOLE FLANGE	1
22	10309	SCREW, CAP 3/8-24 X 1-1/4 ZINC	2
23	10811	WASHER, LOCK 3/8 ZINC	2
24	10014	NUT, HEX 3/8-24 ZINC	2
25	28137	HOOD, TILE SHARK	1
26	10213	WASHER, FLAT 5/16 SAE ZINC	4
27	10801	WASHER, LOCK 5/16 ZINC	4
28	10053	SCREW, CAP 5/16-18 X 3/4	4
29*		SCRAPER & SLICER BLADES (NOT INCLUDED)	*
	28040	8" RIGID (PACK OF 5)	
	28050	8" SLICER FOR LINOLEUM & CARPET (PACK OF 5)	
	28060	12" FOAM RUBBER BACKING (PACK OF 5)	

* REFER TO EQUIPMENT CATALOG & PRICE LIST FOR BLADES THAT ARE AVAILABLE. BLADES ARE SOLD IN PACKS OF 5.



A Division of Equipment Development Company, Inc.

Printed in USA

JWA ©2013

Page 5

ILLUSTRATION 2: WHEEL, FORK AND HANDLE LOWER LEG GROUPING

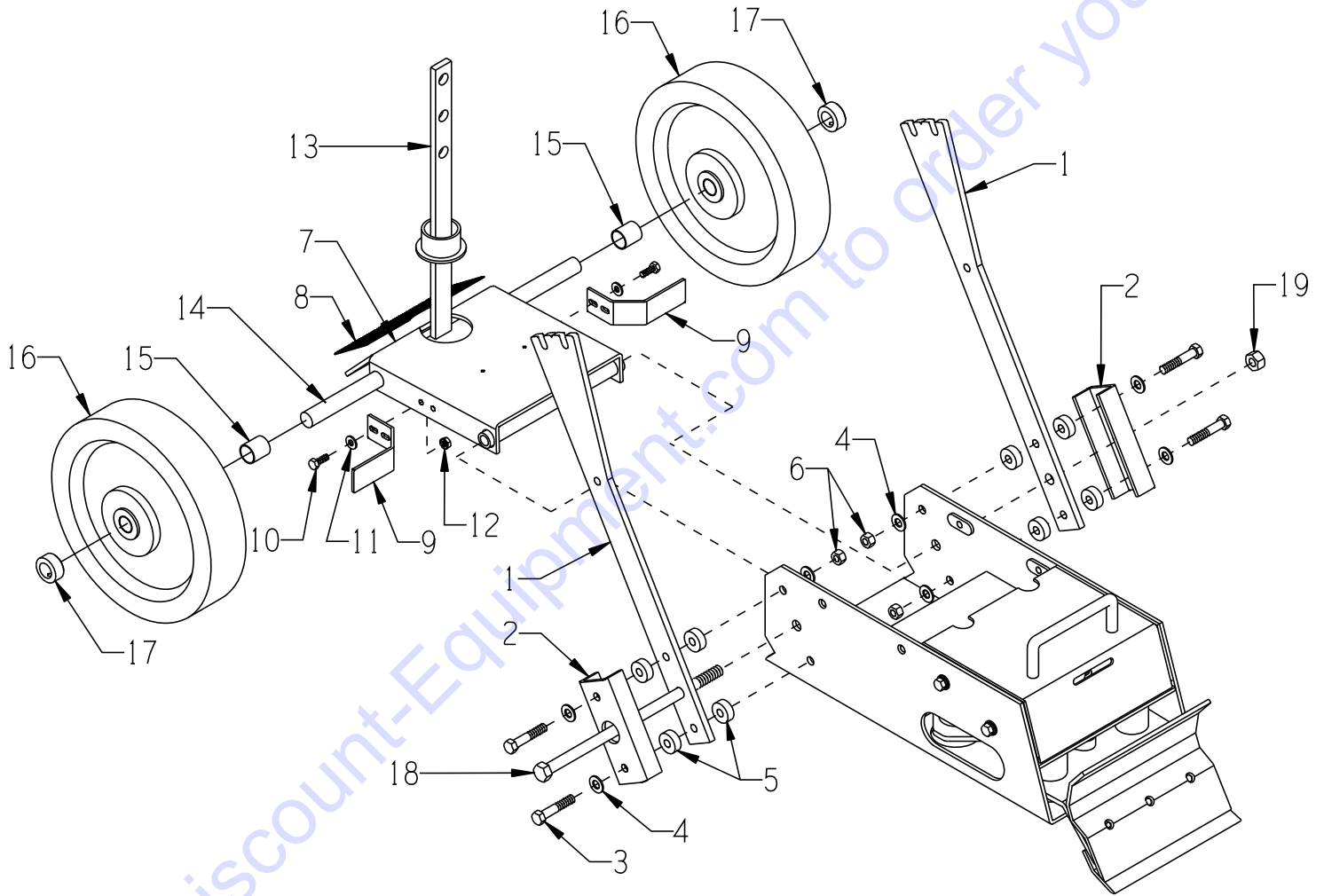

PARTS LISTING
ILLUSTRATION 2: WHEEL, FORK AND HANDLE LOWER LEG GROUPING

ITEM #	PART #	DESCRIPTION	QTY.
1	28117	LEG, HANDLE BAR LOWER, TILE SHARK	2
2	28110	MOUNTING BRKT., HANDLE BAR, TS-8	2
3	10030	SCREW, CAP 3/8-24 X 2	4
4	10025	WASHER, FLAT 3/8 SAE ZINC	8
5	40329	BUSHING, RUBBER 1"OD X 3/8"ID X 3/8	8
6	10004	NUT, HEX LOCK 3/8-24 ZINC	4
7	28103	FORK, TILE SHARK	1
8	28134	TREAD, ABRASIVE 2-1/2 X 7-1/2	1
9	28126	WIPER, WHEEL, TILE SHARK	2
10	10018	SCREW, CAP 1/4-20 X 3/4	4
11	10602	WASHER, FLAT 1/4 SAE ZINC	4
12	10861	NUT, KEPS LOCK 1/4-20 ZINC	4
13	28106	ADJUSTMENT BAR, ANGLE, TILE SHARK	1
14	28104	AXLE SHAFT 3/4"DIA. X 17, TS-8	1
15	28105	SPACER, WHEEL, TILE SHARK 13/16"ID x 15/16"OD x 7/8"L	2
16	28129	WHEEL, PHENOLIC 10 X 2-1/2 X 3/4BRG	2
17	10428	COLLAR, LOCKING 3/4"ID	2
18	10355	SCREW, CAP 1/2-13 X 11	1
19	10407	NUT, HEX LOCK 1/2-13 ZINC	1



ILLUSTRATION 3: HANDLE GROUPING

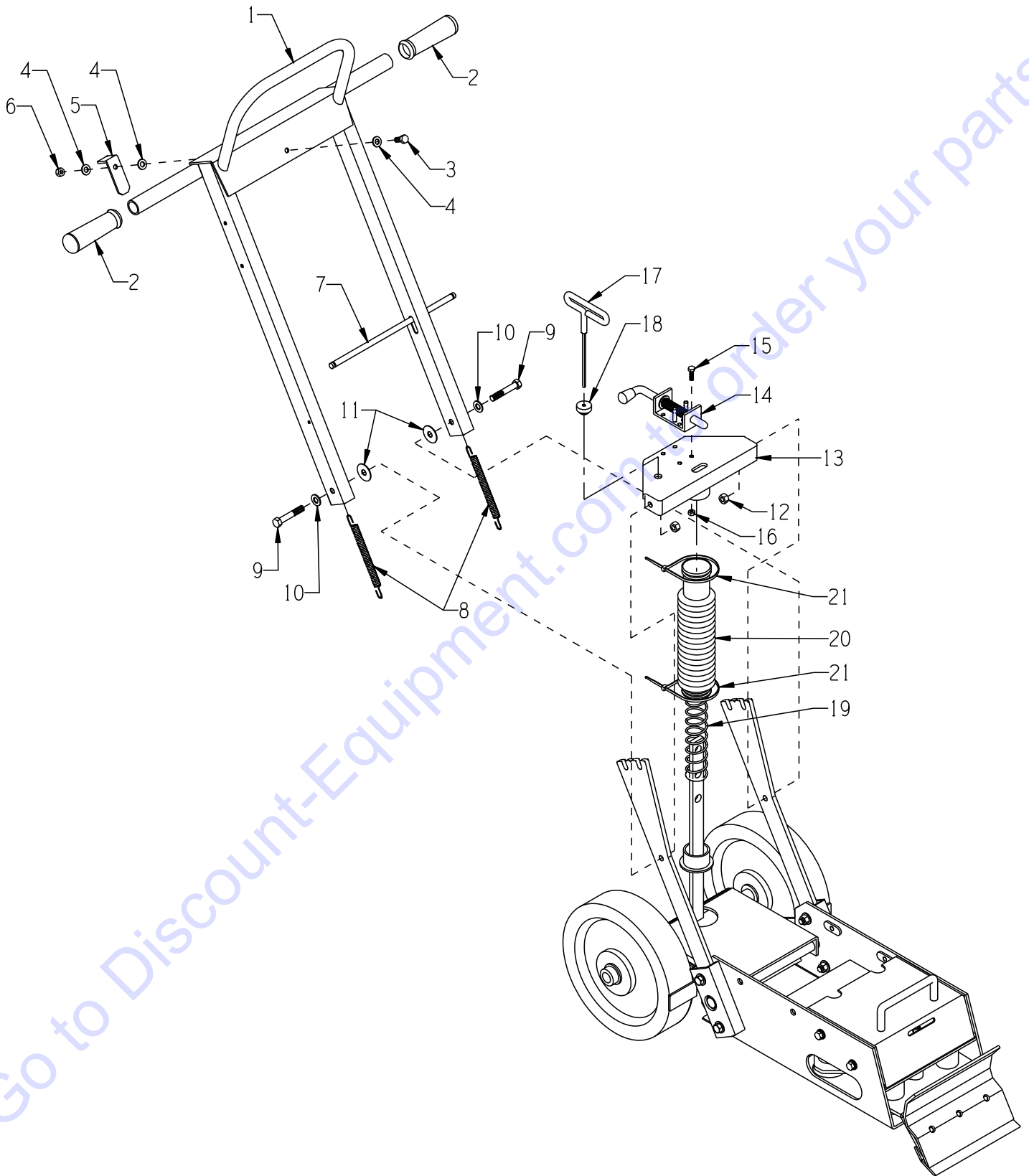

Go to Discount-Equipment.com to order your parts

PARTS LISTING ILLUSTRATION 3: HANDLE GROUPING			
ITEM #	PART #	DESCRIPTION	QTY.
1	28109	HANDLE BAR, TILE SHARK	1
2	10608	GRIP, HAND 1" MODEL AT	2
3	10053	SCREW, CAP 5/16-18 X 3/4	1
4	10213	WASHER, FLAT 5/16 SAE ZINC	3
5	28125	LATCH, HANDLE HOLD DOWN, TILE SHARK	1
6	10807	NUT, HEX LOCK 5/16-18 ZINC	1
7	28118	ROD, HANDLE SPRING, TILE SHARK 3/8"DIA. X 11-3/8"L	1
8	3636	SPRING, EXT. 6"L	2
9	10336	SCREW, CAP 3/8-24 X 2-1/4	2
10	10025	WASHER, FLAT 3/8 SAE ZINC	2
11	28133	WASHER, FLAT 13/32 X 1-1/4 X .047	2
12	10004	NUT, HEX LOCK 3/8-24 ZINC	2
13	28147	LATCH SUPPORT WELDMENT, TILE SHARK	1
14	72304	LATCH, SPRING 1/2" SNAP LOCK	1
15	11634	SCREW, CAP M6 X 1.0P X 20MM	4
16	28026	NUT, HEX NYLON LOCK M6 X 1MM	4
17	28132	WRENCH, HEX KEY 3/16, T-HANDLE	1
18	28122	RUBBER PLUG, HEX KEY WRENCH NOTE: HOLE IS DRILLED OUT TO 1/4"	1
19	28107	SPRING, COMP. 1.468"OD X 11"FL	1
20	24761	BELLOWS 1-3/4"ID X 10-1/4"LG	1
21	10982	TIE, CABLE, BLACK NYLON 11-1/4"	2



ILLUSTRATION 4: MOTOR GROUPING

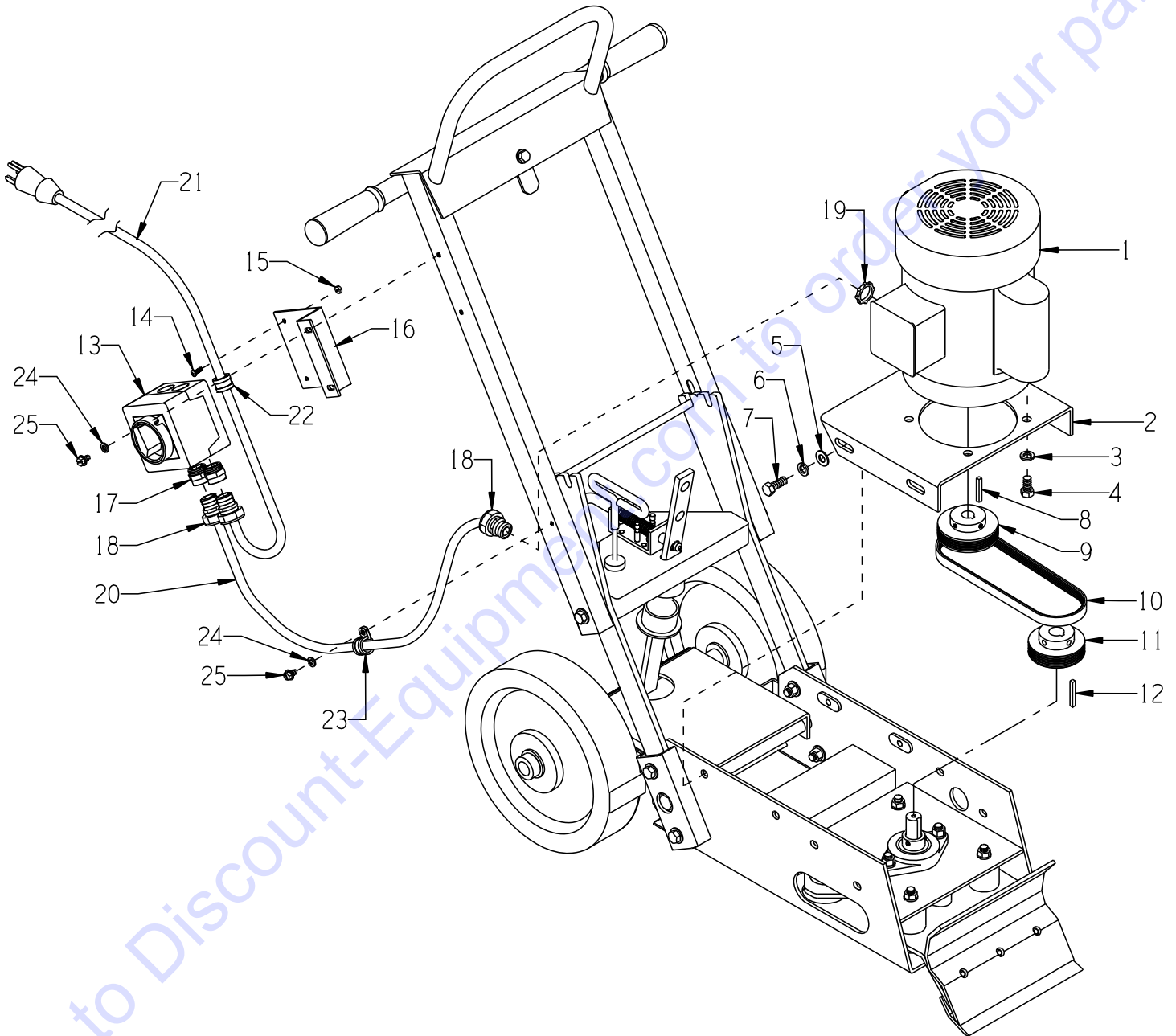

**PARTS LISTING
ILLUSTRATION 4: MOTOR GROUPING**

ITEM #	PART #	DESCRIPTION	QTY.
1		MOTOR, LEESON C-FACE (SEE 60 OR 50 HZ. BELOW)	
	16045	MOTOR .75HP 60HZ 1-PHASE, 115/208-230V (CAT. NO. 116664.00)	1
		REPLACEMENT PARTS:	
	16182	CAPACITOR, START, LEESON 003024.48 (600 MFD, 115V)	1
	16153	RESET BUTTON, LEESON 300002.02 (CEJ53CA)	1
	16051	MOTOR .75HP 50HZ 1-PHASE 110/220V (CAT. NO. 116930.00)	1
		REPLACEMENT PARTS:	
	16516	CAPACITOR, START, LEESON 003024.16 (440 MFD, 125V)	1
	16517	RESET BUTTON, LEESON 300031.02 (CED2715)	1
2	28111	MOUNT, MOTOR, TILE SHARK	1
3	10811	WASHER, LOCK 3/8 ZINC	4
4	10907	SCREW, CAP 3/8-16 X 3/4	4
5	10025	WASHER, FLAT 3/8 SAE ZINC	4
6	10811	WASHER, LOCK 3/8 ZINC	4
7	10055	SCREW, CAP 3/8-16 X 1	4
8	-----	KEY 3/16SQ X 1-3/8 (INCLUDED WITH MOTOR)	-
9	28131	SHEAVE 3.0"OD X 6GR.J X 5/8"BORE (60Hz MODEL)	1
	28069	SHEAVE 3.5"OD X 6GR.J X 5/8"BORE (50Hz MODEL)	1
10	28113	BELT 220J-6 V RIBBED	1
11	28130	SHEAVE 2.80"OD X 6GR.J X 3/4"BORE	1
12	10016	KEY 3/16SQ X 1-1/2	1
13	77043	SWITCH, ROTARY CAM ON/OFF	1
14	11663	SCREW, MACHINE 8-32 X 1/2 RHCD ZINC NOTE: THIS SCREW IS LOCATED INSIDE THE SWITCH BOX	4
15	10462	NUT, KEPS LOCK 8-32 ZINC	4
16	77042	BRACKET, ROTARY CAM SWITCH	1
17	77043-1	SWITCH ADAPTER, PG16 TO 1/2"NPT	2
18	41130	STRAIN RELIEF 1/2NPT X .550-.650" (CG50A-650)	3
19	10790	CONDUIT LOCK NUT 1/2 NP NOTE: THIS NUT IS LOCATED INSIDE THE JUNCTION BOX	1
20	77045	WIRE HARNESS 12/3 X 42"LOA (CORD SJOOW 300V)	1
21	86422	CORD W/ PLUG, 25FT. POWER 12/3 SJOOW 300V CORD WITH MOLDED STRAIGHT BLADE PLUG. NOTE: PLUG IS NEMA 5-15P 15A/125V FOR DOMESTIC USE ONLY. FOREIGN UNITS HAVE THE PLUG REMOVED.	1
22	11690	CLAMP, LOOM, 3/8"	1
23	11565	CLAMP, LOOM, 5/8" (SAE SIZE 10)	1
24	10038	WASHER, LOCK 1/4 ZINC	2
25	10846	SCREW, CAP STSHW 1/4-20 X 1/2	2



WIRING DIAGRAM FOR SWITCH

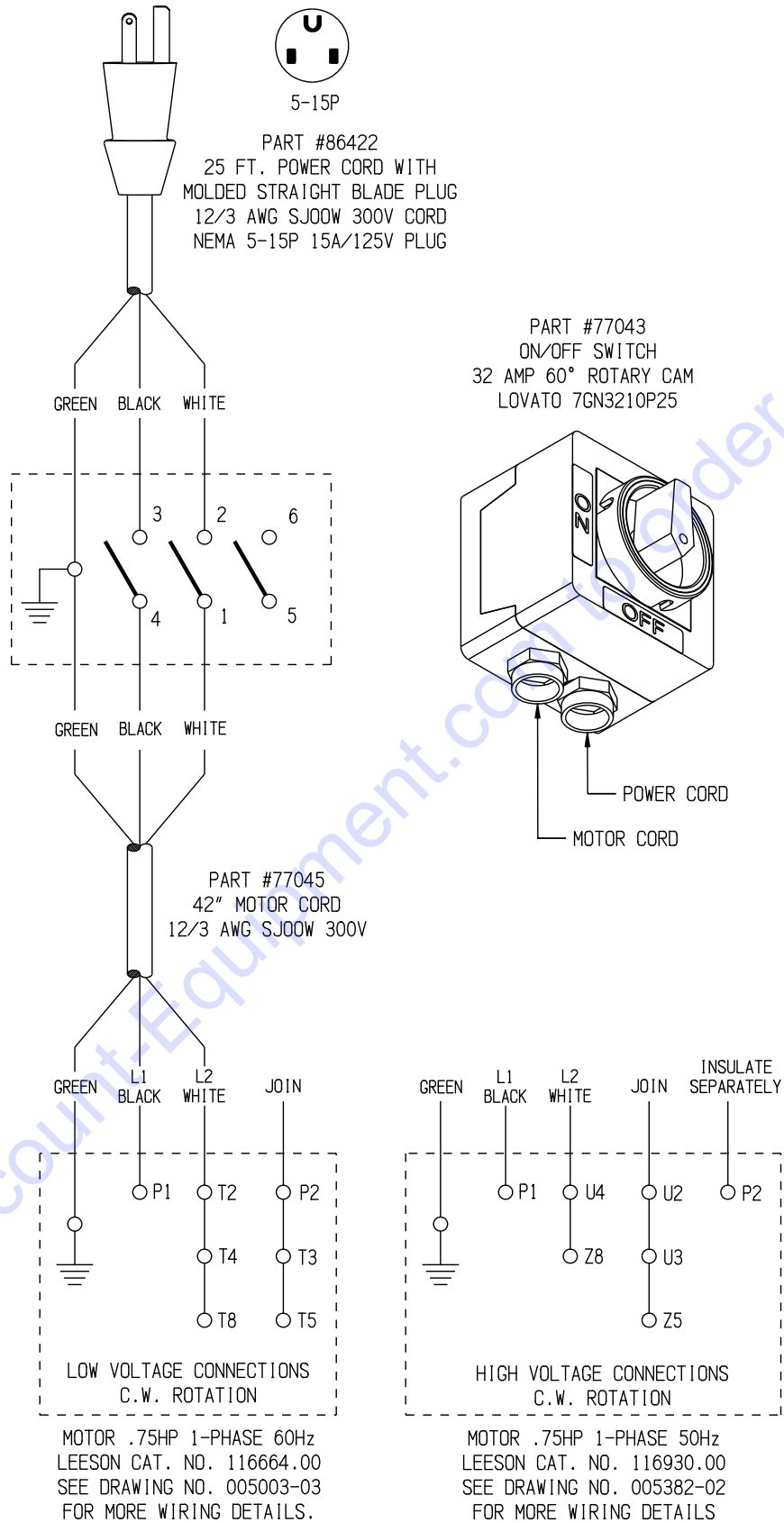

Go to DiscountEquipment.com to order your parts

WIRING DIAGRAMS FOR MOTOR

E-TS8-PL-0913

60 Hz MOTOR - LEESON CAT. NO. 116664

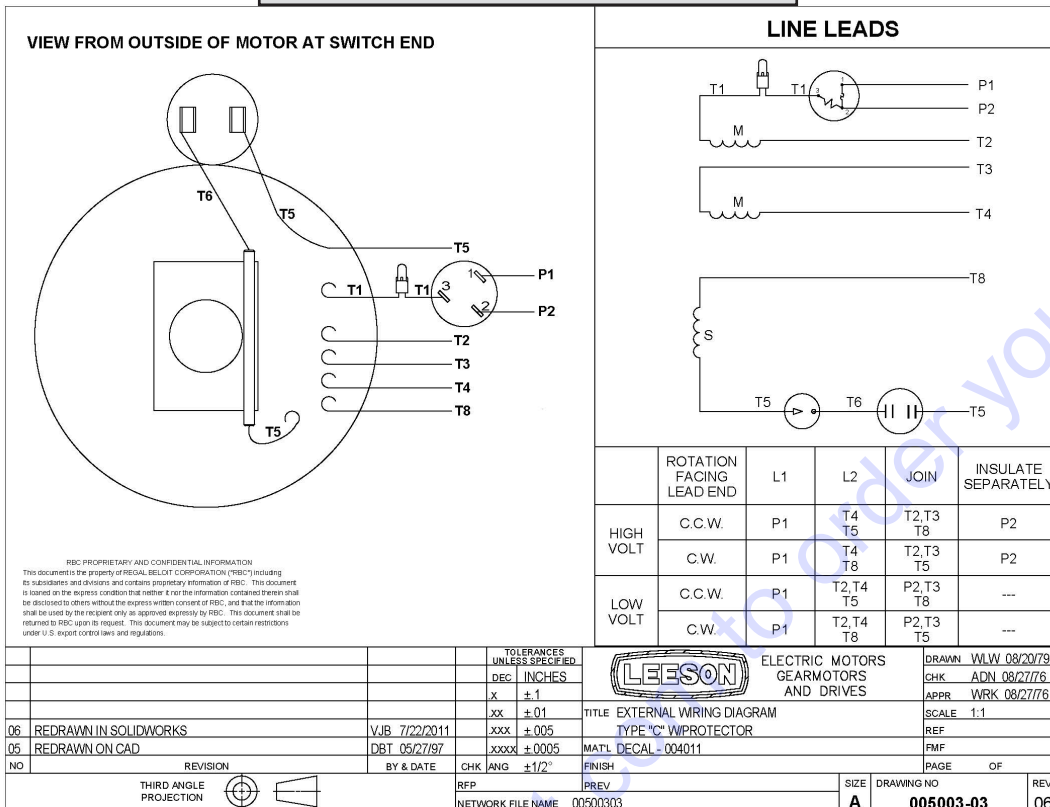

50 Hz MOTOR - LEESON CAT. NO. 116930

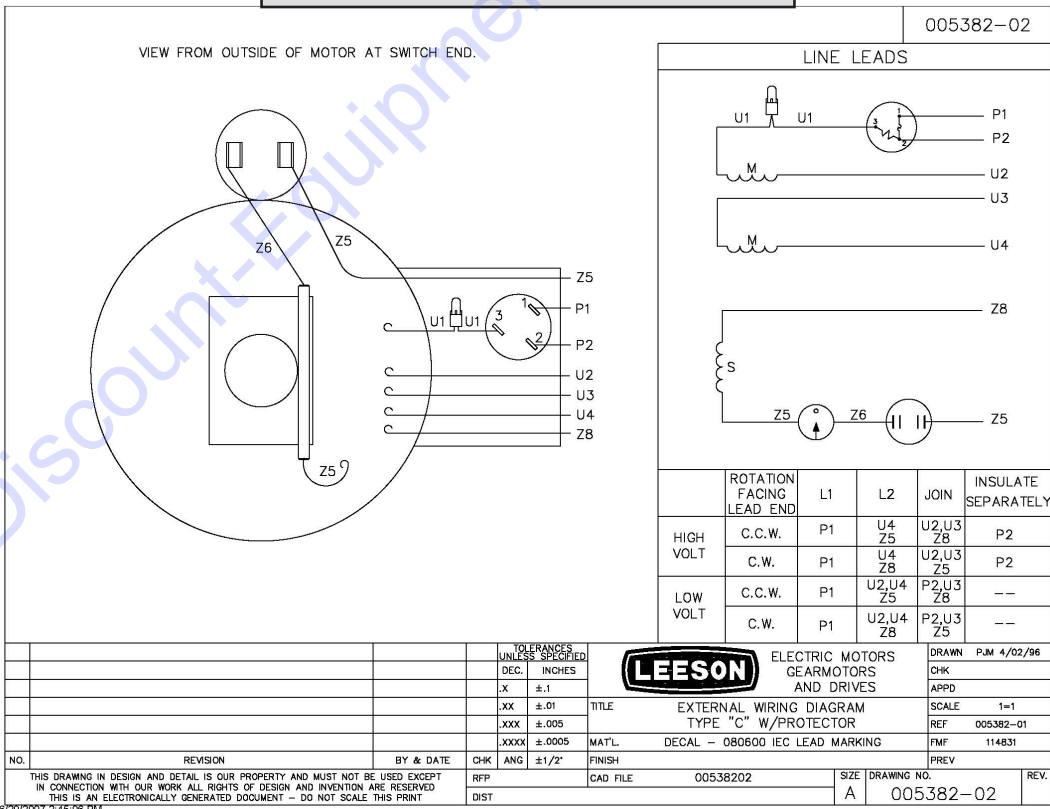

PARTS FINDER

**Search Website
by Part Number**



**Search Manual
Library For Parts
Manual & Lookup Part
Numbers – Purchase
or Request Quote**

Search Manuals

Enter your information to help us find the right parts manual for your machine.

* Brand:

* Model:

* Serial:

* Part Number:

SEARCH

**Can't Find Part or
Manual? Request Help
by Manufacturer,
Model & Description**

Parts Order Form

Please fill in the following information to help us find the right part for your machine.

Manufacturer:	<input type="text"/>
Model:	<input type="text"/>
Description:	<input type="text"/>
Part Number:	<input type="text"/>
Quantity:	<input type="text"/>
Notes:	<input type="text"/>

Submit

Discount-Equipment.com is your online resource for quality parts & equipment.

Florida: **561-964-4949** Outside Florida TOLL FREE: **877-690-3101**

Need parts?

Click on this link: <http://www.discount-equipment.com/category/5443-parts/> and choose one of the options to help get the right parts and equipment you are looking for. Please have the machine model and serial number available in order to help us get you the correct parts. If you don't find the part on the website or on one of the online manuals, please fill out the request form and one of our experienced staff members will get back to you with a quote for the right part that your machine needs.

We sell worldwide for the brands: Genie, Terex, JLG, MultiQuip, Mikasa, Essick, Whiteman, Mayco, Toro Stone, Diamond Products, Generac Magnum, Airman, Haulotte, Barreto, Power Blanket, Nifty Lift, Atlas Copco, Chicago Pneumatic, Allmand, Miller Curber, Skyjack, Lull, Skytrak, Tsurumi, Husquvarna Target, Stow, Wacker, Sakai, Mi-T-M, Sullair, Basic, Dynapac, MBW, Weber, Bartell, Bennar Newman, Haulotte, Ditch Runner, Menegotti, Morrison, Contec, Buddy, Crown, Edco, Wyco, Bomag, Laymor, EZ Trench, Bil-Jax, F.S. Curtis, Gehl Pavers, Heli, Honda, ICS/PowerGrit, IHI, Partner, Imer, Clipper, MMD, Koshin, Rice, CH&E, General Equipment, Amida, Coleman, NAC, Gradall, Square Shooter, Kent, Stanley, Tamco, Toku, Hatz, Kohler, Robin, Wisconsin, Northrock, Oztec, Toker TK, Rol-Air, APT, Wylie, Ingersoll Rand / Doosan, Innovatech, Con X, Ammann, Mecalac, Makinex, Smith Surface Prep, Small Line, Wanco, Yanmar