

REVISED STARTING SERIAL # 080810103

PARTS LIST MANUAL

8" TILE STRIPPER



TS8 TILE SHARK

SKU #	MODEL #	POWER OPTION
94400	TS8-.75L	LEESON .75 HP ELECTRIC MOTOR, 60Hz, 1 PHASE, 115/208-230V, 10.8/5.4 F.L.AMPS
94500	TS8-.75L/50H	LEESON .75 HP ELECTRIC MOTOR, 50Hz, 1 PHASE, 110/220V, 11.8/5.9 F.L.AMPS



A Division of Equipment Development Company, Inc.



Printed in USA

©2008

PARTS FINDER

**Search Website
by Part Number**



**Search Manual
Library For Parts
Manual & Lookup Part
Numbers – Purchase
or Request Quote**

Search Manuals

Enter your information to help us find the right parts manual for your machine.

* Brand:

* Model:

* Serial:

* Part Number:

SEARCH

**Can't Find Part or
Manual? Request Help
by Manufacturer,
Model & Description**

Parts Order Form

Please fill in the following information to help us find the right part for your machine.

Manufacturer:	<input type="text"/>
Model:	<input type="text"/>
Description:	<input type="text"/>
Part Number:	<input type="text"/>
Quantity:	<input type="text"/>
Notes:	<input type="text"/>

Discount-Equipment.com is your online resource for quality parts & equipment.

Florida: **561-964-4949** Outside Florida TOLL FREE: **877-690-3101**

Need parts?

Click on this link: <http://www.discount-equipment.com/category/5443-parts/> and choose one of the options to help get the right parts and equipment you are looking for. Please have the machine model and serial number available in order to help us get you the correct parts. If you don't find the part on the website or on one of the online manuals, please fill out the request form and one of our experienced staff members will get back to you with a quote for the right part that your machine needs.

We sell worldwide for the brands: Genie, Terex, JLG, MultiQuip, Mikasa, Essick, Whiteman, Mayco, Toro Stone, Diamond Products, Generac Magnum, Airman, Haulotte, Barreto, Power Blanket, Nifty Lift, Atlas Copco, Chicago Pneumatic, Allmand, Miller Curber, Skyjack, Lull, Skytrak, Tsurumi, Husquvarna Target, Stow, Wacker, Sakai, Mi-T-M, Sullair, Basic, Dynapac, MBW, Weber, Bartell, Bennar Newman, Haulotte, Ditch Runner, Menegotti, Morrison, Contec, Buddy, Crown, Edco, Wyco, Bomag, Laymor, EZ Trench, Bil-Jax, F.S. Curtis, Gehl Pavers, Heli, Honda, ICS/PowerGrit, IHI, Partner, Imer, Clipper, MMD, Koshin, Rice, CH&E, General Equipment, Amida, Coleman, NAC, Gradall, Square Shooter, Kent, Stanley, Tamco, Toku, Hatz, Kohler, Robin, Wisconsin, Northrock, Oztec, Toker TK, Rol-Air, APT, Wylie, Ingersoll Rand / Doosan, Innovatech, Con X, Ammann, Mecalac, Makinex, Smith Surface Prep, Small Line, Wanco, Yanmar

READ AND UNDERSTAND THE OPERATORS INSTRUCTION MANUAL THOROUGHLY BEFORE ATTEMPTING TO OPERATE THIS EQUIPMENT. Death or serious injury could occur if this machine is used improperly.



SAFETY MESSAGES



The safety instructions are preceded by a graphic alert message of DANGER, WARNING, or CAUTION.



Indicates an imminent hazard which, if not avoided, will result in death or serious injury.



Indicates an imminent hazard which, if not avoided, can result in death or serious injury.



Indicates hazards which, if not avoided, could result in serious injury and or damage to the equipment.

GASOLINE Powered Equipment



- Do not operate gasoline powered equipment without adequate ventilation. Carbon monoxide is an invisible, odorless gas that can kill.

ELECTRICAL Powered Equipment



- ELECTRICAL HAZARD** - Be sure equipment is properly grounded. Failure to comply could kill or result in serious injury.



The engine exhaust from this product contains chemicals known to the State of California to cause cancer, birth defects or other reproductive harm.

GENERAL INSTRUCTIONS



- You must read and understand the operators instruction manual and all other manuals associated with this machine. For your safety and the safety of others around you, it is extremely important to fully understand how to operate this machine in the way it was intended. Different model machines or older/newer versions of the same model may have different parts and controls that you need to understand. If instructions are not readable or available DO NOT USE this machine and contact Discount-equipment for a replacement Manual.
- You must be able to physically handle the bulk weight and power of this machine. If not properly controlled this machine can cause death or serious injury.
- Do not operate this machine in an impaired mental state. You must be able to exercise good judgement and reactions to maintain a safe working environment.
- This is a "one person" machine which means only one operator can be operating the machine at any one time. For the safety of others, maintain a safe operating distance to other personnel. Your work area should be defined and appropriately marked so bystanders and coworkers do not stand or walk near this machine and end up seriously injured by flying debris or exposing them to harmful noise or dust.
- This equipment is for Commercial use. Although this is a "one person" machine your work team should understand how to shut this machine off and quickly get medical help if an accident strikes the operator.
- Keep all guards in place during operation. The guards are to provide protection from inadvertent contact with dangerous moving parts, pinch points, or hot surfaces.
- Wear appropriate Personal Protective Equipment (PPE) including safety glasses, safety boots, work gloves, respiratory protection, hearing protection, and head protection. Do not wear loose clothing that can get tangled in moving parts. Failure to do so could result

in dismemberment or death. **Wear an approved respirator when removing hazardous materials or when grinding/cutting dry materials. Some dust particles such as concrete dust can contain silicate particles which can cause silicosis (a very serious lung disease). Contact NIOSH or OSHA for further details. When wet grinding/cutting, avoid contact with the concrete/asphalt slurry which can cause serious skin irritations.**

- You must maintain this machine per the maintenance schedule in the operator manual. Remember before adjusting, servicing, or fueling this machine, disconnect the source of power to the machine by disconnecting the spark plug (Gas models), or by unplugging the electrical power cord (electric models) or air hose (Pneumatic models) AT THE MACHINE so you can assure yourself it remains unplugged while you are working on it. Do not modify this machine. Use only genuine EDCO parts and accessories. Repairs and service should be performed by approved EDCO dealers or authorized technicians.
- You should look carefully around the area before you begin work so you can identify potential hazards such as deck inserts, pipes, columns, openings, electrical cords or outlets, or any other objects protruding from the slab surface.
- This machine has no brain so you must use your own. There is no substitute for safety. The safety decals on the machine are to serve as a reminder for information you must already know before you begin using this machine. Take a moment to reread the safety decals each time you use the machine. If your machine is missing any decals, contact Discount-equipment for a replacement.

PARTS LIST MANUAL

MODEL TS8

<u>Section</u>	<u>Page Number</u>
Safety Messages / General Instructions.	2
How To Order Replacement Parts.	3
Illustration 1 : Main Grouping	4,5
Illustration 2 : Handle Grouping	6,7
Illustration 3 : Motor Grouping	8,9
Illustration 4 : 50/60Hz 1-Phase Wiring Diagram	10
Limited Equipment Warranty of Sale.	Back Page

Go to Discount-Equipment.com to order your parts



A Division of Equipment Development Company, Inc.

ILLUSTRATION 1: MAIN GROUPING

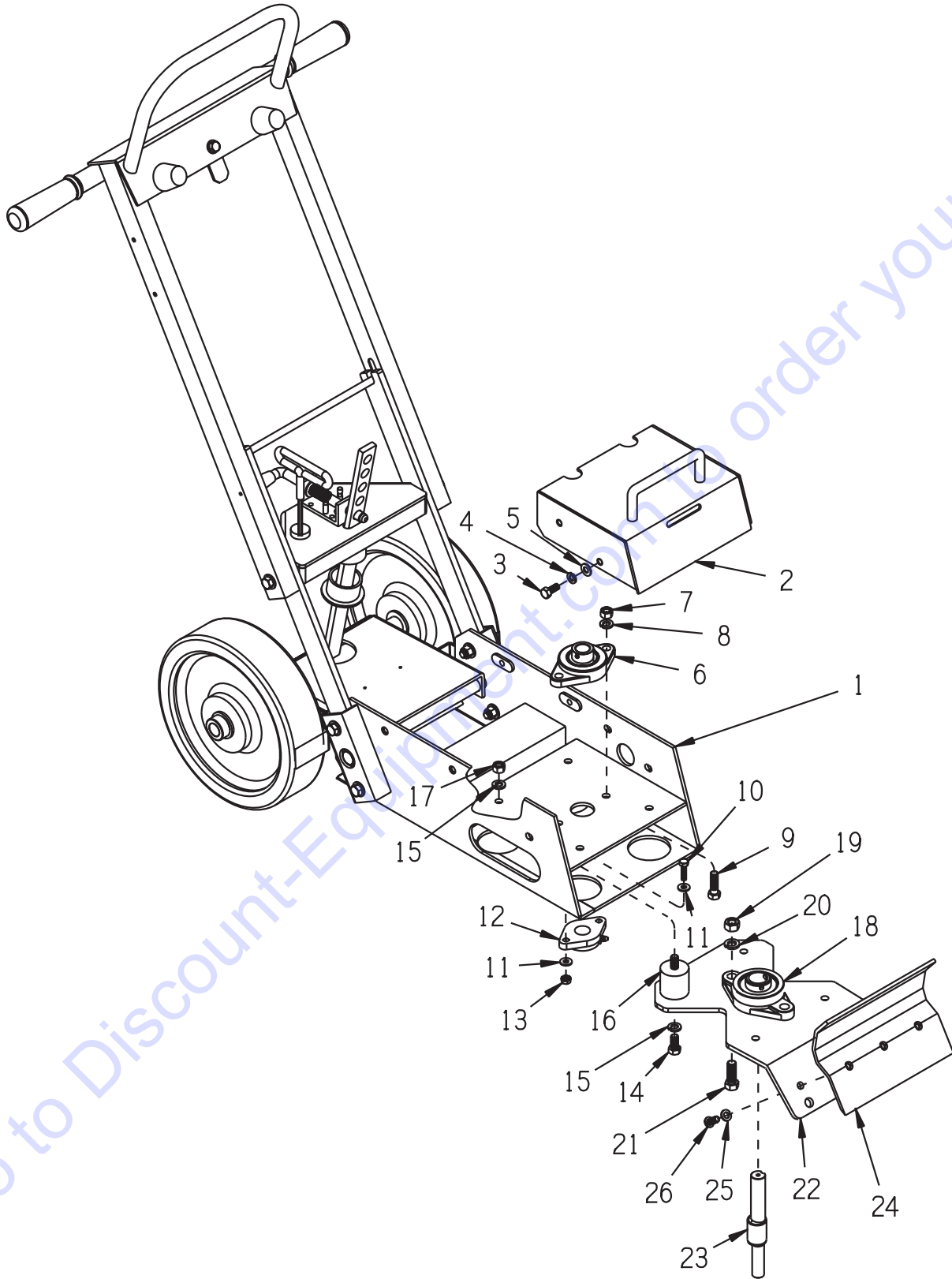

PARTS LISTING - ILLUSTRATION 1: MAIN GROUPING

ITEM#	PART#	DESCRIPTION	QTY.
1	28101	MAIN FRAME	1
2	28137	HOOD	1
3	10053	SCREW, CAP 5/16-18 X 3/4	4
4	10801	WASHER, LOCK 5/16	4
5	10213	WASHER, FLAT 5/16 SAE	4
6	50049	BEARING, BALL 3/4" 2-HOLE FLANGE	1
7	10014	NUT 3/8-24	2
8	10811	WASHER, LOCK 3/8	2
9	10309	SCREW, CAP 3/8-24 X 1-1/4 PLATED	2
10	10031	SCREW, CAP 1/4-20 X 1	2
11	10602	WASHER, FLAT 1/4 SAE	4
12	80009G	BEARING, BALL 5/8" 2-HOLE (W/ G.F.)	1
13	10861	NUT, KEPS 1/4-20	2
14	10907	SCREW, CAP 3/8-16 X 3/4	4
15	10811	WASHER, LOCK 3/8	8
16	28115	MOUNT, FLEX-BOLT SANDWICH 3/8-16	4
17	10404	NUT 3/8-16	4
18	62022	BEARING, BALL 1" 2-HOLE FLANGE	1
19	10481	NUT 7/16-20	2
20	10450	WASHER, LOCK 7/16	2
21	10003	SCREW, CAP 7/16-20 X 1-1/4	2
22	28145	STRIKER PLATE	1
23	28116	CAM SHAFT, STRIKER PLATE	1
24	28146	RETAINER, SCRAPER BLADE	1
25	10801	WASHER, LOCK 5/16	3
26	10627	SCREW, SKT. BUTTON HD. 5/16-18 X3/4	3



A Division of Equipment Development Company, Inc.

ILLUSTRATION 2: HANDLE GROUPING

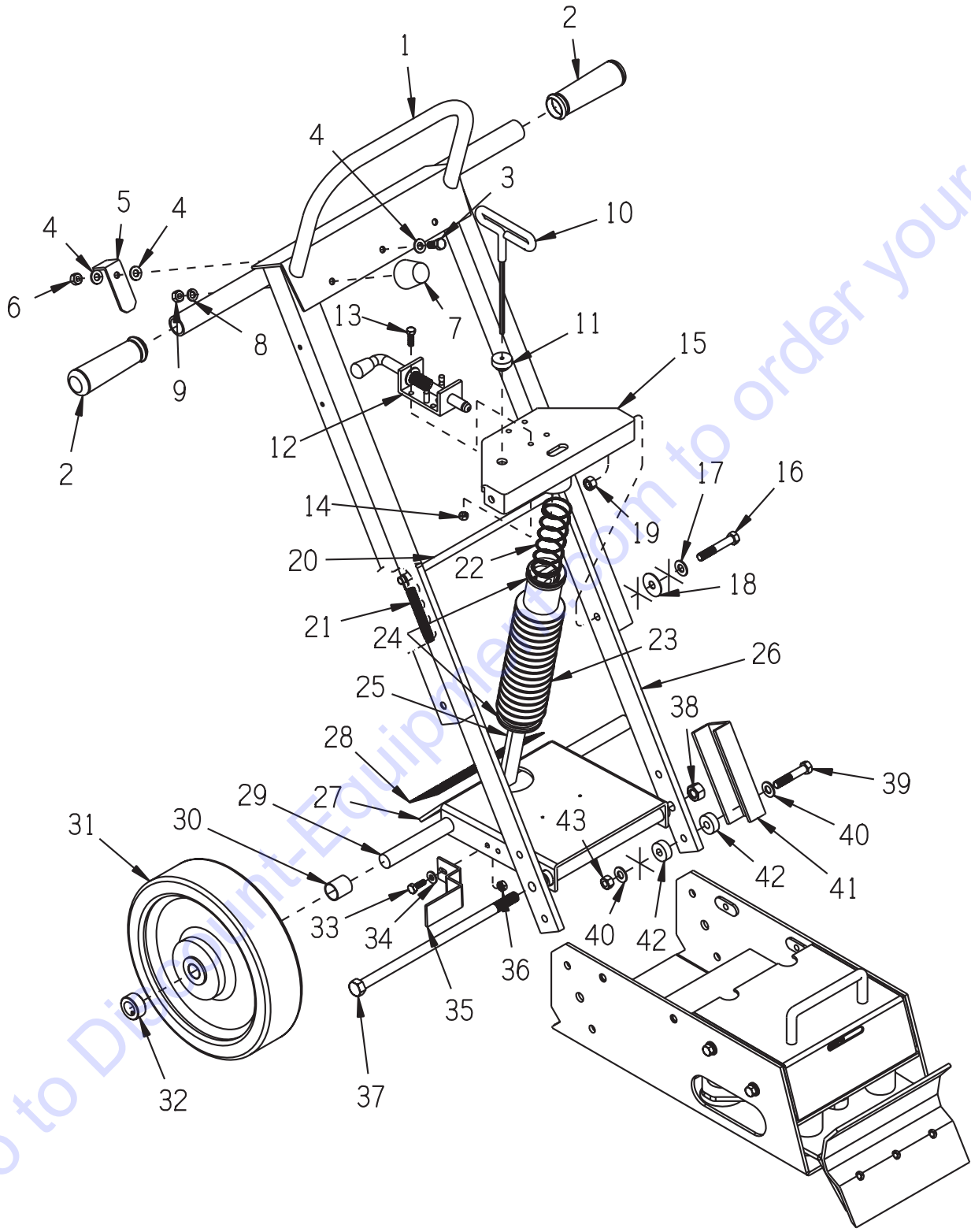

PARTS LISTING - ILLUSTRATION 2: HANDLE GROUPING

ITEM#	PART#	DESCRIPTION	QTY.
1	28109	HANDLE BAR	1
2	10608	GRIP, HAND 1" MODEL AT	2
3	10053	SCREW, CAP 5/16-18 X 3/4	1
4	10213	WASHER, FLAT 5/16 SAE (SHIM LATCH AS NEEDED)	3
5	28125	LATCH, HANDLE HOLD DOWN	1
6	10807	NUT, LOCK 5/16-18	1
7	10931	MOUNT, TAPERED RUBBER 5/16-18	2
8	10801	WASHER, LOCK 5/16	2
9	10807	NUT, LOCK 5/16-18	2
10	28132	WRENCH, HEX KEY 3/16, T-HANDLE	1
11	28122	RUBBER PLUG, HEX KEY WRENCH	1
12	72304	LATCH, SPRING 1/2" SNAP LOCK	1
13	11634	SCREW, CAP M6 X 1.0P X 20MM	4
14	28026	NUT, HEX NYLON LOCK M6 X 1MM	4
15	28147	LATCH SUPPORT WELDMENT	1
16	10336	SCREW, CAP 3/8-24 X 2-1/4	2
17	10025	WASHER, FLAT 3/8 SAE	2
18	28133	WASHER, FLAT 13/32 X 1-1/4 X .047	2
19	10004	NUT, LOCK 3/8-24	2
20	28118	ROD, HANDLE SPRING	1
21	3636	SPRING, EXT. 6"L	2
22	28107	SPRING, COMP. 1.468"OD X 11"FL	1
23	24761	BELLOWS 1-3/4"ID X 10-1/4"LG	1
24	10982	TIE, CABLE, BLACK NYLON 11-1/4"	2
25	28106	ADJUSTMENT BAR, ANGLE	1
26	28117	LEG, HANDLE BAR LOWER	2
27	28103	FORK	1
28	28134	TREAD, ABRASIVE 2-1/2 X 7-1/2	1
29	28104	AXLE SHAFT 3/4"DIA. X 17	1
30	28105	SPACER, WHEEL	2
31	28129	WHEEL, PHENOLIC 10 X 2-1/2 X 3/4BRG	2
32	10428	COLLAR, LOCKING 3/4"ID	2
33	10018	SCREW, CAP 1/4-20 X 3/4	4
34	10602	WASHER, FLAT 1/4 SAE	4
35	28126	WIPER, WHEEL	2
36	10861	NUT, KEPS 1/4-20	4
37	10355	SCREW, CAP 1/2-13 X 11	1
38	10407	NUT, LOCK 1/2-13	1
39	10030	SCREW, CAP 3/8-24 X 2	4
40	10025	WASHER, FLAT 3/8 SAE	8
41	28110	MOUNTING BRKT., HANDLE BAR	2
42	40329	BUSHING, RUBBER 1"OD X 3/8"ID X 3/8	8
43	10004	NUT, LOCK 3/8-24	4



A Division of Equipment Development Company, Inc.

ILLUSTRATION 3: MOTOR GROUPING

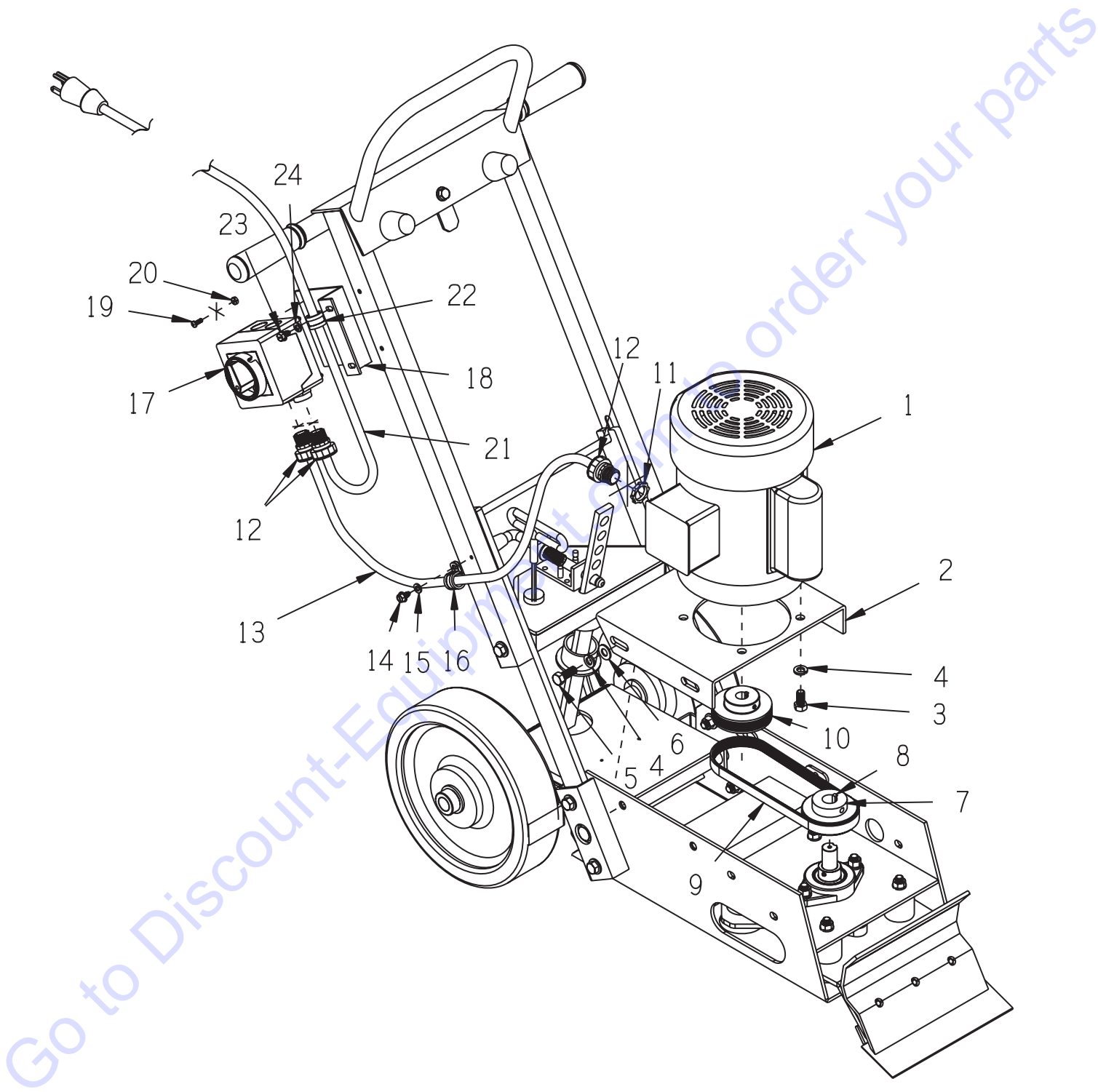

PARTS LISTING - ILLUSTRATION 3: MOTOR GROUPING			
ITEM#	PART#	DESCRIPTION	QTY.
1		MOTOR, LEESON (INCLUDES KEY)	1
	16045	.75HP 60HZ, 1 PHASE, 115/208-230 VOLT, 1725RPM	
		<u>REPLACEMENT PARTS:</u>	
	16182	CAPACITOR, START, LEESON 003024.48 (600MFD 115V)	1
	16153	RESET BUTTON, LEESON 300002.02 (CEJ53CA)	1
	16051	.75HP 50HZ, 1 PHASE, 110/220 VOLT, 1425RPM	
		<u>REPLACEMENT PARTS:</u>	
	16516	CAPACITOR, START, LEESON 003024.16 (440MFD 125V)	1
	16517	RESET BUTTON, LEESON 300031.02 (CED2715)	1
2	28111	MOUNT, MOTOR	1
3	10907	SCREW, CAP 3/8-16 X 3/4	4
4	10811	WASHER, LOCK 3/8	8
5	10055	SCREW, CAP 3/8-16 X 1	4
6	10025	WASHER, FLAT 3/8 SAE	4
7	28130	SHEAVE 2.80"OD X 6GR.J X 3/4"BORE	1
8	10016	KEY 3/16SQ X 1-1/2	1
9	28113	BELT 220J-6 V RIBBED	1
10	28131	SHEAVE 3.0"OD X 6GR.J X 5/8"BORE	1
11	10790	CONDUIT LOCK NUT 1/2 NP	1
12	41130	STRAIN RELIEF 1/2NPT X .550-.650"	3
13	77045	WIRE HARNESS 12/3 X 42"LOA	1
14	10846	SCREW, CAP STSHW 1/4-20 X 1/2	1
15	10038	WASHER, LOCK 1/4	1
16	11565	CLAMP, LOOM, 5/8" (SAE SIZE 10)	1
17	77043	SWITCH, ROTARY CAM ON/OFF, LOVATO	1
18	77042	BRACKET, LOVATO ROTARY CAM SWITCH	1
19	11663	SCREW, MACHINE 8-32 X 1/2	4
20	10462	NUT, KEPS 8-32	4
21	86422	CORD W/ PLUG, 25FT. POWER	1
22	11690	CLAMP, LOOM, 3/8"	1
23	10846	SCREW, CAP STSHW 1/4-20 X 1/2	2
24	10038	WASHER, LOCK 1/4	2

ILLUSTRATION 4: 50/60Hz 1Ø WIRING DIAGRAM

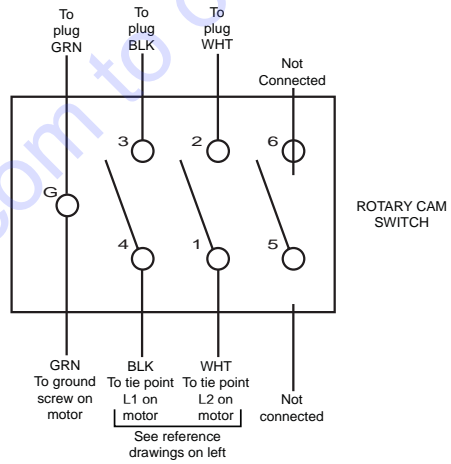
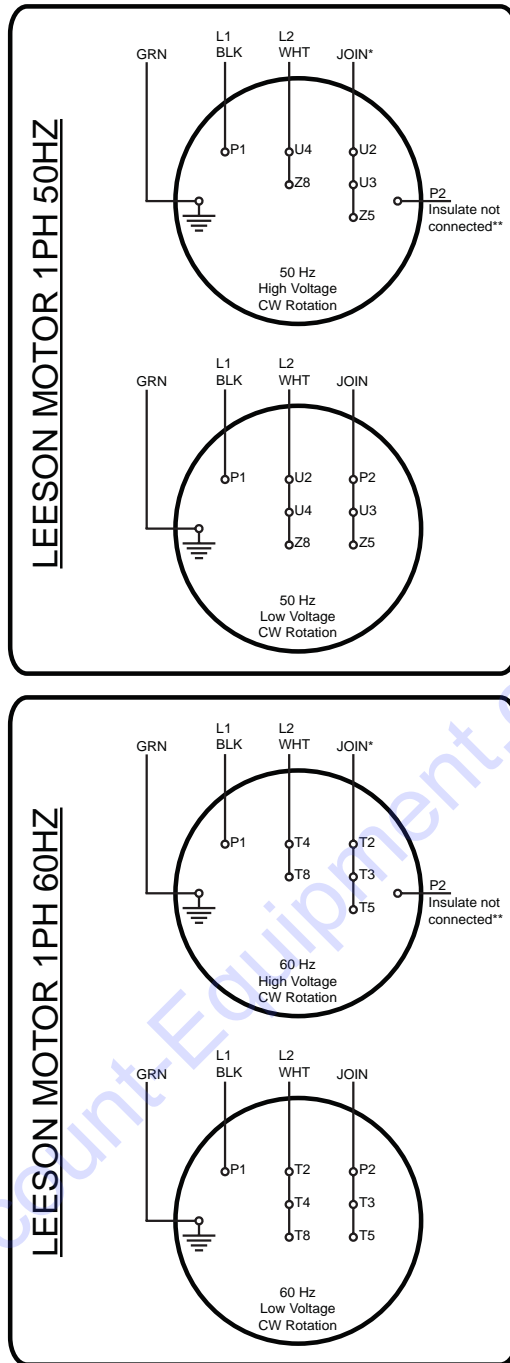

NOTES:

- * Twist these wires together and use a wire nut to secure connection.
- ** This wire is not used, insulate with electrical tape.

WIRING SCHEMES

TS8-50/60_1-PhaseWD.1

PARTS FINDER

**Search Website
by Part Number**



**Search Manual
Library For Parts
Manual & Lookup Part
Numbers – Purchase
or Request Quote**

Search Manuals

Enter your information to help us find the right parts manual for your machine.

* Brand:

* Model:

* Serial:

* Part Number:

SEARCH

**Can't Find Part or
Manual? Request Help
by Manufacturer,
Model & Description**

Parts Order Form

Please fill in the following information to help us find the right part for your machine.

Manufacturer:	<input type="text"/>
Model:	<input type="text"/>
Description:	<input type="text"/>
Part Number:	<input type="text"/>
Quantity:	<input type="text"/>
Notes:	<input type="text"/>

Submit

Discount-Equipment.com is your online resource for quality parts & equipment.

Florida: **561-964-4949** Outside Florida TOLL FREE: **877-690-3101**

Need parts?

Click on this link: <http://www.discount-equipment.com/category/5443-parts/> and choose one of the options to help get the right parts and equipment you are looking for. Please have the machine model and serial number available in order to help us get you the correct parts. If you don't find the part on the website or on one of the online manuals, please fill out the request form and one of our experienced staff members will get back to you with a quote for the right part that your machine needs.

We sell worldwide for the brands: Genie, Terex, JLG, MultiQuip, Mikasa, Essick, Whiteman, Mayco, Toro Stone, Diamond Products, Generac Magnum, Airman, Haulotte, Barreto, Power Blanket, Nifty Lift, Atlas Copco, Chicago Pneumatic, Allmand, Miller Curber, Skyjack, Lull, Skytrak, Tsurumi, Husquvarna Target, Stow, Wacker, Sakai, Mi-T-M, Sullair, Basic, Dynapac, MBW, Weber, Bartell, Bennar Newman, Haulotte, Ditch Runner, Menegotti, Morrison, Contec, Buddy, Crown, Edco, Wyco, Bomag, Laymor, EZ Trench, Bil-Jax, F.S. Curtis, Gehl Pavers, Heli, Honda, ICS/PowerGrit, IHI, Partner, Imer, Clipper, MMD, Koshin, Rice, CH&E, General Equipment, Amida, Coleman, NAC, Gradall, Square Shooter, Kent, Stanley, Tamco, Toku, Hatz, Kohler, Robin, Wisconsin, Northrock, Oztec, Toker TK, Rol-Air, APT, Wylie, Ingersoll Rand / Doosan, Innovatech, Con X, Ammann, Mecalac, Makinex, Smith Surface Prep, Small Line, Wanco, Yanmar