



Revised Starting Serial # 1011

PARTS LIST MANUAL

Tile Shark™ 8" Floor Stripper



Model TS-8
Part No. 94400



PARTS FINDER

**Search Website
by Part Number**



**Search Manual
Library For Parts
Manual & Lookup Part
Numbers – Purchase
or Request Quote**

Search Manuals

Enter your information to help us find the right parts manual for your machine.

* Brand:

* Model:

* Serial:

* Part Number:

SEARCH

**Can't Find Part or
Manual? Request Help
by Manufacturer,
Model & Description**

Parts Order Form

Please fill in the following information to help us find the right part for your machine.

Manufacturer:	<input type="text"/>
Model:	<input type="text"/>
Description:	<input type="text"/>
Part Number:	<input type="text"/>
Quantity:	<input type="text"/>
Notes:	<input type="text"/>

Discount-Equipment.com is your online resource for quality parts & equipment.

Florida: **561-964-4949** Outside Florida TOLL FREE: **877-690-3101**

Need parts?

Click on this link: <http://www.discount-equipment.com/category/5443-parts/> and choose one of the options to help get the right parts and equipment you are looking for. Please have the machine model and serial number available in order to help us get you the correct parts. If you don't find the part on the website or on one of the online manuals, please fill out the request form and one of our experienced staff members will get back to you with a quote for the right part that your machine needs.

We sell worldwide for the brands: Genie, Terex, JLG, MultiQuip, Mikasa, Essick, Whiteman, Mayco, Toro Stone, Diamond Products, Generac Magnum, Airman, Haulotte, Barreto, Power Blanket, Nifty Lift, Atlas Copco, Chicago Pneumatic, Allmand, Miller Curber, Skyjack, Lull, Skytrak, Tsurumi, Husquvarna Target, Stow, Wacker, Sakai, Mi-T-M, Sullair, Basic, Dynapac, MBW, Weber, Bartell, Bennar Newman, Haulotte, Ditch Runner, Menegotti, Morrison, Contec, Buddy, Crown, Edco, Wyco, Bomag, Laymor, EZ Trench, Bil-Jax, F.S. Curtis, Gehl Pavers, Heli, Honda, ICS/PowerGrit, IHI, Partner, Imer, Clipper, MMD, Koshin, Rice, CH&E, General Equipment, Amida, Coleman, NAC, Gradall, Square Shooter, Kent, Stanley, Tamco, Toku, Hatz, Kohler, Robin, Wisconsin, Northrock, Oztec, Toker TK, Rol-Air, APT, Wylie, Ingersoll Rand / Doosan, Innovatech, Con X, Ammann, Mecalac, Makinex, Smith Surface Prep, Small Line, Wanco, Yanmar

READ AND UNDERSTAND THE OPERATORS INSTRUCTION MANUAL THOROUGHLY BEFORE ATTEMPTING TO OPERATE THIS EQUIPMENT. Death or serious injury could occur if this machine is used improperly.



SAFETY MESSAGES



The safety instructions are preceded by a graphic alert message of DANGER, WARNING, or CAUTION.



Indicates an imminent hazard which, if not avoided, will result in death or serious injury.



Indicates an imminent hazard which, if not avoided, can result in death or serious injury.



Indicates hazards which, if not avoided, could result in serious injury and or damage to the equipment.

GASOLINE Powered Equipment



- Do not operate gasoline powered equipment without adequate ventilation. Carbon monoxide is an invisible, odorless gas that can kill.

ELECTRICAL Powered Equipment



- ELECTRICAL HAZARD** - Be sure equipment is properly grounded. Failure to comply could kill or result in serious injury.



The engine exhaust from this product contains chemicals known to the State of California to cause cancer, birth defects or other reproductive harm.

GENERAL INSTRUCTIONS



- You must read and understand the operators instruction manual and all other manuals associated with this machine. For your safety and the safety of others around you, it is extremely important to fully understand how to operate this machine in the way it was intended. Different model machines or older/newer versions of the same model may have different parts and controls that you need to understand. If instructions are not readable or available DO NOT USE this machine and contact Discount-equipment for a replacement Manual.
- You must be able to physically handle the bulk weight and power of this machine. If not properly controlled this machine can cause death or serious injury.
- Do not operate this machine in an impaired mental state. You must be able to exercise good judgement and reactions to maintain a safe working environment.
- This is a "one person" machine which means only one operator can be operating the machine at any one time. For the safety of others, maintain a safe operating distance to other personnel. Your work area should be defined and appropriately marked so bystanders and coworkers do not stand or walk near this machine and end up seriously injured by flying debris or exposing them to harmful noise or dust.
- This equipment is for Commercial use. Although this is a "one person" machine your work team should understand how to shut this machine off and quickly get medical help if an accident strikes the operator.
- Keep all guards in place during operation. The guards are to provide protection from inadvertent contact with dangerous moving parts, pinch points, or hot surfaces.
- Wear appropriate Personal Protective Equipment (PPE) including safety glasses, safety boots, work gloves, respiratory protection, hearing protection, and head protection. Do not wear loose clothing that can get tangled in moving parts. Failure to do so could result in dismemberment or death. **Wear an approved respirator when removing hazardous materials or when grinding/cutting dry materials. Some dust particles such as concrete dust can contain silicate particles which can cause silicosis (a very serious lung disease). Contact NIOSH or OSHA for further details. When wet grinding/cutting, avoid contact with the concrete/asphalt slurry which can cause serious skin irritations.**
- You must maintain this machine per the maintenance schedule in the operator manual. Remember before adjusting, servicing, or fueling this machine, disconnect the source of power to the machine by disconnecting the spark plug (Gas models), or by unplugging the electrical power cord (electric models) or air hose (Pneumatic models) AT THE MACHINE so you can assure yourself it remains unplugged while you are working on it. Do not modify this machine. Use only genuine EDCO parts and accessories. Repairs and service should be performed by approved EDCO dealers or authorized technicians.
- You should look carefully around the area before you begin work so you can identify potential hazards such as deck inserts, pipes, columns, openings, electrical cords or outlets, or any other objects protruding from the slab surface.
- This machine has no brain so you must use your own. There is no substitute for safety. The safety decals on the machine are to serve as a reminder for information you must already know before you begin using this machine. Take a moment to reread the safety decals each time you use the machine. If your machine is missing any decals, contact Discount-equipment for a replacement.

PARTS LIST MANUAL

MODEL TS-8 TILE SHARK™

Section	Page Number
Safety Messages and General Instructions	2
How To Order Replacement Parts	3
Illustration 1: Main Frame Grouping	4
Parts Listing - Illustration 1: Main Frame Grouping	5
Illustration 2: Motor Grouping	6
Parts Listing - Illustration 2: Motor Grouping	7
Limited Equipment Warranty	back cover

Go to Discount-Equipment.com to order your parts



ILLUSTRATION 1: MAIN FRAME GROUPING

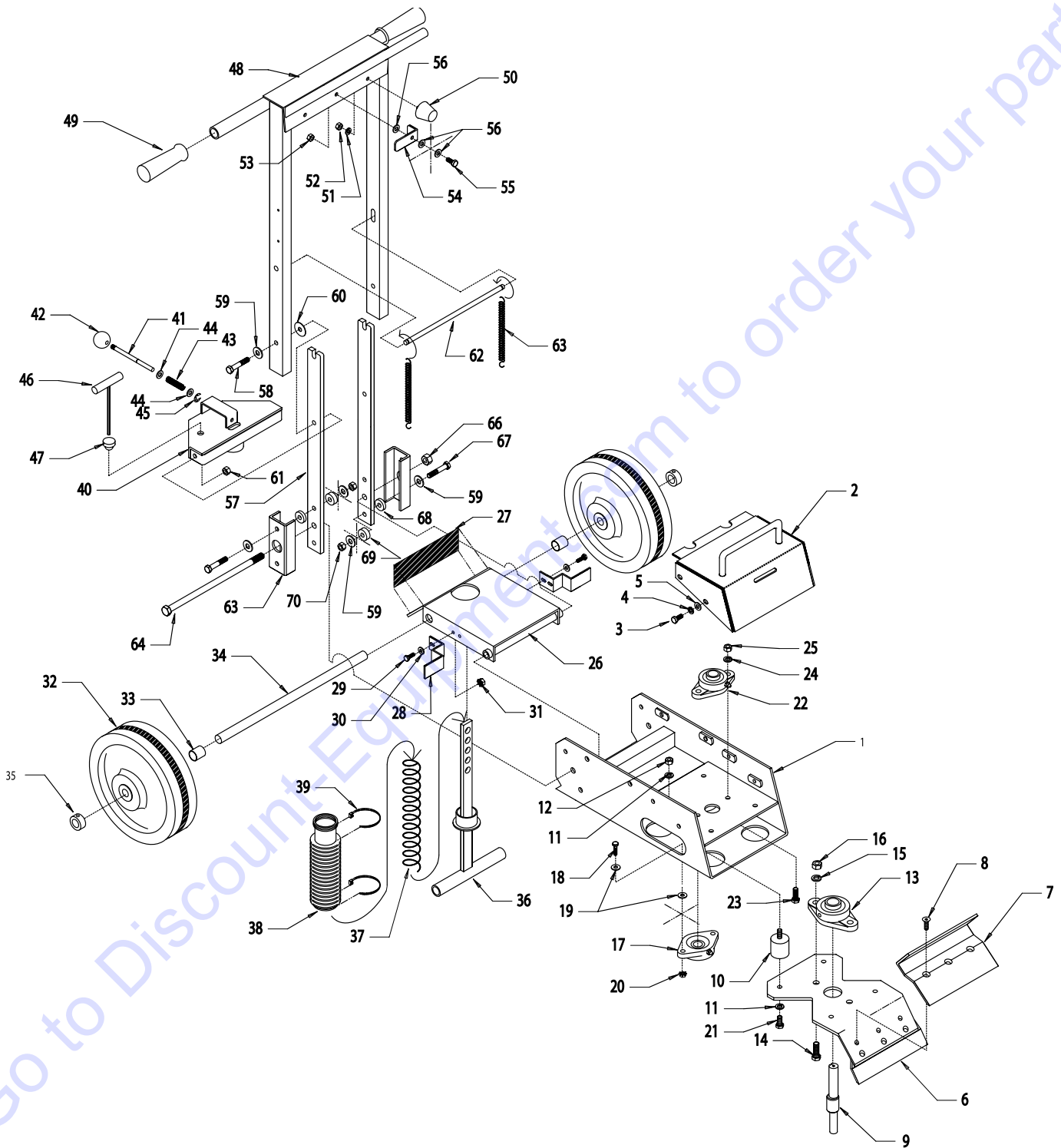

PARTS LISTING - ILLUSTRATION 1: MAIN FRAME GROUPING

ITEM #	PART #	DESCRIPTION	QTY.	ITEM #	PART #	DESCRIPTION	QTY.
1	28101	MAIN FRAME	1	35	10428	COLLAR, LOCKING 3/4 ID.	2
2	28102	HOOD	1	36	28106	ADJUSTMENT BAR, ANGLE	1
3	10053	SCREW, CAP 5/16-18 x 3/4	4	37	28107	SPRING, COMP., 1.468"OD x 11"FL	1
4	10801	WASHER, LOCK 5/16	4	38	24761	BELLOWS 1-3/4 ID x 10-1/4 LG.	1
5	10213	WASHER, FLAT 5/16	4	39	10982	TIE, CABLE, BLACK NYLON 11-1/4	2
6	28114	STRIKER PLATE	1	40	28108	LATCH SUPPORT	1
7	28120	RETAINER, SCRAPER BLADE	1	41	28123	PIN, PLUNGER	1
8	11682	SCREW, SKT. FLAT HEAD 5/16-18 x 1	3	42	10920	KNOB, BALL 1-3/8 w/ 5/16-24 THD.	1
9	28116	CAM SHAFT, STRIKER PLATE	1	43	28124	SPRING, COMP., .484 OD x 1.88 FL	1
10	28115	MOUNT, FLEX-BOLT SANDWICH	4	44	10213	WASHER, FLAT 5/16	2
11	10811	WASHER, LOCK 3/8	8	45	10137	RETAINING RING, E-CLIP 5/16	1
12	10404	NUT 3/8-16	4	46	28132	HEX KEY WRENCH 3/16 T-HANDLE	1
13	62022	BEARING, BALL 1" 2-HOLE FLANGE	1	47	28122	RUBBER PLUG, HEX KEY WRENCH	1
14	10003	SCREW, CAP 7/16-20 x 1-1/4	2	48	28109	HANDLE BAR	1
15	10450	WASHER, LOCK 7/16	2	49	10608	HAND GRIP 1" MODEL AT	2
16	10481	NUT, REG. 7/16-20	2	50	10931	MOUNT, TAPERED RUBBER 5/16-18	2
17	80009G	BEARING, BALL 5/8 2-HOLE FLANGE	1	51	10801	WASHER, LOCK 5/16	2
18	10031	SCREW, CAP 1/4-20 x 1	2	52	10054	NUT 5/16-18	1
19	10602	WASHER, FLAT 1/4	3	53	10807	NUT, LOCK 5/16-18	2
20	10861	NUT, KEPS 1/4-20	2	54	28125	LATCH, HANDLE HOLD-DOWN	1
21	10907	SCREW, CAP 3/8-16 x 3/4	4	55	10053	SCREW, CAP 5/16-18 x 3/4	1
22	50049	BEARING, BALL 3/4" 2-HOLE FLANGE	1	56	10213	WASHER, FLAT 5/16 SAE	3
23	10021	SCREW, CAP 3/8-24 x 1	2	57	28117	HANDLE BAR, LOWER LEG	2
24	10811	WASHER, LOCK 3/8	2	58	10336	SCREW, CAP 3/8-24 x 2-1/4	2
25	10014	NUT, 3/8-24	2	59	10025	WASHER, FLAT 3/8	11
26	28103	FORK	1	60	28133	WASHER, FLAT 13/32 x 1-1/4 x .047	2
27	28134	TREAD, ABRASIVE 2-1/4 x 7-1/2	1	61	10004	NUT, LOCK 3/8-24	2
28	28126	WIPER, WHEEL	2	62	28118	ROD, HANDLE SPRING	1
29	10018	SCREW, CAP 1/4-20 x 3/4	4	63	3636	SPRING, EXT. 6" L ("A" ADAPTER)	2
30	10602	WASHER, FLAT 1/4 SAE	4	64	28110	HANDLE BAR MOUNTING BRACKET	2
31	10861	NUT, KEPS 1/4-20	4	65	10355	SCREW, CAP 1/2-13 x 11	1
32	28129	WHEEL, PHENOLIC 10 x 2-1/2 x 3/4 BRG.	2	66	10407	NUT, LOCK 1/2-13	1
33	28105	WHEEL SPACER 13/16 ID x 15/16 OD x 1"L	2	67	10030	SCREW, CAP 3/8-24 x 2	4
34	28104	AXLE SHAFT 3/4 DIA. x 17"L	1	68	56018	BUSHING, RUBBER 1"OD x 3/8" ID x 1/4	4
				69	40329	BUSHING, RUBBER 1"OD x 3/8" ID x 3/8	4
				70	10004	NUT, LOCK 3/8-24	4

ITEMS
8 & 46
SELECT
HERE



ILLUSTRATION 2: MOTOR GROUPING

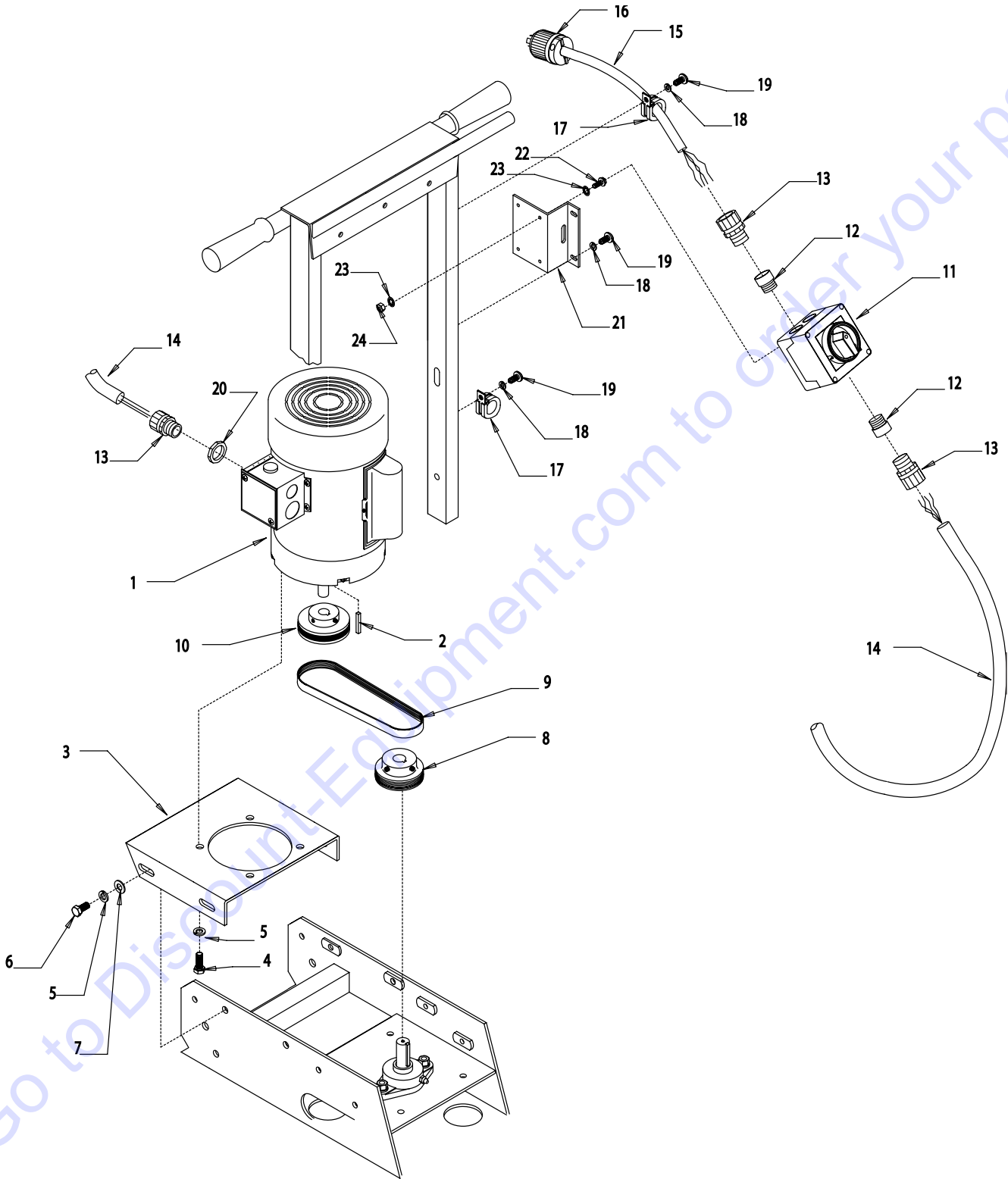

PARTS LISTING - ILLUSTRATION 2: MOTOR GROUPING			
ITEM #	PART #	DESCRIPTION	QTY.
1	16045	MOTOR,LEESON .75HP 1PH 1725RPM 115/208-230V, 10.8/5.4 FLA	1
2	~~~~	KEY, INCL. w/ MOTOR	1
3	28111	MOUNT, MOTOR	1
4	10907	SCREW, CAP 3/8-16 x 3/4	4
5	10811	WASHER, LOCK 3/8	4
6	10907	SCREW, CAP 3/8-16 x 3/4	4
7	10025	WASHER, FLAT 3/8	4
8	28130	SHEAVE 2.80" OD x 6Gr.J x 3/4 BORE	1
9	28113	BELT 220J 6-GROOVE	1
10	28131	SHEAVE 3.0" OD x 6Gr.J x 5/8 BORE	1
11	77043	SWITCH, ROTARY CAM ON/OFF, LOVATO	1
12	~~~~	ADAPTER (INCL. w/ SWITCH)	2
13	41130	STRAIN RELIEF 1/2 NPT x .550-.650	3
14	28135	WIRE, HARNESS 12/3 SWITCH/MOTOR	1
15	28136	WIRE HARNESS 12/3 SWITCH/PLUG	1
16	78114	PLUG, STRAIGHT 15A/125V	1
17	11565	CLAMP, LOOM 5/8 (SAE SIZE 10)	2
18	10038	WASHER, LOCK 1/4	4
19	10846	SCREW, CAP STSHW 1/4-20 x 1/2	4
20	10790	CONDUIT LOCK NUT 1/2 NP	1
21	77042	BRACKET, SWITCH BOX, LOVATO	1
22	11663	SCREW, MACHINE 8-32 x 1/2	4
23	10461	WASHER, LOCK, INT. TOOTH # 8	4
24	10462	NUT 8-32	4

PARTS FINDER

**Search Website
by Part Number**



**Search Manual
Library For Parts
Manual & Lookup Part
Numbers – Purchase
or Request Quote**

Search Manuals

Enter your information to help us find the right parts manual for your machine.

* Brand:

* Model:

* Serial:

* Part Number:

SEARCH

**Can't Find Part or
Manual? Request Help
by Manufacturer,
Model & Description**

Parts Order Form

Please fill in the following information to help us find the right part for your machine.

Manufacturer:	<input type="text"/>
Model:	<input type="text"/>
Description:	<input type="text"/>
Part Number:	<input type="text"/>
Quantity:	<input type="text"/>
Notes:	<input type="text"/>

Discount-Equipment.com is your online resource for quality parts & equipment.

Florida: **561-964-4949** Outside Florida TOLL FREE: **877-690-3101**

Need parts?

Click on this link: <http://www.discount-equipment.com/category/5443-parts/> and choose one of the options to help get the right parts and equipment you are looking for. Please have the machine model and serial number available in order to help us get you the correct parts. If you don't find the part on the website or on one of the online manuals, please fill out the request form and one of our experienced staff members will get back to you with a quote for the right part that your machine needs.

We sell worldwide for the brands: Genie, Terex, JLG, MultiQuip, Mikasa, Essick, Whiteman, Mayco, Toro Stone, Diamond Products, Generac Magnum, Airman, Haulotte, Barreto, Power Blanket, Nifty Lift, Atlas Copco, Chicago Pneumatic, Allmand, Miller Curber, Skyjack, Lull, Skytrak, Tsurumi, Husquvarna Target, Stow, Wacker, Sakai, Mi-T-M, Sullair, Basic, Dynapac, MBW, Weber, Bartell, Bennar Newman, Haulotte, Ditch Runner, Menegotti, Morrison, Contec, Buddy, Crown, Edco, Wyco, Bomag, Laymor, EZ Trench, Bil-Jax, F.S. Curtis, Gehl Pavers, Heli, Honda, ICS/PowerGrit, IHI, Partner, Imer, Clipper, MMD, Koshin, Rice, CH&E, General Equipment, Amida, Coleman, NAC, Gradall, Square Shooter, Kent, Stanley, Tamco, Toku, Hatz, Kohler, Robin, Wisconsin, Northrock, Oztec, Toker TK, Rol-Air, APT, Wylie, Ingersoll Rand / Doosan, Innovatech, Con X, Ammann, Mecalac, Makinex, Smith Surface Prep, Small Line, Wanco, Yanmar