

PORTABLE HYDRAULIC POWER UNIT

MODEL HT20G / HT20GV

This power unit features a Honda 24 HP OHV gas engine, extended run fuel tank, extra oil cooling and easy handling. Great for continuous duty applications powering our pumps or other hydraulic tools and equipment.



FEATURES

- Reliable Honda OHV Gas Engine with Electric Start and Low Oil Shut-Down
 - Roll Cage Frame with Wheel Kit
 - 15 Gallon Built-in Fuel Tank
 - Single Point Lifting Bracket
 - Gear Type Hydraulic Pump
 - Pressure Control Valve
 - System Relief Valve
 - Efficient Oil Cooler with Thermostatic Fan Control
 - Fluid Level Gauges
 - Liquid Filled Pressure Gauge
 - Spin-On 10 Micron Return Filter
- OPTIONS:**
- Optional Pressure Compensated Piston Hydraulic Pump (HT20GV model)
 - For Flows and Pressures Other Than Standard, Consult Factory

C0701

Model HT20G/GV Overall Dimensions

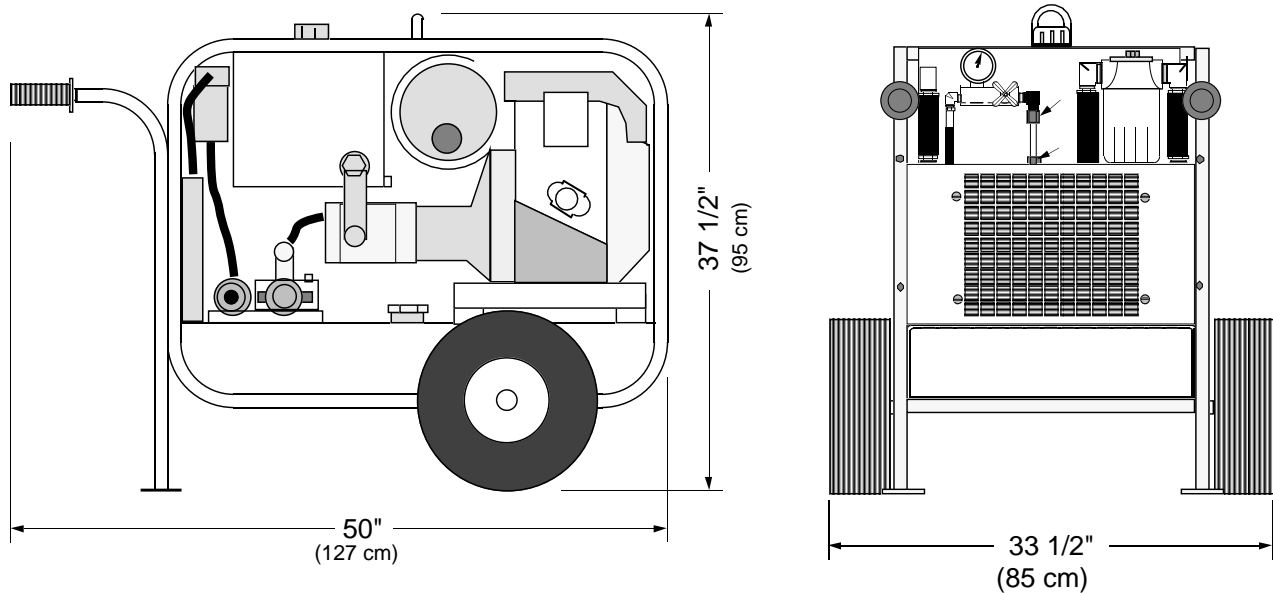

SPECIFICATIONS

ENGINE:..... Honda GX670 Gasoline
HORSEPOWER:..... 24 @ 3500 RPM
HYDRAULIC OUTPUT:..... Variable, Max. 12 GPM (45 LPM)
OPERATING PRESSURE:..... Maximum 2500 PSI (170 Bar)
HOSE PORT SIZE:..... 3/4" NPT
HYDRAULIC OIL:..... SAE 10W or 20W Type AW
also: Dexron ATF or Bio-degradeable Oil (Consult Factory)
OIL FILTRATION:..... 10 Micron (Standard)
OIL RESERVOIR CAPACITY:..... 8 Gallons (30 Liters)
FUEL TANK CAPACITY:..... 15 Gallons (57 Liters)
FUEL CONSUMPTION:..... Approx. 1.5 Gal/Hr (5.7 Liters/Hr)
DIMENSIONS:....H 37 1/2" (95 cm) x W 33 1/2" (85 cm) x L 50" (127 cm)
WEIGHT (Dry):..... 450lbs. (204 kg)

Since we are constantly working to improve our products, specifications are subject to change without notice.