



PARTS LIST MANUAL
Model CD-5



5-Head Air Powered Scabbler
Part No. 63100

PARTS FINDER

**Search Website
by Part Number**



**Search Manual
Library For Parts
Manual & Lookup Part
Numbers – Purchase
or Request Quote**

Search Manuals

Enter your information to help us find the right parts manual for your machine.

* Brand:

* Model:

* Serial:

* Part Number:

SEARCH

**Can't Find Part or
Manual? Request Help
by Manufacturer,
Model & Description**

Parts Order Form

Please fill in the following information to help us find the right part for your machine.

Manufacturer:	<input type="text"/>
Model:	<input type="text"/>
Description:	<input type="text"/>
Part Number:	<input type="text"/>
Quantity:	<input type="text"/>
Notes:	<input type="text"/>

Submit

Discount-Equipment.com is your online resource for quality parts & equipment.

Florida: **561-964-4949** Outside Florida TOLL FREE: **877-690-3101**

Need parts?

Click on this link: <http://www.discount-equipment.com/category/5443-parts/> and choose one of the options to help get the right parts and equipment you are looking for. Please have the machine model and serial number available in order to help us get you the correct parts. If you don't find the part on the website or on one of the online manuals, please fill out the request form and one of our experienced staff members will get back to you with a quote for the right part that your machine needs.

We sell worldwide for the brands: Genie, Terex, JLG, MultiQuip, Mikasa, Essick, Whiteman, Mayco, Toro Stone, Diamond Products, Generac Magnum, Airman, Haulotte, Barreto, Power Blanket, Nifty Lift, Atlas Copco, Chicago Pneumatic, Allmand, Miller Curber, Skyjack, Lull, Skytrak, Tsurumi, Husquvarna Target, Stow, Wacker, Sakai, Mi-T-M, Sullair, Basic, Dynapac, MBW, Weber, Bartell, Bennar Newman, Haulotte, Ditch Runner, Menegotti, Morrison, Contec, Buddy, Crown, Edco, Wyco, Bomag, Laymor, EZ Trench, Bil-Jax, F.S. Curtis, Gehl Pavers, Heli, Honda, ICS/PowerGrit, IHI, Partner, Imer, Clipper, MMD, Koshin, Rice, CH&E, General Equipment, Amida, Coleman, NAC, Gradall, Square Shooter, Kent, Stanley, Tamco, Toku, Hatz, Kohler, Robin, Wisconsin, Northrock, Oztec, Toker TK, Rol-Air, APT, Wylie, Ingersoll Rand / Doosan, Innovatech, Con X, Ammann, Mecalac, Makinex, Smith Surface Prep, Small Line, Wanco, Yanmar

READ AND UNDERSTAND THE OPERATOR'S INSTRUCTION MANUAL *THOROUGHLY* BEFORE ATTEMPTING TO OPERATE THIS EQUIPMENT.



Death or serious injury could occur if this equipment is used improperly.



SAFETY MESSAGES

- Safety Instructions are preceded by a graphic alert symbol of DANGER, WARNING, or CAUTION.



Indicates an imminent hazard which, if not avoided, will result in death or serious injury.



Indicates an imminent hazard which, if not avoided, can result in death or serious injury.



Indicates hazards which, if not avoided, could result in serious injury and or damage to the equipment.

AIR POWERED EQUIPMENT



- When operating this equipment, the operator must wear approved job related safety attire. Eye and hearing protection must be worn at all times while equipment is in use as sound levels exceed 85 dBA. Steel toe safety shoes should be worn. Head protection is required if work is performed overhead. Wear proper dust mask based on material being removed.
- Use the correct size air hose for the tool, 1/2" diameter (minimum). Hose and fittings must be rated for safe handling in excess of 100 PSI pressure. The working pressure of this tool is 80-90 PSI and should never be allowed to exceed 100 PSI.
- Limit the hose length to 30 feet (10 meters) maximum.
Note: The pressure drop of 1/2" diameter hose is approximately 1 PSI per 90 linear feet.
- Limit the hose length to 30 feet (10 meters) maximum.
Note: The pressure drop of 3/8" diameter hose is approximately 3 PSI per 90 linear feet.
- A filter/water separator must be provided on the air source to afford an adequate supply of clean, dry air to this machine.



- Disconnect the air supply before performing any maintenance on this machine. Use only genuine EDCO parts with this equipment. Failure to do so may result in serious bodily injury or death.

- Replace any damaged parts immediately. Use only genuine EDCO parts.

AIR POWERED EQUIPMENT CONTINUED

- To activate machine, attach the air source, firmly grip the machine and then turn the hand lever on the air valve on.

- After turning the air valve hand lever off, the tool will continue to operate for a few seconds. This is a normal result of stored up pressure in the machine casing being released gradually. **Be sure to firmly grip the machine until ALL air leaves the chamber.**

- Remove the air source from the machine when not in use.

- This equipment will create dust from the material being removed. **WARNING** That dust may contain a chemical known to the state of California to cause cancer and/or birth defects or other reproductive harm. Check the chemical properties of the materials to be removed.

- **CAUTION** It is the operator's responsibility to keep other people (workers, pedestrians, bystanders, etc.) away during operation. Block off the work area in all directions with roping, safety netting, etc. for a safe distance. Failure to do so may result in others being injured by flying debris or exposing them to harmful dust and noise.

DUST WARNING

Some dust created by power sanding, sawing, grinding, drilling, and other construction activities contains chemicals known to cause cancer, birth defects, or other reproductive harm. Some examples of these chemicals are:

- Lead from lead-based paints, and
- Crystalline silica from bricks and concrete and other masonry products.

Your risk of exposure to these chemicals varies depending on how often you do this type of work. To reduce your risk: work in a well ventilated area, use a dust control system, such as an industrial-style vacuum, and wear approved personal safety equipment, such as dust/particle respirator designed to filter out microscopic particles.

OPERATOR RESPONSIBILITIES

- Read and follow all safety decals and labels.
- Maintain a safe operating distance to other personnel.
- Be familiar with all aspects of the machine's operation and controls before applying power to the equipment.
- Use the correct accessory for the job being performed and material being removed. Make sure accessories are mounted correctly.
- Never operate this machine while under the influence of drugs or alcohol, while taking medications that impair the senses or reactions, or when excessively tired or under stress.
- Follow the instructions in the operator's manual and exercise caution.
- Comply with all local safety and health regulations as well as EPA and OSHA regulations.
- Maintain a copy of the equipment's operator's manual with the machine for reference at all times.

PARTS LIST MANUAL

MODEL CD-5

5-HEAD SCABBLER

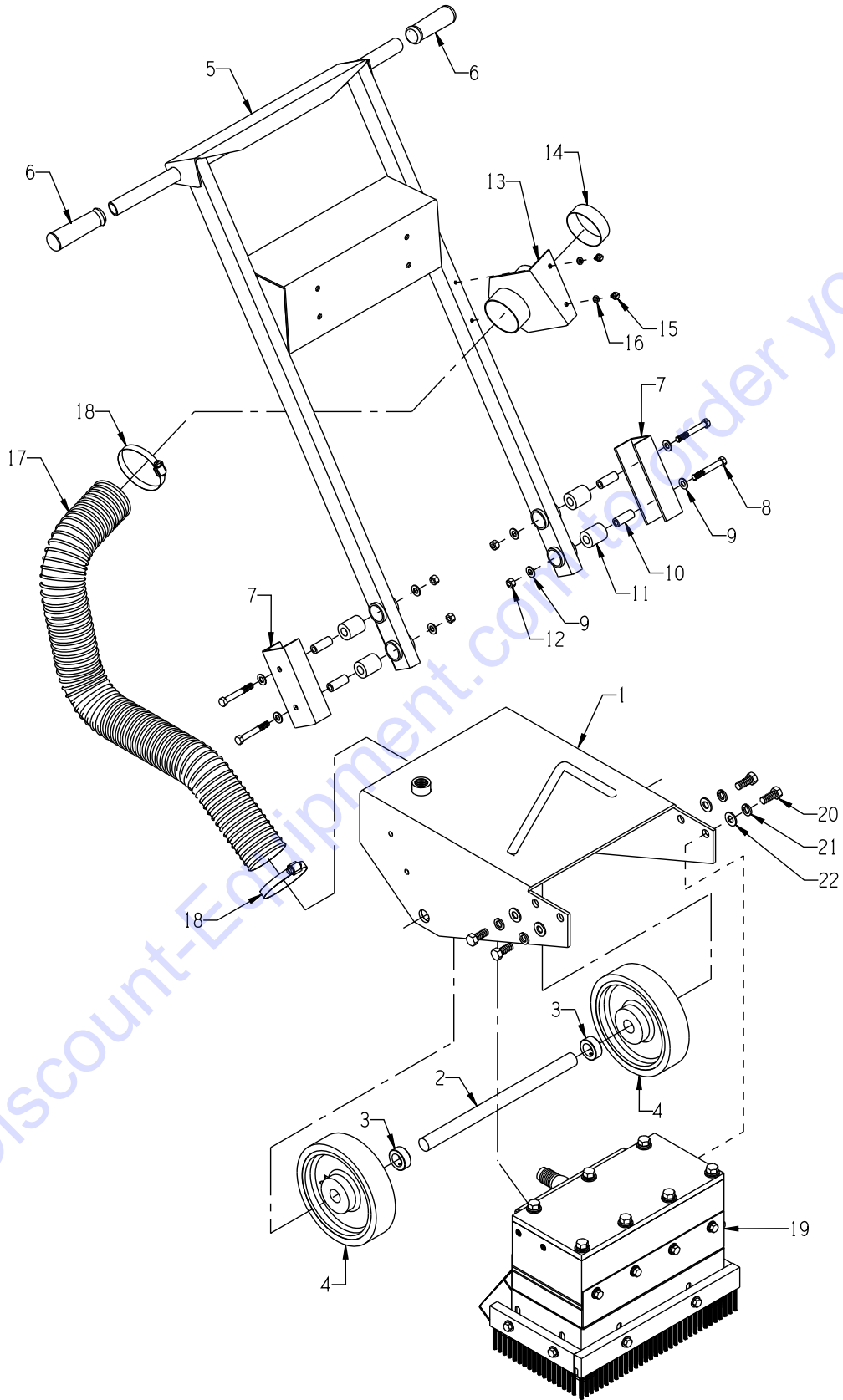
TABLE OF CONTENTS

<u>Section</u>	<u>Page Number</u>
Safety Messages and General Instructions	2
How To Order Replacement Parts	3
Illustration 1: Main Assembly	4, 5
Illustration 2: Lubricator and Air Hose Grouping	6, 7
Illustration 3: Cylinder Block Grouping	8, 9
Illustration 4: Piston & Cylinder Assembly	10
Illustration 5: Scabblers Accessories	11
Decal Sheet	12
Notes	13
Limited Equipment Warranty of Sale	16

Go to Discount-Equipment.com to order your parts

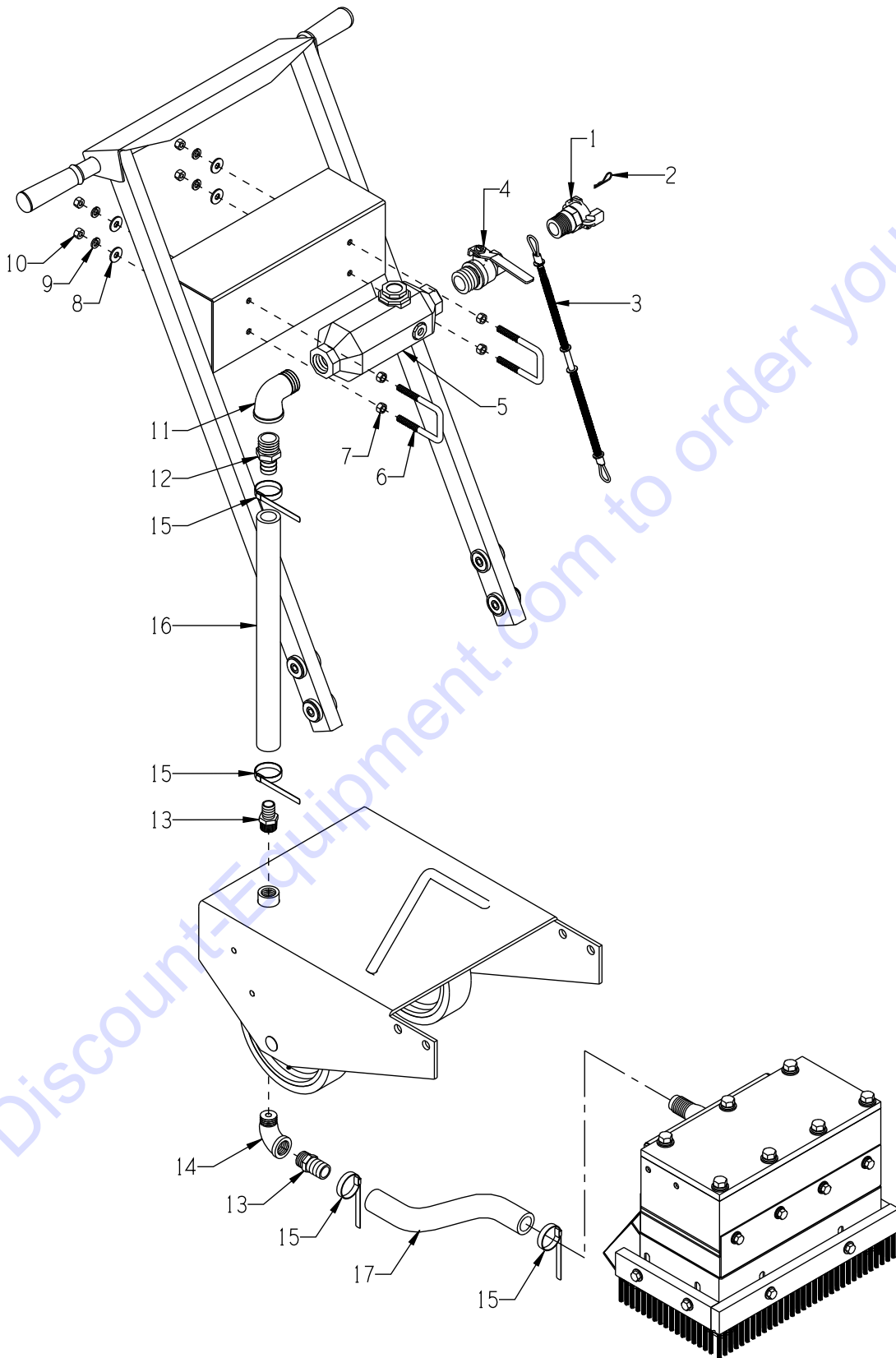


ILLUSTRATION 1: MAIN GROUPING



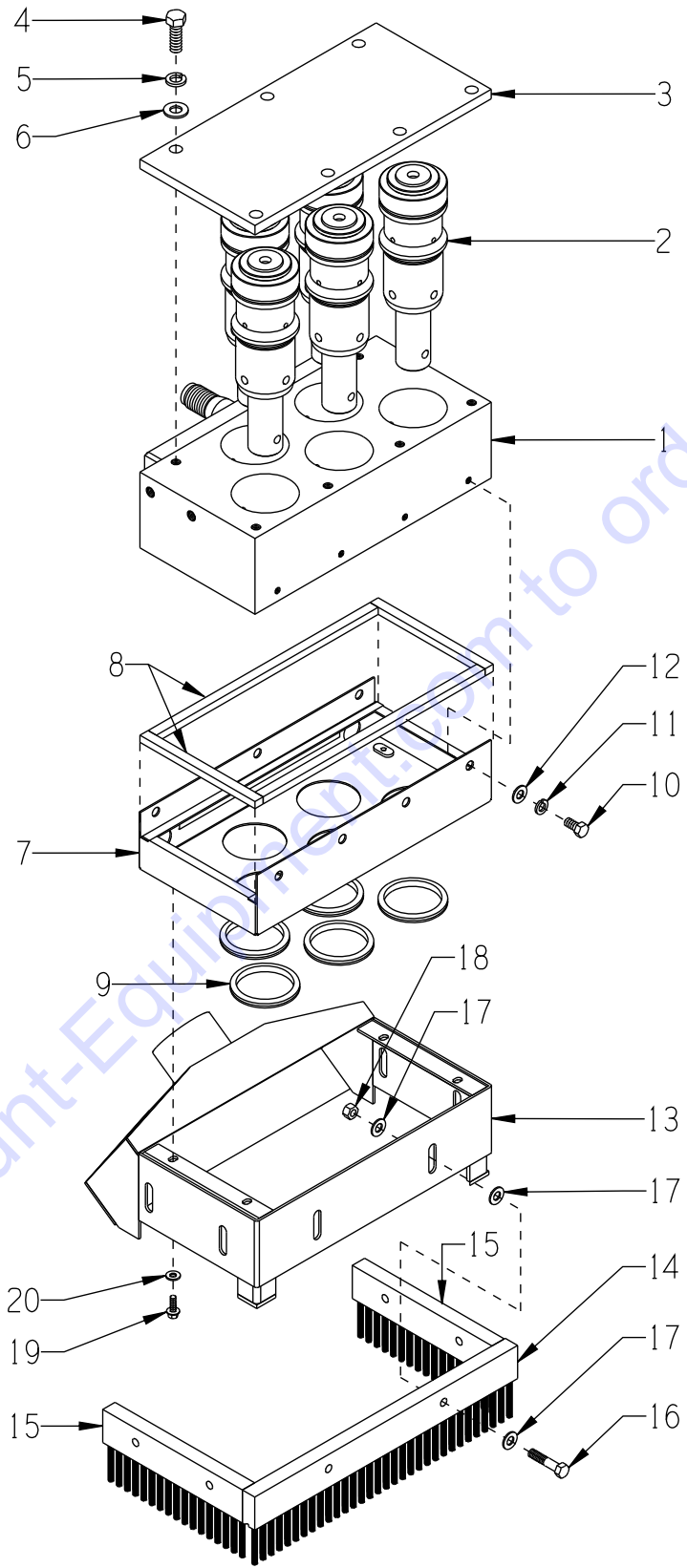
PARTS LISTING - ILLUSTRATION 1: MAIN GROUPING			
ITEM #	PART #	DESCRIPTION	QTY.
1	63101	MAIN FRAME, CD-5	1
2	63053	AXLE SHAFT 1"DIA. X 15"L, CD-5	1
3	10427	COLLAR, LOCKING 1"ID	2
4	63050	WHEEL 8 X 1-15/16 X 1"BRG., POLY	2
5	63151	HANDLE BAR, CD-5	1
6	10608	GRIP, HAND 1" MODEL AT	2
7	63105	BRACKET, HANDLE BAR MOUNTING, CD-5	2
8	10815	SCREW, CAP 3/8-24 X 2-3/4	4
9	10025	WASHER, FLAT 3/8 SAE ZINC	8
10	63107	TUBE, BUSHING CENTER, CD-5 5/8 X 3/8 X 1-9/16	4
11	63106	BUSHING, RUBBER 1-1/4 X 5/8 X 1-5/8	4
12	10004	NUT, HEX LOCK 3/8-24 ZINC	4
13	63112	BRACKET, VACUUM HOSE 3"	1
14	64030	CAP, END 3" BLUE PLASTIC	1
15	10846	SCREW, CAP STSHW 1/4-20 X 1/2	2
16	10038	WASHER, LOCK 1/4 ZINC	2
17	63130	HOSE, FLEX 3"ID X 36"L, CD-5	1
18	10849	CLAMP, HOSE, SAE #52, ADJ. TO 3-3/4	2
19	-----	CYLINDER BLOCK ASSEMBLY (REFER TO ILLUS. 3 FOR BREAKDOWN)	1
20	11672	SCREW, CAP 1/2-13 X 1-1/4	4
21	10045	WASHER, LOCK 1/2 ZINC	4
22	10312	WASHER, FLAT 1/2 SAE ZINC	4

ILLUSTRATION 2: LUBRICATOR & AIR HOSE GROUPING



PARTS LISTING - ILLUSTRATION 2: LUBRICATOR & AIR HOSE GROUPING			
ITEM #	PART #	DESCRIPTION	QTY.
1	63129	COUPLER, AIR HOSE, 1"MPT	1
2	61066	PIN, HAIR COTTER .080" X 1-9/16"OAL	1
3	63040	CABLE, WHIPCHEK SAFETY 1/8 X 20-1/4	1
4	63128	VALVE, BALL 1"FPT X 1"MPT, CD-5	1
5	63150	LUBRICATOR, 1 PINT, 1"NPT, CD-5	1
6	63214	U-BOLT, SQ. BEND 3/8-16 X 2 X 5	2
7	-----	NUT, HEX 3/8-16 (INCLUDED W/ U-BOLT)	4
8	-----	WASHER, FLAT 3/8 (INCLUDED W/ U-BOLT)	4
9	10811	WASHER, LOCK 3/8 ZINC	4
10	10404	NUT, HEX 3/8-16 ZINC	4
11	50083	ELBOW, STREET 1"NPT X 90 (BLACK)	1
12	63127	BARB, 1"HOSE X 1"MPT (BRASS)	1
13	63047	BARB, 1"HOSE X 3/4MPT (BRASS)	2
14	10727	ELBOW, STREET 3/4NPT X 90 (BLACK)	1
15	63071	CLAMP, HOSE 1-3/8"ID X 3/8"W X .025	4
16	63120	HOSE, AIR 1"ID X 17-5/8"L, CD-5	1
17	63119	HOSE, AIR 1"ID X 11-1/4"L, CD-5	1

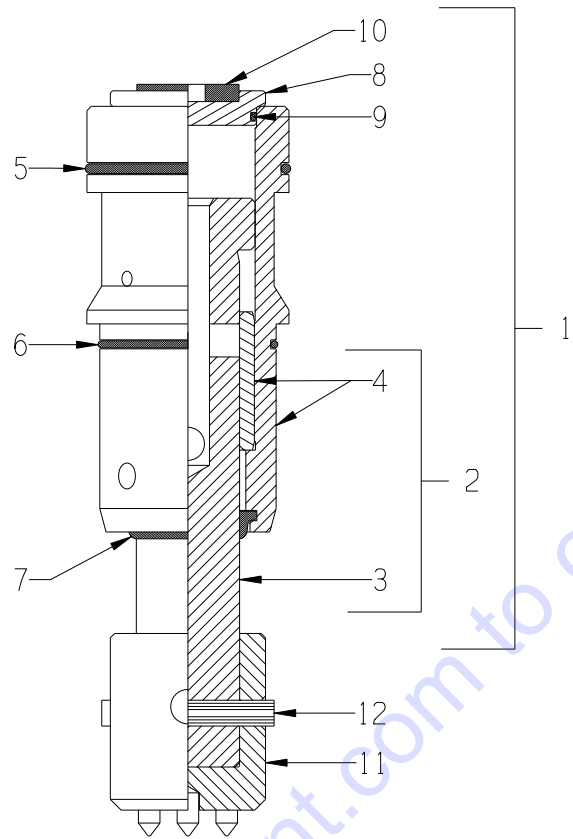
ILLUSTRATION 3: CYLINDER BLOCK GROUPING



Go to Discount-Equipment.com to order your parts

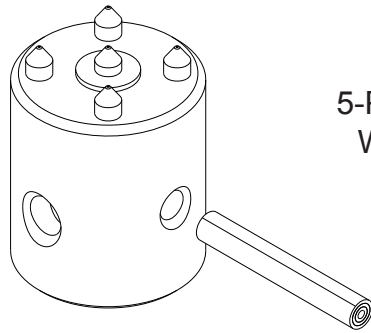
PARTS LISTING - ILLUSTRATION 3: CYLINDER BLOCK GROUPING			
ITEM #	PART #	DESCRIPTION	QTY.
1	63024	BLOCK WELDMENT, CYLINDER, CD-5	1
2	63010	PISTON & CYLINDER ASSEMBLY, CD-3/5	5
3	63023	PLATE, CYLINDER BLOCK TOP, CD-5	1
4	10356	SCREW, CAP 1/2-13 X 1-1/2	7
5	10045	WASHER, LOCK 1/2 ZINC	7
6	10312	WASHER, FLAT 1/2 SAE ZINC	7
7	63102	EXHAUST BOX, CD-5	1
8	63026	SEALING STRIPS, EXHAUST BOX 1/2"W X 3/8"THK X 7"L (2 REQ'D.) 1/2"W X 3/8"THK X 13-1/2"L (2 REQ'D.)	1 SET
9	63110	GROMMET 2-1/2ID X 1/16GRV.X 2-3/4GD	5
10	10907	SCREW, CAP 3/8-16 X 3/4	7
11	10811	WASHER, LOCK 3/8 ZINC	7
12	10025	WASHER, FLAT 3/8 SAE ZINC	7
13	63103	SKIRT, 3"VACUUM, CD-5	1
14	63113	BRUSH SEAL, 2"H X 16"L, CD-5	1
15	63114	BRUSH SEAL, 2"H X 8-1/2"L, CD-5	2
16	10029	SCREW, CAP 3/8-24 X 1-3/4	6
17	10025	WASHER, FLAT 3/8 SAE ZINC	18
18	10152	NUT, HEX NYLON LOCK 3/8-24 ZINC	6
19	11811	BOLT, FLANGE 1/4-20 X 3/4 ZINC	4
20	10602	WASHER, FLAT 1/4 SAE ZINC	4

ILLUSTRATION 4: PISTON & CYLINDER ASSEMBLY

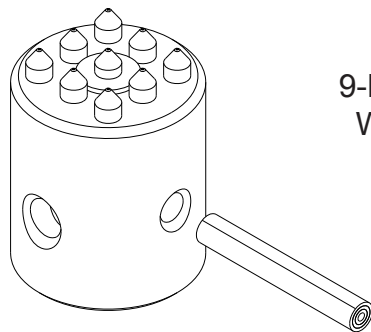


ITEM #	PART #	DESCRIPTION	QTY.*
1	63010	PISTON & CYLINDER ASSY. (ITEMS 2 - 10)	5
2	63010S	PISTON & CYLINDER SET (ITEMS 3 & 4)	1
3	63018	PISTON	1
4	63070	CYLINDER & LINER ASSEMBLY	1
5	63016	O-RING #231, 1/8 X 2-5/8"ID	1
6	63017	O-RING #141, 3/32 X 2-5/16"ID	1
7	63019	WIPER RING, PISTON	1
8	63012	CAP, CYLINDER TOP	1
9	63013	O-RING #133, 3/32 X 1-13/16"ID	1
10	63011	INSERT, TOP CAP	1
11	18810 18820	TUNGSTEN CARBIDE BIT W/ PIN (ITEM 12) UNIVERSAL BIT W/ PIN, 5-POINT UNIVERSAL BIT W/ PIN, 9-POINT	1
12	63056	PIN, H.D. COILED SPRING 3/8 X 2-1/2 (INCLUDED W/ ITEM 11)	1
<p>*NOTE: THERE ARE 5 TOTAL ASSEMBLIES (ITEM 1) PER SCABBLER. QUANTITIES FOR ITEMS 2 THRU 10 ARE BASED ON 1 ASSEMBLY. ITEMS 11 & 12 ARE NOT INCLUDED WITH THE 63010 ASSEMBLY.</p>			

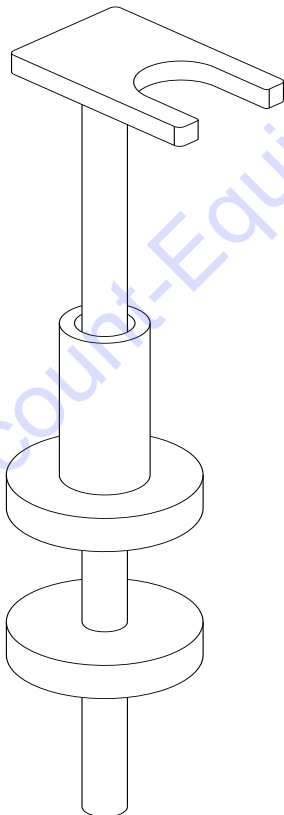
ILLUSTRATION 5: SCABBLER ACCESSORIES



5-POINT TUNGSTEN CARBIDE BIT
WITH H.D. COILED SPRING PIN
PART # 18810
5 REQUIRED



9-POINT TUNGSTEN CARBIDE BIT
WITH H.D. COILED SPRING PIN
PART # 18820
5 REQUIRED



BIT REMOVING TOOL
(SLIDE HAMMER)
PART # 63220

OPTIONAL
(NOT INCLUDED WITH SCABBLER)

PARTS FINDER

**Search Website
by Part Number**



**Search Manual
Library For Parts
Manual & Lookup Part
Numbers – Purchase
or Request Quote**

Search Manuals

Enter your information to help us find the right parts manual for your machine.

* Brand:

* Model:

* Serial:

* Part Number:

SEARCH

**Can't Find Part or
Manual? Request Help
by Manufacturer,
Model & Description**

Parts Order Form

Please fill in the following information to help us find the right part for your machine.

Manufacturer:	<input type="text"/>
Model:	<input type="text"/>
Description:	<input type="text"/>
Part Number:	<input type="text"/>
Quantity:	<input type="text"/>
Notes:	<input type="text"/>

Submit

Discount-Equipment.com is your online resource for quality parts & equipment.

Florida: **561-964-4949** Outside Florida TOLL FREE: **877-690-3101**

Need parts?

Click on this link: <http://www.discount-equipment.com/category/5443-parts/> and choose one of the options to help get the right parts and equipment you are looking for. Please have the machine model and serial number available in order to help us get you the correct parts. If you don't find the part on the website or on one of the online manuals, please fill out the request form and one of our experienced staff members will get back to you with a quote for the right part that your machine needs.

We sell worldwide for the brands: Genie, Terex, JLG, MultiQuip, Mikasa, Essick, Whiteman, Mayco, Toro Stone, Diamond Products, Generac Magnum, Airman, Haulotte, Barreto, Power Blanket, Nifty Lift, Atlas Copco, Chicago Pneumatic, Allmand, Miller Curber, Skyjack, Lull, Skytrak, Tsurumi, Husquvarna Target, Stow, Wacker, Sakai, Mi-T-M, Sullair, Basic, Dynapac, MBW, Weber, Bartell, Bennar Newman, Haulotte, Ditch Runner, Menegotti, Morrison, Contec, Buddy, Crown, Edco, Wyco, Bomag, Laymor, EZ Trench, Bil-Jax, F.S. Curtis, Gehl Pavers, Heli, Honda, ICS/PowerGrit, IHI, Partner, Imer, Clipper, MMD, Koshin, Rice, CH&E, General Equipment, Amida, Coleman, NAC, Gradall, Square Shooter, Kent, Stanley, Tamco, Toku, Hatz, Kohler, Robin, Wisconsin, Northrock, Oztec, Toker TK, Rol-Air, APT, Wylie, Ingersoll Rand / Doosan, Innovatech, Con X, Ammann, Mecalac, Makinex, Smith Surface Prep, Small Line, Wanco, Yanmar