

STARTING SERIAL NO. 061110003



**PARTS LIST MANUAL**

**Model CD-3**



**3-Head Chip-Dek Scabbler  
Part No. 63200**



# PARTS FINDER

**Search Website  
by Part Number**



**Search Manual  
Library For Parts  
Manual & Lookup Part  
Numbers – Purchase  
or Request Quote**

**Search Manuals**

Enter your information to help us find the right parts manual for your machine.

\* Brand:

\* Model:

\* Serial:

\* Part Number:

SEARCH

**Can't Find Part or  
Manual? Request Help  
by Manufacturer,  
Model & Description**

**Parts Order Form**

Please fill in the following information to help us find the right part for your machine.

Manufacturer:	<input type="text"/>
Model:	<input type="text"/>
Description:	<input type="text"/>
Part Number:	<input type="text"/>
Quantity:	<input type="text"/>
Notes:	<input type="text"/>

Submit

Discount-Equipment.com is your online resource for quality parts & equipment.

Florida: **561-964-4949** Outside Florida TOLL FREE: **877-690-3101**

**Need parts?**

Click on this link: <http://www.discount-equipment.com/category/5443-parts/> and choose one of the options to help get the right parts and equipment you are looking for. Please have the machine model and serial number available in order to help us get you the correct parts. If you don't find the part on the website or on one of the online manuals, please fill out the request form and one of our experienced staff members will get back to you with a quote for the right part that your machine needs.

We sell worldwide for the brands: Genie, Terex, JLG, MultiQuip, Mikasa, Essick, Whiteman, Mayco, Toro Stone, Diamond Products, Generac Magnum, Airman, Haulotte, Barreto, Power Blanket, Nifty Lift, Atlas Copco, Chicago Pneumatic, Allmand, Miller Curber, Skyjack, Lull, Skytrak, Tsurumi, Husquvarna Target, Stow, Wacker, Sakai, Mi-T-M, Sullair, Basic, Dynapac, MBW, Weber, Bartell, Bennar Newman, Haulotte, Ditch Runner, Menegotti, Morrison, Contec, Buddy, Crown, Edco, Wyco, Bomag, Laymor, EZ Trench, Bil-Jax, F.S. Curtis, Gehl Pavers, Heli, Honda, ICS/PowerGrit, IHI, Partner, Imer, Clipper, MMD, Koshin, Rice, CH&E, General Equipment, Amida, Coleman, NAC, Gradall, Square Shooter, Kent, Stanley, Tamco, Toku, Hatz, Kohler, Robin, Wisconsin, Northrock, Oztec, Toker TK, Rol-Air, APT, Wylie, Ingersoll Rand / Doosan, Innovatech, Con X, Ammann, Mecalac, Makinex, Smith Surface Prep, Small Line, Wanco, Yanmar

READ AND UNDERSTAND THE OPERATORS INSTRUCTION MANUAL THOROUGHLY BEFORE ATTEMPTING TO OPERATE THIS EQUIPMENT. Death or serious injury could occur if this machine is used improperly.



## SAFETY MESSAGES



The safety instructions are preceded by a graphic alert message of DANGER, WARNING, or CAUTION.



Indicates an imminent hazard which, if not avoided, will result in death or serious injury.



Indicates an imminent hazard which, if not avoided, can result in death or serious injury.



Indicates hazards which, if not avoided, could result in serious injury and or damage to the equipment.

## GASOLINE Powered Equipment



- Do not operate gasoline powered equipment without adequate ventilation. Carbon monoxide is an invisible, odorless gas that can kill.

## ELECTRICAL Powered Equipment



- ELECTRICAL HAZARD** - Be sure equipment is properly grounded. Failure to comply could kill or result in serious injury.



The engine exhaust from this product contains chemicals known to the State of California to cause cancer, birth defects or other reproductive harm.

## GENERAL INSTRUCTIONS



- You must read and understand the operators instruction manual and all other manuals associated with this machine. For your safety and the safety of others around you, it is extremely important to fully understand how to operate this machine in the way it was intended. Different model machines or older/newer versions of the same model may have different parts and controls that you need to understand. If instructions are not readable or available DO NOT USE this machine and contact Discount-equipment for a replacement Manual.
- You must be able to physically handle the bulk weight and power of this machine. If not properly controlled this machine can cause death or serious injury.
- Do not operate this machine in an impaired mental state. You must be able to exercise good judgement and reactions to maintain a safe working environment.
- This is a "one person" machine which means only one operator can be operating the machine at any one time. For the safety of others, maintain a safe operating distance to other personnel. Your work area should be defined and appropriately marked so bystanders and coworkers do not stand or walk near this machine and end up seriously injured by flying debris or exposing them to harmful noise or dust.
- This equipment is for Commercial use. Although this is a "one person" machine your work team should understand how to shut this machine off and quickly get medical help if an accident strikes the operator.
- Keep all guards in place during operation. The guards are to provide protection from inadvertent contact with dangerous moving parts, pinch points, or hot surfaces.
- Wear appropriate Personal Protective Equipment (PPE) including safety glasses, safety boots, work gloves, respiratory protection, hearing protection, and head protection. Do not wear loose clothing that can get tangled in moving parts. Failure to do so could result

in dismemberment or death. **Wear an approved respirator when removing hazardous materials or when grinding/cutting dry materials. Some dust particles such as concrete dust can contain silicate particles which can cause silicosis (a very serious lung disease). Contact NIOSH or OSHA for further details. When wet grinding/cutting, avoid contact with the concrete/asphalt slurry which can cause serious skin irritations.**

- You must maintain this machine per the maintenance schedule in the operator manual. Remember before adjusting, servicing, or fueling this machine, disconnect the source of power to the machine by disconnecting the spark plug (Gas models), or by unplugging the electrical power cord (electric models) or air hose (Pneumatic models) AT THE MACHINE so you can assure yourself it remains unplugged while you are working on it. Do not modify this machine. Use only genuine EDCO parts and accessories. Repairs and service should be performed by approved EDCO dealers or authorized technicians.
- You should look carefully around the area before you begin work so you can identify potential hazards such as deck inserts, pipes, columns, openings, electrical cords or outlets, or any other objects protruding from the slab surface.
- This machine has no brain so you must use your own. There is no substitute for safety. The safety decals on the machine are to serve as a reminder for information you must already know before you begin using this machine. Take a moment to reread the safety decals each time you use the machine. If your machine is missing any decals, contact Discount-equipment for a replacement.

# PARTS LIST MANUAL

## MODEL CD-3

<u>Section</u>	<u>Page Number</u>
Safety Messages and General Instructions.....	2
How To Order Replacement Parts.....	3
Illustration #1: Main Assembly.....	4
Parts listing: Illustration #1: Main Assembly.....	5
Illustration #2: Valve & Lubricator Assembly and Parts Listing.....	6
Illustration #3: Piston & Cylinder Assembly and Parts Listing.....	7
Limited Equipment Warranty of Sale.....	Back Page

Go to Discount-Equipment.com to order your parts



**ILLUSTRATION #1: MAIN ASSEMBLY**

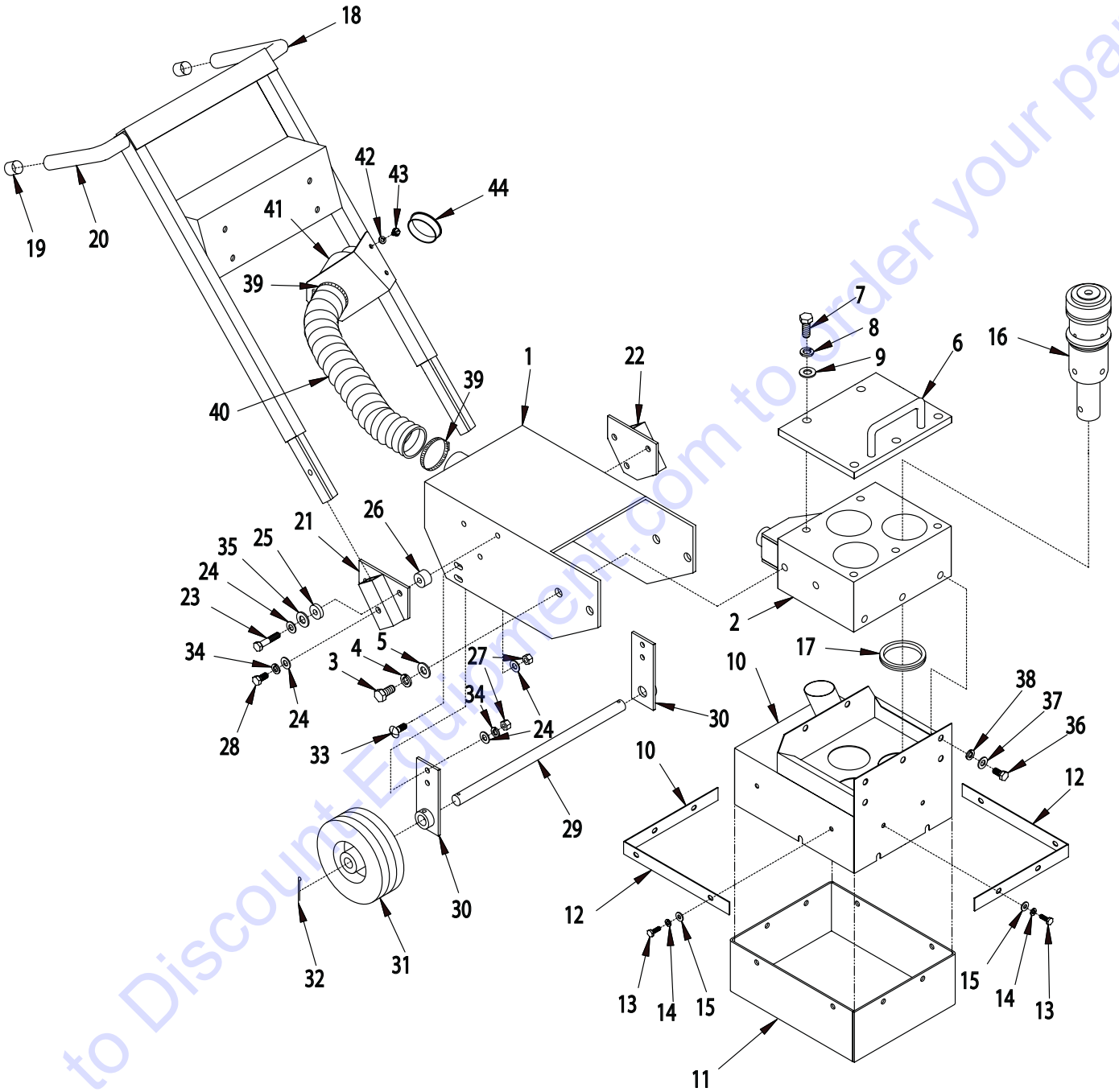

**PARTS LISTING - ILLUSTRATION # 1: MAIN ASSEMBLY**

ITEM#	PART#	DESCRIPTION	QTY.
1	63201	MAIN FRAME	1
2	63203	BLOCK, CYLINDER	1
3	10914	SCREW, CAP 1/2-13 x 1	4
4	10045	WASHER, LOCK 1/2	4
5	10312	WASHER, FLAT 1/2	4
6	63202	PLATE, CYLINDER BLOCK TOP	1
7	10356	SCREW, CAP 1/2-13 x 1-1/2	5
8	10045	WASHER, LOCK 1/2	5
9	10312	WASHER, FLAT 1/2	5
10	63204	EXHAUST BOX	1
11	63206	SKIRT, RUBBER 4 x 41-1/2	1
12	63205	STRAP, RUBBER SKIRT	2
13	10018	SCREW, CAP 1/4-20 x 3/4	8
14	10038	WASHER, LOCK 1/4	8
15	10602	WASHER, FLAT 1/4	8
16	63010	PISTON & CYLINDER ASSEMBLY (SEE ILLUS. # 3)	3
17	63110	GROMMET 2-1/2"ID x 1/16"GRV. x 2-3/4"GD	3
18	63208	HANDLE BAR	1
19	28034	CAP, RD. BLK. RUBBER 13/16"ID x 1"L	2
20	63211	GRIP, BLACK NEOPRENE 9-3/8"	2
21	63210	MOUNT, HANDLE BAR, RIGHT SIDE	1
22	63209	MOUNT, HANDLE BAR, LEFT SIDE	1
23	10029	SCREW, CAP 3/8-24 x 1-3/4	6
24	10025	WASHER, FLAT 3/8	18
25	56018	BUSHING, RUBBER 1"OD x 3/8"ID x 1/4	6
26	10034	BUSHING, RUBBER 1"OD x 3/8"ID x 5/8	6
27	10004	LOCK NUT 3/8-24	10
28	10055	SCREW, CAP 3/8-16 x 1"	2
29	63207	AXLE SHAFT 3/4 x 15-9/32	1
30	63217	BRACKET, AXLE SHAFT	2
31	80028	WHEEL 6 x 2 x 3/4" BRG.	2
32	10306	PIN, COTTER 3/16 x 1-1/4	2
33	10802	BOLT, CARRIAGE 3/8-16 x 1	4
34	10811	WASHER, LOCK 3/8	6
35	10312	WASHER, FLAT 1/2"	6
36	10907	SCREW, CAP 3/8-16 x 3/4	5
37	10025	WASHER, FLAT 3/8	5
38	10811	WASHER, LOCK 3/8	5
39	10766	CLAMP, HOSE, SAE #28, ADJ. TO 2-1/4	2
40	63222	HOSE, FLEX 2"ID X 15"L	1
41	86347	BRACKET, MULTI-VAC PORT 2-3"	1
42	10038	WASHER, LOCK 1/4	2
43	10846	SCREW, CAP STSHW 1/4-20 X 1/2	2
44	65021	PLUG, CAP 2"	1



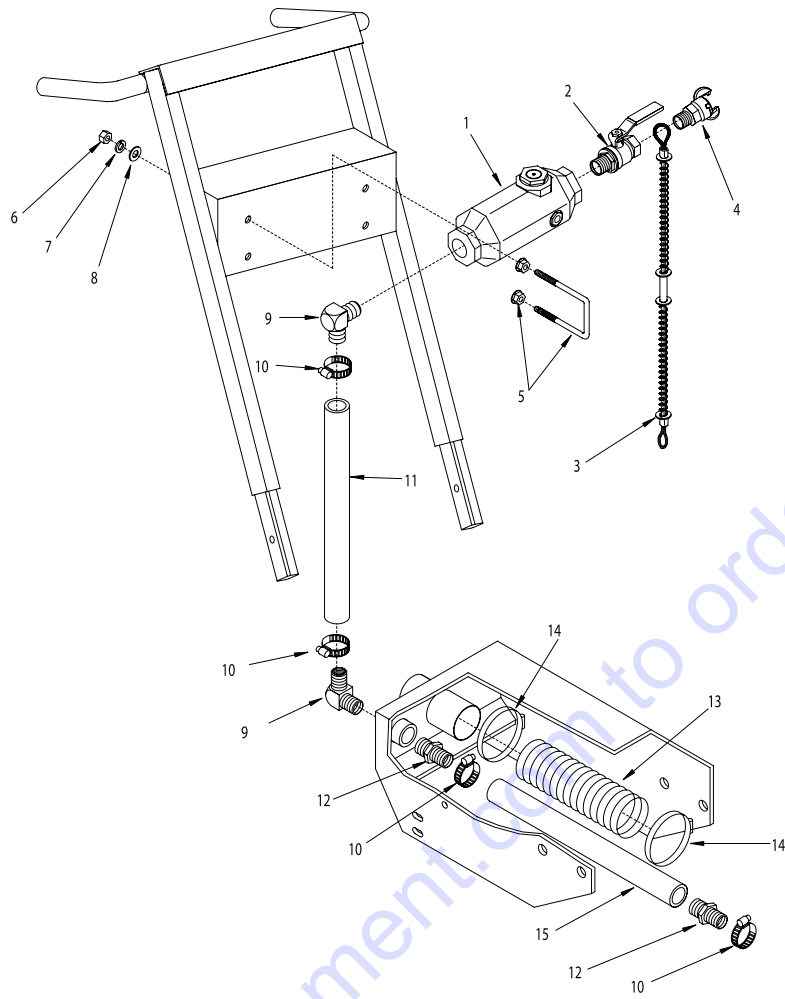
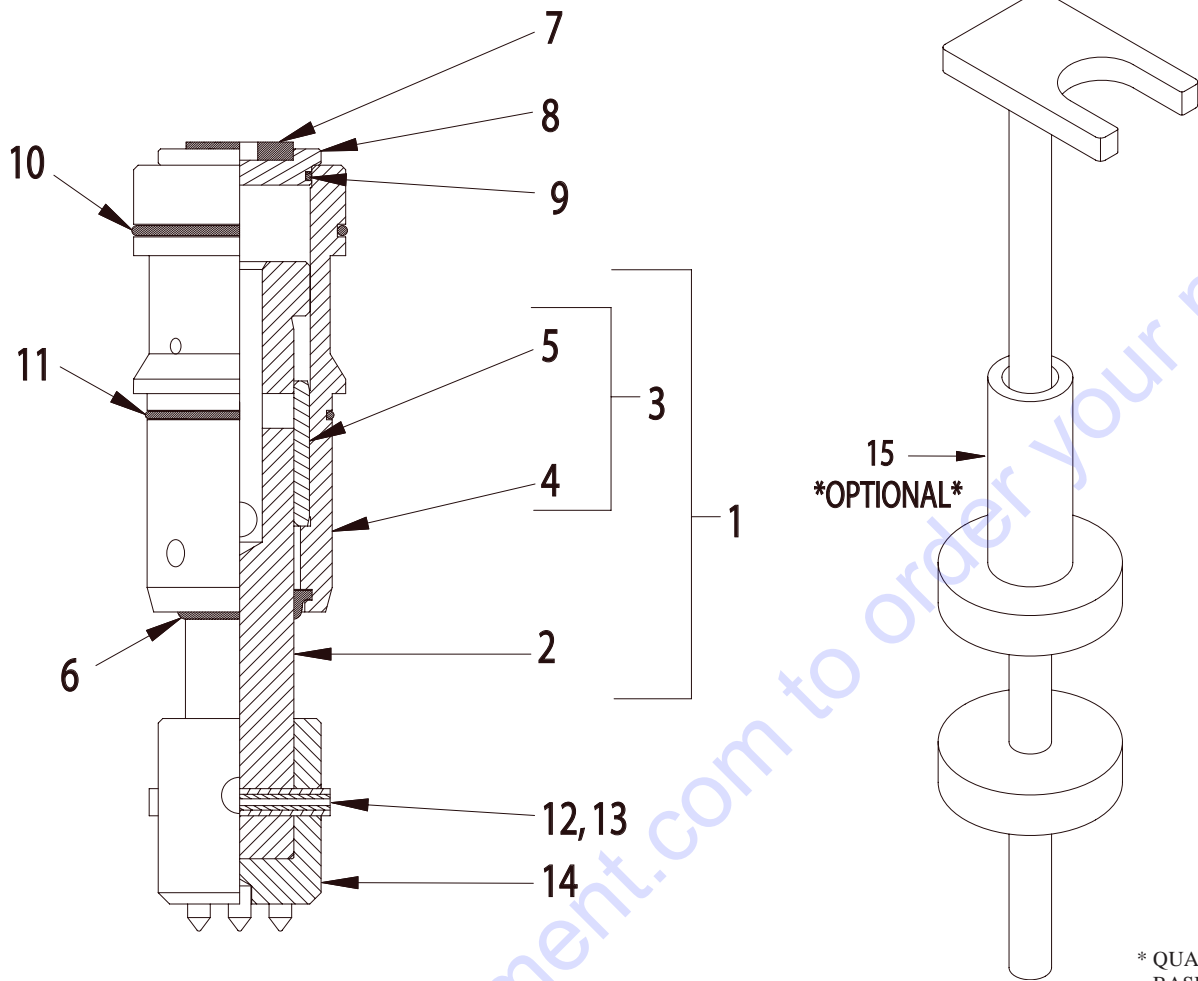

ILLUSTRATION 2: VALVE & LUBRICATOR ASSEMBLY

ITEM#	PART#	DESCRIPTION	QTY.
1	63212	LUBRICATOR, 1/2 PINT, 3/4" NPT	1
2	63213	VALVE, BALL 3/4FPT x 3/4MPT	1
3	63040	CABLE, WHIP-CHEK SAFETY 1/8 x 20-1/4	1
4	63067	COUPLER, AIR HOSE 3/4 MPT	1
5	63214C	U-BOLT, SQ. BEND, 2 x 3.5 (INCLUDES 2 NUTS)	2
6	10404	NUT 3/8-16	4
7	10811	WAHER, LOCK 3/8	4
8	10025	WASHER, FLAT 3/8	4
9	63215	BARB ELBOW 90°, 3/4 HOSE x 3/4 MPT	2
10	11645	CLAMP, HOSE, SAE #12, ADJ. TO 1-1/4	4
11	63218	HOSE, AIR 3/4" ID x 18-3/8	1
12	63216	BARB, 3/4 HOSE x 3/4 MPT (BRASS)	2
13	63221	HOSE, FLEXIBLE 2" ID x 11-1/2"L	1
14	10745	CLAMP, HOSE, SAE #32, ADJ. TO 2-1/2	2
15	63219	HOSE, AIR 3/4" ID x 6-1/2	1



\* QUANTITY  
BASED ON  
ONE HEAD

ILLUSTRATION 3: PISTON & CYLINDER ASSEMBLY

ITEM #	PART #	DESCRIPTION	QTY.
-	63010	PISTON & CYLINDER ASSEMBLY (INCLUDES ITEMS 1-11)	3
1	63010S	PISTON & CYLINDER SET (INCLUDES ITEMS 2 & 3)	1
2	63018	PISTON	1
3	63070	CYLINDER & LINER ASSEMBLY (INCLUDES ITEMS 4 & 5)	1
4	-----	CYLINDER (DO NOT REPLACE SEPARATELY)	
5	63014	LINER, CYLINDER (NOTE: PRESSED FIT IN CYLINDER)	
6	63019	WIPER RING, PISTON	1
7	63011	INSERT, TOP CAP	1
8	63012	CAP, CYLINDER TOP	1
9	63013	O-RING #133, 3/32 X 1-13/16"ID	1
10	63016	O-RING #231, 1/8 X 2-5/8"ID	1
11	63017	O-RING #141, 3/32 X 2-5/16"ID	1
12	10007	PIN, ROLL 3/8 X 2-1/2 (INCLUDED WITH BIT, ITEM 14)	1
13	63055	PIN, ROLL 7/32 X 2-1/2 (INCLUDED WITH BIT, ITEM 14)	1
14		BIT W/ PINS, TUNGSTEN CARBIDE (NOT INCLUDED w/ ASSEMBLY)	1
	18810	5-POINT (ROUGH TEXTURE)	
	18820	9-POINT (MEDIUM TEXTURE)	
15	63220	OPTIONAL BIT REMOVING TOOL (SLIDE HAMMER)	1





# PARTS FINDER

**Search Website  
by Part Number**



**Search Manual  
Library For Parts  
Manual & Lookup Part  
Numbers – Purchase  
or Request Quote**

**Search Manuals**

Enter your information to help us find the right parts manual for your machine.

\* Brand:

\* Model:

\* Serial:

\* Part Number:

SEARCH

**Can't Find Part or  
Manual? Request Help  
by Manufacturer,  
Model & Description**

**Parts Order Form**

Please fill in the following information to help us find the right part for your machine.

Manufacturer:	<input type="text"/>
Model:	<input type="text"/>
Description:	<input type="text"/>
Part Number:	<input type="text"/>
Quantity:	<input type="text"/>
Notes:	<input type="text"/>

Discount-Equipment.com is your online resource for quality parts & equipment.

Florida: **561-964-4949** Outside Florida TOLL FREE: **877-690-3101**

**Need parts?**

Click on this link: <http://www.discount-equipment.com/category/5443-parts/> and choose one of the options to help get the right parts and equipment you are looking for. Please have the machine model and serial number available in order to help us get you the correct parts. If you don't find the part on the website or on one of the online manuals, please fill out the request form and one of our experienced staff members will get back to you with a quote for the right part that your machine needs.

We sell worldwide for the brands: Genie, Terex, JLG, MultiQuip, Mikasa, Essick, Whiteman, Mayco, Toro Stone, Diamond Products, Generac Magnum, Airman, Haulotte, Barreto, Power Blanket, Nifty Lift, Atlas Copco, Chicago Pneumatic, Allmand, Miller Curber, Skyjack, Lull, Skytrak, Tsurumi, Husquvarna Target, Stow, Wacker, Sakai, Mi-T-M, Sullair, Basic, Dynapac, MBW, Weber, Bartell, Bennar Newman, Haulotte, Ditch Runner, Menegotti, Morrison, Contec, Buddy, Crown, Edco, Wyco, Bomag, Laymor, EZ Trench, Bil-Jax, F.S. Curtis, Gehl Pavers, Heli, Honda, ICS/PowerGrit, IHI, Partner, Imer, Clipper, MMD, Koshin, Rice, CH&E, General Equipment, Amida, Coleman, NAC, Gradall, Square Shooter, Kent, Stanley, Tamco, Toku, Hatz, Kohler, Robin, Wisconsin, Northrock, Oztec, Toker TK, Rol-Air, APT, Wylie, Ingersoll Rand / Doosan, Innovatech, Con X, Ammann, Mecalac, Makinex, Smith Surface Prep, Small Line, Wanco, Yanmar