

OPERATION MANUAL



www.Discount-Equipment.com

Mikasa **SERIES**
MODEL MVC-90H
ONE-WAY PLATE COMPACTOR
(HONDA GX160K1QMX2/GX160U1QMX2
GASOLINE ENGINES)

Revision #4 (06/12/20)



THIS MANUAL MUST ACCOMPANY THE EQUIPMENT AT ALL TIMES.

TO PURCHASE THIS PRODUCT PLEASE CONTACT US



**Equipment Financing and
Extended Warranties Available**



**Discount-Equipment.com is your online resource for
commercial and industrial quality parts and equipment sales.**

561-964-4949

visit us on line @ www.discount-equipment.com

Select an option below to find your Equipment

Search by Manufacturer

Search by Product Type

Request a Quote

We sell worldwide for the brands: Genie, Terex, JLG, MultiQuip, Mikasa, Essick, Whiteman, Mayco, Toro Stone, Diamond Products, Generac Magnum, Airman, Haulotte, Barreto, Power Blanket, Nifty Lift, Atlas Copco, Chicago Pneumatic, Allmand, Miller Curber, Skyjack, Lull, Skytrak, Tsurumi, Husquvarna Target, Stow, Wacker, Sakai, Mi-T-M, Sullair, Basic, Dynapac, MBW, Weber, Bartell, Bennar Newman, Haulotte, Ditch Runner, Menegotti, Morrison, Contec, Buddy, Crown, Edco, Wyco, Bomag, Laymor, EZ Trench, Bil-Jax, F.S. Curtis, Gehl Pavers, Heli, Honda, ICS/PowerGrit, IHI, Partner, Imer, Clipper, MMD, Koshin, Rice, CH&E, General Equipment, Amida, Coleman, NAC, Gradall, Square Shooter, Kent, Stanley, Tamco, Toku, Hatz, Kohler, Robin, Wisconsin, Northrock, Oztec, Toker TK, Rol-Air, APT, Wylie, Ingersoll Rand / Doosan, Innovatech, Con X, Ammann, Mecalac, Makinex, Smith Surface Prep, Small Line, Wanco, Yanmar



To order go to Discount-Equipment.com

**MULTIQUIP MVC-90H
PLATE COMPACTOR**

Proposition 65 Warning2
 Table Of Contents3
 Safety Information 4-8
 Dimensions 10
 Specifications 11
 General Information 12
 Components (Plate Compactor) 13
 Components (Honda Engine) 14
 Inspection 15-16
 Start-Up Procedure 17
 Shutdown Procedure 18
 Operation 19
 Maintenance 20-22
 Preparation For Long Term Storage 23
 Troubleshooting (Engine) 24-25
 Troubleshooting (Compactor) 26

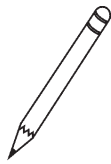
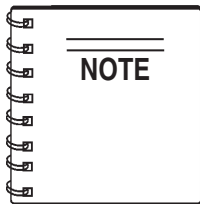

Specification and part number are subject to change without notice.

To order go to Discount-Equipment.com

SAFETY INFORMATION

Do not operate or service the equipment before reading the entire manual. Safety precautions should be followed at all times when operating this equipment. Failure to read and understand the safety messages and operating instructions could result in injury to yourself and others.



SAFETY MESSAGES

The four safety messages shown below will inform you about potential hazards that could injure you or others. The safety messages specifically address the level of exposure to the operator and are preceded by one of four words: **DANGER**, **WARNING**, **CAUTION** or **NOTICE**.

SAFETY SYMBOLS

! DANGER

Indicates a hazardous situation which, if not avoided, **WILL** result in **DEATH** or **SERIOUS INJURY**.

! WARNING

Indicates a hazardous situation which, if not avoided, **COULD** result in **DEATH** or **SERIOUS INJURY**.







! CAUTION

Indicates a hazardous situation which, if not avoided, **COULD** result in **MINOR** or **MODERATE INJURY**.

NOTICE

Addresses practices not related to personal injury.

Potential hazards associated with the operation of this equipment will be referenced with hazard symbols which may appear throughout this manual in conjunction with safety messages.

Symbol	Safety Hazard
	Lethal exhaust gas hazards
	Explosive fuel hazards
	Burn hazards
	Respiratory hazards
	Accidental starting hazards
	Eye and hearing hazards
	Rotating parts hazards

SAFETY INFORMATION

GENERAL SAFETY

CAUTION

- **NEVER** operate this equipment without proper protective clothing, shatterproof glasses, respiratory protection, hearing protection, steel-toed boots and other protective devices required by the job or city and state regulations.



- **NEVER** operate this equipment when not feeling well due to fatigue, illness or when under medication.



- **NEVER** operate this equipment under the influence of drugs or alcohol.



- **ALWAYS** check the equipment for loosened threads or bolts before starting.
- **DO NOT** use the equipment for any purpose other than its intended purposes or applications.
- **ALWAYS** clear the work area of any debris, tools, etc. that would constitute a hazard while the equipment is in operation.

NOTICE

- This equipment should only be operated by trained and qualified personnel 18 years of age and older.
- Whenever necessary, replace nameplate, operation and safety decals when they become difficult read.
- Manufacturer does not assume responsibility for any accident due to equipment modifications. Unauthorized equipment modification will void all warranties.
- **NEVER** use accessories or attachments that are not recommended by Multiquip for this equipment. Damage to the equipment and/or injury to user may result.
- **ALWAYS** know the location of the nearest **fire extinguisher**.
- **ALWAYS** know the location of the nearest **first aid kit**.
- **ALWAYS** know the location of the nearest phone or **keep a phone on the job site**. Also, know the phone numbers of the nearest **ambulance, doctor and fire department**. This information will be invaluable in the case of an emergency.

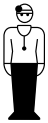

To order go to www.discount-equipment.com

SAFETY INFORMATION

COMPACTOR SAFETY

DANGER

- **NEVER** operate the equipment in an explosive atmosphere or near combustible materials. An explosion or fire could result causing severe **bodily harm or even death.**



WARNING

- **NEVER** disconnect any **emergency or safety devices.** These devices are intended for operator safety. Disconnection of these devices can cause severe injury, bodily harm or even death. Disconnection of any of these devices will void all warranties.

CAUTION

- **NEVER** lubricate components or attempt service on a running machine.

NOTICE

- **ALWAYS** keep the machine in proper running condition.
- Fix damage to machine and replace any broken parts immediately.
- **ALWAYS** store equipment properly when it is not being used. Equipment should be stored in a clean, dry location out of the reach of children and unauthorized personnel.

ENGINE SAFETY

DANGER

- The engine fuel exhaust gases contain poisonous carbon monoxide. This gas is colorless and odorless, and can cause death if inhaled.
- The engine of this equipment requires an adequate free flow of cooling air. **NEVER** operate this equipment in any enclosed or narrow area where free flow of the air is restricted. If the air flow is restricted it will cause injury to people and property and serious damage to the equipment or engine.



WARNING

- **DO NOT** place hands or fingers inside engine compartment when engine is running.
- **NEVER** operate the engine with heat shields or guards removed.
- Keep fingers, hands hair and clothing away from all moving parts to prevent injury.
- **DO NOT** remove the radiator cap while the engine is hot. High pressure boiling water will gush out of the radiator and severely scald any persons in the general area of the compactor.
- **DO NOT** remove the coolant drain plug while the engine is hot. Hot coolant will gush out of the coolant tank and severely scald any persons in the general area of the compactor.
- **DO NOT** remove the engine oil drain plug while the engine is hot. Hot oil will gush out of the oil tank and severely scald any persons in the general area of the compactor.



CAUTION

- **NEVER** touch the hot exhaust manifold, muffler or cylinder. Allow these parts to cool before servicing equipment.



NOTICE

- **NEVER** run engine without an air filter or with a dirty air filter. Severe engine damage may occur. Service air filter frequently to prevent engine malfunction.
- **NEVER** tamper with the factory settings of the engine or engine governor. Damage to the engine or equipment can result if operating in speed ranges above the maximum allowable.
- **NEVER** tip the engine to extreme angles during lifting as it may cause oil to gravitate into the cylinder head, making the engine start difficult.





SAFETY INFORMATION

FUEL SAFETY

DANGER

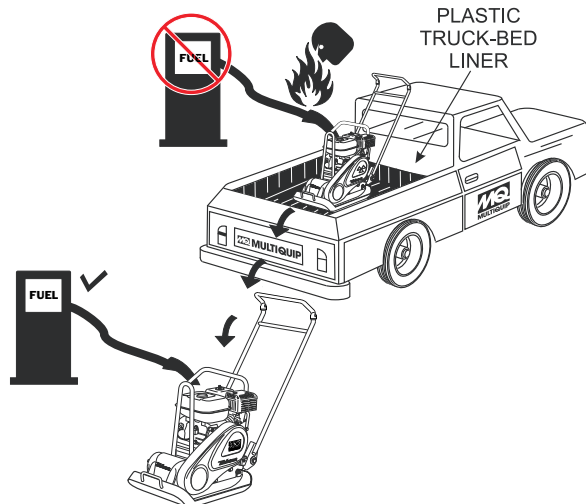
- **DO NOT** add fuel to equipment if it is placed inside truck bed with plastic liner. Possibility exists of explosion or fire due to static electricity.



- **DO NOT** start the engine near spilled fuel or combustible fluids. Diesel fuel is extremely flammable and its vapors can cause an explosion if ignited.
- **ALWAYS** refuel in a well-ventilated area, away from sparks and open flames.
- **ALWAYS** use extreme caution when working with **flammable** liquids.
- **DO NOT** fill the fuel tank while the engine is running or hot.
- **DO NOT** overfill tank, since spilled fuel could ignite if it comes into contact with hot engine parts or sparks from the ignition system.
- Store fuel in appropriate containers, in well-ventilated areas and away from sparks and flames.
- **NEVER** use fuel as a cleaning agent.
- **DO NOT** smoke around or near the equipment. Fire or explosion could result from fuel vapors or if fuel is spilled on a hot engine. 

BATTERY SAFETY (ELECTRIC START ONLY)

DANGER

- **DO NOT** drop the battery. There is a possibility that the battery will explode.
- **DO NOT** expose the battery to open flames, sparks, cigarettes, etc. The battery contains combustible gases and liquids. If these gases and liquids come into contact with a flame or spark, an explosion could occur. 

WARNING

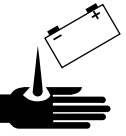
- **ALWAYS** wear safety glasses when handling the battery to avoid eye irritation. The battery contains acids that can cause injury to the eyes and skin. 
- Use well-insulated gloves when picking up the battery.
- **ALWAYS** keep the battery charged. If the battery is not charged, combustible gas will build up.
- **DO NOT** charge battery if frozen. Battery can explode. When frozen, warm the battery to at least 61°F (16°C).
- **ALWAYS** recharge the battery in a well-ventilated environment to avoid the risk of a dangerous concentration of combustible gases.
- If the battery liquid (dilute sulfuric acid) comes into contact with **clothing or skin**, rinse skin or clothing immediately with plenty of water. 
- If the battery liquid (dilute sulfuric acid) comes into contact with **eyes**, rinse eyes immediately with plenty of water and contact the nearest doctor or hospital to seek medical attention.

CAUTION

- **ALWAYS** disconnect the **NEGATIVE** battery terminal before performing service on the equipment.
- **ALWAYS** keep battery cables in good working condition. Repair or replace all worn cables.

TRANSPORTING SAFETY

CAUTION

- NEVER allow any person or animal to stand underneath the equipment while lifting.

NOTICE

- Before lifting, make sure that the equipment parts (hook and vibration insulator) are not damaged and screws are not loose or missing.
- Always make sure crane or lifting device has been properly secured to the lifting bail (hook) of the equipment.
- **ALWAYS** shutdown engine before transporting.
- **NEVER** lift the equipment while the engine is running.
- Tighten fuel tank cap securely and close fuel cock to prevent fuel from spilling.
- Use adequate lifting cable (wire or rope) of sufficient strength.
- Use one point suspension hook and lift straight upwards.
- **DO NOT** lift machine to unnecessary heights.
- **ALWAYS** tie down equipment during transport by securing the equipment with rope.

ENVIRONMENTAL SAFETY

NOTICE

- Dispose of hazardous waste properly. Examples of potentially hazardous waste are used motor oil, fuel and fuel filters. 
- **DO NOT** use food or plastic containers to dispose of hazardous waste.
- **DO NOT** pour waste, oil or fuel directly onto the ground, down a drain or into any water source.

MVC-90H PLATE COMPACTOR — DIMENSIONS

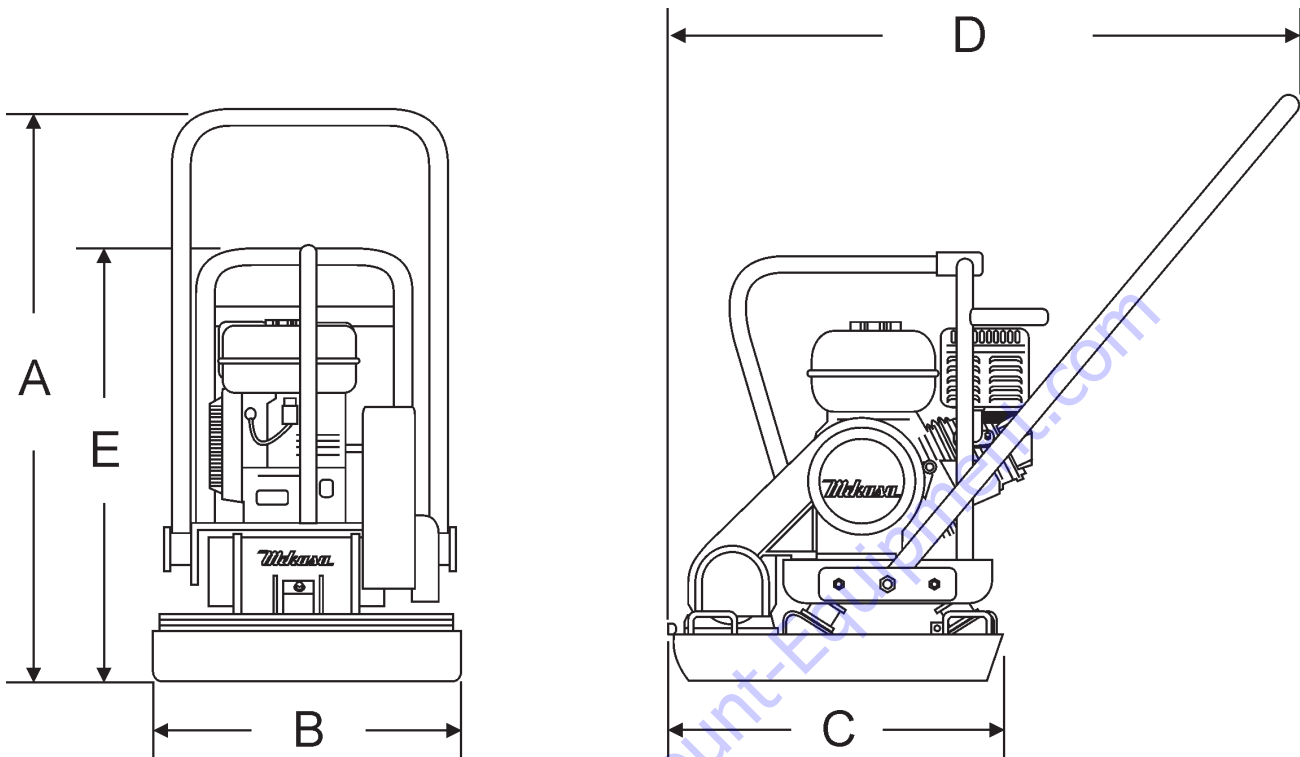

Figure 1. MVC-90H Plate Compactor Dimensions

TABLE 3. DIMENSIONS

Reference Letter	Description	Dimensions in. (mm)
A	Height (Handle Deployed)	34 in. (863.6 mm.)
B	Overall Width	21 in. (533 mm.)
C	Length (Plate only)	23 in. (584 mm.)
D	Length (Handle Deployed)	48 in. (1,219 mm.)
E	Height (Handle Detached)	31 in. (787 mm.)

MVC-90H PLATE COMPACTOR — SPECIFICATIONS

TABLE 1. COMPACTOR SPECIFICATIONS

Model	MVC-90H
Centrifugal Force	3,350 lbs. (1,520 kg)
Vibration Frequency	5,600 vpm (93 Hz)
Maximum Forward Speed	82 ft/min (25 m/min)
Plate Size (L x W)	22 x 19.6 in (560 x 500 mm)
Operating Weight	194 lbs. (88 kg)
Maximum Area of Compaction	8,036 sq. ft/hr (746 sq. m/hr)
HP Rating	5.5 BHP (4.2 KW)
Water Tank Capacity	5.6 qts. (5.3 liters)

TABLE 2. ENGINE SPECIFICATIONS

Engine Make	HONDA
Engine Model	GX160K1QMX2/GX160U1QMX2
Engine Type	Air-cooled, 4-stroke, Single Cylinder, OHV, Horizontal Shaft Gasoline Engine
Displacement	9.9 cu. in (163 cc)
Maximum Output	5 H.P./3,600 rpm
Oil Capacity	1.3 pints (0.6 liters)
Fuel Type	Unleaded
Fuel Tank Capacity	0.95 gallons (3.6 liters)
Dry Weight	33.1 lbs./ (15 kg)
Speed Control Method	Centrifugal Flyweight Type
Starting Method	Recoil Start
Dimensions (L x W x H)	12.0 x 14.4 x 13.2 in (304 x 362 x 335 mm)

MVC-90H PLATE COMPACTOR — GENERAL INFORMATION

Definition of Plate Compactor

The Mikasa MVC-90H is a walk behind, plate compactor designed for the compaction of sand, mixed soils and asphalt. This plate compactor is a powerful compacting tool capable of applying a tremendous force in consecutive high frequency vibrations to a soil surface. Its applications include compacting for road, embankments and reservoirs as well as backfilling for gas pipelines, water pipelines and cable installation work.

The MVC-90H has a heavy-duty steel base plate with closed design. It is ribbed for extra strength. The tubular steel roll bar cage protects engine components and provides a lifting point.

The MVC-90H also has a reversible, shock-mounted handle.

Vibratory Plate

The vibratory plate of the compactor produce low amplitude high frequency vibrations, designed to compact granular soils and asphalt.

The resulting vibrations cause forward motion. The engine and handle are vibration isolated from the vibrating plate.

The double-V belt drive assures less downtime and superior drive characteristics. Unit can still operate if one belt breaks.

Water Tank

The compactor has a built-in water tank which helps prevent damage and adds to long life. Brass water valve eliminates rust and corrosion problems.

Frequency/Speed

The compactor's vibrating plate has a frequency range between 5,800 vpm (vibrations per minute). The forward and reverse travel speed of the compactor is approximately 82 ft./minute (25 meters/minute).

Engine

The Mikasa MVC-90H Plate Compactor is equipped with a Honda GX160K1QMX2/GX160U1QMX2 air cooled, 4-cycle gasoline engine. The engine drives an eccentric weight at a high speed to develop a compaction force.

Controls

Before starting the MVC-90H Plate Compactor identify and understand the function of the controls and components.

MVC-90H PLATE COMPACTOR — COMPONENTS (PLATE COMPACTOR)

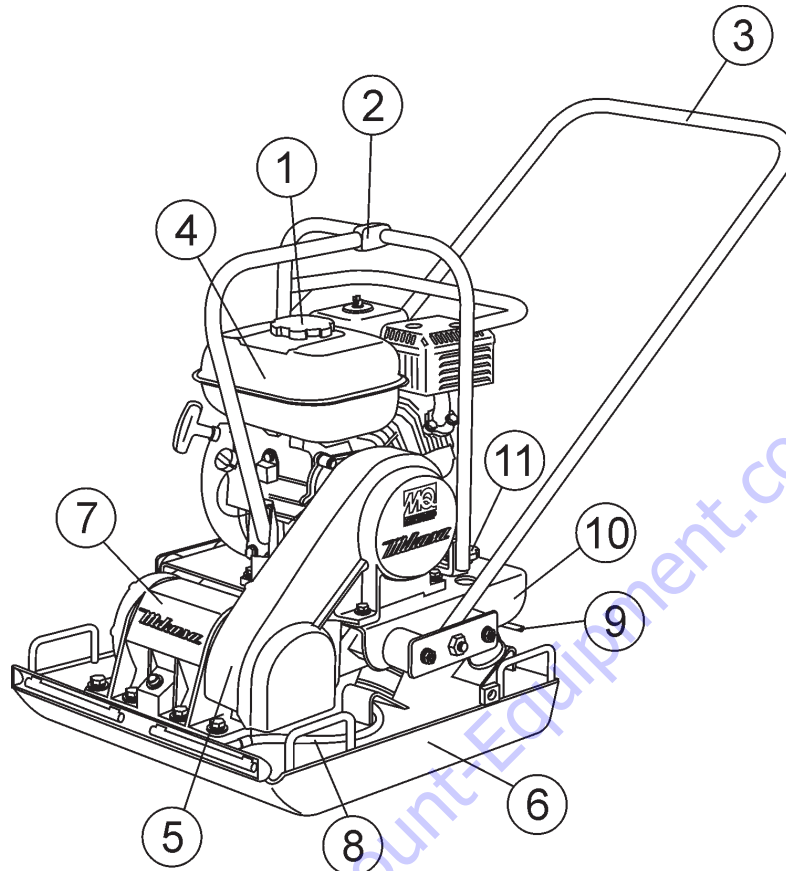

Figure 3. MVC-90H Plate Compactor Components

Figure 3 shows the location of the components and general maintenance parts. The function of each component is described below:

1. **Fuel Tank Cap** – Remove this cap to add fuel.
2. **Lifting Bale** – When lifting of the compactor is required either by forklift, crane etc., tie a rope or chain around this lifting point.
3. **Handle Bar** – When operating the compactor use this handle bar to maneuver the compactor.
4. **Gasoline Engine** – This plate compactor uses a Honda GX160K1QMX2/GX160U1QMX2 engine. Refer to the Honda owner's manual for engine information and related topics.
5. **Belt Cover** – Remove this cover to gain access to the V-belts. **NEVER** run the compactor without the V-belt cover. If the V-belt cover is not installed, the possibility exist that your hand may get caught between the V-belt and clutch, thus causing serious injury and bodily harm.
6. **Vibrating Plate** – A flat, open plate made of durable cast iron construction used in the compacting of soil.
7. **Vibration Case** – Encloses the eccentric, gears and counter weights.
8. **Water Tube (Sprinkler)** – Supplies water to the soil via a splash plate.
9. **Water Shut-Off Valve** – Turn this valve downward to let water flow from the water tank to the water tube.
10. **Water Tank** – Holds 5.6 quarts of water, built-in.
11. **Water Tank Cap** – Remove this cap to add water to the water tank.

MVC-90H PLATE COMPACTOR — COMPONENTS (HONDA ENGINE)

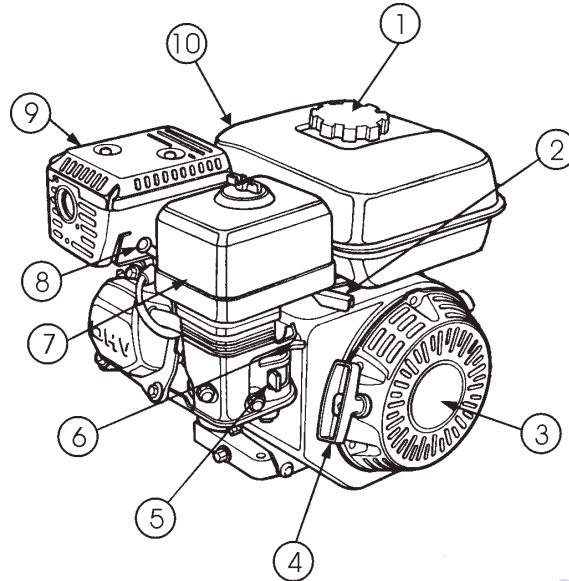

Figure 4. Honda GX160K1QMX2 Engine Controls & Components

The engine (Figure 4) must be checked for proper lubrication and filled with fuel prior to operation. Refer to the manufacturer's Engine manual for instructions & details of operation and servicing.

1. **Fuel Filler Cap** – Remove this cap to add unleaded gasoline to the fuel tank. Make sure cap is tightened securely. **DO NOT** over fill.

! CAUTION - Fueling The Engine

Adding fuel to the tank should be done only when the engine is stopped and has had an opportunity to cool down. In the event of a fuel spill, **DO NOT** attempt to start the engine until the fuel residue has been completely wiped up, and the area surrounding the engine is dry.



2. **Throttle Lever** – Used to adjust engine RPM speed (lever advanced forward **SLOW**, lever back toward operator **FAST**).
3. **Engine ON/OFF Switch** – **ON** position permits engine starting, **OFF** position stops engine operations.
4. **Recoil Starter (pull rope)** – Manual-starting method. Pull the starter grip until resistance is felt, then pull briskly and smoothly.
5. **Fuel Valve Lever** – **OPEN** to let fuel flow, **CLOSE** to stop the flow of fuel.

6. **Choke Lever** – Used in the starting of a cold engine, or in cold weather conditions. The choke enriches the fuel mixture.
7. **Air Cleaner** – Prevents dirt and other debris from entering the fuel system. Remove wing-nut on top of air filter canister to gain access to filter element.

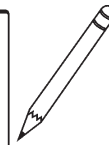
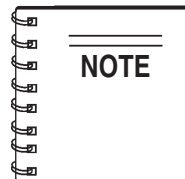

Operating the engine without an air filter, with a damaged air filter, or a filter in need of replacement will allow dirt to enter the engine, causing rapid engine wear.

8. **Spark Plug** – Provides spark to the ignition system. Set spark plug gap to 0.6 - 0.7 mm (0.028 - 0.031 inch) for HONDA engine, and 0.5 - 0.6 mm (0.020 - 0.024 inch) for ROBIN engine. Clean spark plug once a week.
9. **Muffler** – Used to reduce noise and emissions.

! CAUTION - Burn Hazard

Engine components can generate extreme heat. To prevent burns, **DO NOT** touch these areas while the engine is running or immediately after operating. **NEVER** operate the engine with the muffler removed.



10. **Fuel Tank** – Holds unleaded gasoline. For additional information refer to engine owner's manual.

MVC-90H PLATE COMPACTOR — INSPECTION

Before Starting:

CAUTION - General Safety Precautions

NEVER operate the compactor in a confined area or enclosed area structure that does not provide ample **free flow of air**.

ALWAYS wear approved eye and hearing protection before operating the compactor.

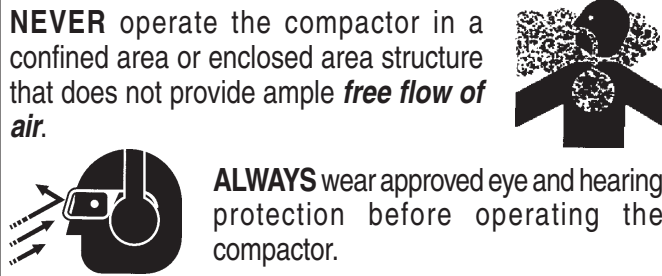

- Read safety instructions at the beginning of manual.
 - Remove dirt and dust, particularly in the engine cooling air inlet, carburetor and air cleaner.
 - Check the air filter for dirt and dust. If air filter is dirty, clean or replace the air filter with a new one as required.
 - Check carburetor for external dirt and dust. Clean with dry compressed air.
 - Check fastening nuts and bolts for tightness.
 - Check the Engine Oil level.
 - Check the Fuel level.
 - Check the V-belt tension and wear.
 - Check the Vibrator Oil level.
- 

Engine Oil Check

1. To check the engine oil level, place the plate compactor on secure level ground with the engine stopped.
2. Remove the filler cap/dipstick from the engine oil filler hole (Figure 5) and wipe it clean.

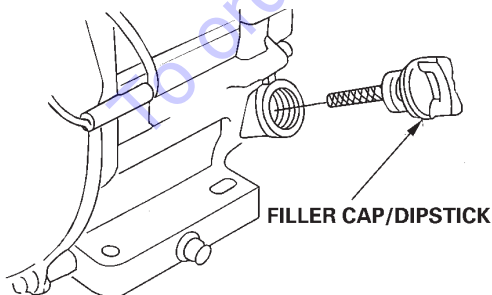

Figure 5. Engine Oil Dipstick

3. Insert and remove the dipstick without screwing it into the filler neck. Check the oil level shown on the dipstick.
4. If the oil level is low (Figure 6), fill to the edge of the oil filler hole with the recommended oil type (Table 4). Maximum oil capacity is 400 cc.

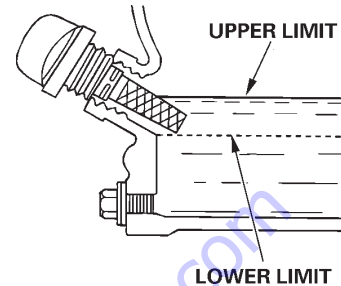
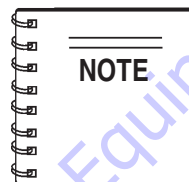

Figure 6. Engine Oil Dipstick



The Oil Alert system will automatically stop the engine before the engine falls below safe limits. Always be sure to check the engine oil level prior to starting the engine.

Table 4. Oil Type

Season	Temperature	Oil Type
Summer	25°C or Higher	SAE 10W-30
Spring/Fall	25°C~10°C	SAE 10W-30/20
Winter	0°C or Lower	SAE 10W-10

MVC-90H PLATE COMPACTOR — INSPECTION

Fuel Check:

1. Remove the gasoline cap located on top of fuel tank.
2. Visually inspect to see if the fuel level is low. If fuel is low, replenish with unleaded fuel.
3. When refueling, be sure to use a strainer for filtration. **DO NOT** top-off fuel. Wipe up any spilled fuel **immediately!**

WARNING - Explosive Fuel

Gasoline is extremely flammable, and its vapors can cause an explosion if ignited. **DO NOT** start the engine near spilled fuel or combustible fluids.



DO NOT fill the fuel tank while the engine is running or hot. **DO NOT** overfill tank, since spilled fuel could ignite if it comes into contact with hot engine parts or sparks from the ignition system. Store fuel in approved containers, in well-ventilated areas and away from sparks and flames.

Vibrator Oil Check

1. Place the plate compactor horizontally on a flat surface. Make sure the compactor is level when checking the oil in the vibrator assembly.
2. Check vibrator oil level by removing the plug (vibrator oil gauge) as shown in Figure 7. The oil level should be up to the oil plug. The vibrator holds 140 cc (approximately 4 oz).

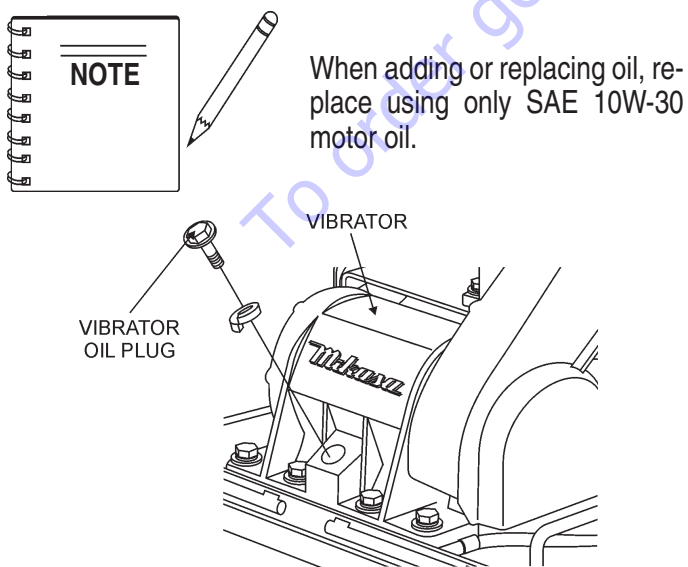

Figure 7. Vibrator Oil Plug

V-Belt Check

CAUTION - Checking and Replacing the V-Belt

NEVER attempt to check the V-belt with the engine running. Severe injury can occur if your hand gets caught between the V-belt and the clutch. Always use safety gloves.



1. To check the V-belt tension, remove the three bolts that secure the belt cover to the frame as shown in Figure 8.

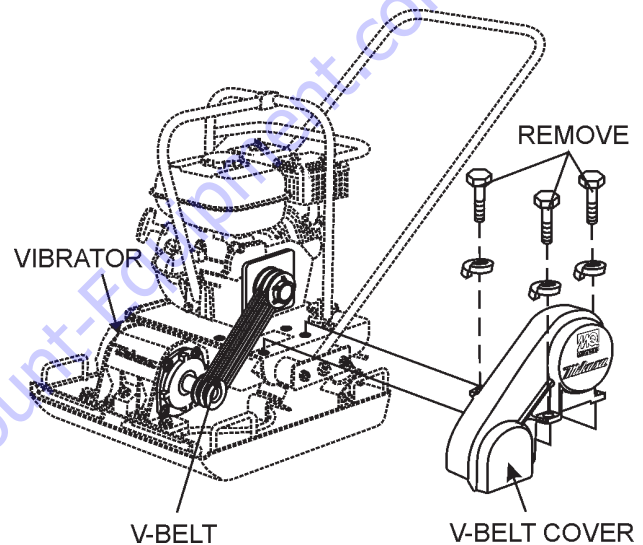

Figure 8. V-Belt Cover Removal

2. The V-belt tension is proper if the V-belt bends 10 to 15 mm (Figure 9) when depressed with finger at midway between the clutch and vibration pulley shafts.

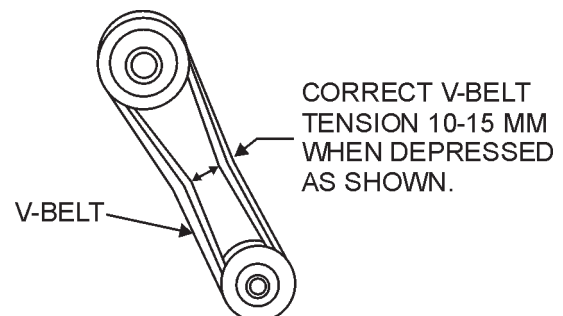

Figure 9. V-Belt Tension

3. A loose V-belt will decrease the power transmission output, causing reduced compaction and premature wear of the belt.
4. If the V-belt becomes worn or loose, replace it.

MVC-90H PLATE COMPACTOR — START-UP PROCEDURE

Starting the Engine (Honda engine):

This section is intended to assist the operator with the **initial start-up** of the compactor. It is extremely important that this section be read carefully before attempting to use the compactor in the field.

1. Place the **fuel valve lever** (Figure 10) in the **ON** position.

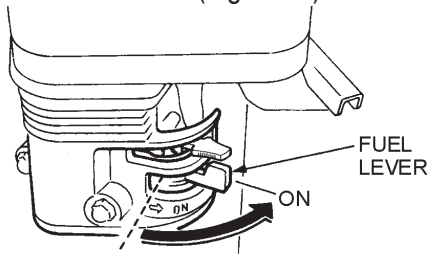

Figure 10. Fuel Valve Lever (ON Position)

2. Place the **Engine ON/OFF switch** (Figure 11) in the **ON** position.

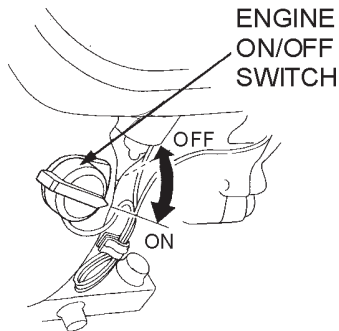

Figure 11. Engine ON/Off Switch (ON Position)

3. Place the **Choke Lever** (Figure 12) in the **OPEN** position.

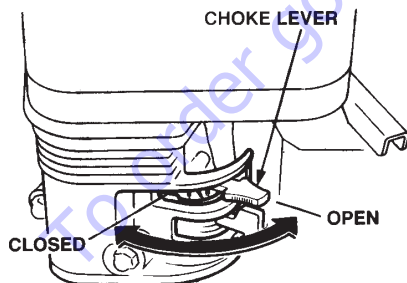
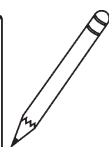
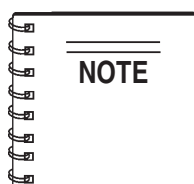

Figure 12. Choke Lever (OPEN Position)



The **CLOSED** position of the choke lever enriches the fuel mixture for starting a **COLD** engine. The **OPEN** position provides the correct fuel mixture for normal operation after starting, and for restarting a warm engine.

4. Place the **throttle lever** (Figure 13) halfway between **fast** and **slow**.

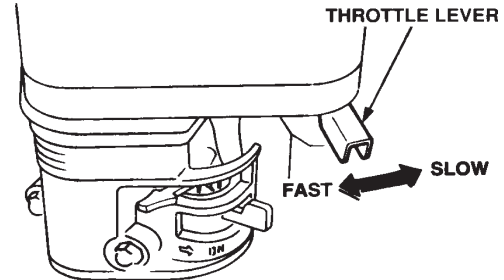

Figure 13. Throttle Lever (FAST Position)

5. Grasp the starter grip (Figure 14) and slowly pull it out. The resistance becomes the hardest at a certain position, corresponding the compression point. Rewind the rope a little from that point and pull out sharply.

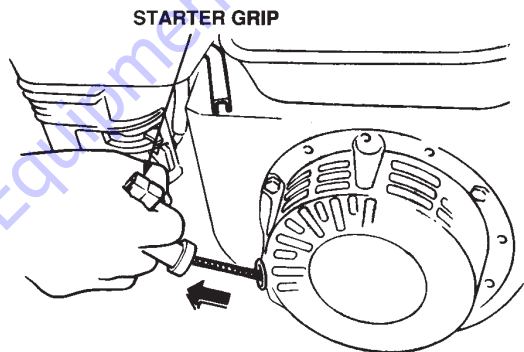

Figure 14. Recoil Starter Grip (Pull to Start)

CAUTION - Using the Recoil Starter Rope

DO NOT pull the starter rope all the way to the end.
DO NOT release the starter rope after pulling. Allow it to rewind as soon as possible.

6. If the engine has started, slowly return the choke lever (Figure 11) to the **CLOSED** position. If the engine has not started repeat steps 1 through 5.
7. Before the compactor is put into operation run the engine for 3-5 minutes.
8. Check for abnormal engine noises or fuel leaks.

MVC-90H PLATE COMPACTOR — SHUT-DOWN PROCEDURE

Stopping the Engine

CAUTION - Stopping the engine while working

NEVER stop the engine suddenly while working at high speeds. This can damage your engine.

Emergency Shutdown Procedure:

1. Move the throttle lever quickly to the **SLOW** position (Figure 15).
2. Place the engine **ON/OFF** switch in the **OFF** position (Figure 16).

1. Place the **throttle lever** (Figure 15) in **SLOW** position, and listen for the engine speed to decrease.

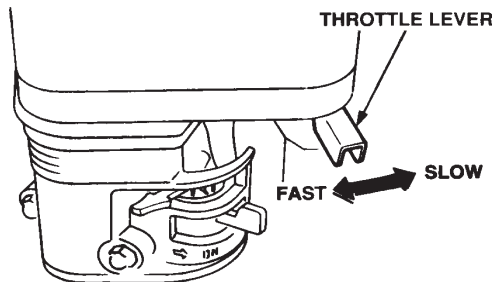

Figure 15. Throttle Lever (SLOW Position)

2. Place the **Engine ON/OFF switch** (Figure 16) in the **OFF** position.

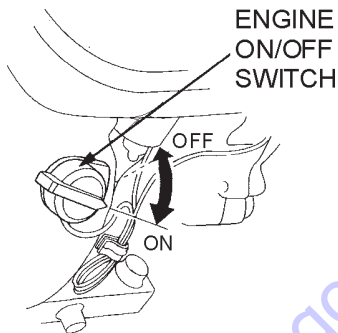

Figure 16. Engine ON/Off Switch (OFF Position)

3. Place the **fuel valve lever** (Figure 17) in the **OFF** position.

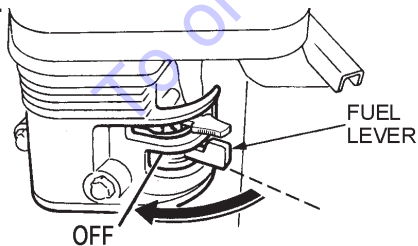

Figure 17. Fuel Valve Lever (OFF Position)

MVC-90H PLATE COMPACTOR — OPERATION

Operation

CAUTION - General Operation Safety

Make sure to follow all safety rules referenced in the safety section of this manual before operating compactor. Keep work area clear of debris and other objects that could cause damage to the compactor or bodily injury.

1. Once the engine has started, move the engine throttle lever quickly to the **FAST** position. With the throttle lever in the fast position, the engine speed should be around 2,300 RPM, which engages the centrifugal clutch.



Always move the throttle lever quickly without hesitation. Increasing the engine speed slowly causes the clutch to slip and can damage your clutch.

2. Firmly grasp the compactor's handle bar with both hands as the compactor begins moving forward.
3. Slowly walk behind the compactor and be on the lookout for any large objects or foreign matter that might cause damage to the compactor or bodily injury.

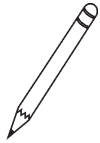

Whenever the compactor's vibration becomes weak or lost during normal operation regardless of operation hours, check the V-belt and clutch immediately.

Operating the Compactor on High Moisture Content Soil

Compactor traveling speed may drop on soils which contain clay, or other types of soil. Soil with high moisture content can cause the compaction plate to "stick" to the ground (not lifting up off the ground very fast or high).

To rectify this problem, consider the following:

- Check the bottom plate to see if clay or equivalent material has been lodged in the plate mechanism. If so, wash with water and remove.
- Remember the compactor does not work as efficiently on clay or soils that have a high moisture content level.
- If the soil has a high moisture level, dry soil to appropriate moisture content level or carry out compaction twice.

Using the Compactor Sprinkler System

The MVC-90H is equipped with a watering system that can be used to wet the ground during compaction to keep dust levels down.

To operate the watering system, turn the water cock handle to open the valve (Figure 18) and start the water flow. With the compactor at full speed and the water cock fully open, the water system will provide approximately 20 minutes of sprinkling.

WATER TANK CAP

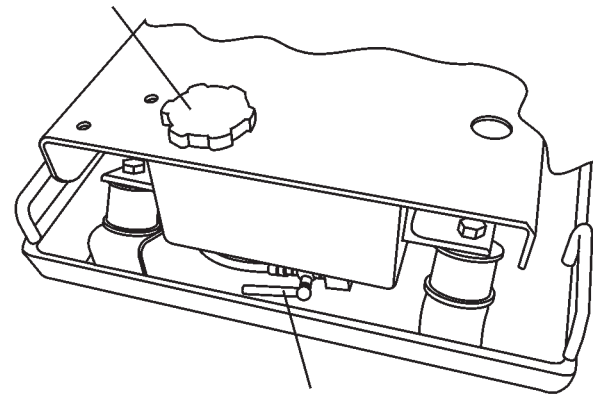

WATER COCK

Figure 18. Water System

MVC-90H PLATE COMPACTOR — MAINTENANCE

Maintenance

CAUTION - General Maintenance Safety

Inspection and other services should **always** be carried out on hard and level ground with the engine shutdown.

Inspection and Maintenance Service Tables.

To make sure your plate compactor is always in good working condition before using, carry out the maintenance inspection in accordance with Tables 5 through 7.

Daily Service

- Check for leakage of fuel or oil.
- Remove soil and clean the bottom of compaction plate.
- Check engine oil.
- Check for loose screws including tightness. See Table 5 below (tightening torque), for retightening:

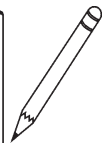
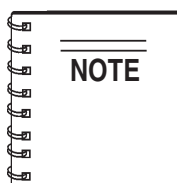

These inspection intervals are for operation under normal conditions. Adjust your inspection intervals based on the number hours plate compactor is in use, and particular working conditions.

TABLE 5. TIGHTENING TORQUE
(in. kg/cm) Diameter

Material	6mm	8mm	10mm	12mm	14mm	16mm	18mm	20mm
4T	70	150	300	500	750	1,100	1,400	2,000
6-8T	100	250	500	800	1,300	2,000	2,700	3,800
11T	150	400	800	1,200	2,000	2,900	4,200	5,600
*	100 (6mm)		300 ~ 350 (8mm)			650 ~ 700 (10mm)		

* (In case counter-part is of aluminum)

Material and quality of material is marked on each bolt, and screw.

Note: Threads in use with this machine are all right handed

TABLE 6. ENGINE INSPECTION

(For details, see separate Engine Manual)

Check Item	Hours of Operation
Fuel or Oil Leakage	Every 8 Hours (Daily)
Fastening Threads Tightness	Every 8 Hours (Daily)
Check/Replenish Engine Oil	Every 8 Hours (Daily)
Replace Engine Oil	First 20 hours, then every 100 hours
Check/Clean the Air Cleaner	Every 50 hours

TABLE 7. MVC-90H MACHINE INSPECTION

ITEM	HOURS OF OPERATION	REMARKS
Damaged Parts	Every 8 hours	Check Before Daily Operation
Loose or Lost Screws	Every 8 hours	Check Before Daily Operation
Function of Controlling System Part	Every 8 hours	Check Before Daily Operation
Vibrator Oil Check	Every 100 hours	See Page 21
Vibrator Oil Replacement	Every 300 hours	
V-belt & Clutch Check	Every 200 hours	See Page 22

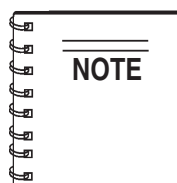

Fuel piping and connections should be replaced every 2 years.

Engine Oil Replacement:

1. Replace engine oil, in first 20 hours of operation and every 100 hours afterwards.
2. Oil may be drained more easily when it is warm after operation (For more details, see separate engine Owner's Manual).
3. When changing the engine oil, the old oil can be drained by removing the oil filler cap, and un-screwing the engine oil drain plug located at the base of the engine (Figure 19).
4. Remember to refill engine crankcase with the recommended type of oil as listed in Table 4.

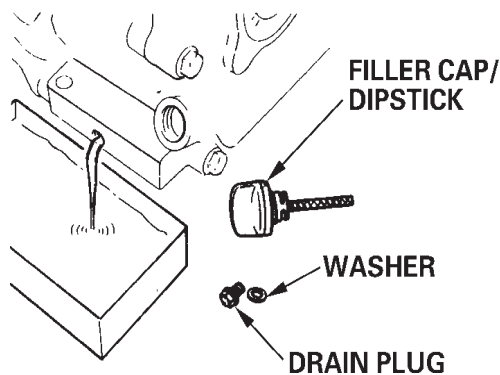
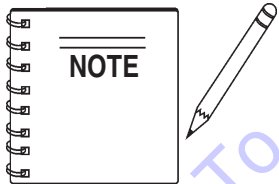

Figure 19. Engine Oil Plug

Changing Vibrator Oil

1. When changing the vibrator oil, remove the oil plug located at the bottom of the vibrator (Figure 19),
2. Tip the compactor to drain the oil.



Vibrator oil will drain more easily while it is warm.

Air Filter

1. The air filter element should be cleaned because a clogged air cleaner can cause poor engine starting, lack of power and shorten engine life substantially.
2. To clean or replace air filter loosen the wing nut on the air filter housing (Figure 20), remove the cover and take out air filter cartridge.

If only cleaning of the air filter is desired blow through the air filter cartridge from the inside, moving a jet of dry compressed air up and down until all dust is removed.

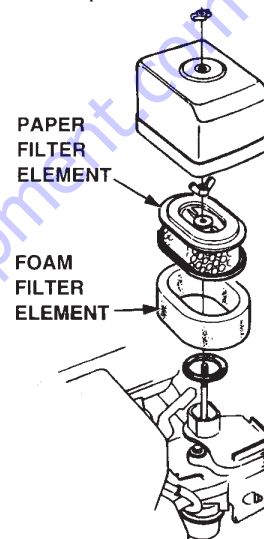

Figure 20. Air Filter

Replacing the V-belt

CAUTION - Checking and Replacing the V-Belt

NEVER attempt to check the V-belt with the engine running. Severe injury can occur if your hand gets caught between the V-belt and the clutch. Always use safety gloves.



1. Remove the belt cover.
2. Place an offset wrench (13 mm) or the like on the vibrator pulley (lower) fastening bolt.
3. Using a waste cloth or the like, pull the V-belt back strongly at midway of the belt on the left side and rotate the offset wrench clockwise so that the V-belt will come off.
4. Check the clutch and replace as necessary, following the procedures listed in **Checking the Clutch**.
5. Place the V-belt on the lower vibrator pulley. Push the V-belt to the left side of the upper clutch and rotate the offset wrench clockwise so that the V-belt moves onto the pulley.

Checking the Clutch

1. With belt cover removed, visually check outer drum of the clutch for seizure and "V" groove for wear or damage.
2. Clean the "V" groove as necessary.
3. Check the clutch lining and shoe for signs of wear. If the shoe is worn, replace the clutch to prevent deficient power transmission and slippage.

Replacing the Clutch

1. Remove V-belt.
2. Remove bolt at engine power output by tapping an engaged wrench (e.g. tapping with hammer) and rotate the bolt counterclockwise.
3. Remove clutch with a pulley extractor.
4. To install a new clutch, reverse steps 1-3.

MVC-90H PLATE COMPACTOR — PREPARATION FOR LONG-TERM STORAGE

Compactor Storage

For storage of the compactor for over 30 days, the following is required:

- Drain the fuel tank completely.
- Run the engine until the fuel in the injection system is completely consumed.
- Completely drain the oil from the engine crankcase and follow procedures described in the engine Owner's Manual for engine storage.
- Completely drain the compactor's hydraulic oil from the vibrating case.
- Clean entire plate compactor, especially the bottom plate removing all dirt and foreign matter.
- Cover plate compactor and engine with plastic covering or equivalent and store in a clean, dry place.

To order go to Discount-Equipment.com

MVC-90H PLATE COMPACTOR — TROUBLESHOOTING (ENGINE)

Practically all breakdowns can be prevented by proper handling and maintenance inspections, but in the event of a breakdown, please take a remedial action following the diagnosis based on the Engine Troubleshooting (Table 8) information shown below and on the following page. If the problem cannot be remedied, please leave the unit just as it is and consult our company's business office or service plant.

TABLE 8. ENGINE TROUBLESHOOTING

SYMPTOM	POSSIBLE CAUSE	SOLUTION
Difficult to start, "fuel is available, but no SPARK at spark plug".	Spark plug bridging?	Check gap, insulation or replace spark plug.
	Carbon deposit on spark plug?	Clean or replace spark plug.
	Short circuit due to deficient spark plug insulation?	Check spark plug insulation, replace if worn.
	Improper spark plug gap?	Set to proper gap.
Difficult to start, "fuel is available, and SPARK is present at the spark plug".	ON/OFF switch is shorted?	Check switch wiring, replace switch.
	Ignition coil defective?	Replace ignition coil.
	Improper spark gap, points dirty?	Set correct spark gap and clean points.
	Condenser insulation worn or short circuiting?	Replace condenser.
	Spark plug wire broken or short circuiting?	Replace defective spark plug wiring.
Difficult to start, "fuel is available, spark is present and compression is normal"	Wrong fuel type?	Flush fuel system, and replace with correct type of fuel.
	Water or dust in fuel system?	Flush fuel system.
	Air cleaner dirty?	Clean or replace air cleaner.
Difficult to start, "fuel is available, spark is present and compression is low"	Suction/exhaust valve stuck or protruded?	Re-seat valves.
	Piston ring and/or cylinder worn?	Replace piston rings and or piston.
	Cylinder head and/or spark plug not tightened properly?	Torque cylinder head bolts and spark plug.
	Head gasket and/or spark plug gasket damaged?	Replace head and spark plug gaskets.
No fuel present at carburetor.	Fuel not available in fuel tank?	Fill with correct type of fuel.
	Fuel cock does not open properly?	Apply lubricant to loosen fuel cock lever, replace if necessary.
	Fuel filter clogged?	Replace fuel filter.
	Fuel tank cap breather hole clogged?	Clean or replace fuel tank cap.
	Air in fuel line?	Bleed fuel line.

MVC-90H PLATE COMPACTOR — TROUBLESHOOTING (ENGINE)

TABLE 8. ENGINE TROUBLESHOOTING (CONTINUED)

SYMPTOM	POSSIBLE CAUSE	SOLUTION
"Weak in power" compression is proper and does not misfire.	Air cleaner not clean?	Clean or replace air cleaner
	Improper level in carburetor?	Check float adjustment, re-build carburetor.
	Defective Spark plug?	Clean or replace spark plug.
	Defective Spark plug?	
"Weak in power" compression is proper but misfires.	Water in fuel system?	Flush fuel system, and replace with correct type of fuel.
	Dirty spark plug?	Clean or replace spark plug.
	Ignition coil defective?	Replace ignition coil.
Engine overheats.	Spark plug heat value improper?	Replace with correct type of spark plug.
	Correct type of fuel?	Replace with correct type of fuel
	Cooling fins dirty?	Clean cooling fins.
Rotational speed fluctuates.	Governor adjusted correctly?	Adjust governor.
	Governor spring defective?	Replace governor spring.
	Fuel flow restricted?	Check entire fuel system for leaks or clogs.
Recoil starter malfunction.	Recoil mechanism clogged with dust and dirt?	Clean recoil assembly with soap and water.
	Spiral spring loose?	Replace spiral spring.

MVC-90H PLATE COMPACTOR — TROUBLESHOOTING (PLATE COMPACTOR)

Practically all breakdowns can be prevented by proper handling and maintenance inspections, but in the event of a breakdown, please take a remedial action following the diagnosis based on the Plate Compactor Troubleshooting (Table 9) information shown below and on the following page. If the problem cannot be remedied, please leave the unit just as it is and consult our company's business office or service plant.

TABLE 9. PLATE COMPACTOR TROUBLESHOOTING

SYMPTOM	POSSIBLE CAUSE	SOLUTION
Travel speed too low, and vibration is weak.	Engine speed too low?	Set engine speed to correct RPM.
	Clutch slips?	Check or replace clutch.
	V-belt slips?	Adjust or replace V-belt.
	Excessive oil in vibrator?	Drain excess oil and fill to proper level.
	Malfunction in vibrator housing?	Check eccentric, gears and counter weights.
Does not travel forward.	V-belt slips?	Replace V-belt.
	Clutch slips?	Check clutch springs and shoes.
	Vibrator locked?	Check vibrator housing (eccentric, gears and counterweights)

TO PURCHASE THIS PRODUCT PLEASE CONTACT US



**Equipment Financing and
Extended Warranties Available**



**Discount-Equipment.com is your online resource for
commercial and industrial quality parts and equipment sales.**

561-964-4949

visit us on line @ www.discount-equipment.com

Select an option below to find your Equipment

Search by Manufacturer

Search by Product Type

Request a Quote

We sell worldwide for the brands: Genie, Terex, JLG, MultiQuip, Mikasa, Essick, Whiteman, Mayco, Toro Stone, Diamond Products, Generac Magnum, Airman, Haulotte, Barreto, Power Blanket, Nifty Lift, Atlas Copco, Chicago Pneumatic, Allmand, Miller Curber, Skyjack, Lull, Skytrak, Tsurumi, Husquvarna Target, Stow, Wacker, Sakai, Mi-T-M, Sullair, Basic, Dynapac, MBW, Weber, Bartell, Bennar Newman, Haulotte, Ditch Runner, Menegotti, Morrison, Contec, Buddy, Crown, Edco, Wyco, Bomag, Laymor, EZ Trench, Bil-Jax, F.S. Curtis, Gehl Pavers, Heli, Honda, ICS/PowerGrit, IHI, Partner, Imer, Clipper, MMD, Koshin, Rice, CH&E, General Equipment, Amida, Coleman, NAC, Gradall, Square Shooter, Kent, Stanley, Tamco, Toku, Hatz, Kohler, Robin, Wisconsin, Northrock, Oztec, Toker TK, Rol-Air, APT, Wylie, Ingersoll Rand / Doosan, Innovatech, Con X, Ammann, Mecalac, Makinex, Smith Surface Prep, Small Line, Wanco, Yanmar

OPERATION MANUAL

HERE'S HOW TO GET HELP

PLEASE HAVE THE MODEL AND SERIAL
NUMBER ON-HAND WHEN CALLING

To order go to Discount-Equipment.com

Your Local Dealer is:



www.Discount-Equipment.com

