



REVISED STARTING
SERIAL # 120110115

PARTS LIST MANUAL ELECTRIC POWER TROWELS



SKU #	MODEL #	SIZE	RPM	MOTOR OPTION
C86400	T244RS-1.5	24"	65**	LEESON 1.5HP 1-PH 60HZ 115V 1725RPM
C85100	T304RS-1.5	30"	65**	
81300	T364-3	36"	115*	BALDOR 3HP 1-PH 60HZ 230V 3450RPM
81200	T464-5	46"	105*	BALDOR 5HP 1-PH 60Hz 230V 3450RPM

*STANDARD SPEED CONCRETE POWER TROWELS

**REDUCED SPEED EPOXY MORTAR POWER TROWELS



A Division of Equipment Development Company, Inc.

PARTS FINDER

**Search Website
by Part Number**



**Search Manual
Library For Parts
Manual & Lookup Part
Numbers – Purchase
or Request Quote**

Search Manuals

Enter your information to help us find the right manual for your machine.

* Brand:

* Model:

* Serial:

* Part Number:

SEARCH

**Can't Find Part or
Manual? Request Help
by Manufacturer,
Model & Description**

Parts Order Form

Please fill in the following information to help us find the right part for your machine.

Manufacturer:	<input type="text"/>
Model:	<input type="text"/>
Description:	<input type="text"/>
Part Number:	<input type="text"/>
Quantity:	<input type="text"/>
Notes:	<input type="text"/>

Submit

Discount-Equipment.com is your online resource for quality parts & equipment.

Florida: **561-964-4949** Outside Florida TOLL FREE: **877-690-3101**

Need parts?

Click on this link: <http://www.discount-equipment.com/category/5443-parts/> and choose one of the options to help get the right parts and equipment you are looking for. Please have the machine model and serial number available in order to help us get you the correct parts. If you don't find the part on the website or on one of the online manuals, please fill out the request form and one of our experienced staff members will get back to you with a quote for the right part that your machine needs.

We sell worldwide for the brands: Genie, Terex, JLG, MultiQuip, Mikasa, Essick, Whiteman, Mayco, Toro Stone, Diamond Products, Generac Magnum, Airman, Haulotte, Barreto, Power Blanket, Nifty Lift, Atlas Copco, Chicago Pneumatic, Allmand, Miller Curber, Skyjack, Lull, Skytrak, Tsurumi, Husquvarna Target, Stow, Wacker, Sakai, Mi-T-M, Sullair, Basic, Dynapac, MBW, Weber, Bartell, Bennar Newman, Haulotte, Ditch Runner, Menegotti, Morrison, Contec, Buddy, Crown, Edco, Wyco, Bomag, Laymor, EZ Trench, Bil-Jax, F.S. Curtis, Gehl Pavers, Heli, Honda, ICS/PowerGrit, IHI, Partner, Imer, Clipper, MMD, Koshin, Rice, CH&E, General Equipment, Amida, Coleman, NAC, Gradall, Square Shooter, Kent, Stanley, Tamco, Toku, Hatz, Kohler, Robin, Wisconsin, Northrock, Oztec, Toker TK, Rol-Air, APT, Wylie, Ingersoll Rand / Doosan, Innovatech, Con X, Ammann, Mecalac, Makinex, Smith Surface Prep, Small Line, Wanco, Yanmar

READ AND UNDERSTAND THE OPERATORS INSTRUCTION MANUAL *THOROUGHLY* BEFORE ATTEMPTING TO OPERATE THIS EQUIPMENT.



Death or serious injury could occur if this machine is used improperly.



SAFETY MESSAGES

- Safety Instructions are preceded by a graphic alert symbol of DANGER, WARNING, or CAUTION.

DANGER

Indicates an imminent hazard which, if not avoided, will result in death or serious injury.

WARNING

Indicates an imminent hazard which, if not avoided, can result in death or serious injury.

CAUTION

Indicates hazards which, if not avoided, could result in serious injury and or damage to the equipment.

GASOLINE/PROPANE POWERED EQUIPMENT

WARNING

- Engine exhaust from this product contains chemicals known to the State of California to cause cancer, birth defects or other reproductive harm.



- Gasoline is extremely flammable and poisonous. It should only be dispensed in well ventilated areas, and with a cool engine.

- Small gasoline engines produce high concentrations of carbon monoxide (CO) example: a 5 HP 4 cycle engine operation in an enclosed 100,000 cu. ft. area with only one change of air per hour is capable of providing deadly concentrations of CO in less than fifteen minutes. Five changes of air in the same area will produce noxious fumes in less than 30 minutes. Gasoline or propane powered equipment should not be used in enclosed or partially enclosed areas. Symptoms of CO poisoning include, headache, nausea, weakness, dizziness, visual problems and loss of consciousness. If symptoms occur - get into fresh air and seek medical attention immediately.

ELECTRICAL POWERED EQUIPMENT



Extreme care must be taken when operating electric models with water present: Ensure power cord is properly grounded, is attached to a Ground-Fault-Interrupter (GFI) outlet, and is undamaged.

- Check all electrical cables - be sure connections are tight and cable is continuous and in good condition. Be sure cable is correctly rated for both the operating current and voltage of this equipment.
- Improper connection of the equipment-grounding conductor can result in a risk of electric shock. Check with qualified electrician or service person if there is any doubt as to whether the outlet is properly grounded. Adhere to all local codes and ordinances.
- **NOTE:** In the event of a malfunction or breakdown, grounding provides a path of least resistance for the electric current to dissipate. The motor is equipped with a grounded plug and must be connected to an outlet that is properly installed and properly grounded. DO NOT modify the plug provided on the motor. If the plug does not fit the outlet have a qualified electrician install the proper receptacle.
- Switch motor OFF **before** disconnecting power.

- Do not disconnect power by pulling cord. To disconnect, grasp the plug, not the cord.
- Unplug power cord at the machine when not in use and before servicing.

GENERAL INSTRUCTIONS

- Equipment should only be operated by trained personnel in good physical condition and mental health (not fatigued). The operator and maintenance personnel must be physically able to handle the bulk weight and power of this equipment.
- This is a one person tool. Maintain a safe operating distance to other personnel. It is the **operators' responsibility** to keep other people (workers, pedestrians, bystanders, etc.) away during operation. Block off the work area in all directions with roping, safety netting, etc. for a safe distance. Failure to do so may result in others being injured by flying debris or exposing them to harmful dust and noise.
- This equipment is intended for commercial use only.
- For the operator's safety and the safety of others, always keep all guards in place during operation.
- Never let equipment run unattended.



- Personal Protection Equipment and proper safety attire must be worn when operating this machinery. The operator must wear approved safety equipment appropriate for the job such as hard hat and safety shoes when conditions require. Hearing protection **MUST** be used (operational noise levels of this equipment may exceed 90db). Eye protection **MUST** be worn at all times.



Keep body parts and loose clothing away from moving parts. Failure to do so could result in dismemberment or death.

- Do not modify the machine.
 - Stop motor/engine when adjusting or servicing this equipment.
- Maintain a safe operating distance from flammable materials. Sparks from the cutting-action of this machine can ignite flammable materials or vapors.

DUST WARNING

WARNING

Some dust created by power sanding, sawing, grinding, drilling, and other construction activities contains chemicals known to cause cancer, birth defects, or other reproductive harm. Some examples of these chemicals are:

- Lead from lead-based paints, and
 - Crystalline silica from bricks and concrete and other masonry products.
- Your risk of exposure to these chemicals varies depending on how often you do this type of work. To reduce your risk: work in a well ventilated area, use a dust control system, such as an industrial-style vacuum, and wear approved personal safety equipment, such as a dust/particle respirator designed to filter out microscopic particles.

PARTS LIST MANUAL

ELECTRIC POWER TROWELS

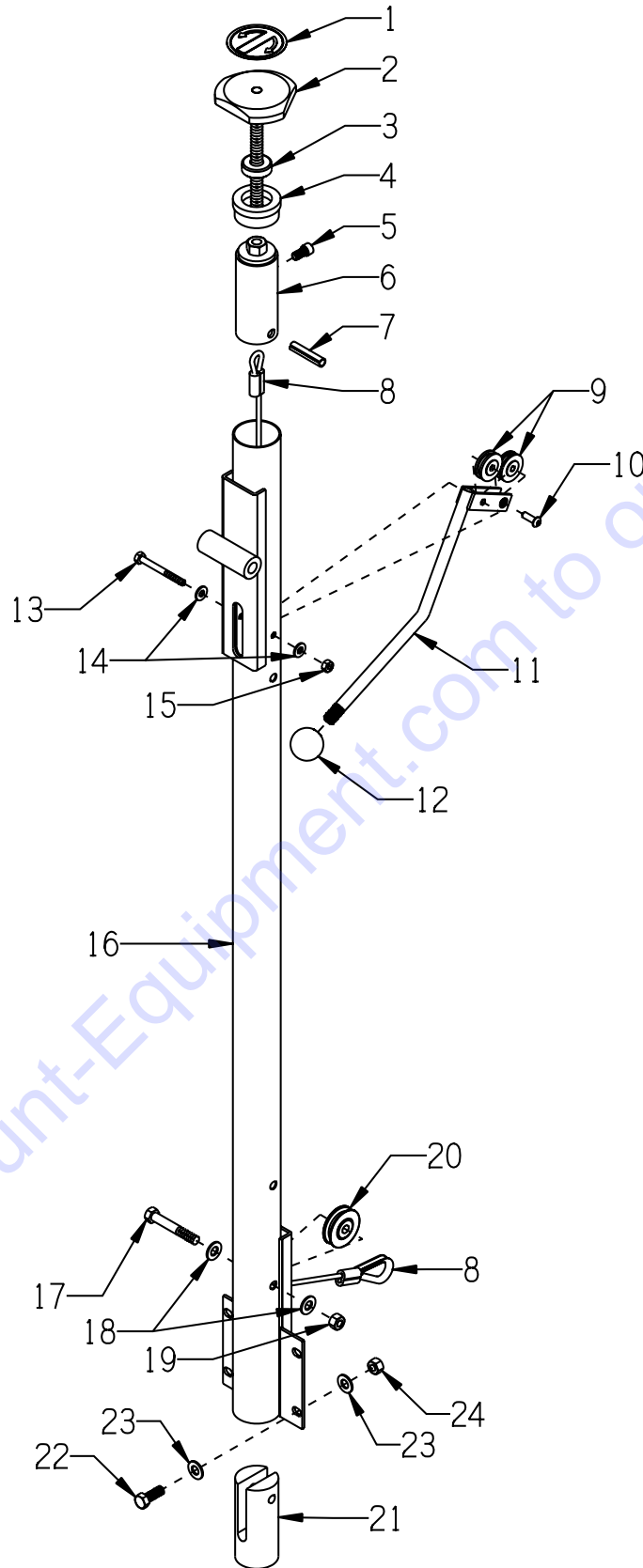
TABLE OF CONTENTS

<u>Section</u>	<u>Page Number</u>
Safety Messages and General Instructions	2
How To Order Replacement Parts	3
Illustration 1: Handle Bar, Pitch Lever & Control Knob Grouping	4, 5
Illustration 2: Adjustable Handle Belly Bar Grouping	6
Illustration 3: On/Off Switch Grouping	7
Illustration 4: Frame, Transmission & Spider Grouping	8, 9
Illustration 5: Spider Assembly	10
Illustration 6: Bolt-On Blades & Adapter for 24" Trowel	11
Illustration 7: Bolt-On Blades & Adapter for 30" Trowel	12
Illustration 8: Bolt-On Blades & Adapter for 36" Trowel	13
Illustration 9: Bolt-On Blades & Adapter for 46" Trowel	14
Illustration 10: Optional Quick Change Blades & Adapters	15
Illustration 11: Lift Handle Grouping	16
Illustration 12: Optional "Tote-A-Trowel"	17
Illustration 13: Motor Grouping for Model T244RS-1.5 & T304RS-1.5	18, 19
Illustration 14: Motor Grouping for Model T364-3	20, 21
Illustration 15: Motor Grouping for Model T464-5	22, 23
Wiring Diagram for Starter & Switch	24
Wiring Diagram for Leeson 1.5 HP Motor	25
Wiring Diagram for Baldor 3 HP Motor	26
Wiring Diagram for Baldor 5 HP Motor	27
Limited Equipment Warranty of Sale - Terms & Conditions	28 (Back Page)



A Division of Equipment Development Company, Inc.

ILLUSTRATION 1: HANDLE BAR, PITCH LEVER & CONTROL KNOB GROUPING

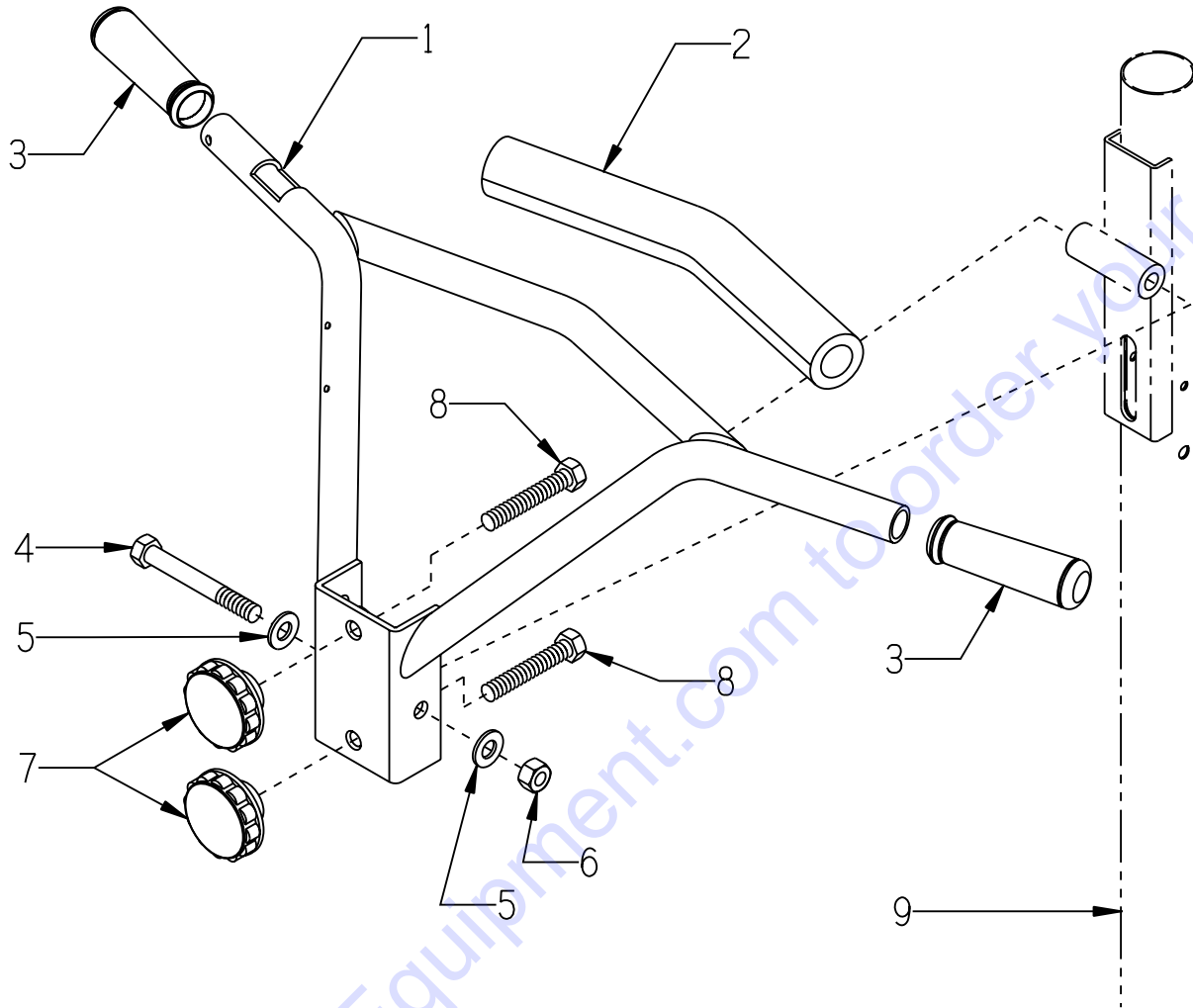


**PARTS LISTING - ILLUSTRATION 1 :
HANDLE BAR, PITCH LEVER & CONTROL KNOB GROUPING**

ITEM #	PART #	DESCRIPTION	QTY.
1	3661	DECAL, BLADE ANGLE - FLAT/TILT	1
2	49014	KNOB, CONTROL W/ 1/2-13 X 6-3/4" ROD	1
3	3642	BEARING, THRUST BALL 1/2	1
4	36078	HANDLE TOP INSERT	1
5	11639	SCREW, SKT. HD. CAP 5/16-18 X 5/8	1
6	36080	LINKAGE	1
7	11728	PIN, ROLL 3/8 X 1-3/4	1
8	36082	CABLE, CONTROL 3/16 X 51"L	1
	4610	CABLE, THIMBLE 3/16"	1
	3618	SLEEVE, NICOPRESS DOUBLE 3/16"	2
9	14082	PULLEY BEARING 1-1/4DIA. X 1/4BORE	2
10	10884	SCREW, SKT. BUTTON HD. 1/4-20 X 3/4	1
11	36081	LEVER, PITCH	1
12	14023	KNOB, BALL 1-3/8 W/ 1/2-13THD, BLK.	1
13	10001	SCREW, CAP 1/4-20 X 2-1/2	1
14	10602	WASHER, FLAT 1/4 SAE ZINC	2
15	10150	NUT, HEX NYLON LOCK 1/4-20	1
16	36070E	HANDLE BAR	1
17	10393	SCREW, CAP 3/8-24 X 2-1/2	1
18	10025	WASHER, FLAT 3/8 SAE ZINC	2
19	10058	NUT, HEX LOCK 3/8-24 W/ NYLON PATCH	1
20	3621	PULLEY BEARING 1-3/4DIA. X 3/8BORE	1
21	36077	ROLLER GUIDE	1
22	10021	SCREW, CAP 3/8-24 X 1	4
23	10025	WASHER, FLAT 3/8 SAE ZINC	4
24	10004	NUT, HEX LOCK 3/8-24 ZINC	4

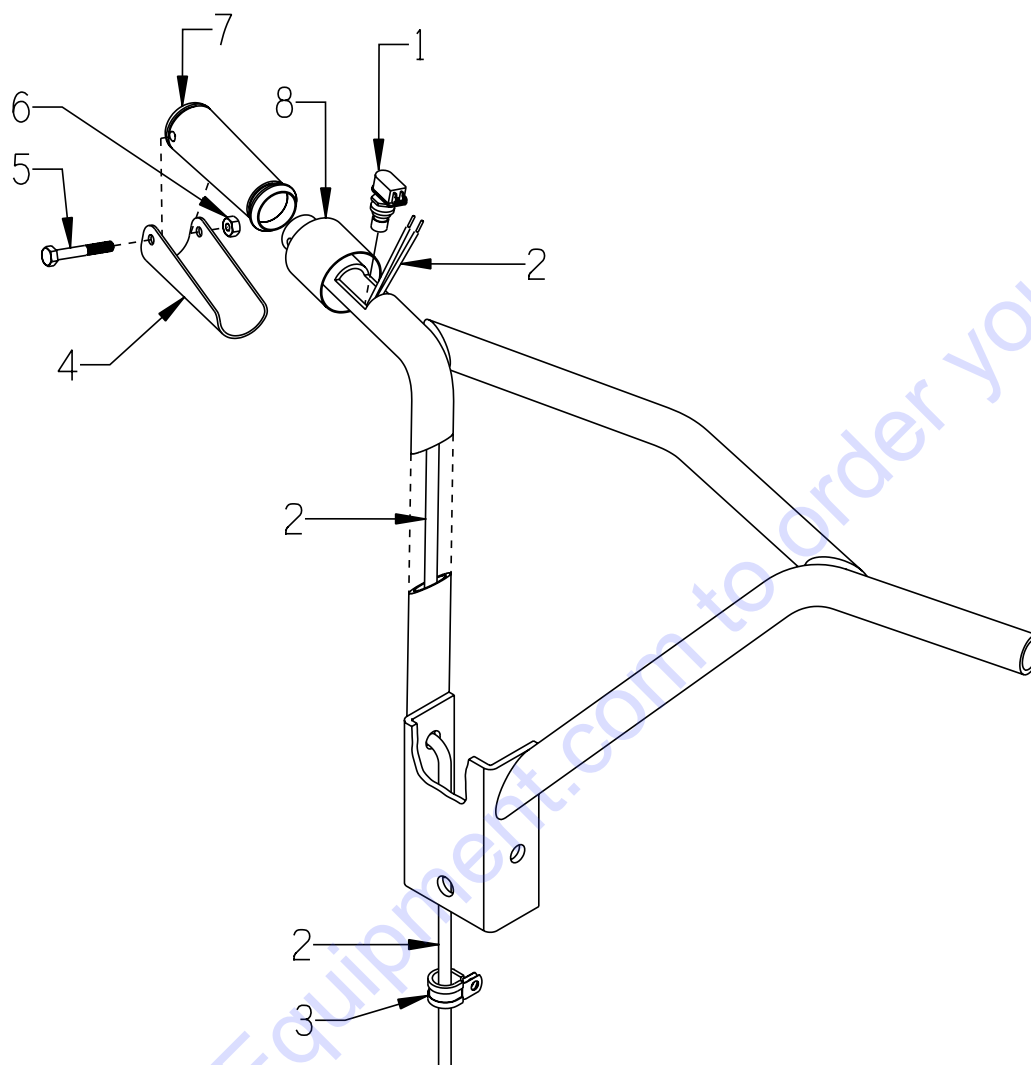


ILLUSTRATION 2 : ADJUSTABLE HANDLE BELLY BAR GROUPING



ITEM #	PART #	DESCRIPTION	QTY.
1	36071E	HANDLE BELLY BAR, ADJUSTABLE	1
2	36083	PADDING, BELLY BAR	1
3	10608	GRIP, HAND 1" MODEL AT	2
4	81001	SCREW, CAP 1/2-13 X 4	1
5	10312	WASHER, FLAT 1/2 SAE ZINC	2
6	10155	NUT, HEX NYLON LOCK 1/2-13	1
7	36063	KNOB, FLUTED 1/2-13 X 2-1/2"DIA.	2
8	10340	BOLT, TAP 1/2-13 X 3 (FULL THREAD)	2
9	36070E	HANDLE BAR (REF. TO ILLUS. 1, ITEM 16)	1

ILLUSTRATION 3: ON/OFF SWITCH GROUPING

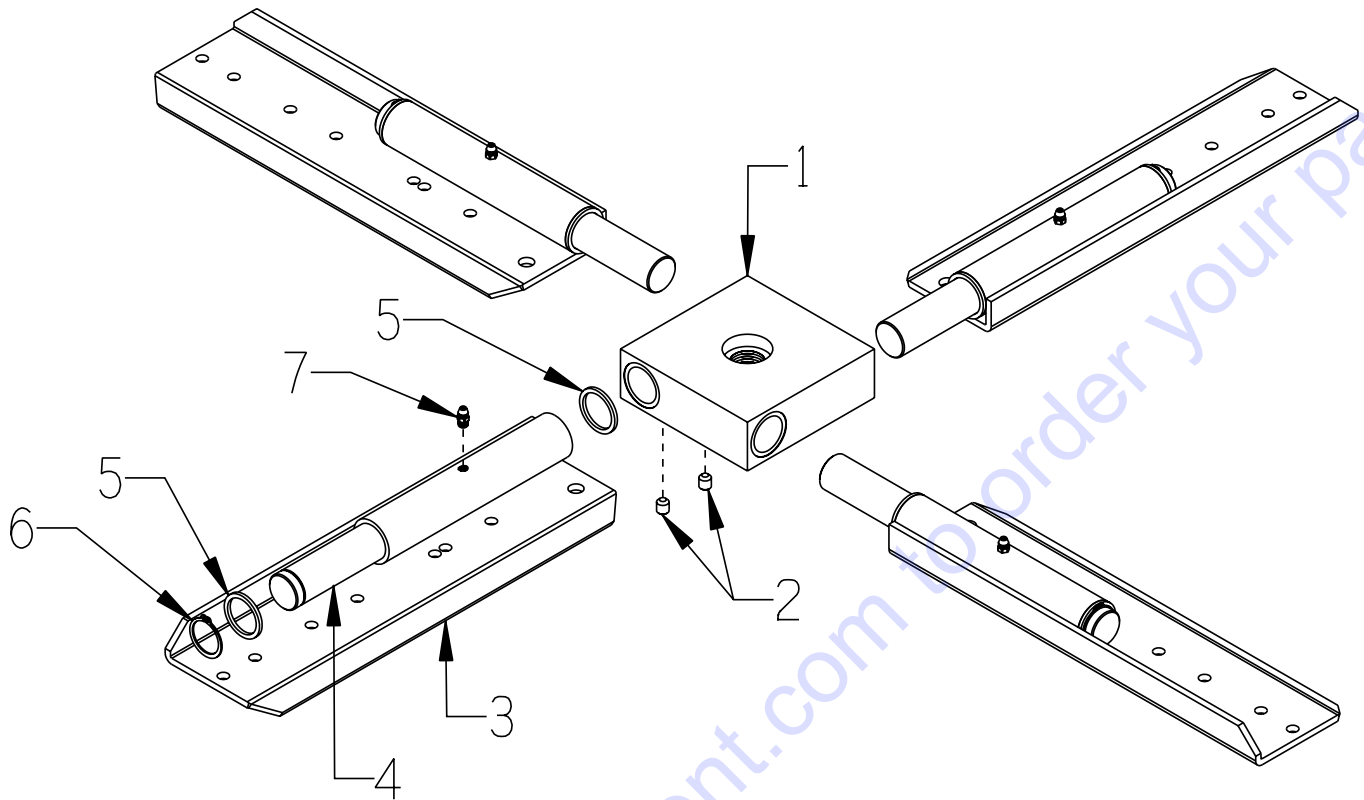


ITEM #	PART #	DESCRIPTION	QTY.
1	36094	SWITCH, ON/OFF PUSH-BUTTON	1
2	36135	CORD WIRE 16/2 X 60"L (SWITCH TO CONN.)	1
3	11690	CLAMP, LOOM, 3/8"	1
4	3699	LEVER 3-3/4"	1
5	10314	SCREW, CAP 1/4-20 X 1-3/4	1
6	10015	NUT, HEX LOCK 1/4-20 ZINC	1
7	-----	MODIFIED GRIP (REF. TO ILLUS. 2, ITEM 3)	1
8	36136	TUBING, HEAT SHRINK, TROWEL GRIP	1

PARTS LISTING - ILLUSTRATION 4 : FRAME, TRANSMISSION & SPIDER GROUPING			
ITEM #	PART #	DESCRIPTION	QTY.
1	36065 36066 36067 36068	FRAME & GUARD RING 24" TROWEL 30" TROWEL 36" TROWEL 46" TROWEL	1
2	11729	BOLT, TAP 3/8-24 X 1-3/4 FULL THD.	4
3	10025	WASHER, FLAT 3/8 SAE ZINC	8
4	10004	NUT, HEX LOCK 3/8-24 ZINC	4
5	36069	MOUNT, TRANSMISSION	1
6	10055	SCREW, CAP 3/8-16 X 1	6
7	10025	WASHER, FLAT 3/8 SAE ZINC	6
8	3664	TRANSMISSION SUBASSY. (20:1 RATIO)	1
9	3609	BEARING, THRUST BALL 1-1/2"ID X 2-19/32"OD X 5/8"THK	1
10	3626 4603	PLATE, PITCH ADJUSTMENT 24, 30, & 36" TROWELS 46" TROWELS	1
11	10021 10322	SCREW, CAP SCREW, CAP 3/8-24 X 1 (24, 30, & 36" TROWELS) SCREW, CAP 1/2-20 X 2 (46" TROWELS, ON INSIDE)	4
12	3605 4805	ROD END, MALE 3/8-24 (24, 30, & 36" TROWELS, AS SHOWN) 1/2-20 (46" TROWELS, MOUNTED ON OUTSIDE)	4
13	10004 10205	NUT, HEX LOCK ZINC 3/8-24 (24, 30, & 36" TROWELS) 1/2-20 (46" TROWELS)	12 16
14	10025 10312	WASHER, FLAT ZINC 3/8 SAE (24, 30, & 36" TROWELS) 1/2 SAE (46" TROWELS)	8
15	36084 36085 36086 36087 36093	SPIDER ASSEMBLY (REFER TO ILLUS. 5) 24" TROWEL (8-1/2" ARMS) 30" TROWEL (12" ARMS) 36" TROWEL (13" ARMS) 46" TROWEL (15-1/4" ARMS) 46" TROWEL (17-1/4" ARMS)	1
16	3625	FORK	1
17	10816	SCREW, CAP 3/8-24 X 1-1/2	1
18	10030	SCREW, CAP 3/8-24 X 2	1
19	10004	NUT, HEX LOCK 3/8-24 ZINC	2

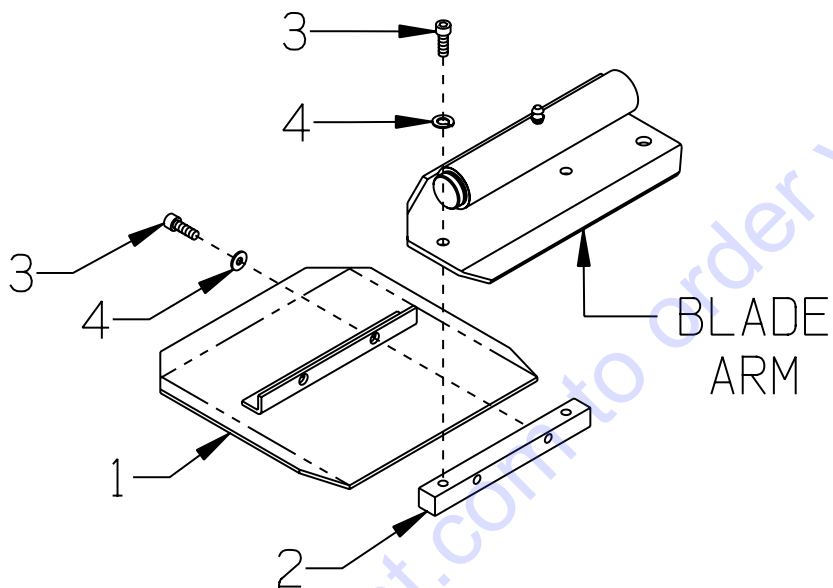


ILLUSTRATION 5: SPIDER ASSEMBLY



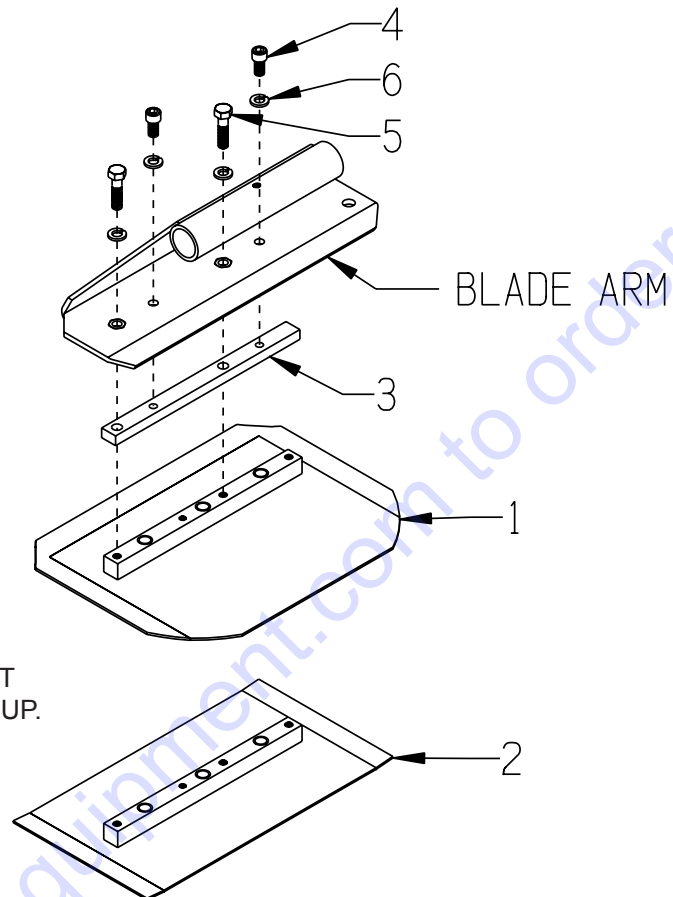
ITEM #	PART #	DESCRIPTION	QTY.
1	3637	HUB, 4 BLADE TROWEL	1
2	10052	SCREW, SET 5/16-18 X 3/8	8
3		ARM, BLADE	4
	2402	8-1/2" ARM, 24" TROWEL ,BOLT-ON BLADES	
	3666	12" ARM, 30" TROWEL, BOLT-ON OR QUICK-CHANGE	
	36007	13" ARM, 36" TROWEL, BOLT-ON OR QUICK-CHANGE	
	4618	15-1/4" ARM, 46" TROWEL, BOLT-ON BLADES	
	4606	17-1/4" ARM, 46" TROWEL, QUICK-CHANGE BLADES	
4		SHAFT, BLADE ARM	4
	3635	9-11/16"L SHAFT (24", 30", & 36" TROWEL)	
	4604	13-15/16"L SHAFT (46" TROWEL)	
5	3629	SPACER, ALUM. 1.25 X 1.017 X .090	8
6	10906	RETAINING RING, EXT. 1"	4
7	10808	FITTING, GREASE 1/4-28 STRAIGHT	4

ILLUSTRATION 6:
BOLT-ON BLADES & ADAPTER
FOR 24" TROWEL



ITEM #	PART #	DESCRIPTION	QTY.
1		BLADE	4
	40470	C-4 COMBINATION TROWEL BLADE 8 X 8 (SHOWN)	
	40480	F-4 FINISH TROWEL BLADE 6 X 8	
	40490	M-4 FLOAT TROWEL BLADE 9 X 8	
2	2406	BAR, BLADE MOUNTING 5/8"SQ. X 6"	4
3	11639	SCREW, SKT. HD. CAP 5/16-18 X 5/8	16
4	10801	WASHER, LOCK 5/16 ZINC	16

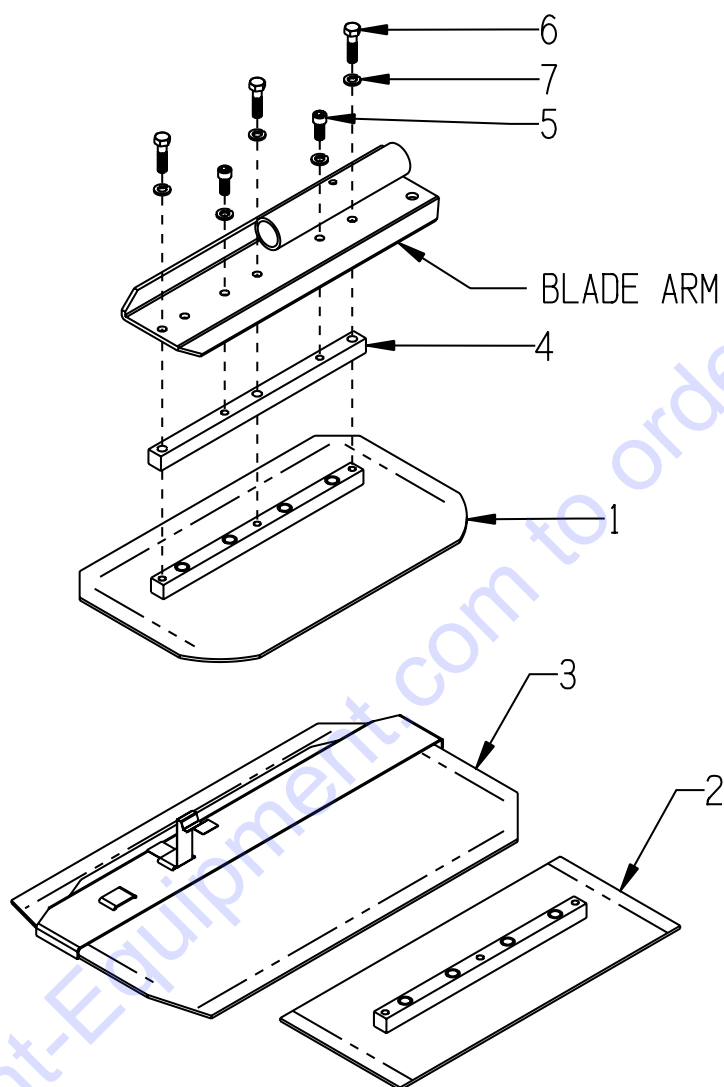
ILLUSTRATION 7:
BOLT-ON BLADES & ADAPTER
FOR 30" TROWEL



NOTE:
A FLOAT BLADE IS NOT
USED WITH THIS SET-UP.

ITEM #	PART #	DESCRIPTION	QTY.
1	40270-C	C-2C COMBINATION TROWEL BLADE 8 X 10-1/2	4
2	40280-C	F-2C FINISH TROWEL BLADE 6 X 10-1/2	4
3	3639	ADAPTER BAR 3/8" X 5/8" X 8-1/4"	4
4	11639	SCREW, SKT. HD. CAP 5/16-18 X 5/8	8
5	10606	SCREW, HEX HD. CAP 5/16-18 X 1-1/4	8
6	10801	WASHER, LOCK 5/16 ZINC	20

ILLUSTRATION 8:
BOLT-ON BLADES & ADAPTER
FOR 36" TROWEL



ITEM #	PART #	DESCRIPTION	QTY.
1	40040-C	C-1C COMBINATION TROWEL BLADE 8 X 14	4
2	40050-C	F-1C FINISH TROWEL BLADE 6 X 14	4
3	40060-CE	M-1CE FLOAT TROWEL BLADE 10 X 14 (SLIPS OVER FINISH BLADE)	4
4	36016	ADAPTER BAR 5/8" SQ. X 10-1/4"	4
5	11639	SCREW, SKT. HD. CAP 5/16-18 X 5/8	8
6	10606	SCREW, HEX HD. CAP 5/16-18 X 1-1/4	12
7	10801	WASHER, LOCK 5/16 ZINC	20



A Division of Equipment Development Company, Inc.

PARTS FINDER

**Search Website
by Part Number**



**Search Manual
Library For Parts
Manual & Lookup Part
Numbers – Purchase
or Request Quote**

Search Manuals

Enter your information to help us find the right parts manual for your machine.

* Brand:

* Model:

* Serial:

* Part Number:

SEARCH

**Can't Find Part or
Manual? Request Help
by Manufacturer,
Model & Description**

Parts Order Form

Please fill in the following information to help us find the right part for your machine.

Manufacturer:	<input type="text"/>
Model:	<input type="text"/>
Description:	<input type="text"/>
Part Number:	<input type="text"/>
Quantity:	<input type="text"/>
Notes:	<input type="text"/>

Discount-Equipment.com is your online resource for quality parts & equipment.

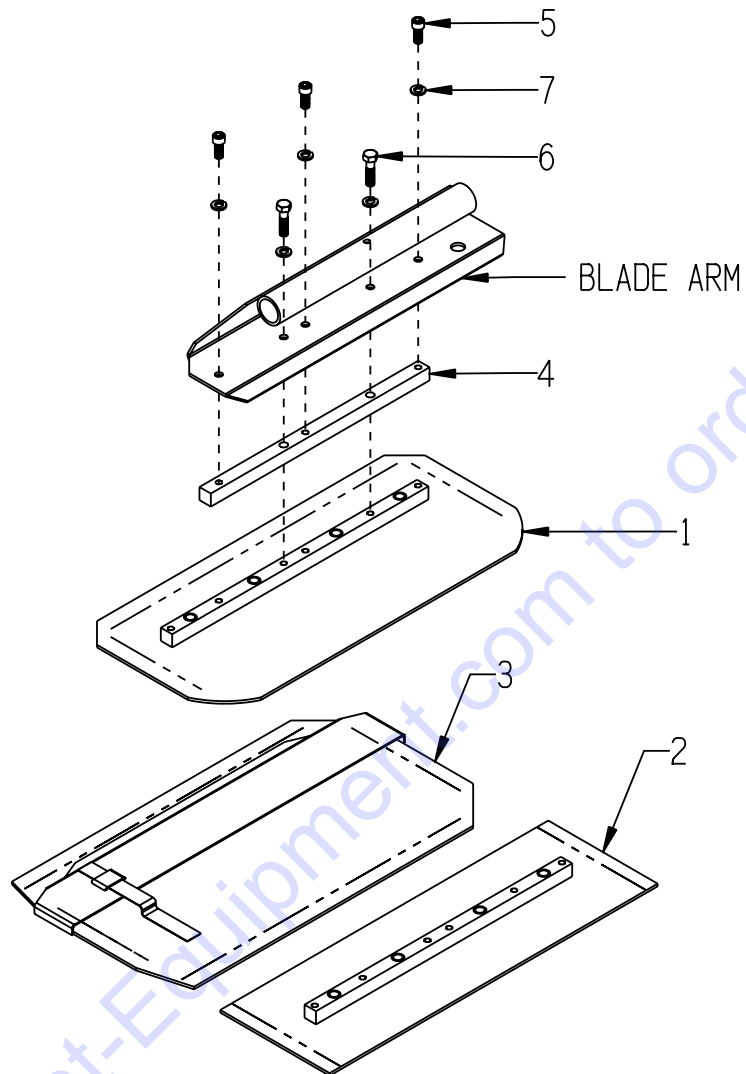
Florida: **561-964-4949** Outside Florida TOLL FREE: **877-690-3101**

Need parts?

Click on this link: <http://www.discount-equipment.com/category/5443-parts/> and choose one of the options to help get the right parts and equipment you are looking for. Please have the machine model and serial number available in order to help us get you the correct parts. If you don't find the part on the website or on one of the online manuals, please fill out the request form and one of our experienced staff members will get back to you with a quote for the right part that your machine needs.

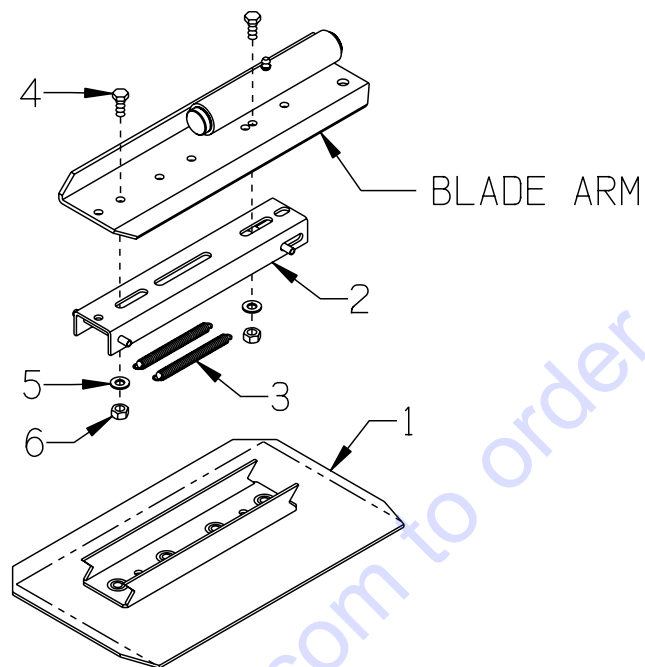
We sell worldwide for the brands: Genie, Terex, JLG, MultiQuip, Mikasa, Essick, Whiteman, Mayco, Toro Stone, Diamond Products, Generac Magnum, Airman, Haulotte, Barreto, Power Blanket, Nifty Lift, Atlas Copco, Chicago Pneumatic, Allmand, Miller Curber, Skyjack, Lull, Skytrak, Tsurumi, Husquvarna Target, Stow, Wacker, Sakai, Mi-T-M, Sullair, Basic, Dynapac, MBW, Weber, Bartell, Bennar Newman, Haulotte, Ditch Runner, Menegotti, Morrison, Contec, Buddy, Crown, Edco, Wyco, Bomag, Laymor, EZ Trench, Bil-Jax, F.S. Curtis, Gehl Pavers, Heli, Honda, ICS/PowerGrit, IHI, Partner, Imer, Clipper, MMD, Koshin, Rice, CH&E, General Equipment, Amida, Coleman, NAC, Gradall, Square Shooter, Kent, Stanley, Tamco, Toku, Hatz, Kohler, Robin, Wisconsin, Northrock, Oztec, Toker TK, Rol-Air, APT, Wylie, Ingersoll Rand / Doosan, Innovatech, Con X, Ammann, Mecalac, Makinex, Smith Surface Prep, Small Line, Wanco, Yanmar

ILLUSTRATION 9:
BOLT-ON BLADES & ADAPTER
FOR 46" TROWEL



ITEM #	PART #	DESCRIPTION	QTY.
1	40070-C	C-3C COMBINATION TROWEL BLADE 8 X 18	4
2	40080-C	F-3C FINISH TROWEL BLADE 6 X 18	4
3	40090-C	M-3C FLOAT TROWEL BLADE 10 X 18 (SLIPS OVER FINISH BLADE)	4
4	4619	ADAPTER BAR 5/8" SQ. X 12"	4
5	11639	SCREW, SKT. HD. CAP 5/16-18 X 5/8	12
6	10606	SCREW, HEX HD. CAP 5/16-18 X 1-1/4	8
7	10801	WASHER, LOCK 5/16 ZINC	20

**ILLUSTRATION 10:
OPTIONAL QUICK CHANGE BLADES & ADAPTERS
FOR 30", 36", & 46" TROWELS**

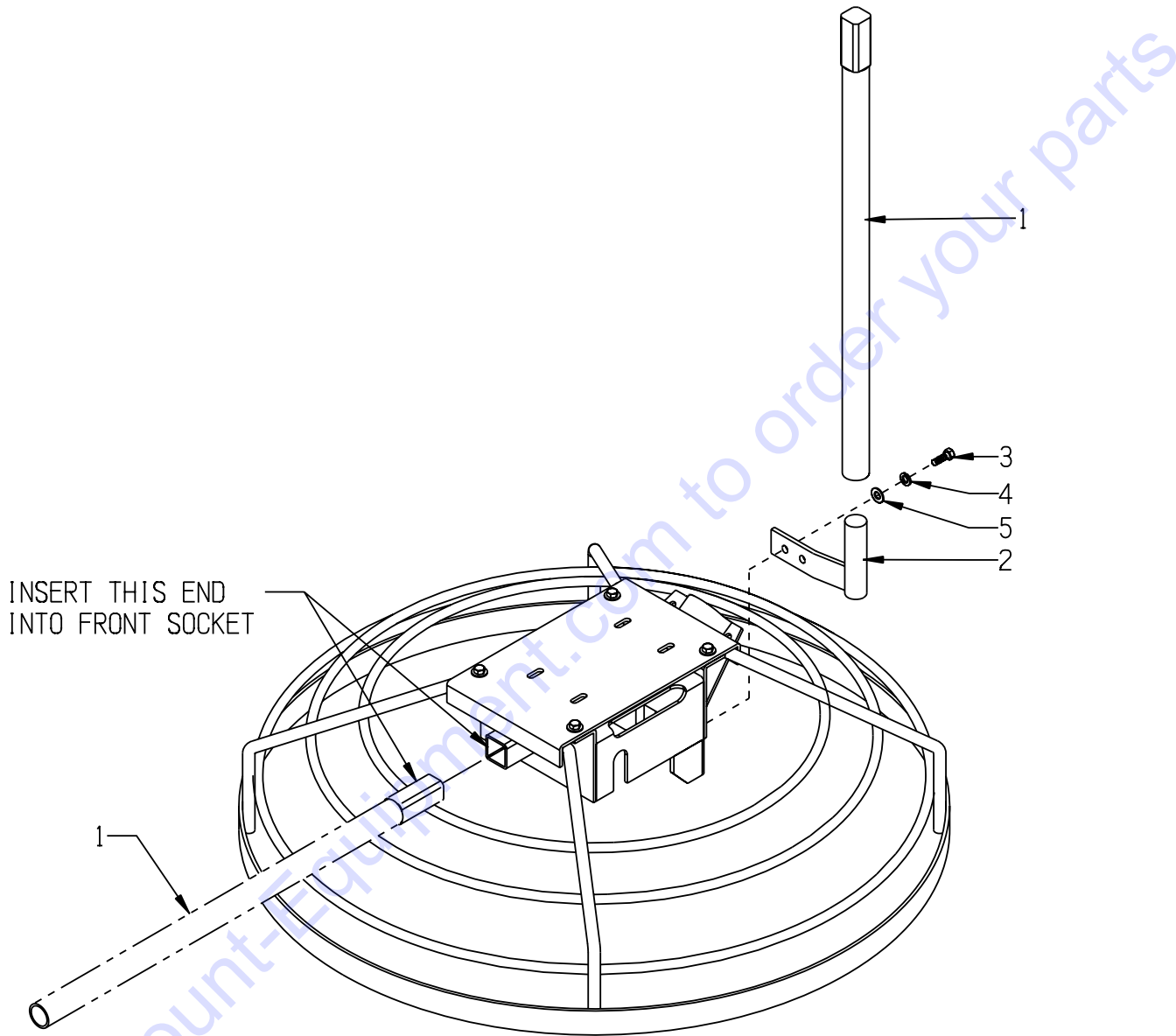


ITEM #	PART #	DESCRIPTION	QTY.
1	40270 40040 40070	COMBINATION BLADE (SHOWN) C-2, 8" x 11" C-1, 8" x 14" C-3, 8" x 18"	4
1	40290 40060 40090	FLOAT BLADE M-2, 9" x 11" M-1, 9" x 14" M-3, 9" x 18"	4
1	40280 40050 40080	FINISH BLADE F-2, 6" x 11" F-1, 6" x 14" F-3, 6" x 18"	4
2	40197 40237	ADAPTER COMPLETE (INCLUDES SPRINGS, ITEM 3) "A", 30" & 36" TROWEL, 10-1/16"L (SHOWN) "B", 46" TROWEL, 14-3/16"L	4
3	3636 4605	SPRING, EXTENSION 6"L ("A" ADAPTER) 11-1/2"L ("B" ADAPTER)	8
4	10053	SCREW, CAP 5/16-18 X 3/4	8/12
5	10213	WASHER, FLAT 5/16 SAE ZINC	8/12
6	10807	NUT, HEX LOCK 5/16-18 ZINC	8/12



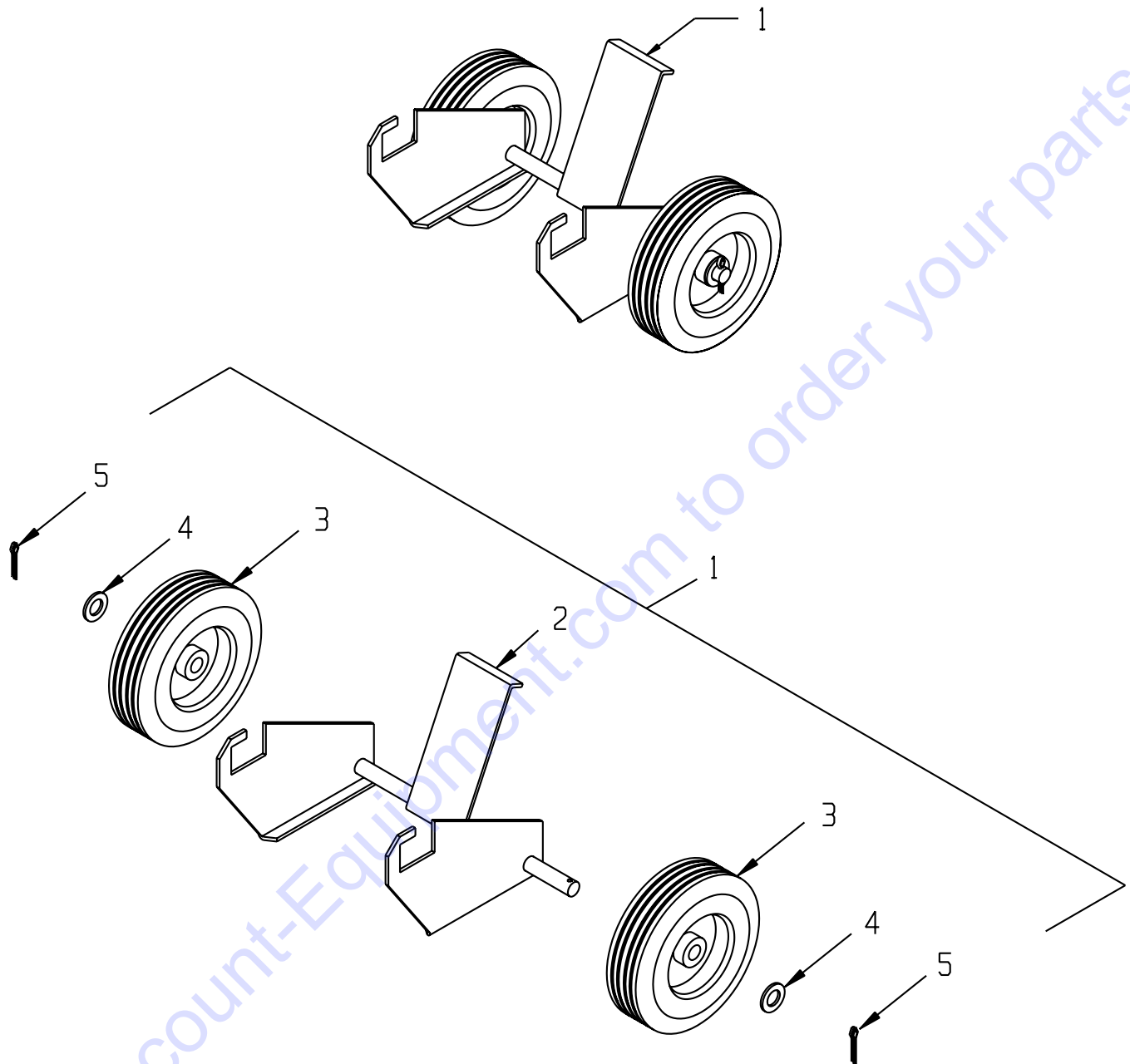
A Division of Equipment Development Company, Inc.

ILLUSTRATION 11: LIFT HANDLE GROUPING



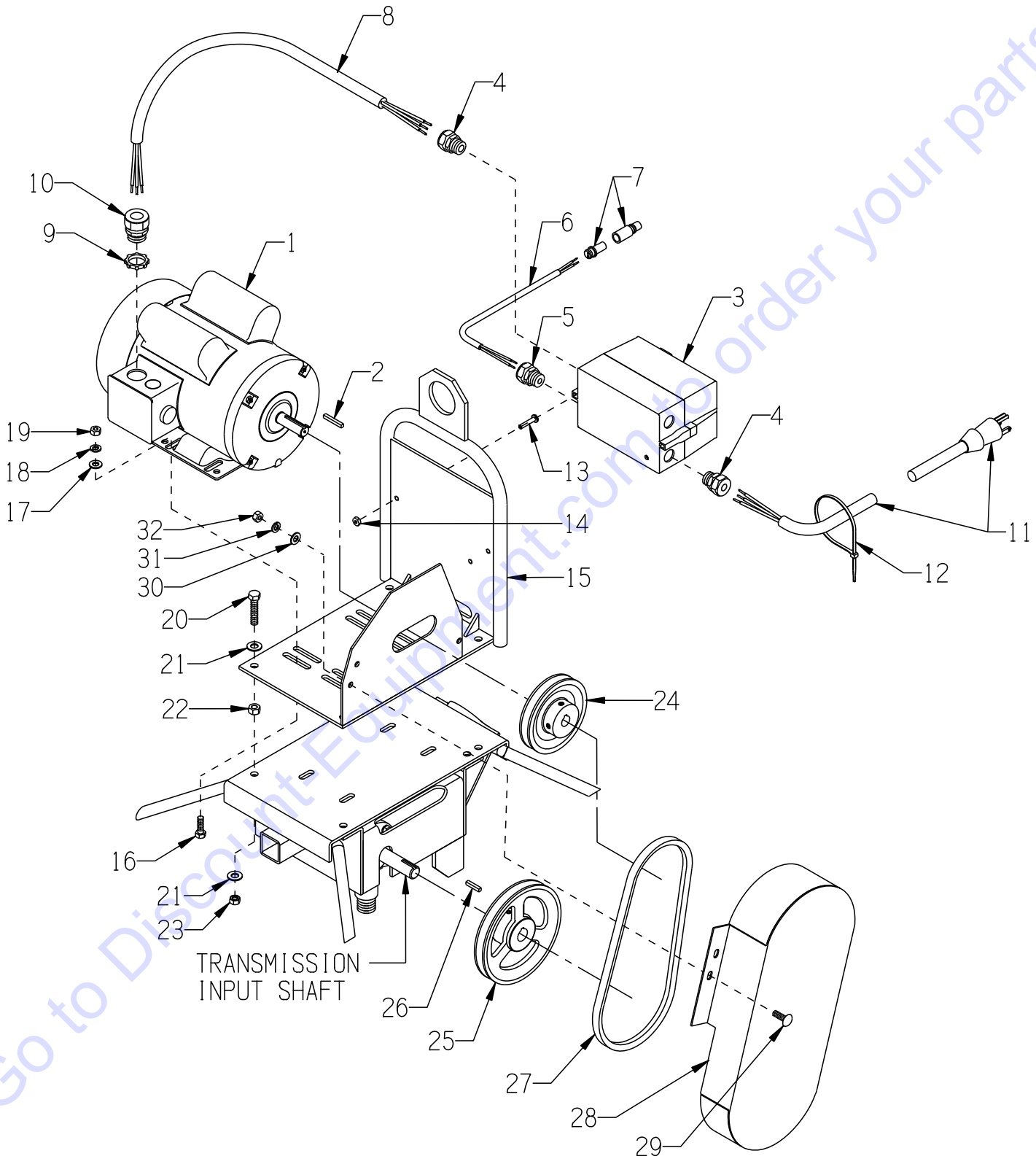
ITEM #	PART #	DESCRIPTION	QTY.
1	36091	HANDLE, LIFT	1
2	36092	HOLDER, LIFT HANDLE	1
3	10055	SCREW, CAP 3/8-16 X 1	2
4	10811	WASHER, LOCK 3/8 ZINC	2
5	10025	WASHER, FLAT 3/8 SAE ZINC	2

ILLUSTRATION 12: OPTIONAL "TOTE-A-TROWEL"



ITEM #	PART #	DESCRIPTION	QTY.
1	81400	TAT-II "TOTE-A-TROWEL" TRANSPORTER (INCLUDES ITEMS 2 THRU 5)	1
2	81401	FRAME	1
3	79013	WHEEL, 8 X 2-1/2 X 3/4" BRG. POLY HUB	2
4	10009	WASHER, FLAT 3/4 SAE ZINC	2
5	10306	PIN, COTTER 3/16 X 1-1/2	2

ILLUSTRATION 13: MOTOR GROUPING
FOR MODEL T244RS-1.5 & T304RS-1.5

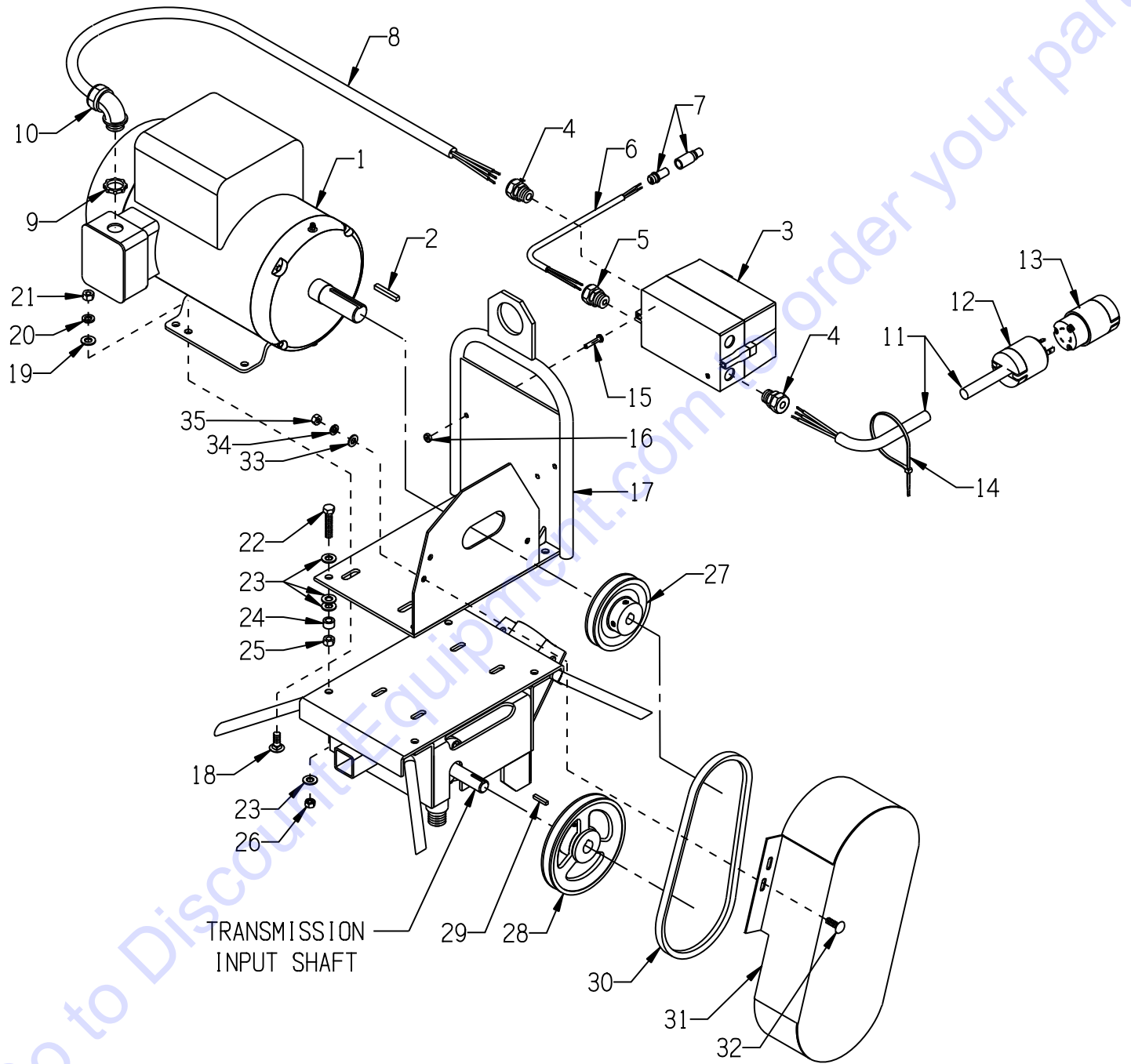


**PARTS LISTING - ILLUSTRATION 13:
MOTOR GROUPING FOR MODEL T244RS-1.5 & T304RS-1.5**

ITEM #	PART #	DESCRIPTION	QTY.
1	16077	MOTOR, LEESON 1.5HP-1P-60HZ-1725RPM	1
	16178	REPLACEMENT PARTS: CAPACITOR, START, LEESON 003025.15, 460-552 MFD, 125V	1
	16174	CAPACITOR, RUN, LEESON 003014.02, 50MFD-240V	1
	16179	RESET BUTTON, LEESON 300033.02, CED2705	1
2	----	KEY 3/16SQ. X 1-3/8 (INCLUDED W/ MOTOR)	1
3	16601	STARTER ACI #128929 RESET ONLY (SK18.310-120, 11.3-16.0A O/L)	1
	16616	REPLACEMENT PARTS: STARTER CONTACTOR W/ COIL ACI SK18.310-120	1
	16621	STARTER AC COIL 120V-60HZ	1
	16635	STARTER OVERLOAD RELAY 11.3-16.0 AMP	1
4	41130	STRAIN RELIEF 1/2NPT X .550-.650"	2
5	16190	STRAIN RELIEF 1/2NPT X .250-.350"	1
6	36138	CORD WIRE 16/2 X 15"L (STARTER TO CONNECTOR)	1
7	36131	CONNECTOR PLUG, SEALED 246-4402	1
	36132	CONNECTOR RECEPT., SEALED 246-4414	1
	36133	CONTACT, PIN 246-4424	2
	36134	CONTACT, SOCKET 246-4428	2
8	36140	CORD WIRE 12/3 X 30 "LOA (STARTER TO MOTOR)	1
9	10740	CONDUIT LOCK NUT 3/4 NP	1
10	16176	STRAIN RELIEF 3/4NPT X .350-.450"	1
11	36137	CORD W/ PLUG, 70" POWER (NEMA 5-15P 15A/125V)	1
12	10982	TIE, CABLE, BLACK NYLON 11-1/4"	4
13	11732	SCREW, MACHINE 10-32 X 1-3/4 RHP	2
	10384	SCREW, MACHINE 10-32 X 1 RHP	1
14	10832	NUT, KEPS LOCK 10-32 ZINC	3
15	36139	LIFTING BAIL/MOTOR MOUNT, TROWEL	1
16	10819	BOLT, CARRIAGE 5/16-18 X 1 FULL THD	4
17	10213	WASHER, FLAT 5/16 SAE ZINC	4
18	10801	WASHER, LOCK 5/16 ZINC	4
19	10054	NUT, HEX 5/16-18 ZINC	4
20	11729	BOLT, TAP 3/8-24 X 1-3/4(FULL THD.)	4
21	10025	WASHER, FLAT 3/8 SAE ZINC	8
22	10014	NUT, HEX 3/8-24 ZINC	4
23	10004	NUT, HEX LOCK 3/8-24 ZINC	4
24	36096	SHEAVE 4.45"OD X 1GR.A X 5/8"BORE	1
25	36013	SHEAVE 6"OD X 1GR.A X 3/4"BORE	1
26	36108	TRANS. INPUT KEY 3/16SQ X 1 (INCLUDED W/ TRANSMISSION)	1
27	10259	BELT A-29	1
28	36141	COVER, BELT, TROWEL (3" WIDTH AT TOP)	1
	36072	COVER, BELT, TROWEL (4-3/16" WIDTH AT TOP)	1
29	10819	BOLT, CARRIAGE 5/16-18 X 1 FULL THD	3
30	10213	WASHER, FLAT 5/16 SAE ZINC	3
31	10801	WASHER, LOCK 5/16 ZINC	3
32	10054	NUT, HEX 5/16-18 ZINC	3



ILLUSTRATION 14:
MOTOR GROUPING FOR MODEL T364-3

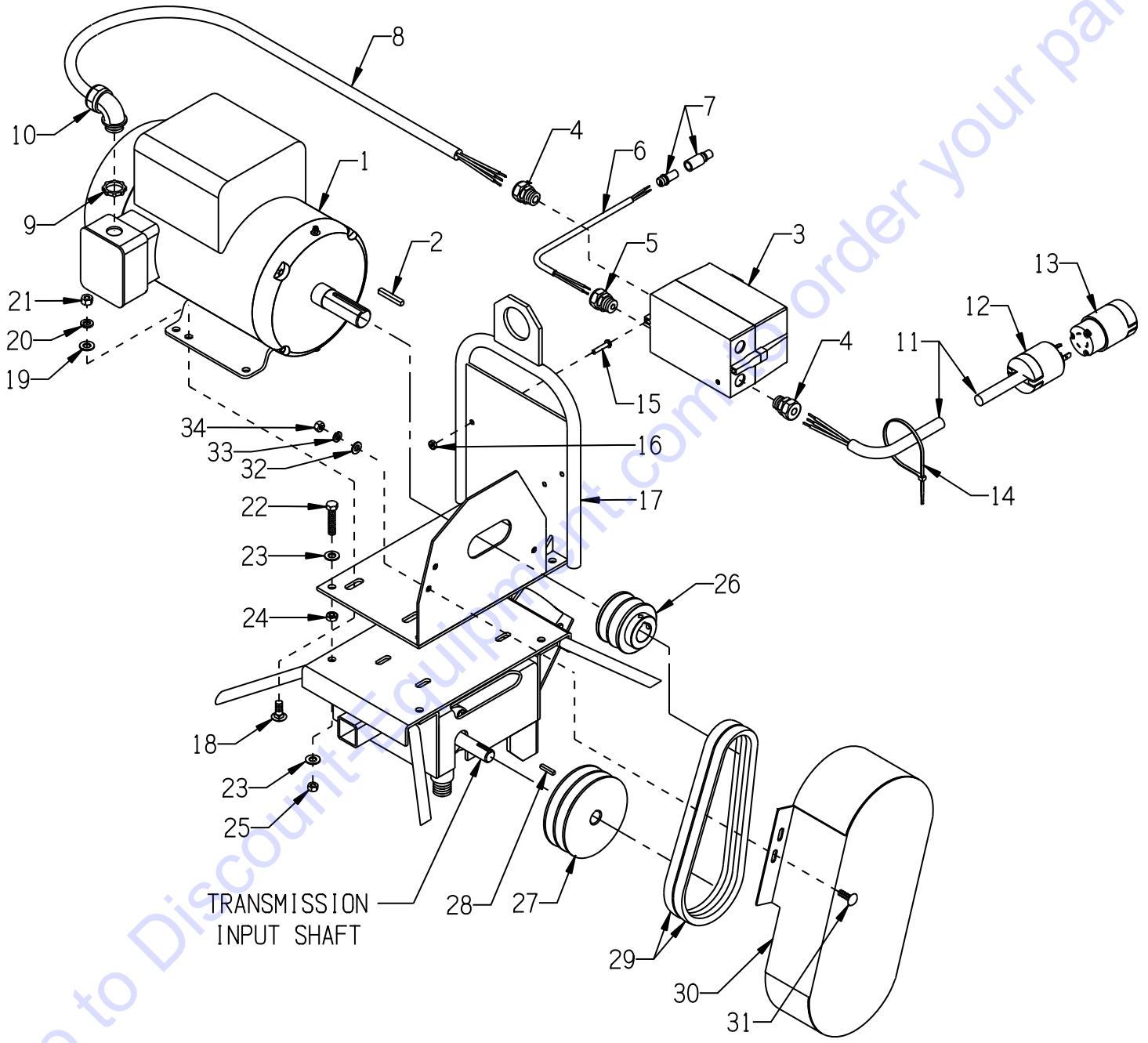


PARTS LISTING - ILLUSTRATION 14: MOTOR GROUPING FOR MODEL T364-3			
ITEM #	PART #	DESCRIPTION	QTY.
1	81014	MOTOR, BALDOR 3HP-1PH-60HZ-3450RPM	1
	77039	REPLACEMENT PART: CAPACITOR, START, BALDOR EC1850A06SP, 850MFD 115V	1
2	----	KEY 1/4SQ. X 1-3/4 (INCLUDED W/ MOTOR)	1
3	16604	STARTER ACI #128844 RESET ONLY 200/240V COIL 11.3-16.0A O/L	1
	16617	REPLACEMENT PARTS: STARTER CONTACTOR W/ COIL ACI SK18.310-230	1
	16622	STARTER AC COIL 200/240V-60HZ	1
	16635	STARTER OVERLOAD RELAY 11.3-16.0 AMP	1
4	41130	STRAIN RELIEF 1/2NPT X .550-.650"	2
5	16190	STRAIN RELIEF 1/2NPT X .250-.350"	1
6	36138	CORD WIRE 16/2 X 15"L (STARTER TO CONNECTOR)	1
7	36131	CONNECTOR PLUG, SEALED 246-4402	1
	36132	CONNECTOR RECEPT., SEALED 246-4414	1
	36133	CONTACT, PIN 246-4424	2
	36134	CONTACT, SOCKET 246-4428	2
8	36148	CORD WIRE 10/3 X 32"L (STARTER TO MOTOR)	1
9	10740	CONDUIT LOCK NUT 3/4 NP	1
10	16539	STRAIN RELIEF 90D X 3/4NPT .50-.625	1
11	36149	CORD WIRE 10/3 X 70"L, POWER	1
12	40037	PLUG, LOCKING 20A/250V L6-20P	1
13	40000	CONNECTOR, LOCKING 20A/250V L6-20C	1
14	10982	TIE, CABLE, BLACK NYLON 11-1/4"	4
15	11732	SCREW, MACHINE 10-32 X 1-3/4 RHP	2
	10384	SCREW, MACHINE 10-32 X 1 RHP	1
16	10832	NUT, KEPS LOCK 10-32 ZINC	3
17	36146	LIFTING BAIL/MOTOR MOUNT, 3&5 HP	1
18	10802	BOLT, CARRIAGE 3/8-16 X 1 ZINC	4
19	10025	WASHER, FLAT 3/8 SAE ZINC	4
20	10811	WASHER, LOCK 3/8 ZINC	4
21	10404	NUT, HEX 3/8-16 ZINC	4
22	11729	BOLT, TAP 3/8-24 X 1-3/4(FULL THD.)	4
23	10025	WASHER, FLAT 3/8 SAE ZINC	16
24	10011	SPACER, STEEL 5/8OD X 3/8ID X 3/8T	4
25	10014	NUT, HEX 3/8-24 ZINC	4
26	10004	NUT, HEX LOCK 3/8-24 ZINC	4
27	36147	SHEAVE 4"OD X 1GR.A X 1-1/8"BORE	1
28	36013	SHEAVE 6"OD X 1GR.A X 3/4"BORE	1
29	36108	TRANS. INPUT KEY 3/16SQ X 1 (INCLUDED W/ TRANSMISSION)	1
30	10249	BELT AX-31	2
31	36072	COVER, BELT, TROWEL (4-3/16" WIDTH)	1
32	10819	BOLT, CARRIAGE 5/16-18 X 1 FULL THD	3
33	10213	WASHER, FLAT 5/16 SAE ZINC	3
34	10801	WASHER, LOCK 5/16 ZINC	3
35	10054	NUT, HEX 5/16-18 ZINC	3



A Division of Equipment Development Company, Inc.

ILLUSTRATION 15:
MOTOR GROUPING FOR MODEL T464-5

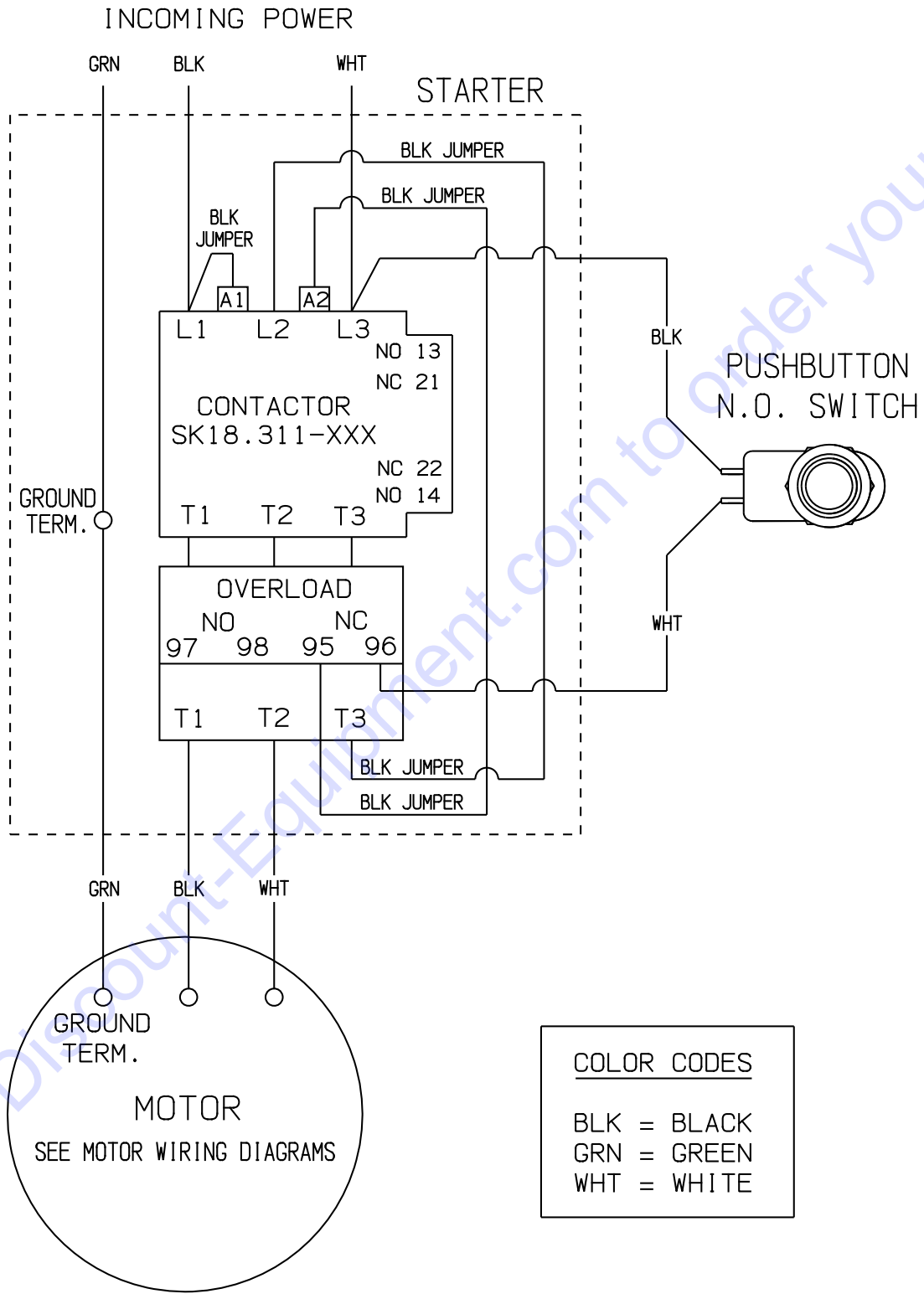


PARTS LISTING - ILLUSTRATION 15: MOTOR GROUPING FOR MODEL T464-5			
ITEM #	PART #	DESCRIPTION	QTY.
1	81026	MOTOR, BALDOR 5HP-1PH 60HZ 3450RPM REPLACEMENT PARTS:	1
	16121	CAPACITOR, START, BALDOR EC1161C06SP	2
	16164	CAPACITOR, RUN, BALDOR #OC3040F09SP	1
	16540	THERMAL PROT. (RESET BUTTON) TPBRT25DB	1
2	----	KEY 1/4SQ. X 1-3/4 (INCLUDED W/ MOTOR)	1
3	16454	STARTER ACI #128827 RESET ONLY 200/240V COIL 17.5-21.5A O/L REPLACEMENT PARTS:	1
	16617	STARTER CONTACTOR W/ COIL ACI SK18.310-230	1
	16622	STARTER AC COIL 200/240V-60HZ	1
	16637	STARTER OVERLOAD RELAY 17.5-21.5 AMP	1
4	41130	STRAIN RELIEF 1/2NPT X .550-.650"	2
5	16190	STRAIN RELIEF 1/2NPT X .250-.350"	1
6	36138	CORD WIRE 16/2 X 15"L (STARTER TO CONNECTOR)	1
7	36131	CONNECTOR PLUG, SEALED 246-4402	1
	36132	CONNECTOR RECEPT., SEALED 246-4414	1
	36133	CONTACT, PIN 246-4424	2
	36134	CONTACT, SOCKET 246-4428	2
8	36148	CORD WIRE 10/3 X 32"L (STARTER TO MOTOR)	1
9	10740	CONDUIT LOCK NUT 3/4 NP	1
10	16539	STRAIN RELIEF 90D X 3/4NPT .50-.625	1
11	36149	CORD WIRE 10/3 X 70"L, POWER	1
12	40037	PLUG, LOCKING 20A/250V L6-20P	1
13	40000	CONNECTOR, LOCKING 20A/250V L6-20C	1
14	10982	TIE, CABLE, BLACK NYLON 11-1/4"	4
15	11732	SCREW, MACHINE 10-32 X 1-3/4 RHP	2
	10384	SCREW, MACHINE 10-32 X 1 RHP	1
16	10832	NUT, KEPS LOCK 10-32 ZINC	3
17	36146	LIFTING BAIL/MOTOR MOUNT, 3&5 HP	1
18	10802	BOLT, CARRIAGE 3/8-16 X 1 ZINC	4
19	10025	WASHER, FLAT 3/8 SAE ZINC	4
20	10811	WASHER, LOCK 3/8 ZINC	4
21	10404	NUT, HEX 3/8-16 ZINC	4
22	11729	BOLT, TAP 3/8-24 X 1-3/4(FULL THD.)	4
23	10025	WASHER, FLAT 3/8 SAE ZINC	8
24	11725	NUT, HEX JAM 3/8-24 ZINC	4
25	10004	NUT, HEX LOCK 3/8-24 ZINC	4
26	79023	SHEAVE 3"OD X 2GR.B X 1-1/8"BORE	1
27	77058	SHEAVE 5"OD X 2GR.B X 3/4"BORE	1
28	36108	TRANS. INPUT KEY 3/16SQ X 1 (INCLUDED W/ TRANSMISSION)	1
29	10234	BELT 5L-290 (21/32" X 29")	2
30	36072	COVER, BELT, TROWEL (4-3/16" WIDTH)	1
31	10819	BOLT, CARRIAGE 5/16-18 X 1 FULL THD	3
32	10213	WASHER, FLAT 5/16 SAE ZINC	3
33	10801	WASHER, LOCK 5/16 ZINC	3
34	10054	NUT, HEX 5/16-18 ZINC	3



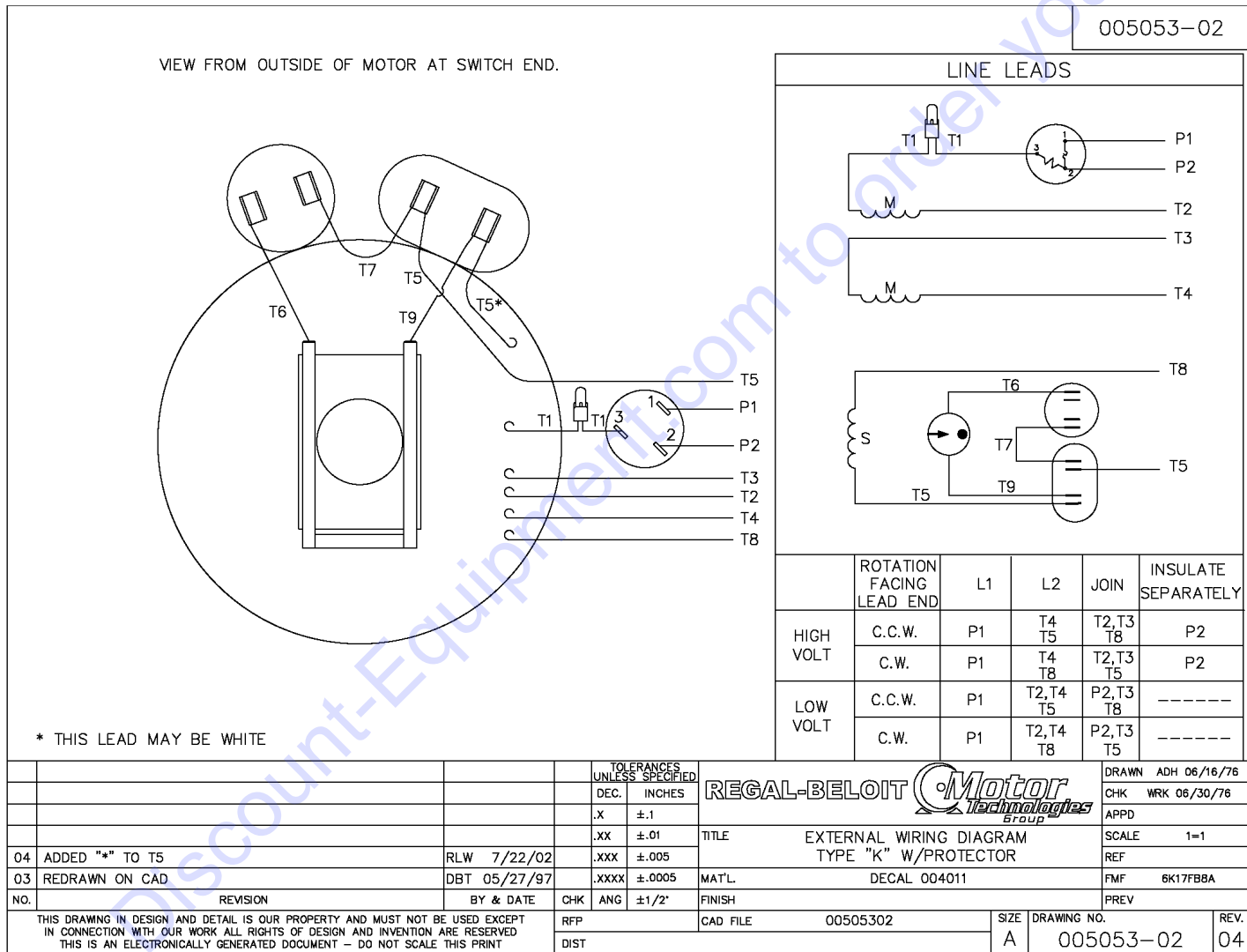
A Division of Equipment Development Company, Inc.

WIRING DIAGRAM FOR STARTER & SWITCH



WIRING DIAGRAM FOR LEESON 1.5 HP MOTOR

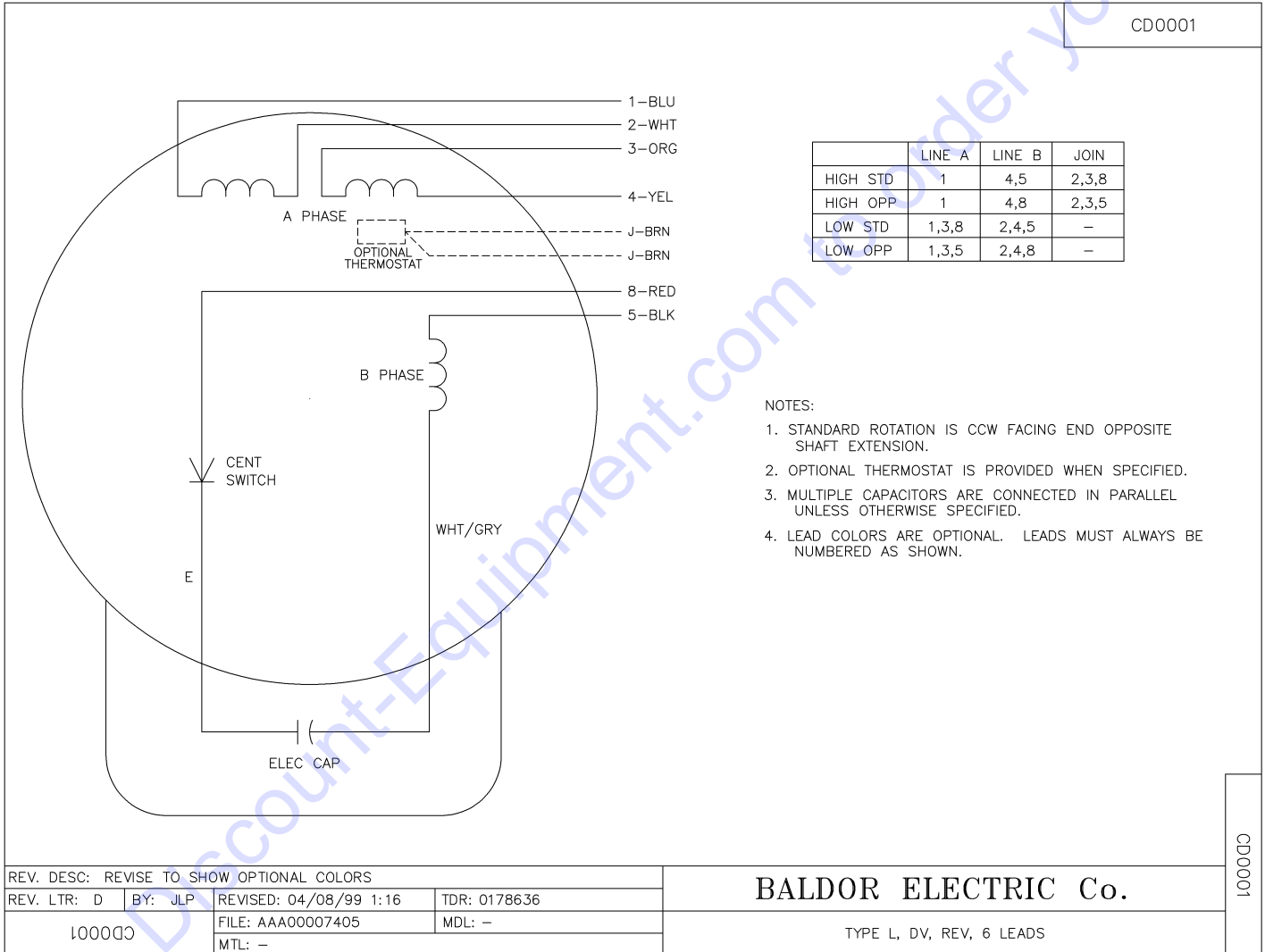
LEESON CAT. NO. 113769.00
 1.5 H.P., 1 PHASE, 60 HERTZ, 1725 RPM,
 115 VOLT, 13.0 FULL LOAD AMPS



WIRING DIAGRAM FOR BALDOR 3 HP MOTOR

BALDOR CAT. NO. L3606T
 3 H.P., 1 PHASE, 60 HERTZ, 3450 RPM,
 230 VOLT, 14.5 FULL LOAD AMPS

CD0001



CD0001

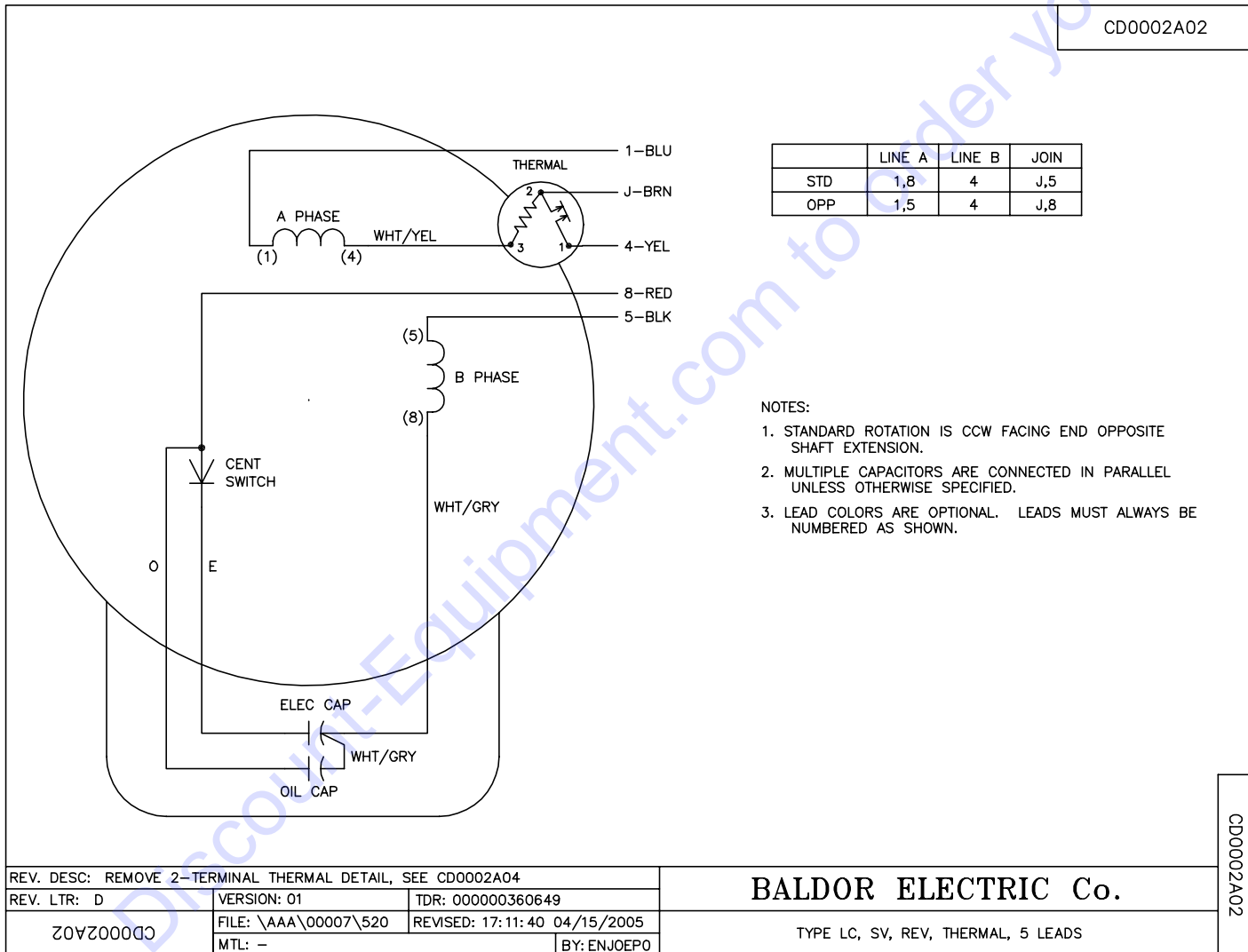
REV. DESC: REVISE TO SHOW OPTIONAL COLORS			
REV. LTR: D	BY: JLP	REVISED: 04/08/99 1:16	TDR: 0178636
100000		FILE: AAA00007405	MDL: -
		MTL: -	

BALDOR ELECTRIC Co.

TYPE L, DV, REV, 6 LEADS

WIRING DIAGRAM FOR BALDOR 5 HP MOTOR

BALDOR CAT. NO. L3608TM
 5 H.P., 1 PHASE, 60 HERTZ, 3450 RPM,
 230 VOLT, 19.5 FULL LOAD AMPS



PARTS FINDER

**Search Website
by Part Number**



**Search Manual
Library For Parts
Manual & Lookup Part
Numbers – Purchase
or Request Quote**

Search Manuals

Enter your information to help us find the right parts manual for your machine.

* Brand:

* Model:

* Serial:

* Part Number:

SEARCH

**Can't Find Part or
Manual? Request Help
by Manufacturer,
Model & Description**

Parts Order Form

Please fill in the following information to help us find the right part for your machine.

Manufacturer:	<input type="text"/>
Model:	<input type="text"/>
Description:	<input type="text"/>
Part Number:	<input type="text"/>
Quantity:	<input type="text"/>
Notes:	<input type="text"/>

SEARCH

Discount-Equipment.com is your online resource for quality parts & equipment.

Florida: **561-964-4949** Outside Florida TOLL FREE: **877-690-3101**

Need parts?

Click on this link: <http://www.discount-equipment.com/category/5443-parts/> and choose one of the options to help get the right parts and equipment you are looking for. Please have the machine model and serial number available in order to help us get you the correct parts. If you don't find the part on the website or on one of the online manuals, please fill out the request form and one of our experienced staff members will get back to you with a quote for the right part that your machine needs.

We sell worldwide for the brands: Genie, Terex, JLG, MultiQuip, Mikasa, Essick, Whiteman, Mayco, Toro Stone, Diamond Products, Generac Magnum, Airman, Haulotte, Barreto, Power Blanket, Nifty Lift, Atlas Copco, Chicago Pneumatic, Allmand, Miller Curber, Skyjack, Lull, Skytrak, Tsurumi, Husquvarna Target, Stow, Wacker, Sakai, Mi-T-M, Sullair, Basic, Dynapac, MBW, Weber, Bartell, Bennar Newman, Haulotte, Ditch Runner, Menegotti, Morrison, Contec, Buddy, Crown, Edco, Wyco, Bomag, Laymor, EZ Trench, Bil-Jax, F.S. Curtis, Gehl Pavers, Heli, Honda, ICS/PowerGrit, IHI, Partner, Imer, Clipper, MMD, Koshin, Rice, CH&E, General Equipment, Amida, Coleman, NAC, Gradall, Square Shooter, Kent, Stanley, Tamco, Toku, Hatz, Kohler, Robin, Wisconsin, Northrock, Oztec, Toker TK, Rol-Air, APT, Wylie, Ingersoll Rand / Doosan, Innovatech, Con X, Ammann, Mecalac, Makinex, Smith Surface Prep, Small Line, Wanco, Yanmar