

# OPERATION MANUAL



[www.Discount-Equipment.com](http://www.Discount-Equipment.com)

## **GLOBUG MODEL GBX4S LIGHT CART**

Revision #0 (12/09/19)



**THIS MANUAL MUST ACCOMPANY THE EQUIPMENT AT ALL TIMES.**

**TO PURCHASE THIS PRODUCT PLEASE CONTACT US**



**Equipment Financing and  
Extended Warranties Available**



**Discount-Equipment.com is your online resource for  
commercial and industrial quality parts and equipment sales.**

**561-964-4949**

**visit us on line @ [www.discount-equipment.com](http://www.discount-equipment.com)**

Select an option below to find your Equipment

**Search by Manufacturer**

**Search by Product Type**

**Request a Quote**

We sell worldwide for the brands: Genie, Terex, JLG, MultiQuip, Mikasa, Essick, Whiteman, Mayco, Toro Stone, Diamond Products, Generac Magnum, Airman, Haulotte, Barreto, Power Blanket, Nifty Lift, Atlas Copco, Chicago Pneumatic, Allmand, Miller Curber, Skyjack, Lull, Skytrak, Tsurumi, Husquvarna Target, Stow, Wacker, Sakai, Mi-T-M, Sullair, Basic, Dynapac, MBW, Weber, Bartell, Bennar Newman, Haulotte, Ditch Runner, Menegotti, Morrison, Contec, Buddy, Crown, Edco, Wyco, Bomag, Laymor, EZ Trench, Bil-Jax, F.S. Curtis, Gehl Pavers, Heli, Honda, ICS/PowerGrit, IHI, Partner, Imer, Clipper, MMD, Koshin, Rice, CH&E, General Equipment, Amida, Coleman, NAC, Gradall, Square Shooter, Kent, Stanley, Tamco, Toku, Hatz, Kohler, Robin, Wisconsin, Northrock, Oztec, Toker TK, Rol-Air, APT, Wylie, Ingersoll Rand / Doosan, Innovatech, Con X, Ammann, Mecalac, Makinex, Smith Surface Prep, Small Line, Wanco, Yanmar

**PROPOSITION 65 WARNING**

---



To order go to [Discount-Equipment.com](http://Discount-Equipment.com)

**GBX4S Light Cart**

Proposition 65 Warning ..... 2  
Safety Information ..... 5-12  
Specifications ..... 13-14  
Dimensions..... 15  
Footcandle Plot..... 16  
General Information..... 17  
Control Panel..... 18-19  
Components ..... 20-21  
Generator Components ..... 22-23  
Setup ..... 24-26  
Operation..... 27-30  
Storage..... 31  
Transporting..... 32  
Maintenance ..... 33-39  
Troubleshooting ..... 40-43  
Wiring Diagram..... 44

**NOTICE**

Specifications are subject to change without notice.

To order go to [Discount-Equipment.com](http://Discount-Equipment.com)



# SAFETY INFORMATION

Do not operate or service the equipment before reading the entire manual. Safety precautions should be followed at all times when operating this equipment. Failure to read and understand the safety messages and operating instructions could result in injury to yourself and others.

## SAFETY MESSAGES







The four safety messages shown below will inform you about potential hazards that could injure you or others. The safety messages specifically address the level of exposure to the operator and are preceded by one of four words: **DANGER**, **WARNING**, **CAUTION** or **NOTICE**.

### SAFETY SYMBOLS

 <b>DANGER</b>
<p>Indicates a hazardous situation which, if not avoided, <b>WILL</b> result in <b>DEATH</b> or <b>SERIOUS INJURY</b>.</p>
 <b>WARNING</b>
<p>Indicates a hazardous situation which, if not avoided, <b>COULD</b> result in <b>DEATH</b> or <b>SERIOUS INJURY</b>.</p>
 <b>CAUTION</b>
<p>Indicates a hazardous situation which, if not avoided, <b>COULD</b> result in <b>MINOR</b> or <b>MODERATE INJURY</b>.</p>
<b>NOTICE</b>
<p>Addresses practices not related to personal injury.</p>

### SAFETY SYMBOLS

Potential hazards associated with the operation of this equipment will be referenced with hazard symbols which may appear throughout this manual in conjunction with safety messages.

Symbol	Safety Hazard
	Lethal exhaust gas hazards
	Explosive fuel hazards
	Burn hazards
	Overspeed hazards
	Rotating parts hazards
	Pressurized fluid hazards
	Electric shock hazards

# SAFETY INFORMATION

## GENERAL SAFETY

### CAUTION

- **NEVER** operate this equipment without proper protective clothing, shatterproof glasses, respiratory protection, hearing protection, steel-toed boots and other protective devices required by the job or city and state regulations.



- **NEVER** operate this equipment when not feeling well due to fatigue, illness or when under medication.



- **NEVER** operate this equipment under the influence of drugs or alcohol.



- **ALWAYS** check the equipment for loosened threads or bolts before starting.

- **DO NOT** use the equipment for any purpose other than its intended purposes or applications.

### NOTICE

- This equipment should only be operated by trained and qualified personnel 18 years of age and older.
- Whenever necessary, replace nameplate, operation and safety decals when they become difficult read.
- Manufacturer does not assume responsibility for any accident due to equipment modifications. Unauthorized equipment modification will void all warranties.
- **NEVER** use accessories or attachments that are not recommended by Multiquip for this equipment. Damage to the equipment and/or injury to user may result.

- **ALWAYS** know the location of the nearest fire extinguisher.



- **ALWAYS** know the location of the nearest first aid kit.

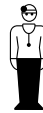

- **ALWAYS** know the location of the nearest phone or keep a phone on the job site. Also, know the phone numbers of the nearest ambulance, doctor and fire department. This information will be invaluable in the case of an emergency.

# SAFETY INFORMATION

## LIGHT CART SAFETY

### DANGER

- **NEVER** operate the equipment in an explosive atmosphere or near combustible materials. An explosion or fire could result causing severe **bodily harm or even death.**



### WARNING

- **NEVER** disconnect any **emergency or safety devices.** These devices are intended for operator safety. Disconnection of these devices can cause severe injury, bodily harm or even death. Disconnection of any of these devices will void all warranties.

### CAUTION

- **NEVER** lubricate components or attempt service on a running machine.
- **ALWAYS** ensure light cart is on level ground before use so that it cannot slide or shift around, endangering workers. Always keep immediate area free of bystanders.
- **ALWAYS** make sure brake is on before raising mast. Use blocks on wheels for extra support.
- **ALWAYS** keep area behind cart clear of people while raising and lowering mast.
- **CHECK** the mast for wear. If any problem occurs when lowering or raising the tower, **STOP** immediately! Contact a trained technician for assistance.
- **NEVER** extend or retract mast while unit is operating.
- **ALWAYS** lower the mast when not in use, or if high winds or electrical storms are expected.

### NOTICE

- **ALWAYS** keep the immediate area surrounding the light cart clean, neat, and free of debris.
- **ALWAYS** keep the machine in proper running condition.
- Fix damage to machine and replace any broken parts immediately.

### NOTICE

- **ALWAYS** store equipment properly when it is not being used. Equipment should be stored in a clean, dry location out of the reach of children and unauthorized personnel.
- To prevent the light cart from overturning, adjust mast to the lowest height in winds that exceed **45 MPH (72 KPH).**
- **DO NOT** use light cart in high wind conditions.

## LAMP SAFETY

### WARNING

- **NEVER** attempt to replace lamp with the power on. Always shut down the engine when changing the lamp.

### CAUTION

- **NEVER** use force when installing the lamp. Excessive force could cause the lamp to break, causing bodily harm.

### NOTICE

- **NEVER** leave any grease or oil residue on lamp surface when replacing or removing lamp. This can create hot spots, reducing the service life of the lamp.
- **ALWAYS** make sure lamp surface is clean and dry.
- **ALWAYS** replace with MQ recommended type lamp.
- **ALWAYS** have a **trained technician** install and remove a lamp, or replace any damaged fixture wiring.

# SAFETY INFORMATION

## ENGINE SAFETY

### DANGER

- The engine fuel exhaust gases contain poisonous carbon monoxide. This gas is colorless and odorless, and can cause death if inhaled.
- The engine of this equipment requires an adequate free flow of cooling air. **NEVER** operate this equipment in any enclosed or narrow area where free flow of the air is restricted. If the air flow is restricted it will cause injury to people and property and serious damage to the equipment or engine.



### WARNING

- **DO NOT** place hands or fingers inside engine compartment when engine is running.
- **NEVER** operate the engine with heat shields or guards removed.
- Keep fingers, hands hair and clothing away from all moving parts to prevent injury.
- **DO NOT** remove the radiator cap while the engine is hot. High pressure boiling water will gush out of the radiator and severely scald any persons in the general area of the generator.
- **DO NOT** remove the engine oil drain plug while the engine is hot. Hot oil will gush out of the oil tank and severely scald any persons in the general area of the generator.



### CAUTION

- **NEVER** touch the hot exhaust manifold, muffler or cylinder. Allow these parts to cool before servicing equipment.



## NOTICE

- **NEVER** run engine without an air filter or with a dirty air filter. Severe engine damage may occur. Service air filter frequently to prevent engine malfunction.
- **NEVER** tamper with the factory settings of the engine or engine governor. Damage to the engine or equipment can result if operating in speed ranges above the maximum allowable.
- **NEVER** tip the engine to extreme angles during lifting as it may cause oil to gravitate into the cylinder head, making the engine start difficult.
- State Health Safety Codes and Public Resources Codes specify that in certain locations, spark arresters must be used on internal combustion engines that use hydrocarbon fuels. A spark arrester is a device designed to prevent accidental discharge of sparks or flames from the engine exhaust. Spark arresters are qualified and rated by the United States Forest Service for this purpose. In order to comply with local laws regarding spark arresters, consult the engine distributor or the local Health and Safety Administrator.





# SAFETY INFORMATION

## FUEL SAFETY

### DANGER

- **DO NOT** start the engine near spilled fuel or combustible fluids. Gasoline is extremely flammable and its vapors can cause an explosion if ignited.
- **ALWAYS** refuel in a well-ventilated area, away from sparks and open flames.
- **ALWAYS** use extreme caution when working with **flammable** liquids.
- **DO NOT** fill the fuel tank while the engine is running or hot.
- **DO NOT** overfill tank, since spilled fuel could ignite if it comes into contact with hot engine parts or sparks from the ignition system.
- Store fuel in appropriate containers, in well-ventilated areas and away from sparks and flames.
- **NEVER** use fuel as a cleaning agent.
- **DO NOT** smoke around or near the equipment. Fire or explosion could result from fuel vapors or if fuel is spilled on a hot engine.



## TRANSPORTING SAFETY

### CAUTION

- Before lifting, make sure that light cart parts are not damaged and screws are not loosened or lost.
- **ALWAYS** make sure lifting device has been properly secured to lifting hook of the equipment.
- **NEVER** lift the equipment while engine is running.
- Use adequate lifting cable (wire or rope) of sufficient strength.
- Use suspension hooks and lift straight upwards.

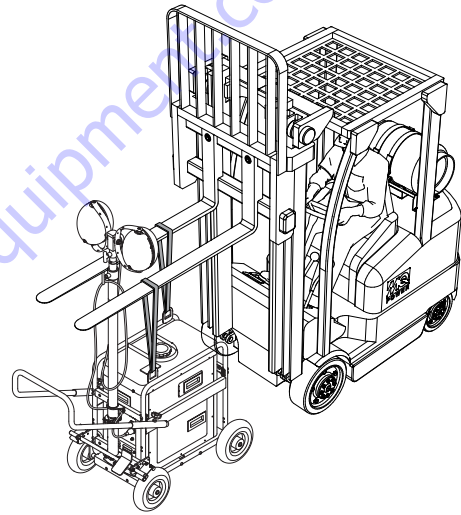

- Use mechanical cart brake to prevent rolling when transporting and while parked for operations.
- **NEVER** allow any person or animal to stand underneath the equipment while lifting.
- **DO NOT** lift equipment to unnecessary heights.

# SAFETY INFORMATION

## ELECTRICAL SAFETY

### DANGER

■ The electrical voltage required to operate the generator can cause severe injury or even death through physical contact with live circuits. Turn generator **OFF** before performing maintenance on the generator.

■ **NEVER** insert any objects into the output receptacles during operation. This is extremely dangerous. The possibility exists of **electrical shock, electrocution or death.**



■ **NEVER** operate light cart or handle any electrical equipment while standing in water, while barefoot, while hands are wet or in the rain. A dangerous **electrical shock** could occur, causing **severe bodily harm or even death.**

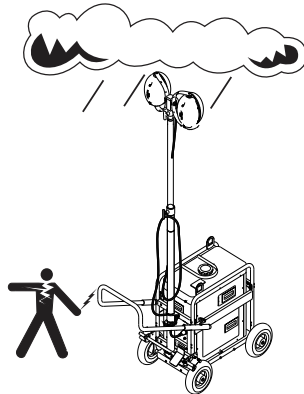

■ **ALWAYS** make sure the area above the light cart is open and clear of overhead power lines and other obstructions. The tower extends in excess of 11 feet (3.5 meters). Contact with overhead power lines or other obstructions could result in equipment damage, **electrical shock, electrocution and even death.**

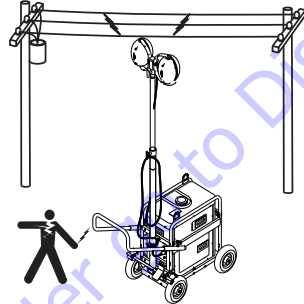

■ Similar to boom equipment, light cart may become energized with high voltage. **DO NOT** operate the light cart within a radial distance of 17 feet (5.1 meters) from high voltage power lines. If light cart becomes energized with high voltage, contact with the equipment could result in electrocution.

■ **NEVER** operate the light cart in winds in excess of 45 MPH (72 KPH).

■ Backfeed to a utility system can cause **electrocution** and/or property damage. **NEVER** connect the generator to a building's electrical system without a transfer switch

or other approved device. All installations should be performed by a **licensed electrician** in accordance with all applicable laws and electrical codes. Failure to do so could result in electrical shock or burn, causing **serious injury or even death.**



## Power Cord/Cable Safety

### DANGER

■ **NEVER** let power cords or cables lay in water.

■ **NEVER** use **damaged** or **worn** cables or cords when connecting equipment to generator. Inspect for cuts in the insulation.

■ **NEVER** grab or touch a live power cord or cable with wet hands. The possibility exists of **electrical shock, electrocution or death.**

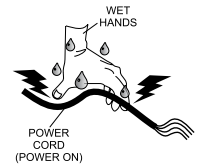

■ Make sure power cables are securely connected. Incorrect connections may cause electrical shock and damage to the light cart.

## Grounding Safety

### DANGER

■ The light cart is equipped with a ground terminal for your protection. **ALWAYS** complete the grounding path from the light cart to an external grounding source.

■ **ALWAYS** make sure that electrical circuits are properly grounded to a suitable earth ground (ground rod) per the National Electrical Code (NEC) and local codes before operating generator. **Severe injury or death by electrocution** can result from operating an ungrounded generator.

■ **NEVER** use gas piping as an electrical ground.

## ENVIRONMENTAL SAFETY

### NOTICE

■ Dispose of hazardous waste properly. Examples of potentially hazardous waste are used motor oil, fuel and fuel filters.



■ **DO NOT** use food or plastic containers to dispose of hazardous waste.

■ **DO NOT** pour waste, oil or fuel directly onto the ground, down a drain or into any water source.

# SPECIFICATIONS

Table 1. GBX4S Light Cart Specifications		
Model		GBX4S
Light Cart	Voltage	120 VAC
	Frequency	50/60 Hz
	Max. Current	3.4 A
	Wind Stability	45 mph (20 m/s)
Light	Type	LED 200 W (X2)
	Dimming Control	3 stages: 200W - 100W - 35W
	Lumens	56,000 lm (400W)
		28,000 lm (200W)
		9,800 lm (70W)
Ambient Temperature	14 to 104°F (-10 to 40°C)	
Mast	Format	Telescopic System Up to 3rd Stage (with air brake)
	Operation Method	Manual
Cart	Tire	8.7 in. Dia. (220 mm) x 4 Air Tire
	Tire Inflation Pressure	36 psi (250 kPa)
	Brake	Stepping Brake
Overall Dimensions (L x W x H)	Stowed	32.4 x 21.6 x 64.3 inch (825 x 550 x 1635 mm)
	Working	47.0 x 21.6 x 128.3 inch (1195 x 550 x 3260 mm)
Weight	Lamp Fixture	15.9 lb (7.2 kg)
	Mast	5.9 lb (2.7 kg)
	Cart	63.1 lb (28.6 kg)
	Generator	79.6 lb (36.1 kg)
	Total	164.5 lb (74.6 kg)

## SPECIFICATIONS

Model	LBG1600i
Type	Multipolar, field rotating type
Power Factor	1
Rated Frequency	60 Hz
Rated Output	1.6 kVA
Rated Voltage	120 V
Rated Current	13.3 A
AC Overcurrent Protection Equipment	Electronic type
Engine Type	Air-cooled 4-stroke gasoline engine
Engine Total Displacement	79.7 cc
Engine Fuel Type	Unleaded regular gasoline
Engine Spark Plug	A5RTC (Torch) CR5HSB (NGK)
Engine Oil Type	SAE 10W-30
Engine Oil Capacity	0.1 gal (0.38 L)
Fuel Capacity	3 gal (11 L)
Rated Continuous Operating Time	12 hours
Starting Method	Recoil Type
Operating Temperature	23 to 104°F (-5 to 40°C)
Dry Weight	79.6 lb (36.1 kg)

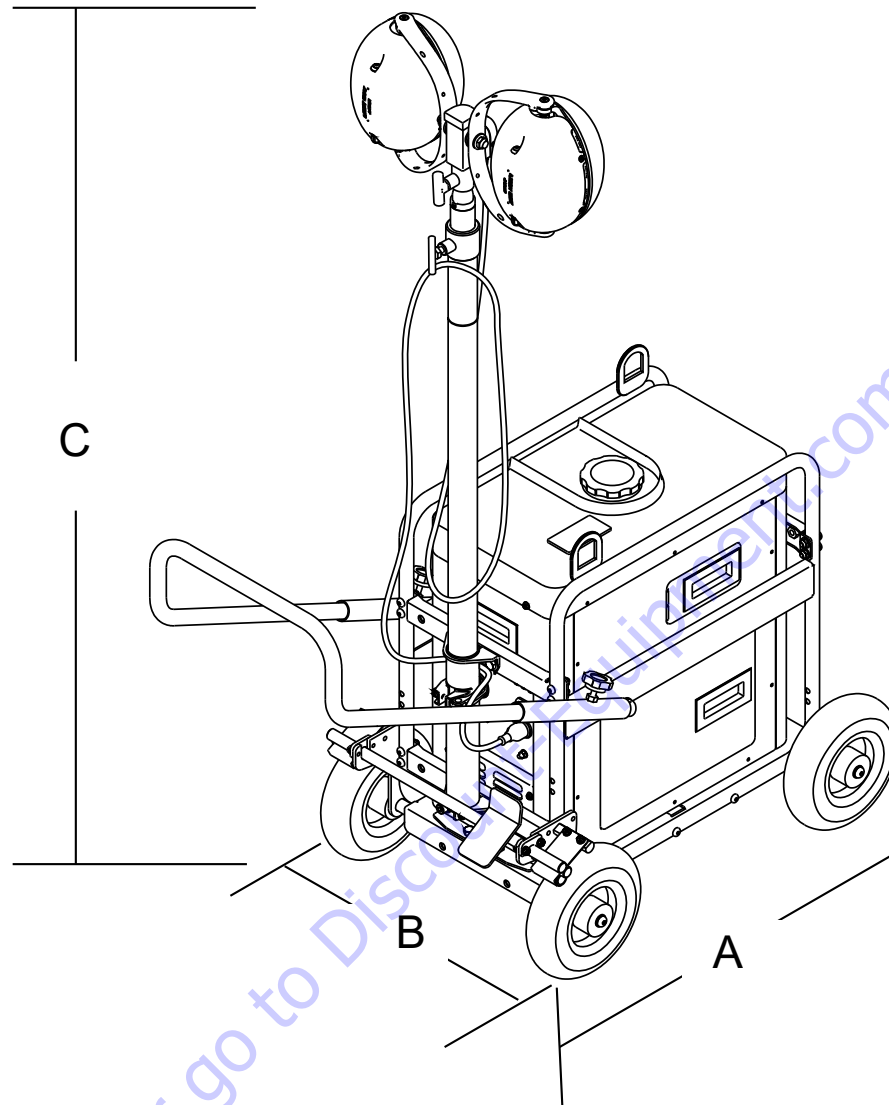
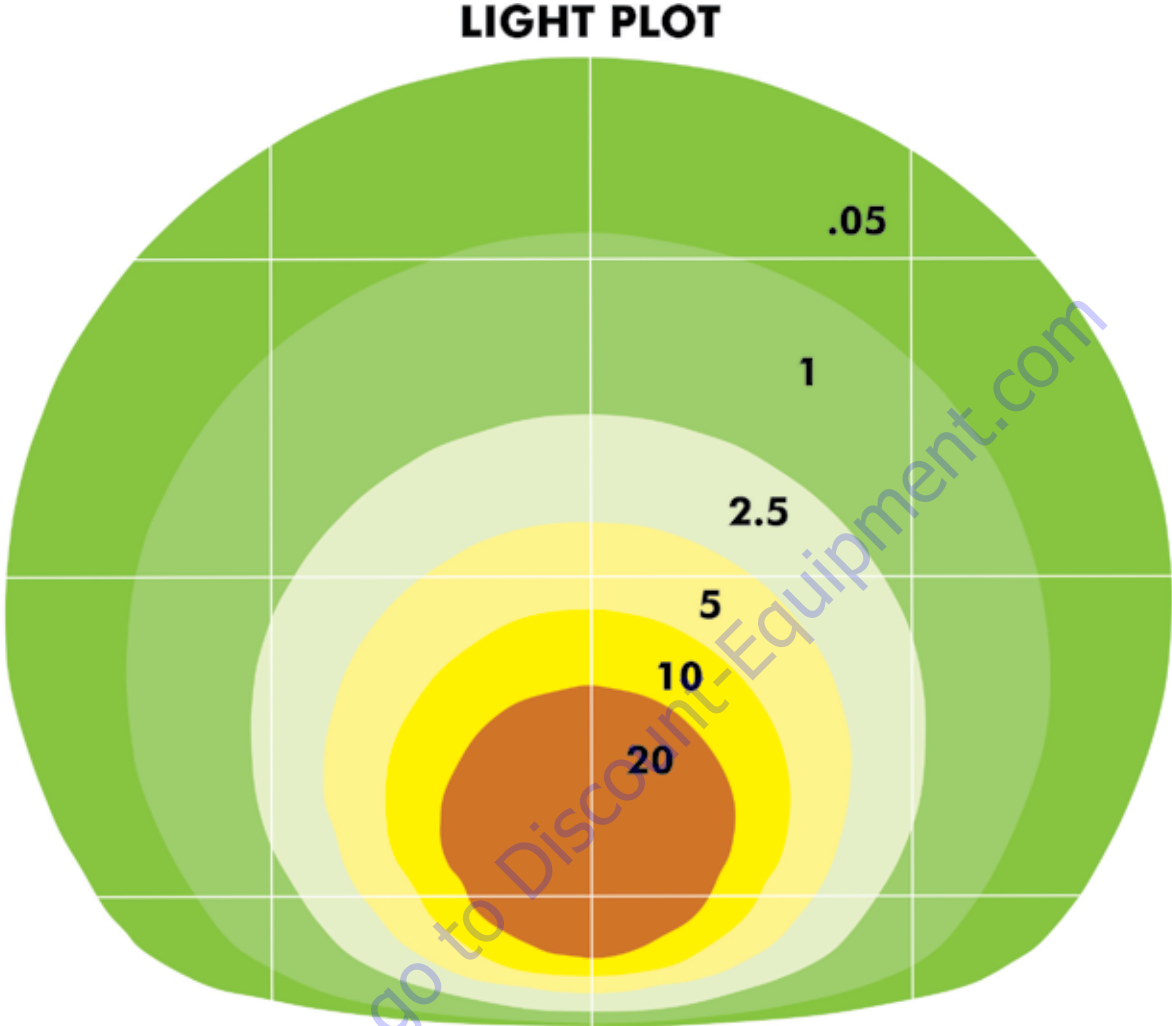

Figure 1. GBX4S Dimensions

Table 3. GBX4S Dimensions	
Reference Letter	Dimension in. (mm)
A	32.4 (825)
B	21.6 (550)
C	64.3 ~ 128.3 (1635 ~ 3260)



**Grid = 25'**

<b>Footcandle</b>	<b>20</b>	<b>10</b>	<b>5</b>	<b>2.5</b>	<b>1</b>	<b>0.5</b>
<b>Distance (Ft)</b>	<b>20</b>	<b>29</b>	<b>37</b>	<b>46</b>	<b>61</b>	<b>75</b>

Figure 2. Footcandle Plot

## GENERAL INFORMATION

---

The Multiquip model GBX4S is a compact, mobile light cart that provides exceptional clear lighting for multiple applications found in: construction, emergency response, special events, security, and general large projection lighting challenges.

The GBX4S utilizes 2 powerful 200W LED lamps that are supported by industrial grade enclosures that withstand high impact and inclement weather. The LED assembly at full power, projects 56,000 lumens. The two lamps are adjustable to infinite angles and direction for optimum lighting orientation.

The GBX4S is a self-contained, compact mobile lighting solution that is powered by an on-board, 3.5HP EPA/CARB certified, gasoline engine Gen/Set system that delivers 1.6 kVA of power with a run time of 12 hours at full load.

This LED lighting unit is supported by an industrial grade, mobile, 4-wheel cart with a 3-stage, air-assisted mast assembly, mechanical foot brake, and adjustable handle.

Unit sets up in minutes to provide crisp, powerful lighting. At full extension, the mast assembly rises to 10.7 feet.

To order go to [Discount-Equipment.com](http://Discount-Equipment.com)

# CONTROL PANEL

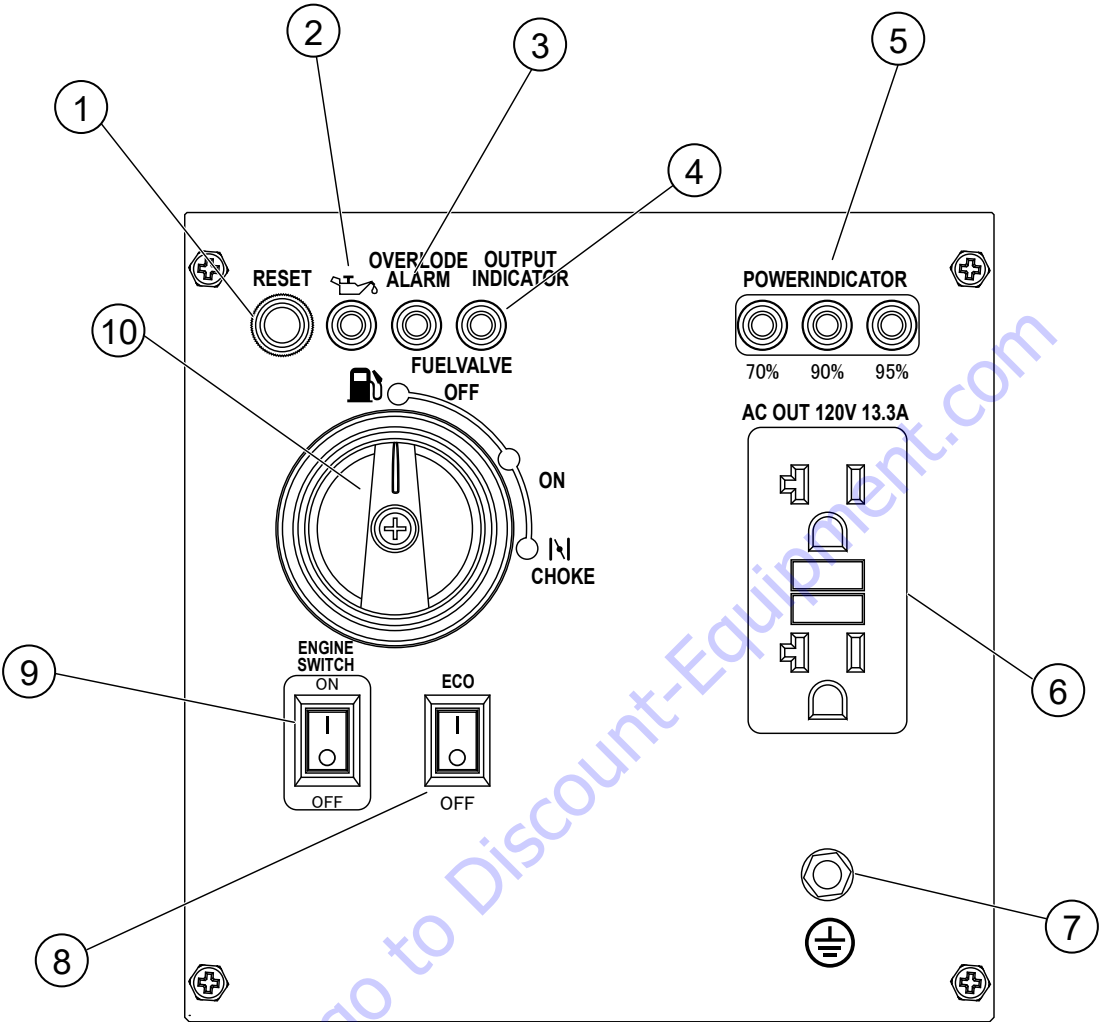

Figure 3. GBX4S Control Panel



## CONTROL PANEL

---

- Output Reset Button (for AC)** — If the Overload Warning Lamp lights red and the Output Lamp is off, press this button to reset. The Output Lamp will light green and supply of power is restarted.  
  
Before pressing this button, be sure to do the following:
  - Disconnect all electrical devices from this generator.
  - Make sure that excessive power is not used and all electrical devices are within the rated power.
  - Check wiring connections for any miswiring.
  - Check the generator temperature and make sure it is not abnormally high.
  - Check the cooling air intake port of the generator and make sure it is not blocked and that the maintenance covers are securely attached.
- Oil Warning Lamp** — Lights red to indicate that engine oil is insufficient. Engine stops. Inspect engine oil level and replenish as necessary.
- Overload Warning Lamp** — Lights or flashes red if an error described in the following table, “Lamp Indications” occurs during power generation. After engine startup however, this lamp goes on for a few seconds even if no error occurs.
- Output Lamp** — Lights green to indicate power generation.
- Power Indicator** — Indicates power use status. If only one lamp is ON, power is at 70% , two lamps ON, power is at 90%, and three lamps ON, power is at 95%.
- AC Power Outlet (GFCI Receptacle)** — Power cable is connected to this outlet to turn on lamps. Also allows electrical devices to be connected. When inserting plug into outlet, make sure that there is no contact failure and that the plug does not come off.  
  
The GFCI (Ground Fault Circuit Interrupter) shuts off power to the protected receptacles if a ground fault (electrical leak) is detected.
- Ground Terminal** — Connect earth ground to this connection point if required.
- ECO Mode Switch** — Used to activate “ECO mode” for reduced fuel consumption and noise, depending on power consumption.
- Engine Switch** — Switches the power on and off.
- Fuel Cock/Choke Knob** — Controls the flow of fuel and choke opening/closing to start the engine after the engine switch is turned on.
  - **OFF:** Default position. Turn to this position when stopping, storing, or transporting the generator. Fuel does not flow.
  - **ON:** Turn to this position when starting the engine while it is hot (in the summer or for restarting). Fuel flows.
  - **CHOKE:** Turn to this position when starting the engine while it is cold. Fuel flows and the choke is controlled. Pull the recoil starter grip, and turn to “ON” a few moments after the engine is started.

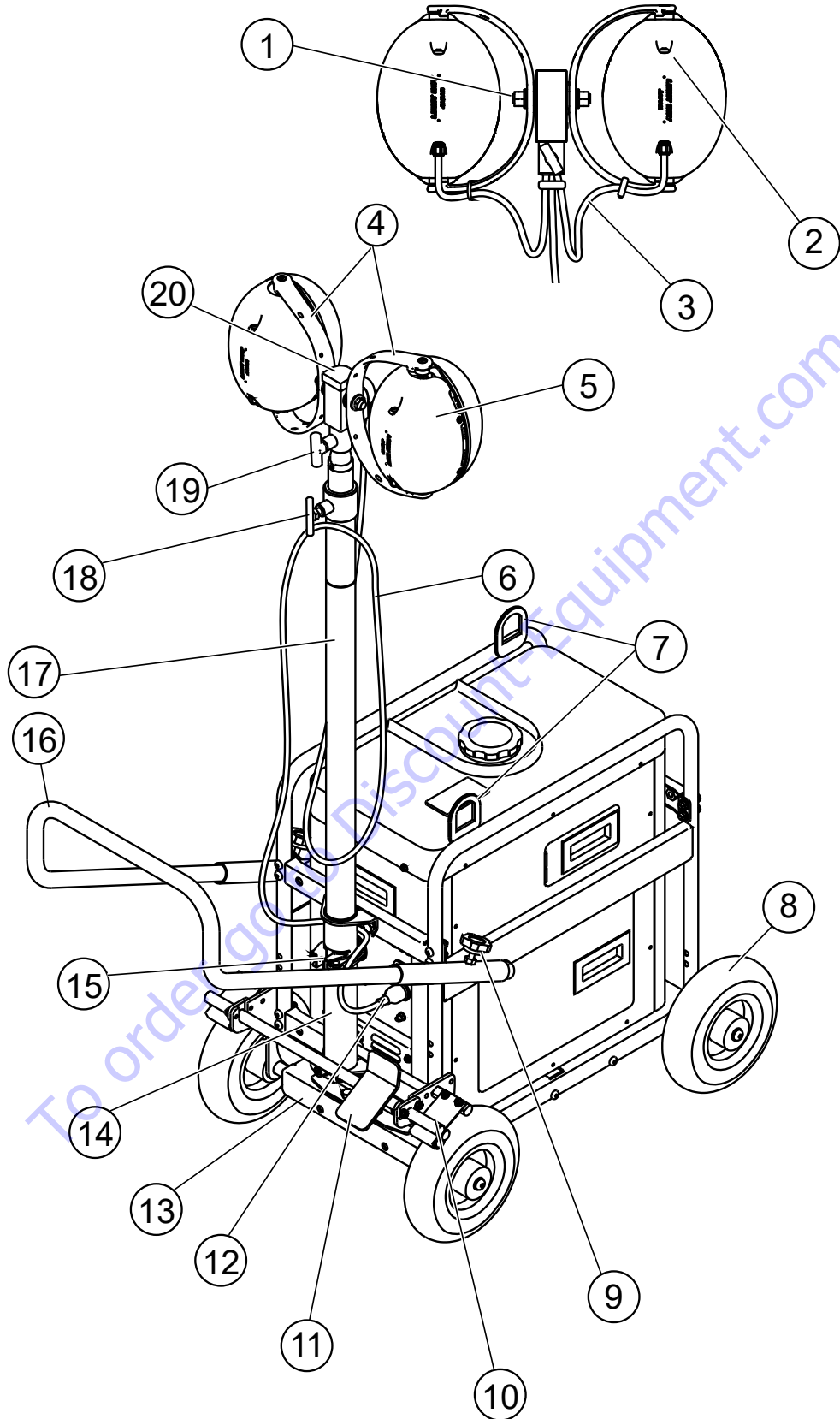

Figure 4. GBX4S Components

## COMPONENTS

Refer to Figure 4 for the location of the components listed below.

1. **Lock Nut** — Locks the lamp in place.
2. **Dimmer Switch** — At start up, lamps are lit at 200W. Pressing the dimmer switch changes the brightness in the following sequence:  
200W — 100W — 35W — OFF — 200W
3. **Lamp Cable** — Connects the lamp assemblies to the power output of the generator.
4. **Lamp Arm** — Holds the lamp and permits multiple directional adjustments.
5. **Lamp** — 200 Watt LED lamp with industrial grade, impact and weather resistant shell enclosure.
6. **Power Cable** — Connects to the AC power source.
7. **Lifting Eye** — Use the lifting eyes when required to transport the unit via a supportive chain or strap. **NEVER** stand underneath the GBX4S while it is being lifted.
8. **Tires** — The GBX4S utilizes 4 air tires with 8.7-inch diameter (220 mm). Replace with only recommended type tire. **NEVER** allow the tires to go flat.
9. **Handle Knobs** — Loosen knobs to pull out handle. Tighten knobs when handle is in the desired position.
10. **Brake** — When the brake pedal is pushed downward, the brake will hold the cart in place.
11. **Brake Pedal** — Step on the brake pedal downward to apply the brakes. Step on this pedal forward to release the brakes.
12. **Power Cable Plug** — Connects the power cable to the AC power source.
13. **Cart** — Holds the generator and lamps and can be steered easily to transport GBX4S to different locations.
14. **Mast Holder** — Holds the mast in place.
15. **Mast Clamp** — Secures the mast to the holder.
16. **Handle** — Moves the GBX4S in either forward or reverse direction by pulling back or pushing forward.
17. **Mast** — This mast is comprised of a telescopic system with three different heights (air brake).
18. **Mast Knob** — Loosen to raise 2nd mast and tighten to keep the mast in place when raised to the desired height.
19. **Lampstand Knob** — Secures the lampstand to the mast.
20. **Lamp Switch** — Turns lamp on or off.

# GENERATOR COMPONENTS

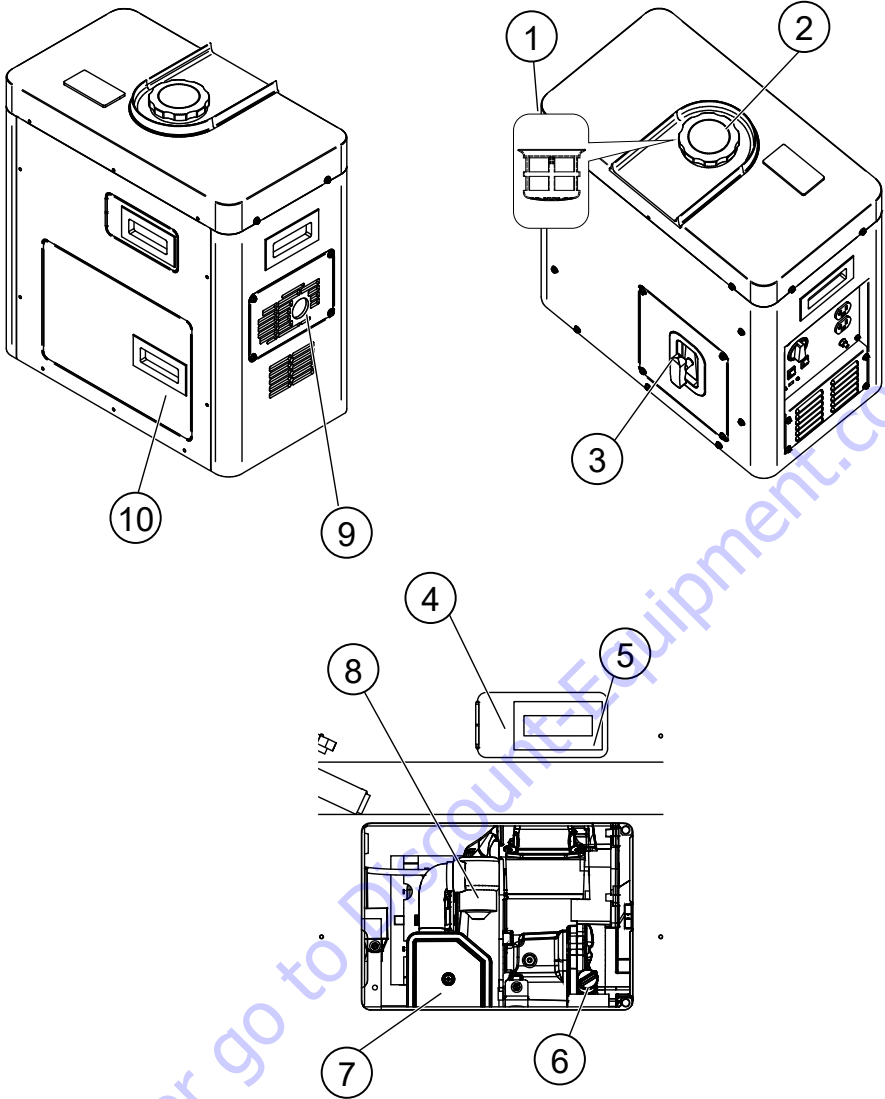



Figure 5. Generator Components

# GENERATOR COMPONENTS

Refer to Figure 5 or the location of the components listed below.

1. **Strainer** — Prevents dirt and other debris from entering the fuel tank.
2. **Fuel Tank Cap** — Remove this cap to add unleaded gasoline to the fuel tank. Make sure cap is tightened securely. DO NOT over fill.

 **DANGER**



Adding fuel to the tank should be done only when the engine is stopped and has had an opportunity to cool down. In the event of a fuel spill, **DO NOT** attempt to start the engine until the fuel residue has been completely wiped up, and the area surrounding the engine is dry.

3. **Recoil Starter Grip** — Pull the starter grip until resistance is felt, then pull briskly and smoothly.
4. **Spark Plug Cover** — Open cover to access spark plug.
5. **Spark Plug** — Provides spark to the ignition system. Set spark plug gap to 0.6 - 0.7 mm (0.028 - 0.031 inch). Clean spark plug once a week.
6. **Oil Plug/Filler Port** — Remove plug and fill port with recommended oil.
7. **Air Cleaner** — Prevents dirt and other debris from entering the fuel system.
8. **Carburetor** — Combines gasoline and air creating a highly combustible mixture, regulates the ratio of air and fuel, and controls the engine's speed.
9. **Exhaust Port** — Allows exhaust to come out of engine.
10. **Oil Maintenance Cover** — Open this cover to access engine for maintenance.

## PREPARATION

1. Place light cart on a level operating area with enough clearance as not to interfere with any overhead obstruction.
2. Ensure the on-board mechanical brake is employed once the unit is placed in its operating space.

### **! DANGER**

ALWAYS make sure the area above light cart is open and clear of overhead power lines and other obstructions. The mast extends in excess of 10.7 ft. (3.26 meters). Contact with overhead power lines or other obstructions could result in equipment damage, serious injury or death!

3. Step down on the brake pedal to make sure that the cart is locked in place. (Figure 6).

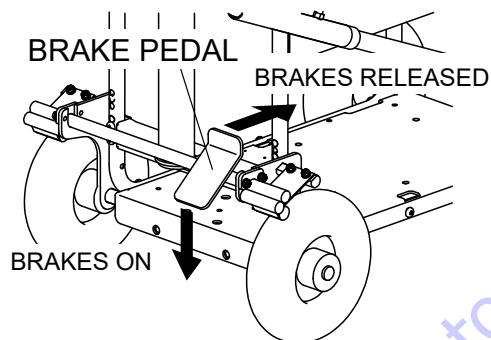

**Figure 6. Brake Pedal**

## MAST INSTALLATION

1. Insert the mast into the mast holder (Figure 7).

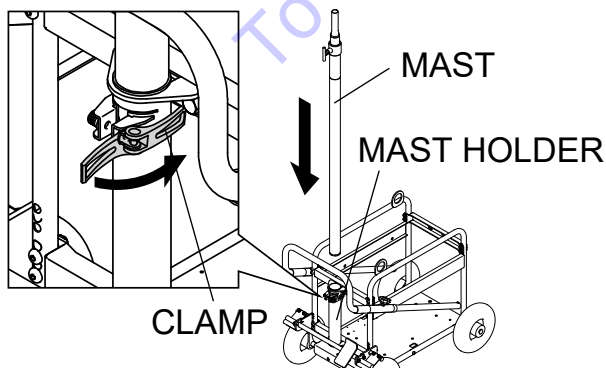

**Figure 7. Mast Installation**

2. Lock the mast in place by fastening the clamp tightly.

### **! DANGER**

Make sure to tighten the clamp. If it is loose, the mast may come off causing injury and damage to the unit.

## LAMP INSTALLATION

1. Insert the lampstand vertically into the mast (Figure 8).

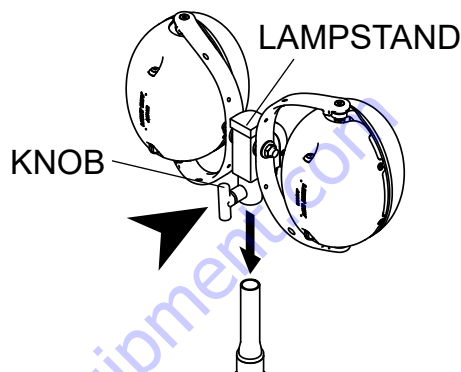

**Figure 8. Lamp Installation**

2. Tighten the lampstand knob to secure the lampstand.

### **! DANGER**

Make sure to tighten the knob. If it is loose, the lampstand may come off causing injury and damage to the unit.

## CHANGING LAMP DIRECTION

The mast can be rotated to change the direction that the lamps are facing. The lamps can also be rotated individually.

### Rotating the Mast

1. Unscrew the mast knob to release the mast for rotation (Figure 9).

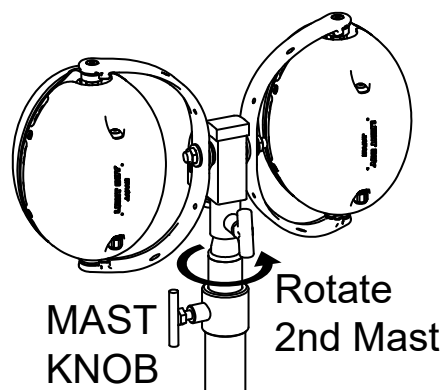
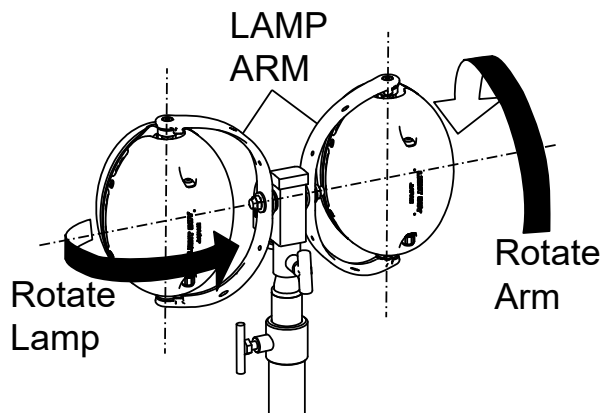

**Figure 9. Rotating the Mast**

2. Rotate the mast until the lamps are facing the desired direction.
3. Tighten the mast knob to lock the mast in place.

## Rotating the Lamps

1. Hold the arm of the individual lamp and rotate it to the desired direction (Figure 10). It is not necessary to loosen the nut to turn the lamps.



**Figure 10. Rotating Lamp Arm**

2. To rotate the lamp to a desired angle, hold the individual lamp and rotate (Figure 10).

### **CAUTION**

When rotating the lamp, keep fingers clear of the pinch points to prevent injury.

## EXTENDING THE MAST

### **DANGER**

**ALWAYS** make sure the area above light cart is open and clear of overhead power lines and other obstructions. The tower extends in excess of 10.7 ft. (3.26 meters). Contact with overhead power lines or other obstructions could result in equipment damage, serious injury or death!

### **CAUTION**

**ALWAYS** make sure the cart is on level ground with the brakes on before extending the mast.

1. Tighten the mast knob (Figure 11).

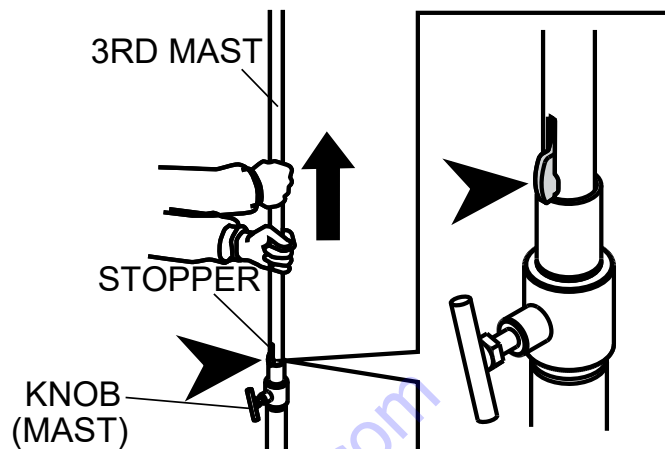

**Figure 11. Raising Third Mast**

2. Raise third mast until the stopper locks it in place (Figure 11).
3. Loosen the mast knob and extend the second mast to the desired height (Figure 12).
4. Tighten the mast knob when the desired height is reached.

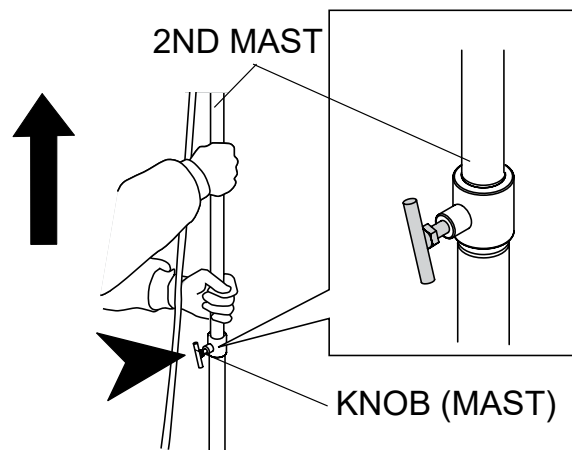

**Figure 12. Extending the Second Mast**

## HANDLE POSITIONING

1. Loosen the handle knobs on both sides of the cart (Figure 13).

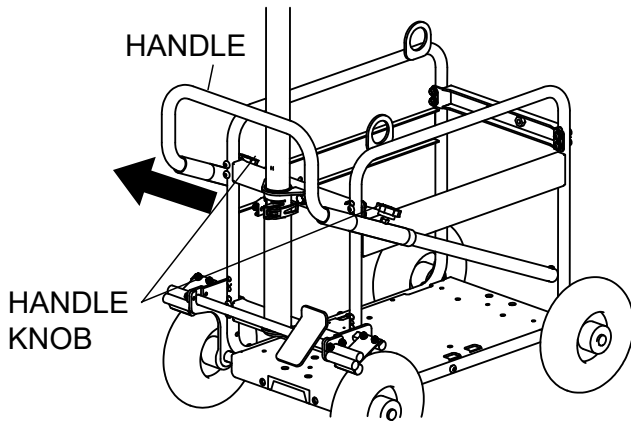

**Figure 13. Pulling the Handle Out**

2. Pull out the handle.
3. Tighten the handle knobs on both sides of the cart.
4. Push down the handle, lifting the front tires from the surface.
5. Move the handle to change direction of the cart with the rear tires.

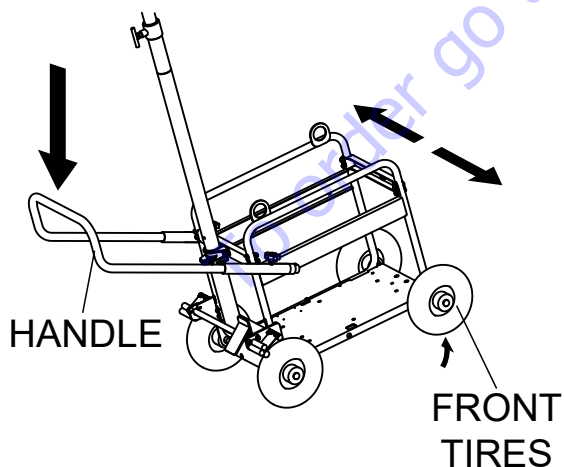

**Figure 14. Changing Direction with Rear Tires**

6. Lift up the handle, lifting the rear tires from the surface.
7. Move the handle to change direction of the cart with the front tires.

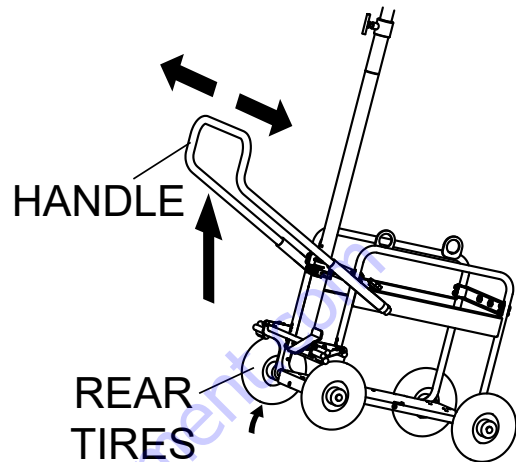
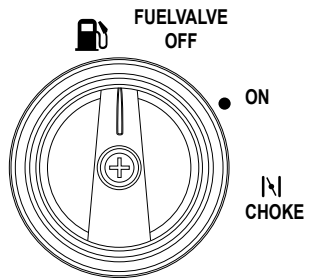

**Figure 15. Changing Direction with Front Tires**



## STARTING THE ENGINE

1. On the control panel, in warm weather, turn the fuel cock to the ON position (Figure 16).
2. In cold weather, turn the fuel cock to the CHOKE position when starting the engine.



**Figure 16. Fuel Cock (ON/CHOKE)**

3. Turn the Engine Switch to the ON position (Figure 17).

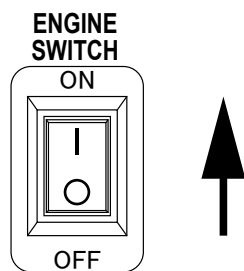

**Figure 17. Engine Switch**

4. Turn the ECO Mode Switch to the OFF position (Figure 18).

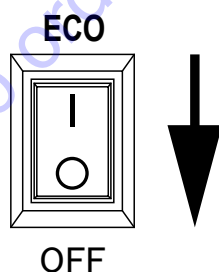

**Figure 18. ECO Mode Switch**

5. Pull the recoil starter grip until resistance is felt, then pull briskly and smoothly.(Figure 19).

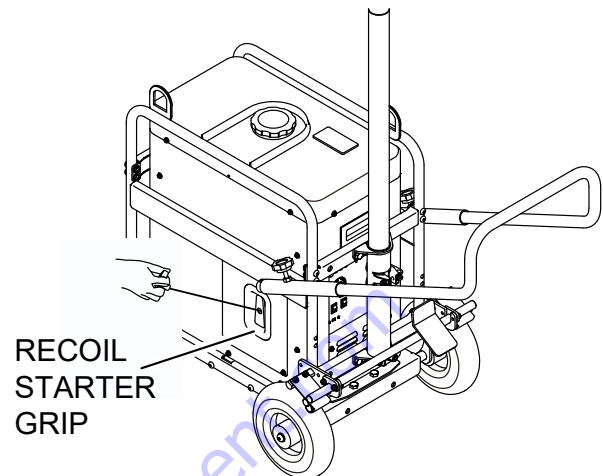

**Figure 19. Recoil Starter**

6. When the engine has started, slowly return the recoil starter grip to its original position.
7. When the engine has started, turn the fuel cock to the ON position if startup was at CHOKE position.
8. Let the engine run for 3 to 5 minutes to warm up.
9. Check that the output indicator stays on (green) (Figure 20). The overload alarm (red) will turn on for a few seconds at startup but this does not indicate an error.

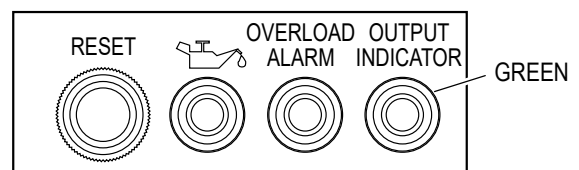

**Figure 20. Output Indicator (GREEN)**

10. If the overload alarm (red) stays on (Figure 21) instead of the of the output indicator (green):

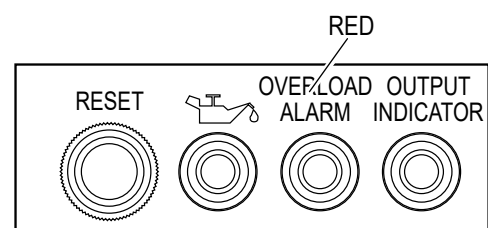

**Figure 21. Overload Alarm (RED)**

- Disconnect all electrical devices from the generator.
- Make sure that excessive power is not being used and that all electrical devices are within the rated power.

11. Press the output reset button (Figure 22) to reset the generator.

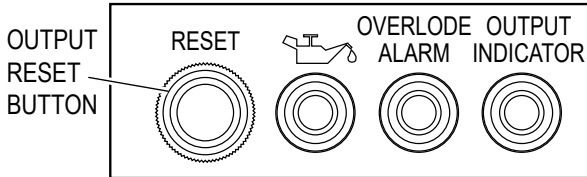

**Figure 22. Output Reset Button**

12. Refer to Table 4 for the list of indicator status and the action required.

**Table 4. Output Indicator and Overload Alarm**

Overload Alarm (Red)	Output Indicator (Green)	Cause	Action
Off	On	Normal Operation	
On	Off	Output of electrical power exceeding the rating from the AC outlet	Reduce the load
		Error detected in the device used	Inspect device used
		Clogged exhaust port (spark arrester)	Repair
		Generator error	Repair
Flashing	On	Immediately before overload protection	Reduce the load
Flashing 6x then off for 3 secs (repeated)	Off	Excessive use of power or error detected in the device used	Reduce the load
			Inspect device used
Flashing 3x then off for 3 secs (repeated)	Off	Abnormally high generator temperature	Stop the engine and allow it to cool down
Other		Repair	

## ECO MODE

Activate ECO mode for reduced fuel consumption and noise, depending on power consumption.

1. To activate ECO mode, place the ECO mode switch to the ECO position (Figure 23) while engine switch is on. When electrical devices are used, the engine speed is adjusted to support the actual power consumption. When electrical devices are not used, the engine automatically operates at low speed. Fuel consumption and noise are reduced in this mode.

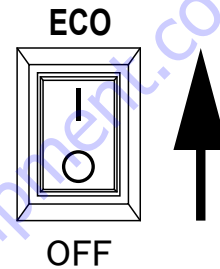

**Figure 23. ECO Mode Switch (Activate)**

2. To deactivate ECO mode, place the ECO mode switch to the OFF position. Whether electrical devices are used or no, the engine operates at the rated speed.

### NOTICE

- Turn ECO mode switch to OFF before starting the engine.
- Turn this switch to OFF when using electrical devices that consume a large amount of current during startup, such as submersible pumps or compressors.
- If electrical devices cannot be used in ECO mode, stop the engine and try to generate electrical power with this switch OFF.
- Periodically turn the ECO mode switch to OFF to operate the generator at high speed, so as to prevent carbon buildup in the exhaust port (spark arrester).

## TURNING ON THE LAMPS

1. Connect the power cable to the AC power outlet on the generator (Figure 24).

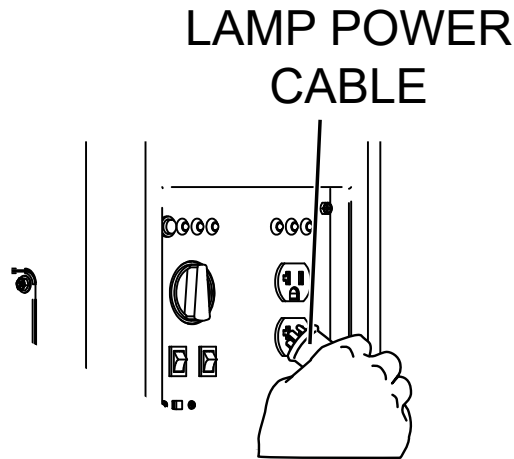

**Figure 24. Connecting to Generator**

### NOTICE

If using commercial power, plug the power cable to the commercial power supply receptacle.

2. The lamps light up at 200W, initially. Press the dimmer switch (Figure 25) on the lamp to change the brightness. Each press of the switch changes the lamp brightness in the following sequence:

200W — 100W — 35W — OFF — 200W

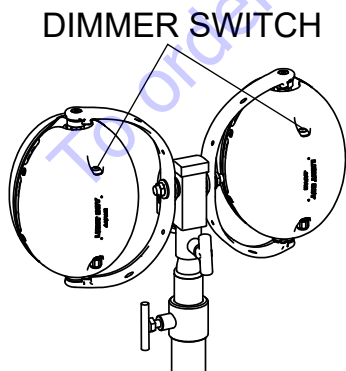

**Figure 25. Dimmer Switch**

3. Each dimmer switch is equipped with an indicator light to indicate how much power is consumed. See Table 5.

Power	Indicator Light	Fan
200 W	Lights	Working
100 W	Flash Once	Working
35 W	Flash Twice	Off
OFF	Flash Three Times	Off
ERROR	Flash Continuously	—

## ELECTRICAL DEVICE CONNECTION

External load (electrical device) can be connected to the dual 120 VAC GFCI power outlet (Figure 26).

### CAUTION

Do not use voltage-sensitive electrical devices as this generator adjusts voltage depending on the usage conditions of connected electrical devices.

### CAUTION

Do not connect or use faulty (damaged) electrical devices (including wire or plugs).

### NOTICE

Remove any dust, dirt, or water on the outlet before use.

1. Make sure that all power switches, on the electrical device to be connected, are off.
2. Plug the power cable of the electric device into the power outlet. Make sure the plug is inserted securely into the outlet. Total current consumption must be 13.3 A or less.

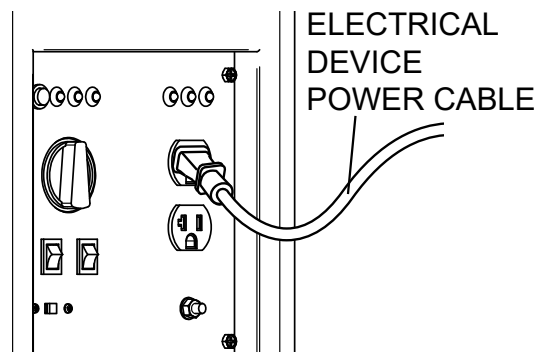

**Figure 26. Electrical Device Connection**

- The GFCI (Ground Fault Circuit Interrupter) shuts off power to the protected receptacles if a ground fault (electrical leak) is detected.
- If the reset button pops out, the electric device connected into the receptacle may be faulty. If this happens, check the electric devices carefully.
- If the electric device appears to be in good condition, press the reset button firmly until a click is heard. This will restore power.
- If the reset button pops out again, disconnect all electric devices immediately. Have the electric device inspected and repaired by a qualified repair person before attempting to use them again.

## AC POWER INDICATORS

The AC power indicators (Figure 27) allow you to check the power use status. See Table 6 for the power user status when certain indicators are on.

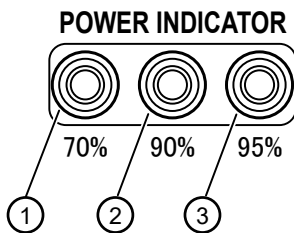

Figure 27. AC Power Indicators

Indicators	Power Use Status
All OFF	Using 0% to approx. 70% of maximum power
① ON	Using approx. 70% to 90% of maximum power
①② ON	Using approx. 90% to 95% of maximum power
①②③ ON	Using approx. 95% of maximum power or more

## NORMAL SHUTDOWN

- Unplug all devices connected to the 120 VAC GFCI power outlet.
- Make sure ECO mode switch is in the OFF position.
- Turn the fuel cock to the OFF position.
- Wait (about 3 minutes) for the engine to stop.

### NOTICE

If the generator is still operating after three minutes, check that the ECO mode switch is in the OFF position. If it is still operating even when the ECO mode switch is OFF, the fuel cock may be incorrectly aligned with the "Fuel OFF" position or may be malfunctioning

- Turn the engine switch to the OFF position once the engine has stopped.

## EMERGENCY SHUTDOWN

- Turn the engine switch to the OFF position.

### NOTICE

After an emergency stop, perform the normal shutdown procedure before storage.

## LOWERING THE MASTS AFTER USE

- Loosen the mast knob and lower the 2nd mast.

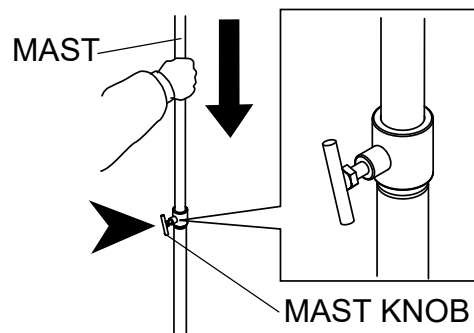

Figure 28. Lowering 2nd Mast

- Release the stopper by pressing it all the way in. Lower the 3rd mast.

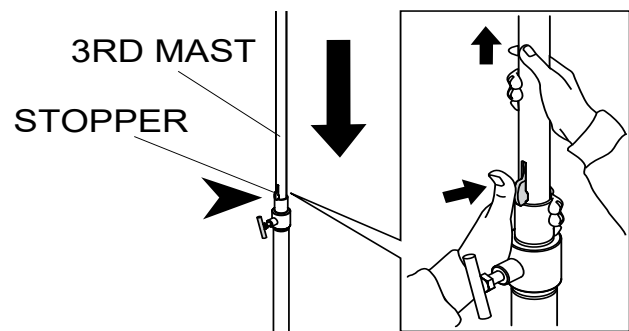
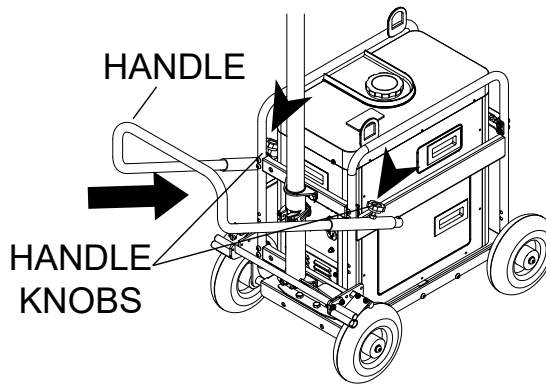

Figure 29. Lowering the 3rd Mast

## STOWING THE HANDLE

1. Loosen the handle knobs on both sides of the cart (Figure 30).



**Figure 30. Stowing the Handle**

2. Push the handle until it is completely in.
3. Tighten the handle knobs.

## PREPARATION FOR STORAGE

If the light cart is not going to be used for up to a month after initial operation, perform the following procedure.

4. Perform normal shutdown procedure.
5. Lower the masts.
6. Stow the cart handle.
7. Remove the fuel tank cap and strainer and drain the fuel using a commercially available manual gasoline pump.

### **! DANGER**

**DO NOT** use an electric pump to avoid the risk of fire.

8. Put back strainer and fuel tank cap making sure that cap is securely tightened.

### **! CAUTION**

Immediately wipe it off any spills completely with rags.

9. Start the engine as outlined in the Operations section.
10. Wait until the engine stops when it runs out of fuel (about 20 minutes).
11. Open the oil maintenance cover (Figure 31).

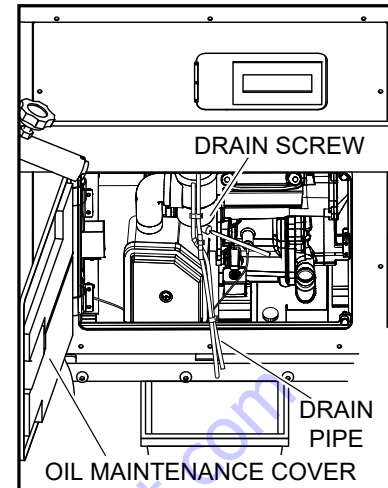

**Figure 31. Carburetor Fuel Drain**

12. Prepare a container to receive the gasoline to be drained.
13. Position the drain pipe from the carburetor so that the container is directly under it.
14. Using a screwdriver, loosen the drain screw to drain fuel from the carburetor.

### **! CAUTION**

Immediately wipe it off any spills completely with rags.

### **NOTICE**

If gasoline is not drained from the carburetor and remains in it for an extended period of time, gasoline deteriorates and the engine may not start.

15. Tighten the drain screw and return the drain pipe to its original position.
16. Turn OFF the engine switch and fuel cock.
17. Close the oil maintenance cover.

## LIGHT CART STORAGE

1. Wipe dirt or foreign matter that may have accumulated on the light cart during operation. Use a mild detergent to clean the unit. **DO NOT** spray the engine with water.
2. Avoid storing the light cart in areas that can be exposed to rain, harsh elements, and high humidity.
3. Place the light cart in a clean dry location away from dirt and debris.

# TRANSPORTING

## **!** DANGER

Empty the fuel tank before transporting the equipment. If not, gasoline may spill out from the cap of tank or carburetor causing a fire hazard.

## **!** CAUTION

When moving light cart on a slope, use a vehicle to transport instead of pushing through slope to avoid the cart tipping over.

## **!** CAUTION

Do not make sudden stops or turns when transporting with the forklift to prevent the light cart from falling off.

1. Before lifting light cart, make sure that the mast is completely lowered.
2. Use sling belts of sufficient strength with the lifting eyes to lift the light cart (Figure 32). Make sure that the light cart is balanced horizontally while lifting.

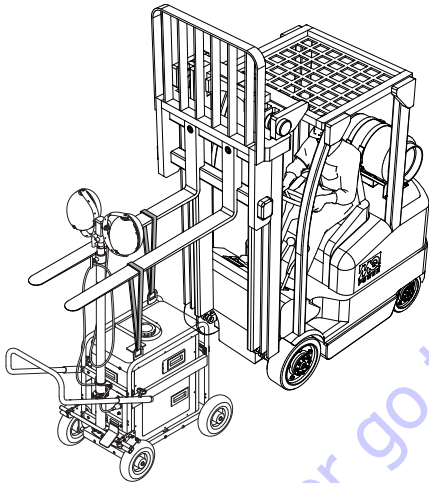

**Figure 32. Lifting the GBX4S Cart**

## **!** CAUTION

Make sure that the light cart is secure before transporting with the forklift. Failure to do so could cause the light cart to fall down and cause bodily injury to bystanders.

## GENERAL INSPECTION

When performing any maintenance on the light cart or engine, follow all safety messages and rules for safe operation stated at the beginning of this manual.

Prior to each use, the light cart should be cleaned and inspected for deficiencies. Check for loose, missing or damaged nuts, bolts or other fasteners. Also check for fuel or oil leaks.

### WARNING



Some maintenance operations may require the engine to be run. Ensure that the maintenance area is well ventilated. Exhaust contains poisonous carbon monoxide gas that can cause unconsciousness and may result in **DEATH**.

### CAUTION



**ALWAYS** allow the engine to cool before servicing. **NEVER** attempt any maintenance work on a hot engine.

To order go to Discount-Equipment.com

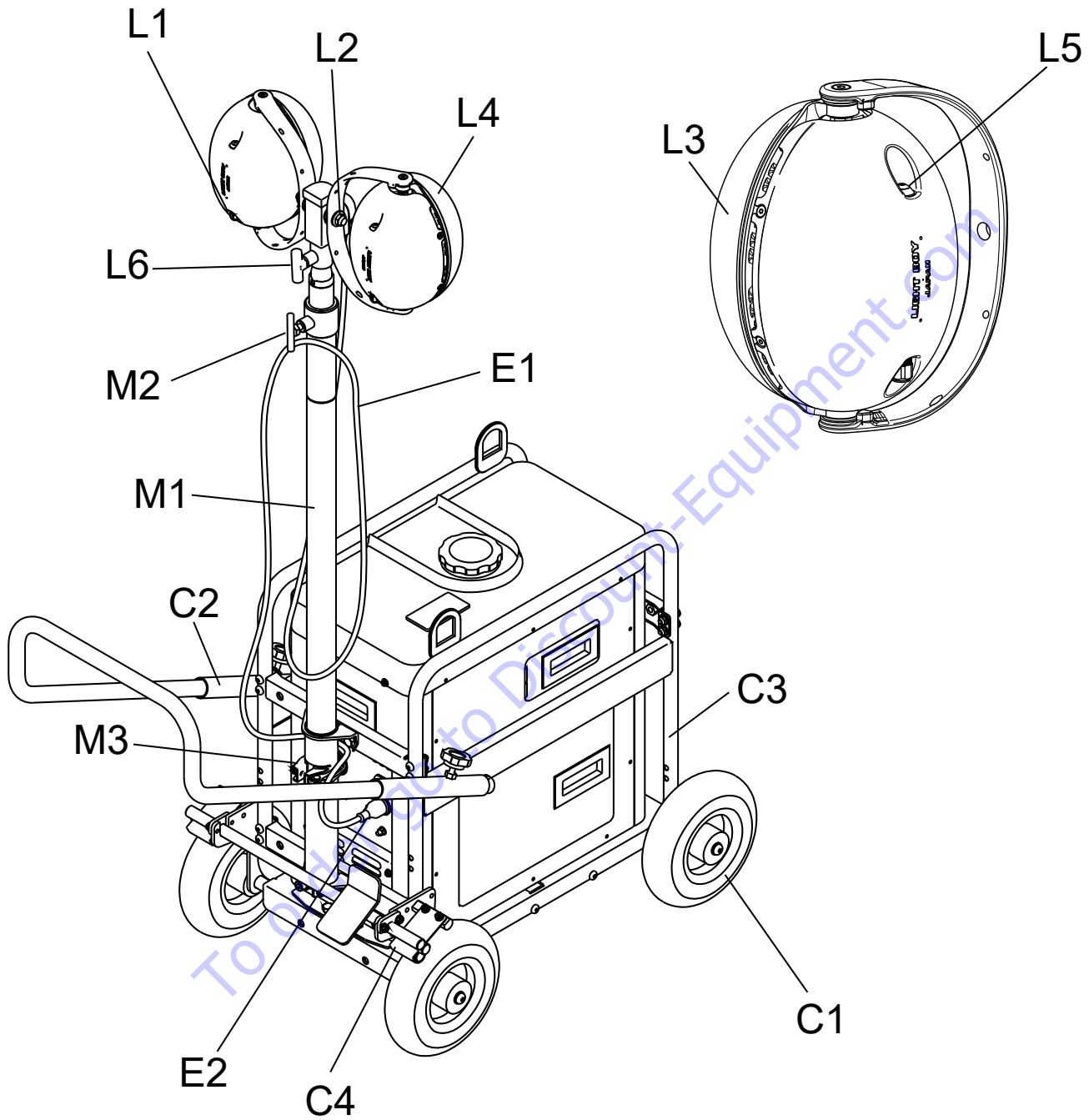

**Figure 33. Lamp/Mast Maintenance**



# MAINTENANCE

**Table 7. Light cart Maintenance**

Location	Part	Symptom	Solution	Freq.	
Lamp	L1	Cable Gland	Loose?	Tighten	❖
	L2	Locking Nut	Loose?	Tighten	❖
	L3	LEDs	No light? Damaged?	Replace	❖
	L4	Front Cover	Dirty?	Clean	❖
	L5	Dimmer Switch	Not working properly?	Replace	❖
	L6	Knob	Damaged?	Replace	■
Mast	M1	Mast	Bent or damaged?	Replace	■
	M2	Knob	Damaged?	Replace	■
	M3	Clamp	Damaged?	Replace	■
Cart	C1	Tires	Cracks? Flat?	Replace	❖
		Tire Pressure	Not 25 kgf/cm <sup>2</sup> ?	Correct	❖
	C2	Handle	Bent or damaged?	Replace	●
	C3	Frame	Bent or damaged?	Replace	●
	C4	Brakes	Not working properly? Damaged?	Replace	❖
Electric	E1	Cable	Cuts? Misshapen? Frayed?	Replace	❖
	E2	Plug	Damaged?	Replace	■
❖ - Daily Check Prior To Use      ■ - Every 20 Hours      ● - Every 100 hours					

# MAINTENANCE

## BASIC ENGINE MAINTENANCE

See Table 8 below for a general inspection and maintenance checklist.

Table 8. Engine Maintenance						
Engine Part	Inspection Item	Startup Inspection	Once a month or after 20 hours of operation following initial use	Once every 3 months or after 50 hours of operation	Once every 6 months or after 100 hours of operation	Once every 24 months
Engine Oil	Check Level	•				
	Replace		•		•	
Fuel	Check Level, Leaks	•				
	Inspection	•				
Air Cleaner	Clean		• <sup>3</sup>			
	Replace			• <sup>2</sup>		
Spark Plug	Inspect, Clean				•	
	Replace	Once every 250 hours of operation				
Fuel Strainer	Clean				•	
Fuel Pipe	Check for cracks and damage	•				
	Replace					• <sup>1</sup>
Exhaust Port (Spark Arrester)	Clean			• <sup>1</sup>		
Valve Clearance	Inspection and Adjustment				• <sup>1</sup>	
Cylinder Head, Piston	Carbon Removal	Once every 125 hours of operation <sup>1</sup>				

<sup>1</sup> — Proper tools and maintenance skills required. Contact dealer for inspection. Parts replacement is recommended to ensure safe and comfortable use for an extended period of time.

<sup>2</sup> — Only replace element in air cleaner.

<sup>3</sup> — When using the engine in a dusty environment, conduct daily inspection or once every 10 hours of operation.

## ENGINE OIL REPLACEMENT

1. Allow the engine to warm up for 2 to 3 minutes after startup. This facilitates draining of oil.
2. Turn the engine switch to the OFF position.
3. Allow the engine to cool before replacing engine oil.

### **WARNING**

Engine oil is extremely hot immediately after the engine is stopped after long-time operation which can cause burn injury..

4. Prepare a container for receiving drained engine oil.
5. Open the oil maintenance cover.
6. Remove the oil plug (Figure 34).

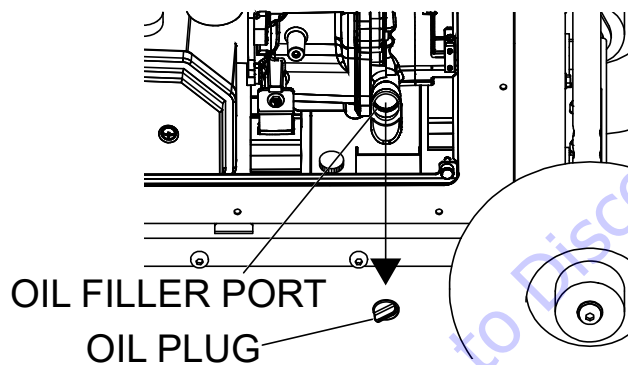

Figure 34. Removing Oil Plug

7. Tilt cart to drain the engine oil into the container (Figure 35).

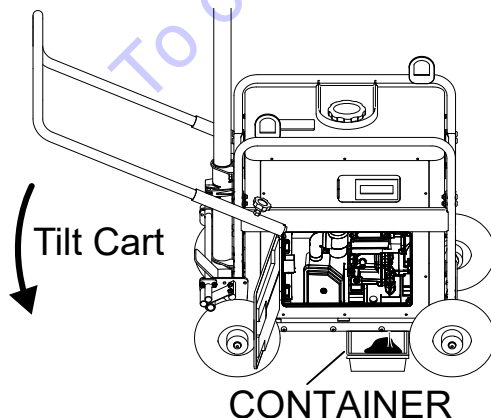

Figure 35. Draining the Oil

8. Once all the oil is drained, place the cart back in the horizontal position.
9. Replenish with 0.1 gallon (0.38 liter) of engine oil. Use recommended SAE 10W-30 oil type.

### **NOTICE**

Do not exceed the amount of oil specified when replenishing. Make sure oil does not go past lip of filler port. Wipe off any spilled oil.

10. Securely attach the oil plug and make sure it is not loose.
11. Close the oil maintenance cover.

## SPARK PLUG

1. Turn the engine switch to the OFF position to stop the engine.
2. Open the spark plug maintenance door (Figure 36).

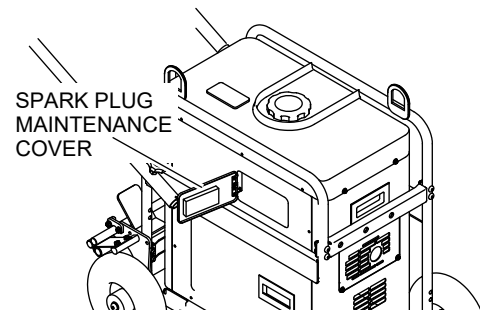

Figure 36. Spark Plug Maintenance Door

3. Remove the spark plug cap.
4. Insert the spark plug wrench so that the hexagonal section fits over the spark plug (Figure 37 ①).

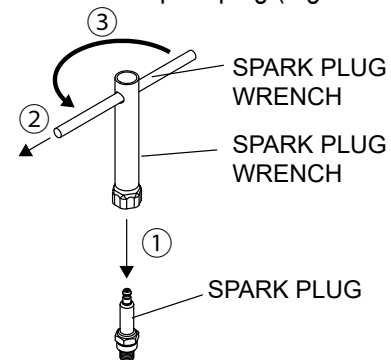

Figure 37. Spark Plug Removal

## MAINTENANCE

5. Insert the bar handle through the hole on the upper part of the spark plug wrench (Figure 37 ②).
6. Turn the handle counterclockwise to remove the spark plug (Figure 37 ③).

### CAUTION

Be careful not to damage the insulator (white ceramic section) during spark plug removal/attachment. A damaged insulator results in current leakage, running the risk of fire.

7. Wipe the spark plug with a clean rag, if wet or dirty.
8. If the area around the electrode has been burnt to a black or white color, or is wet with gasoline, use a parts cleaner to clean it. (The electrode normally turns brown.)
9. Check the gap between the electrodes (spark gap), and adjust it if not within the following measurement (Figure 38).

Spark gap: 0.024 - 0.028 inches (0.6 - 0.7 mm)

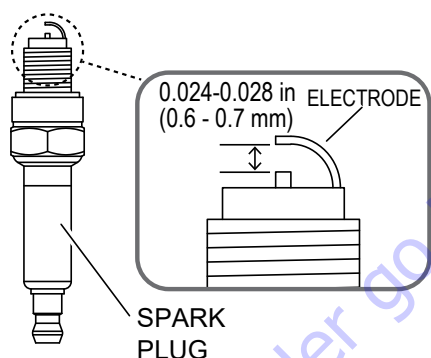

Figure 38. Spark Plug Gap

10. After adjustment or cleaning, reattach the spark plug to the spark plug wrench with the electrode facing downward. Carefully screw it by hand straight into its original position.

### NOTICE

Do not use the bar handle initially, to screw in the spark plug. It will be difficult to screw in the spark plug straight with the bar handle attached, possibly causing engine damage.

11. Once the spark plug is screwed in, attach the handle bar to the spark plug wrench and tighten the spark plug securely.
12. When replacing with a new spark plug, tighten it by hand and then firmly tighten it 1/4 to 1/2 turns with the spark plug wrench.
13. After inspection, adjustment, or replacement, securely attach the spark plug cap.

### NOTICE

Make sure spark plug cap is securely tightened. A loose cap can cause engine malfunction.

14. Close the spark plug maintenance cover.

### NOTICE

If the engine does not start even after cleaning the spark plug or adjusting its gap, replace with a new spark plug.

## AIR CLEANER

1. Turn the engine switch to the OFF position to stop the engine.
2. Open the oil maintenance door (Figure 39).



Figure 39. Removing Air Cleaner Cover

3. Remove the screw that attaches the air cleaner cover and remove the cover.
4. Remove the element (filter) from the air cleaner (Figure 40).

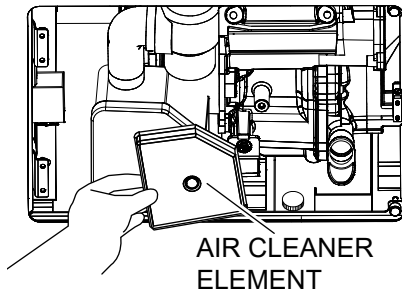

**Figure 40. Air Cleaner Element**

5. Wash the element with clean kerosene.

**CAUTION**

Cigarettes or other heat sources must be kept away as kerosene is flammable. Failure to do so may result to a risk of fire.

Wash the element in a well-ventilated location.

6. Thoroughly squeeze the element to remove the kerosene.

**NOTICE**

Do not twist the element. This could damage the element and cause engine malfunction.

7. Dip the element in engine oil and then press it to remove the oil.
8. Remove excess oil so that oil does not drip from the element.
9. Attach the element back to the air cleaner.

**NOTICE**

Securely attach the element so that it is not folded out or misaligned.

Never start the engine with the element removed. Doing so could cause engine failure.

10. Check that the seal rubber located between the air cleaner cover and the air cleaner is secure and not damaged.
11. Return the air cleaner cover to its original position and tighten the screw.
12. Close the oil maintenance cover.

## FUEL TANK STRAINER

1. Turn the engine switch to the OFF position to stop the engine.
2. Remove the fuel tank cap and strainer (Figure 41).

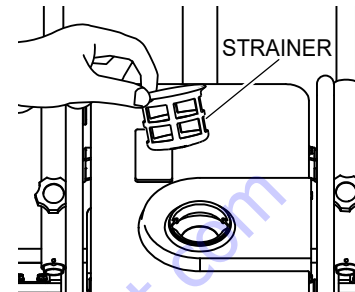

**Figure 41. Fuel Strainer Removal**

3. Wash the strainer with clean kerosene.
4. If strainer is damaged, replace with a new one.

**CAUTION**

Cigarettes or other heat sources must be kept away as kerosene is flammable. Failure to do so may result to a risk of fire.

Wash the strainer in a well-ventilated location.

5. Wipe the strainer and fully insert it into the fuel tank.
6. Attach the fuel tank cap and securely tighten.

## GFCI RECEPTACLE

1. Start the engine.
2. Press the test button and check the position of the reset button.
3. If reset button pops out, GFCI is working properly.
4. If reset button stays in, GFCI is defective. Consult your dealer immediately.

**WARNING**

Do not operate the light cart with a faulty GFCI circuit. Electric shock could occur. Have the generator repaired by a qualified mechanic.

# TROUBLESHOOTING

**Table 9. Light cart Troubleshooting**

SYMPTOM	POSSIBLE PROBLEM	SOLUTION
All LEDs on luminous surface are OFF.	Indicator blinking rapidly?	Press Dimming Control Switch once and see Check error code.
	Cooling fan running?	LED power supply failure. Replace.
	Indicator light blinks 3 times?	Charge or replace the battery.
	Indicator off and does not respond when pressed?	Device in off mode.
Several LEDs are OFF.	More than half of LEDs OFF?	Trouble on light emitting surface. Replace aluminum substrate.
Fan is not working.	Indicator blinking rapidly?	Press Dimming Control Switch once and see Check error code.
	Any foreign objects in fan?	Remove foreign objects or replace fan.
	Other problems?	LED power supply failure. Replace.
Abnormal noise coming out of fan.	Blades in contact with fan guard?	Deformed fan guard. Replace deformed parts.
	Any foreign objects in fan?	Remove foreign objects.
Input Voltage Problem	No power from power outlet?	Circuit breakers tripped. Reset circuit breaker.
	No AC between points 1 and 2 on wiring diagram?	AC cable failed. Replace.
	Power plug disconnected?	Connect cable.
	Cord reel used between power supply and floodlight?	Voltage drop. Direct connection between power supply and floodlight without using cord reel.
	Other device connected to power source?	Output rating exceeded. Remove another device and recheck.

## TROUBLESHOOTING

While indicator is blinking rapidly, press dimmer switch once. Count the number of blinks to determine error code. In error check mode, the unit is basically off except when the indicator light is blinking.

**Table 10. Error Code Check**

Indicator Blinks	Symptom	Problem	Solution
Twice	Fan-related malfunction	LED power supply failure?	Check cables and replace if there are problems
		Items other than fans are connected?	
		Cable 8/9 broken or disconnected?	
3 Times	LED-related malfunction	LED power supply failure?	
		Cable 4 broken or disconnected?	
4 Times	Power supply-related malfunction	AC overcurrent has occurred?	Stop and check generator. Correct problem (eg - by refueling) and retry.
		Input voltage fluctuation due to lack of fuel, etc?	
5 Times	Voltage Drop	AC voltage falls below 70V for 2 seconds or longer?	If problem recurs, replace LED power supply.
		AC voltage falls below 65V?	
More than 6 Times	Temperature-related malfunction	Power supply internal temperature exceeds 176°F (80°C)?	Discontinue use and allow to cool fully. If problem occurs repeatedly, replace LED power supply.
		Temperature of light emitting unit assembly exceeds 212°F (100°C)?	
		Cable 5 connecting light emitting unit assembly and power supply is broken or disconnected?	

# TROUBLESHOOTING

**Table 11. Engine Troubleshooting**

SYMPTOM	POSSIBLE PROBLEM	SOLUTION
It is impossible to pull the recoil starter grip, or resistance is felt when pulling it.	Sticking due to improper engine oil?	Replace with proper engine oil. If the problem persists, contact your dealer for repair or inspection.
	Engine seizure?	Do not repair by yourself. Contact your dealer for repair or inspection.
	Excessive engine oil?	
	Oil loss through piston due to this generator being tipped over?	
	Recoil starter problem?	
	Rust inside the engine?	
	Foreign matter in cylinder?	
Engine does not start.	Lack of fuel?	Replenish fuel.
	Oil warning lamp (red) remains on? Lack of engine oil or insufficient oil?	Replenish engine oil.
	Tilted generator? Oil alert mechanism is triggered?	Keep horizontal.
	Engine malfunction due to improper fuel or engine oil?	Replace with proper fuel or engine oil. If the problem persists, contact your dealer for repair.
	Improper engine start procedure?	Recheck correct engine startup procedure.
	Flooded, dirty, or damaged spark plug?	Inspect and then replace or adjust.
	Dirty air cleaner?	Clean the air cleaner.
	Water in the fuel tank or carburetor?	Loosen the carburetor screw to drain water.
	Incorrect position of the fuel cock/choke knob?	Turn to "Run" position if the engine is hot or in summer.
		Turn to "Start" position if the engine is cold or in winter.
	Oil loss through piston due to this generator being tipped over?	Do not repair by yourself. Contact your dealer for repair or inspection.
	Clogged carburetor or exhaust port (spark arrester)?	
	Problem persists even after taking corrective action. Internal engine damage?	



# TROUBLESHOOTING

**Table 11. Engine Troubleshooting (continued)**

SYMPTOM	POSSIBLE PROBLEM	SOLUTION
Engine stops after operating for a few minutes.	Engine malfunction due to improper fuel or engine oil?	Replace with proper fuel or engine oil. If the problem persists, contact your dealer for repair.
	Degradation of the spark plug or ignition coil?	Inspect or replace the spark plug.
	Clogged carburetor?	Do not repair by yourself. Contact your dealer for repair or inspection.
	Tilted Light cart?	Place on a level area.
	Insufficient warm-up operation?	Perform warm-up operation.
	Large amount of power is suddenly used to operate several electrical devices?	Level out the power consumption.
Loud popping noise is generated near the muffler (afterfire caused at startup).	The recoil starter was operated repeatedly until engine startup, resulting in the combustion of unburned gas near the muffler (afterfire)?	Inspect or replace the spark plug. Recheck the correct engine startup procedure.
Power is not available.	Overload warning lamp (red) goes on or flashes, and output lamp goes off?	Remove the cause of overload or the error of the devices used.
	ECO mode is being used under the following conditions: <ul style="list-style-type: none"> <li>• Electrical devices that consume a large amount of current at startup, such as submerged pumps or compressors, are used?</li> <li>• The cigarette socket is used?</li> </ul>	Turn the ECO mode switch to OFF.
	The generator is covered with a box or sheet, or being used indoors, thereby increasing the generator temperature?	Check the surrounding area of the generator or use it outdoors.
Insufficient electrical device output	Electrical device is not compatible with this generator?	Consult with the manufacturer of the electrical device being used for proper connection.
ECO mode cannot be used	Even if the rated power is not reached, devices that use a large amount of power are connected?	Use in normal operation mode.
	Electric devices that consume a large amount of current at startup, such as submersible pumps or compressors, are connected?	
Lamps flash in a different manner than specified in Table 4?		Do not repair by yourself. Contact your dealer for repair or inspection.

# WIRING DIAGRAM

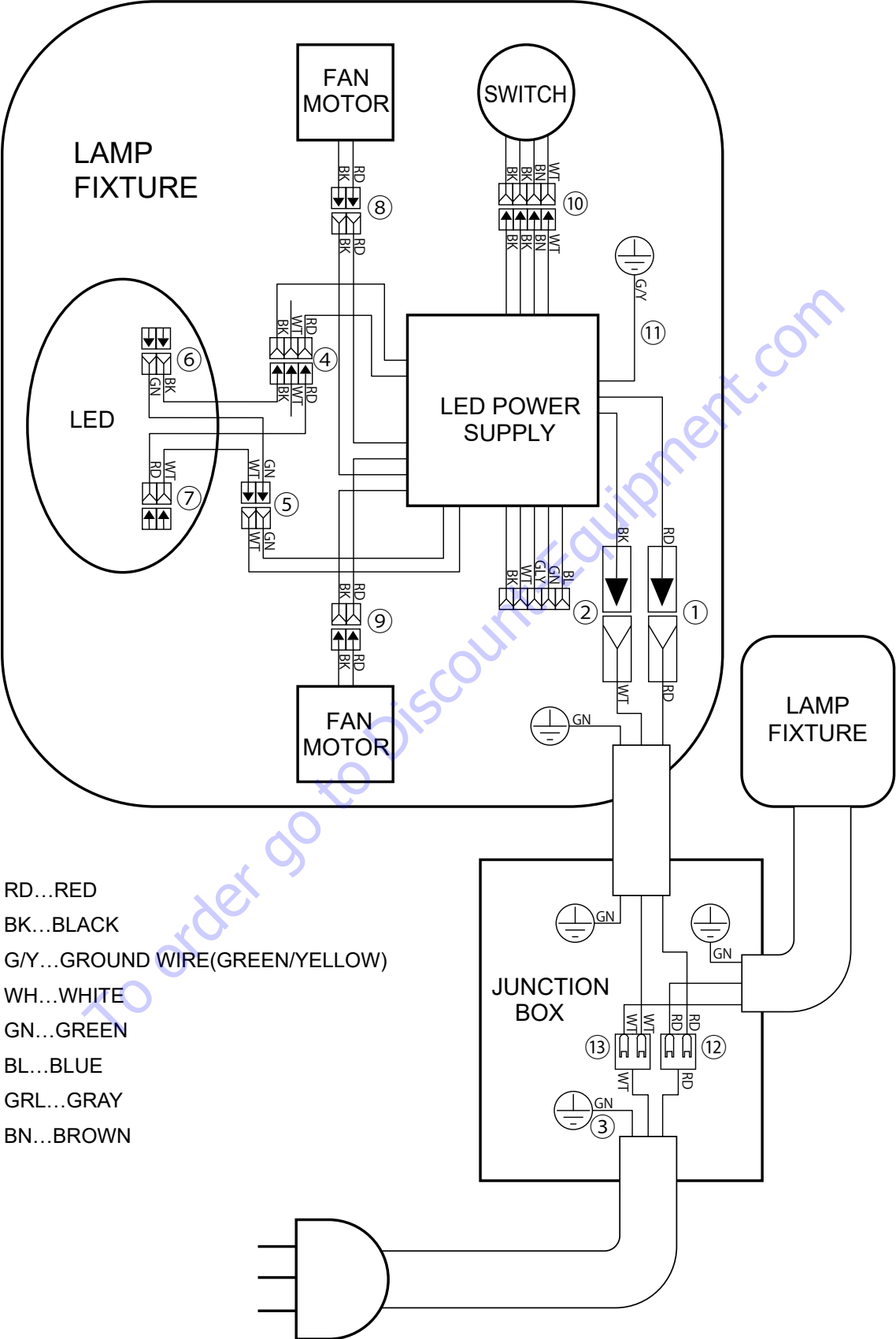

- RD...RED
- BK...BLACK
- G/Y...GROUND WIRE(GREEN/YELLOW)
- WH...WHITE
- GN...GREEN
- BL...BLUE
- GRL...GRAY
- BN...BROWN

**TO PURCHASE THIS PRODUCT PLEASE CONTACT US**



**Equipment Financing and  
Extended Warranties Available**



**Discount-Equipment.com is your online resource for  
commercial and industrial quality parts and equipment sales.**

**561-964-4949**

**visit us on line @ [www.discount-equipment.com](http://www.discount-equipment.com)**

Select an option below to find your Equipment

**Search by Manufacturer**

**Search by Product Type**

**Request a Quote**

We sell worldwide for the brands: Genie, Terex, JLG, MultiQuip, Mikasa, Essick, Whiteman, Mayco, Toro Stone, Diamond Products, Generac Magnum, Airman, Haulotte, Barreto, Power Blanket, Nifty Lift, Atlas Copco, Chicago Pneumatic, Allmand, Miller Curber, Skyjack, Lull, Skytrak, Tsurumi, Husquvarna Target, Stow, Wacker, Sakai, Mi-T-M, Sullair, Basic, Dynapac, MBW, Weber, Bartell, Bennar Newman, Haulotte, Ditch Runner, Menegotti, Morrison, Contec, Buddy, Crown, Edco, Wyco, Bomag, Laymor, EZ Trench, Bil-Jax, F.S. Curtis, Gehl Pavers, Heli, Honda, ICS/PowerGrit, IHI, Partner, Imer, Clipper, MMD, Koshin, Rice, CH&E, General Equipment, Amida, Coleman, NAC, Gradall, Square Shooter, Kent, Stanley, Tamco, Toku, Hatz, Kohler, Robin, Wisconsin, Northrock, Oztec, Toker TK, Rol-Air, APT, Wylie, Ingersoll Rand / Doosan, Innovatech, Con X, Ammann, Mecalac, Makinex, Smith Surface Prep, Small Line, Wanco, Yanmar

# OPERATION MANUAL

## HERE'S HOW TO GET HELP

PLEASE HAVE THE MODEL AND SERIAL  
NUMBER ON-HAND WHEN CALLING

---

To order go to [Discount-Equipment.com](http://Discount-Equipment.com)



[www.Discount-Equipment.com](http://www.Discount-Equipment.com)

