



PARTS LIST MANUAL

Model TG-10



NOTE:
Shown w/ optional
Ball Caster Depth Stop

10" Turbo Grinder



PARTS FINDER

**Search Website
by Part Number**



**Search Manual
Library For Parts
Manual & Lookup Part
Numbers – Purchase
or Request Quote**

Search Manuals

Enter your information to help us find the right parts manual for your machine.

* Brand:

* Model:

* Serial:

* Part Number:

SEARCH

**Can't Find Part or
Manual? Request Help
by Manufacturer,
Model & Description**

Parts Order Form

Please fill in the following information to help us find the right part for your machine.

Manufacturer:	<input type="text"/>
Model:	<input type="text"/>
Description:	<input type="text"/>
Part Number:	<input type="text"/>
Quantity:	<input type="text"/>
Notes:	<input type="text"/>

Discount-Equipment.com is your online resource for quality parts & equipment.

Florida: **561-964-4949** Outside Florida TOLL FREE: **877-690-3101**

Need parts?

Click on this link: <http://www.discount-equipment.com/category/5443-parts/> and choose one of the options to help get the right parts and equipment you are looking for. Please have the machine model and serial number available in order to help us get you the correct parts. If you don't find the part on the website or on one of the online manuals, please fill out the request form and one of our experienced staff members will get back to you with a quote for the right part that your machine needs.

We sell worldwide for the brands: Genie, Terex, JLG, MultiQuip, Mikasa, Essick, Whiteman, Mayco, Toro Stone, Diamond Products, Generac Magnum, Airman, Haulotte, Barreto, Power Blanket, Nifty Lift, Atlas Copco, Chicago Pneumatic, Allmand, Miller Curber, Skyjack, Lull, Skytrak, Tsurumi, Husquvarna Target, Stow, Wacker, Sakai, Mi-T-M, Sullair, Basic, Dynapac, MBW, Weber, Bartell, Bennar Newman, Haulotte, Ditch Runner, Menegotti, Morrison, Contec, Buddy, Crown, Edco, Wyco, Bomag, Laymor, EZ Trench, Bil-Jax, F.S. Curtis, Gehl Pavers, Heli, Honda, ICS/PowerGrit, IHI, Partner, Imer, Clipper, MMD, Koshin, Rice, CH&E, General Equipment, Amida, Coleman, NAC, Gradall, Square Shooter, Kent, Stanley, Tamco, Toku, Hatz, Kohler, Robin, Wisconsin, Northrock, Oztec, Toker TK, Rol-Air, APT, Wylie, Ingersoll Rand / Doosan, Innovatech, Con X, Ammann, Mecalac, Makinex, Smith Surface Prep, Small Line, Wanco, Yanmar

READ AND UNDERSTAND THE OPERATORS INSTRUCTION MANUAL THOROUGHLY BEFORE ATTEMPTING TO OPERATE THIS EQUIPMENT. Death or serious injury could occur if this machine is used improperly.



SAFETY MESSAGES



The safety instructions are preceded by a graphic alert message of DANGER, WARNING, or CAUTION.



Indicates an imminent hazard which, if not avoided, will result in death or serious injury.



Indicates an imminent hazard which, if not avoided, can result in death or serious injury.



Indicates hazards which, if not avoided, could result in serious injury and or damage to the equipment.

GASOLINE

Powered Equipment



- Do not operate gasoline powered equipment without adequate ventilation. Carbon monoxide is an invisible, odorless gas that can kill.

ELECTRICAL

Powered Equipment



- ELECTRICAL HAZARD** - Be sure equipment is properly grounded. Failure to comply could kill or result in serious injury.



The engine exhaust from this product contains chemicals known to the State of California to cause cancer, birth defects or other reproductive harm.

GENERAL INSTRUCTIONS



- You must read and understand the operators instruction manual and all other manuals associated with this machine. For your safety and the safety of others around you, it is extremely important to fully understand how to operate this machine in the way it was intended. Different model machines or older/newer versions of the same model may have different parts and controls that you need to understand. If instructions are not readable or available DO NOT USE this machine and contact Discount-equipment for a replacement Manual.
- You must be able to physically handle the bulk weight and power of this machine. If not properly controlled this machine can cause death or serious injury.
- Do not operate this machine in an impaired mental state. You must be able to exercise good judgement and reactions to maintain a safe working environment.
- This is a "one person" machine which means only one operator can be operating the machine at any one time. For the safety of others, maintain a safe operating distance to other personnel. Your work area should be defined and appropriately marked so bystanders and coworkers do not stand or walk near this machine and end up seriously injured by flying debris or exposing them to harmful noise or dust.
- This equipment is for Commercial use. Although this is a "one person" machine your work team should understand how to shut this machine off and quickly get medical help if an accident strikes the operator.
- Keep all guards in place during operation. The guards are to provide protection from inadvertent contact with dangerous moving parts, pinch points, or hot surfaces.
- Wear appropriate Personal Protective Equipment (PPE) including safety glasses, safety boots, work gloves, respiratory protection,

hearing protection, and head protection. Do not wear loose clothing that can get tangled in moving parts. Failure to do so could result in dismemberment or death. **Wear an approved respirator when removing hazardous materials or when grinding/cutting dry materials. Some dust particles such as concrete dust can contain silicate particles which can cause silicosis (a very serious lung disease). Contact NIOSH or OSHA for further details. When wet grinding/cutting, avoid contact with the concrete/asphalt slurry which can cause serious skin irritations.**

- You must maintain this machine per the maintenance schedule in the operator manual. Remember before adjusting, servicing, or fueling this machine, disconnect the source of power to the machine by disconnecting the spark plug (Gas models), or by unplugging the electrical power cord (electric models) or air hose (Pneumatic models) AT THE MACHINE so you can assure yourself it remains unplugged while you are working on it. Do not modify this machine. Use only genuine EDCO parts and accessories. Repairs and service should be performed by approved EDCO dealers or authorized technicians.
- You should look carefully around the area before you begin work so you can identify potential hazards such as deck inserts, pipes, columns, openings, electrical cords or outlets, or any other objects protruding from the slab surface.
- This machine has no brain so you must use your own. There is no substitute for safety. The safety decals on the machine are to serve as a reminder for information you must already know before you begin using this machine. Take a moment to reread the safety decals each time you use the machine. If your machine is missing any decals, contact Discount-equipment for a replacement.

PARTS LIST MANUAL

EDCO MODEL

Section	Page Number
Safety Messages and General Instructions	2
How To Order Replacement Parts	3
Illustration # 1: Main Frame Grouping	4
Parts Listing - Illustration # 1 : Main Assembly Grouping	5
Illustration # 2: Head Assembly	6
Parts Listing - Illustration # : Head Assembly	7
Illustration # 3: Engine Grouping	8
Parts Listing - Illustration # 3 : Engine Grouping	9
Illustration # 4: Propane Option	10
Parts Listing - Illustration # 4 : Propane Option	11
Illustration # 5: Motor Grouping	12
Parts Listing - Illustration # 5 : Motor Grouping	13
Illustration # 6: Optional Ball Caster Depth Stop Kit & Weight	14
Parts Listing - Illustration # 6 : Optional Ball Caster Depth Stop Kit & Weight	15
Limited Equipment Warranty	back cover

ILLUSTRATION #1: MAIN ASSEMBLY GROUPING

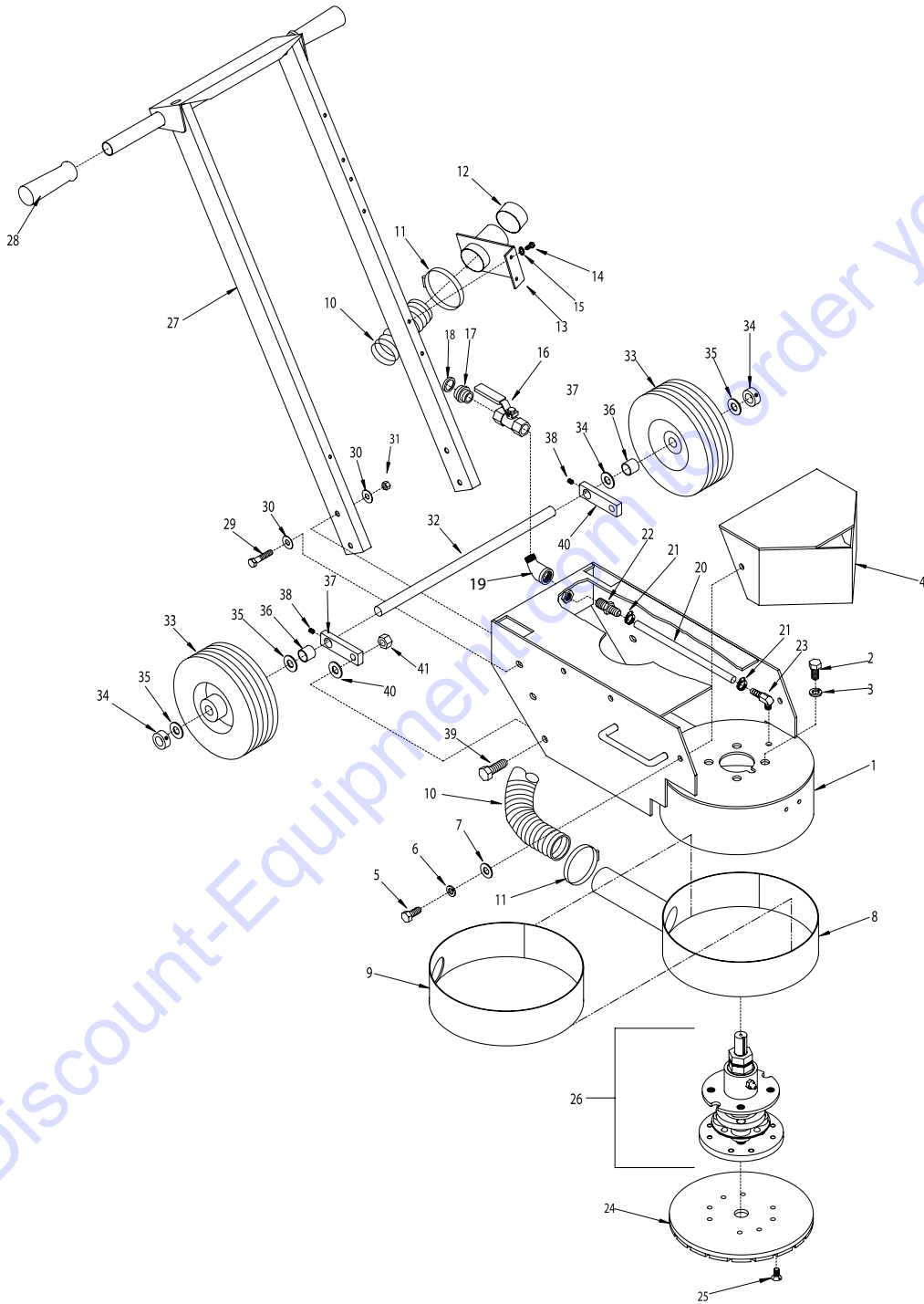

PARTS LISTING - ILLUSTRATION # 1: MAIN ASSEMBLY GROUPING

ITEM#	PART#	DESCRIPTION	QTY.
1	86301	MAIN FRAME	1
2	10321	SCREW, CAP 1/2-20 x 1-1/4	4
3	10045	WASHER, LOCK 1/2	4
4	86303	HOOD	1
5	10907	SCREW, CAP 3/8-16 x 3/4	2
6	10811	WASHER, LOCK 3/8	2
7	10025	WASHER, FLAT 3/8	2
8	86302	SKIRT	1
9	86317	RUBBER, SKIRT	1
10	86328	HOSE, FLEXIBLE, 2" ID x 34-1/2	1
11	10745	CLAMP, HOSE, SAE #36, ADJ. TO 2-3/4"	2
12	65021	PLUG, CAP 2"	1
13	86307	VAC. PORT BRACKET, 2"	1
14	10877	SCREW, CAP STSHW 10-24 x 1/2	2
15	10831	WASHER, LOCK, INT. TOOTH #10	2
16	10711	VALVE, BALL 1/2 FPT	1
17	80021	CONN., SWIVEL FEM. 3/4 HOSE x 1/2 MPT (INCL. #18)	1
18	10020	WASHER, HOSE (INCL. w/ #17)	1
19	10734	ELBOW, STREET 1/4 NPT x 45° (BLACK)	1
20	86329	HOSE 3/8 ID x 19-1/4	1
21	50069	CLAMP, HOSE, SIZE M6, ADJ. TO 13/16	2
22	11544	BARB. PUSH-ON 3/8 HOSE x 1/4 FPT	1
23	11562	BARB, ELBOW 90°, 3/8 HOSE x 1/8 MPT	1
24		DGH-10 DIAMOND DISC (INCL. ITEM # 25)	1
	19165	GREEN (HARD BOND, 9 MATRIX)	
	19161	WHITE (MED. HARD BOND, 7 MATRIX)	
	19160	RED (MED. BOND, 5 MATRIX)	
	19162	ORANGE (SOFT BOND, 1 MATRIX)	
25	86108	SCREW, FLAT HEAD SKT. 3/8-24 x 3/4	4
26	86326	HEAD SUBASSEMBLY - SEE ILLUSTRATION #2	1
27	86304	HANDLE BAR	1
28	10608	GRIP, HAND 1" MODEL AT	2
29	10029	SCREW, CAP 3/8-24 x 1-3/4	4
30	10025	WASHER, FLAT 3/8	8
31	10004	NUT, LOCK 3/8-24	4
32	86306	AXLE SHAFT 3/4 x 17-1/2	1
33	79013	WHEEL 8 x 2-1/2 x 3/4" BRG.	2
34	10428	COLLAR, LOCKING 3/4" ID	2
35	10009	WASHER, FLAT 3/4	4
36	80022	SPACER, WHEEL 13/16" x 13/16"L	2
37	86305	FLIP-HOLDER, WHEEL AXLE (NEW STYLE)	2
38	10139	SCREW, SET 1/4-20 x 5/16	2
39	10321	SCREW, CAP 1/2-20 x 1-1/4	2
40	10312	WASHER, FLAT 1/2	2
41	10205	NUT, LOCK 1/2	2

ILLUSTRATION # 2: HEAD ASSEMBLY

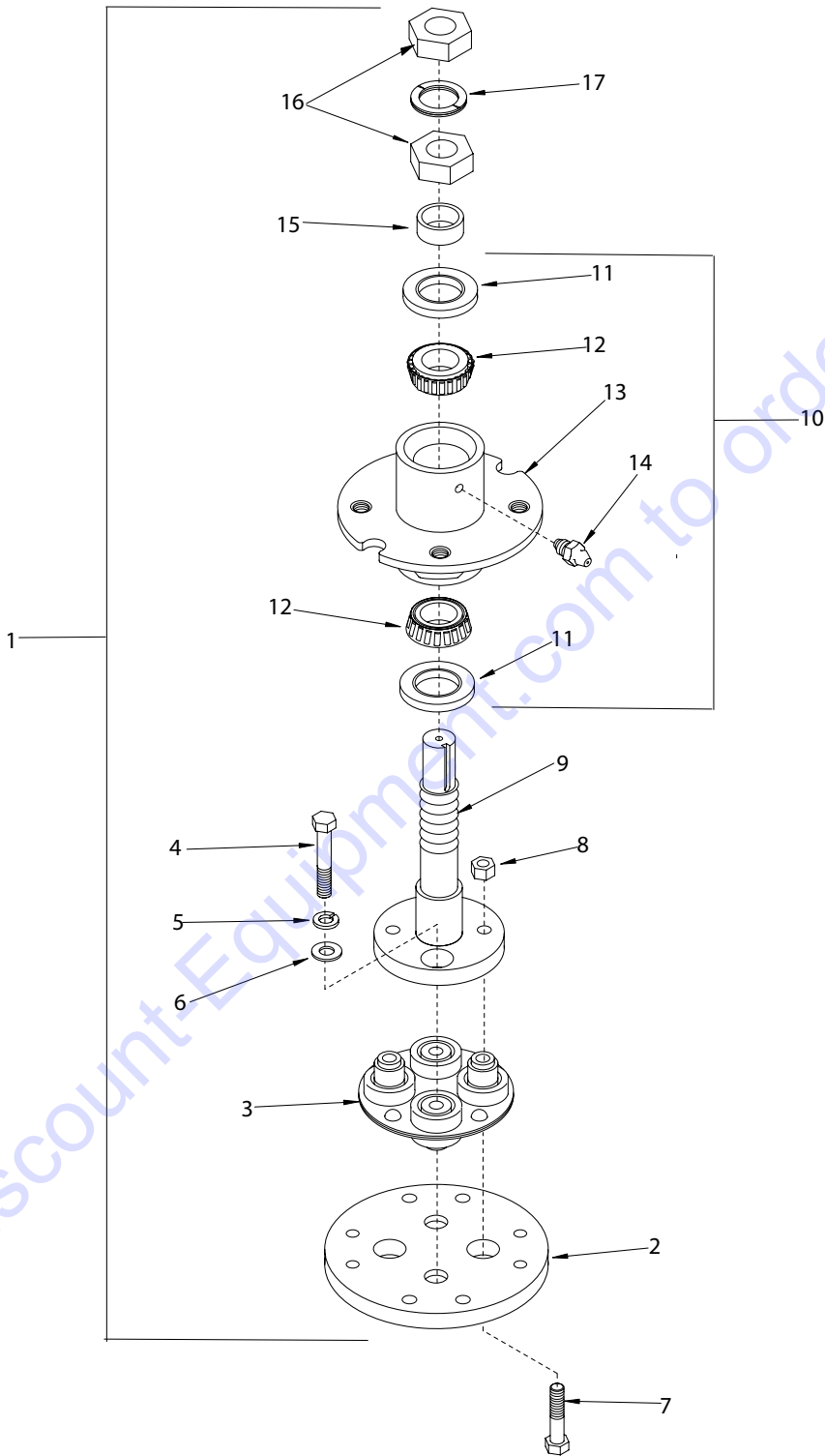

PARTS LISTING - ILLUSTRATION # 2: HEAD ASSEMBLY

ITEM #	PART #	DESCRIPTION	QTY.
1	86326	HEAD ASSEMBLY (INCLUDES ITEMS # 1-17)	
2	86309	DISC, DIAMOND HEAD MOUNTING	1
3	86017	COUPLING, MORFLEX 402	1
4	10030	SCREW, CAP 3/8-24 x 2 (USE RED LOCTITE)	2
5	10811	WASHER, LOCK 3/8	2
6	10025	WASHER, FLAT 3/8	2
7	10029	SCREW, CAP 3/8-24 x 2-1/4	2
8	10004	NUT, LOCK 3/8-24	2
9	86308	FLANGE w/ SHAFT, HEAD	1
10	86320A	HUB ASSY. w/ BRGS. & SEALS (INCLUDES ITEMS # 11-14)	
11	86322	SEAL, BEARING HUB 1-1/4"	2
12	86321	BEARING, TAPERED ROLLER 1"	2
13	86320H	HUB ONLY w/ RACES, 4 LUG/4" B.C.	1
14	10808	FITTING, GREASE 1/4-28 STRAIGHT	1
15	86319	SPACER, HUB BEARING	1
16	50019	NUT, JAM 1-14	2
17	86323	WASHER, NORD-LOCK 1"	1

ILLUSTRATION # 3 : ENGINE GROUPING

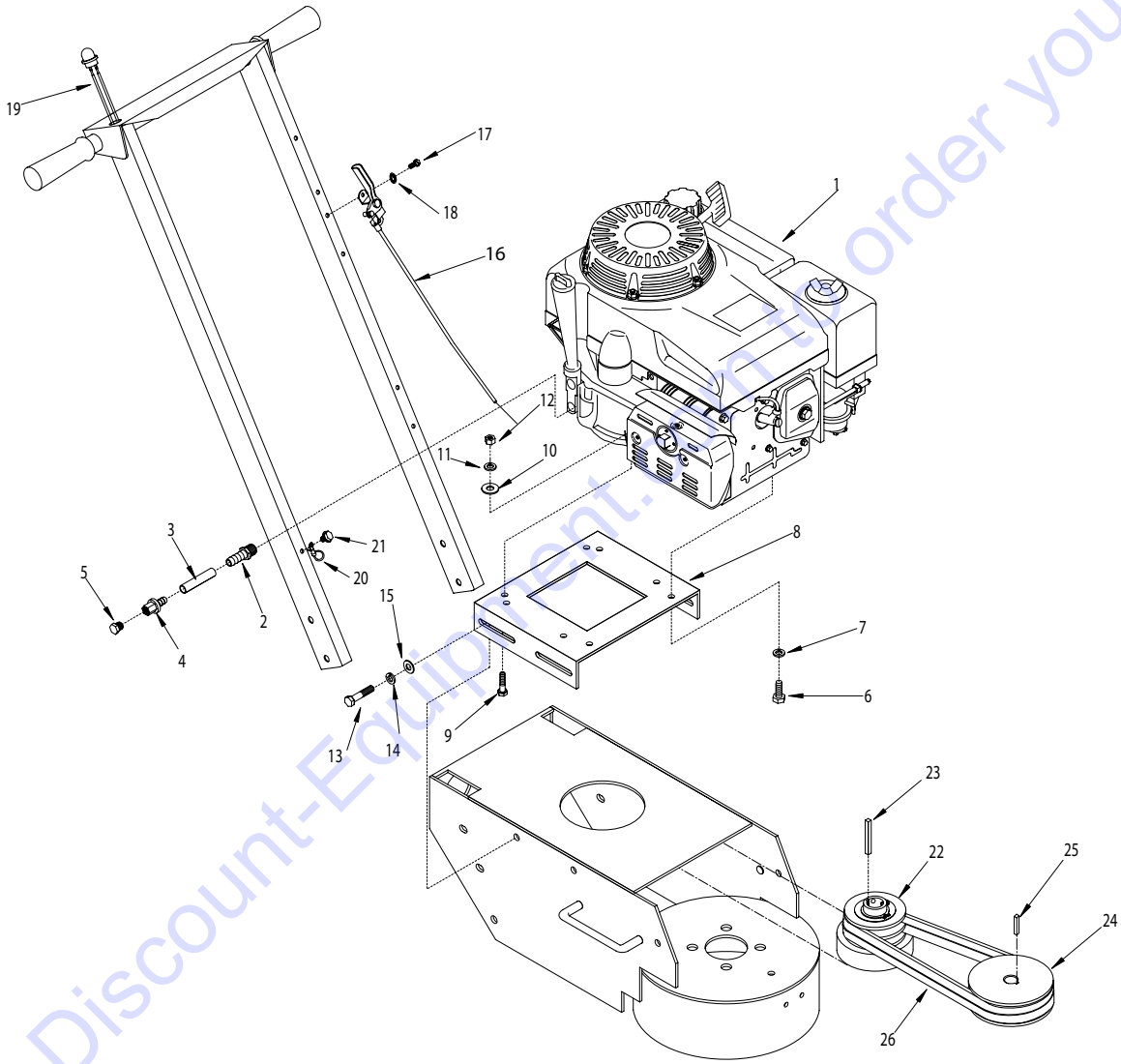

PARTS LISTING - ILLUSTRATION # 3 : ENGINE GROUPING

ITEM #	PART #	DESCRIPTION	QTY.
1	76004	ENGINE, HONDA 11HP GXV340 K2-DX3	1
2	11543	BARB, PUSH-ON 3/8 HOSE x 20mm x 1.50	1
3	56116	HOSE, PUSH-ON 3/8 ID x 3"L - BLACK	1
4	11544	BARB, PUSH-ON 3/8 HOSE x 1/4 FPT	1
5	10776	PIPE PLUG 1/4 NPT (BRASS)	1
6	10048	SCREW, CAP 5/16-24 x 3/4	2
7	10801	WASHER, LOCK 5/16	2
8	86311	MOUNT, ENGINE/MOTOR	1
9	10342	SCREW,CAP 5/16-18 x 1-1/2	2
10	10213	WASHER, FLAT 5/16	2
11	10801	WASHER, LOCK 5/16	2
12	10054	NUT 5/16-18	2
13	10021	SCREW, CAP 3/8-24 x 1"	4
14	10811	WASHER, LOCK 3/8	4
15	10025	WASHER, FLAT 3/8	4
16	40388	THROTTLE CABLE, LEVER-TYPE, 24" (TRIM 17")	1
17	10877	SCREW, CAP STSHW 10-24 x 1/2	2
18	10831	WASHER, LOCK, INT. TOOTH # 10	1
19	50010	SWITCH KIT, STOP BUTTON, 7/8" HOLE	1
20	50084	TERM. RING #10, 16-14 GA. INSULATED	1
21	10877	SCREW, CAP STSHW 10-24 x 1/2	1
22	76024	CLUTCH, CENTRIFUGAL 3.5 x 2GR. x 1	1
23	10071	KEY 1/4 SQ. x 2-1/2	1
24	86318	SHEAVE 5"OD x 2GR. x 7/8 BORE	1
25	50523	KEY 3/16 SQ. x 1-1/8	1
26	10035	BELT 5L-330	2

PARTS LISTING - ILLUSTRATION # 4 : PROPANE OPTION

ITEM #	PART #	DESCRIPTION	QTY.
1	15012	ENGINE, HONDA 11HP GXV-340 DAP2 PROPANE	1
2	15126	STARTER KIT, ELECTRIC 120 VOLT AC (INCLUDES EXTENSION CORD - NOT SHOWN)	1
3	86327	MOUNT, PROPANE TANK, TG-10	1
4	10029	SCREW, CAP 3/8-24 x 1-3/4	4
5	10025	WASHER, FLAT 3/8	8
6	10004	NUT, LOCK 3/8-24	4
7	77061	PROPANE TANK MOUNTING BRACKET TB-4	1
8	10802	BOLT, CARRIAGE 3/8-16 x 1	4
9	10025	WASHER, FLAT 3/8	4
10	10811	WASHER, LOCK 3/8	4
11	10404	NUT 3/8-16	4
12	15130	PROPANE TANK 20LB HORZ. w/ ACME VALVE	1
13	91122	DECAL, ARROW, RED, 3 x 3	1
14		SCREW w/ WASHER,CAP 1/4-20 x 5/8 (C/W VAPOR KIT)	4
15	15102	VAPOR KIT for HONDA GXV340-DAP2	1

ILLUSTRATION # 5 : ELECTRIC MOTOR GROUPING

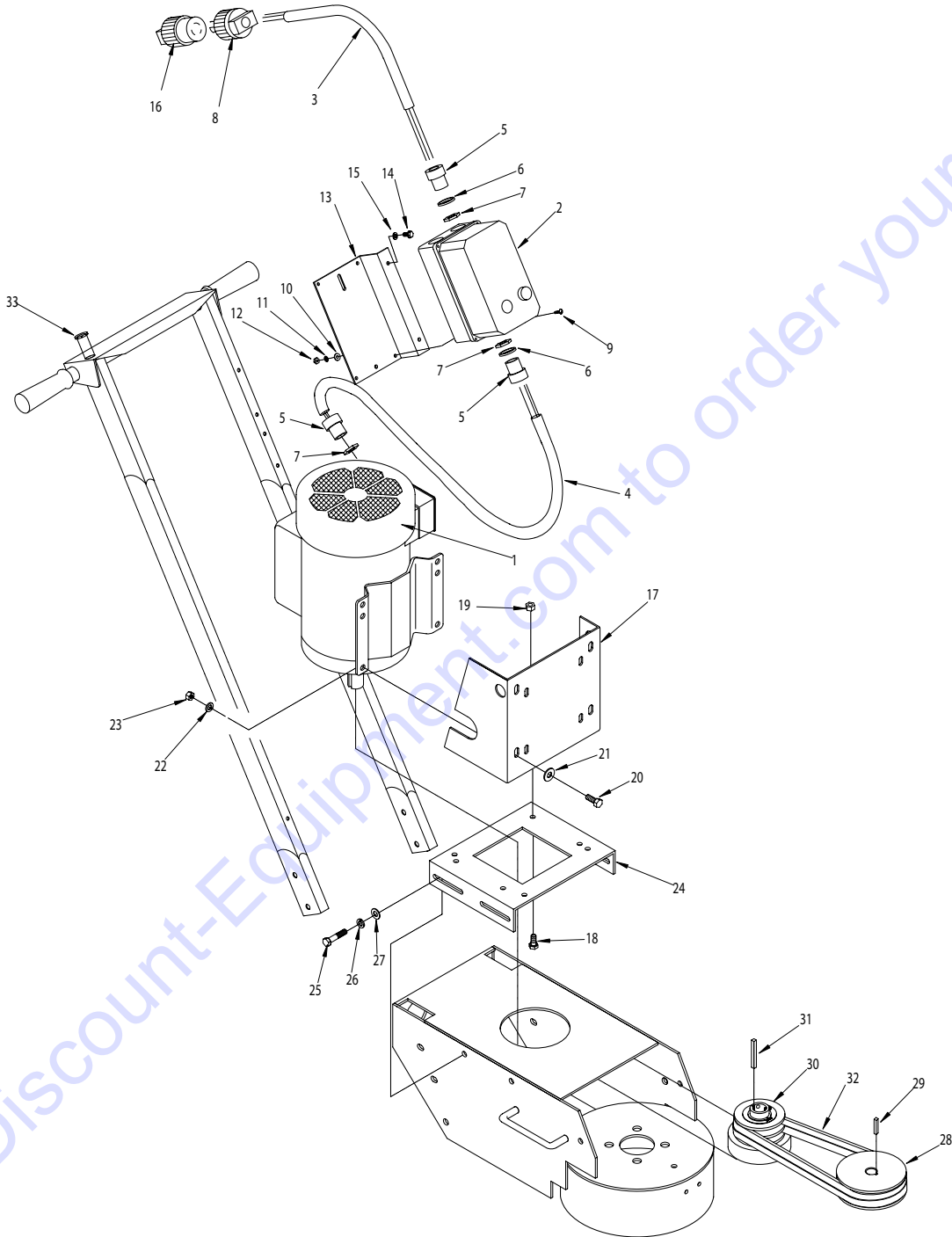

Go to Discount-Equipment.com to order your parts

PARTS LISTING - ILLUSTRATION # 5 : ELECTRIC MOTOR GROUPING			
ITEM #	PART #	DESCRIPTION	QTY.
1		MOTOR, BALDOR 3450 RPM	1
	81026	5.0 HP - 1 PHASE - 60 Hz - 230V 3450 RPM	
	81022	5.0 HP - 3 PHASE - 60Hz - 230V/460V 3450 RPM	
2		STARTER, LOVATO	1
	16410	1 PH - 60Hz - 230V (11-M1-BRF-P30-26-23060)	
	16405	3 PH - 60Hz - 230V (11-M1-BRF-P23-23-23060)	
	16406	3 PH - 60Hz - 460V (11-M1-BRF-P14-10-46060)	
3		WIRE HARNESS, STARTER / PLUG	1
	86026	10/3" x 24" LOA (1 PHASE UNITS)	
	86022	12/4" x 24" LOA (3 PHASE UNITS)	
4		WIRE HARNESS, STARTER / MOTOR	1
	86331	10/3" x 36" LOA (1 PHASE UNITS)	
	86332	12/4" x 36" LOA (3 PHASE UNITS)	
5	10605	CONNECTOR, STRAIN RELIEF 3/4 NPT x .650 - .750 RANGE	3
6	77081	WASHER, FLAT, SWITCH BOX OUTER	2
7	10740	CONDUIT LOCK NUT 3/4 NP	3
8	40037	PLUG, LOCKING 20A/250V (SEE NOTE)	1
9	10362	SCREW, MACHINE 8-32 x 3/4	4
10	12112	WASHER, RIVET #9 5/32 x 7/16 x 3/64	4
11	10461	WASHER, LOCK, INT. TOOTH #8	4
12	10462	NUT 8-32	4
13	86027	MOUNTING BRACKET, LOVATO STARTER	1
14	10846	SCREW, CAP STSHW 1/4-20 x 1/2	2
15	10038	WASHER, LOCK 1/4	2
16	40000	PLUG CONNECTOR, LOCKING 20A/250V (SEE NOTE)	1
17	86312	MOUNT, MOTOR	1
18	10907	SCREW, CAP 3/8-16 x 3/4	4
19	10810	NUT, LOCK 3/8-16	4
20	10021	SCREW, CAP 3/8-24 x 1	2
21	10025	WASHER, FLAT 3/8	4
22	10811	WASHER, LOCK 3/8	4
23	10014	NUT 3/8-24	4
24	86311	ENGINE/MOTOR MOUNT	1
25	10021	SCREW, CAP 3/8-24 x 1	4
26	10811	WASHER, LOCK 3/8	4
27	10025	WASHER, FLAT 3/8	4
28	86318	SHEAVE 5"OD x 2Gr.B x 7/8 BORE	1
29	50523	KEY 3/16" SQ. x 1-1/8	1
30	76024	CLUTCH, CENTRIFUGAL 3.5 x 2GR. x 1	1
31	10071	KEY 1/4" SQ. x 2-1/2	1
32	10221	BELT 5L - 340 (REFER TO SERIAL NO. PLATE)	1
33	10005	PLUG, HOLE 7/8" (CHROME)	1

NOTE: PLUG CONNECTOR (ITEMS # 8 & 16) ARE NOT SUPPLIED ON 3 PHASE UNITS.

ILLUSTRATION # 6: OPTIONAL BALL CASTER DEPTH STOP KIT & WEIGHT

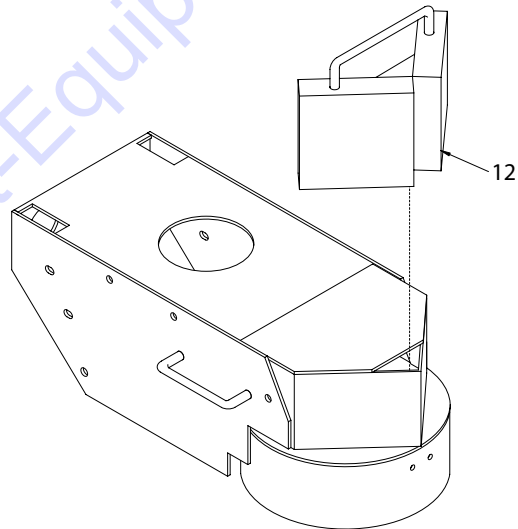
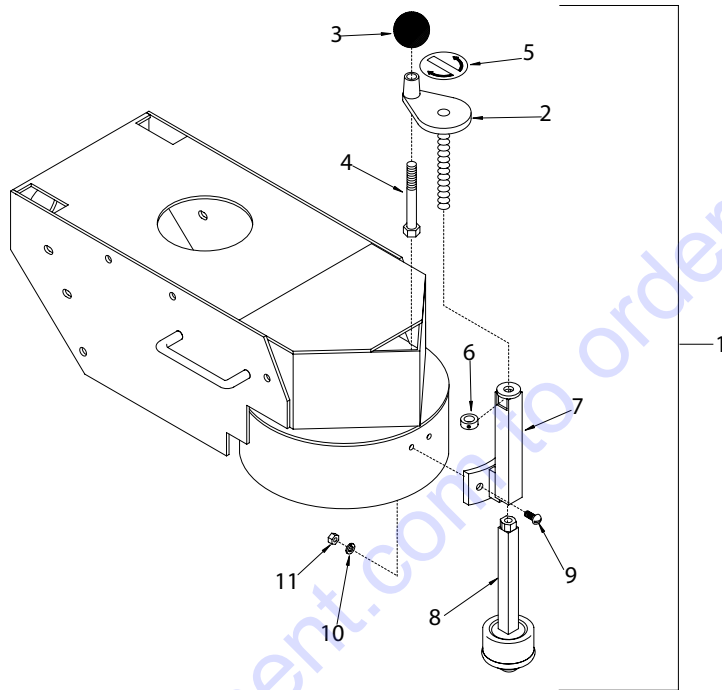

PARTS LISTING - ILLUSTRATION # 6: OPTIONAL BALL CASTER DEPTH STOP KIT & WEIGHT			
ITEM#	PART#	DESCRIPTION	QTY.
1	86330	BALL CASTER DEPTH STOP KIT (INCLUDES ITEMS # 2-11)	
2	86313	HANDWHEEL, SMALL w/ ROD	1
3	10104	KNOB, BALL 1-7/8 DIA. w/ 1/2-13 THD., BLK.	1
4	81001	SCREW, CAP 1/2-13 x 4	1
5	80007	DECAL, CUT-CONTROL, DN/UP (SMALL)	1
6	86316	COLLAR, LOCKING 1/2"	1
7	86314	SUPPORT, DEPTH STOP	1
8	86315	BALL CASTER	1
9	10818	BOLT, CARRIAGE 5/16-18 x 3/4	2
10	10801	WASHER, LOCK 5/16	2
11	10054	NUT 5/16-18	2
12	86340	WEIGHT, 30 LB.	1

PARTS FINDER

**Search Website
by Part Number**



**Search Manual
Library For Parts
Manual & Lookup Part
Numbers – Purchase
or Request Quote**

Search Manuals

Enter your information to help us find the right parts manual for your equipment.

* Brand:

* Model:

* Serial:

* Part Number:

SEARCH

**Can't Find Part or
Manual? Request Help
by Manufacturer,
Model & Description**

Parts Order Form

Please fill in the following information to help us find the right part for your equipment.

MANUFACTURER:

MODEL:

DESCRIPTION:

DATE:

TIME:

PHONE:

EMAIL:

ADDRESS:

CITY:

STATE:

ZIP:

SEARCH

Discount-Equipment.com is your online resource for quality parts & equipment.

Florida: **561-964-4949** Outside Florida TOLL FREE: **877-690-3101**

Need parts?

Click on this link: <http://www.discount-equipment.com/category/5443-parts/> and choose one of the options to help get the right parts and equipment you are looking for. Please have the machine model and serial number available in order to help us get you the correct parts. If you don't find the part on the website or on one of the online manuals, please fill out the request form and one of our experienced staff members will get back to you with a quote for the right part that your machine needs.

We sell worldwide for the brands: Genie, Terex, JLG, MultiQuip, Mikasa, Essick, Whiteman, Mayco, Toro Stone, Diamond Products, Generac Magnum, Airman, Haulotte, Barreto, Power Blanket, Nifty Lift, Atlas Copco, Chicago Pneumatic, Allmand, Miller Curber, Skyjack, Lull, Skytrak, Tsurumi, Husquvarna Target, Stow, Wacker, Sakai, Mi-T-M, Sullair, Basic, Dynapac, MBW, Weber, Bartell, Bennar Newman, Haulotte, Ditch Runner, Menegotti, Morrison, Contec, Buddy, Crown, Edco, Wyco, Bomag, Laymor, EZ Trench, Bil-Jax, F.S. Curtis, Gehl Pavers, Heli, Honda, ICS/PowerGrit, IHI, Partner, Imer, Clipper, MMD, Koshin, Rice, CH&E, General Equipment, Amida, Coleman, NAC, Gradall, Square Shooter, Kent, Stanley, Tamco, Toku, Hatz, Kohler, Robin, Wisconsin, Northrock, Oztec, Toker TK, Rol-Air, APT, Wylie, Ingersoll Rand / Doosan, Innovatech, Con X, Ammann, Mecalac, Makinex, Smith Surface Prep, Small Line, Wanco, Yanmar