



Operator's Instruction Manual

TG-10



TURBO GRINDERS

Available in Gasoline, Propane and Electric



EQUIPMENT DEVELOPMENT CO., INC.

TO PURCHASE THIS PRODUCT PLEASE CONTACT US



**Equipment Financing and
Extended Warranties Available**



**Discount-Equipment.com is your online resource for
commercial and industrial quality parts and equipment sales.**

561-964-4949

visit us on line @ www.discount-equipment.com

Select an option below to find your Equipment

Search by Manufacturer

Search by Product Type

Request a Quote

We sell worldwide for the brands: Genie, Terex, JLG, MultiQuip, Mikasa, Essick, Whiteman, Mayco, Toro Stone, Diamond Products, Generac Magnum, Airman, Haulotte, Barreto, Power Blanket, Nifty Lift, Atlas Copco, Chicago Pneumatic, Allmand, Miller Curber, Skyjack, Lull, Skytrak, Tsurumi, Husquvarna Target, Stow, Wacker, Sakai, Mi-T-M, Sullair, Basic, Dynapac, MBW, Weber, Bartell, Bennar Newman, Haulotte, Ditch Runner, Menegotti, Morrison, Contec, Buddy, Crown, Edco, Wyco, Bomag, Laymor, EZ Trench, Bil-Jax, F.S. Curtis, Gehl Pavers, Heli, Honda, ICS/PowerGrit, IHI, Partner, Imer, Clipper, MMD, Koshin, Rice, CH&E, General Equipment, Amida, Coleman, NAC, Gradall, Square Shooter, Kent, Stanley, Tamco, Toku, Hatz, Kohler, Robin, Wisconsin, Northrock, Oztec, Toker TK, Rol-Air, APT, Wylie, Ingersoll Rand / Doosan, Innovatech, Con X, Ammann, Mecalac, Makinex, Smith Surface Prep, Small Line, Wanco, Yanmar



READ AND UNDERSTAND THE OPERATORS INSTRUCTION MANUAL *THOROUGHLY*

BEFORE ATTEMPTING TO OPERATE THIS EQUIPMENT.



Death or serious injury could occur if this machine is used improperly.



SAFETY MESSAGES

• Safety Instructions are preceded by a graphic alert symbol of DANGER, WARNING, or CAUTION.



Indicates an imminent hazard which, if not avoided, will result in death or serious injury.



Indicates an imminent hazard which, if not avoided, can result in death or serious injury.



Indicates hazards which, if not avoided, could result in serious injury and or damage to the equipment.

GASOLINE/PROPANE POWERED EQUIPMENT



• Engine exhaust from this product contains chemicals known to the State of California to cause cancer, birth defects or other reproductive

harm.



Gasoline is extremely flammable and poisonous. It should only be dispensed in well ventilated areas, and with a cool engine.

- Small gasoline engines produce high concentrations of carbon monoxide (CO) example: a 5 HP 4 cycle engine operation in an enclosed 100,000 cu. ft. area with only one change of air per hour is capable of providing deadly concentrations of CO in less than fifteen minutes. Five changes of air in the same area will produce noxious fumes in less than 30 minutes. Gasoline or propane powered equipment should not be used in enclosed or partially enclosed areas. Symptoms of CO poisoning include, headache, nausea, weakness, dizziness, visual problems and loss of consciousness. If symptoms occur - get into fresh air and seek medical attention immediately.

ELECTRICAL POWERED EQUIPMENT



Extreme care must be taken when operating electric models with water present: Ensure power cord is properly grounded, is attached to a Ground-Fault-Interrupter (GFI) outlet, and is undamaged.

- Check all electrical cables - be sure connections are tight and cable is continuous and in good condition. Be sure cable is correctly rated for both the operating current and voltage of this equipment.
- Improper connection of the equipment-grounding conductor can result in a risk of electric shock. Check with qualified electrician or service person if there is any doubt as to whether the outlet is properly grounded. Adhere to all local codes and ordinances.
- **NOTE:** In the event of a malfunction or breakdown, grounding provides a path of least resistance for the electric current to dissipate. The machine is equipped with a grounded plug and must be connected to an outlet that is properly installed and properly grounded. DO NOT modify the plug provided on the motor. If the plug does not fit the outlet have a qualified electrician install the proper receptacle.
- Switch motor OFF **before** disconnecting power.

- Do not disconnect power by pulling cord. To disconnect, grasp the plug, not the cord.
- Unplug power cord at the machine when not in use and before servicing.

GENERAL INSTRUCTIONS

- Equipment should only be operated by trained personnel in good physical condition and mental health (not fatigued). The operator and maintenance personnel must be physically able to handle the bulk weight and power of this equipment.
- This is a one person tool. Maintain a safe operating distance to other personnel. It is the **operators' responsibility** to keep other people (workers, pedestrians, bystanders, etc.) away during operation. Block off the work area in all directions with roping, safety netting, etc. for a safe distance. Failure to do so may result in others being injured by flying debris or exposing them to harmful dust and noise.
- This equipment is intended for commercial use only.
- For the operator's safety and the safety of others, always keep all guards in place during operation.
- Never let equipment run unattended.



- Personal Protection Equipment and proper safety attire must be worn when operating this machinery. The operator must wear approved safety equipment appropriate for the job such as hard hat and safety shoes when conditions require. Hearing protection **MUST** be used (operational noise levels of this equipment may exceed 85db). Eye protection **MUST** be worn at all times.



Keep body parts and loose clothing away from moving parts. Failure to do so could result in dismemberment or death.

- Do not modify the machine.
- Stop motor/engine when adjusting or servicing this equipment. Maintain a safe operating distance from flammable materials. Sparks from the cutting-action of this machine can ignite flammable materials or vapors.



DUST WARNING



Some dust created by power sanding, sawing, grinding, drilling, and other construction activities contains chemicals known to cause cancer, birth defects, or other reproductive harm. Some examples of these chemicals are:

- Lead from lead-based paints, and
- Crystalline silica from bricks and concrete and other masonry products.

Your risk of exposure to these chemicals varies depending on how often you do this type of work. To reduce your risk: work in a well ventilated area, use a dust control system, such as an industrial-style vacuum, and wear approved personal safety equipment, such as a dust/particle respirator designed to filter out microscopic particles.



Operator's Instruction Manual

TG-10 TURBO GRINDERS

Table of Contents

Safety Information 2

Table of Contents and Specifications 3

Safety Guidelines 4

Operating Instructions 5-8

Quick Change Multi-Accessory Disc Accessories 9

Maintenance 10-11

Machine Safety Symbol Label Reference 12,13

Maintenance Schedule 14

Dust and Crystalline Silica Warning 15

Notes 16-18

Limited Equipment Warranty 19



NOTE: Due to improvements your machine may not appear the same as the pictures in this manual.

Figure 1

Specifications & Dimensions are for reference only and subject to change.			
Model	TG10-5B	TG10-11H	TG10-13P
Length (L)	41"/104cm	41"/104cm	41"/104cm
Width (W)	24"/61cm	24"/61cm	24"/61cm
Height (H)	38"/97cm	38"/97cm	38"/97cm
Total Weight	175 lbs.	180 lbs.	220 lbs.
Weights include 10" Diamond Disc (20 Segments)			



Read and understand all operating instructions
before operating this equipment.



Death or serious injury can result if this machine is used improperly.



Safety Guidelines



Eye and ear protection must be worn at all times while the grinder is in use. During normal operation, sound pressure levels may exceed 85dBA. Use only ANSI approved safety glasses to help prevent eye injury. Everyday eyeglasses have only impact resistant lenses; they are NOT safety glasses.



Operator must wear appropriate clothing and footwear. Do not wear loose clothing or jewelry that can get tangled in moving parts. Footwear should provide sure footing and protection.



Materials being removed can be toxic or hazardous. A breathing respirator is required to help protect the operator from inhaling the airborne material when operating this machine.

- Inspect the work surface for cracks, uneven joints and foreign objects such as nails, screws and pipes. Damage to the disc and/or equipment may result which can also cause serious injury to the operator. Hazardous areas should be properly identified and clearly marked.
- The TG-10 is designed to be controlled by a single operator .
- Inspect the discs carefully before installing. Do not use **any** questionable disc since serious personal injury and/ or damage to property can result.
- Never operate this grinder while under the influence of drugs, alcohol or when taking medications that impair the senses or reactions, or when excessively tired or under stress.
- Be sure decals on the machine can be clearly read and understood. Replace worn or missing decals immediately,

Safety warnings and guidelines do not by themselves eliminate danger. They are not given as substitutes for proper accident prevention procedures and good judgement.



Operating Instructions



Exhaust from this engine contains Carbon Monoxide, an invisible, odorless gas that can kill. In addition, it contains chemicals known, in certain quantities, to cause cancer, birth defects or other reproductive harm.

Before Operating:

- **Visually inspect machine:**

- Verify all guards are in place and fasteners are tight.
- Check engine oil level (gasoline/propane models).
- Inspect power cord for damage and check for proper grounding (electric models).

- **Inspect disc assembly:**

- Check discs for damage or wear.
- Check mounting hardware.
- Check belt tension after first 4 hours of use with factory new equipment or after installing new belts.

- **Inspect the work area:**

Inspect work area carefully before starting to grind. EDCO will not be held responsible for damage to the discs caused by striking protruding slab inserts, nails, screws, pipe extensions, machinery bases, or other objects that transmit sudden shocks.

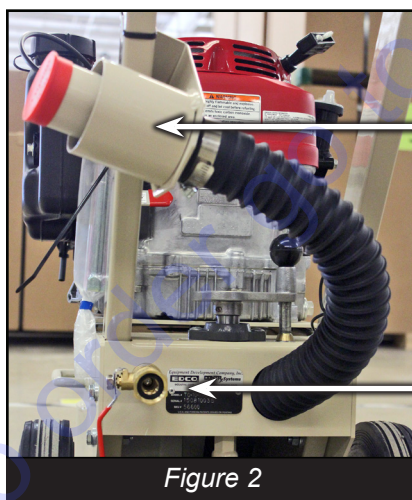

Figure 2

- **If dry grinding:**

- Hook up heavy-duty vacuum.

- **NOTE:**

Do not use dry vacuum when wet grinding.

- **If wet grinding:**

- Attach hose to water supply.

Important Reminder!

A water mist system or an industrial vacuum **must** be used while operating this equipment and the operator must wear a respirator. Failure to comply could lead to serious illness and possible death.

Safety warnings and guidelines do not by themselves eliminate danger.

They are not given as substitutes for proper accident prevention and good judgement.



Gasoline Models: (11 HP Honda Engine)

To Start the Engine:

- Tilt the machine back slightly to allow the disc to clear the slab surface.
- Start the engine according to the directions in the engine manufacturer's Owner's Manual.

NOTE: If during operation refueling becomes necessary, allow the engine to cool down. NEVER refuel a hot engine.

To Stop the Gasoline Model:

- Tilt the machine back slightly to allow the disc to clear the slab surface.
- Turn the engine off.

To STOP engine - Press Emergency Stop Switch to OFF position

Press to ON position when re-starting Engine (*Figure 3*)

Propane Models: (13 HP Honda Engine with 110V Key Start)

DANGER

Propane is extremely flammable. VAPOR ONLY

To Start the Engine:

- Ensure that tank is positioned properly (arrow  up).
- Turn on main valve on tank & Emergency Stop switch on handle.
- If you detect a gas odor immediately shut off engine and consult your operator's manual.
- Turn key to START
- Open throttle completely until engine runs smooth.
- Adjust throttle back to idle and sit machine back on surface.
- Increase speed to operating position (**MAXIMUM 3400RPM's**) & begin grinding. Refer to tachometer (*Figure 3.1*) for operating speed.

To Stop the Propane Model:

NOTE: If engine stops abruptly (uncontrolled stop) or using E-STOP wait several minutes for propane gas to clear the fuel system and carburetor before trying to re-start.

- Tilt machine back slightly to allow the disc to clear the slab surface.
- If stopping for the day close valve and allow machine to purge propane from system.
- Turn key and emergency switch off.
- Otherwise just turn key off.

Electric Models: (5 HP Baldor. Available in 1 Phase or 3 Phase)

WARNING

Electric units must be connected to a properly grounded electrical system using an approved electrical cable.

To Start the Motor:

- Tilt the machine back slightly, just enough for the disc to clear the slab surface.
- On 5 HP, single phase turn to the ON position. On the 5 HP, three phase, press the ON button.
- Be sure to check motor for correct rotation.
- Gently set the machine back down until the disc touches the slab surface and begin moving the machine.



Figure 3

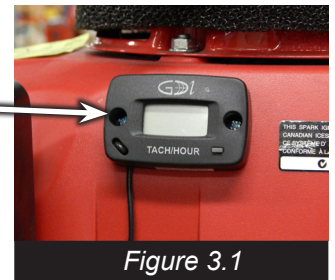

Figure 3.1



To Stop the Electric Model:

- Tilt the machine to allow the disc to clear the slab surface.
- Turn rotary switch to the OFF position or press OFF button on the starter box.

Wet Grinding:

- In the wet grinding stage - water is fed from a standard garden hose into a ball valve cut off, then into a nozzle that sprays over the disc assembly. (Figure 4)
Use the ball valve to regulate the flow of water to the disc.



Only use enough water flow to reduce dust. Excess water flow will create clean up problems and could cause a hazardous walking area.



Always use dust control when using this product, vacuum or water mist.

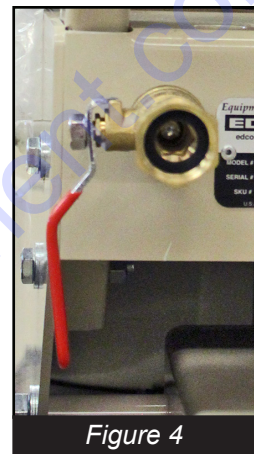

Figure 4

Dry Grinding:



Dry Grinding creates a large volume of airborne dust. For health reasons, the operator should wear an applicable respirator. The dust may contain chemicals known to cause serious illnesses, including Silicosis - a fatal disease of the lungs. Check the chemical properties of the material to be removed and follow all EPA/OSHA regulations.

Controlling the Grind:

- Grinding discs are *extremely* aggressive. It is important to **KEEP THE GRINDER MOVING IN A SIDE-TO-SIDE MOTION**, do not let the grinder stay in one spot, even for a few seconds, or the surface will be damaged. When grinding is completed, tilt the machine back and shut off the power.
- To achieve a smooth "polished" surface, complete the grinding operation with an EDCO dual disc unit using grinding stones or dyma-serts.
- To remove a light coating, move the grinder quickly. For heavier removal, move the grinder more slowly.
- Keep the grinding disc flat - do not attempt to grind against vertical surfaces. Be sure the machine is in the correct operating position. (See Figure 5)



Figure 5

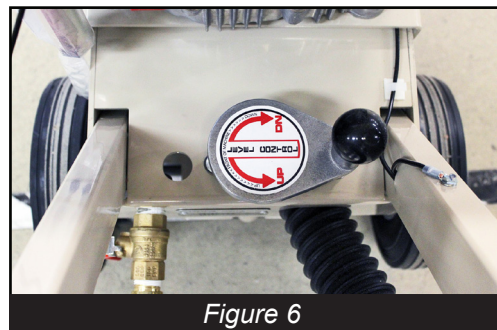

Figure 6



Comments in paragraph below are in reference to this level adjustment control (Figure 6).

NOTE: Ensure when leveling the machine as explained below that it (the machine) is sitting on a FLAT LEVEL surface otherwise adjustments may not be correct for the surface being worked on.

If rear of grinding disc is higher (not touching the work surface) than the front of the disc (touching the work surface) turn this control (Figure 7) counter clockwise until disc sits level (flat) on the work surface.

If front of grinding disc is higher (not touching the work surface) than the rear of the disc (touching the work surface) turn this control (Figure 7) clockwise until disc sits level (flat) on the work surface.

Do a light touch pass after each adjustment looking for a complete circle from the disc.

Discs:

- Inspect the disc (Figure 7) periodically to determine it's wear characteristics, if signs of uneven wear appear the cause should be determined and corrected. If repairs are needed contact Discount-equipment.
- **Rigid Head** can be used on uneven expansion joints, high spots, joint curls and bridge decks, removing coatings and grinding rough concrete surfaces. Use with a vacuum or water for dust control but not the same time. (Figure 8)
- **Flex Head** can be used preparing a smooth, flat floor to receive a new coating, removing coatings, grind rough concrete surfaces. Can be used with a vacuum or water for dust control but not the same time. (Figure 9)



Figure 7
Disc shown is for reference only.

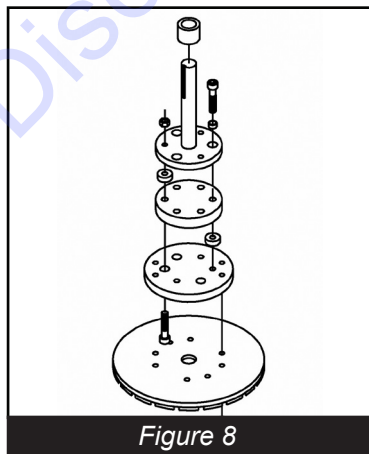

Figure 8
Standard RIGID HEAD

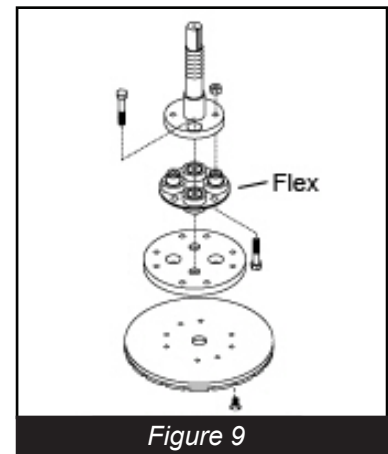

Figure 9
Optional FLEX HEAD

- This unit comes standard with a 10" Diamond Disc. Optional 6 pocket Mult-Accessory disc can be supplied. This allows for the use of low profile grinding tools.
NOTE: The low profile tooling can be used in either a 6 tool set up or a 3 tool set up. If only using 3 tools make sure they are evenly spaced on the disc.
- Each new machine is shipped with a RIGID HEAD (FLEX HEAD OPTIONAL) 10"/255 mm factory balanced disk. It is important to maintain the coupling to which the disk is attached. A worn coupling, damaged bearings or a bent shaft will cause the grinding discs to wear unevenly. (Figure 8 rigid head assembly & 9 flex head assembly.) It is important to note FLEX HEAD for smooth flat surfaces, RIGID HEAD for buckled, bumpy or rough surfaces.



FOR USE WITH QUICK-CHANGE MULTI-ACCESSORY DISC



DOUBLE DIAMOND DOTS: General Purpose Grind - Removes general purpose epoxy, mastics, thinsets, water-proofing coatings and more.



SINGLE DIAMOND DOTS: Aggressive Grind - Grinds and removes thick epoxies, weather-proofing membrane and other coatings.

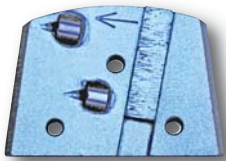

PCD ACCESSORY: Extremely Aggressive Removal - Digs through industrial strength coverings, water-proofing membranes, thick epoxies and much more - *Leaves a textured concrete surface.*



MAGNA-BLADE: Magna-Blades use carbide tipped blocks to strip away coatings and clean floors without grinding into the concrete. The replaceable multi-sided tungsten carbide can be rotated for maximum use.



Maintenance

Follow the engine manufacturer's guidelines for regular maintenance.

WARNING

Disconnect spark plug lead (*Figure 10*) before performing any maintenance on this machine! Or on the electric model, unplug the electric cord at the machine (instead of at the wall) to assure the machine will remain un-plugged while you are working on it.

Inspect Every 8 Hours:

- Inspect the disc mounting screws. (*Figure 11*) The constant vibration and heat generated, especially when grinding dry, could cause the screws to loosen and the disc to become off balance.

After every use:

- Inspect for lash in head (Does head move up/down)? (*Figure 12*). Verify that jam nuts, items 8 on page 10 in Parts Breakdown are tight and there isn't any play. Allowing these nuts to remain loose can damage the head assembly.
- If movement is noticed, STOP. Damage to head assembly may occur. In order to tighten these nuts the sheave under the hood must be removed. Bottom nut should be tightened and then backed off until head turns freely. Then top nut should be tightened down and jammed using two wrenches turning in opposite directions. After tightening make sure head still turns freely.

Lubricate Weekly:

- Bearings (*Figure 13*) must be lubricated weekly with Lubriplate 930-AA High Temp Grease or equivalent.
- Access fitting through opening on hood.

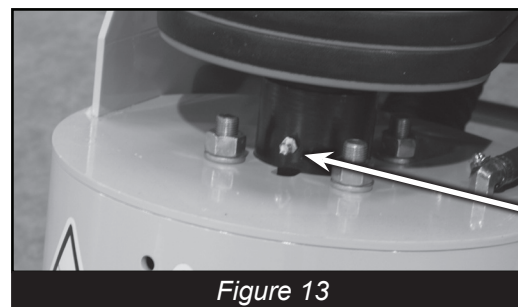
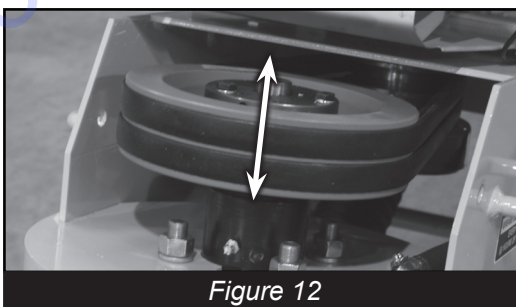
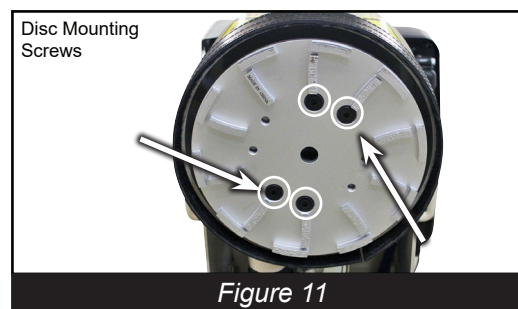
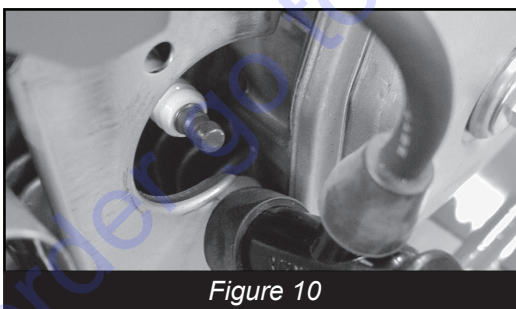



Maintenance

Belts:

To remove/replace belts:

- Remove belt cover to expose belts. (Figure 14)
- Loosen engine/motor mounting bolts (Figure 15) on both sides of the TG-10 and slide engine forward to allow belts to slide off.
- **Replace worn belts with a complete set of new belts** - even if only one belt is showing wear.
- Slide engine back in place until belts are tight and retighten engine mounting bolts.
- Reinstall belt cover and tighten hardware.
- After four hours of use, retighten belts.

Engine Air Filter:

Inspect the air filters (Figure 16) for excess dust, dirt or damage before the engine is operated. More often if operating in a dusty environment.

Operating the engine with a damaged or dirty air filter, or without an air filter, will allow dirt to enter the engine causing rapid engine wear which would not be covered under the engine manufacturer's warranty.

Follow the engine manufacturer's procedures for keeping the filters in good condition.

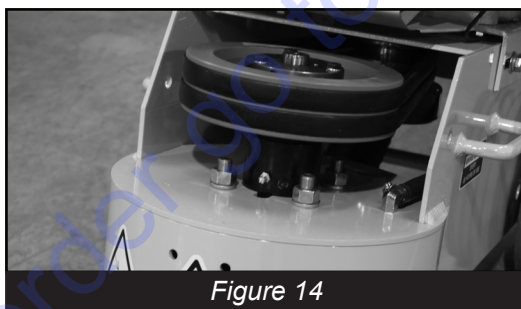

Figure 14

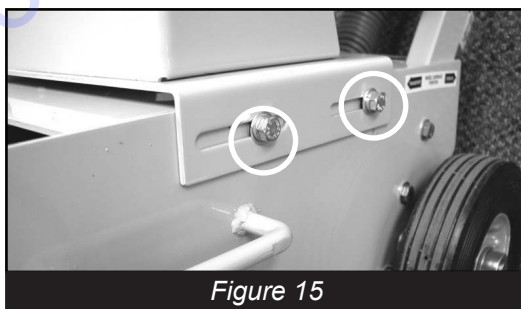

Figure 15

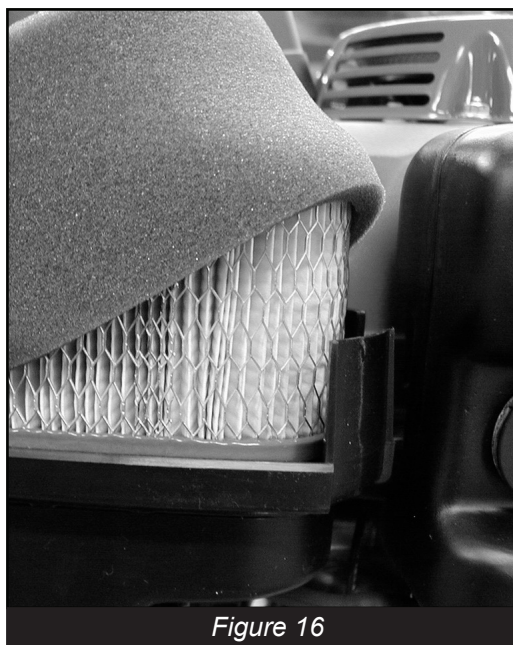

Figure 16



MACHINE SAFETY SYMBOL LABEL REFERENCE



This symbol means that the Operator's, owners, instruction and/or manufacturer(s) manuals must be read and understood before operating or attempting to operate this electrical, gasoline, diesel or propane powered equipment, failure to do so can result in personal injury and possible death.



This symbol means that proper eye protection must be worn/used during the operation of this equipment. There is a potential risk of operator eye damage, injury or loss of sight. This also applies to any personnel standing nearby observing the operation of this equipment.



This symbol means that proper ear protection should be worn/used during the operation of this equipment. There is a potential risk of operator hearing damage, injury or loss of hearing which will increase based on the length of exposure. This also applies to any personnel standing nearby observing the operation of this equipment.



This symbol means that proper head protection should be worn/used during the operation of this equipment there is a potential risk of operator head injury from foreign or loose objects the equipment might come in contact with during operation. This also applies to any personnel standing nearby or observing the operation of this equipment.



This symbol means that proper breathing protection or engineering controls must be worn/used during the operation of this equipment there is a potential risk of operator lung damage. Repeated and/or substantial inhalation of airborne crystalline silica can cause serious or fatal respiratory diseases, including silicosis. In addition, to California and some other authorities have listed respirable crystalline silica as a substance known to cause cancer. When grinding/cutting/drilling such materials, always follow local respiratory precautions. This also applies to any personnel standing nearby or observing the operation of this equipment.



This symbol denotes the lifting point and means that if lifting of this equipment is necessary use a lifting device that is designed to accommodate or exceed the weight of this machine. Check the Operator's manual for specifications. Using a device that is not designed to accommodate or exceed the weight of this machine could result in damage to the machine and personal injury. Do not lift equipment over people because death or serious injury could result.



This symbol means do not insert fingers/digits under any edge of the belt cover while the engine/motor on the machine is running because personal injury and loss of fingers/digits may result.



This GHS pictogram identifies that the chemicals contained present serious health hazards.



MACHINE SAFETY SYMBOL LABEL REFERENCE



This symbol means that the guards must remain in place while the engine/motor on the machine is running because death or personal injury may result.



This symbol means that there are moving parts and if feet/fingers/digits are inserted under any edge of the cutter/grinder/saw cover while the engine/motor on the machine is running that personal injury and loss of foot/fingers/digits may result.



This symbol means the surface is HOT and that if fingers/digits/hands or any bare or unprotected skin comes in contact with this surface or hot accessory, possible serious burns and personal injury may result.



This symbol means that potential hazardous voltages are present and the equipment must be properly grounded and extreme caution should be taken. If for any reason maintenance or repair is needed, insure that voltage(s) are disconnected at the machine and the source unless (be cautious) voltage needs to be present to troubleshoot the problem, then only qualified personal should work on "live" systems.



This symbol means that the machine is heavy if the machine needs to be lifted onto or off of a truck, loading dock etc. that proper technique or heavy duty lifting device should be used, personal injury could result.



This symbol means that dangerous chemicals, gases, dust particles and/or fumes are present including carbon monoxide. Proper ventilation must be maintained. Do not use gasoline/diesel/propane powered equipment indoors.



This symbol means that there are sharp components and if feet/fingers/digits come in contact personal injury or death could result.



This symbol means hazardous pressures are present. Caution should be exercised to prevent personal injury or damage to equipment. Face, eye and head protection should be used.



This symbol means explosive and hazardous vapors are present. Caution should be exercised to prevent personal injury to face and eyes. Breathing and personal protection should be used when servicing.



Read and follow the engine manufacturer's maintenance schedule.



Repairs are to be done by authorized EDCO Dealers only.

Maintenance Schedule

	Before Operation	After First 4 Hours	Every 8 Hours	Weekly	As Necessary
Inspect/tighten Jam nuts on head assy.				X	
Inspect Entire Machine	X				
* Check Oil & Fuel Levels	X				
* Check Air Filter (Clean if Necessary)	X				
* Inspect Propane Connections	X				
Inspect Disc	X				
Inspect Belt Tension		X			X
Lubricate Shaft Bearings				X	
Inspect/Tighten Disc Mounting Screws			X		X
Adjust Wheel Height					X
* Inspect Vacuum (empty bins, etc.)					X

* When applicable.



DUST AND CRYSTALLINE SILICA WARNING



REVISED JUNE 1, 2017

WARNING

Grinding/cutting/drilling of masonry, concrete, metal and other materials can generate dust, mists and fumes containing chemicals known to cause serious or fatal injury or illness, such as respiratory disease, cancer, birth defects or other reproductive harm. If you are unfamiliar with the risks associated with the particular process and/or material being cut or the composition of the tool being used, review the material safety data sheets and/or consult your employer, the manufacturers/suppliers, governmental agencies such as OSHA and NIOSH and other sources on hazardous materials. California and some other authorities, for instance, have published lists of substances known to cause cancer, reproductive toxicity, or other harmful effects.

Control dust, mist and fumes at the source where possible. In this regard use good work practices and follow the recommendations of the manufacturers/suppliers, OSHA/NIOSH, and occupational and trade associations. Water should be used for dust suppression when wet grinding/cutting/drilling is feasible. When the hazards from inhalation of dust, mists and fumes cannot be eliminated, the operator and any bystanders should always wear a respirator approved by NIOSH/MSHA for the material being used.

WARNING

Grinding/cutting/drilling of masonry, concrete and other materials with silica in their composition may give off dust or mists containing crystalline silica. Silica is a basic component of sand, quartz, brick clay, granite and numerous other minerals and rocks. Repeated and/or substantial inhalation of airborne crystalline silica can cause serious or fatal respiratory diseases, including silicosis. In addition, California and some other authorities have listed respirable crystalline silica as a substance known to cause cancer. When grinding/cutting/drilling such materials, always follow the respiratory precautions mentioned above.

See more on the importance of dust prevention and silica warnings at osha.gov/silica.

TO PURCHASE THIS PRODUCT PLEASE CONTACT US



**Equipment Financing and
Extended Warranties Available**



**Discount-Equipment.com is your online resource for
commercial and industrial quality parts and equipment sales.**

561-964-4949

visit us on line @ www.discount-equipment.com

Select an option below to find your Equipment

Search by Manufacturer

Search by Product Type

Request a Quote

We sell worldwide for the brands: Genie, Terex, JLG, MultiQuip, Mikasa, Essick, Whiteman, Mayco, Toro Stone, Diamond Products, Generac Magnum, Airman, Haulotte, Barreto, Power Blanket, Nifty Lift, Atlas Copco, Chicago Pneumatic, Allmand, Miller Curber, Skyjack, Lull, Skytrak, Tsurumi, Husquvarna Target, Stow, Wacker, Sakai, Mi-T-M, Sullair, Basic, Dynapac, MBW, Weber, Bartell, Bennar Newman, Haulotte, Ditch Runner, Menegotti, Morrison, Contec, Buddy, Crown, Edco, Wyco, Bomag, Laymor, EZ Trench, Bil-Jax, F.S. Curtis, Gehl Pavers, Heli, Honda, ICS/PowerGrit, IHI, Partner, Imer, Clipper, MMD, Koshin, Rice, CH&E, General Equipment, Amida, Coleman, NAC, Gradall, Square Shooter, Kent, Stanley, Tamco, Toku, Hatz, Kohler, Robin, Wisconsin, Northrock, Oztec, Toker TK, Rol-Air, APT, Wylie, Ingersoll Rand / Doosan, Innovatech, Con X, Ammann, Mecalac, Makinex, Smith Surface Prep, Small Line, Wanco, Yanmar