



PARTS LIST MANUAL

CRETE-PLANE® MODEL CPU10FC



GASOLINE MODEL



ELECTRIC MODEL

10" SELF-PROPELLED CRETE-PLANERS®

*SKU #	MODEL #	POWER OPTION
73400	CPU10FC-20H	HONDA GASOLINE ENGINE MODEL GX630
73500	CPU10FC-13H	HONDA GASOLINE ENGINE MODEL GX390
73600-230	CPU10FC-10B/230/3	BALDOR ELECTRIC MOTOR 10HP 60Hz 3PH 230V
73600-460	CPU10FC-10B/460/3	BALDOR ELECTRIC MOTOR 10HP 60Hz 3PH 460V

*ADD A "4" OR "6" SUFFIX TO SKU # FOR 4 OR 6 SHAFT DRUM.

*ADD A "R" SUFFIX TO SKU # FOR OUTRIGGER FRONT WHEEL ASSEMBLY OPTION.

READ AND UNDERSTAND THE OPERATOR'S SAFETY MANUAL THOROUGHLY BEFORE ATTEMPTING TO OPERATE THIS EQUIPMENT.

Death or serious injury could occur if this machine is used improperly.

Machine specific Operator's Instruction Manuals are offered at <https://discount-equipment.com>

READ AND UNDERSTAND THE ENGINE MANUFACTURERS INSTRUCTIONS AND OPERATORS MANUAL BEFORE OPERATION.



PARTS FINDER

**Search Website
by Part Number**



**Search Manual
Library For Parts
Manual & Lookup Part
Numbers – Purchase
or Request Quote**

Search Manuals

Enter your information to help us find the right parts manual for your machine.

* Brand:

* Model:

* Serial:

* Part Number:

SEARCH

**Can't Find Part or
Manual? Request Help
by Manufacturer,
Model & Description**

Parts Order Form

Please fill in the following information to help us find the right part for your machine.

Manufacturer:	<input type="text"/>
Model:	<input type="text"/>
Description:	<input type="text"/>
Part Number:	<input type="text"/>
Quantity:	<input type="text"/>
Notes:	<input type="text"/>

Submit

Discount-Equipment.com is your online resource for quality parts & equipment.

Florida: **561-964-4949** Outside Florida TOLL FREE: **877-690-3101**

Need parts?

Click on this link: <http://www.discount-equipment.com/category/5443-parts/> and choose one of the options to help get the right parts and equipment you are looking for. Please have the machine model and serial number available in order to help us get you the correct parts. If you don't find the part on the website or on one of the online manuals, please fill out the request form and one of our experienced staff members will get back to you with a quote for the right part that your machine needs.

We sell worldwide for the brands: Genie, Terex, JLG, MultiQuip, Mikasa, Essick, Whiteman, Mayco, Toro Stone, Diamond Products, Generac Magnum, Airman, Haulotte, Barreto, Power Blanket, Nifty Lift, Atlas Copco, Chicago Pneumatic, Allmand, Miller Curber, Skyjack, Lull, Skytrak, Tsurumi, Husquvarna Target, Stow, Wacker, Sakai, Mi-T-M, Sullair, Basic, Dynapac, MBW, Weber, Bartell, Bennar Newman, Haulotte, Ditch Runner, Menegotti, Morrison, Contec, Buddy, Crown, Edco, Wyco, Bomag, Laymor, EZ Trench, Bil-Jax, F.S. Curtis, Gehl Pavers, Heli, Honda, ICS/PowerGrit, IHI, Partner, Imer, Clipper, MMD, Koshin, Rice, CH&E, General Equipment, Amida, Coleman, NAC, Gradall, Square Shooter, Kent, Stanley, Tamco, Toku, Hatz, Kohler, Robin, Wisconsin, Northrock, Oztec, Toker TK, Rol-Air, APT, Wylie, Ingersoll Rand / Doosan, Innovatech, Con X, Ammann, Mecalac, Makinex, Smith Surface Prep, Small Line, Wanco, Yanmar

**SAFETY INFORMATION****SAFETY MESSAGES**

• Safety Instructions are preceded by a graphic alert symbol of DANGER, WARNING, or CAUTION.

DANGER

Indicates an imminent hazard which, if not avoided, will result in death or serious injury.

WARNING

Indicates an imminent hazard which, if not avoided, can result in death or serious injury.

CAUTION

Indicates hazards which, if not avoided, could result in serious injury and or damage to the equipment.

GASOLINE / PROPANE POWERED EQUIPMENT**WARNING**

• Engine exhaust from this product contains chemicals known to the State of California to cause cancer, birth defects or other reproductive harm.

WARNING

• Tilting a gasoline powered machine fitted with an EPA approved vented charcoal filter gas cap, beyond 20° can cause fuel leakage. If a leak occurs, do not start or run the engine until the leak is fixed. Eliminate all other ignition sources in the immediate area (no smoking, flares, sparks or flames). Use approved gasoline absorbing material to contain the fuel leakage. Then use clean, non-sparking tools to collect absorbed materials then dispose of these contaminants properly.



• Gasoline is extremely flammable and poisonous. It should only be dispensed in well ventilated areas, and with a cool engine.

• Small gasoline engines produce high concentrations of carbon monoxide (CO) example: a 5 HP 4 cycle engine operation in an enclosed 100,000 cu. ft. area with only one change of air per hour is capable of providing deadly concentrations of CO in less than fifteen minutes. Five changes of air in the same area will produce noxious fumes in less than 30 minutes. Gasoline powered equipment should not be used in enclosed or partially enclosed areas. Symptoms of CO poisoning include, head-ache, nausea, weakness, dizziness, visual problems and loss of consciousness. If symptoms occur - get into fresh air and seek medical attention immediately.

- Never refuel a hot engine or an engine while it is running.
- Engines are shipped from factory without fuel/oil.



• Propane is extremely flammable and is heavier than air and tends to settle in low areas where a spark or flame could ignite gas. DO NOT start or operate this propane engine in a poorly ventilated area where leaking propane gas could accumulate and endanger safety of persons in area. If headache develops, shut off machine. Have it checked for carbon monoxide emissions by a qualified technician before using it again. To ensure personal safety, installation and repair of propane fuel supply systems must be performed only by qualified technicians. Carbon monoxide emissions from this machine are greatly increased due to a dirty combustion air cleaner.

ELECTRICAL POWERED EQUIPMENT

Extreme care must be taken when operating electric models with water present: Ensure power cord is properly grounded, is attached to a Ground-Fault-Interrupter (GFI) outlet, and is undamaged.

- Check all electrical cables - be sure connections are tight and cable is continuous and in good condition. Be sure cable is correctly rated for both the operating current and voltage of this equipment.
- Improper connection of the equipment grounding conductor can result in a risk of electric shock. Check with qualified electrician or service person if there is any doubt as to whether the outlet is properly grounded. Adhere to all local codes and ordinances.
- NOTE: In the event of a malfunction or breakdown, grounding provides a path of least resistance for the electric current to dissipate. The motor is equipped with a grounded plug and must be connected to an outlet that is properly installed and properly grounded. DO NOT modify the plug provided on the motor. If the plug does not fit the outlet have a qualified electrician install the proper receptacle.

ELECTRICAL POWERED EQUIPMENT CONTINUED

- Do not disconnect power by pulling cord. To disconnect, grasp the plug, not the cord.
- Unplug power cord at the machine when not in use and before servicing.
- Switch motor OFF before disconnecting power.
- Never use frayed, damaged, taped or under rated extension cords. Electrical shock could result in death or serious injury to the operator and damage to the equipment.
- Assure you are using the proper extension cord length.

GENERAL INSTRUCTIONS

- Equipment should only be operated by trained personnel in good physical condition and mental health (not fatigued). The operator and maintenance personnel must be physically able to handle the bulk weight and power of this equipment.
- This is a one person tool. Maintain a safe operating distance to other personnel. It is the operators' responsibility to keep other people (workers, pedestrians, bystanders, etc.) away during operation. Block off the work area in all directions with roping, safety netting, etc. Failure to do so may result in others being injured by flying debris or exposing them to harmful dust and noise.
- This equipment is intended for commercial use only.
- For the operator's safety and the safety of others, always keep all guards in place during operation.
- Never let equipment run unattended.



- Personal Protection Equipment and proper safety attire must be worn when operating this machinery. The operator must wear approved safety equipment appropriate for the job such as hard hat and safety shoes when conditions require. Hearing protection MUST be used when operational noise levels of this equipment may exceed 85db. Eye protection MUST be worn at all times.



Keep body parts, loose clothing and accessories away from moving parts. Failure to do so could result in dismemberment or death.

- Do not modify the machine.
- Stop motor/engine when adjusting or servicing this equipment. Maintain a safe operating distance from flammable materials. Sparks from the cutting-action of this machine can ignite flammable materials or vapors.

**DUST WARNING****WARNING**

Some dust created by power sanding, sawing, grinding, drilling, and other construction activities contains chemicals known to cause cancer, birth defects, or other reproductive harm. Materials being removed can be toxic or hazardous. A breathing respirator is required to help protect the operator.

Some examples of these chemicals are:

- Lead from lead-based paints.
- Crystalline silica from bricks, concrete and other masonry products. Your risk of exposure to these chemicals varies depending on how often you do this type of work. To reduce your risk: work in a well ventilated area, use a dust control system, such as an industrial-style vacuum, and wear approved personal safety equipment, such as a dust/particle respirator designed to filter out microscopic particles.
- See more on the importance of dust prevention and silica warnings at: osha.gov/silica

PARTS LIST MANUAL

CRETE-PLANE® MODEL CPU10FC

E-CPU10FC-PL-1018

TABLE OF CONTENTS

<u>Section</u>	<u>Page Number</u>
Safety Information	2
How To Order Replacement Parts	3
Illustration 1: Frame, Console & Belt Cover Grouping	4, 5
Illustration 2: Lifting System Grouping for Standard Front Wheels	6, 7
Illustration 3: Lifting System Grouping for Optional Outrigger Front Wheels	8, 9
Illustration 4: Rear Axle Grouping	10, 11
Illustration 5: Transmission, Drive Lever & Linkage Grouping	12, 13
Illustration 6: Clutch Grouping	14, 15
Illustration 7: Clutch Lever & Linkage Grouping	16, 17
Illustration 8: Water Valve & Spray Nozzle Grouping	18
Illustration 9: Hood and Rubber Seal Grouping	19
Illustration 10: Drum Shaft & Bearing Grouping	20, 21
Illustration 11: 4-Shaft Cutter Drum Assembly	22
Illustration 12: 6-Shaft Cutter Drum Assembly	23
Illustration 13: Diamond Grooving Head Assembly	24
Diamond Grooving Set-ups	25, 26, 27
Illustration 14: Engine Grouping for Honda GX630	28, 29
Illustration 15: Fuel Tank Grouping for Honda GX630	30, 31
Illustration 16: Battery Grouping	32, 33
Illustration 17: Engine Grouping for Honda GX390	34, 35
Illustration 18: Motor Grouping for Electric Models	36, 37
Illustration 19: Starter & Transformer Box Grouping	38, 39
Illustration 20: Belt Drive Grouping for Honda GX630 Engine	40
Illustration 21: Belt Drive Grouping for Honda GX390 Engine	41
Illustration 22: Belt Drive Grouping for Baldor 10 HP Motor	42
Illustration 23: Idler Arm Grouping for Transmission Belt	43
Wiring Diagram for Honda GX630	44
Wiring Diagram for Honda GX390	45
Wiring Diagram for Electric Units	46
Starter Cord Arrangement	47
Connection Diagram for Motor	48
Decal Sheet 1	49
Decal Sheet 2	50
Limited Equipment Warranty of Sale - Terms & Conditions	51
STOP - Before Using This Product	52

ILLUSTRATION 1: FRAME, CONSOLE & BELT COVER GROUPING

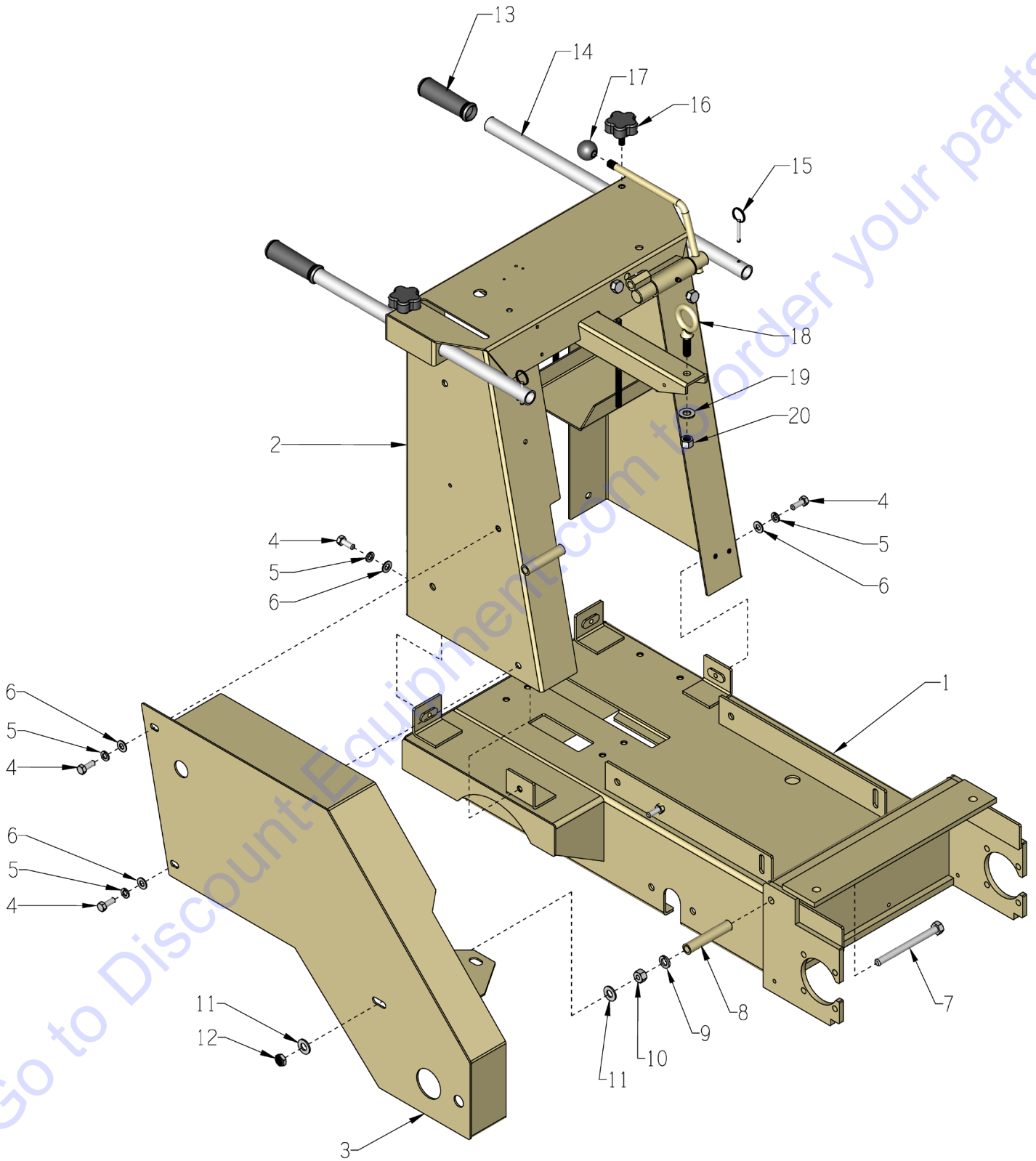

PARTS LISTING - ILLUSTRATION 1: FRAME, CONSOLE & BELT COVER GROUPING			
ITEM #	PART #	DESCRIPTION	QTY.
1	64401	MAIN FRAME, CPU10FC	1
2	64007	CONSOLE, CPU-10	1
3	64070	COVER, BELT, CPU-10	1
4	10055	SCREW, CAP 3/8-16 X 1	5
5	10811	WASHER, LOCK 3/8 ZINC	5
6	10025	WASHER, FLAT 3/8 SAE ZINC	5
7	64071	SCREW, CAP 1/2-13 X 5-1/2	1
8	64072	SPACER, BELT COVER, 1/2"ID X 3-7/8"	1
9	10045	WASHER, LOCK 1/2 ZINC	1
10	10417	NUT, HEX 1/2-13 ZINC	1
11	10312	WASHER, FLAT 1/2 SAE ZINC	2
12	10157	NUT, HEX NYLON JAM 1/2-13 ZINC	1
13	10608	GRIP, HAND 1" MODEL AT	2
14	51024	HANDLE BAR 24", ZINC PLATED	2
15	10145	PIN, DETENT RING 3/16 X 1-5/16 E.L.	2
16	51230	KNOB, STAR CLAMPING 3/8-16 X 1"STUD	2
17	14023	KNOB, BALL 1-3/8 W/ 1/2-13THD, BLK.	1
18	10837	BOLT, EYE 1/2-13 X 1-1/2 X 1-1/8"ID	1
19	10312	WASHER, FLAT 1/2 SAE ZINC	1
20	10155	NUT, HEX NYLON LOCK 1/2-13 ZINC	1

ILLUSTRATION 2: LIFTING SYSTEM GROUPING FOR STANDARD FRONT WHEELS

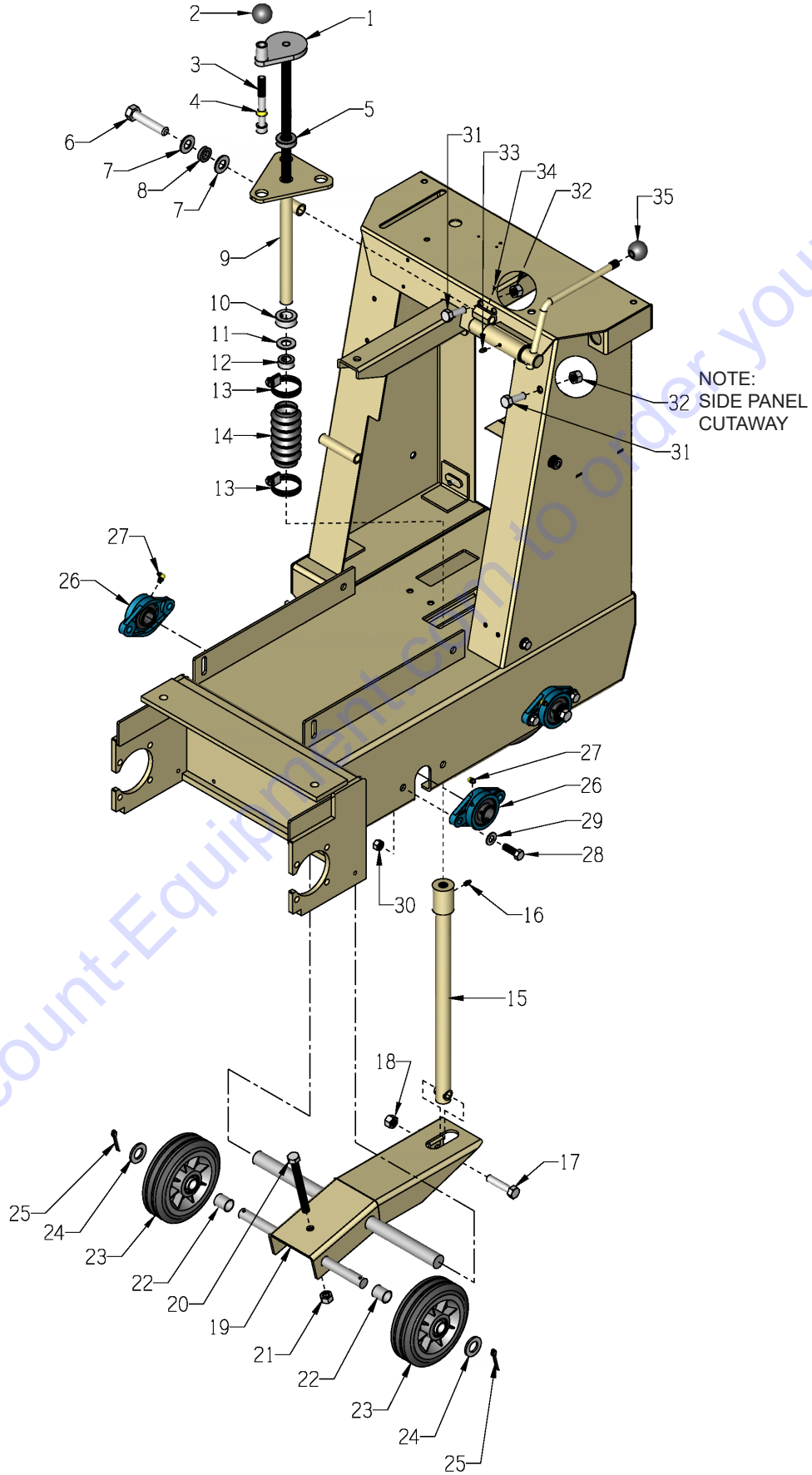

PARTS LISTING - ILLUSTRATION 2: LIFTING SYSTEM GROUPING FOR STANDARD FRONT WHEELS			
ITEM #	PART #	DESCRIPTION	QTY.
1	64011	HANDWHEEL, SMALL W/ 5/8-8 X 20"ROD	1
2	14023	KNOB, BALL 1-3/8 W/ 1/2-13THD, BLK.	1
3	10411	SCREW, SKT. HD. CAP 1/2-13 X 4 ZINC	1
4	50550	SLEEVE, BRASS 1/2" TAPERED	1
5	85005	BEARING, THRUST BALL 5/8	1
6	10326	SCREW, CAP 5/8-11 X 3	1
7	10073	WASHER, FLAT 5/8 SAE ZINC	2
8	79035	BUSHING, RUBBER 1-1/16 X 5/8 X 1/4	1
9	64013	LINKAGE, UPPER SUPPORT, CPU-10	1
10	10440	COLLAR, LOCKING 7/8"ID	1
11	10073	WASHER, FLAT 5/8 SAE ZINC	1
12	10096	COLLAR, LOCKING 5/8"ID	1
13	10784	CLAMP, HOSE, SAE #20, ADJ. TO 1-3/4	2
14	10930	BELLOWS 1-1/4ID X 2-3/8EL X 1-3/4RL	1
15	64012	LINKAGE, LOWER CONTROL 18"L, CPU-10	1
16	10808	FITTING, GREASE 1/4-28 STRAIGHT	1
17	10347	SCREW, CAP 1/2-20 X 2-1/4	1
18	10154	NUT, HEX NYLON LOCK 1/2-20 ZINC	1
19	64006	FORK, CPU-10	1
20	10373	BOLT, TAP 1/2-13 X 5 (FULL THREAD)	1
21	10417	NUT, HEX 1/2-13 ZINC	1
22	64031	SPACER, WHEEL 3/4 X 1, CPU-10	2
23	80028	WHEEL 6 X 2 X 3/4"BRG.	2
24	10009	WASHER, FLAT 3/4 SAE ZINC	2
25	10306	PIN, COTTER 3/16 X 1-1/2	2
26	62022	BEARING, BALL 1" 2-HOLE FLANGE	2
27	10961	FITTING, GREASE 1/4-28 X 90°	2
28	10003	SCREW, CAP 7/16-20 X 1-1/4 ZINC	4
29	10062	WASHER, FLAT 7/16 SAE ZINC	4
30	10153	NUT, HEX NYLON LOCK 7/16-20 ZINC	4
31	10308	SCREW, CAP 1/2-20 X 1-1/2	2
32	10154	NUT, HEX NYLON LOCK 1/2-20 ZINC	2
33	10808	FITTING, GREASE 1/4-28 STRAIGHT	1
34	10127	SCREW, DRIVE 1/8 X 1/4"L	1
35	14023	KNOB, BALL 1-3/8 W/ 1/2-13THD, BLK.	1

ILLUSTRATION 3: LIFTING SYSTEM GROUPING FOR OPTIONAL OUTRIGGER FRONT WHEELS

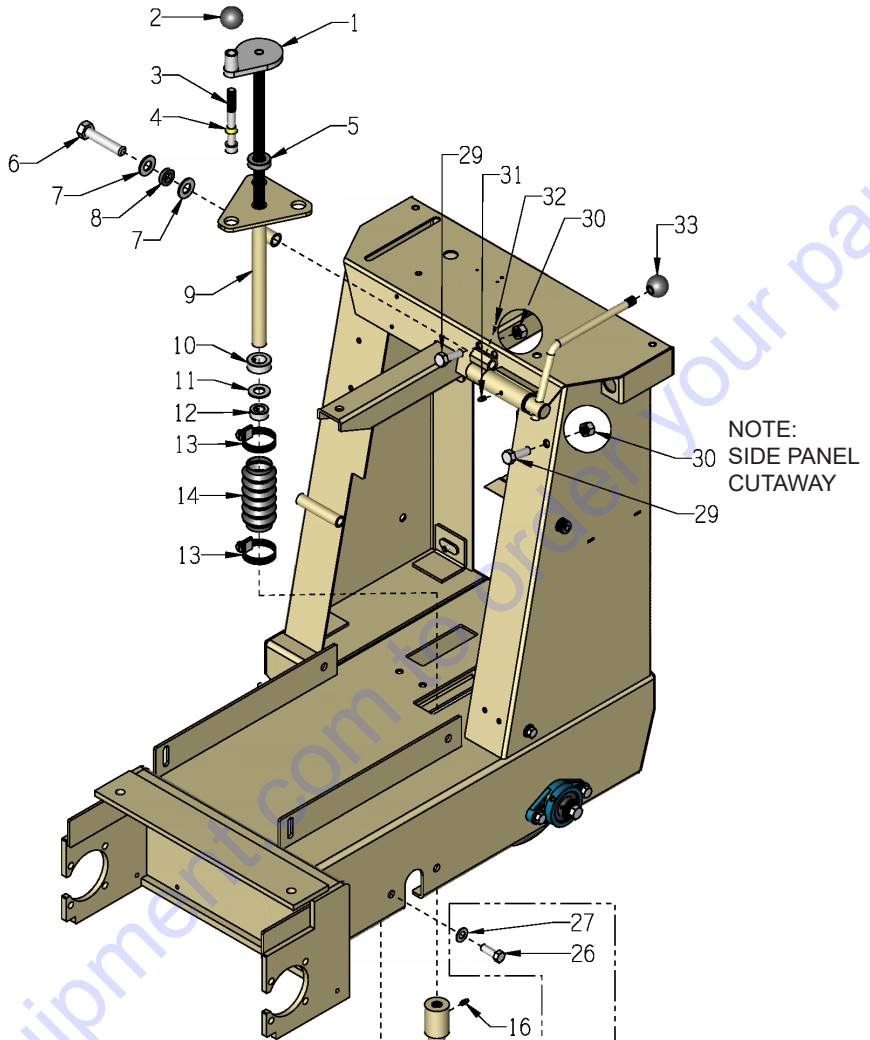

*ADD A "R" SUFFIX TO SKU # FOR OPTIONAL OUTRIGGER FRONT WHEEL ASSEMBLY. (SEE MODELS BELOW)

MODELS:

- 73400-4-R
- 73400-6-R
- 73500-4-R
- 73500-6-R
- 73600-230-4-R
- 73600-230-6-R
- 73600-460-4-R
- 73600-460-6-R

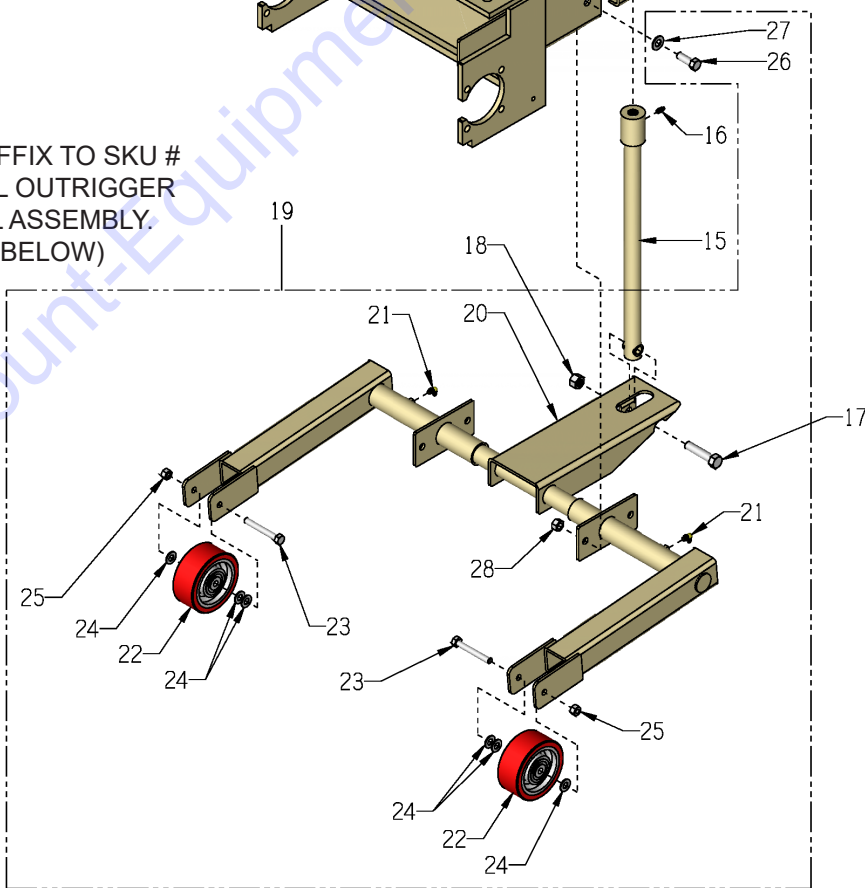

PARTS LISTING - ILLUSTRATION 3: LIFTING SYSTEM GROUPING FOR OPTIONAL OUTRIGGER FRONT WHEELS			
ITEM #	PART #	DESCRIPTION	QTY.
1	64011	HANDWHEEL, SMALL W/ 5/8-8 X 20"ROD	1
2	14023	KNOB, BALL 1-3/8 W/ 1/2-13THD, BLK.	1
3	10411	SCREW, SKT. HD. CAP 1/2-13 X 4 ZINC	1
4	50550	SLEEVE, BRASS 1/2" TAPERED	1
5	85005	BEARING, THRUST BALL 5/8	1
6	10326	SCREW, CAP 5/8-11 X 3	1
7	10073	WASHER, FLAT 5/8 SAE ZINC	2
8	79035	BUSHING, RUBBER 1-1/16 X 5/8 X 1/4	1
9	64013	LINKAGE, UPPER SUPPORT, CPU-10	1
10	10440	COLLAR, LOCKING 7/8"ID	1
11	10073	WASHER, FLAT 5/8 SAE ZINC	1
12	10096	COLLAR, LOCKING 5/8"ID	1
13	10784	CLAMP, HOSE, SAE #20, ADJ. TO 1-3/4	2
14	10930	BELLOWS 1-1/4ID X 2-3/8EL X 1-3/4RL	1
15	64012	LINKAGE, LOWER CONTROL 18"L, CPU-10	1
16	10808	FITTING, GREASE 1/4-28 STRAIGHT	1
17	10347	SCREW, CAP 1/2-20 X 2-1/4	1
18	10154	NUT, HEX NYLON LOCK 1/2-20 ZINC	1
19	64450	OUTRIGGER WHEEL ASSY., CPU10FC (INCLUDES ITEMS 20 THRU 28)	1
20	64451	FORK, OUTRIGGER, CPU10FC	1
21	10961	FITTING, GREASE 1/4-28 X 90°	2
22	10932	WHEEL 4 X 1-1/2 X 3/8"BRG., POLY	2
23	10815	SCREW, CAP 3/8-24 X 2-3/4	2
24	10025	WASHER, FLAT 3/8 SAE ZINC	6
25	10004	NUT, HEX LOCK 3/8-24 ZINC	2
26	10003	SCREW, CAP 7/16-20 X 1-1/4 ZINC	4
27	10062	WASHER, FLAT 7/16 SAE ZINC	4
28	10153	NUT, HEX NYLON LOCK 7/16-20 ZINC	4
29	10308	SCREW, CAP 1/2-20 X 1-1/2	2
30	10154	NUT, HEX NYLON LOCK 1/2-20 ZINC	2
31	10808	FITTING, GREASE 1/4-28 STRAIGHT	1
32	10127	SCREW, DRIVE 1/8 X 1/4"L	1
33	14023	KNOB, BALL 1-3/8 W/ 1/2-13THD, BLK.	1

ILLUSTRATION 4: REAR AXLE GROUPING

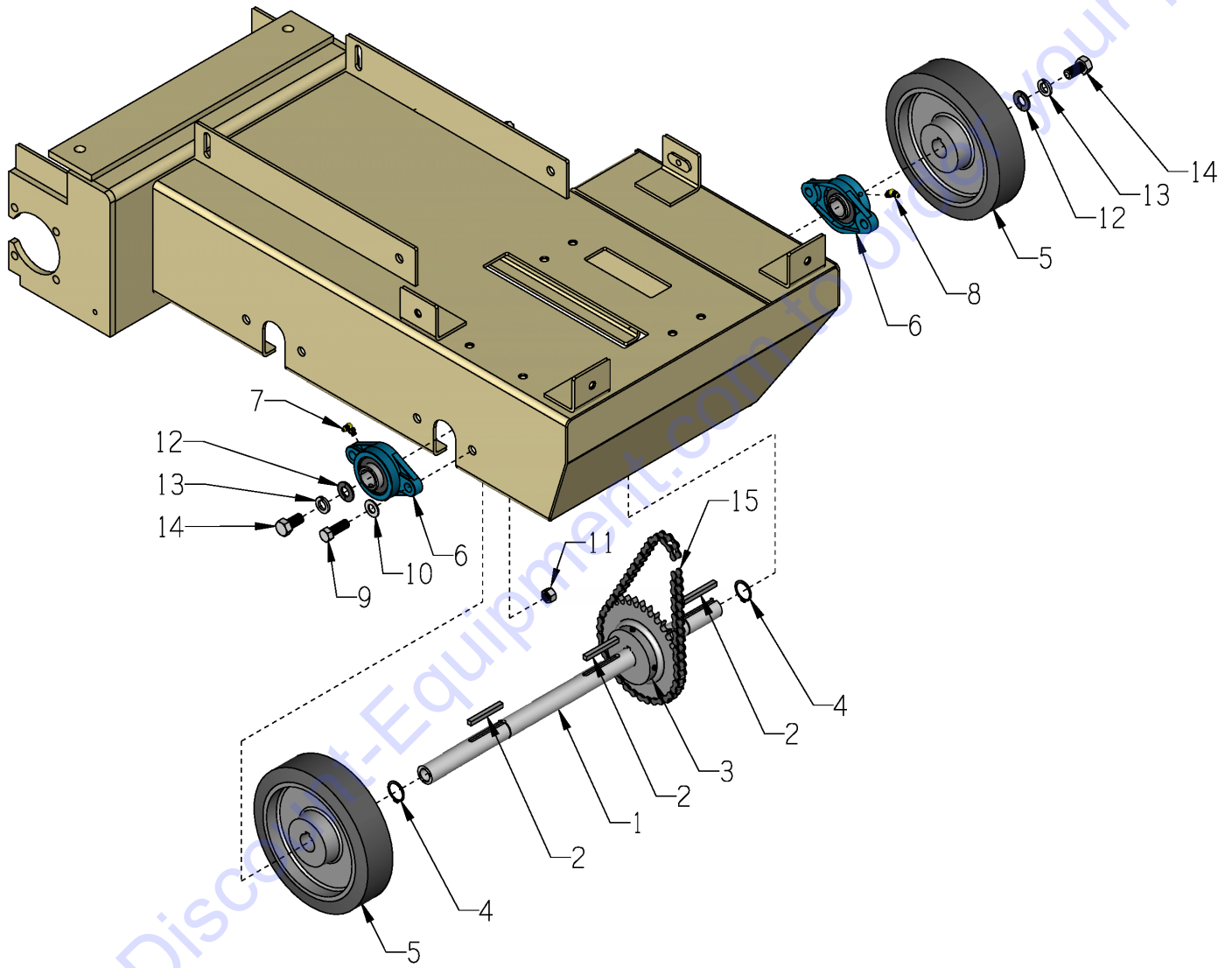

PARTS LISTING
ILLUSTRATION 4: REAR AXLE GROUPING

ITEM #	PART #	DESCRIPTION	QTY.
1	64028	AXLE SHAFT 1"DIA. X 20-3/8"L, CPU10	1
2	10307	KEY 1/4SQ X 2-1/4	3
3	61126	SPROCKET #40B34 X 1"BORE	1
4	10906	RETAINING RING, EXT. 1"	2
5	50098	WHEEL 8 X 2 X 1"BORE	2
6	62022	BEARING, BALL 1" 2-HOLE FLANGE	2
7	10961	FITTING, GREASE 1/4-28 X 90°	1
8	10960	FITTING, GREASE 1/4-28 X 45°	1
9	10003	SCREW, CAP 7/16-20 X 1-1/4 ZINC	4
10	10062	WASHER, FLAT 7/16 SAE ZINC	4
11	10153	NUT, HEX NYLON LOCK 7/16-20 ZINC	4
12	10433	WASHER, BELLEVILLE 1/2ID X 3/32THK	2
13	10045	WASHER, LOCK 1/2 ZINC	2
14	10914	SCREW, CAP 1/2-13 X 1	2
15	64033	CHAIN #40 X 25-3/4" + OL + CL	

ILLUSTRATION 5: TRANSMISSION, DRIVE LEVER & LINKAGE GROUPING

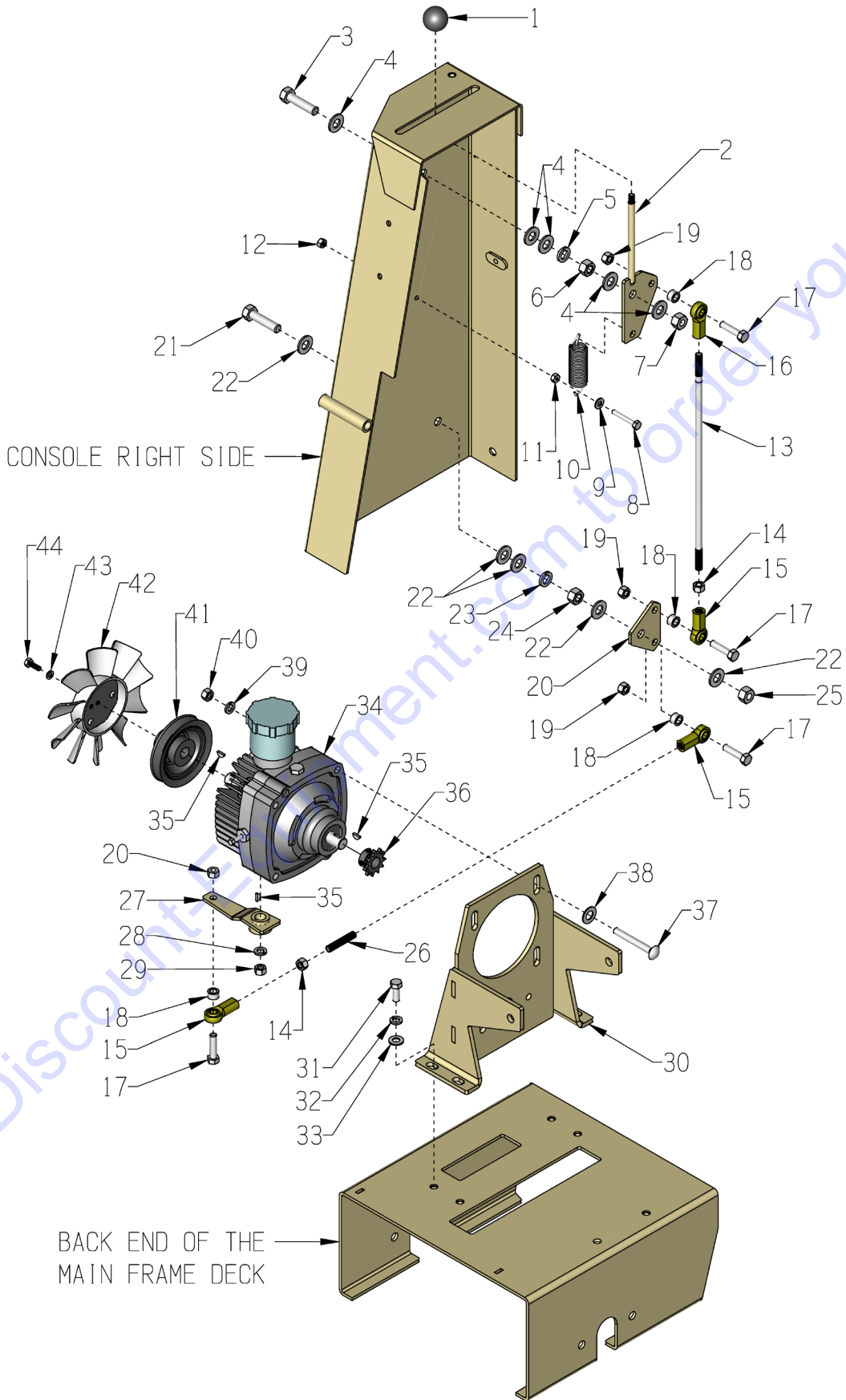

**PARTS LISTING - ILLUSTRATION 5:
TRANSMISSION, DRIVE LEVER & LINKAGE GROUPING**

ITEM #	PART #	DESCRIPTION	QTY.	ITEM #	PART #	DESCRIPTION	QTY.
1	10920	KNOB, BALL 1-3/8 W/ 5/16-24THD	1	23	10045	WASHER, LOCK 1/2 ZINC	1
2	64020	LEVER, DRIVE, CPU-10	1	24	10417	NUT, HEX 1/2-13 ZINC	1
3	10322	SCREW, CAP 1/2-20 X 2	1	25	10154	NUT, HEX NYLON LOCK 1/2-20	1
4	10312	WASHER, FLAT 1/2 SAE ZINC	5	26	64024	ROD, ALLTHREAD 3/8-24 X 2"L	1
5	10045	WASHER, LOCK 1/2 ZINC	1	27	64022	TRANS. CONTROL ARM, CPU-10	1
6	10417	NUT, HEX 1/2-13 ZINC	1	28	10811	WASHER, LOCK 3/8 ZINC	1
7	10154	NUT, HEX NYLON LOCK 1/2-20	1	29	10404	NUT, HEX 3/8-16 ZINC	1
8	10314	SCREW, CAP 1/4-20 X 1-3/4	1	30	64018	MOUNT, TRANSMISSION, CPU-10	1
9	10602	WASHER, FLAT 1/4 SAE ZINC	1	31	10055	SCREW, CAP 3/8-16 X 1	4
10	50074	SPRING, EXT. 1"OD X 3-15/16	1	32	10811	WASHER, LOCK 3/8 ZINC	4
11	10015	NUT, HEX LOCK 1/4-20 ZINC	1	33	10025	WASHER, FLAT 3/8 SAE ZINC	4
12	10150	NUT, HEX NYLON LOCK 1/4-20	1	34	50061	TRANSMISSION, HYDROSTATIC	1
13	64023	LINKAGE, ROD 3/8 X 14-1/4"L	1	35	50071	KEY, WOODRUFF 1/8 X 1/2 (SAE #3)	3
14	10014	NUT, HEX 3/8-24 ZINC	2	36	50048	SPROCKET #3511 X .67"BORE	1
15	10919	ROD END, FEMALE 3/8-24 R.H. THREAD	3	37	10909	BOLT, CARR. 3/8-16 X 3 ZINC	4
16	10919L	ROD END, FEMALE 3/8-24 L.H. THREAD	1	38	10040	WASHER, GARRET 17/32 X 1 X .054	4
17	10816	SCREW, CAP 3/8-24 X 1-1/2	4	39	10811	WASHER, LOCK 3/8 ZINC	4
18	10011	SPACER, STEEL 5/8OD X 3/8ID X 3/8T	4	40	10404	NUT, HEX 3/8-16 ZINC	4
19	10152	NUT, HEX NYLON LOCK 3/8-24	4	41	50062	SHEAVE, TRANS. 4"OD X 1GR. X .671"B	1
20	64021	BELL CRANK, DRIVE LINKAGE	1	42	50266	FAN BLADE W/ PLATE 7", TRANS.	1
21	10322	SCREW, CAP 1/2-20 X 2	1	43	10038	WASHER, LOCK 1/4 ZINC	1
22	10312	WASHER, FLAT 1/2 SAE ZINC	5	44	10018	SCREW, CAP 1/4-20 X 3/4	1

ILLUSTRATION 6: CLUTCH GROUPING

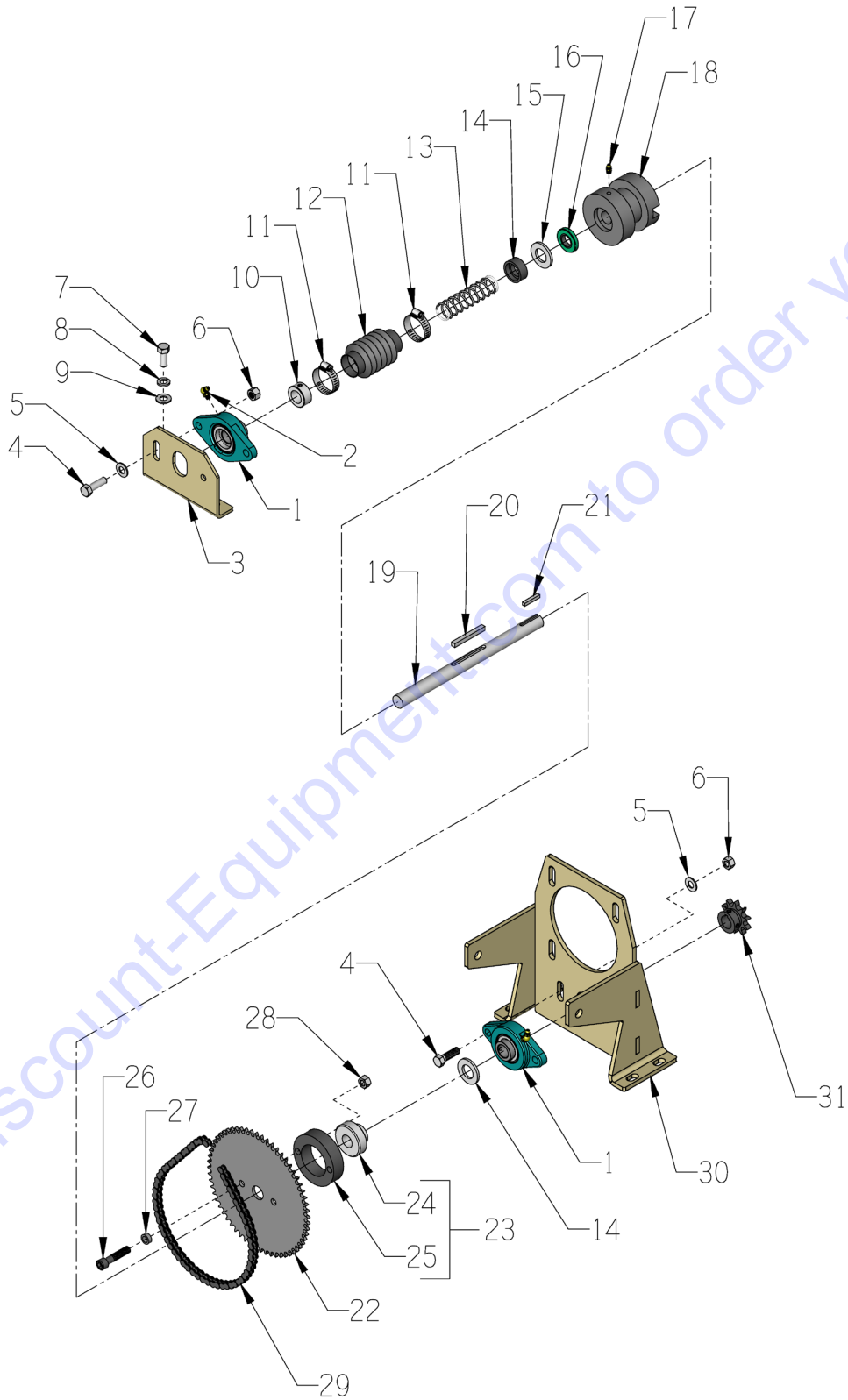

PARTS LISTING - ILLUSTRATION 6: CLUTCH GROUPING			
ITEM #	PART #	DESCRIPTION	QTY.
1	50049	BEARING, BALL 3/4" 2-HOLE FLANGE	2
2	10961	FITTING, GREASE 1/4-28 X 90°	2
3	50509	MOUNT, JACKSHAFT BEARING	1
4	10309	SCREW, CAP 3/8-24 X 1-1/4 ZINC	4
5	10025	WASHER, FLAT 3/8 SAE ZINC	4
6	10152	NUT, HEX NYLON LOCK 3/8-24 ZINC	4
7	10055	SCREW, CAP 3/8-16 X 1	2
8	10811	WASHER, LOCK 3/8 ZINC	2
9	10025	WASHER, FLAT 3/8 SAE ZINC	2
10	10428	COLLAR, LOCKING 3/4"ID	1
11	10768	CLAMP, HOSE, SAE #16, ADJ. TO 1-1/2	2
12	10930	BELLOWS 1-1/4ID X 2-3/8EL X 1-3/4RL	1
13	10922	SPRING, COMP. 1"OD X 3.75"FL	1
14	57044	CLUTCH SPRING CUP	1
15	10009	WASHER, FLAT 3/4 SAE ZINC	2
16	3695	SEAL, OIL .750 X 1.375 X .250	1
17	10808	FITTING, GREASE 1/4-28 STRAIGHT	1
18	57042	CLUTCH, DOG BLOCK	1
19	64027	JACKSHAFT, CLUTCH 10-1/2"L, CPU-10	1
20	10307	KEY 1/4SQ X 2-1/4	1
21	50523	KEY 3/16SQ X 1-1/8	1
22	50476	SPROCKET, CLUTCH #35A60	1
23	57038A	BEARING & CARRIER ASSY., CLUTCH	1
24	57038	BEARING, BALL 3/4ID X 1.8504"OD	1
25	57039	CARRIER, CLUTCH BEARING	1
26	10354	SCREW, SKT. HD. CAP 3/8-24 X 1-3/4	2
27	10113	SPACER, STEEL 9/16OD X 3/8ID X 7/32	2
28	10152	NUT, HEX NYLON LOCK 3/8-24 ZINC	2
29	64032	CHAIN #35 X 24-1/2" + CL	1
30	64018	MOUNT, TRANSMISSION, CPU-10	1
31	50436	SPROCKET #40B10 X 3/4"BORE	1

ILLUSTRATION 7: CLUTCH LEVER & LINKAGE GROUPING

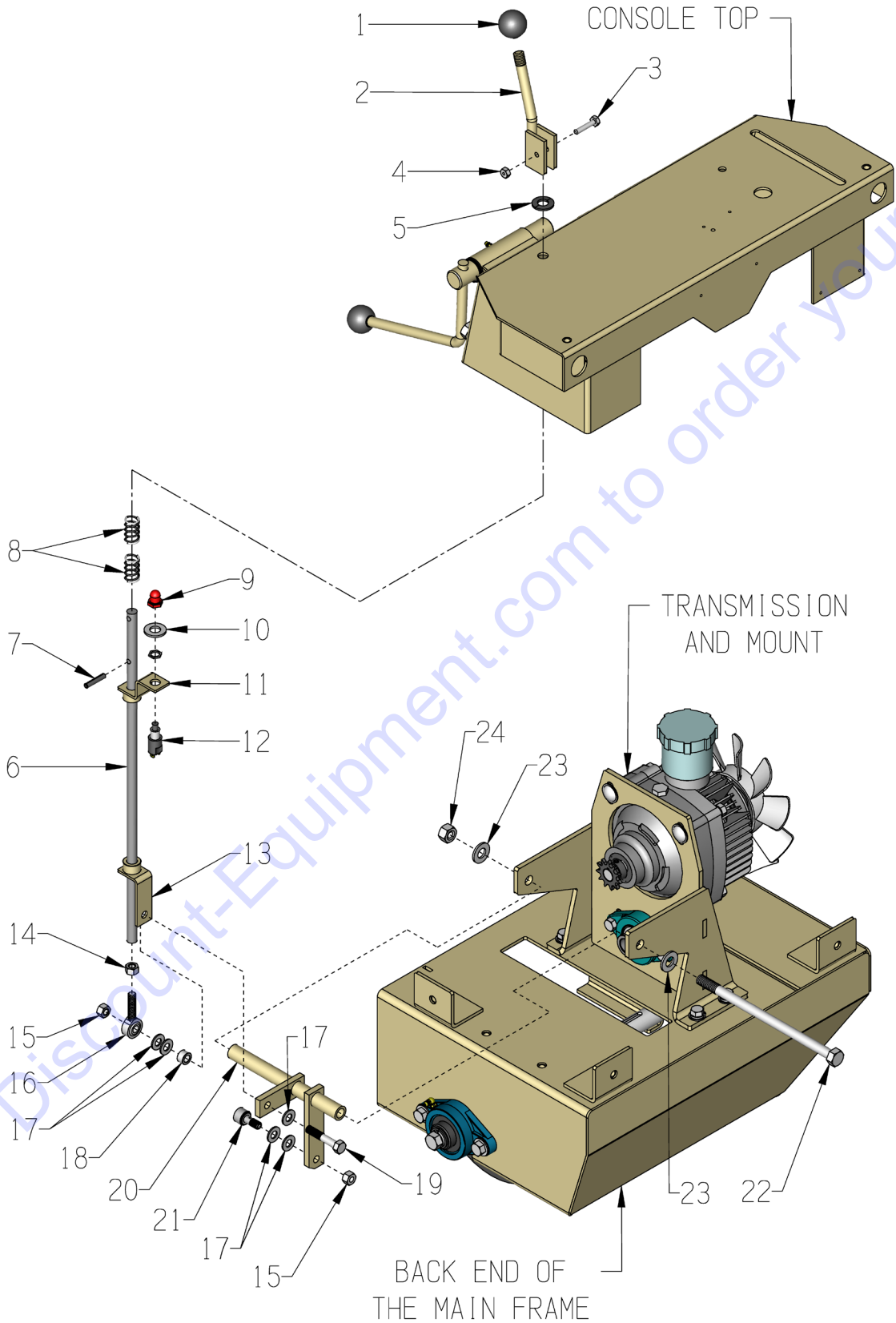

PARTS LISTING - ILLUSTRATION 7: CLUTCH LEVER & LINKAGE GROUPING			
ITEM #	PART #	DESCRIPTION	QTY.
1	14023	KNOB, BALL 1-3/8 W/ 1/2-13THD, BLK.	1
2	64025	LEVER, CLUTCH, CPU-10	1
3	10905	SCREW, CAP 1/4-20 X 1-1/4	1
4	10150	NUT, HEX NYLON LOCK 1/4-20 ZINC	1
5	10433	WASHER, BELLEVILLE 1/2ID X 3/32THK	1
6	57126	LINKAGE, CLUTCH 19-1/4", CPU10	1
7	10024	PIN, ROLL 1/4 X 1-1/4	1
8	10921	SPRING, COMP. .72"OD X 1.25"FL	2
9	10997	BOOT, RED RUBBER, STOP SWITCH	1
10	10312	WASHER, FLAT 1/2 SAE ZINC	1
11	64082	BRACKET, SAFETY SWITCH, CPU-10	1
12	10887	SWITCH, PUSHBUTTON, N.C. MOMENTARY	1
13	57151	BRACKET, CLUTCH LINKAGE LOCK	1
14	10014	NUT, HEX 3/8-24 ZINC	1
15	10152	NUT, HEX NYLON LOCK 3/8-24 ZINC	1
16	3605	ROD END, MALE 3/8-24	1
17	10025	WASHER, FLAT 3/8 SAE ZINC	5
18	10011	SPACER, STEEL 5/8OD X 3/8ID X 3/8T	1
19	10030	SCREW, CAP 3/8-24 X 2	1
20	64026	BELL-CRANK, CLUTCH, CPU-10	1
21	10924	CAM FOLLOWER BRG. 3/4" X 3/8-24THD	1
22	10408	SCREW, CAP 1/2-13 X 9	1
23	10312	WASHER, FLAT 1/2 SAE ZINC	2
24	10155	NUT, HEX NYLON LOCK 1/2-13 ZINC	1

ILLUSTRATION 8: WATER VALVE & SPRAY NOZZLE GROUPING

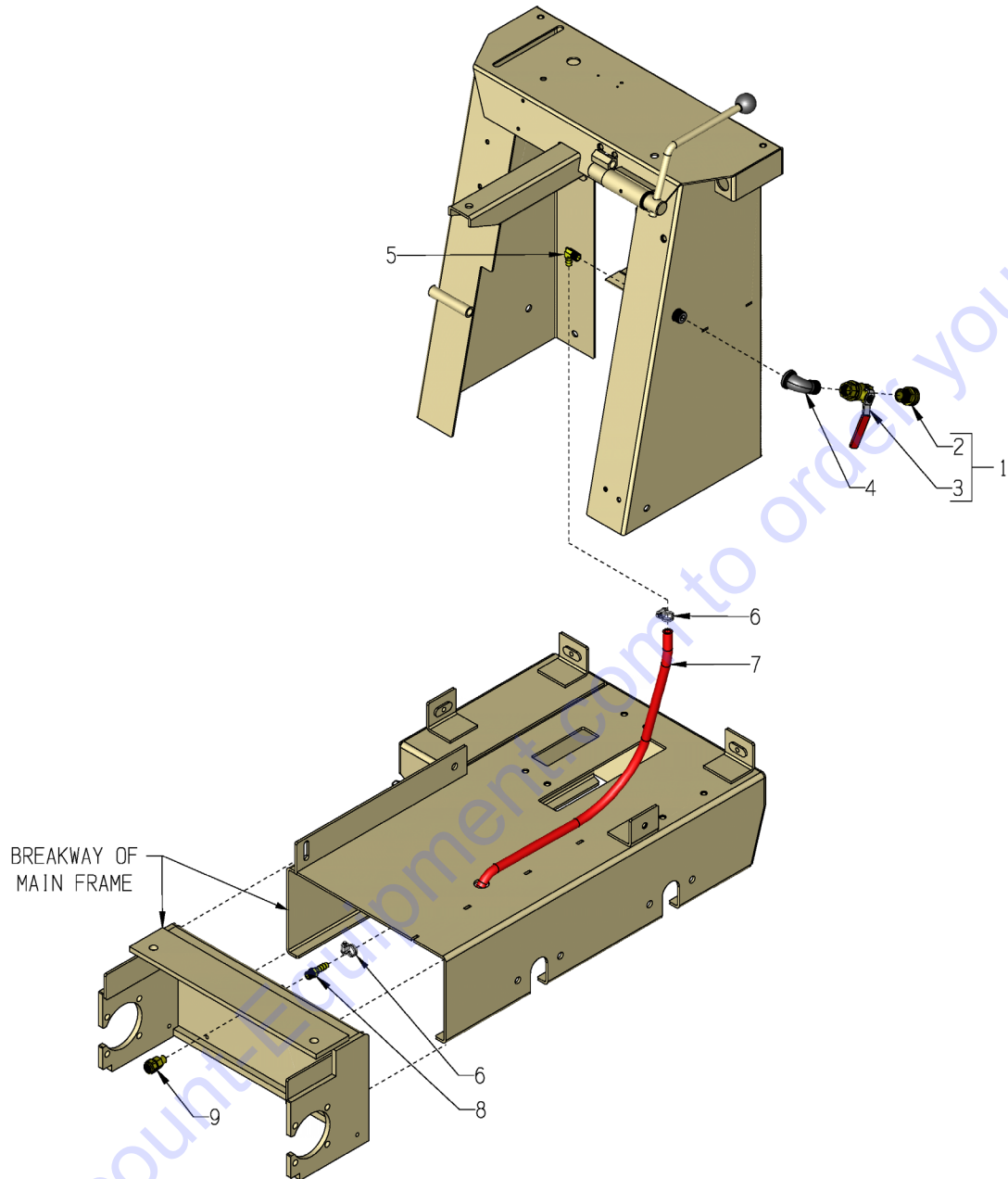

ITEM #	PART #	DESCRIPTION	QTY.
1	10711A	VALVE & HOSE CONNECTOR ASSY.	1
2	80021	CONN., SWIVEL FEM. 3/4HOSE X 1/2MPT	1
3	10711	VALVE, BALL 1/2 FPT	1
4	10724	ELBOW, STREET 1/2NPT X 90 (BLACK)	1
5	10799	BARB ELBOW 90, 3/8HOSE X 1/4MPT	1
6	50069	CLAMP, HOSE, SAE #6, ADJ. TO 13/16	2
7	64058	HOSE, WATER 3/8"ID X 35"L, CPU-10	1
8	50075	BARB, 3/8 HOSE X 1/4MPT (BRASS)	1
9	80029	NOZZLE, SPRAY 1/4NPT (BRASS)	1

ILLUSTRATION 9: HOOD AND RUBBER SEAL GROUPING

E-CPU10FC-PL-1018

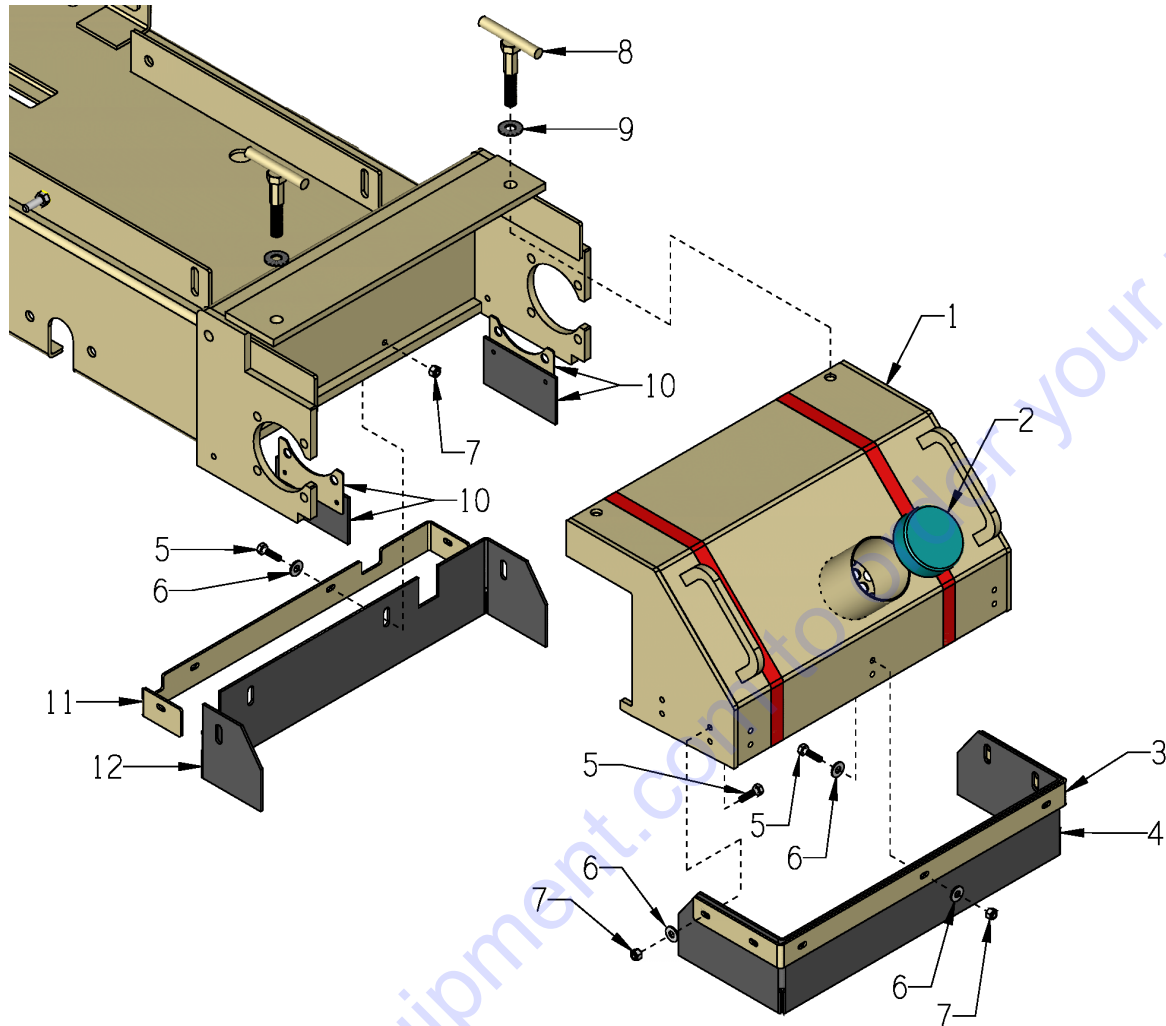

ITEM #	PART #	DESCRIPTION	QTY.
1	64402	HOOD, CPU10FC	1
2	64030	CAP, END 3" BLUE PLASTIC	1
3	64403	RETAINING BRKT., FRONT SEAL, CPU10FC	1
4	64404	RUBBER SEAL, FRONT, CPU10FC	1
5	10031	SCREW, CAP 1/4-20 X 1	11
6	10602	WASHER, FLAT 1/4 SAE ZINC	14
7	10150	NUT, HEX NYLON LOCK 1/4-20 ZINC	11
8	64003	LOCK, HOOD, CPU-10	2
9	11522	WASHER, SERRATED BELLEVILLE .489"ID	2
10	64407	RUBBER SEAL W/ BRKT., CPU10FC	2
	64408	RETAINING BRKT., SIDE SEAL	2
	64409	RUBBER SEAL, SIDE	2
	11643	RIVET, BLIND 3/16"DIA X .425"LG	4
11	64405	RETAINING BRKT., REAR SEAL, CPU10FC	1
12	64406	RUBBER SEAL, REAR, CPU10FC	1

ILLUSTRATION 10: DRUM SHAFT & BEARING GROUPING

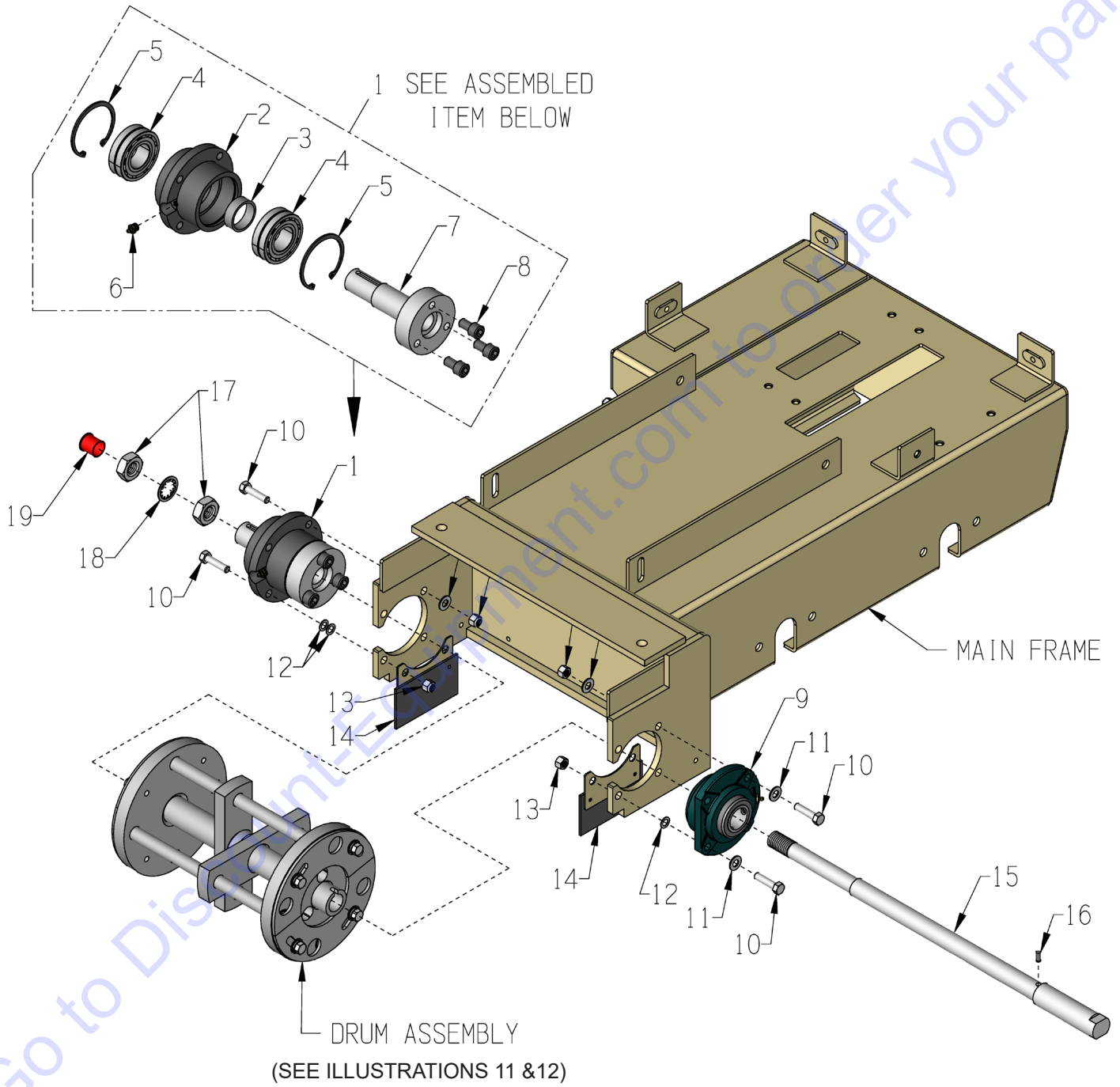

PARTS LISTING - ILLUSTRATION 10: DRUM SHAFT & BEARING GROUPING			
ITEM #	PART #	DESCRIPTION	QTY.
1	64160	BEARING & DRIVER ASSY., CPU10FC (INCLUDES ITEMS 2 THRU 8)	1
2	64151	BEARING HOUSING, CPU10FC	1
3	64153	SPACER, BEARING CENTER, CPU10FC	1
4	64152	BEARING, ROLLER 35MM X 72MM X 23MM	2
5	64154	RETAINING RING, INT. 2-13/16"	2
6	10953	FITTING, GREASE 1/8 NPT STRAIGHT	1
7	64155B	HUB W/ SHAFT, DRIVER, CPU10FC	1
8	10490	SCREW, SKT. HD. CAP 1/2-13 X 1	3
9	84082R	BEARING, ROLLER 1-1/4" PILOT (CUT)	1
10	10816	SCREW, CAP 3/8-24 X 1-1/2	8
11	10025	WASHER, FLAT 3/8 SAE ZINC	8
12	64159	SHIM 3/8 X 5/8 X .031 (*USE AS REQ'D.)	A/R*
13	10152	NUT, HEX NYLON LOCK 3/8-24 ZINC	8
14	64407	RUBBER SEAL W/ BRKT., CPU10FC (SEE ILLUS. 9)	2
15	64410	DRUM SHAFT 24", CPU10FC	1
16	64162	PIN, DOWEL 1/4 X 5/8 (OVERSIZED)	1
17	10445	NUT, HEX JAM 7/8-9 LEFT-HAND THREAD	2
18	64158	WASHER, LOCK, INT. TOOTH 7/8"	1
19	64163	CAPPLUG RC-14 RED (7/8")	1

ILLUSTRATION 11: 4-SHAFT CUTTER DRUM ASSEMBLY

*NOTE: DRUMS ARE INTERCHANGABLE

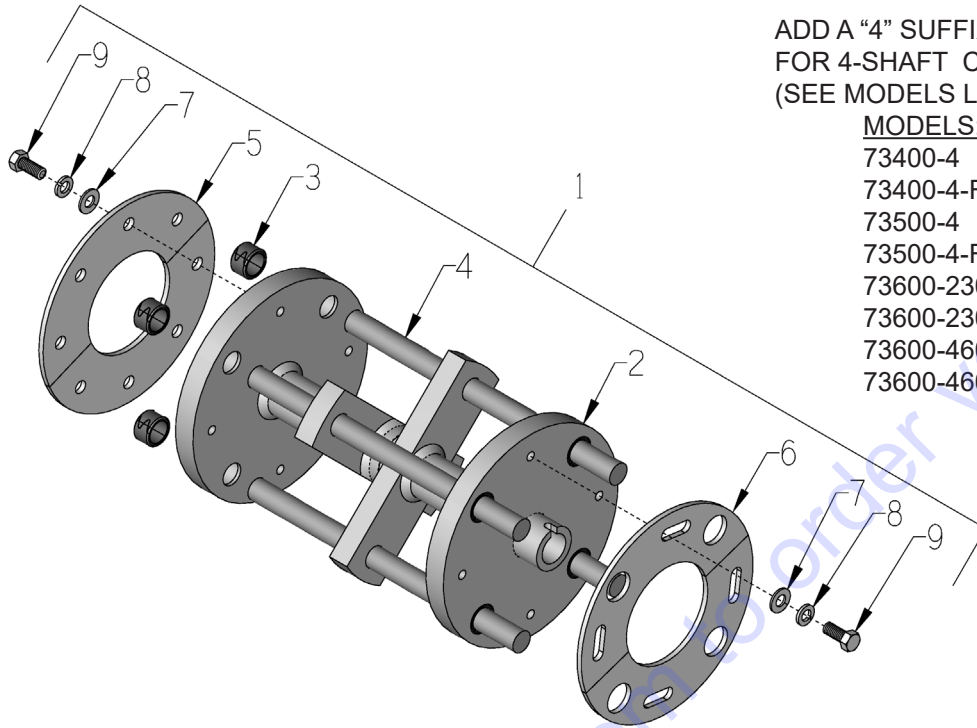

ADD A "4" SUFFIX TO SKU #
FOR 4-SHAFT CUTTER DRUM*.
(SEE MODELS LISTED BELOW)

- MODELS:**
 73400-4
 73400-4-R
 73500-4
 73500-4-R
 73600-230-4
 73600-230-4-R
 73600-460-4
 73600-460-4-R

ITEM #	PART #	DESCRIPTION	QTY.
1	64420	DRUM ASSY. COMP. CPU10FC 4-SHAFT (INCLUDES ITEMS 2 THRU 9)	1
2	64421	DRUM ONLY, 4-SHAFT, CPU10FC	1
3	84063	BUSHING, DRUM, HARDENED STL 3/4"ID	8
4	20120	CP406B SHAFT 3/4 X 11-3/8, 10" DRUM	4
5	64203	RETAINING PLATE (2-HALVES) 7-3/8"	1
6	64204	LOCKING PLATE (2-HALVES) 7-3/8"	1
7	10025	WASHER, FLAT 3/8 SAE ZINC	8
8	10811	WASHER, LOCK 3/8 ZINC	8
9	10912	SCREW, CAP 3/8-16 X 7/8 (GRADE 8)	8

NOTE:

CUTTER WHEELS AND SPACERS ARE NOT INCLUDED WITH THE DRUM ASSEMBLY. REFER TO CUTTER DRUM ASSEMBLY PROCEDURES FOR SUGGESTED SET-UPS AND QUANTITIES.

CUTTER WHEELS AND SPACERS			
			
3-1/8" 8 PT. CARBIDE CP408-TV PART # 20136	3" POINTED STEEL CP405-P PART # 20056	3" FLAT TIP STEEL CP405 PART # 20086	HARDENED STEEL SPACER 1-1/2"OD x 3/4"ID PART # 20060

ILLUSTRATION 12: 6-SHAFT CUTTER DRUM ASSEMBLY

E-CPU10FC-PL-1018

*NOTE: DRUMS ARE INTERCHANGABLE

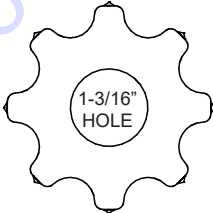
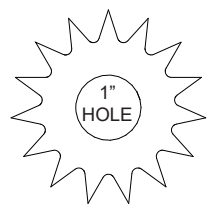
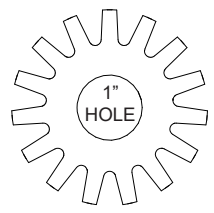
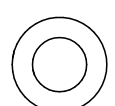
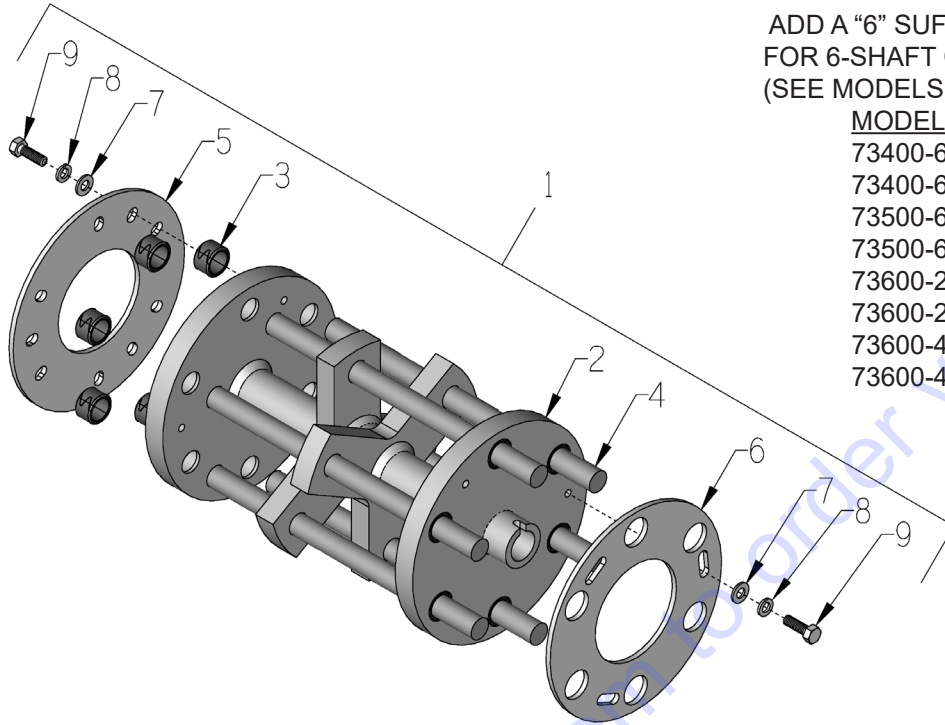

ADD A "6" SUFFIX TO SKU #
FOR 6-SHAFT CUTTER DRUM*.
(SEE MODELS LISTED BELOW)

MODELS:

- 73400-6
- 73400-6-R
- 73500-6
- 73500-6-R
- 73600-230-6
- 73600-230-6-R
- 73600-460-6
- 73600-460-6-R

ITEM #	PART #	DESCRIPTION	QTY.
1	64430	DRUM ASSY. COMP. CPU10FC 6-SHAFT (INCLUDES ITEMS 2 THRU 9)	1
2	64431	DRUM ONLY, 6-SHAFT, CPU10FC	1
3	84063	BUSHING, DRUM, HARDENED STL 3/4"ID	12
4	20120	CP406B SHAFT 3/4 X 11-3/8, 10" DRUM	4
5	64253	RETAINING PLATE, 6-SHAFT , CPU10FC	1
6	64254	LOCKING PLATE, 6-SHAFT , CPU10FC	1
7	10213	WASHER, FLAT 5/16 SAE ZINC	6
8	10801	WASHER, LOCK 5/16 ZINC	6
9	10806	SCREW, CAP 5/16-18 X 1	6

NOTE:

CUTTER WHEELS AND SPACERS ARE NOT INCLUDED WITH THE DRUM ASSEMBLY. REFER TO CUTTER DRUM ASSEMBLY PROCEDURES FOR SUGGESTED SET-UPS AND QUANTITIES.

CUTTER WHEELS AND SPACERS



2-1/4" 8 PT. CARBIDE
CP308T
PART # 20326



2-3/8" POINTED STEEL
CP404-P6
PART # 20296

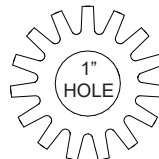

2-3/8" FLAT TIP STEEL
CP404
PART # 20076

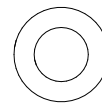

HARDENED
STEEL SPACER
1-1/2"OD x 3/4"ID
PART # 20060

PARTS FINDER

**Search Website
by Part Number**



**Search Manual
Library For Parts
Manual & Lookup Part
Numbers – Purchase
or Request Quote**

Search Manuals

Enter your information to help us find the right parts manual for your machine.

* Brand:

* Model:

* Serial:

* Part Number:

SEARCH

**Can't Find Part or
Manual? Request Help
by Manufacturer,
Model & Description**

Parts Order Form

Please fill in the following information to help us find the right part for your machine.

Manufacturer:	<input type="text"/>
Model:	<input type="text"/>
Description:	<input type="text"/>
Part Number:	<input type="text"/>
Quantity:	<input type="text"/>
Notes:	<input type="text"/>

Submit

Discount-Equipment.com is your online resource for quality parts & equipment.

Florida: **561-964-4949** Outside Florida TOLL FREE: **877-690-3101**

Need parts?

Click on this link: <http://www.discount-equipment.com/category/5443-parts/> and choose one of the options to help get the right parts and equipment you are looking for. Please have the machine model and serial number available in order to help us get you the correct parts. If you don't find the part on the website or on one of the online manuals, please fill out the request form and one of our experienced staff members will get back to you with a quote for the right part that your machine needs.

We sell worldwide for the brands: Genie, Terex, JLG, MultiQuip, Mikasa, Essick, Whiteman, Mayco, Toro Stone, Diamond Products, Generac Magnum, Airman, Haulotte, Barreto, Power Blanket, Nifty Lift, Atlas Copco, Chicago Pneumatic, Allmand, Miller Curber, Skyjack, Lull, Skytrak, Tsurumi, Husquvarna Target, Stow, Wacker, Sakai, Mi-T-M, Sullair, Basic, Dynapac, MBW, Weber, Bartell, Bennar Newman, Haulotte, Ditch Runner, Menegotti, Morrison, Contec, Buddy, Crown, Edco, Wyco, Bomag, Laymor, EZ Trench, Bil-Jax, F.S. Curtis, Gehl Pavers, Heli, Honda, ICS/PowerGrit, IHI, Partner, Imer, Clipper, MMD, Koshin, Rice, CH&E, General Equipment, Amida, Coleman, NAC, Gradall, Square Shooter, Kent, Stanley, Tamco, Toku, Hatz, Kohler, Robin, Wisconsin, Northrock, Oztec, Toker TK, Rol-Air, APT, Wylie, Ingersoll Rand / Doosan, Innovatech, Con X, Ammann, Mecalac, Makinex, Smith Surface Prep, Small Line, Wanco, Yanmar

ILLUSTRATION 13: DIAMOND GROOVING HEAD ASSEMBLY

OPTIONAL

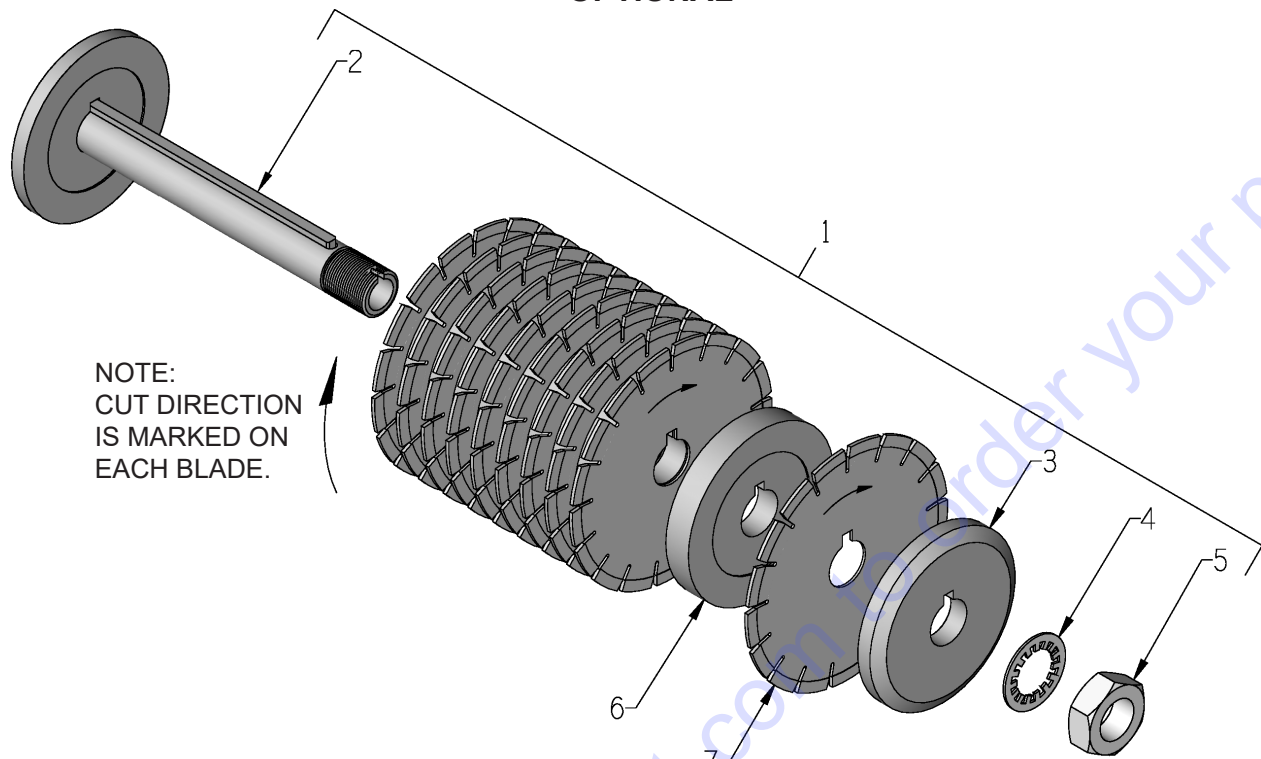

ITEM #	PART #	DESCRIPTION	QTY.
1	64440	HEAD ASSY., DIAMOND GROOVING, CPU10FC (INCLUDES ITEMS 2 THRU 5)	1
2	64441	ARBOR, DIAMOND GROOVING HEAD, CPU10FC	1
3	64303	ARBOR BLADE CAP 6"	1
4	64304	WASHER, LOCK, INT. TOOTH 1-1/2"	1
5	64305	NUT, HEX JAM 1 1/2-12	1
*6		SPACER, BLADE	*
	64306	6"OD X 1.5"ID X .063THK	
	64310	6"OD X 1.5"ID X .120THK	
	64307	6"OD X 1.5"ID X .430THK	
	64308	6"OD X 1.5"ID X .930THK	
	64312	6"OD X 1.5"ID X 1.156THK	
	64311	6"OD X 1.5"ID X 1.375THK	
*7		DIAMOND BLADES (1.5" HOLE W/ 3/8" KEYWAY)	*
	39807	8"DIA. X .090"THK	
	39851	8"DIA. X .125"THK	
	39810	8"DIA. X .250"THK	

***NOTE:**

BLADES & SPACERS ARE NOT INCLUDED. THE QUANTITIES VARY WITH THE TYPE OF SET-UP USED. OTHER SPACING IS AVAILABLE UPON REQUEST.

1/2 inch DIAMOND GROOVING HEAD SET-UPS

1/2" CENTER-TO-CENTER SPACING

(QTY. 20) 39807 .090"THK BLADES

(QTY. 19) 64307 .430"THK SPACERS

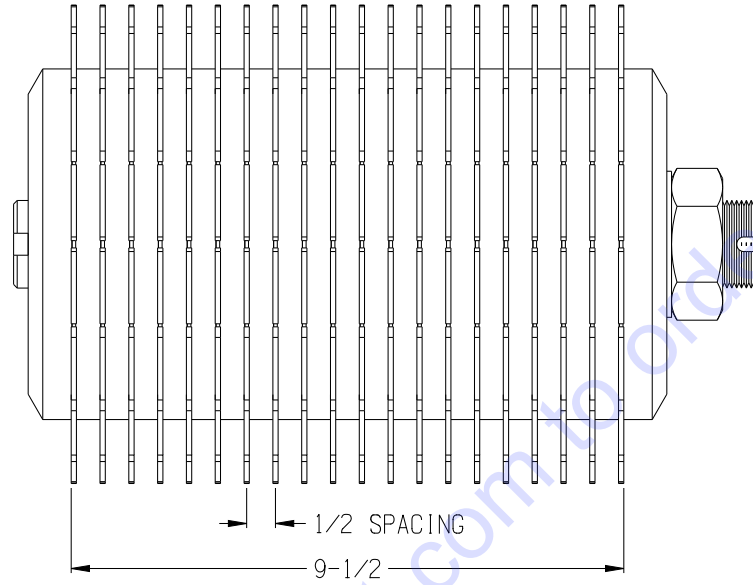

(QTY. 19) 39851 .125"THK BLADES

(QTY. 18) 64307 .430"THK SPACERS

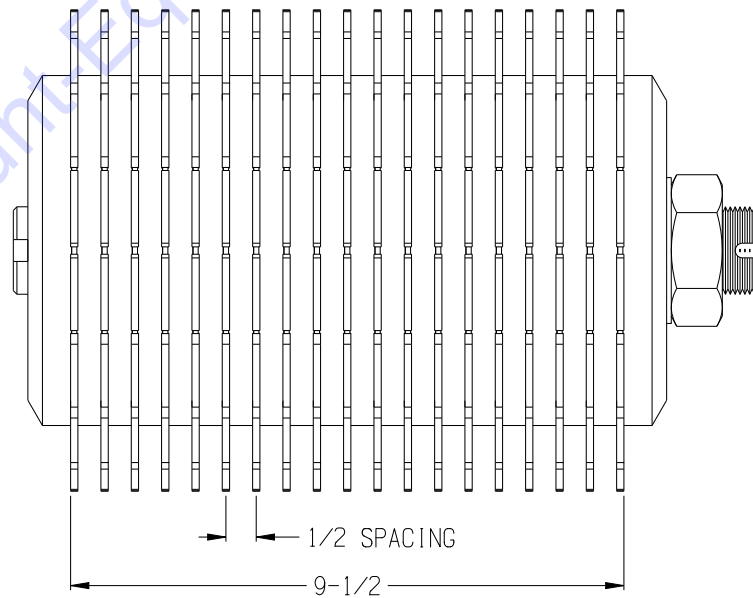

1 inch DIAMOND GROOVING HEAD SET-UPS

1" CENTER-TO-CENTER SPACING

(QTY. 10) 39807 .090"THK BLADES

(QTY. 9) 64308 .930"THK SPACERS

(QTY. 1) 64307 .430"THK SPACER

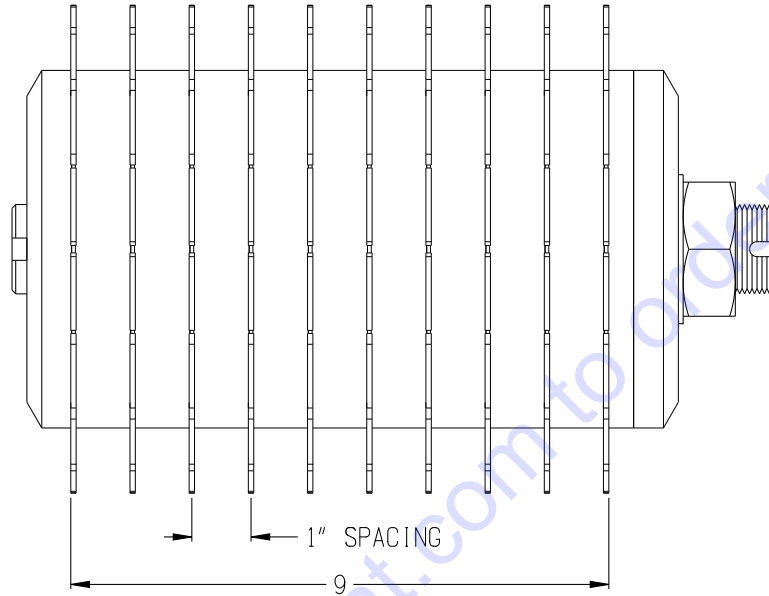

(QTY. 10) 39851 .125"THK BLADES

(QTY. 9) 64308 .930"THK SPACERS

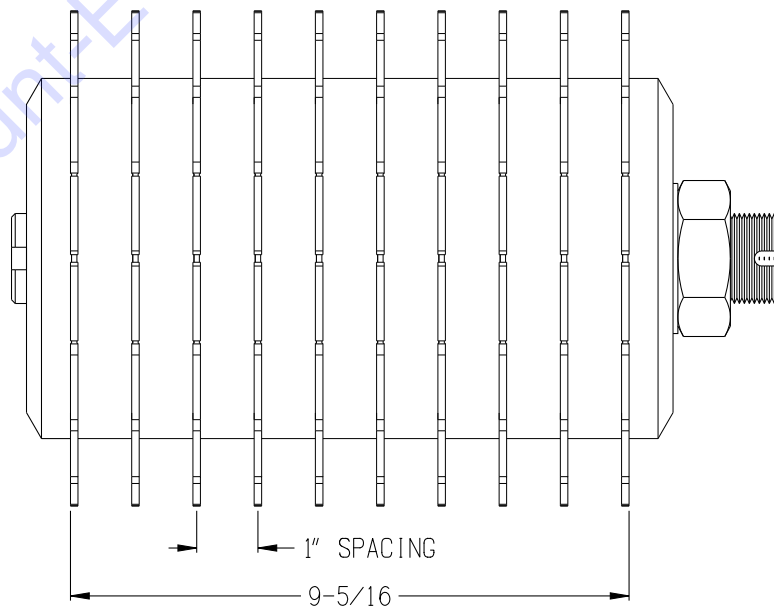

DIAMOND GROOVING HEAD SET-UPS CONTINUED

A few more set-ups examples are shown below.
Other custom set-ups can be created per request.

(QTY. 8) 39810 .25"THK BLADES

(QTY. 7) 64312 1.156"THK SPACERS

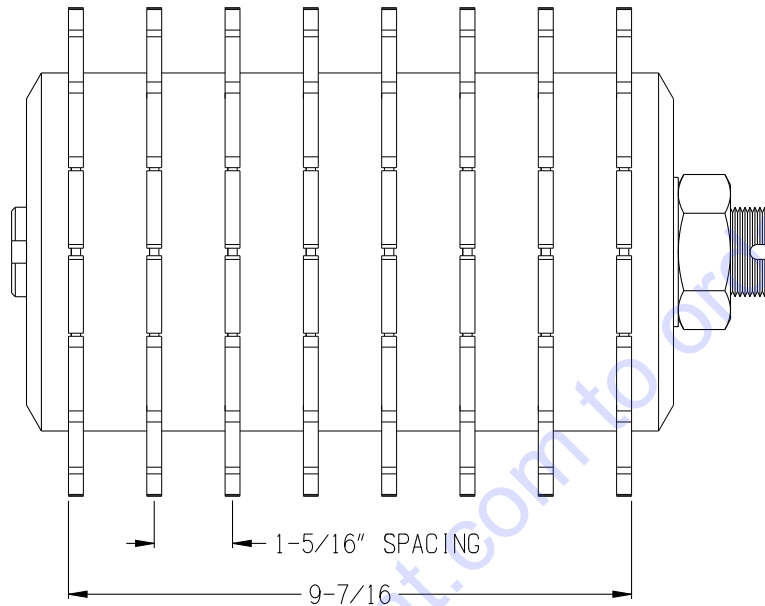

(QTY. 12) 39810 .25"THK BLADES

(QTY. 6) 64310 .120"THK SPACERS (BETWEEN BLADES)

(QTY. 5) 64312 1.375"THK SPACERS

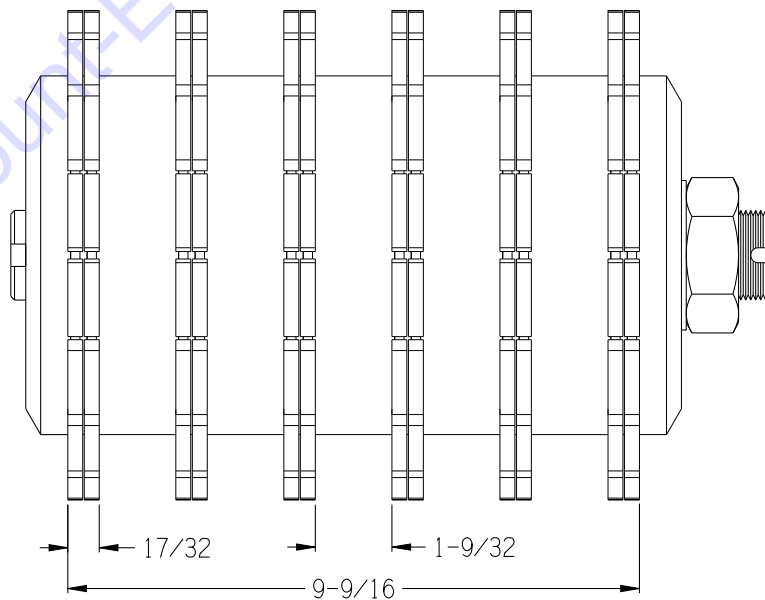
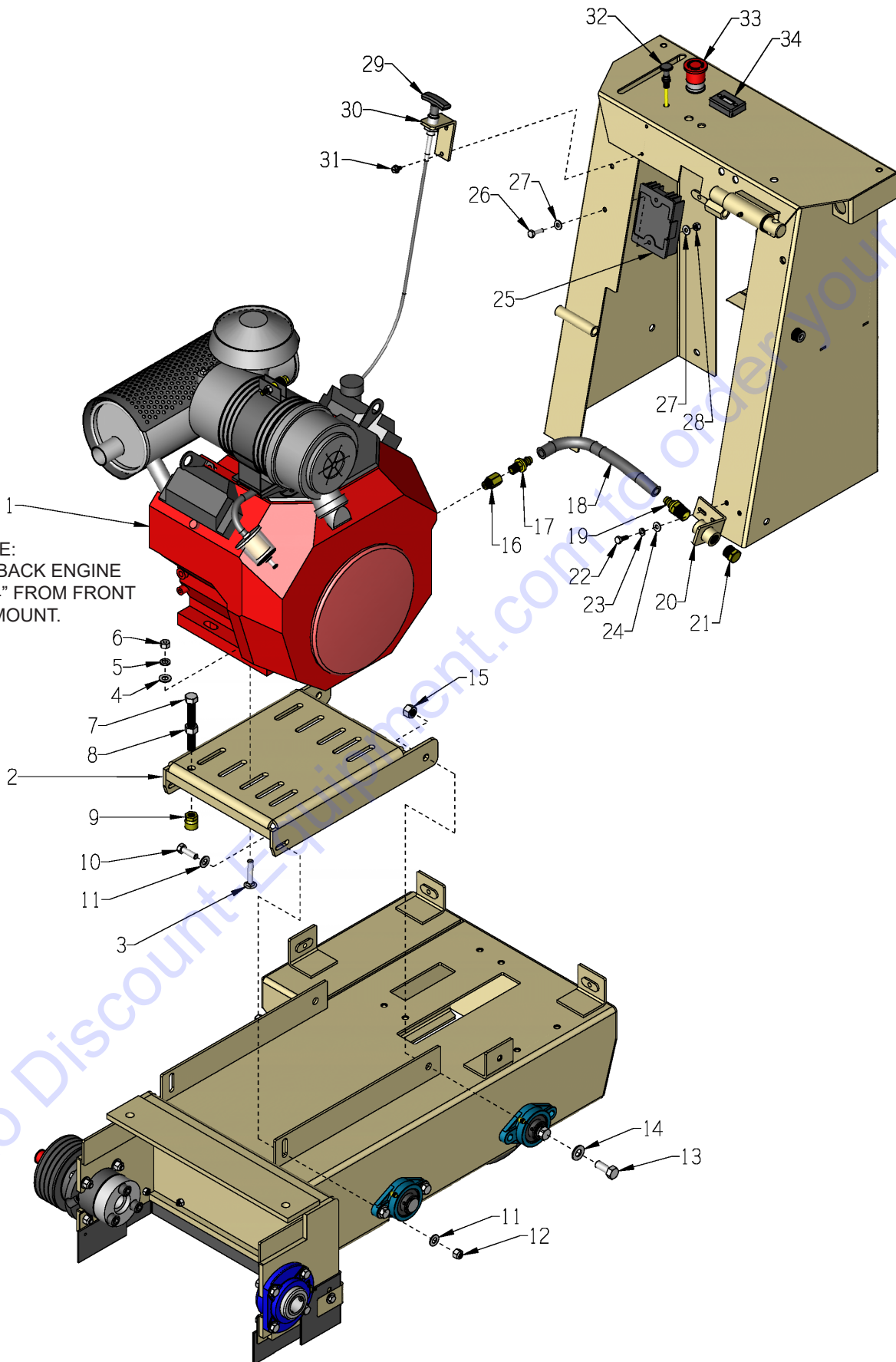

ILLUSTRATION 14: ENGINE GROUPING FOR HONDA GX630

NOTE:
SETBACK ENGINE
1-3/4" FROM FRONT
OF MOUNT.



**PARTS LISTING - ILLUSTRATION 14:
ENGINE GROUPING FOR HONDA GX630**

ITEM #	PART #	DESCRIPTION	QTY.
1	15080	ENGINE, HONDA GX630RHTXF2	1
	15253	REPLACEMENT PARTS: SWITCH ASSY., IGN., HONDA GX630/690 (INCLUDES 2 KEYS)	1
	15080-1	KEY, IGNITION (2 PACK), HONDA 35110-ZV5-V50	1
	15246	MUFFLER, HONDA V2MFLRHIR	1
	15247	AIR CLEANER/FILTER, HONDA DNLS5	1
	15247-1	ELEMENT 5", DONALDSON AIR FILTER, HONDA 17210-Z6L-P821575	1
2	64017	MOUNT, ENGINE/MOTOR, CPU-10	1
3	10917	BOLT, CARRIAGE 3/8-16 X 2	4
4	10025	WASHER, FLAT 3/8 SAE ZINC	4
5	10811	WASHER, LOCK 3/8 ZINC	4
6	10404	NUT, HEX 3/8-16 ZINC	4
7	10392	BOLT, TAP 1/2-13 X 4 (FULL THREAD)	1
8	10417	NUT, HEX 1/2-13 ZINC	1
9	50710	TOGGLE PAD 7/8"D X 15/16"H X 1/2-13	1
10	10309	SCREW, CAP 3/8-24 X 1-1/4 ZINC	2
11	10025	WASHER, FLAT 3/8 SAE ZINC	4
12	10152	NUT, HEX NYLON LOCK 3/8-24 ZINC	2
13	10321	SCREW, CAP 1/2-20 X 1-1/4	2
14	10312	WASHER, FLAT 1/2 SAE ZINC	2
15	10154	NUT, HEX NYLON LOCK 1/2-20 ZINC	2
16	11689	ADAPTER, 20MM X 1.5 TO 1/4FPT	1
17	11579	BARB, PUSH-ON 1/2HOSE X 1/4 MPT	1
18	64057	HOSE, PUSH-ON 1/2"ID X 10-1/2"L	1
19	80061	BARB, PUSH-ON 1/2HOSE X 1/2MPT	1
20	57159	BRACKET, OIL DRAIN	1
21	50552	PIPE PLUG 1/2 NPT (BRASS)	1
22	10018	SCREW, CAP 1/4-20 X 3/4	2
23	10038	WASHER, LOCK 1/4 ZINC	2
24	10602	WASHER, FLAT 1/4 SAE ZINC	2
25	N/A*	REGULATOR RECTIFIER 20A - HONDA 31750-Z2E-803 *SEE YOUR LOCAL HONDA PARTS DEALER FOR REPLACEMENT.	1
26	10031	SCREW, CAP 1/4-20 X 1	2
27	10602	WASHER, FLAT 1/4 SAE ZINC	4
28	10154	NUT, HEX NYLON LOCK 1/2-20 ZINC	2
29	51081	CABLE, TURN-TO-LOCK CONTROL 72" (CUT HOUSING TO 54")	1
30	64075	MOUNT BRKT., THROTTLE CABLE	1
31	10846	SCREW, CAP STSHW 1/4-20 X 1/2	2
32	15129	CABLE, CHOKE CONTROL 72" (CUT HOUSING TO 58")	1
33	15275-R	SWITCH, E-STOP W/ RED N.C. CONTACT INCLUDES:	1
	15275	PUSHBUTTON, TURN TO RELEASE E-STOP	1
	15276	MOUNTING ADAPTER, PUSHBUTTON	1
	15278	CONTACT ELEMENT, NC RED LM2TC01	1
34	15138	HOUR METER, INDUCTIVE	1

MODEL CPU10FC-20H

ILLUSTRATION 15:
FUEL TANK GROUPING FOR HONDA GX630

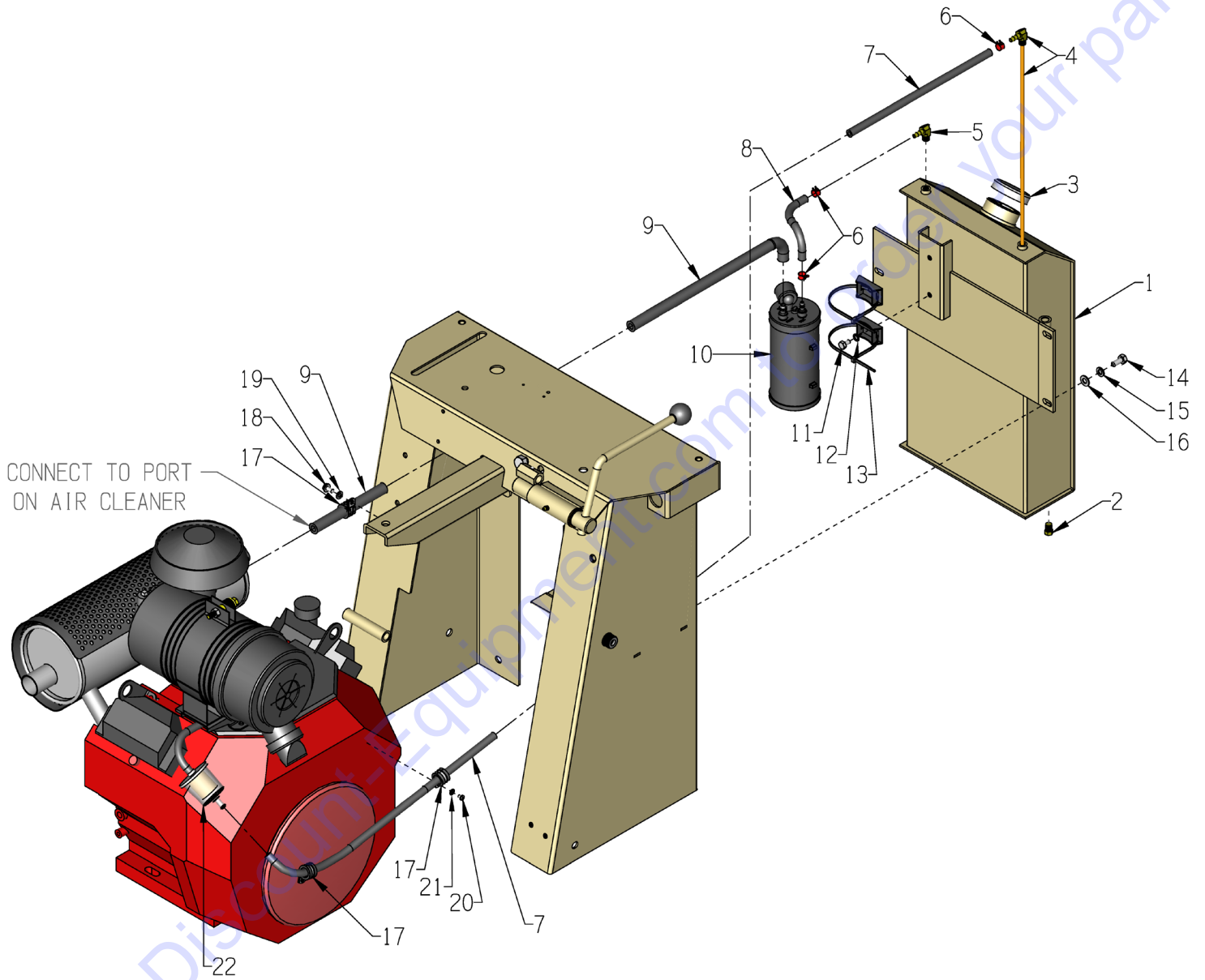

PARTS LISTING

ILLUSTRATION 15: FUEL TANK GROUPING FOR HONDA GX630

ITEM #	PART #	DESCRIPTION	QTY.
1	64014	TANK, FUEL 3 GAL., CPU-10	1
2	11650	PIPE PLUG 1/8 NPT BRASS (INCLUDED W/ ITEM 1 - FUEL TANK)	1
3	61081	CAP, FUEL TANK W/ VITON GASKET (INCLUDES TEATHER CHAIN)	1
4	61058	TUBE, FUEL PICK-UP 19"	1
5	10771	BARB ELBOW 90, 1/4HOSE X 1/8MPT	1
6	10763	CLAMP, HOSE, SPRING-BAND 7/16"	4
7	10948	TUBING, EVAP LOW PERM. FUEL 1/4"ID X 54" (BULK P/N 10948)	4-1/2 FT.
8	10948	TUBING, EVAP LOW PERM. FUEL 1/4"ID X 6" (BULK P/N 10948)	1/2 FT.
9	15256	TUBING, EVAP LOW PERM. FUEL 3/8"ID X 36" (BULK P/N 15256)	3 FT.
10	51297	CANISTER, CARBON 468888A FOR HONDA (INCLUDES 2 MOUNTING PADS)	1
11	10834	SCREW, CAP 1/4-20 X 1/2 ZINC	2
12	10451	WASHER, LOCK, INT. TOOTH 1/4"	2
13	10982	TIE, CABLE, BLACK NYLON 11-1/4"	2
14	10053	SCREW, CAP 5/16-18 X 3/4	3
15	10801	WASHER, LOCK 5/16 ZINC	3
16	10213	WASHER, FLAT 5/16 SAE ZINC	3
17	11565	CLAMP, LOOM, 5/8" (SAE SIZE 10)	3
18	10846	SCREW, CAP STSHW 1/4-20 X 1/2	1
19	10038	WASHER, LOCK 1/4 ZINC	1
20	10858	SCREW, SHEET METAL #10 X 1/2	2
21	10831	WASHER, LOCK, INT. TOOTH #10	2
22	N/A*	FUEL FILTER/STRAINER - HONDA P/N 16910-Z6L-003 *SEE YOUR LOCAL HONDA PARTS DEALER FOR REPLACEMENT.	1

MODEL CPU10FC-20H

ILLUSTRATION 16: BATTERY GROUPING

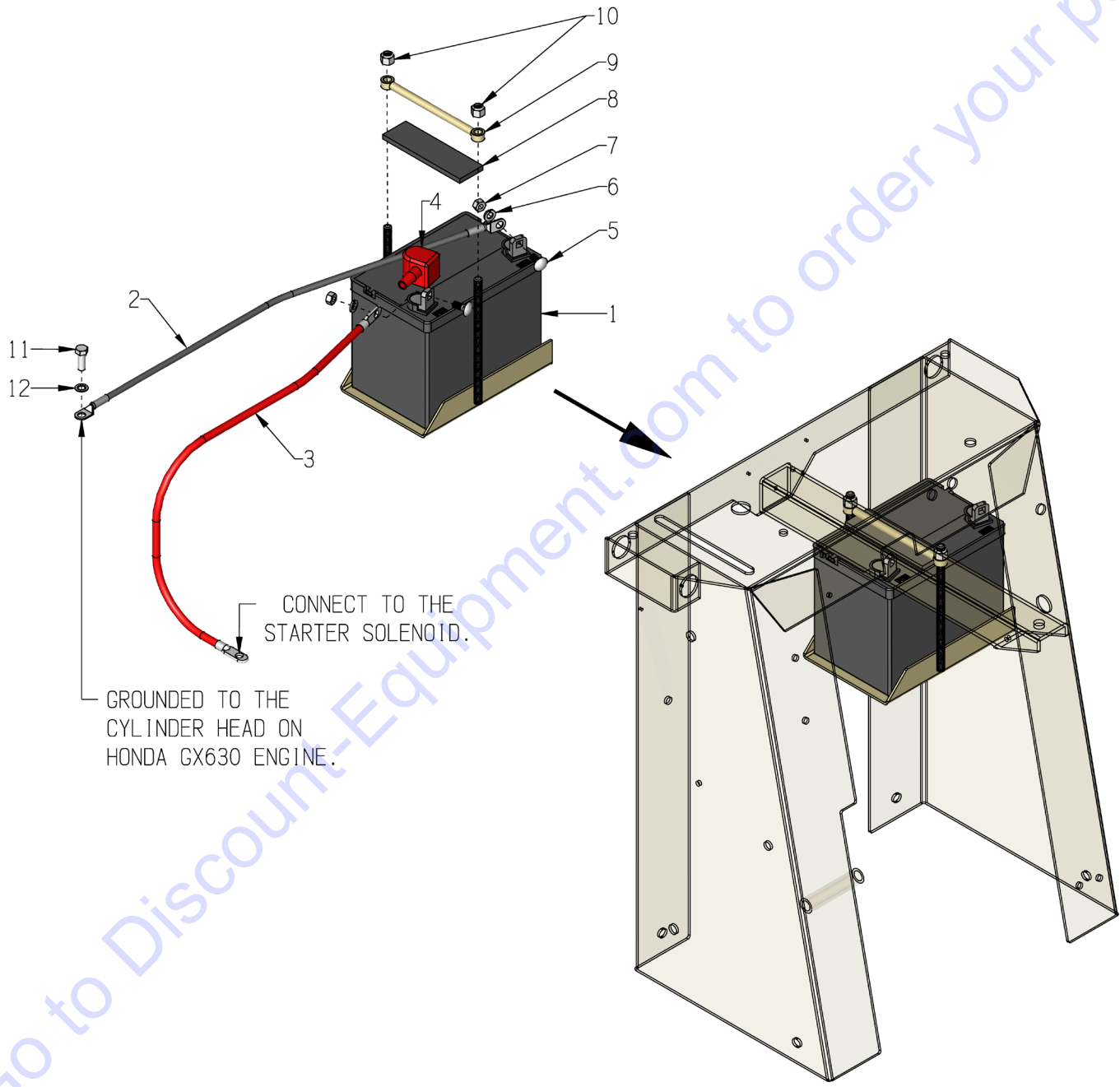

Go to Discount-Equipment.com to order your parts

PARTS LISTING

ILLUSTRATION 16: BATTERY GROUPING

ITEM #	PART #	DESCRIPTION	QTY.
1	84011*	BATTERY 12 VOLT/300 CCA INTERSTATE BATTERIES P/N SP-35* *SEE YOUR LOCAL DEALER FOR REPLACEMENT.	1
2	50117B	CABLE, EYE-EYE 4GA. X 24" (BLACK)	1
3	50117R	CABLE, EYE-EYE 4GA. X 24" (RED)	1
4	11583	INSULATOR, BAT.TERM. U-1 STYLE(RED)	1
5	10818	BOLT, CARRIAGE 5/16-18 X 3/4	2
6	10801	WASHER, LOCK 5/16 ZINC	2
7	10054	NUT, HEX 5/16-18 ZINC	2
8	64049	PAD, RBR 2-1/2 X 1-1/2 X 1/4, CPU10	1
9	64008	CLAMP, BATTERY HOLD DOWN, CPU-10	1
10	10156	NUT, HEX NYLON LOCK 3/8-16 ZINC	2
11	77263	SCREW, CAP M8-1.25 X 25MM	1
12	10452	WASHER, LOCK, INT. TOOTH 5/16"	1

ILLUSTRATION 17: ENGINE GROUPING FOR HONDA GX390

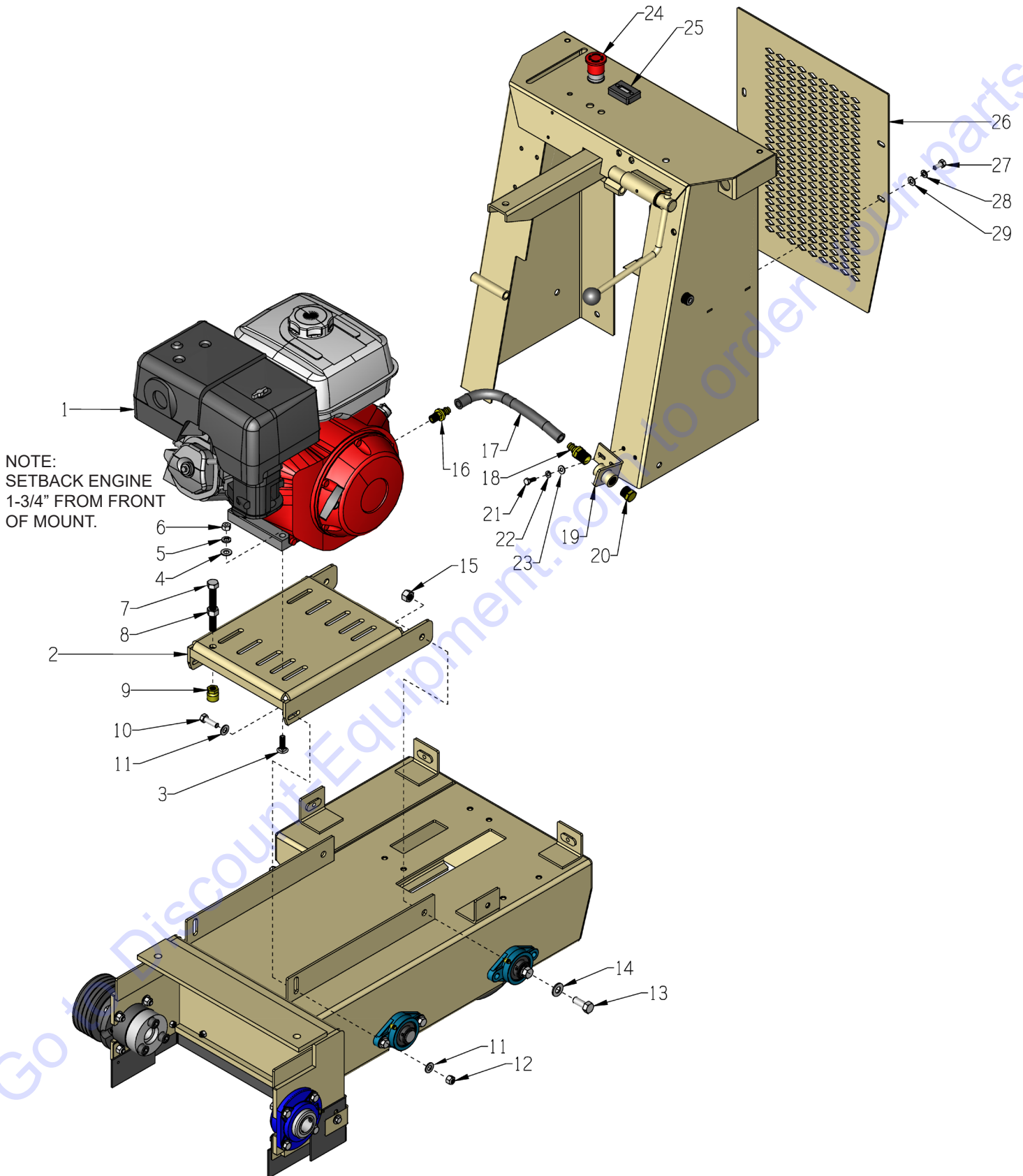

**PARTS LISTING - ILLUSTRATION 17:
ENGINE & MOUNT GROUPING FOR HONDA GX390**

ITEM #	PART #	DESCRIPTION	QTY.
1	15029	ENGINE, HONDA GX390UT2QC9 CYC.AC	1
2	64017	MOUNT, ENGINE/MOTOR, CPU-10	1
3	10087	BOLT, CARRIAGE 3/8-16 X 1-3/4	4
4	10025	WASHER, FLAT 3/8 SAE ZINC	4
5	10811	WASHER, LOCK 3/8 ZINC	4
6	10404	NUT, HEX 3/8-16 ZINC	4
7	10392	BOLT, TAP 1/2-13 X 4 (FULL THREAD)	1
8	10417	NUT, HEX 1/2-13 ZINC	1
9	50710	TOGGLE PAD 7/8"D X 15/16"H X 1/2-13	1
10	10309	SCREW, CAP 3/8-24 X 1-1/4 ZINC	2
11	10025	WASHER, FLAT 3/8 SAE ZINC	4
12	10152	NUT, HEX NYLON LOCK 3/8-24 ZINC	2
13	10321	SCREW, CAP 1/2-20 X 1-1/4	2
14	10312	WASHER, FLAT 1/2 SAE ZINC	2
15	10154	NUT, HEX NYLON LOCK 1/2-20 ZINC	2
16	11542	BARB, PUSH-ON 3/8HOSE X M12-1.5MALE	1
17	64068	HOSE, PUSH-ON 3/8"ID X 12"L	1
18	11580	BARB, PUSH-ON 3/8HOSE X 1/2MPT	1
19	57159	BRACKET, OIL DRAIN	1
20	50552	PIPE PLUG 1/2 NPT (BRASS)	1
21	10018	SCREW, CAP 1/4-20 X 3/4	2
22	10038	WASHER, LOCK 1/4 ZINC	2
23	10602	WASHER, FLAT 1/4 SAE ZINC	2
24	15275-G	SWITCH, E-STOP W/ GREEN N.O. CONTACT INCLUDES:	1
	15275	PUSHBUTTON, TURN TO RELEASE E-STOP	1
	15276	MOUNTING ADAPTER, PUSHBUTTON	1
	15277	CONTACT ELEMENT, NO GREEN LM2TC10	1
25	15138	HOUR METER, INDUCTIVE (OPTIONAL)	1
26	64066	GRILLE, REAR, CPU-10	1
27	10806	SCREW, CAP 5/16-18 X 1	3
28	10801	WASHER, LOCK 5/16 ZINC	3
29	10213	WASHER, FLAT 5/16 SAE ZINC	3

MODEL CPU10FC-10B

ILLUSTRATION 18: MOTOR GROUPING FOR ELECTRIC MODELS

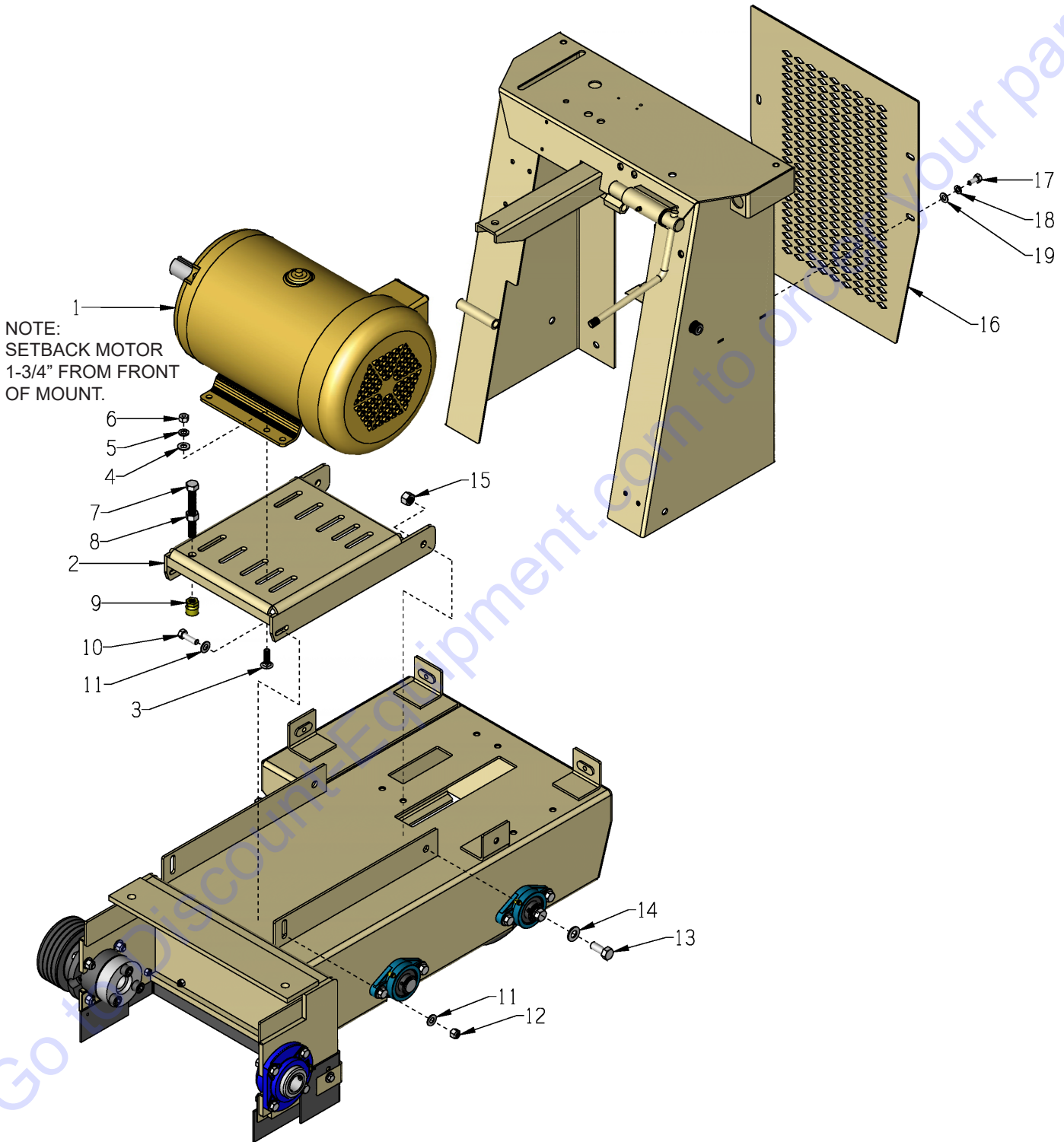

**PARTS LISTING - ILLUSTRATION 18:
MOTOR GROUPING FOR ELECTRIC MODELS**

ITEM #	PART #	DESCRIPTION	QTY.
1	16004	MOTOR, BALDOR 10HP-3PH 60HZ 3450RPM	1
2	64017	MOUNT, ENGINE/MOTOR, CPU-10	1
3	10802	BOLT, CARRIAGE 3/8-16 X 1 ZINC	4
4	10025	WASHER, FLAT 3/8 SAE ZINC	4
5	10811	WASHER, LOCK 3/8 ZINC	4
6	10404	NUT, HEX 3/8-16 ZINC	4
7	10392	BOLT, TAP 1/2-13 X 4 (FULL THREAD)	1
8	10417	NUT, HEX 1/2-13 ZINC	1
9	50710	TOGGLE PAD 7/8"D X 15/16"H X 1/2-13	1
10	10309	SCREW, CAP 3/8-24 X 1-1/4 ZINC	2
11	10025	WASHER, FLAT 3/8 SAE ZINC	4
12	10152	NUT, HEX NYLON LOCK 3/8-24 ZINC	2
13	10321	SCREW, CAP 1/2-20 X 1-1/4	2
14	10312	WASHER, FLAT 1/2 SAE ZINC	2
15	10154	NUT, HEX NYLON LOCK 1/2-20 ZINC	2
16	64066	GRILLE, REAR, CPU-10	1
17	10806	SCREW, CAP 5/16-18 X 1	3
18	10801	WASHER, LOCK 5/16 ZINC	3
19	10213	WASHER, FLAT 5/16 SAE ZINC	3

ILLUSTRATION 19: STARTER & TRANSFORMER BOX GROUPING

NOTE:
SEE PAGE 47 FOR CORDS CONNECTING
THE STARTER, THE TRANSFORMER, THE
MOTOR AND THE SAFETY SWITCHES.

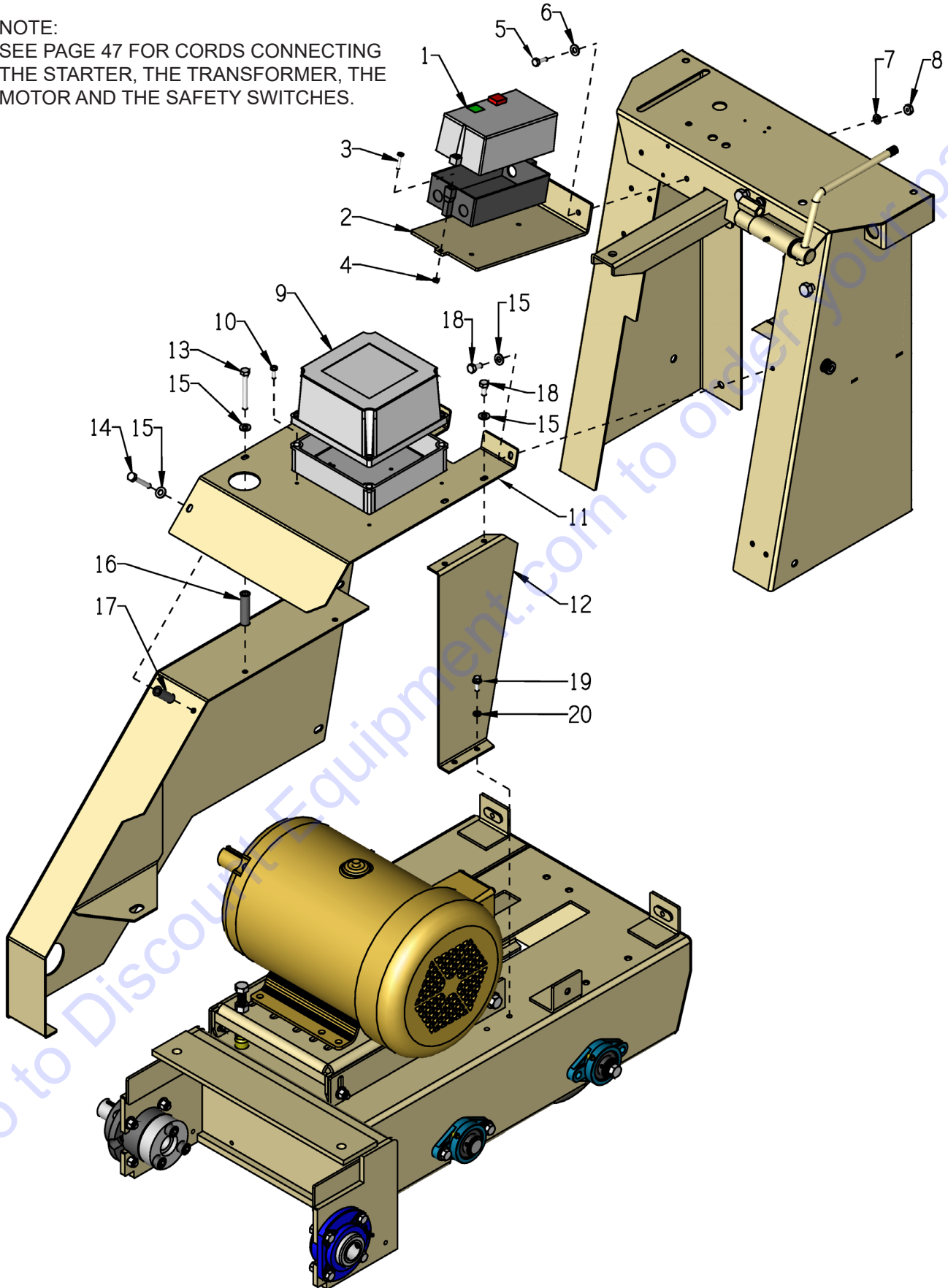

PARTS LISTING - ILLUSTRATION 19: STARTER & TRANSFORMER BOX GROUPING			
ITEM #	PART #	DESCRIPTION	QTY.
1	16450	STARTER ACI #128864 START-STOP 24V 21-25A (230V)	1
	16447	STARTER ACI #128857-24 START-STOP 24V 9-12.5A (460V)	1
		REPLACEMENT PARTS:	
	16652	STARTER BOX ONLY HNFS18-20	1
	16615	STARTER CONT./COIL ACI SK18.310-24	1
	16620	STARTER AC COIL 24V-60/50HZ	1
	16638	STARTER OVERLOAD RELAY 21-25 AMP	1
	16634	STARTER OVERLOAD RELAY 9.0-12.5 AMP	1
2	64411	BRACKET, ACI STARTER, CPU10	1
3	11732	SCREW, MACHINE 10-32 X 1-3/4 RHP	2
	10384	SCREW, MACHINE 10-32 X 1 RHP	1
4	10832	NUT, KEPS LOCK 10-32 ZINC	3
5	10053	SCREW, CAP 5/16-18 x 3/4	2
6	10213	WASHER, FLAT 5/16 SAE ZINC	2
7	10801	WASHER, LOCK 5/16 ZINC	2
8	10054	NUT, HEX 5/16-18 ZINC	2
9	16500	TRANSFORMER W/ BOX COMPLETE	1
		REPLACEMENT PARTS:	
	16501	ENCLOSURE, NEMA 4X, 7 X 7 X 6	1
	16502	PLATE, TRANSFORMER 5.8" X 5.8"	1
	16150	TRANSFORMER 75VA 240/480P.V.-24S.V.	1
	16504	FUSE, MIDGET 600VAC, 5 AMP	1
	16505	FUSE BLOCK, SINGLE POLE W/ BOX LUGS	1
16506	SCREW, SHEET METAL 8 X 3/8 TRUSS HD	12	
10	10362	SCREW, MACHINE 8-32 X 3/4	4
	10875	WASHER, FLAT #8 SAE	4
	10462	NUT, KEPS LOCK 8-32 ZINC	4
11	64062	SHROUD, MOTOR, CPU-10	1
12	64063	SHROUD SIDE PANEL, MOTOR, CPU-10	1
13	11658	SCREW, CAP 1/4-20 X 2-3/4	2
14	10398	SCREW, CAP 1/4-20 X 2	1
15	10602	WASHER, FLAT 1/4 SAE ZINC	6
16	64078	SPACER, STEEL 5/8"OD X 3/8"ID X 2-1/4"L	2
17	64079	SPACER, STEEL 5/8OD X 3/8ID X 1-5/8"L	1
18	10018	SCREW, CAP 1/4-20 X 3/4	3
19	10846	SCREW, CAP STSHW 1/4-20 X 1/2	2
20	10038	WASHER, LOCK 1/4 ZINC	2

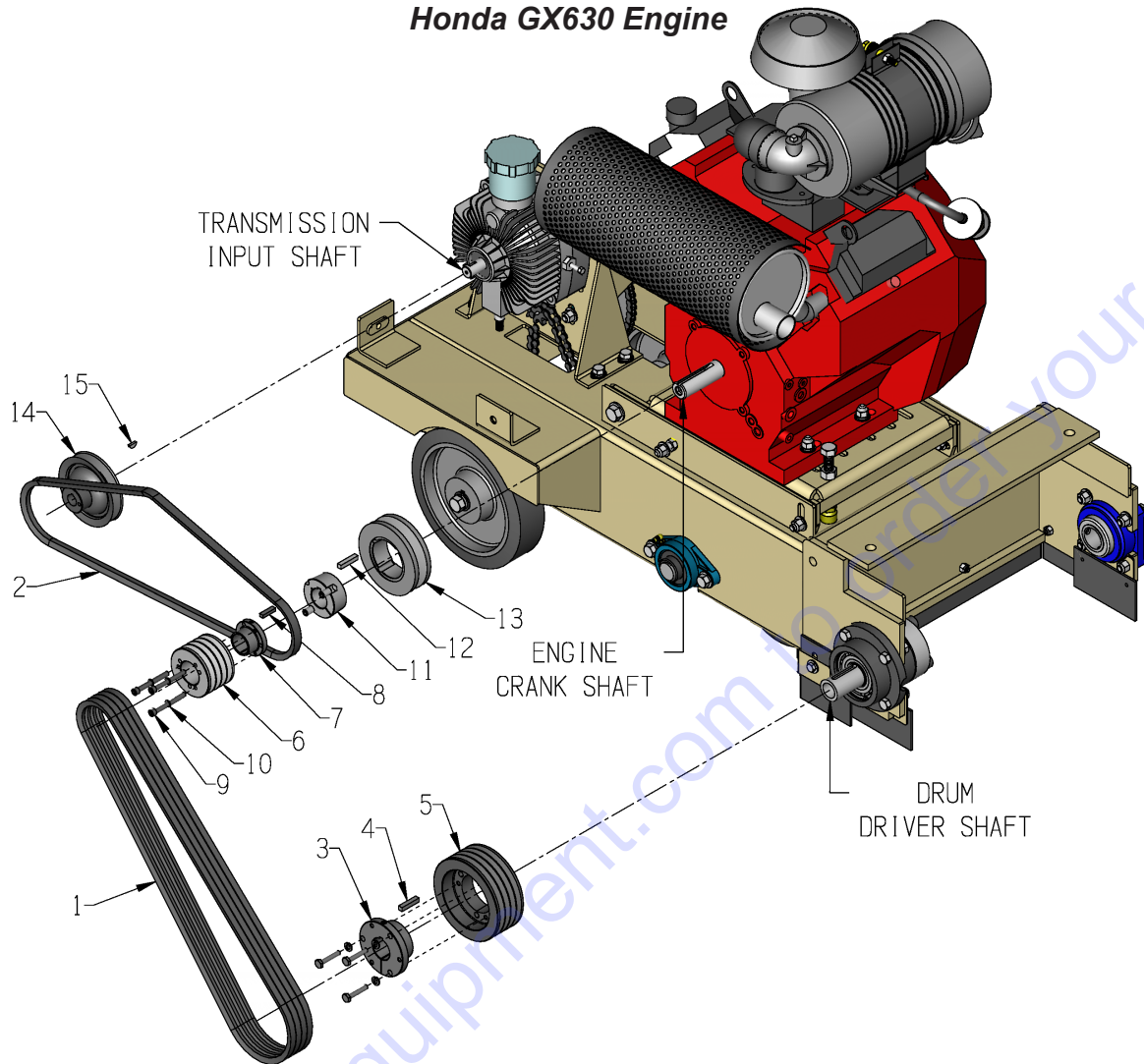
ILLUSTRATION 20: BELT DRIVE GROUPING**Honda GX630 Engine**

ITEM #	PART #	DESCRIPTION	QTY.
1	10235	BELT 3VX-475	4
2	10218	BELT 4L-450 OR A43	1
3	10064	BUSHING, SHEAVE SDS X 1-1/4"BORE (INCL: HARDWARE & KEY)	1
4	10305	KEY 1/4SQ X 1-1/4	1
5	64038	SHEAVE 4.75"OD X 4GR.3V X SDS	1
6	64037	SHEAVE 2.8"OD X 4GR.3V X JA	1
7	10533	BUSHING, SHEAVE JA X 1-1/8"BORE	1
8	10179	KEY 1/4 X 3/16 X 1	1
9	10159	SCREW, SKT.HD.CAP 10-24X2-1/4 ALLOY	3
10	10831	WASHER, LOCK, INT. TOOTH #10	3
11	10529	BUSHING, SHEAVE TAPER-LOCK 1-1/8"B	1
12	10174	KEY 1/4SQ X 1	1
13	10528	SHEAVE 4.15"OD X 1GR.AB X TPR-LOCK	1
14	50062	SHEAVE, TRANS. 4"OD X 1GR. X .671"B	1
15	50071	KEY, WOODRUFF 1/8 X 1/2 (SAE #3)	1

ILLUSTRATION 21: BELT DRIVE GROUPING

Honda GX390 Engine

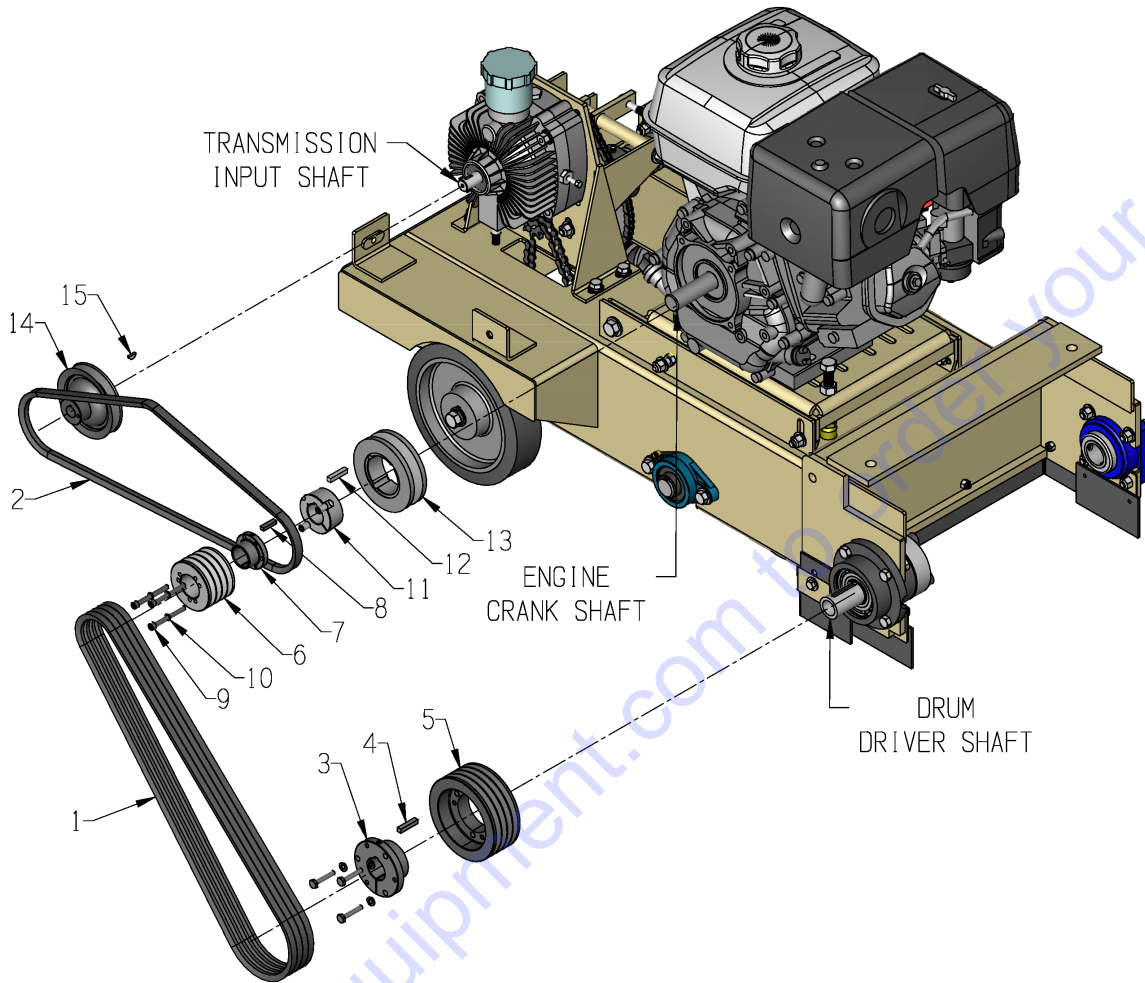

ITEM #	PART #	DESCRIPTION	QTY.
1	10235	BELT 3VX-475	4
2	10218	BELT 4L-450 OR A43	1
3	10064	BUSHING, SHEAVE SDS X 1-1/4"BORE (INCL: HARDWARE & KEY)	1
4	10305	KEY 1/4SQ X 1-1/4	1
5	64038	SHEAVE 4.75"OD X 4GR.3V X SDS	1
6	64037	SHEAVE 2.8"OD X 4GR.3V X JA	1
7	10557	BUSHING, SHEAVE JA X 1" BORE	1
8	10174	KEY 1/4SQ X 1	1
9	10159	SCREW, SKT.HD.CAP 10-24X2-1/4 ALLOY	3
10	10831	WASHER, LOCK, INT. TOOTH #10	3
11	10544	BUSHING, SHEAVE TAPER-LOCK 1"BORE	1
12	10174	KEY 1/4SQ X 1	1
13	10528	SHEAVE 4.15"OD X 1GR.AB X TPR-LOCK	1
14	50062	SHEAVE, TRANS. 4"OD X 1GR. X .671"B	1
15	50071	KEY, WOODRUFF 1/8 X 1/2 (SAE #3)	1

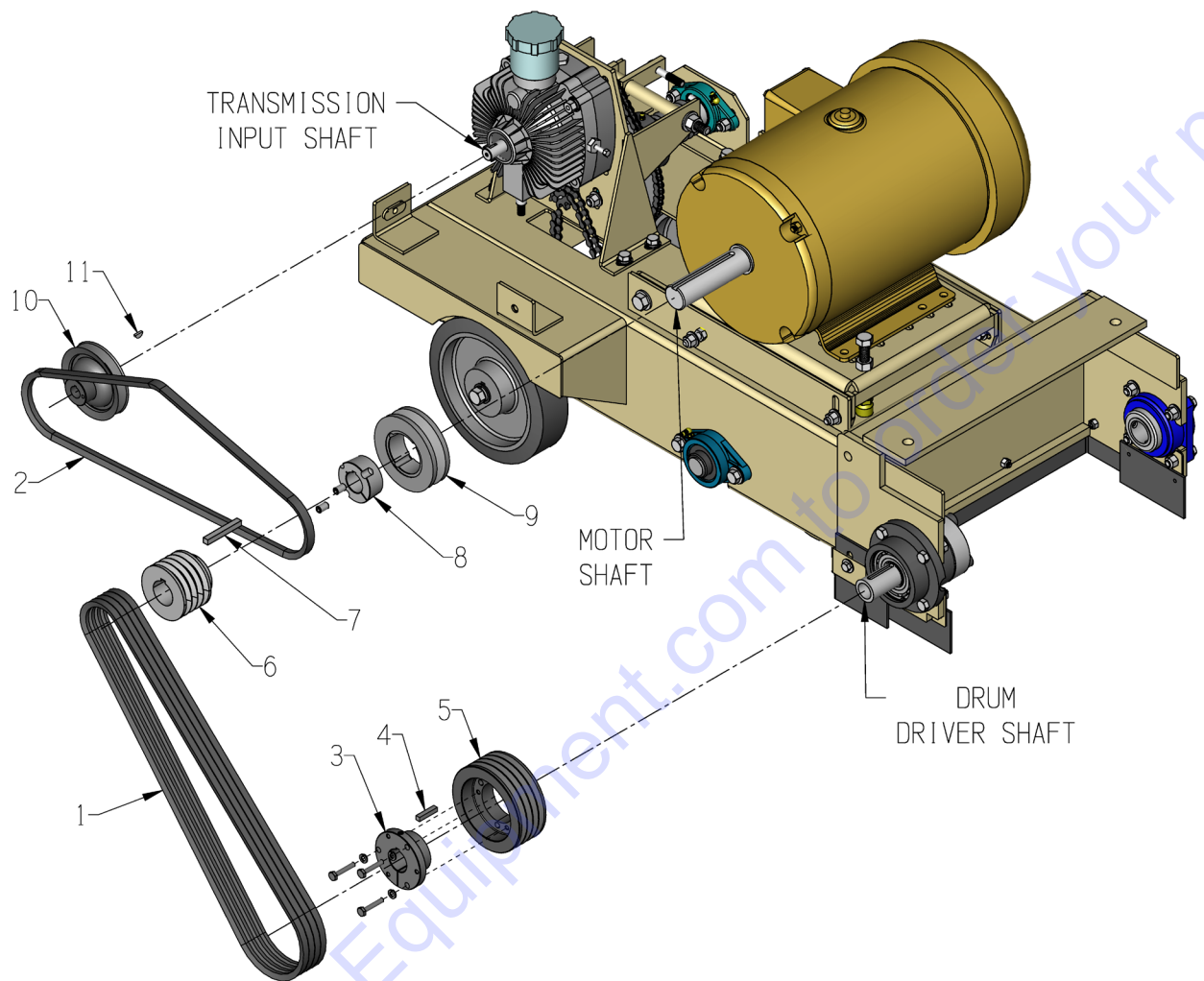
ILLUSTRATION 22: BELT DRIVE GROUPING**BALDOR 10 HP Motor**

ITEM #	PART #	DESCRIPTION	QTY.
1	10235	BELT 3VX-475	4
2	10218	BELT 4L-450 OR A43	1
3	10064	BUSHING, SHEAVE SDS X 1-1/4\"BORE (INCL: HARDWARE & KEY)	1
4	10305	KEY 1/4SQ X 1-1/4	1
5	64038	SHEAVE 4.75\"OD X 4GR.3V X SDS	1
6	64069	SHEAVE 3\"OD X 4GR.3V X 1-3/8\"BORE	1
7	-----	KEY 5/16\"SQ. X 2-3/8 (INCLUDED W/ MOTOR)	1
8	10537	BUSHING, SHEAVE TAPER-LOCK 1-3/8\"BORE	1
9	10528	SHEAVE 4.15\"OD X 1GR.AB X TPR-LOCK	1
10	50062	SHEAVE, TRANS. 4\"OD X 1GR. X .671\"B	1
11	50071	KEY, WOODRUFF 1/8 X 1/2 (SAE #3)	1

ILLUSTRATION 23: IDLER ARM GROUPING FOR TRANSMISSION BELT

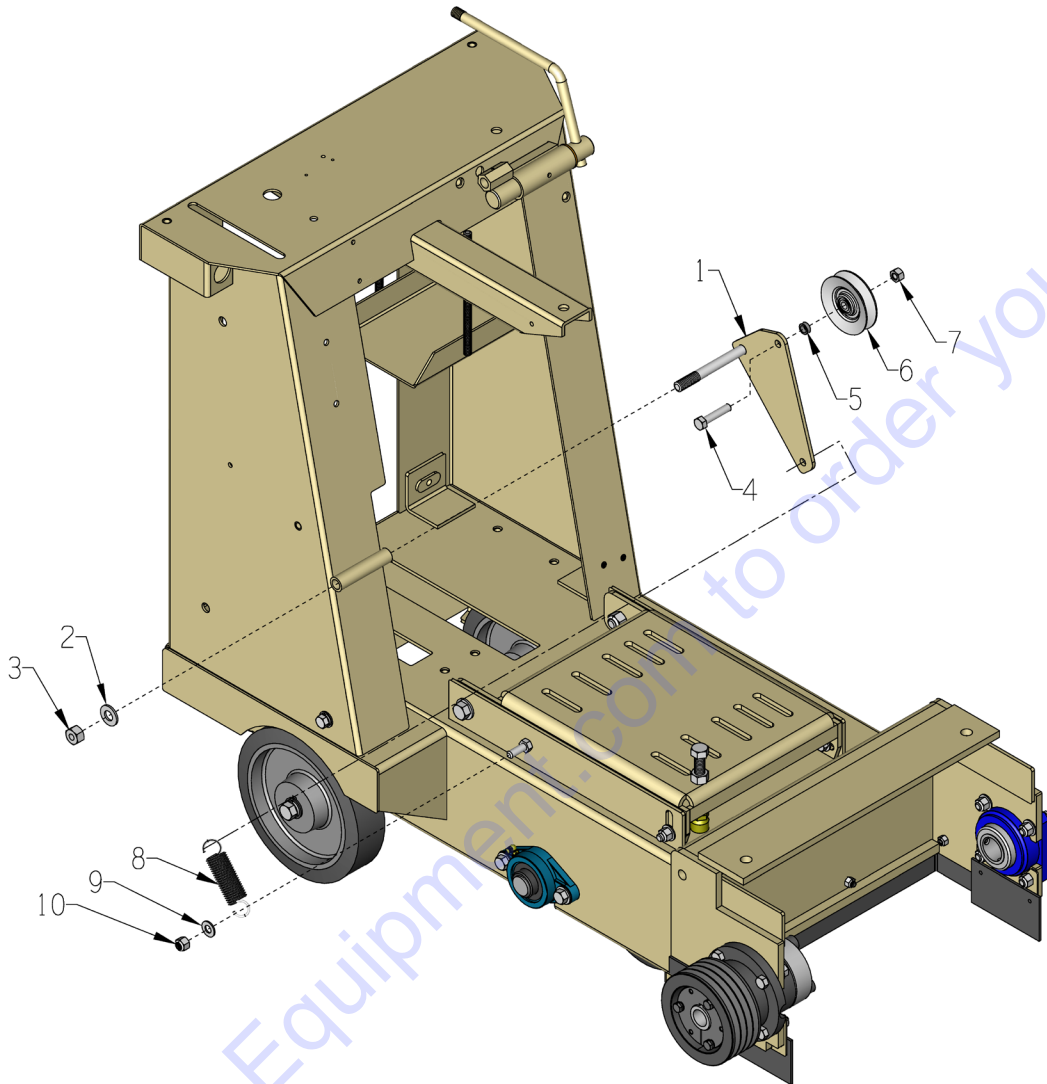

ITEM #	PART #	DESCRIPTION	QTY.
1	64019	BRACKET, IDLER, CPU-10	1
2	10312	WASHER, FLAT 1/2 SAE ZINC	1
3	10155	NUT, HEX NYLON LOCK 1/2-13 ZINC	1
4	10029	SCREW, CAP 3/8-24 X 1-3/4	1
5	10113	SPACER, STEEL 9/16OD X 3/8ID X 7/32	1
6	50115	IDLER PULLEY 3"OD X 1GR.AB X 3/8"B	1
7	10152	NUT, HEX NYLON LOCK 3/8-24 ZINC	1
8	50074	SPRING, EXT. 1"OD X 3-15/16	1
9	10025	WASHER, FLAT 3/8 SAE ZINC	1
10	10156	NUT, HEX NYLON LOCK 3/8-16 ZINC	1

WIRING DIAGRAM FOR HONDA GX630

COLOR CODES

BL = BLACK	BL/W = BLACK / WHITE STRIPE
BU = BLUE	BL/Y = BLACK / YELLOW STRIPE
G = GREEN	W/BU = WHITE / BLUE STRIPE
GR = GRAY	
R = RED	
W = WHITE	
Y = YELLOW	

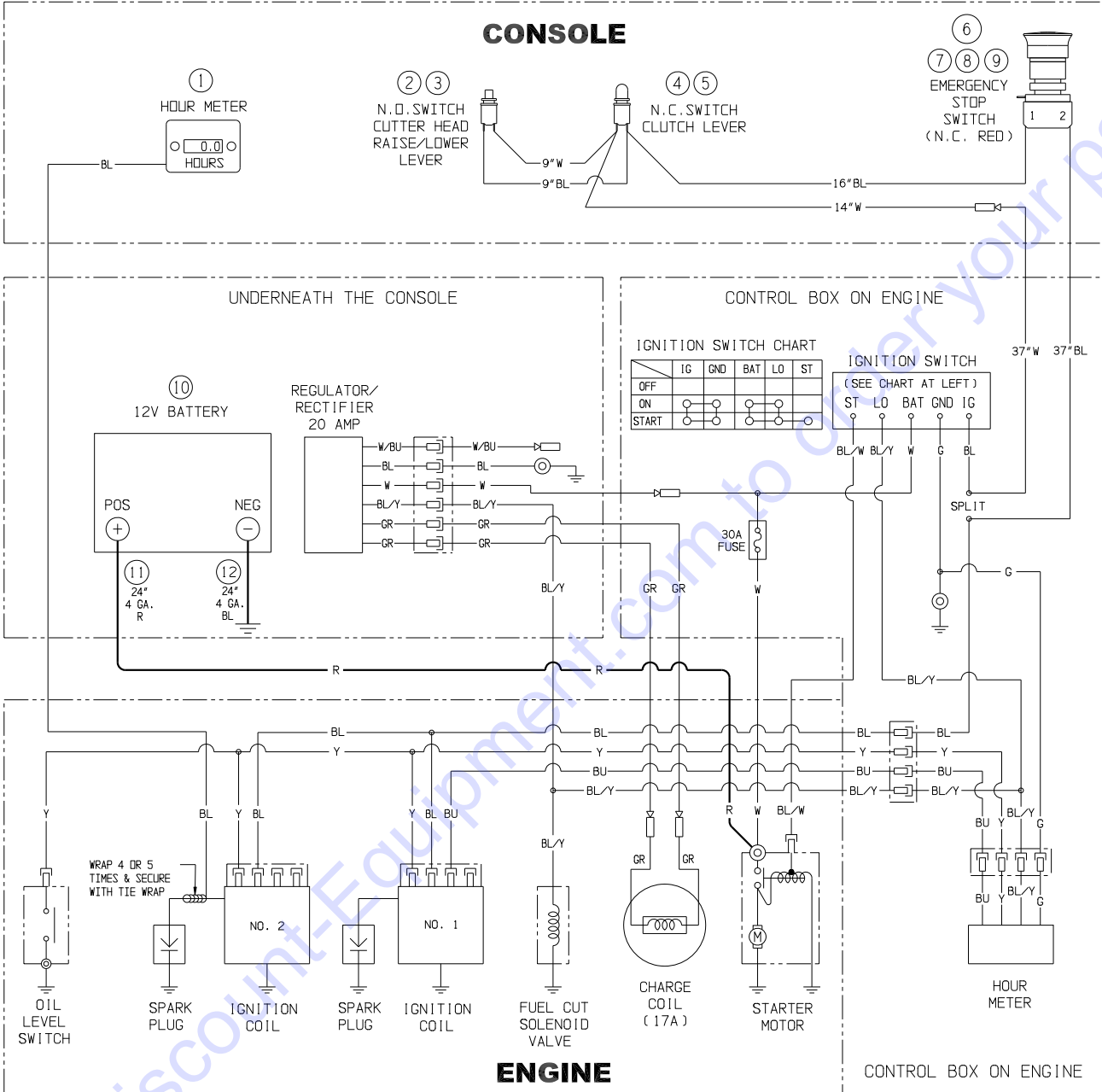

ITEM #	PART #	DESCRIPTION	QTY.	ITEM #	PART #	DESCRIPTION	QTY.
1	15138	HOUR METER, INDUCTIVE	1	7	15275	PUSHBUTTON, TURN TO RELEASE E-STOP	1
2	10992	SWITCH, PUSHBUTTON, N.O. MOMENTARY	1	8	15276	MOUNTING ADAPTER, PUSHBUTTON	1
3	10674	BOOT, TOGGLE SWITCH	1	9	15278	CONTACT ELEMENT, NC RED LM2TC01	1
4	10887	SWITCH, PUSHBUTTON, N.C. MOMENTARY	1	10	84011	BATTERY 12 VOLT/300 CCA	1
5	10997	BOOT, RED RUBBER, STOP SWITCH	1	11	50117R	CABLE, EYE-EYE 4GA. X 24" (RED)	1
6	15275-R	SWITCH, E-STOP W/ RED N.C. CONTACT (INCLUDES ITEMS 7, 8, & 9)	1	12	50117B	CABLE, EYE-EYE 4GA. X 24" (BLACK)	1

WIRING DIAGRAM FOR HONDA GX390

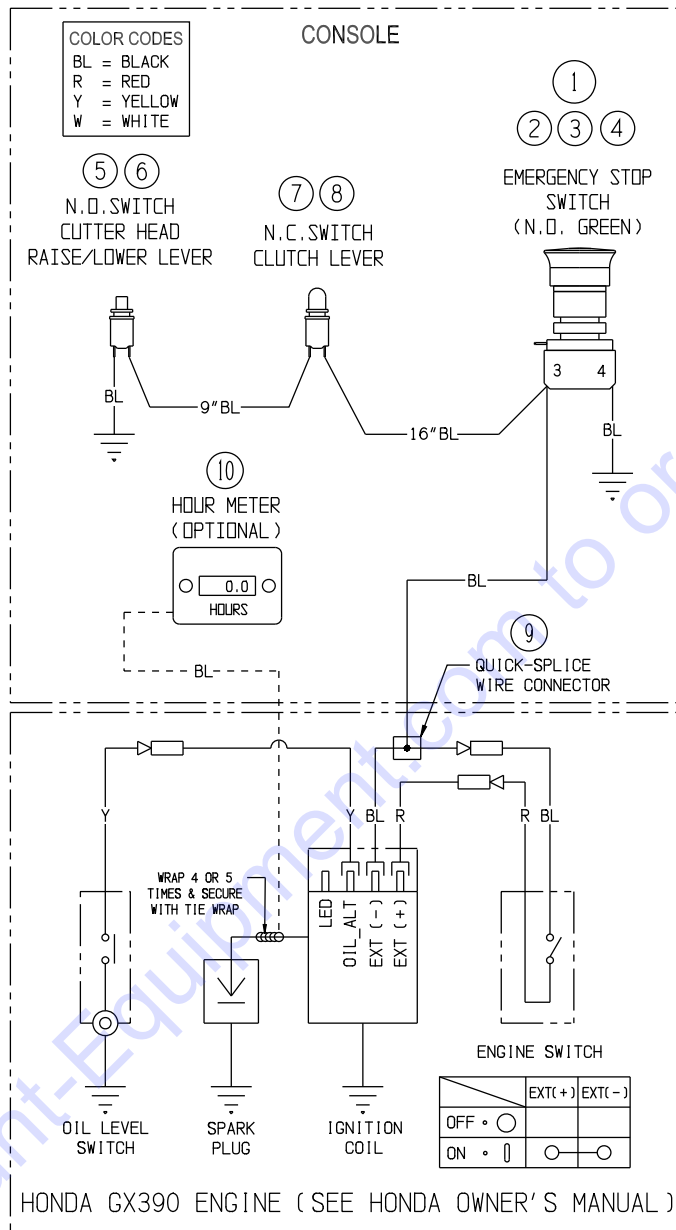

ITEM #	PART #	DESCRIPTION	QTY.	ITEM #	PART #	DESCRIPTION	QTY.
1	15275-G	SWITCH, E-STOP W/ GREEN N.O. CONTACT (INCLUDES ITEMS 2, 3, & 4)	1	6	10674	BOOT, TOGGLE SWITCH	1
2	15275	PUSHBUTTON, TURN TO RELEASE E-STOP	1	7	10887	SWITCH, PUSHBUTTON, N.C. MOMENTARY	1
3	15276	MOUNTING ADAPTER, PUSHBUTTON	1	8	10997	BOOT, RED RUBBER, STOP SWITCH	1
4	15277	CONTACT ELEMENT, NO GREEN LM2TC10	1	9	10970	CONN., WIRE QUICK-SPLICE 18-14 GA.	1
5	10992	SWITCH, PUSHBUTTON, N.O. MOMENTARY	1	10	15138	HOUR METER, INDUCTIVE (OPTIONAL)	1

STARTER CORD ARRANGEMENT

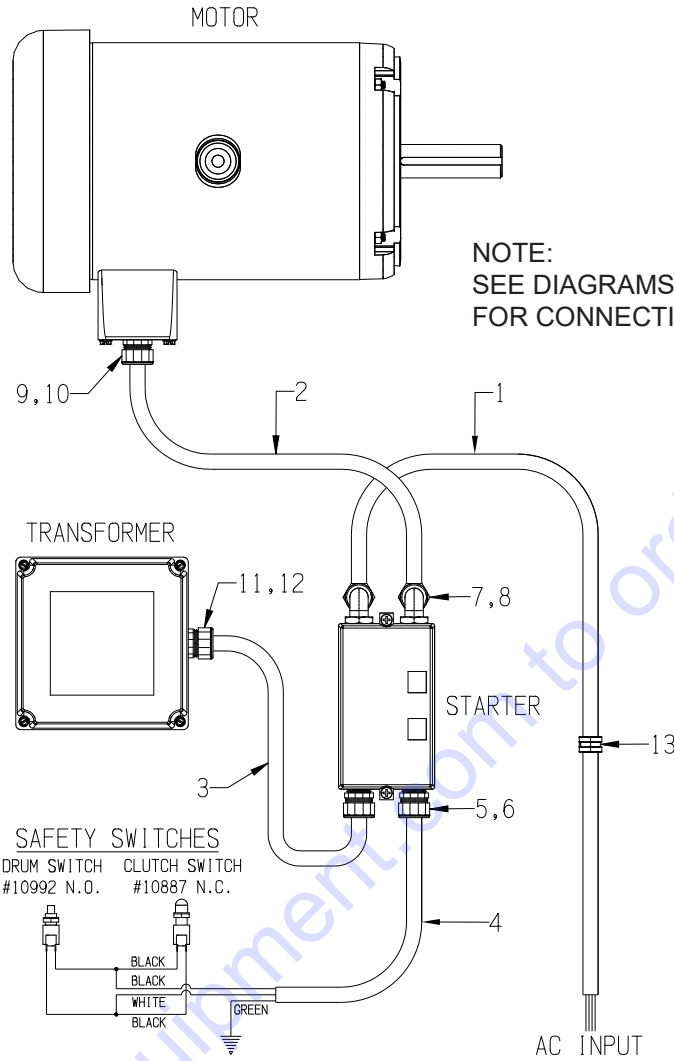

ITEM #	PART #	DESCRIPTION	QTY.
1	64413	WIRE HARNESS 10/4 X 50"LOA	1
2	64412	WIRE HARNESS 10/4 X 50"LOA	1
3	64415	WIRE HARNESS 16/7 X 48"LOA USE: BLACK, WHITE, RED, BLUE, & GREEN CUT OFF: WHITE W/ BLACK STRIPE & ORANGE	1
4	64414	WIRE HARNESS 16/3 X 40"LOA	1
5	40066	STRAIN RELIEF 1/2NPT X .350-.450"	1
6	10790	CONDUIT LOCK NUT 1/2 NP	1
7	10984	STRAIN RELIEF 90D X 3/4NPT .625-.75	2
8	10740	CONDUIT LOCK NUT 3/4 NP	2
9	16172	STRAIN RELIEF 1"NPT X .625-.750"	1
10	10770	CONDUIT LOCK NUT 1" NP	1
11	28032	STRAIN RELIEF 1/2NPT X .450-.560"	2
12	10790	CONDUIT LOCK NUT 1/2 NP	2
13	11565	CLAMP, LOOM, 5/8" (SAE SIZE 10)	1

**CONNECTION DIAGRAM FOR MOTOR
BALDOR EM3711T**

CD0005

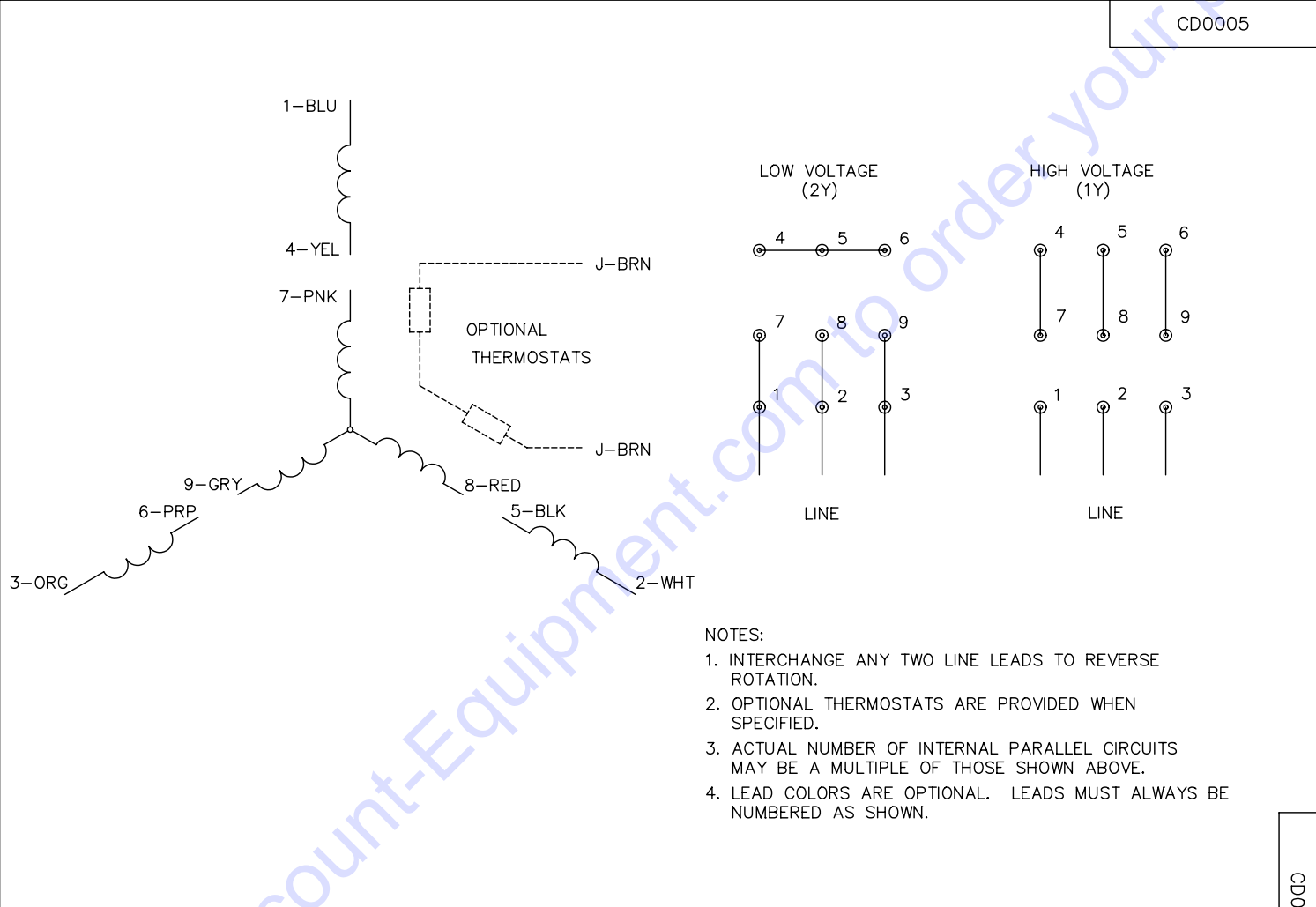

- NOTES:
1. INTERCHANGE ANY TWO LINE LEADS TO REVERSE ROTATION.
 2. OPTIONAL THERMOSTATS ARE PROVIDED WHEN SPECIFIED.
 3. ACTUAL NUMBER OF INTERNAL PARALLEL CIRCUITS MAY BE A MULTIPLE OF THOSE SHOWN ABOVE.
 4. LEAD COLORS ARE OPTIONAL. LEADS MUST ALWAYS BE NUMBERED AS SHOWN.

REV. DESC: REVISE TO SHOW OPTIONAL COLORS			
REV. LTR: E	BY: JLP	REVISED: 01/19/99 10:15	TDR: 0171435
S00000		FILE: AAA00005140	MDL: -
		MTL: -	

BALDOR ELECTRIC Co.

3PH, DV, 9 LEADS

CD0005

PARTS FINDER

**Search Website
by Part Number**



**Search Manual
Library For Parts
Manual & Lookup Part
Numbers – Purchase
or Request Quote**

Search Manuals

Enter your information to help us find the right parts manual for your machine.

* Brand:

* Model:

* Serial:

* Part Number:

SEARCH

**Can't Find Part or
Manual? Request Help
by Manufacturer,
Model & Description**

Parts Order Form

Please fill in the following information to help us find the right part for your machine.

Manufacturer:	<input type="text"/>
Model:	<input type="text"/>
Description:	<input type="text"/>
Part Number:	<input type="text"/>
Quantity:	<input type="text"/>
Notes:	<input type="text"/>

Submit

Discount-Equipment.com is your online resource for quality parts & equipment.

Florida: **561-964-4949** Outside Florida TOLL FREE: **877-690-3101**

Need parts?

Click on this link: <http://www.discount-equipment.com/category/5443-parts/> and choose one of the options to help get the right parts and equipment you are looking for. Please have the machine model and serial number available in order to help us get you the correct parts. If you don't find the part on the website or on one of the online manuals, please fill out the request form and one of our experienced staff members will get back to you with a quote for the right part that your machine needs.

We sell worldwide for the brands: Genie, Terex, JLG, MultiQuip, Mikasa, Essick, Whiteman, Mayco, Toro Stone, Diamond Products, Generac Magnum, Airman, Haulotte, Barreto, Power Blanket, Nifty Lift, Atlas Copco, Chicago Pneumatic, Allmand, Miller Curber, Skyjack, Lull, Skytrak, Tsurumi, Husquvarna Target, Stow, Wacker, Sakai, Mi-T-M, Sullair, Basic, Dynapac, MBW, Weber, Bartell, Bennar Newman, Haulotte, Ditch Runner, Menegotti, Morrison, Contec, Buddy, Crown, Edco, Wyco, Bomag, Laymor, EZ Trench, Bil-Jax, F.S. Curtis, Gehl Pavers, Heli, Honda, ICS/PowerGrit, IHI, Partner, Imer, Clipper, MMD, Koshin, Rice, CH&E, General Equipment, Amida, Coleman, NAC, Gradall, Square Shooter, Kent, Stanley, Tamco, Toku, Hatz, Kohler, Robin, Wisconsin, Northrock, Oztec, Toker TK, Rol-Air, APT, Wylie, Ingersoll Rand / Doosan, Innovatech, Con X, Ammann, Mecalac, Makinex, Smith Surface Prep, Small Line, Wanco, Yanmar