



REVISED STARTING
SERIAL # 19010484

PARTS LIST MANUAL



MODEL CPM8



GASOLINE MODEL



ELECTRIC MODEL

8" WALK BEHIND CRETE-PLANERS®

SKU #	MODEL #	POWER OPTION
79300	CPM8-9H	HONDA GASOLINE ENGINE MODEL GX270
79500	CPM8-5B/230/1	BALDOR ELECTRIC MOTOR 5HP 60Hz 1PH 230V
79400-230	CPM8-5B/230/3	BALDOR ELECTRIC MOTOR 5HP 60Hz 3PH 230V
79400-460	CPM8-5B/460/3	BALDOR ELECTRIC MOTOR 5HP 60Hz 3PH 460V
79400-50/220	CPM8-5B/50/220/3	BALDOR ELECTRIC MOTOR 5HP 50Hz 3PH 220V
79400-50/380	CPM8-5B/50/380/3	BALDOR ELECTRIC MOTOR 5HP 50Hz 3PH 380V
79400-50/440	CPM8-5B/50/440/3	BALDOR ELECTRIC MOTOR 5HP 50Hz 3PH 440V

**READ AND UNDERSTAND THE OPERATOR'S SAFETY MANUAL THOROUGHLY
BEFORE ATTEMPTING TO OPERATE THIS EQUIPMENT.**

Death or serious injury could occur if this machine is used improperly.

Machine specific Operator's Instruction Manuals are offered at <https://discount-equipment.com>

READ AND UNDERSTAND THE ENGINE MANUFACTURERS INSTRUCTIONS AND OPERATORS MANUAL BEFORE OPERATION.



PARTS FINDER

**Search Website
by Part Number**



**Search Manual
Library For Parts
Manual & Lookup Part
Numbers – Purchase
or Request Quote**

Search Manuals

Enter your information to help us find the right parts manual for your machine.

* Brand:

* Model:

* Serial:

* Part Number:

SEARCH

**Can't Find Part or
Manual? Request Help
by Manufacturer,
Model & Description**

Parts Order Form

Please fill in the following information to help us find the right part for your machine.

Manufacturer:	<input type="text"/>
Model:	<input type="text"/>
Description:	<input type="text"/>
Part Number:	<input type="text"/>
Quantity:	<input type="text"/>
Notes:	<input type="text"/>

Submit

Discount-Equipment.com is your online resource for quality parts & equipment.

Florida: **561-964-4949** Outside Florida TOLL FREE: **877-690-3101**

Need parts?

Click on this link: <http://www.discount-equipment.com/category/5443-parts/> and choose one of the options to help get the right parts and equipment you are looking for. Please have the machine model and serial number available in order to help us get you the correct parts. If you don't find the part on the website or on one of the online manuals, please fill out the request form and one of our experienced staff members will get back to you with a quote for the right part that your machine needs.

We sell worldwide for the brands: Genie, Terex, JLG, MultiQuip, Mikasa, Essick, Whiteman, Mayco, Toro Stone, Diamond Products, Generac Magnum, Airman, Haulotte, Barreto, Power Blanket, Nifty Lift, Atlas Copco, Chicago Pneumatic, Allmand, Miller Curber, Skyjack, Lull, Skytrak, Tsurumi, Husquvarna Target, Stow, Wacker, Sakai, Mi-T-M, Sullair, Basic, Dynapac, MBW, Weber, Bartell, Bennar Newman, Haulotte, Ditch Runner, Menegotti, Morrison, Contec, Buddy, Crown, Edco, Wyco, Bomag, Laymor, EZ Trench, Bil-Jax, F.S. Curtis, Gehl Pavers, Heli, Honda, ICS/PowerGrit, IHI, Partner, Imer, Clipper, MMD, Koshin, Rice, CH&E, General Equipment, Amida, Coleman, NAC, Gradall, Square Shooter, Kent, Stanley, Tamco, Toku, Hatz, Kohler, Robin, Wisconsin, Northrock, Oztec, Toker TK, Rol-Air, APT, Wylie, Ingersoll Rand / Doosan, Innovatech, Con X, Ammann, Mecalac, Makinex, Smith Surface Prep, Small Line, Wanco, Yanmar



SAFETY INFORMATION



SAFETY MESSAGES

• Safety Instructions are preceded by a graphic alert symbol of DANGER, WARNING, or CAUTION.

DANGER

Indicates an imminent hazard which, if not avoided, will result in death or serious injury.

WARNING

Indicates an imminent hazard which, if not avoided, can result in death or serious injury.

CAUTION

Indicates hazards which, if not avoided, could result in serious injury and or damage to the equipment.

GASOLINE / PROPANE POWERED EQUIPMENT

WARNING

• Engine exhaust from this product contains chemicals known to the State of California to cause cancer, birth defects or other reproductive harm.

WARNING

• Tilting a gasoline powered machine fitted with an EPA approved vented charcoal filter gas cap, beyond 20° can cause fuel leakage. If a leak occurs, do not start or run the engine until the leak is fixed. Eliminate all other ignition sources in the immediate area (no smoking, flares, sparks or flames). Use approved gasoline absorbing material to contain the fuel leakage. Then use clean, non-sparking tools to collect absorbed materials then dispose of these contaminants properly.



• Gasoline is extremely flammable and poisonous. It should only be dispensed in well ventilated areas, and with a cool engine.

• Small gasoline engines produce high concentrations of carbon monoxide (CO) example: a 5 HP 4 cycle engine operation in an enclosed 100,000 cu. ft. area with only one change of air per hour is capable of providing deadly concentrations of CO in less than fifteen minutes. Five changes of air in the same area will produce noxious fumes in less than 30 minutes. Gasoline powered equipment should not be used in enclosed or partially enclosed areas. Symptoms of CO poisoning include, head-ache, nausea, weakness, dizziness, visual problems and loss of consciousness. If symptoms occur - get into fresh air and seek medical attention immediately.

- Never refuel a hot engine or an engine while it is running.
- Engines are shipped from factory without fuel/oil.



• Propane is extremely flammable and is heavier than air and tends to settle in low areas where a spark or flame could ignite gas. DO NOT start or operate this propane engine in a poorly ventilated area where leaking propane gas could accumulate and endanger safety of persons in area. If headache develops, shut off machine. Have it checked for carbon monoxide emissions by a qualified technician before using it again. To ensure personal safety, installation and repair of propane fuel supply systems must be performed only by qualified technicians. Carbon monoxide emissions from this machine are greatly increased due to a dirty combustion air cleaner.

ELECTRICAL POWERED EQUIPMENT



Extreme care must be taken when operating electric models with water present: Ensure power cord is properly grounded, is attached to a Ground-Fault-Interrupter (GFI) outlet, and is undamaged.

- Check all electrical cables - be sure connections are tight and cable is continuous and in good condition. Be sure cable is correctly rated for both the operating current and voltage of this equipment.
- Improper connection of the equipment grounding conductor can result in a risk of electric shock. Check with qualified electrician or service person if there is any doubt as to whether the outlet is properly grounded. Adhere to all local codes and ordinances.
- NOTE: In the event of a malfunction or breakdown, grounding provides a path of least resistance for the electric current to dissipate. The motor is equipped with a grounded plug and must be connected to an outlet that is properly installed and properly grounded. DO NOT modify the plug provided on the motor. If the plug does not fit the outlet have a qualified electrician install the proper receptacle.

ELECTRICAL POWERED EQUIPMENT CONTINUED

- Do not disconnect power by pulling cord. To disconnect, grasp the plug, not the cord.
- Unplug power cord at the machine when not in use and before servicing.
- Switch motor OFF before disconnecting power.
- Never use frayed, damaged, taped or under rated extension cords. Electrical shock could result in death or serious injury to the operator and damage to the equipment.
- Assure you are using the proper extension cord length.

GENERAL INSTRUCTIONS

- Equipment should only be operated by trained personnel in good physical condition and mental health (not fatigued). The operator and maintenance personnel must be physically able to handle the bulk weight and power of this equipment.
- This is a one person tool. Maintain a safe operating distance to other personnel. It is the operators' responsibility to keep other people (workers, pedestrians, bystanders, etc.) away during operation. Block off the work area in all directions with roping, safety netting, etc. Failure to do so may result in others being injured by flying debris or exposing them to harmful dust and noise.
- This equipment is intended for commercial use only.
- For the operator's safety and the safety of others, always keep all guards in place during operation.
- Never let equipment run unattended.



- Personal Protection Equipment and proper safety attire must be worn when operating this machinery. The operator must wear approved safety equipment appropriate for the job such as hard hat and safety shoes when conditions require. Hearing protection **MUST** be used when operational noise levels of this equipment may exceed 85db. Eye protection **MUST** be worn at all times.



Keep body parts, loose clothing and accessories away from moving parts. Failure to do so could result in dismemberment or death.

- Do not modify the machine.
- Stop motor/engine when adjusting or servicing this equipment. Maintain a safe operating distance from flammable materials. Sparks from the cutting-action of this machine can ignite flammable materials or vapors.



DUST WARNING

WARNING

Some dust created by power sanding, sawing, grinding, drilling, and other construction activities contains chemicals known to cause cancer, birth defects, or other reproductive harm. Materials being removed can be toxic or hazardous. A breathing respirator is required to help protect the operator. Some examples of these chemicals are:

- Lead from lead-based paints.
- Crystalline silica from bricks, concrete and other masonry products. Your risk of exposure to these chemicals varies depending on how often you do this type of work. To reduce your risk: work in a well ventilated area, use a dust control system, such as an industrial-style vacuum, and wear approved personal safety equipment, such as a dust/particle respirator designed to filter out microscopic particles.
- See more on the importance of dust prevention and silica warnings at: osha.gov/silica

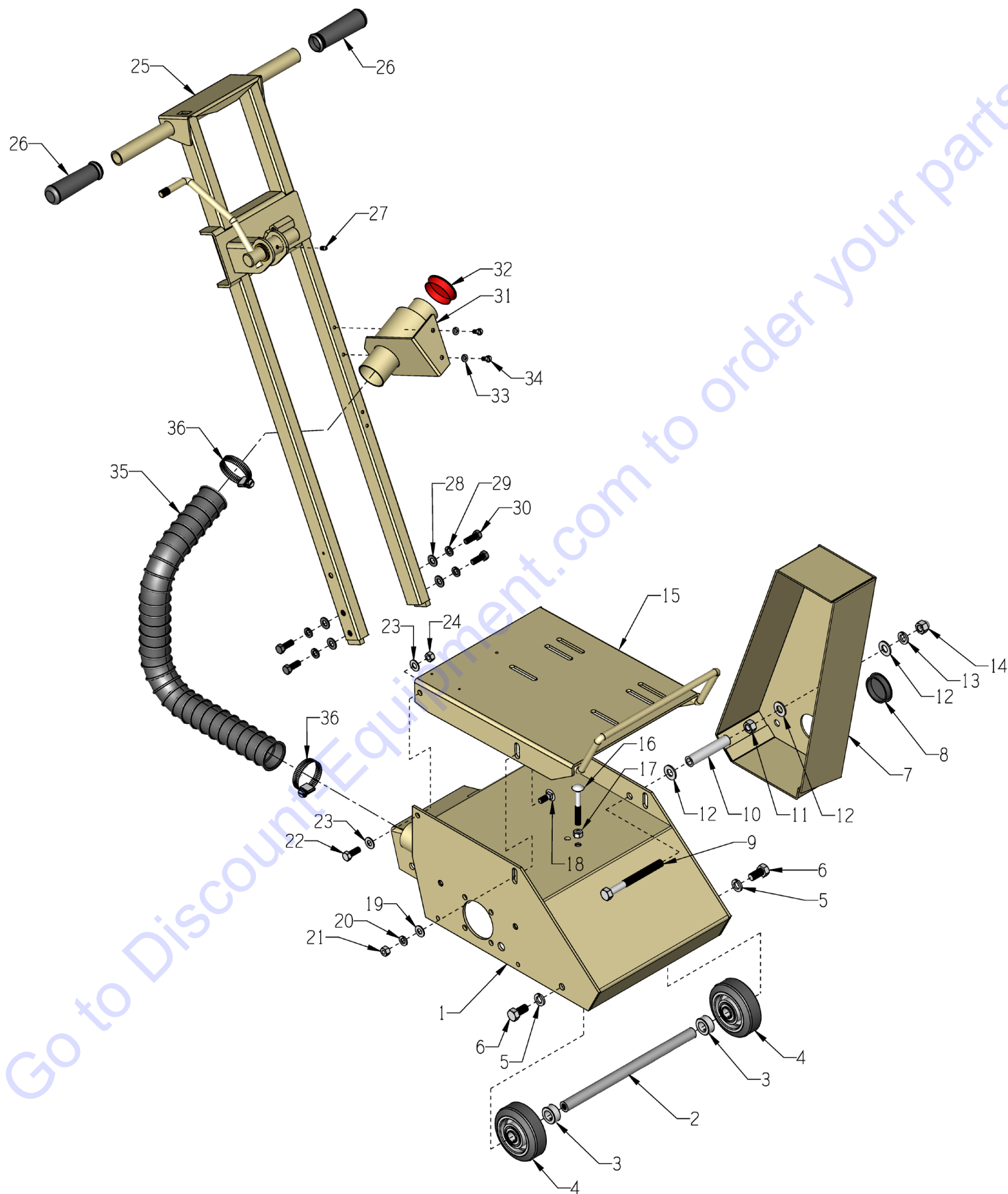
PARTS LIST MANUAL

MODEL CPM8 8" WALK BEHIND CRETE-PLANER®

TABLE OF CONTENTS

Section	Page Number
Safety Messages and General Instructions	2
How To Order Replacement Parts	3
Illustration 1: Main Grouping	4, 5
Illustration 2: Rear Fork & Control Linkage Grouping	6, 7
Illustration 3: Optional Water System Kit	8
Illustration 4: Rubber Seal Grouping	9
Illustration 5: Drum, Shaft & Bearing Grouping	10
Illustration 6: Cutter Drum Assembly (Standard - 8" Width)	11
Illustration 7: Optional Edger Assembly	12
Illustration 8: Optional Edger Cutter Drum Assembly (4" Width)	13
Illustration 9: Optional Diamond Grooving Head Assembly (7" Width)	14
Diamond Grooving Head Set-Ups	15, 16, 17
Illustration 10: Optional Lifting Bail Assembly	19
Illustration 11: Engine Grouping	20, 21
Illustration 12: Single Phase Motor Grouping	22, 23
Illustration 13: Three Phase Motor Grouping	24, 25
Wiring Diagram for Rotary Cam Switch	26
Wiring Diagram for 60Hz 1-Phase Motor	27
Wiring Diagram for Starter & Remote Switch	28
Wiring Diagram for 60Hz 3-Phase Motor	29
Wiring Diagram for 50Hz 3-Phase Motor	30
Wiring Diagram for Honda Engine	31
Decal Sheet	32
Decals Continued	33
Notes	34
Limited Equipment Warranty of Sale	35
STOP - Before Using This Product	36

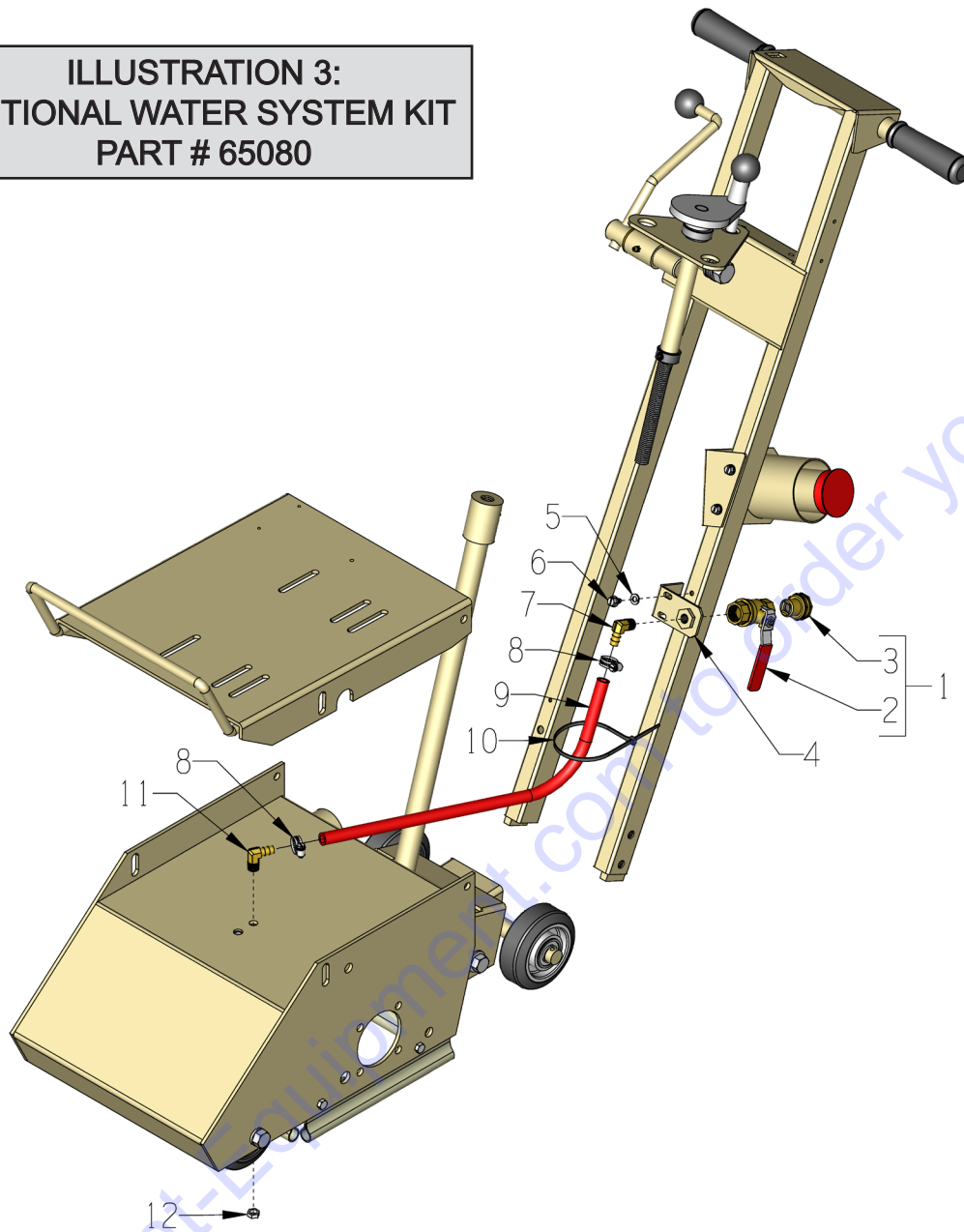
ILLUSTRATION 1: MAIN GROUPING



PARTS LISTING - ILLUSTRATION 1: MAIN GROUPING			
ITEM #	PART #	DESCRIPTION	QTY.
1	65001	MAIN FRAME, CPM-8	1
2	65014	AXLE SHAFT 3/4"DIA. X 12-3/16"L	1
3	10428	COLLAR, LOCKING 3/4"ID	2
4	52001	WHEEL 4 X 1-1/2 X 3/4"BRG.	2
5	10045	WASHER, LOCK 1/2 ZINC	2
6	10304	SCREW, CAP 1/2-20 X 1	2
7	65003	COVER, BELT, CPM-8	1
8	65022	PLUG, HOLE 2"	1
9	65125	SCREW, CAP 1/2-13 X 5-1/4	2
10	65016	SPACER TUBE 1/2"ID X 3-3/4"L, CPM-8	2
11	10417	NUT, HEX 1/2-13 ZINC	2
12	10312	WASHER, FLAT 1/2 SAE ZINC	6
13	10045	WASHER, LOCK 1/2 ZINC	2
14	10865	NUT, ACORN 1/2-13	2
15	65002	MOUNT, ENGINE/MOTOR, CPM-8	1
16	10909	BOLT, CARRIAGE 3/8-16 X 3 ZINC	1
17	10404	NUT, HEX 3/8-16 ZINC	1
18	10802	BOLT, CARRIAGE 3/8-16 X 1 ZINC	2
19	10025	WASHER, FLAT 3/8 SAE ZINC	2
20	10811	WASHER, LOCK 3/8 ZINC	2
21	10404	NUT, HEX 3/8-16 ZINC	2
22	10021	SCREW, CAP 3/8-24 X 1	2
23	10025	WASHER, FLAT 3/8 SAE ZINC	4
24	10058	NUT, HEX LOCK 3/8-24 W/ NYLON PATCH	2
25	65009	HANDLE BAR, CPM-8	1
26	10608	GRIP, HAND 1" MODEL AT	2
27	10808	FITTING, GREASE 1/4-28 STRAIGHT (SEE ILLUS. 2)	1
28	10025	WASHER, FLAT 3/8 SAE ZINC	4
29	10811	WASHER, LOCK 3/8 ZINC	4
30	10055	SCREW, CAP 3/8-16 X 1	4
31	86347	BRACKET, MULTI-VAC PORT 2-3"	1
32	65021	CAP/PLUG 2" RED PLASTIC, FLANGED	1
33	10038	WASHER, LOCK 1/4 ZINC	2
34	10846	SCREW, CAP STSHW 1/4-20 X 1/2	2
35	65098	HOSE, FLEX 2"ID X 22"L	1
36	10766	CLAMP, HOSE, SAE #32, ADJ. TO 2-1/2	2

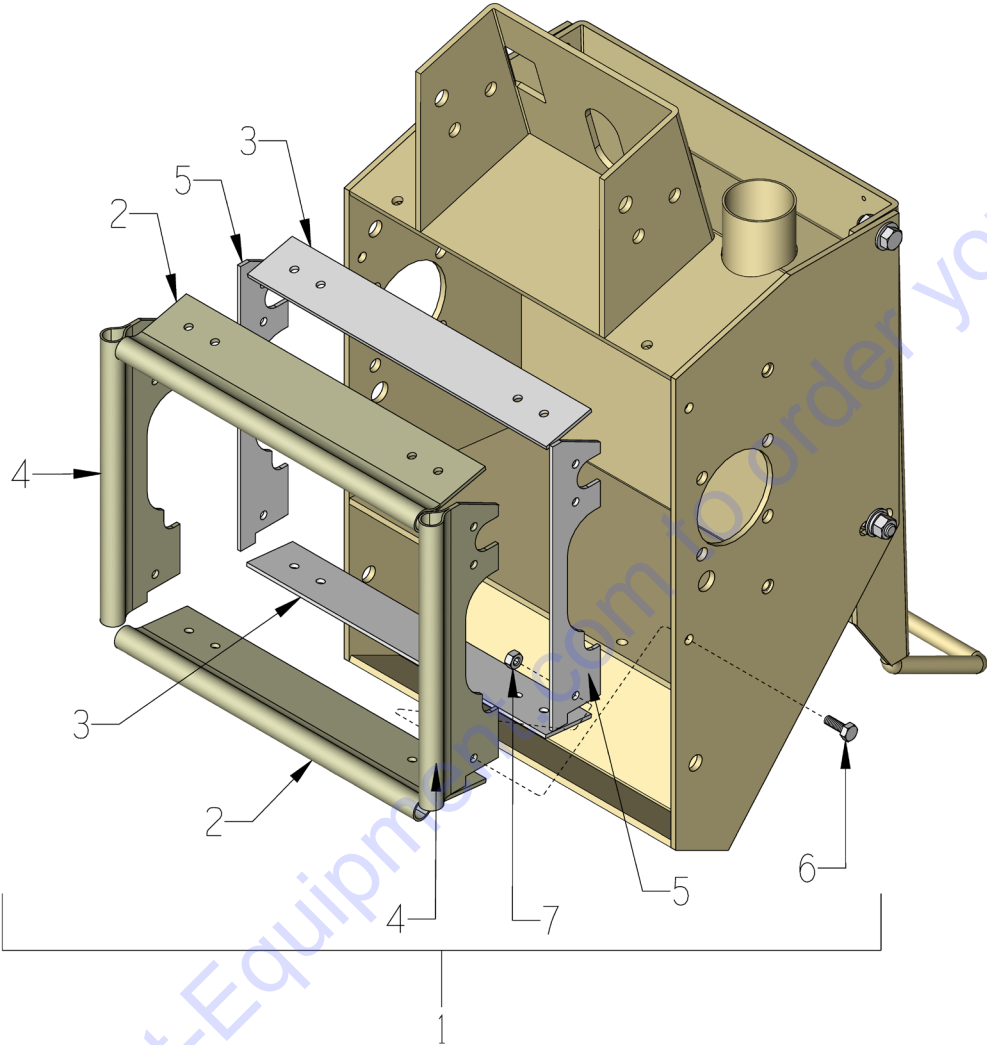
PARTS LISTING - ILLUSTRATION 2: REAR FORK & CONTROL LINKAGE GROUPING			
ITEM #	PART #	DESCRIPTION	QTY.
1	14023	KNOB, BALL 1-3/8 W/ 1/2-13THD, BLK.	2
2	10411	SCREW, SKT. HD. CAP 1/2-13 X 4 ZINC	1
3	50550	SLEEVE, BRASS 1/2" TAPERED	1
4	65019	HANDWHEEL, SMALL W/ 5/8-8 X 13"ROD	1
5	85005	BEARING, THRUST BALL 5/8	1
6	10073	WASHER, FLAT 5/8 SAE ZINC	4
7	65007	LINKAGE SUPPORT, UPPER, CPM-4/8	1
8	10359	SCREW, CAP 5/8-11 X 3-1/4	1
9	79035	BUSHING, RUBBER 1-1/16 X 5/8 X 1/4	1
10	10127	SCREW, DRIVE 1/8 X 1/4"L	1
11	10808	FITTING, GREASE 1/4-28 STRAIGHT	2
12	10096	COLLAR, LOCKING 5/8"ID	1
13	65006	LINKAGE, LOWER, CPM-8	1
14	65004	FORK, CPM-8	1
15	65005	SPACER, REAR WHEEL, 2-1/8", CPL/M-8	2
16	52001	WHEEL 4 X 1-1/2 X 3/4"BRG. ALUM/RUB	2
17	10306	PIN, COTTER 3/16 X 1-1/2	2
18	81001	SCREW, CAP 1/2-13 X 4	1
19	10407	NUT, HEX LOCK 1/2-13 ZINC	2
20	65015	SCREW, CAP 1/2-13 X 8 ZINC	1
21	10312	WASHER, FLAT 1/2 SAE ZINC	2

**ILLUSTRATION 3:
OPTIONAL WATER SYSTEM KIT
PART # 65080**



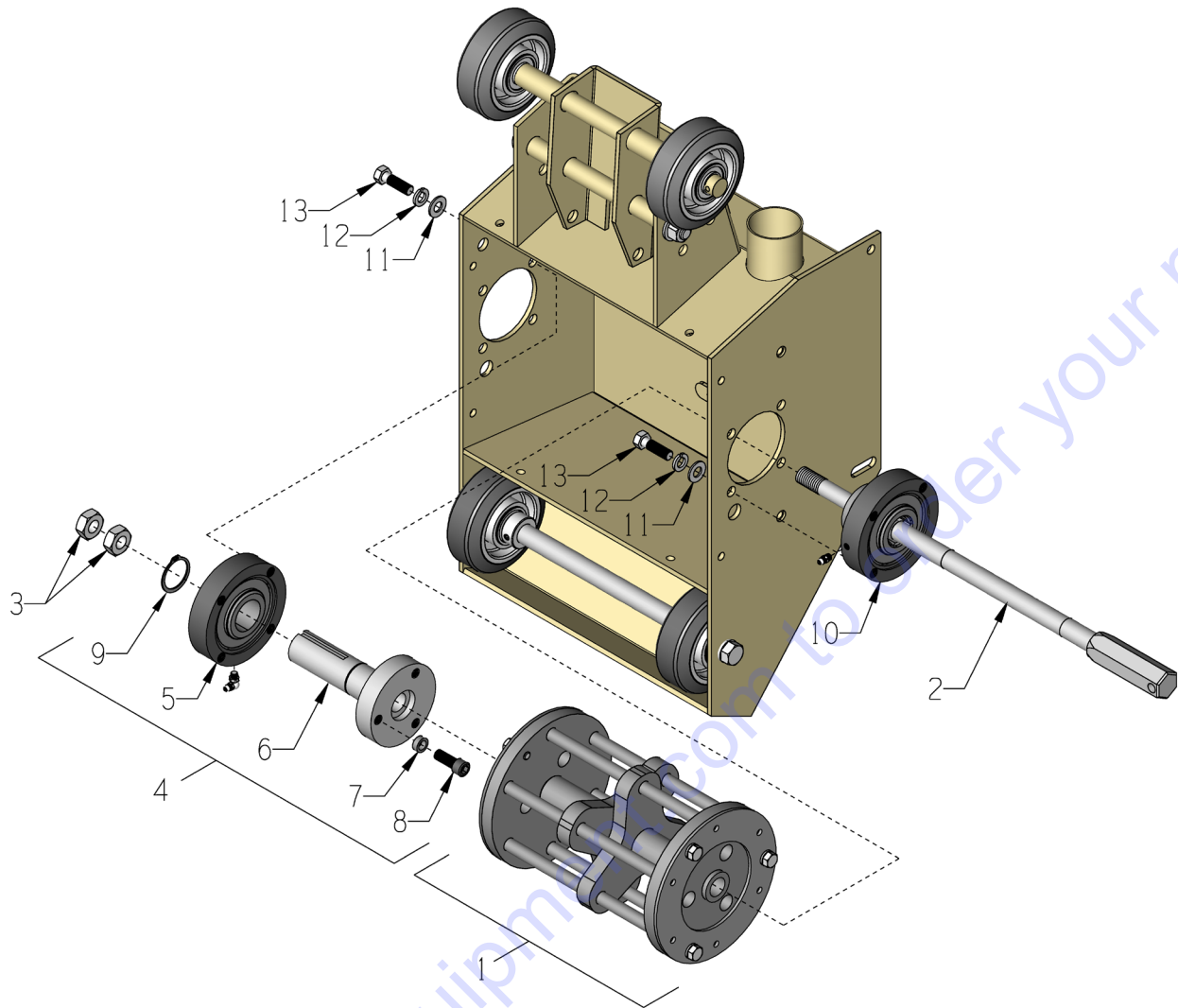
ITEM #	PART #	DESCRIPTION	QTY.
1	10711A	VALVE & HOSE CONNECTOR ASSY. (INCLUDES ITEMS 2 & 3)	1
2	10711	VALVE, BALL 1/2 FPT	1
3	80021	CONN., SWIVEL FEM. 3/4HOSE X 1/2MPT	1
4	56022	BRACKET, WATER VALVE	1
5	10038	WASHER, LOCK 1/4 ZINC	2
6	10846	SCREW, CAP STSHW 1/4-20 X 1/2	2
7	10799	BARB ELBOW 90, 3/8HOSE X 1/4MPT	1
8	10714	CLAMP, HOSE, SAE #4, ADJ. TO 5/8"	2
9	65089	HOSE, WATER 3/8"ID X 20"L	1
10	10982	TIE, CABLE, BLACK NYLON 11-1/4"	1
11	11562	BARB ELBOW 90, 3/8HOSE X 1/8MPT	1
12	10864	NUT, HEX PANEL 1/8-27 NPSM ZINC	1

ILLUSTRATION 4: RUBBER SEAL GROUPING



ITEM #	PART #	DESCRIPTION	QTY.
1	65036-R	RUBBERS (SET OF 4), CPM-8 INCLUDES ITEMS 2 THRU 8)	1
2	65152	RUBBER DUST SKIRT, FRONT/REAR	2
3	65153	RUBBER DUST SKIRT RETAINER, FRONT/REAR	2
4	65151	RUBBER DUST SKIRT, SIDE	2
5	65154	RUBBER DUST SKIRT RETAINER, SIDES	2
6	10018	SCREW, CAP 1/4-20 X 3/4	8
7	10015	NUT, HEX LOCK 1/4-20 ZINC	8

ILLUSTRATION 5: DRUM, SHAFT & BEARING GROUPING

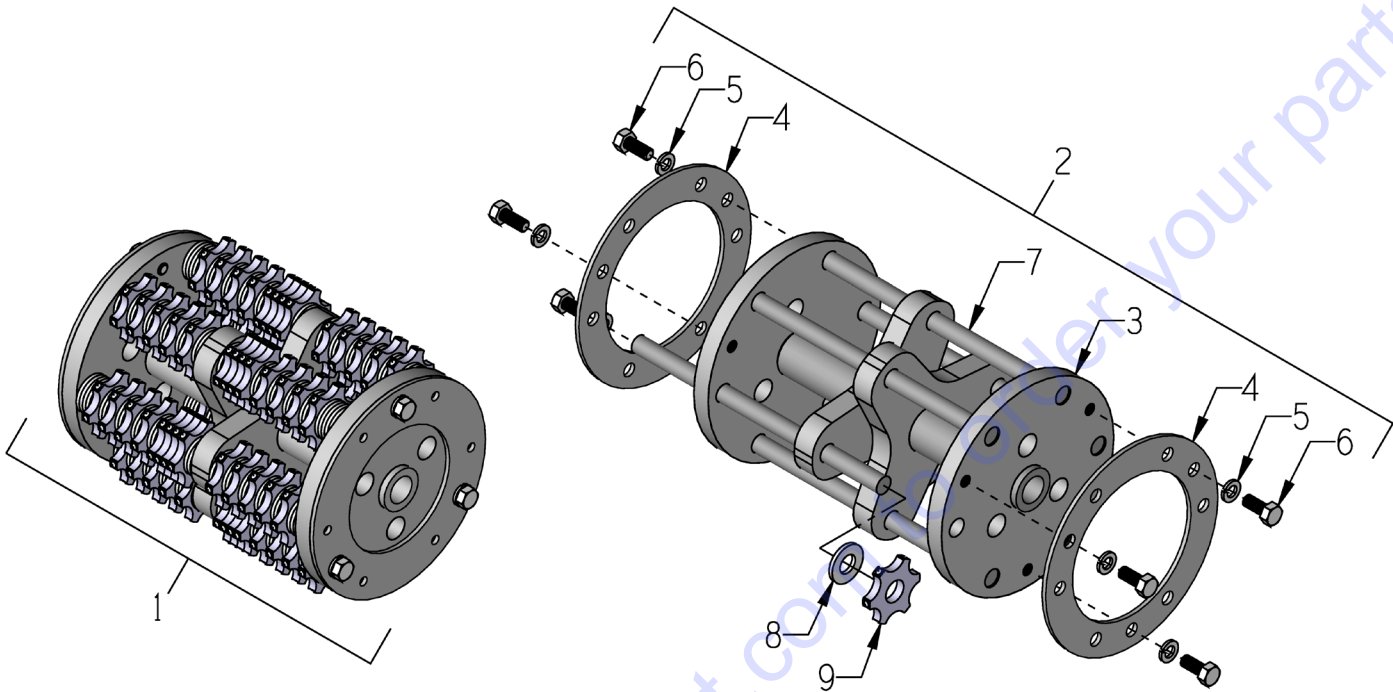


ITEM #	PART #	DESCRIPTION	QTY.
1	65050	DRUM ASSY. COMP. CPM-8 CUTTER (REFER TO ILLUS. 6 FOR BREAKDOWN)	1
2	65037	DRUM SHAFT 18-3/8"L, CPL/M-8	1
3	65039	NUT, HEX JAM 5/8-11 LEFT-HAND, ZINC	2
4	65038A	DRIVER W/ BEARING ASSY., CPL/M-8 (INCLUDES ITEMS 5 THRU 9)	1
5	65056	BEARING ASSY. COMPLETE, 1-1/4"DIA.	1
	10961	FITTING, GREASE 1/4-28 X 90° (INCLUDED)	1
6	65038	DRIVER, CPL-8 & CPM-8	1
7	10113	SPACER, STEEL 9/16OD X 3/8ID X 7/32	3
8	10878	SCREW, SKT. HD. CAP 3/8-24 X 1 ZINC	3
9	10873	RETAINING RING, EXT. 1-1/4"	1
10	65057	BEARING ASSY. COMPLETE, 1"HEX BORE	1
	10808	FITTING, GREASE 1/4-28 STR. (INCLUDED)	1
11	10025	WASHER, FLAT 3/8 SAE ZINC	8
12	10811	WASHER, LOCK 3/8 ZINC	8
13	10309	SCREW, CAP 3/8-24 X 1-1/4 ZINC	8

**ILLUSTRATION 6:
CUTTER DRUM ASSEMBLY**

E-CPM8-PL-0119

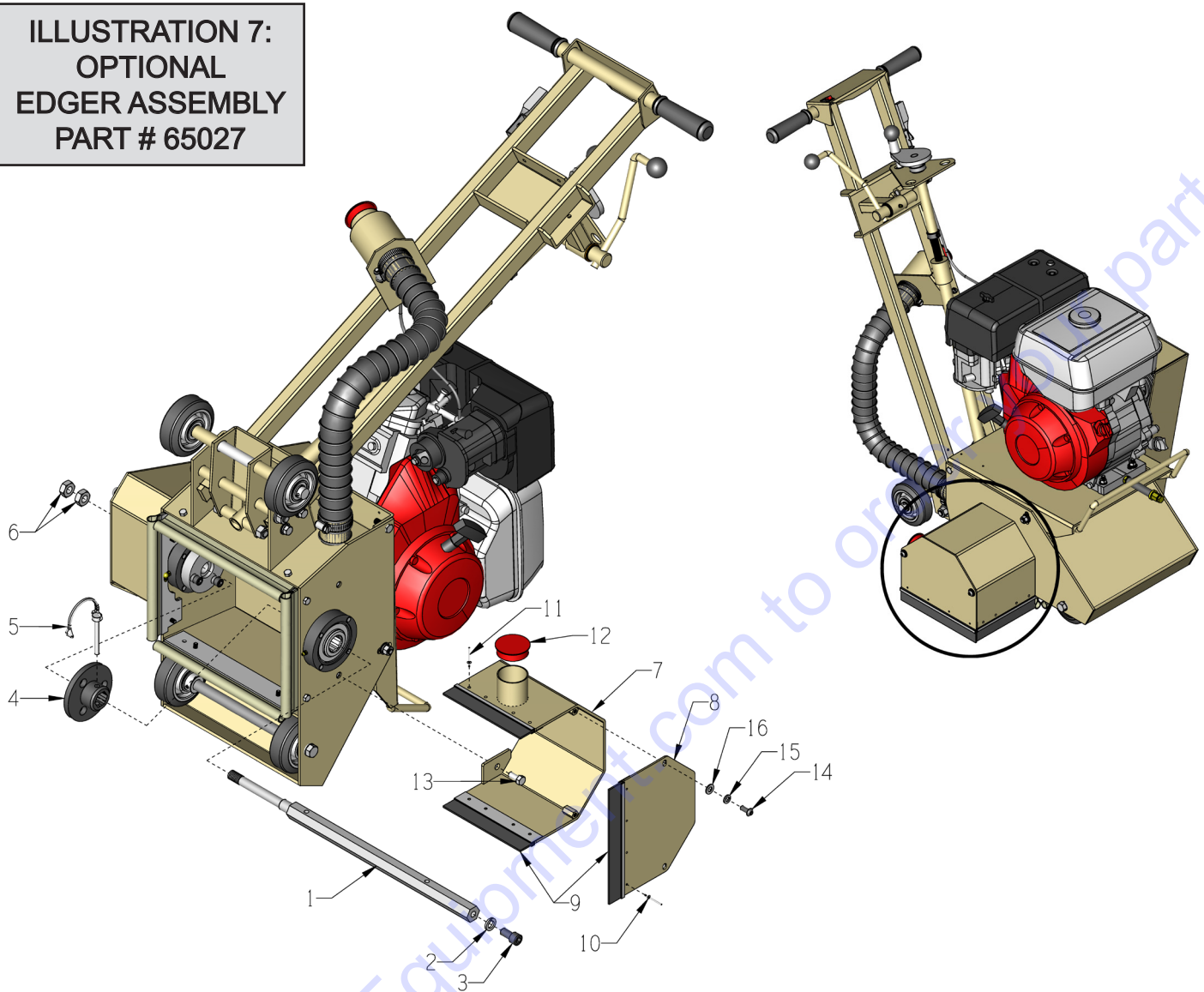
STANDARD - 8" WIDTH



ITEM #	PART #	DESCRIPTION	QTY.
1	65050C	DRUM ASSY LOADED W/ CUTTERS CPM8 LOADED WITH 78 CP206T CUTTERS & 210 CG227 SPACERS	1
2*	65050	DRUM ASSY. COMPLETE, CPM-8 CUTTER (INCLUDES ITEMS 2 THRU 6)	1
3	65051	DRUM ONLY, CUTTER, CPM-8	1
4	65054	RETAINING PLATE, CUTTER SHAFT	2
5	10801	WASHER, LOCK 5/16 ZINC	6
6	10053	SCREW, CAP 5/16-18 X 3/4	6
7	20150	CP407 SHAFT 1/2 X 8-9/16"L	6
8*	12230	CG227 SPACER 1/2"ID	SEE NOTE
9*		CUTTERS:	
	20156	CP206T 6-PT. CARBIDE 1-3/4"OD x 5/8"ID x 1/4"THK (SHOWN)	SEE NOTE
	20336	CP207T 7-PT. SOLID CARBIDE MILLING 1-1/2"OD x 1/2"ID x 1/2"THK	
	12206	JRS501P 18-PT. POINTED STEEL 2"OD x 1/2"ID x 3/16"THK	
	20206	CP305 12-PT. FLAT TIP STEEL 2"OD x 5/8"ID x 3/16"THK	

*NOTE:
CUTTER WHEELS AND SPACERS ARE NOT INCLUDED WITH THE DRUM ASSEMBLY.
THE NUMBER OF CUTTER WHEELS AND SPACERS VARY WITH TYPE OF SET-UP USED.
REFER TO ASSEMBLY PROCEDURES FOR SUGGESTED SET-UPS AND QUANTITIES.

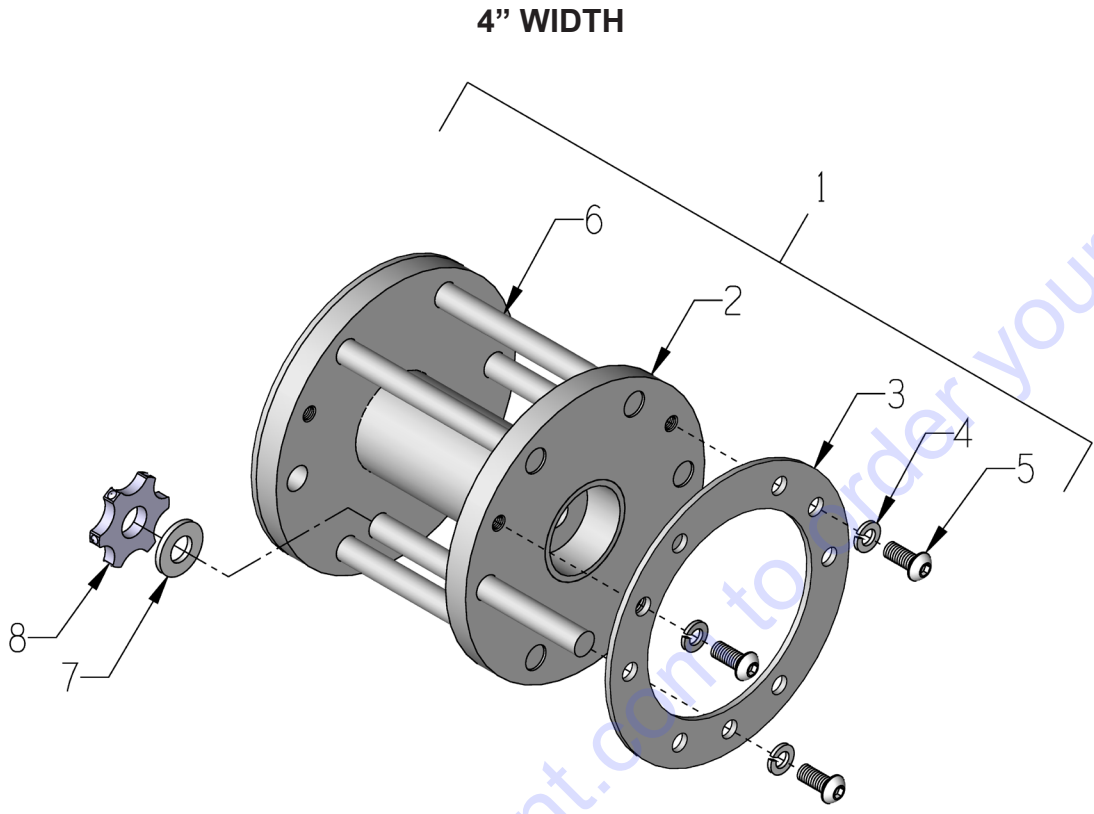
**ILLUSTRATION 7:
OPTIONAL
EDGER ASSEMBLY
PART # 65027**



ITEM #	PART #	DESCRIPTION	QTY.
1	65025	DRUM SHAFT, CPM-8 EDGER	1
2	10420	WASHER, LOCK 1/2 HEAVY-DUTY	1
3	10490	SCREW, SKT. HD. CAP 1/2-13 X 1	1
4	65026	FLANGE, DRIVER, CPM-8 EDGER	1
5	65028	PIN, WIRE LOCK 5/16" DIA. X 2.75" GRP	1
6	65039	NUT, JAM 5/8-11 LEFT-HAND THD. ZINC	2
7	65023A	COVER ONLY, DRUM, CPM-8 EDGER	1
8	65024A	COVER SIDE PANEL ONLY, CPM-8 EDGER	1
9	65029	BRUSHES (SET OF 3), CPM-8 EDGER	1-SET
10	10128	RIVET, BLIND 1/8 X .250L X .262HD	4
11	10134	RIVET, BLND 3/16X.450"L X.375HD DIA	8
12	65021	CAP/PLUG 2" RED PLASTIC, FLANGED	1
13	10055	SCREW, CAP 3/8-16 X 1	2
14	10627	SCREW, SKT. BUTTON HD. 5/16-18 X3/4	2
15	10801	WASHER, LOCK 5/16 ZINC	2
16	10213	WASHER, FLAT 5/16 SAE ZINC	2

**ILLUSTRATION 8:
OPTIONAL EDGER CUTTER DRUM ASSEMBLY**

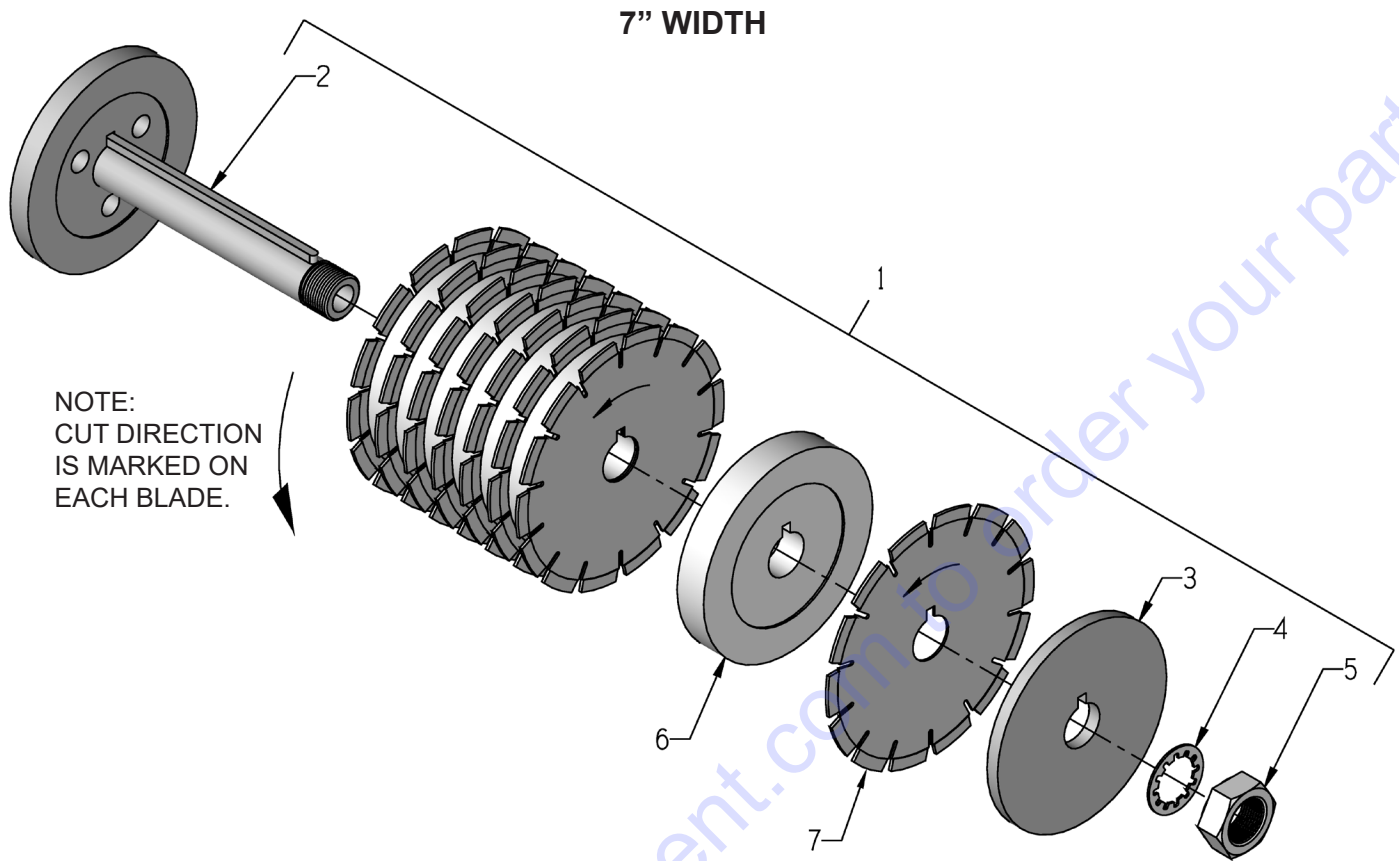
E-CPM8-PL-0119



ITEM #	PART #	DESCRIPTION	QTY.
1*	C66040	DRUM ASSY. COMPLETE, CPM-4 CUTTER (INCLUDES ITEMS 2 THRU 6)	1
2	C66041	DRUM ONLY, CUTTER, CPM-4	1
3	65054	RETAINING PLATE, CUTTER SHAFT	1
4	10801	WASHER, LOCK 5/16 ZINC	3
5	10627	SCREW, SKT. BUTTON HD. 5/16-18 X3/4	3
6	C66043	CP410 SHAFT 1/2 X 5-3/16"L, CPM-4	6
7*	12230	CG227 SPACER 1/2"ID	SEE NOTE
8*		CUTTERS:	SEE NOTE
	20156	CP206T 6-PT. CARBIDE 1-3/4"OD x 5/8"ID x 1/4"THK (SHOWN)	
	20336	CP207T 7-PT. SOLID CARBIDE MILLING 1-1/2"OD x 1/2"ID x 1/2"THK	
	12206	JRS501P 18-PT. POINTED STEEL 2"OD x 1/2"ID x 3/16"THK	
	20206	CP305 12-PT. FLAT TIP STEEL 2"OD x 5/8"ID x 3/16"THK	

***NOTE:**
CUTTER WHEELS AND SPACERS ARE NOT INCLUDED WITH THE DRUM ASSEMBLY.
THE NUMBER OF CUTTER WHEELS AND SPACERS VARY WITH TYPE OF SET-UP USED.
REFER TO ASSEMBLY PROCEDURES FOR SUGGESTED SET-UPS AND QUANTITIES.

**ILLUSTRATION 9:
OPTIONAL DIAMOND GROOVING HEAD ASSEMBLY**



ITEM #	PART #	DESCRIPTION	QTY.
1*	65077	HEAD ASSY., DIAMOND GROOVING, CPM-8 (INCLUDES ITEM 2 THRU 5)	1
2	65070	ARBOR, DIAMOND GROOVING HEAD, CPM-8	1
3	65071	ARBOR BLADE CAP 6", CPM-8	1
4	65075	WASHER, LOCK, INT. TOOTH 1-1/4"	1
5	65076	NUT, HEX JAM 1 1/4-12	1
6*	65072 65073 65078 65074	SPACERS: 6"OD X 1-1/4"ID X .063 (MINIMUM BLADE SPACING) 6"OD X 1-1/4"ID X .430 6"OD X 1-1/4"ID X .625 6"OD X 1-1/4"ID X .930 (SHOWN)	SEE NOTE
7*	39808 39837 39806	7"DIA. DIAMOND BLADES WITH 1.25" HOLE & KEYWAY: DIAM.BLADE DCC05S 7X.090X1.25 W/ KW (3/32"THK.) DIAM.BLADE DCC05S 7X.125X1.25 W/ KW (1/8"THK.) DIAM.BLADE DCC05S 7X.250X1.25 W/ KW (1/4"THK.)	SEE NOTE

*NOTE:
DIAMOND BLADES AND SPACERS ARE NOT INCLUDED WITH THE HEAD ASSEMBLY.
THESE QUANTITIES VARY WITH THE TYPE OF SET-UP USED.
REFER TO SET-UP DRAWINGS ON PAGES 15, 16 AND 17 FOR QUANTITIES.

PARTS FINDER

**Search Website
by Part Number**



**Search Manual
Library For Parts
Manual & Lookup Part
Numbers – Purchase
or Request Quote**

Search Manuals

Enter your information to help us find the right parts manual for your machine.

* Brand:

* Model:

* Serial:

* Part Number:

SEARCH

**Can't Find Part or
Manual? Request Help
by Manufacturer,
Model & Description**

Parts Order Form

Please fill in the following information to help us find the right part for your machine.

MANUFACTURER:

MODEL:

DESCRIPTION:

SEARCH

Discount-Equipment.com is your online resource for quality parts & equipment.

Florida: **561-964-4949** Outside Florida TOLL FREE: **877-690-3101**

Need parts?

Click on this link: <http://www.discount-equipment.com/category/5443-parts/> and choose one of the options to help get the right parts and equipment you are looking for. Please have the machine model and serial number available in order to help us get you the correct parts. If you don't find the part on the website or on one of the online manuals, please fill out the request form and one of our experienced staff members will get back to you with a quote for the right part that your machine needs.

We sell worldwide for the brands: Genie, Terex, JLG, MultiQuip, Mikasa, Essick, Whiteman, Mayco, Toro Stone, Diamond Products, Generac Magnum, Airman, Haulotte, Barreto, Power Blanket, Nifty Lift, Atlas Copco, Chicago Pneumatic, Allmand, Miller Curber, Skyjack, Lull, Skytrak, Tsurumi, Husquvarna Target, Stow, Wacker, Sakai, Mi-T-M, Sullair, Basic, Dynapac, MBW, Weber, Bartell, Bennar Newman, Haulotte, Ditch Runner, Menegotti, Morrison, Contec, Buddy, Crown, Edco, Wyco, Bomag, Laymor, EZ Trench, Bil-Jax, F.S. Curtis, Gehl Pavers, Heli, Honda, ICS/PowerGrit, IHI, Partner, Imer, Clipper, MMD, Koshin, Rice, CH&E, General Equipment, Amida, Coleman, NAC, Gradall, Square Shooter, Kent, Stanley, Tamco, Toku, Hatz, Kohler, Robin, Wisconsin, Northrock, Oztec, Toker TK, Rol-Air, APT, Wylie, Ingersoll Rand / Doosan, Innovatech, Con X, Ammann, Mecalac, Makinex, Smith Surface Prep, Small Line, Wanco, Yanmar

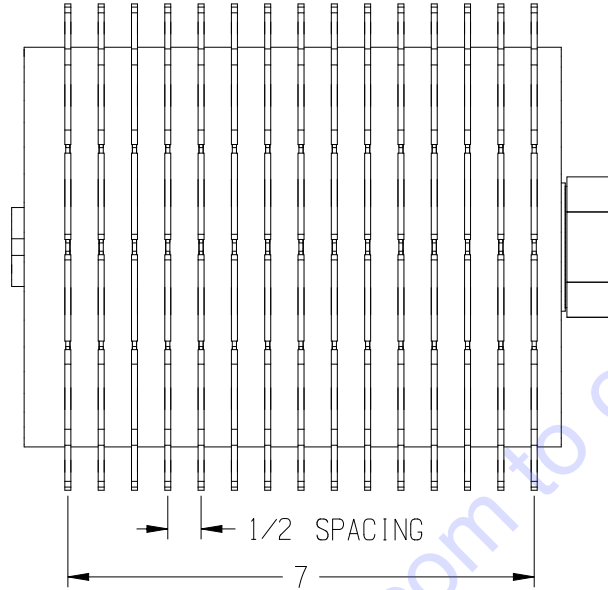
**1/2" DIAMOND GROOVING HEAD SET-UP
WITH 3/32" THICK BLADES**

E-CPM8-PL-0119

1/2" CENTER-TO-CENTER SPACING

(QTY. 15) 39808 .090"THK BLADES

(QTY. 14) 65073 .430"THK SPACERS

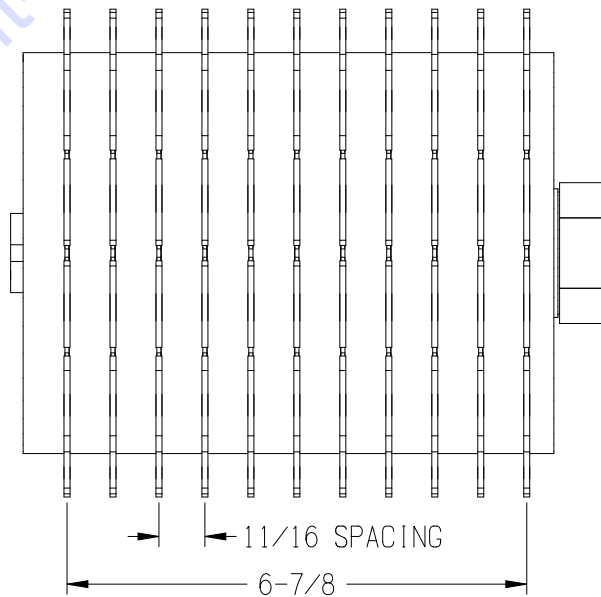


**11/16" DIAMOND GROOVING HEAD SET-UP
WITH 3/32" THICK BLADES**

11/16" CENTER-TO-CENTER SPACING

(QTY. 11) 39808 .090"THK BLADES

(QTY. 10) 65078 .625"THK SPACERS

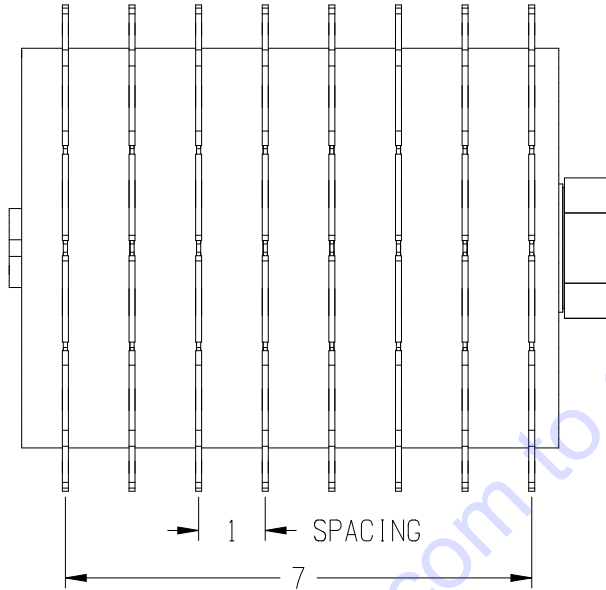


**1" DIAMOND GROOVING HEAD SET-UP
WITH 3/32" THICK BLADES**

1" CENTER-TO-CENTER SPACING

(QTY. 8) 39808 .090"THK BLADES

(QTY. 7) 65074 .930"THK SPACERS



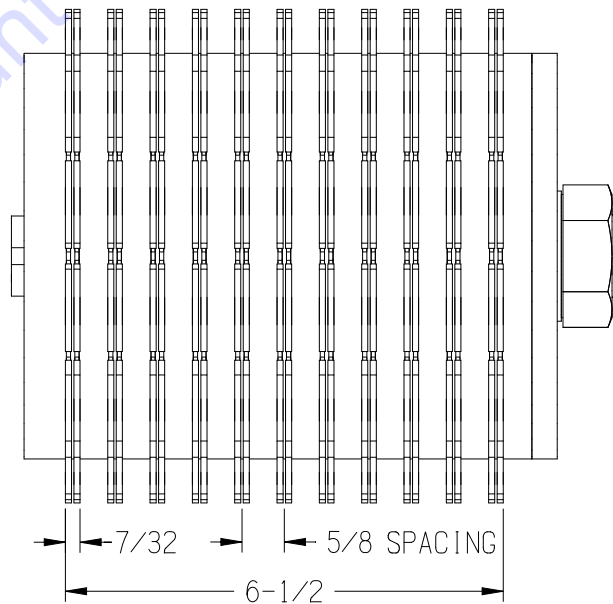
**5/8" DIAMOND GROOVING HEAD SET-UP
WITH 3/32" THICK BLADES (PAIRED)**

5/8" CENTER-TO-CENTER SPACING

(QTY. 22) 39808 .090"THK BLADES

(QTY. 11) 65072 .063"THK SPACERS (BETWEEN BLADES)

(QTY. 11) 65073 .430"THK SPACERS (BETWEEN PAIRS)

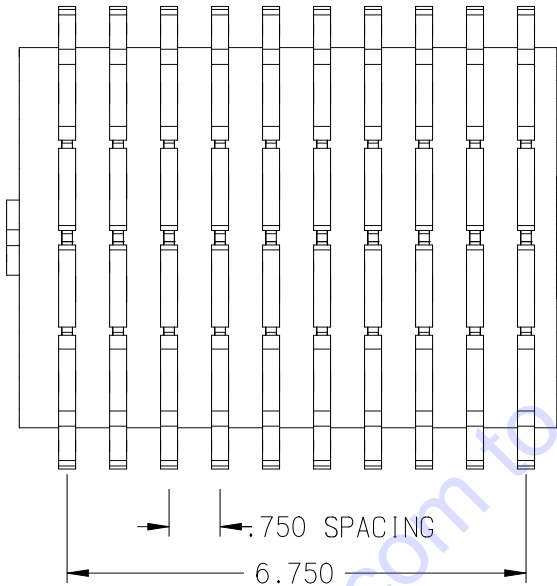


**3/4" DIAMOND GROOVING HEAD SET-UP
WITH 1/4" THICK BLADES**

3/4" CENTER-TO-CENTER SPACING

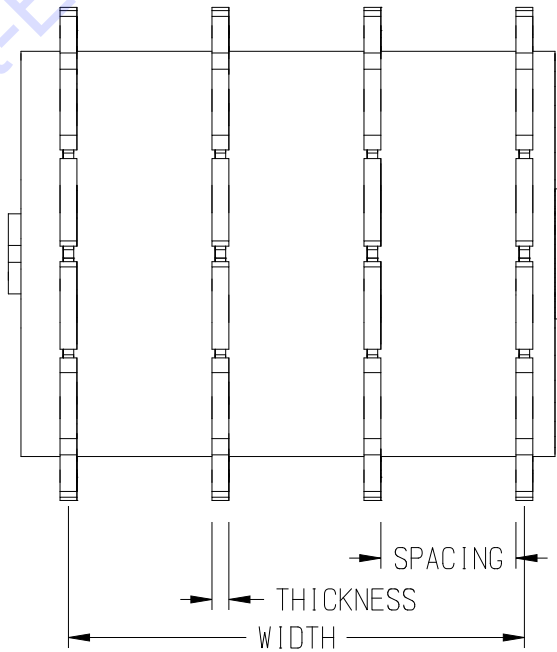
(QTY. 10) 39806 .250"THK BLADES

(QTY. 9) 65155 .594"THK SPACERS

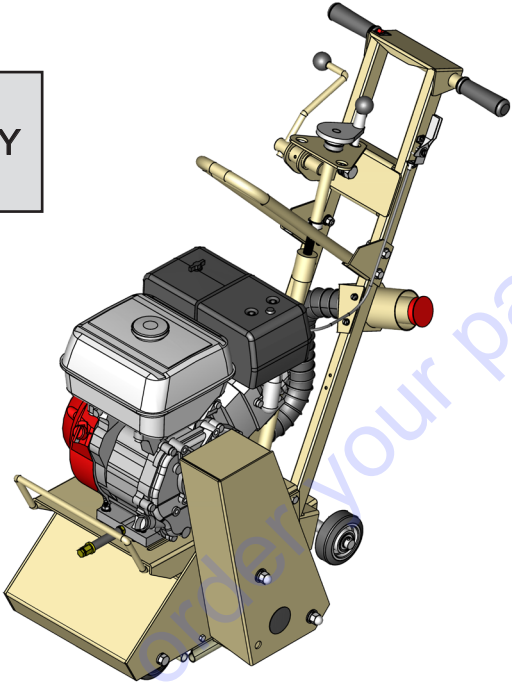
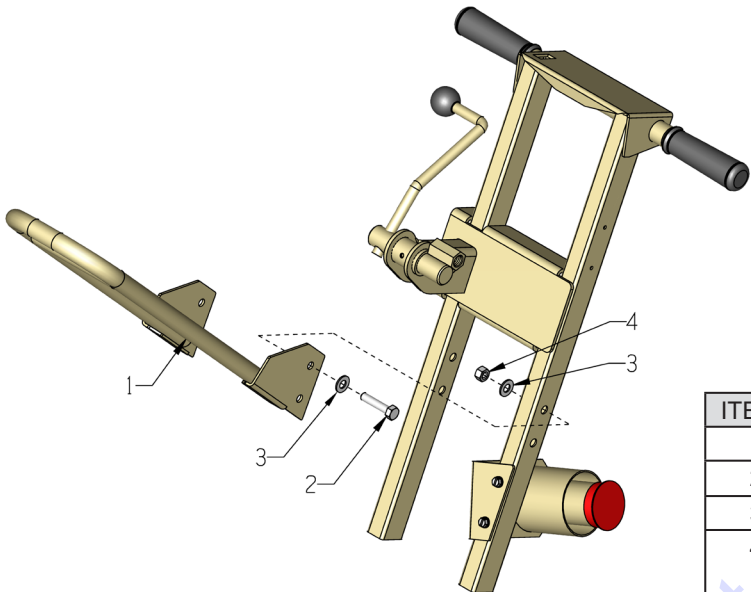


**CUSTOM SET-UPS CAN BE
CREATED UPON REQUEST**

Specify spacing, thickness and a width that is 7 inches or less as shown below.

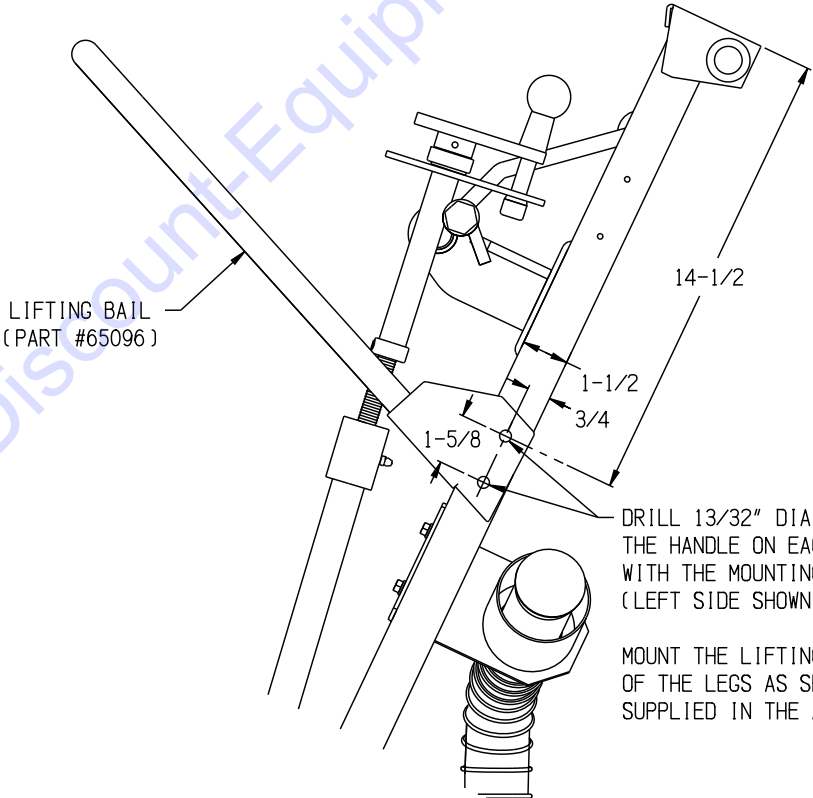


**ILLUSTRATION 10:
OPTIONAL LIFTING BAIL ASSEMBLY
PART # 65096A**



ITEM #	PART #	DESCRIPTION	QTY.
1	65096	BAIL ONLY, LIFTING	1
2	10029	SCREW, CAP 3/8-24 X 1-3/4	4
3	10025	WASHER, FLAT 3/8 SAE ZINC	8
4	10058	NUT, HEX LOCK 3/8-24 W/ NYLON PATCH	4

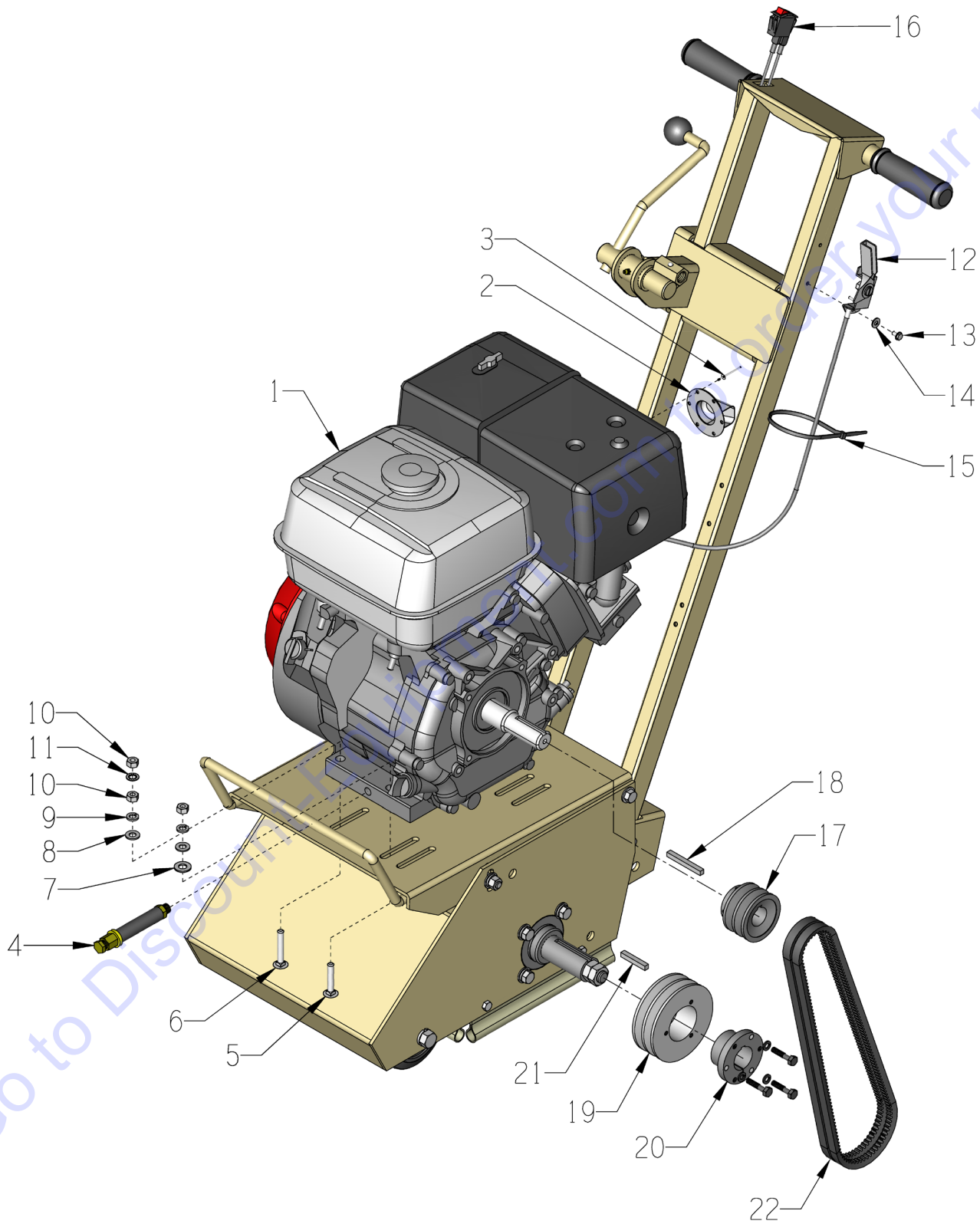
INSTRUCTIONS FOR MOUNTING LIFTING BAIL



DRILL 13/32" DIA. HOLES THROUGH THE HANDLE ON EACH SIDE TO MATCH WITH THE MOUNTING BRKTS. (LEFT SIDE SHOWN)

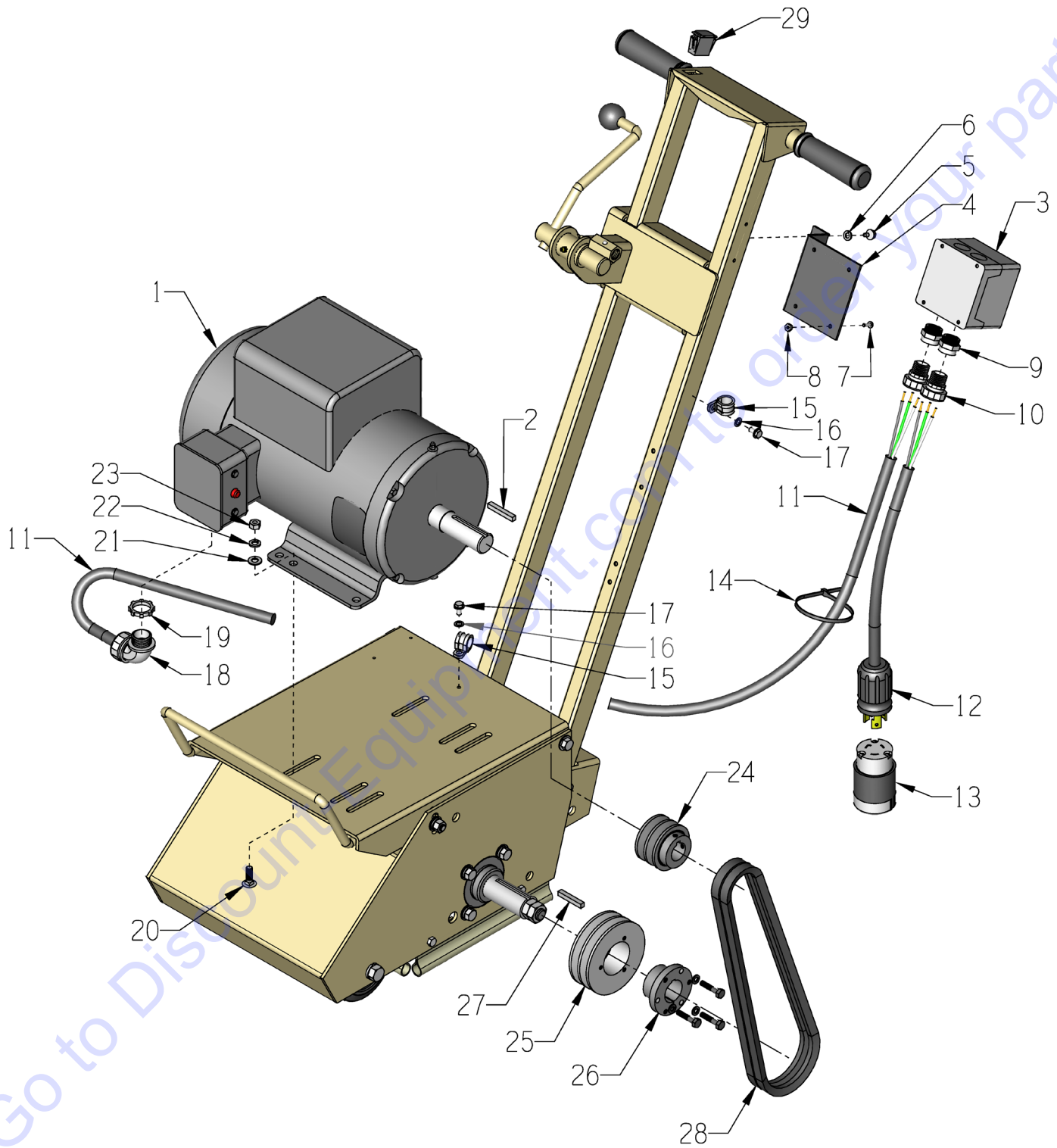
MOUNT THE LIFTING BAIL ON THE OUTSIDE OF THE LEGS AS SHOWN WITH THE HARDWARE SUPPLIED IN THE ASSEMBLY.

ILLUSTRATION 11: ENGINE GROUPING



PARTS LISTING - ILLUSTRATION 11: ENGINE GROUPING			
ITEM #	PART #	DESCRIPTION	QTY.
1	15027	ENGINE, HONDA GX270UT2QC9	1
2	10625	MUFFLER CAP, HONDA #18331-ZE3-811	1
3	10128	RIVET, BLIND 1/8 X .250L X .262HD	2
4	40328	OIL DRAIN KIT, 9/11/13 HP HONDA	1
5	10918	BOLT, CARRIAGE 5/16-18 X 1-3/4	3
6	10056	BOLT, CARRIAGE 5/16-18 X 2	1
7	10025	WASHER, FLAT 3/8 SAE ZINC	1
8	10213	WASHER, FLAT 5/16 SAE ZINC	4
9	10801	WASHER, LOCK 5/16 ZINC	4
10	10054	NUT, HEX 5/16-18 ZINC	5
11	10452	WASHER, LOCK, INT. TOOTH 5/16"	1
12	40388	CABLE, THROTTLE, LEVER-TYPE 24"	1
13	10877	SCREW, CAP STSHW 10-24 X 1/2	2
14	10831	WASHER, LOCK, INT. TOOTH #10	2
15	10982	TIE, CABLE, BLACK NYLON 11-1/4"	1
16	15201A	SWITCH W/ WIRES, ROCKER RED ON-OFF ADDITIONAL PARTS REQ'D. (NOT SHOWN):	1
	10968	TERM., RING 5/16 16-14GA. INSULATED	1
	10970	CONN., WIRE QUICK-SPLICE 18-14 GA.	1
17	10553	SHEAVE 2.5"OD X 2GR.A X 1"BORE	1
18	10307	KEY 1/4SQ X 2-1/4	1
19	65045	SHEAVE 4.05"OD X 2GR.A X SH	1
20	10505	BUSHING, SHEAVE SH X 1-1/4"BORE	1
21	40317	KEY 1/4SQ X 1-5/8	1
22	81007	BELT AX-33	2

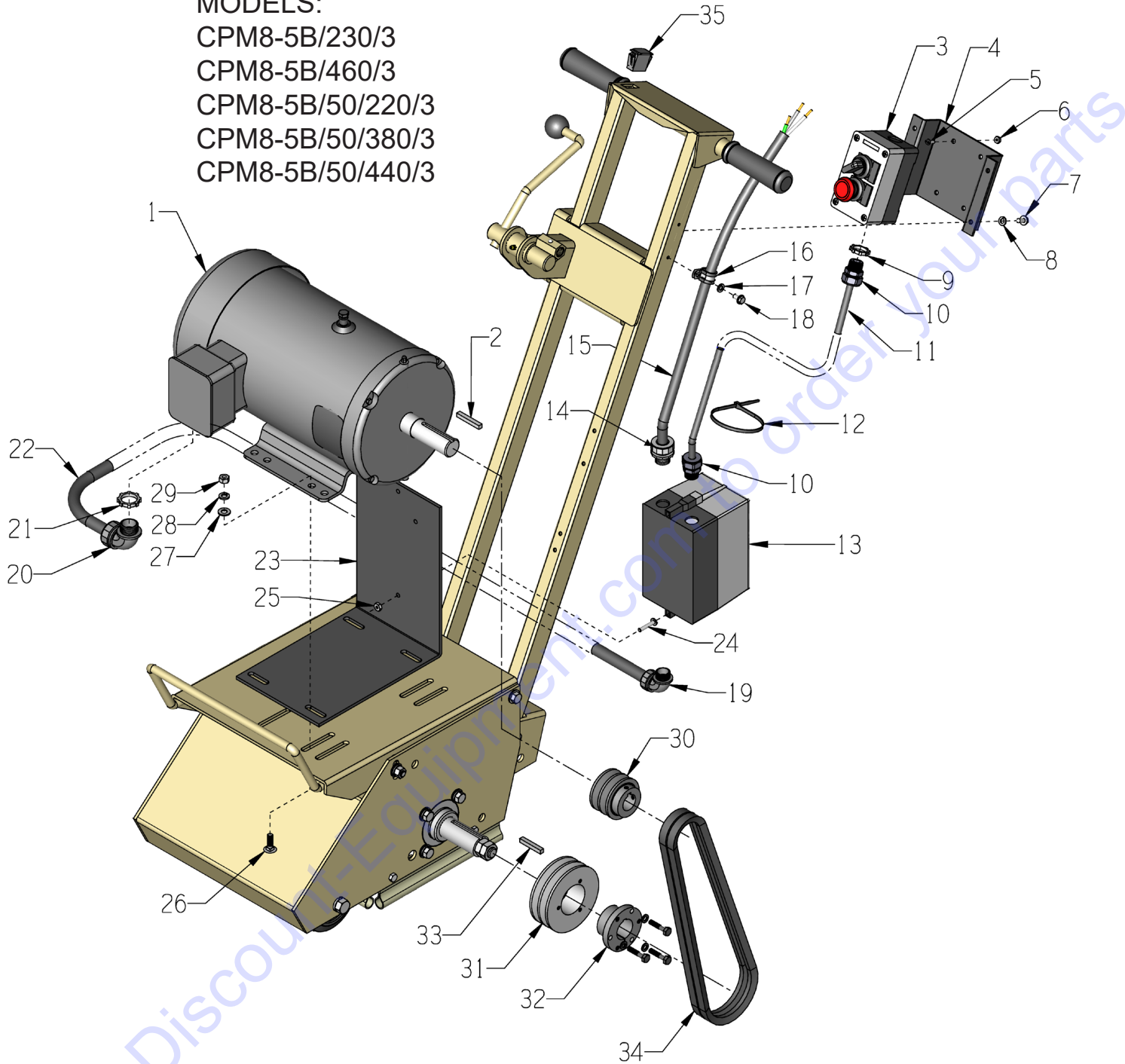
ILLUSTRATION 12: SINGLE PHASE MOTOR GROUPING



PARTS LISTING - ILLUSTRATION 12: SINGLE PHASE MOTOR GROUPING			
ITEM #	PART #	DESCRIPTION	QTY.
1	81026	MOTOR, BALDOR 5HP-1PH 60HZ 3450RPM	1
		REPLACEMENT PARTS:	
	16121	CAPACITOR, START, BALDOR EC1161C06SP	2
	16164	CAPACITOR, RUN, BALDOR #OC3040F09SP	1
	16540	THERMAL PROT. (RESET BUTTON) TPBRT25DB	1
2	----	KEY 1/4"SQ. X 1-3/4 (INCLUDED W/ MOTOR)	1
3	77043	SWITCH, ROTARY CAM ON/OFF	1
4	77042	BRACKET, ROTARY CAM SWITCH	1
5	10846	SCREW, CAP STSHW 1/4-20 X 1/2	2
6	10038	WASHER, LOCK 1/4 ZINC	2
7	11663	SCREW, MACHINE 8-32 X 1/2 (LOCATED INSIDE OF SWITCH BOX)	4
8	10462	NUT, KEPS LOCK 8-32 ZINC	4
9	77043-1	SWITCH ADAPTER, PG16 TO 1/2"NPT	2
10	41130	STRAIN RELIEF 1/2NPT X .550-.650"	2
11	65137	WIRE HARNESS 10/3 X 60"LOA	1
12	56321	PLUG W/ 10/3 CORD, LOCKING L6-30P	1
13	56322	CONNECTOR, LOCKING 30A/250V L6-30C	1
14	10982	TIE, CABLE, BLACK NYLON 11-1/4"	1
15	11565	CLAMP, LOOM, 5/8" (SAE SIZE 10)	2
16	10831	WASHER, LOCK, INT. TOOTH #10	2
17	10877	SCREW, CAP STSHW 10-24 X 1/2	2
18	16539	STRAIN RELIEF 90D X 3/4NPT .50-.625	1
19	10740	CONDUIT LOCK NUT 3/4 NP (LOCATED INSIDE OF JUNCTION BOX)	1
20	10819	BOLT, CARRIAGE 5/16-18 X 1 FULL THD	4
21	10213	WASHER, FLAT 5/16 SAE ZINC	4
22	10801	WASHER, LOCK 5/16 ZINC	4
23	10054	NUT, HEX 5/16-18 ZINC	4
24	10555	SHEAVE 2.5"OD X 2GR.A X 1-1/8"BORE	1
25	65045	SHEAVE 4.05"OD X 2GR.A X SH	1
26	10505	BUSHING, SHEAVE SH X 1-1/4"BORE	1
27	40317	KEY 1/4SQ X 1-5/8	1
28	10239	BELT A-32	2
29	15204	PLUG, RECT. HOLE, PLASTIC SNAP-IN	1

ILLUSTRATION 13: THREE PHASE MOTOR GROUPING

MODELS:
 CPM8-5B/230/3
 CPM8-5B/460/3
 CPM8-5B/50/220/3
 CPM8-5B/50/380/3
 CPM8-5B/50/440/3



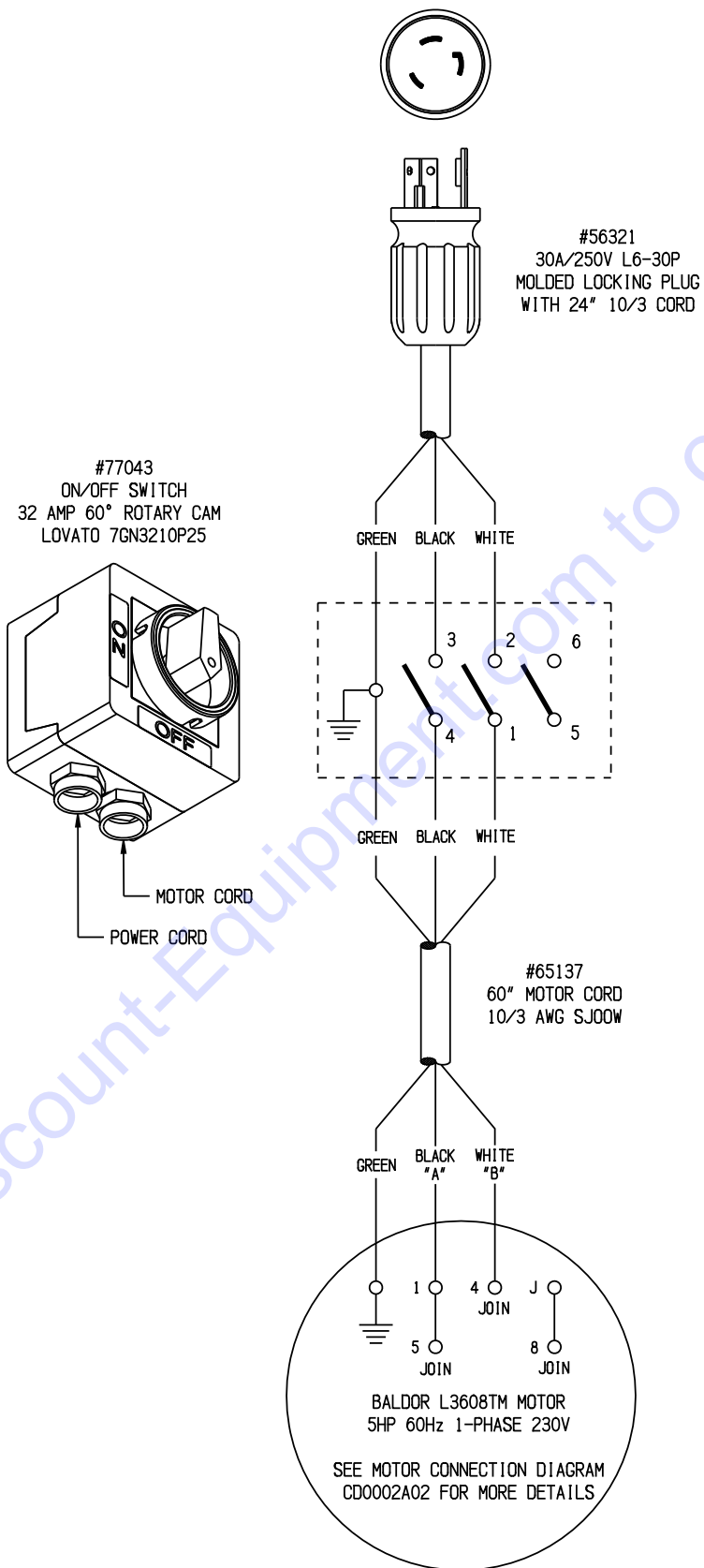
PARTS LISTING - ILLUSTRATION 12: THREE PHASE MOTOR GROUPING			
ITEM #	PART #	DESCRIPTION	QTY.
1	81022	MOTOR, BALDOR 5HP-3PH-60HZ-230/460V	1
	16020	MOTOR, BALDOR 5HP-3PH-50HZ-230/400V	1
2	----	KEY 1/4"SQ X 1-3/4 (INCLUDED W/ MOTOR)	1
3	16660	SWITCH BOX COMPLETE, ON/OFF/E-STOP ... INCLUDES:	1
	16661	ENCLOSURE, 2 HOLE ACI PBE2	1
	16662	LEGEND PLATE, EMER.STOP - BLACK	1
	16663	LEGEND PLATE, OFF/ON	1
	16664	MUSHROOM BUTTON, RED, 1NO+1NC	1
	16665	KNOB TYPE SELECTOR SWITCH, BLACK	1

PARTS LISTING CONTINUED - ILLUS. 13: THREE PHASE MOTOR GROUPING			
ITEM #	PART #	DESCRIPTION	QTY.
4	65088	BRACKET, REMOTE SWITCH, CPM-8	1
5	11663	SCREW, MACHINE 8-32 X 1/2 RHCD ZINC	4
6	10462	NUT, KEPS LOCK 8-32 ZINC	4
7	10846	SCREW, CAP STSHW 1/4-20 X 1/2	4
8	10038	WASHER, LOCK 1/4 ZINC	4
9	10790	CONDUIT LOCK NUT 1/2 NP (LOCATED INSIDE BOX)	1
10	16190	STRAIN RELIEF 1/2NPT X .250-.350"	2
11	65140	WIRE HARNESS 16/2 X 48"LOA	1
12	10982	TIE, CABLE, BLACK NYLON 11-1/4"	3
13	16604	STARTER ACI #128844 RESET ONLY 11.3-16A (230V)	1
	16458	STARTER ACI #128846 RESET ONLY 5.5-7.5A (460V)	1
	16476	STARTER ACI RESET ONLY 7.2-10A (50Hz-380V)	1
		REPLACEMENT PARTS:	
	16653	STARTER BOX ONLY, RESET	1
	16617	STARTER CONT./COIL ACI SK18.310-230	1
	16618	STARTER CONT./COIL ACI SK18.310-460	1
	16622	STARTER AC COIL 200/240V-60HZ, 190/220-50HZ	1
	16623	STARTER AC COIL 440/480V-60HZ, 380/415-50HZ	1
	16632	STARTER OVERLOAD RELAY 5.5-7.5 AMP	1
16633	STARTER OVERLOAD RELAY 7.2-10.0 AMP	1	
16635	STARTER OVERLOAD RELAY 11.3-16.0 AMP	1	
14	41053	STRAIN RELIEF 1/2NPT X .625-.750"	1
15	65105	WIRE HARNESS 10/4 X 48"LOA, CPM-8	1
16	11565	CLAMP, LOOM, 5/8" (SAE SIZE 10)	1
17	10831	WASHER, LOCK, INT. TOOTH #10	1
18	10877	SCREW, CAP STSHW 10-24 X 1/2	1
19	11621	STRAIN RELIEF 90D X 1/2NPT .625-.75	1
20	16539	STRAIN RELIEF 90D X 3/4NPT .50-.625	1
21	10740	CONDUIT LOCK NUT 3/4 NP (LOCATED INSIDE BOX)	1
22	65108	WIRE HARNESS 10/4 X 32"LOA	1
23	65087	MOUNT, STARTER	1
24	11732	SCREW, MACHINE 10-32 X 1-3/4 RPH	2
	10384	SCREW, MACHINE 10-32 X 1 RHP	1
25	10832	NUT, KEPS LOCK 10-32 ZINC	3
26	10820	BOLT, CARRIAGE 5/16-18 X 1-1/4 F.T.	4
27	10213	WASHER, FLAT 5/16 SAE ZINC	4
28	10801	WASHER, LOCK 5/16 ZINC	4
29	10054	NUT, HEX 5/16-18 ZINC	4
30	10555	SHEAVE 2.5"OD X 2GR.A X 1-1/8"BORE (60Hz MOTOR)	1
	10526	SHEAVE 3"OD X 2GR.A X 1-1/8"BORE (50Hz MOTOR)	1
31	65045	SHEAVE 4.05"OD X 2GR.A X SH	1
32	10505	BUSHING, SHEAVE SH X 1-1/4"BORE	1
33	40317	KEY 1/4SQ X 1-5/8	1
34	10239	BELT A-32	2
35	15204	PLUG, RECT. HOLE, PLASTIC SNAP-IN	1

SINGLE PHASE MODEL: CPM8-5B/230/1

WIRING DIAGRAM FOR ROTARY CAM SWITCH

60Hz 1-PHASE 230V

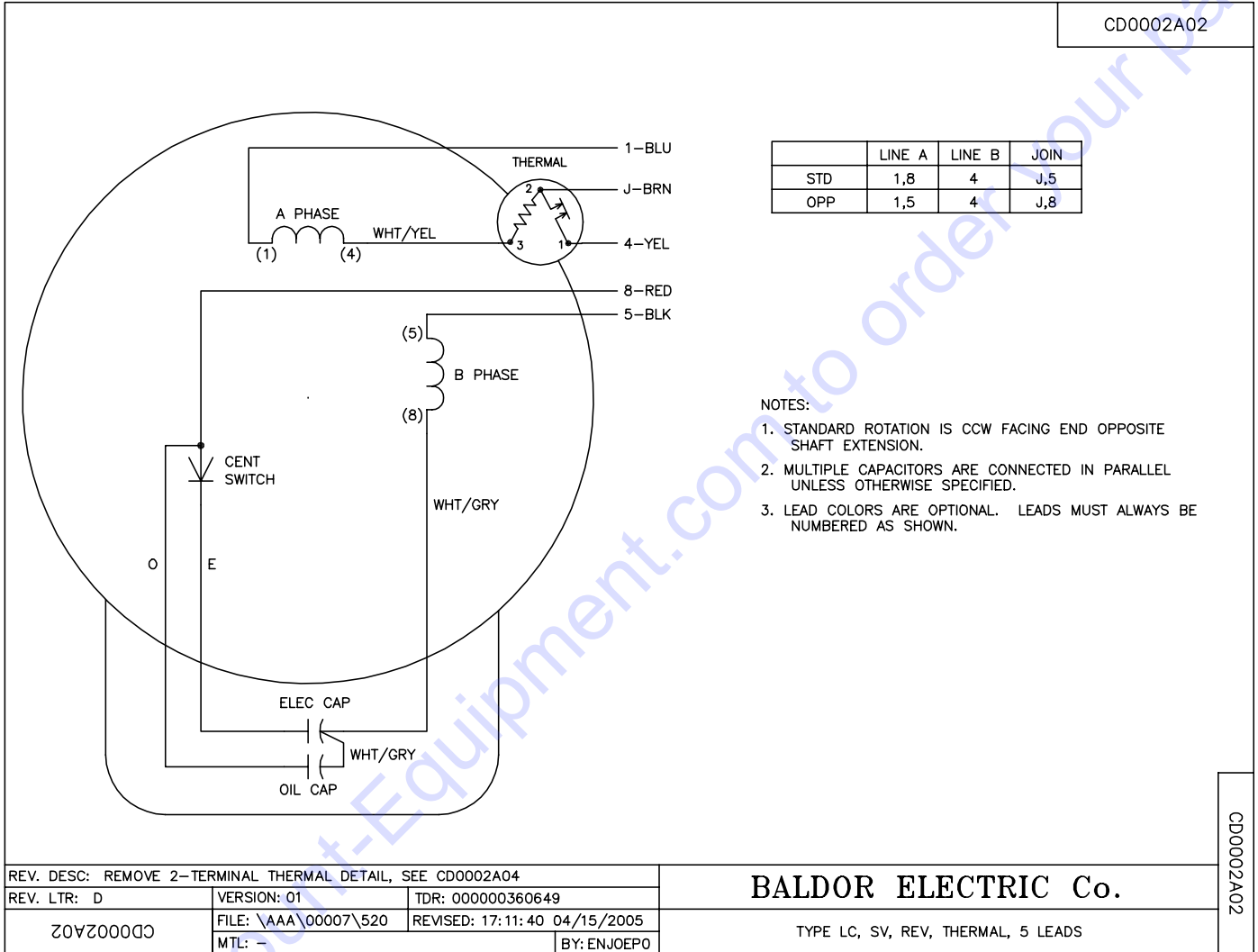


WIRING DIAGRAM FOR 60Hz 1-PHASE MOTOR

BALDOR CAT. NO. L3608TM
 5 H.P., 1 PHASE, 60 HERTZ, 3450 RPM,
 230 VOLT, 19.5 FULL LOAD AMPS

USE CONNECTIONS FOR OPPOSITE ROTATION SHOWN BELOW
 LINE "A" IS BLACK WIRE, LINE "B" IS WHITE WIRE

CD0002A02



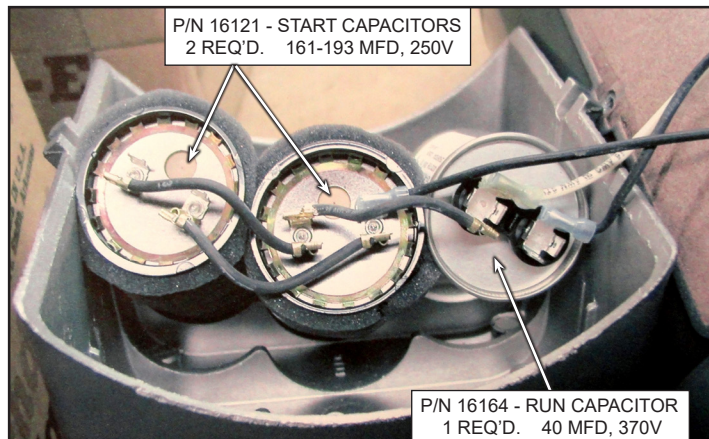
CD0002A02

REV. DESC: REMOVE 2-TERMINAL THERMAL DETAIL, SEE CD0002A04		
REV. LTR: D	VERSION: 01	TDR: 000000360649
Z0VZ00000	FILE: \AAA\00007\520	REVISED: 17:11:40 04/15/2005
CD0002A02	MTL: -	BY: ENJOEPO

BALDOR ELECTRIC Co.

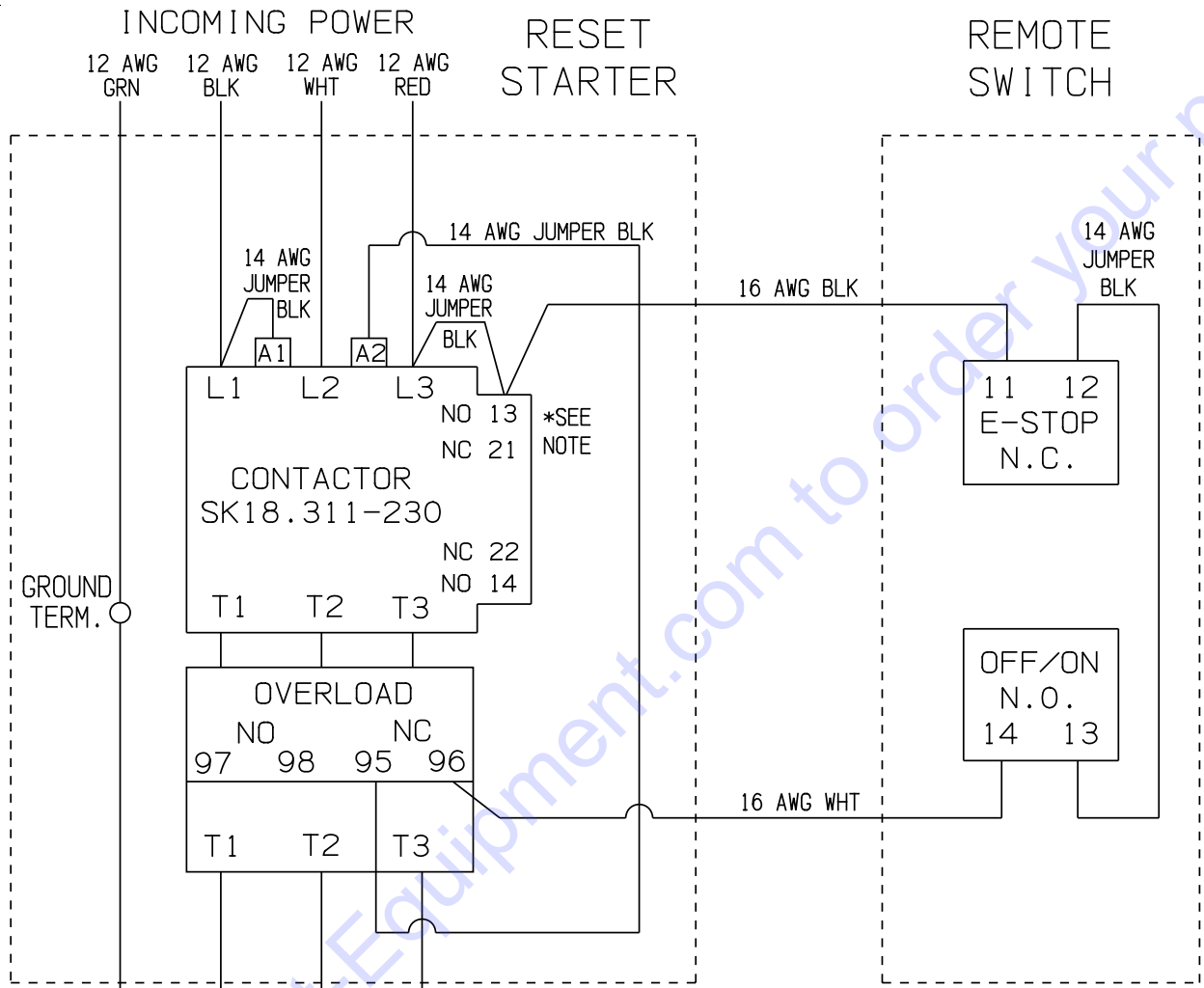
TYPE LC, SV, REV, THERMAL, 5 LEADS

CAPACITOR WIRING DETAIL

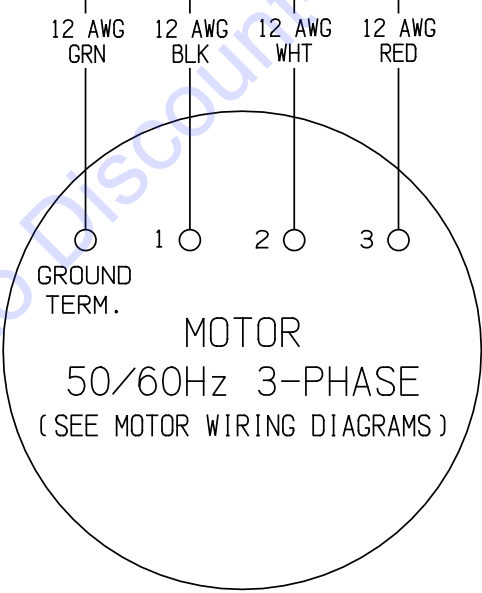


THREE PHASE MODELS: CPM8-5B/230/3, CPM8-5B/460/3, CPM8-5B/50/220/3, CPM8-5B/50/380/3 & CPM8-5B/50/440/3

WIRING DIAGRAM FOR STARTER & REMOTE SWITCH



*NOTE:
 TERMINAL 21 IS LOCATED ON TOP.
 BE SURE THE WIRES ARE CONNECTED
 TO TERMINAL 13 WHICH IS BELOW 21.



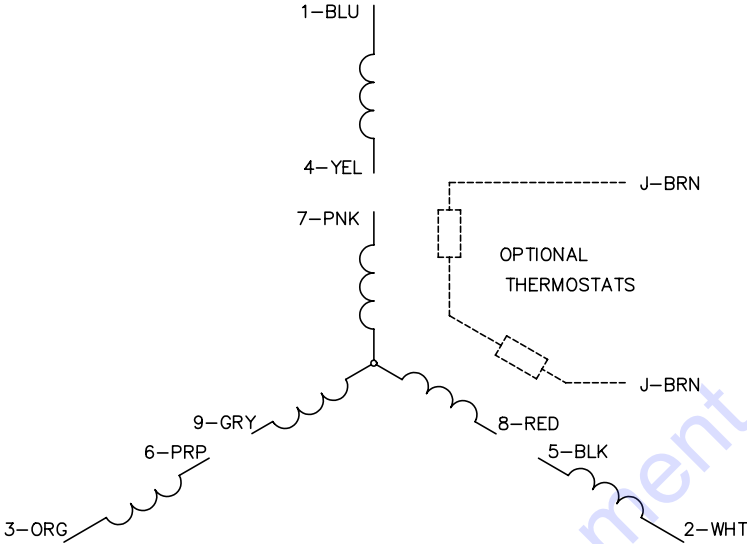
COLOR CODES	
BLK	= BLACK
GRN	= GREEN
RED	= RED
WHT	= WHITE

MODELS: CPM8-5B/230/3 & CPM8-5B/460/3

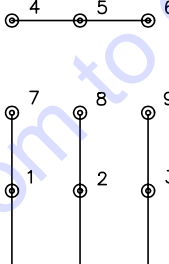
WIRING DIAGRAM FOR 60Hz 3-PHASE MOTOR

BALDOR CAT. NO. EM3613T
5 H.P., 3 PHASE, 60 HERTZ, 3450 RPM,
230/460 VOLTS, 12/6 FULL LOAD AMPS

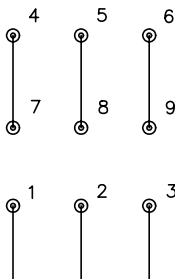
CD0005



LOW VOLTAGE (2Y)



HIGH VOLTAGE (1Y)



- NOTES:
1. INTERCHANGE ANY TWO LINE LEADS TO REVERSE ROTATION.
 2. OPTIONAL THERMOSTATS ARE PROVIDED WHEN SPECIFIED.
 3. ACTUAL NUMBER OF INTERNAL PARALLEL CIRCUITS MAY BE A MULTIPLE OF THOSE SHOWN ABOVE.
 4. LEAD COLORS ARE OPTIONAL. LEADS MUST ALWAYS BE NUMBERED AS SHOWN.

CD0005

REV. DESC: REVISE TO SHOW OPTIONAL COLORS			
REV. LTR: E	BY: JLP	REVISED: 01/19/99 10:15	TDR: 0171435
G00000		FILE: AAA00005140	MDL: -
		MTL: -	

BALDOR ELECTRIC Co.

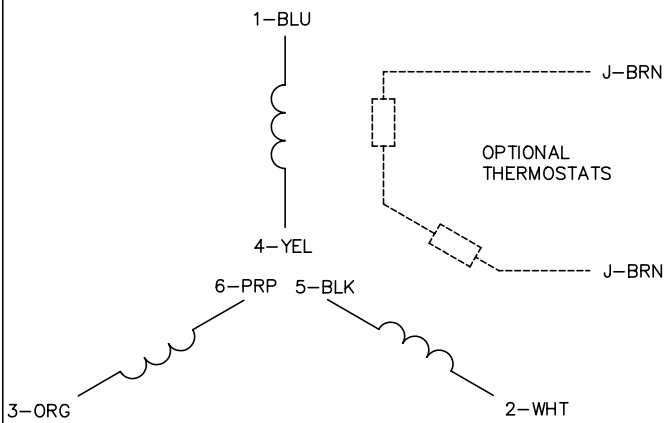
3PH, DV, 9 LEADS

MODEL CPM8-5B/50

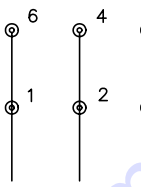
WIRING DIAGRAM FOR 50Hz 3-PHASE MOTOR

BALDOR CAT. NO. EM3613T-57
 5 H.P., 3 PHASE, 50 HERTZ

CD0022

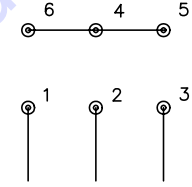


LOW VOLTAGE (1D)



LINE

HIGH VOLTAGE (1Y)



LINE

NOTES:

1. INTERCHANGE ANY TWO LINE LEADS TO REVERSE ROTATION.
2. OPTIONAL THERMOSTATS ARE PROVIDED WHEN SPECIFIED.
3. ACTUAL NUMBER OF INTERNAL PARALLEL CIRCUITS MAY BE A MULTIPLE OF THOSE SHOWN ABOVE.
4. LEAD COLORS ARE OPTIONAL. LEADS MUST ALWAYS BE NUMBERED AS SHOWN.

REV. DESC: REVISE TO SHOW OPTIONAL COLORS			
REV. LTR: F	BY: JLP	REVISED: 01/21/99 3:54	TDR: 0171435
ZZ0022		FILE: AAA0005144	MDL: -
		MTL: -	

BALDOR ELECTRIC Co.

3PH, DV, 6 LEADS, DELTA/WYE CONNECTION

CD0022

MODEL CPM8-9H

WIRING DIAGRAM FOR HONDA ENGINE

ON-OFF ROCKER SWITCH
P/N 15201A
(LOCATED ON HANDLE)

WIRE COLORS
BL = BLACK
R = RED
Y = YELLOW

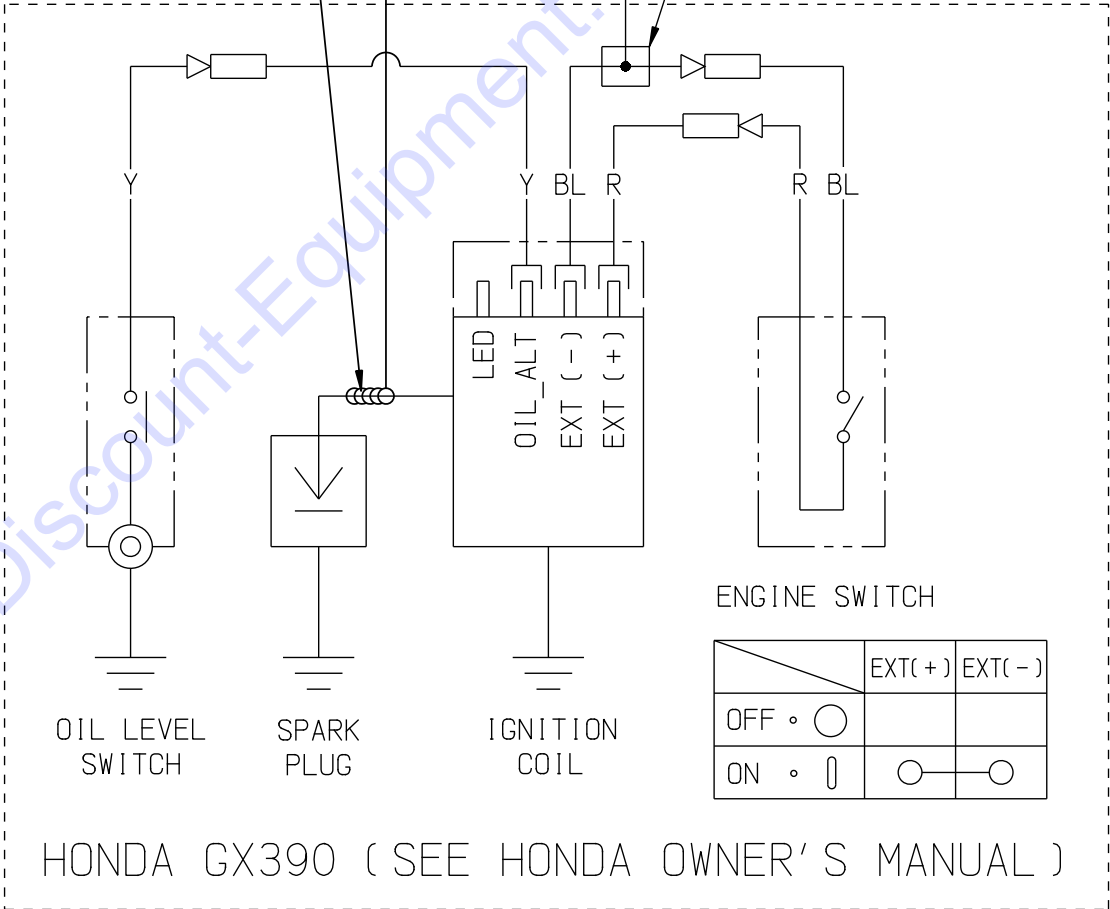
HOUR METER
P/N 15138
(OPTIONAL)

ON OFF

TERM. # 1 CENTER TERM.

WRAP 4 OR 5
TIMES & SECURE
WITH TIE WRAP

QUICK-SPLICE
WIRE CONNECTOR
P/N 10970



PARTS FINDER

**Search Website
by Part Number**



**Search Manual
Library For Parts
Manual & Lookup Part
Numbers – Purchase
or Request Quote**

Search Manuals

Enter your information to help us find the right parts manual for your machine.

* Brand:

* Model:

* Serial:

* Part Number:

SEARCH

**Can't Find Part or
Manual? Request Help
by Manufacturer,
Model & Description**

Parts Order Form

Please fill in the following information to help us find the right part for your machine.

Manufacturer:	<input type="text"/>
Model:	<input type="text"/>
Description:	<input type="text"/>
Part Number:	<input type="text"/>
Quantity:	<input type="text"/>
Notes:	<input type="text"/>

Submit

Discount-Equipment.com is your online resource for quality parts & equipment.

Florida: **561-964-4949** Outside Florida TOLL FREE: **877-690-3101**

Need parts?

Click on this link: <http://www.discount-equipment.com/category/5443-parts/> and choose one of the options to help get the right parts and equipment you are looking for. Please have the machine model and serial number available in order to help us get you the correct parts. If you don't find the part on the website or on one of the online manuals, please fill out the request form and one of our experienced staff members will get back to you with a quote for the right part that your machine needs.

We sell worldwide for the brands: Genie, Terex, JLG, MultiQuip, Mikasa, Essick, Whiteman, Mayco, Toro Stone, Diamond Products, Generac Magnum, Airman, Haulotte, Barreto, Power Blanket, Nifty Lift, Atlas Copco, Chicago Pneumatic, Allmand, Miller Curber, Skyjack, Lull, Skytrak, Tsurumi, Husquvarna Target, Stow, Wacker, Sakai, Mi-T-M, Sullair, Basic, Dynapac, MBW, Weber, Bartell, Bennar Newman, Haulotte, Ditch Runner, Menegotti, Morrison, Contec, Buddy, Crown, Edco, Wyco, Bomag, Laymor, EZ Trench, Bil-Jax, F.S. Curtis, Gehl Pavers, Heli, Honda, ICS/PowerGrit, IHI, Partner, Imer, Clipper, MMD, Koshin, Rice, CH&E, General Equipment, Amida, Coleman, NAC, Gradall, Square Shooter, Kent, Stanley, Tamco, Toku, Hatz, Kohler, Robin, Wisconsin, Northrock, Oztec, Toker TK, Rol-Air, APT, Wylie, Ingersoll Rand / Doosan, Innovatech, Con X, Ammann, Mecalac, Makinex, Smith Surface Prep, Small Line, Wanco, Yanmar