

OPERATION AND PARTS MANUAL



www.Discount-Equipment.com

MODEL BPX GASOLINE BACKPACK VIBRATOR (HONDA GXH50UQXA GASOLINE ENGINE)

Revision #4 (05/27/21)



THIS MANUAL MUST ACCOMPANY THE EQUIPMENT AT ALL TIMES.

PN: 14454

TO PURCHASE THIS PRODUCT PLEASE CONTACT US



**Equipment Financing and
Extended Warranties Available**



**Discount-Equipment.com is your online resource for
commercial and industrial quality parts and equipment sales.**

561-964-4949

visit us on line @ www.discount-equipment.com

Select an option below to find your Equipment

Search by Manufacturer

Search by Product Type

Request a Quote

We sell worldwide for the brands: Genie, Terex, JLG, MultiQuip, Mikasa, Essick, Whiteman, Mayco, Toro Stone, Diamond Products, Generac Magnum, Airman, Haulotte, Barreto, Power Blanket, Nifty Lift, Atlas Copco, Chicago Pneumatic, Allmand, Miller Curber, Skyjack, Lull, Skytrak, Tsurumi, Husquvarna Target, Stow, Wacker, Sakai, Mi-T-M, Sullair, Basic, Dynapac, MBW, Weber, Bartell, Bennar Newman, Haulotte, Ditch Runner, Menegotti, Morrison, Contec, Buddy, Crown, Edco, Wyco, Bomag, Laymor, EZ Trench, Bil-Jax, F.S. Curtis, Gehl Pavers, Heli, Honda, ICS/PowerGrit, IHI, Partner, Imer, Clipper, MMD, Koshin, Rice, CH&E, General Equipment, Amida, Coleman, NAC, Gradall, Square Shooter, Kent, Stanley, Tamco, Toku, Hatz, Kohler, Robin, Wisconsin, Northrock, Oztec, Toker TK, Rol-Air, APT, Wylie, Ingersoll Rand / Doosan, Innovatech, Con X, Ammann, Mecalac, Makinex, Smith Surface Prep, Small Line, Wanco, Yanmar

WARNING

CALIFORNIA — Proposition 65 Warning

Engine exhaust and some of its constituents, and some dust created by power sanding, sawing, grinding, drilling and other construction activities contains chemicals known to the State of California to cause cancer, birth defects and other reproductive harm. Some examples of these chemicals are:

- Lead from lead-based paints.
- Crystalline silica from bricks.
- Cement and other masonry products.
- Arsenic and chromium from chemically treated lumber.

Your risk from these exposures varies, depending on how often you do this type of work. To reduce your exposure to these chemicals: **ALWAYS** work in a well ventilated area, and work with approved safety equipment, such as dust masks that are specially designed to filter out microscopic particles.

SILICOSIS/RESPIRATORY WARNINGS

⚠ WARNING



SILICOSIS WARNING

Grinding/cutting/drilling of masonry, concrete, metal and other materials with silica in their composition may give off dust or mists containing crystalline silica. Silica is a basic component of sand, quartz, brick clay, granite and numerous other minerals and rocks. Repeated and/or substantial inhalation of airborne crystalline silica can cause serious or fatal respiratory diseases, including silicosis. In addition, California and some other authorities have listed respirable crystalline silica as a substance known to cause cancer. When cutting such materials, always follow the respiratory precautions mentioned above.

⚠ WARNING

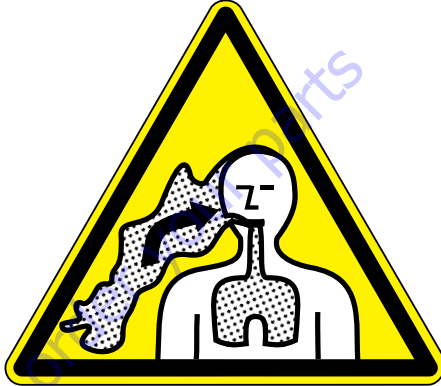

RESPIRATORY HAZARDS

Grinding/cutting/drilling of masonry, concrete, metal and other materials can generate dust, mists and fumes containing chemicals known to cause serious or fatal injury or illness, such as respiratory disease, cancer, birth defects or other reproductive harm. If you are unfamiliar with the risks associated with the particular process and/or material being cut or the composition of the tool being used, review the material safety data sheet and/or consult your employer, the material manufacturer/supplier, governmental agencies such as OSHA and NIOSH and other sources on hazardous materials. California and some other authorities, for instance, have published lists of substances known to cause cancer, reproductive toxicity, or other harmful effects.

Control dust, mist and fumes at the source where possible. In this regard use good work practices and follow the recommendations of the manufacturers or suppliers, OSHA/NIOSH, and occupational and trade associations. Water should be used for dust suppression when wet cutting is feasible. When the hazards from inhalation of dust, mists and fumes cannot be eliminated, the operator and any bystanders should always wear a respirator approved by NIOSH/MSHA for the materials being used.

TABLE OF CONTENTS

Multiquip BPX Gasoline Concrete Vibrator

Proposition 65 Warning	2
Silicosis/Respiratory Warnings	3
Table Of Contents	4
Parts Ordering Procedures.....	5
Safety Information	6-9
Specifications	10
Dimensions.....	11
General Information.....	12
Components	13-14
Set-Up	15-17
Inspection	18
Operation.....	19-24
Maintenance	25-28
Troubleshooting	29
Explanation Of Code In Remarks Column.....	30
Suggested Spare Parts	31

Component Drawings

Nameplate And Decals Assembly.....	32-33
Vibrator Assembly.....	34-35
Frame And Swivel Assembly	36-37
Engine Mounting Assembly	38-39
Engine Service Parts Assembly.....	40-41

NOTICE

Specifications and part numbers are subject to change without notice.

SAFETY INFORMATION

Do not operate or service the equipment before reading the entire manual. Safety precautions should be followed at all times when operating this equipment. Failure to read and understand the safety messages and operating instructions could result in injury to yourself and others.

This operation manual has been developed to provide complete instructions for the safe and efficient operation of the Multiquip Model BPX Gasoline Backpack Vibrator. Refer to the engine manufacturer's instructions for data relative to its safe operation. **Before using this vibrator, ensure that the operating individual has read and understood all instructions in this manual.** This vibrator, other property, or the surrounding environment could be damaged if you do not follow instructions.

SAFETY MESSAGES

The four safety messages shown below will inform you about potential hazards that could injure you or others. The safety messages specifically address the level of exposure to the operator and are preceded by one of four words: **DANGER**, **WARNING**, **CAUTION** or **NOTICE**.

DANGER

Indicates a hazardous situation which, if not avoided, **WILL** result in **DEATH** or **SERIOUS INJURY**.

WARNING

Indicates a hazardous situation which, if not avoided, **COULD** result in **DEATH** or **SERIOUS INJURY**.

CAUTION



Indicates a hazardous situation which, if not avoided, **COULD** result in **MINOR** or **MODERATE INJURY**.

NOTICE

Addresses practices not related to personal injury.

SAFETY SYMBOLS

Potential hazards associated with the operation of this equipment will be referenced with hazard symbols which may appear throughout this manual in conjunction with safety messages.

Symbol	Safety Hazard
	Lethal exhaust gas hazards
	Explosive fuel hazards
	Burn hazards
	Overspeed hazards

SAFETY INFORMATION

GENERAL SAFETY

CAUTION

- **NEVER** operate this equipment without proper protective clothing, shatterproof glasses, respiratory protection, hearing protection, steel-toed boots and other protective devices required by the job or city and state regulations.



- **NEVER** operate this equipment when not feeling well due to fatigue, illness or when under medication. 
- **NEVER** operate this equipment under the influence of drugs or alcohol.



- **ALWAYS** check the equipment for loosened threads or bolts before starting.
- **NEVER** operate vibrator around corrosive chemicals or water containing toxic substances. These fluids could create serious health and environmental hazards. Contact local authorities for assistance.
- **DO NOT** use the equipment for any purpose other than its intended purposes or applications.

NOTICE

- This equipment should only be operated by trained and qualified personnel 18 years of age and older.
- This equipment is for industrial use only.
- Whenever necessary, replace nameplate, operation and safety decals when they become difficult to read.
- Manufacturer does not assume responsibility for any accident due to equipment modifications. Unauthorized equipment modification will void all warranties. Any modification which could lead to a change in the original characteristics of the machine should be made only by the manufacturer who shall confirm that the machine is in conformity with appropriate safety regulations.

- **NEVER** use accessories or attachments that are not recommended by Multiquip for this equipment. Damage to the equipment and/or injury to user may result.

- **ALWAYS** know the location of the nearest fire extinguisher.



- **ALWAYS** know the location of the nearest first aid kit.



- **ALWAYS** know the location of the nearest phone or **keep a phone on the job site**. Also, know the phone numbers of the nearest **ambulance, doctor** and **fire department**. This information will be invaluable in the case of an emergency.

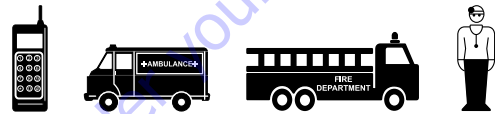

VIBRATOR SAFETY

DANGER

- **NEVER** operate the equipment in an explosive atmosphere, near combustible materials, or near flammable or low flash point fluids. An explosion or fire could result causing severe **bodily harm or even death**.



WARNING

- **NEVER** disconnect any **emergency or safety devices**. These devices are intended for operator safety. Disconnection of these devices can cause severe injury, bodily harm or even death. Disconnection of any of these devices will void all warranties.

- **NEVER** operate equipment with covers or guards removed. Keep **fingers, hands, hair**, and **clothing** away from all moving parts to prevent injury. Wear clothing that will not likely become caught in the equipment or snag on the forms.

CAUTION

- **ALWAYS** be sure the operator is familiar with proper safety precautions and operating techniques before using vibrator.
- **NEVER** leave the vibrator unattended. Turn off engine when unattended.

SAFETY INFORMATION

- **NEVER** lubricate components or attempt service on a running machine.
- **ALWAYS** allow the vibrator a proper amount of time to cool before servicing.

NOTICE

- **ALWAYS** keep the machine in proper running condition.
- **ALWAYS** become familiar with the components of the vibrator before operating.
- Fix damage to machine and replace any broken parts immediately.
- **ALWAYS** store equipment properly when it is not being used. Equipment should be stored in a clean, dry location out of the reach of children and unauthorized personnel.

ENGINE SAFETY

DANGER

- The engine fuel exhaust gases contain poisonous carbon monoxide. This gas is colorless and odorless, and can cause death if inhaled.
- The engine of this equipment requires an adequate free flow of cooling air. **NEVER** operate this equipment in any enclosed or narrow area where free flow of the air is restricted. If the air flow is restricted it will cause injury to people and property and serious damage to the equipment or engine. Remember the engine gives off **DEADLY** gases.



WARNING

- **NEVER** operate the engine with heat shields or guards removed.
- **DO NOT** remove the engine oil drain plug while the engine is hot. Hot oil will gush out of the engine crankcase and severely scald any persons in the general area of the vibrator.

CAUTION

- **NEVER** touch the hot exhaust manifold, muffler or cylinder. Allow these parts to cool before servicing equipment.



- **ALWAYS** place the engine **ON/OFF** switch in the **OFF** position when the vibrator is not in use.
- **NEVER** tamper with the factory settings of the engine or engine governor. Damage to the engine or equipment can result if operating in speed ranges above the maximum allowable.



NOTICE

- Refer to the *Engine Owner's Manual* for engine technical questions or information.
- **NEVER** run engine without an air filter or with a dirty air filter. Severe engine damage may occur. Service air filter frequently to prevent engine malfunction.
- State Health Safety Codes and Public Resources Codes specify that in certain locations, spark arresters must be used on internal combustion engines that use hydrocarbon fuels. A spark arrester is a device designed to prevent accidental discharge of sparks or flames from the engine exhaust. Spark arresters are qualified and rated by the United States Forest Service for this purpose. In order to comply with local laws regarding spark arresters, consult the engine distributor or the local Health and Safety Administrator.

FUEL SAFETY

DANGER

- **DO NOT** add fuel to equipment if it is placed inside truck bed with plastic liner. Possibility exists of explosion or fire due to static electricity.
- **DO NOT** start the engine near spilled fuel or combustible fluids. Gasoline fuel is extremely flammable and its vapors can cause an explosion if ignited.
- **ALWAYS** refuel in a well-ventilated area, away from sparks and open flames.
- **ALWAYS** use extreme caution when working with **flammable** liquids.
- **DO NOT** fill the fuel tank while the engine is running or hot.
- **DO NOT** overfill tank, since spilled fuel could ignite if it comes into contact with hot engine parts or sparks from the ignition system.

SAFETY INFORMATION

- Store fuel in appropriate containers, in well-ventilated areas and away from sparks and flames.
- **NEVER** use fuel as a cleaning agent.
- **DO NOT** smoke around or near the equipment. Fire or explosion could result from fuel vapors or if fuel is spilled on a hot engine.



TRANSPORTING

- **ALWAYS** shut down engine before transporting.
- Tighten fuel cap securely and close fuel cock to prevent fuel from spilling.
- **ALWAYS** use proper lifting techniques when using or moving the vibrator (backpack), flexible shaft, or vibrator assembly.

ENVIRONMENTAL SAFETY/DECOMMISSIONING

NOTICE

Decommissioning is a controlled process used to safely retire a piece of equipment that is no longer serviceable. If the equipment poses an unacceptable and unreparable safety risk due to wear or damage or is no longer cost effective to maintain (beyond life-cycle reliability) and is to be decommissioned (demolition and dismantlement), be sure to follow rules below.

- **ALWAYS** observe all applicable compulsory regulations relevant to environmental protection, especially fuel storage, the handling of hazardous substances, and the wearing of protective clothing and equipment. Instruct the user as necessary, or, as the user, request this information and training.
- Dispose of hazardous waste properly. Examples of potentially hazardous waste include used motor oil, fuel, and fuel filters.
- **DO NOT** use food or plastic containers to dispose of hazardous waste.

- **DO NOT** pour waste or oil directly onto the ground, down a drain or into any water source.
- Contact your country's Department of Public Works or recycling agency in your area and arrange for proper disposal of any electrical components, waste or oil associated with this equipment.



- When the life cycle of this equipment is over, remove battery (if equipped) and bring to appropriate facility for lead reclamation. Use safety precautions when handling batteries that contain sulfuric acid.
- When the life cycle of this equipment is over, it is recommended that the unit frame and all other metal parts be sent to a recycling center.

Metal recycling involves the collection of metal from discarded products and its transformation into raw materials to use in manufacturing a new product.

Recyclers and manufacturers alike promote the process of recycling metal. Using a metal recycling center promotes energy cost savings.

EMISSIONS INFORMATION

NOTICE

The gasoline engine used in this equipment has been designed to reduce harmful levels of carbon monoxide (CO), hydrocarbons (HC) and nitrogen oxides (NOx) contained in gasoline exhaust emissions.

This engine has been certified to meet US EPA Evaporative emissions requirements in the installed configuration.

Attempting to modify or make adjustments to the engine emission system by unauthorized personnel without proper training could damage the equipment or create an unsafe condition.

Additionally, modifying the fuel system may adversely affect evaporative emissions, resulting in fines or other penalties.

Emission Control Label

The emission control label is an integral part of the emission system and is strictly controlled by regulation(s).

The label must remain with the engine for its entire life.

If a replacement emission label is needed, please contact your authorized Honda Engine Distributor.

SPECIFICATIONS

Table 1. Honda Engine Specifications		
Engine	Model	Honda GXH50UQXA
	Type	4-Stroke, Single Cylinder, OHV, Gasoline Engine
	Bore x Stroke	1.65 in. x 1.42 in. (42 mm x 36 mm)
	Displacement	3.0 in ³ (49 cm ³)
	Max. Output	2.5 hp/7,000 rpm
	Fuel Tank Capacity	Approx. 0.32 U.S. gallons (1.2 liters)
	Fuel	Unleaded Gasoline Octane Rating of 86 or Higher
	Lube Oil Capacity	0.26 qt. (.25 liters)
	Spark Plug Type	NKG: CR5HSB Denso: U16FSR-UB
	Spark Plug Gap	0.024 – 0.028 in. (0.6 – 0.7 mm)
	Speed Control Method	Centrifugal Flyweight Type
	Starting Method	Recoil Start
Dimension (L x W x H)	8.9 x 10.8 x 13.9 in. (225 x 274 x 353 mm)	
Dry Net Weight (Engine)	12.1 lb. (5.5 kg)	
Operating Weight (Vibrator/Backpack)	31 lb. (14.1 kg)	

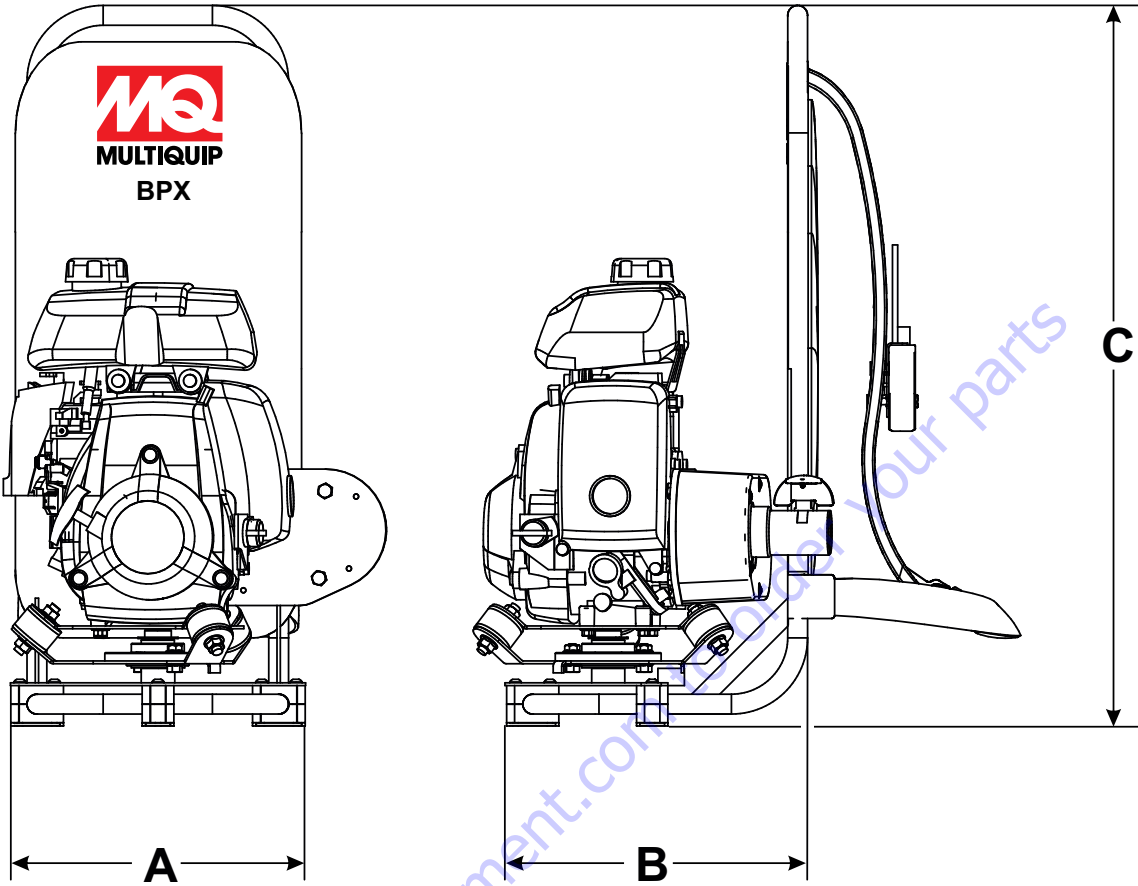

Figure 1. Vibrator Dimensions

Table 2. Vibrator Dimensions	
Reference Letter	Dimension in. (mm)
A	11.0 (280)
B	13.75 (349)
C	27.0 (686)

GENERAL INFORMATION

GENERAL INFORMATION

The BPX backpack vibrator utilizes a Honda GXH50 2.5-hp, 4-stroke, overhead-valve, single-cylinder, gasoline engine. The frame is mounted on three rubber isolators to help reduce engine vibration. The vibrator comes standard with a quick-disconnect coupling for easy removal of the flexible shaft.

CAUTION

When operating the BPX vibrator, **ALWAYS** wear rubber insulated gloves and boots. Safety glasses and ear protection are also recommended.

Tips

- Keep the bending radius of the flexible hose to a minimum during use.
- Avoid starting the unit with the vibrator head immersed in the concrete mix. After the engine has started, immerse the vibrator head into concrete mix.
- Excessive wear to the vibrating head can result from misuse. **DO NOT** allow the head to vibrate against already hardened concrete or steel used for reinforcement.
- **NEVER** drop or knock the vibrator head against any hard objects. This can damage the eccentric end bell assembly or bearings contained within the head.
- **ALWAYS** rinse or wipe off any wet concrete before it dries or hardens on any part of the unit (engine, shaft, or head).

WARNING

Before operating this gasoline-powered vibrator, the operator must **read** and **understand** the contents of the operation manual. Failure to read this manual may result in severe bodily harm and damage to the equipment.



Backpack Vibrator Theory

The purpose of this vibrator is to **consolidate** concrete by removing air pockets and voids.

The vibrator is designed to set the particles in fresh concrete in motion, thereby reducing friction and giving the mixture a mobile quality so that gravity and the displacement of entrapped air cause the concrete to settle easily into place.

By consolidating the concrete quickly, the vibrator allows stiffer mixes to be poured than would otherwise be possible.

Vibration also makes concrete more watertight, increases resistance to weathering, and creates a better bond between concrete and reinforcement.

Because vibration causes much of the entrapped air in concrete to rise to the surface, honeycombing is prevented. Vibration also eliminates most air pockets between the concrete and vertical forms.

COMPONENTS (VIBRATOR)

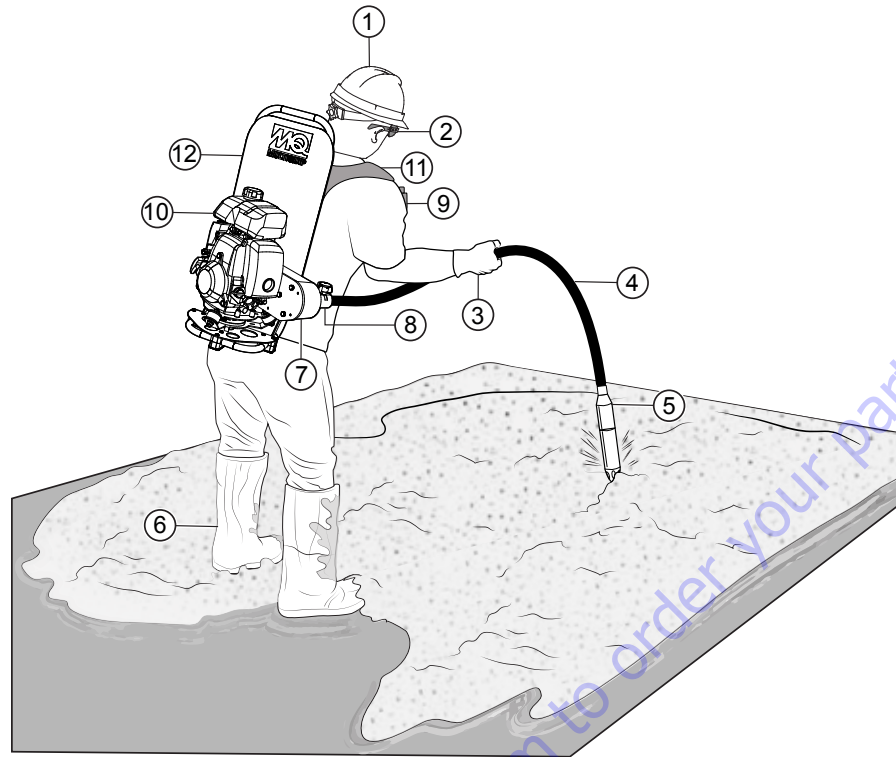

Figure 2. Vibrator Components

1. **Hard Hat** — Always wear a hard hat for head protection.
2. **Safety Glasses** — Always wear safety glasses to protect eyes from foreign matter and debris.
3. **Rubber Gloves** — Always wear rubber gloves to protect hands from abrasive materials.
4. **Flexible Shaft** — The BPX can accommodate various shaft lengths. See Table 3 and Table 4 for shaft length dimensions.
5. **Vibrating Head** — The BPX can accommodate various vibrating heads. See Table 5 for various head types. Typical applications include large retaining walls, bridge decks, and columns.
6. **Rubber Boots** — Always wear rubber boots to protect feet from abrasive materials.
7. **Belt Guard** — Prevents access to the pulleys and V-belt while the vibrator is running. **DO NOT** operate the vibrator with this cover removed.
8. **Quick Disconnect Fitting** — Allows for the quick and easy removal of the flexible shaft from the vibrator.
9. **Throttle** — Push **up** (rabbit) to increase engine speed, and pull **down** (turtle) to decrease engine speed.
10. **Engine** — The BPX utilizes a Honda GXH50 2.5-hp, 4-stroke, overhead-valve, single-cylinder gasoline engine.
11. **Backpack Harness/Pad** — The BPX is equipped with an adjustable harness. Adjust the harness to a comfortable fit so that it will not slip or fall. A back pad has been added for operator comfort.
12. **Frame** — Made of a lightweight metal alloy, this frame features an engine support platform with a swivel base that can be rotated for better operator leverage over the application. In addition, the frame has three rubber shock mounts installed to help reduce engine vibration.

COMPONENTS (ENGINE)

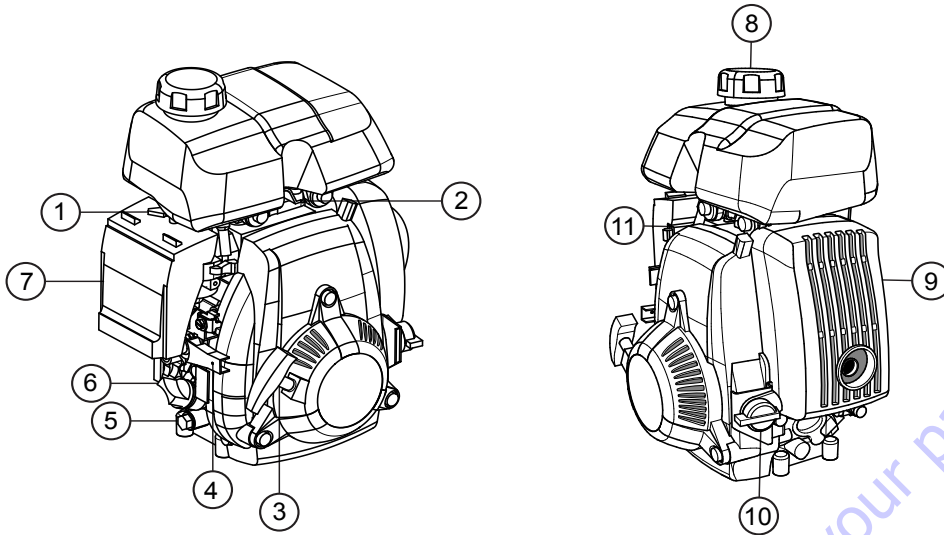

Figure 3. Honda Engine Components

1. **Choke Lever** — Used in the starting of a cold engine, or in cold weather conditions. The choke enriches the fuel mixture.
2. **Spark Plug** — Provides spark to the ignition system. Clean the spark plug once a week.
3. **Recoil Starter** — Manual starting mechanism. Slowly pull the starter grip until resistance is felt, then pull briskly and smoothly to start the engine.
4. **Throttle Lever** — Adjusts engine RPM speed.
5. **Oil Drain Plug** — Remove this plug to remove oil from the engine's crankcase.
6. **Dipstick/Oil Filler Cap** — Remove to determine if engine oil is low. Add oil through this port as recommended in Table 6.
7. **Air Cleaner** — Prevents dirt and other debris from entering the fuel system. Press the latch tabs on top of the air cleaner cover and remove the cover to gain access to the filter elements.

NOTICE

Operating the engine without an air filter, or with a damaged or worn air filter in need of replacement, will allow dirt to enter the engine, causing rapid engine wear.

8. **Fuel Tank/Fuel Filler Cap** — The fuel tank holds 0.32 gallons (1.2 liters) of unleaded gasoline. Remove the fuel filler cap to add unleaded gasoline to the fuel tank. Make sure the cap is tightened securely. **DO NOT** overfill.

DANGER

DO NOT fill the fuel tank while the engine is running or hot. In the event of a fuel spill, **DO NOT** start the engine until all fuel residue has been wiped up and the area surrounding the engine is dry. Fuel is **extremely flammable** and can ignite if it comes into contact with hot engine parts or sparks from the ignition system.



9. **Muffler** — Reduces noise and emissions. **NEVER** touch the muffler while it is hot.

WARNING

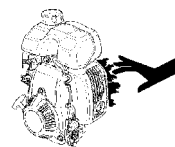

Engine components can generate extreme heat. To prevent burns, **DO NOT** touch these areas while the engine is running or immediately after operating. **NEVER** operate the engine with the muffler removed.

10. **Engine ON/OFF Switch** — **ON** position permits engine starting, **OFF** position stops the engine.
11. **Fuel Valve Lever** — Open to allow the flow of fuel, and close to prevent the flow of fuel.

ASSEMBLY AND INSTALLATION

Some components must be installed before the vibrator can be operated. This section provides general instructions on how to install those components.

Flexible Shaft and Vibrator Head Selections

Use Table 3, Table 4, and Table 5 when selecting a flexible shaft or vibrator head for your unit. Longer shaft lengths (FS Series only) can be obtained with the use of a shaft coupler (P/N 3883-501). The FSN Series flexible shafts cannot be extended.

WARNING

NEVER use vibrator heads that are not recommended by the manufacturer, as they may create a hazardous condition when using the vibrator.

NOTICE

The QD coupler and spindle shaft (not shown) are incorporated onto the FS or FSN series shafts.

Table 3. FSN Series Flexible Shafts

Model	Length ft. (m)	Weight lb. (kg)
FSN2	2 (0.6)	3 (1.3)
FSN7	7 (2.1)	6 (2.9)
FSN10	10 (3.0)	9 (4.0)
FSN12	12 (3.7)	10 (4.8)
FSN14	14 (4.3)	11 (5.1)
FSN21	21 (6.4)	18 (8.3)

Table 4. FS Series Flexible Shafts

Model	Length ft. (m)	Weight lb. (kg)
FS3	3 (0.9)	8.4 (3.8)
FS7	7 (2.1)	11 (5)
FS10	10 (3)	16 (7.2)
FS12	12 (3.7)	18 (8)
FS14	14 (4.3)	20 (9)
FS21	21 (6.4)	28 (12.7)

Table 5. Vibrator Head Selection Chart

Model	Head Type	Diameter in. (mm)	Length in. (cm)	Weight lb. (kg)	Required Shaft
900HD	Steel	$\frac{7}{8}$ (22)	14½ (37)	2.1 (1)	FSN
1000HD	Steel	1 $\frac{1}{16}$ (27)	13 $\frac{7}{8}$ (35)	2.8 (1.3)	FSN
1400HD	Steel	1 $\frac{3}{8}$ (35)	15¼ (39)	5.2 (2.4)	FS
1700HD	Steel	1 $\frac{11}{16}$ (43)	15 (38)	6.4 (2.9)	FS
2100HD	Steel	2 $\frac{1}{8}$ (54)	13¼ (34)	9.4 (4.3)	FS
2600HD	Steel	2 $\frac{5}{8}$ (67)	13¼ (34)	13.4 (6.1)	FS

CAUTION

Before initial use, disassemble the Quick Disconnect coupler at the end of the flexible shaft. Check the shaft for grease and reassemble the coupler, making sure to apply Loctite® 242™ thread sealant to the male threads of the coupler.

Failure to follow these instructions may result in **equipment damage and/or bodily injury**.

Head and Shaft Connections

NOTICE

The shafts are shipped from the factory pre-greased and require no greasing at this time. Refer to the **Maintenance** section of this manual for shaft greasing requirements.

Before operating the BPX, follow the instructions below to connect the flexible shaft, vibrator head, and vibrator.

Connecting the Flexible Shaft and Vibrator Head

NOTICE

The QD coupler and spindle shaft for the FS and FSN Series are included with the flexible shaft.

Perform the following procedure to attach the FS series or FSN series flexible shaft to the vibrator and vibrator head. Refer to Figure 4.

12. Pull up on the Quick Disconnect (Q.D.) locking knob and insert the Q.D. coupler into the eccentric end bell assembly.
13. Attach the vibrating head to the other end of the flexible shaft. The use of a small amount of pipe thread sealant (Red Loctite® 271™) is recommended on the flexible shaft casing coupling threads to prevent water from entering the vibrator head.

Applying Loctite®

When applying Red Loctite® 271™ to the flexible shaft casing threads:

1. Clean the mating connector or coupler threads with Loctite® Primer™.
2. Allow the primer to dry for several minutes before applying a ring of Red Loctite® 271™ to the middle of the flexible shaft casing threads.
3. Screw the head tightly onto the flexible shaft casing and wait one hour before use. The threads are left-handed; turn **counterclockwise** to tighten. An equivalent brand of anaerobic sealant may be used.

DISASSEMBLY

CAUTION

Wear protective leather gloves while disassembling the vibrator.

1. Remove the motor from the shaft.
2. Remove the core from the shaft housing. The head does not need to be removed unless it also requires servicing.
3. As the core is removed, slide it through a clean shop cloth to wipe off old grease. Keep it clean and off the ground or floor.
4. After inspecting the core for obvious damage, place a handful of clean grease (Shell Durina EP2 high-temperature, high-pressure grease or equivalent) in a shop cloth and slide the clean core through the grease as you feed the core back into the shaft housing. This will lightly coat the core. **DO NOT** overgrease. As the square end of the core approaches the head, turn the core slightly to engage the drive adaptor inside the head while continuing to push it towards the head.
5. Install the motor onto the shaft assembly and securely tighten the nut.
6. Test run the motor and check head vibration. **DO NOT** run the vibrator in the air (not in concrete mix) for longer than 1–2 minutes.

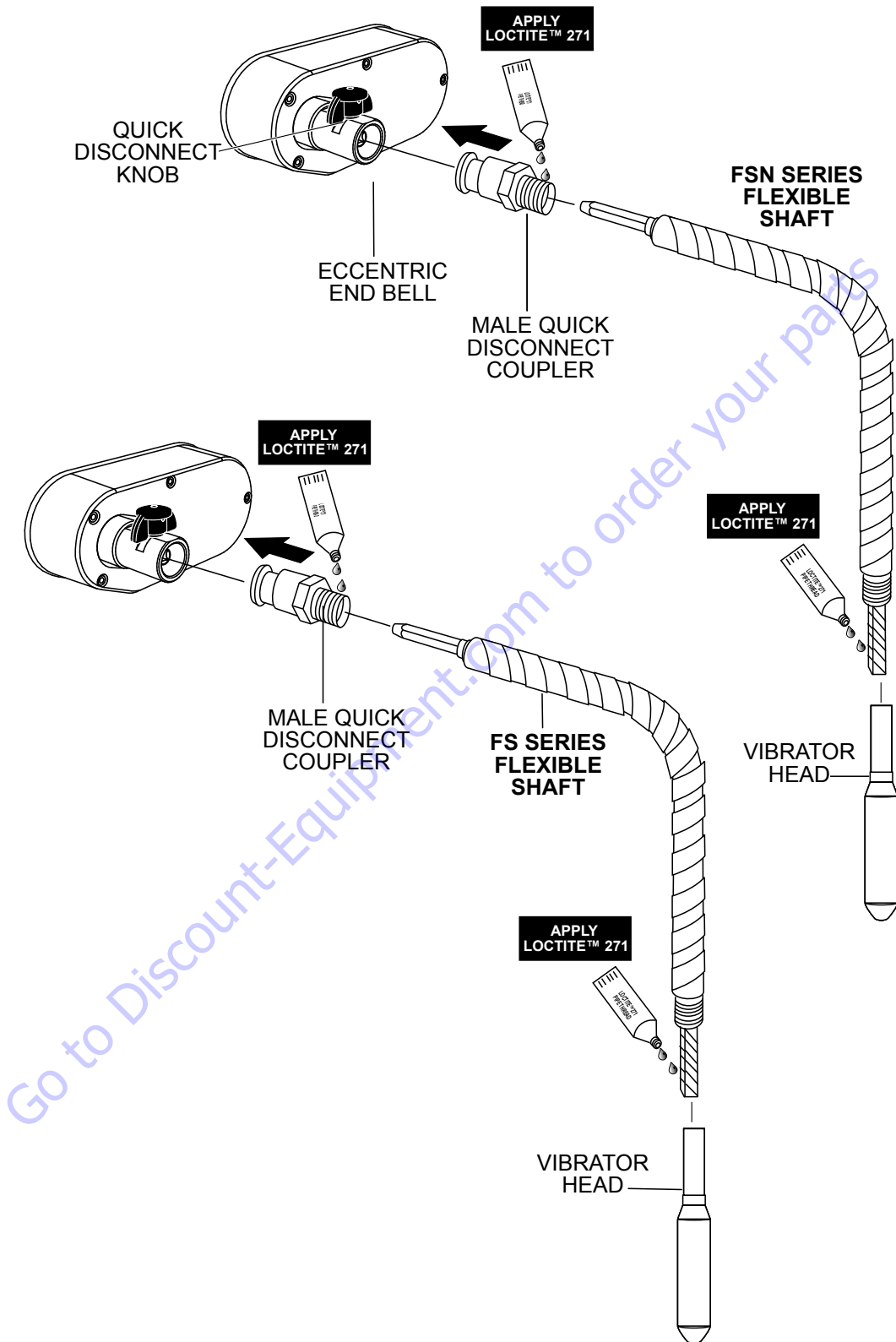

Figure 4. Flexible Head and Vibrator Head Connections

Engine Oil Check

1. To check the engine oil level, place the backpack frame on secure, level ground with the engine stopped.
2. Remove the filler dipstick from the engine oil filler hole (Figure 5) and wipe it clean.

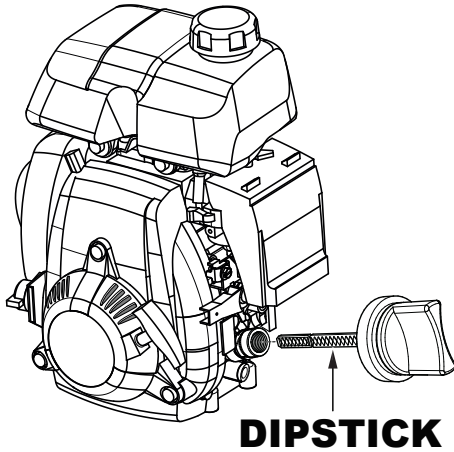

Figure 5. Engine Oil Dipstick Removal

3. Reinsert the dipstick, then remove it again without screwing it into the filler neck. Check the oil level shown on the dipstick.
4. If the oil level is low (Figure 6), fill to the edge of the oil filler hole with the recommended oil type (Table 6). Maximum oil capacity is 0.26 quarts (0.25 liters).

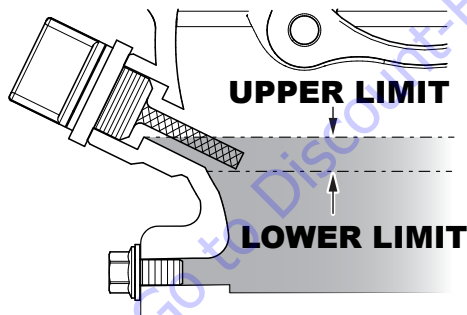

Figure 6. Engine Oil Level

Table 6. Oil Type		
Season	Temperature	Oil Type
Summer	25°C or Higher	SAE 10W-30
Spring/Fall	25°C – 10°C	SAE 10W-30/20
Winter	0°C or Lower	SAE 10W-10

Fuel Check

Remove the fuel filler cap and inspect the fuel level in the tank. If fuel is low, replenish with unleaded fuel.

DANGER



Motor fuels are **highly flammable** and can be dangerous if mishandled. **DO NOT** smoke while refueling. **NEVER** attempt to refuel while the engine is **running** or **hot!** **ALWAYS** remove the backpack before refueling.

V-Belt Check

A worn or damaged V-belt can adversely affect the performance of the vibrator.

1. Unscrew the seven bolts securing the belt guard to the unit.
2. Inspect the V-belt for defects or signs of wear.
3. If the V-belt is defective or worn, replace the V-belt as shown in the **Maintenance** section of this manual.
4. A properly tensioned V-belt (Figure 7) should deflect approximately 0.4–0.6 inches (5–10 mm) when 5 to 10 pounds of force are applied centrally between the pulleys.

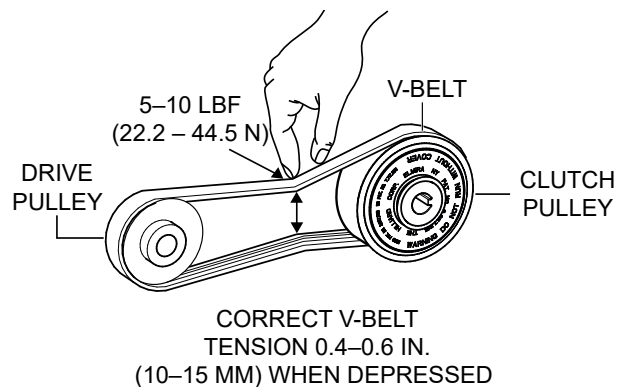

Figure 7. V-Belt Tension

BEFORE STARTING

Before starting the BPX Gasoline Vibrator, perform the following:

- Read the safety instructions at the beginning of this manual.
- Clean the engine, removing dirt and dust, particularly the engine cooling air inlet, carburetor, and air cleaner.
- Check the air filter for dirt and dust. If the air filter is dirty, replace it with a new one.
- Check the carburetor for external dirt and dust. Clean with dry compressed air.
- Check all fastening nuts and bolts for tightness.
- Check the engine oil level.
- Check the fuel level.
- Check the tension and condition of the V-belt.

INITIAL START-UP

This section is intended to assist the operator with the initial start-up of the BPX vibrator. **It is extremely important to read this section carefully before attempting to use the vibrator in the field.**

Starting the Engine

1. Move the engine fuel valve lever (Figure 8) to the **ON** position.

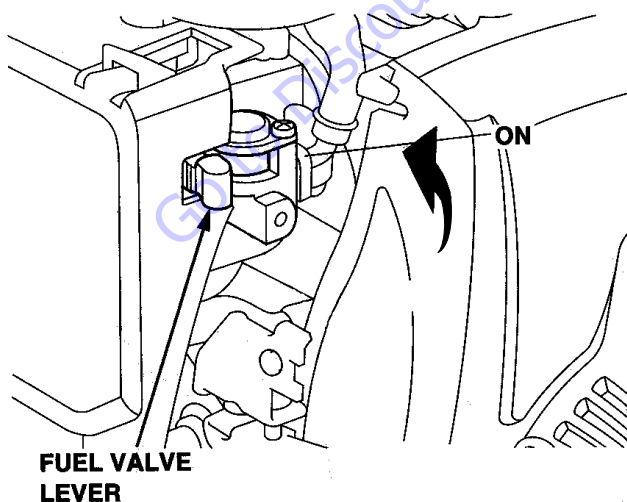

Figure 8. Engine Fuel Valve Lever (ON)

2. If starting a **cold** engine, or if the **ambient temperature is cold**, place the choke lever in the **CLOSED** position (Figure 9).

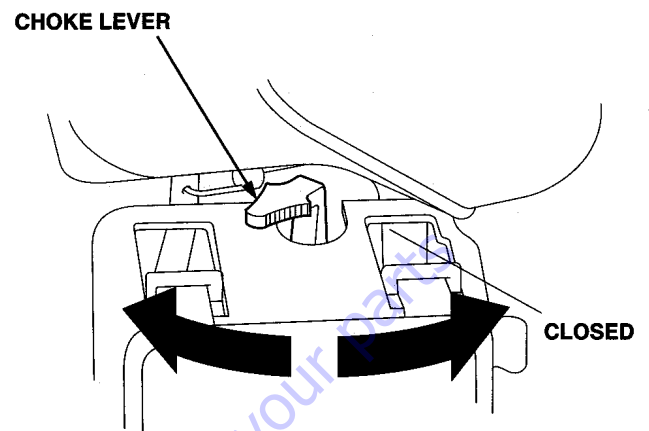

Figure 9. Engine Choke Lever (Closed)

3. If starting a **warm** engine, or if the **ambient temperature is warm**, place the choke lever in the **OPEN** position (Figure 10).

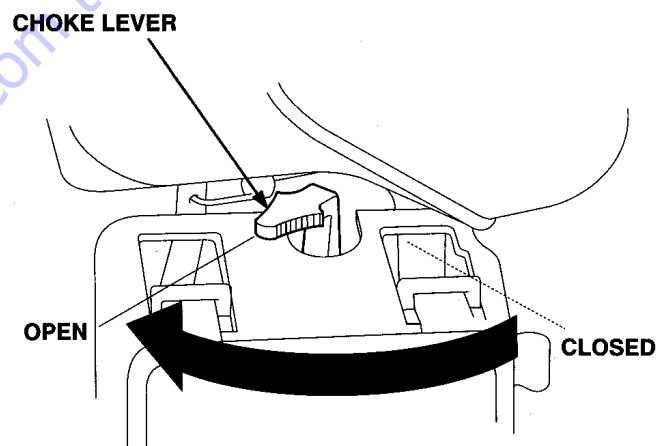

Figure 10. Engine Choke Lever (Open)

4. Place the engine ON/OFF switch in the **ON** position (Figure 11).

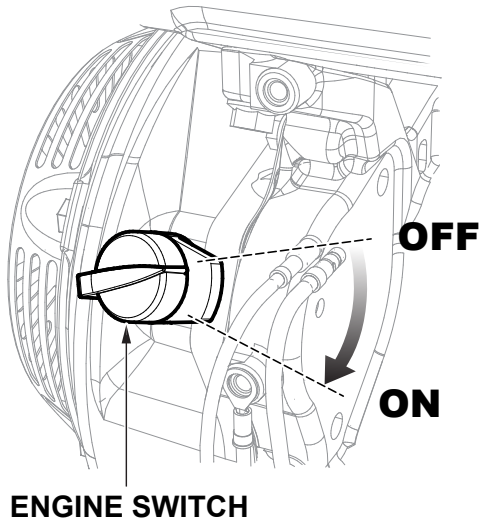

Figure 11. Engine ON/OFF Switch (ON)

5. Place the ON/OFF switch located on the left strap to the **ON** position (Figure 12).

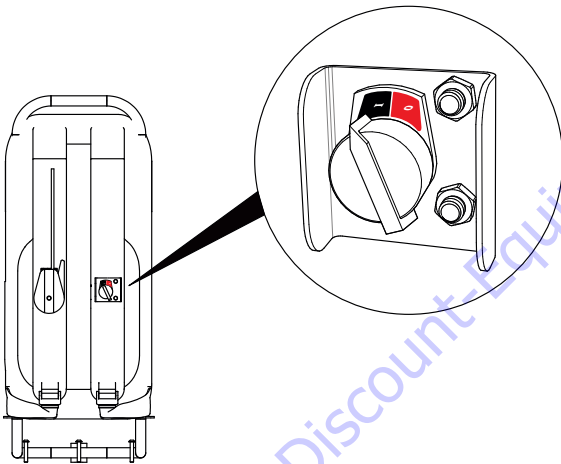

Figure 12. Engine ON/OFF Switch (ON)

6. Place the throttle lever (Figure 13) in the **UP** position (**TURTLE**) to start the engine in **IDLE** mode.

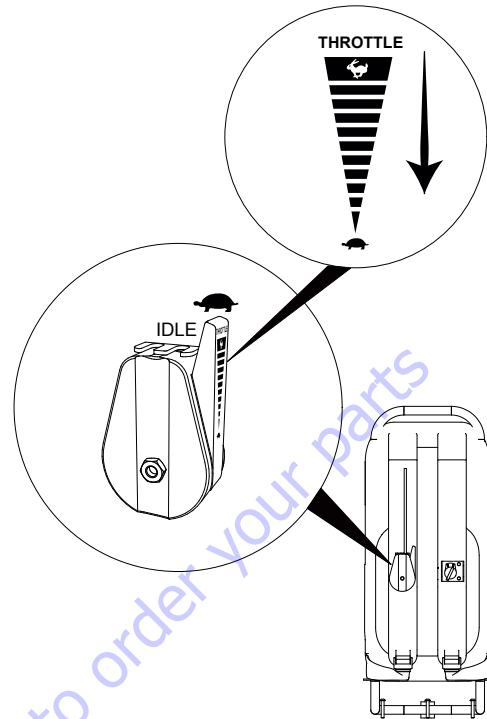

Figure 13. Throttle Lever (Idle/Turtle Position)

7. Slowly pull the starter grip (Figure 14) until resistance is felt, then pull briskly and smoothly to start the engine. Gently return the starter grip to its original position.

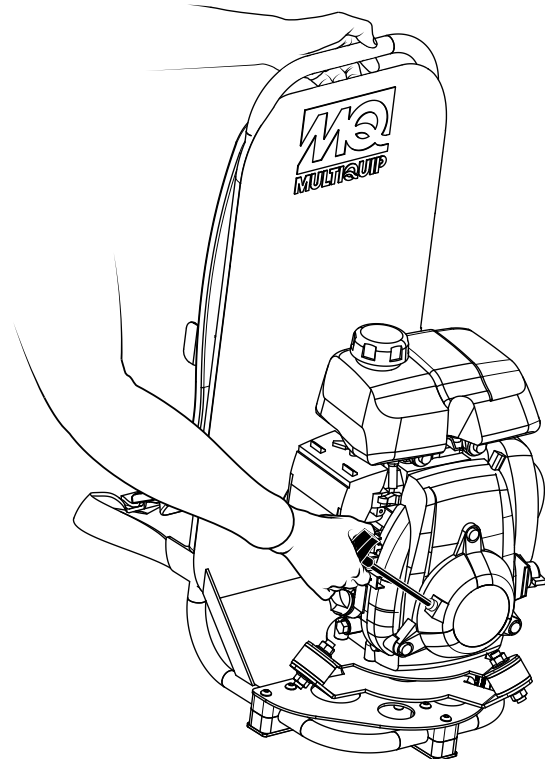

Figure 14. Starter Grip

8. If the engine has started, slowly return the choke lever to the **OPEN** position (Figure 15). If the engine has not started, repeat steps 1 through 7.

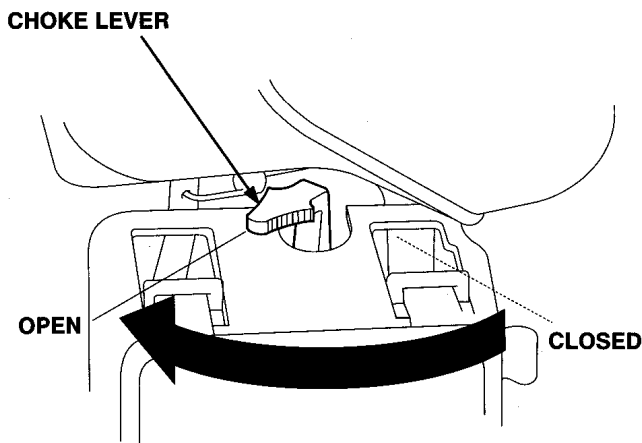

Figure 15. Choke Lever (Open)

WEARING THE BACKPACK

1. With the engine running at idle, place the backpack on an elevated, flat, level surface (e.g. a workbench or tailgate of a truck). This will enable the operator to don the backpack more easily.

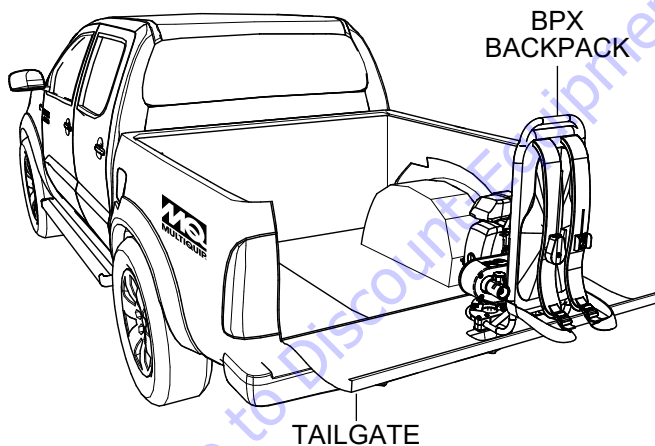

Figure 16. Backpack Placement (Truck Tailgate)

2. Place your arms through the shoulder straps and lift the backpack onto your back as shown in Figure 17.
3. Adjust the shoulder straps for comfort, then lock the shoulder strap buckle (Figure 17).

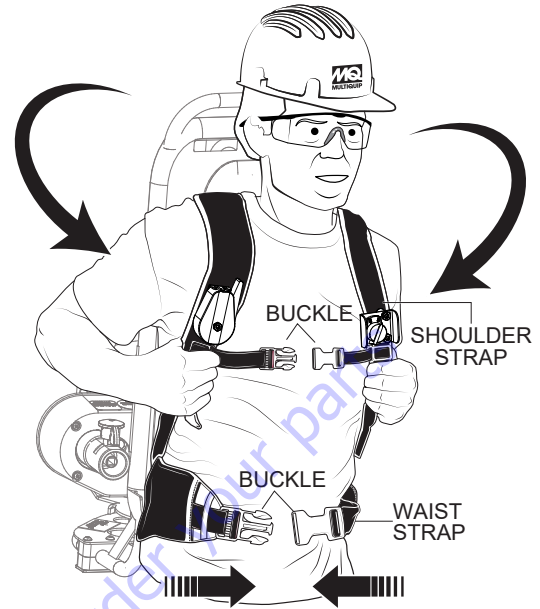

Figure 17. Backpack Adjustment

4. Adjust the waist strap for comfort, then lock the waist strap buckle.

OPERATION

WARNING

DO NOT attempt to operate the vibrator until the **Safety, General Information,** and **Inspection** sections of this manual have been **read thoroughly and understood.**



1. Insert the vibrator head into the concrete.
2. Place the throttle lever in the **DOWN** position (**RABBIT**) for normal (**FAST**) engine operation (Figure 18).

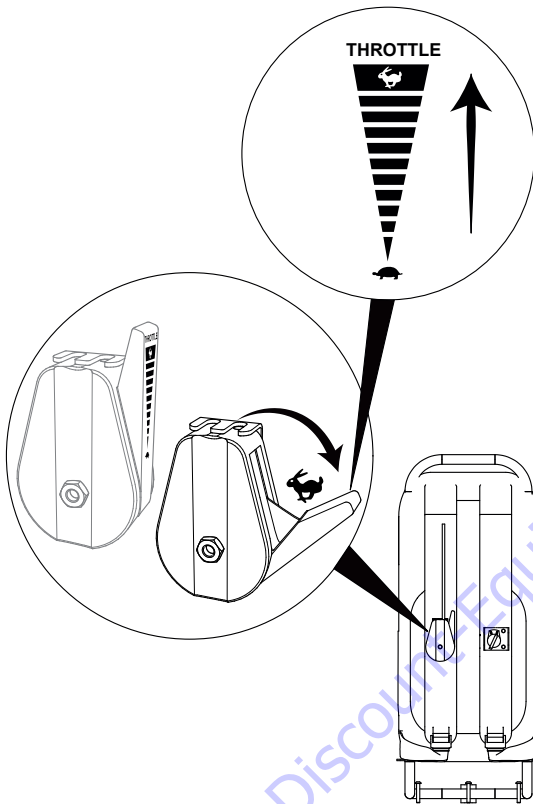

Figure 18. Throttle Lever (Fast/Rabbit Position)

3. Insert the vibrator head vertically into the concrete and move it in the pattern shown in Figure 19 to maintain a consistent area of influence.

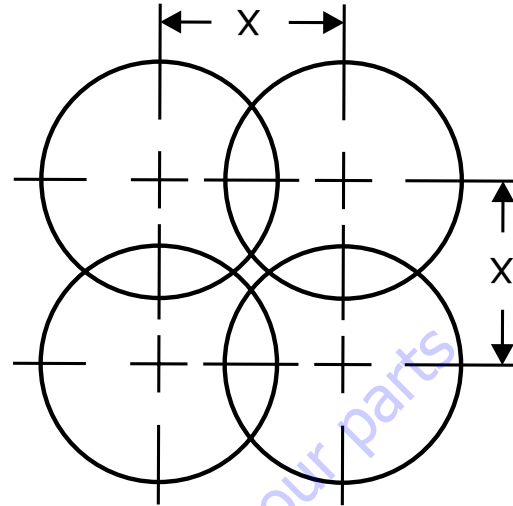

Figure 19. Area of Influence with 50% Radial Overlap

4. Immerse the head for 5 to 10 seconds, until air stops rising, then withdraw the head **slowly** to let the concrete fill the void left by the vibrator head.

NOTICE

To keep the vibrator head cool, make sure it is kept completely below the concrete surface while vibrating.

5. Keep the flexible shaft as straight as possible and **DO NOT** bend the flexible shaft sharply at any point. Sharp bends can cause overheating, necessitating early replacement of the flexible shaft.

CAUTION

If the shaft begins to helix (buckle) excessively during operation, **STOP** vibrating and investigate. This is an indication of an overload condition.

NOTICE

The vibrator head is cooled by the concrete. Operation of the vibrator head in the air (instead of concrete) for longer than two minutes will cause overheating of the bearings and premature head failure.

ENGINE SHUTDOWN

Normal Shutdown

1. Remove the flexible shaft and vibrator head from the concrete mix.
2. Place the throttle lever in the **UP** position (**TURTLE**) (Figure 20) and run the engine for three minutes at **idle** speed.

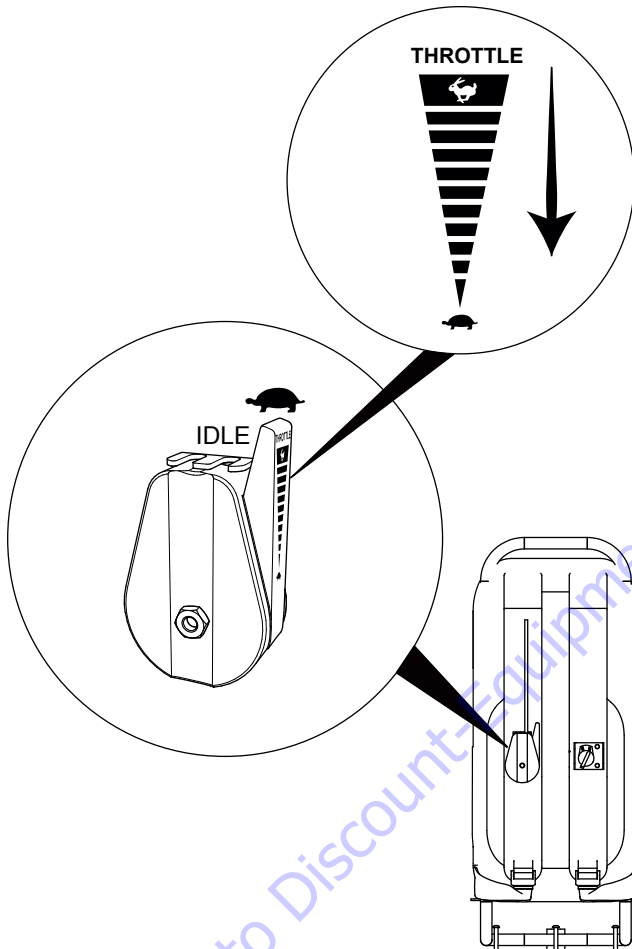

Figure 20. Throttle (Turtle/Idle Position)

3. Place the ON/OFF switch located on the **left** strap to the **OFF** position (Figure 21).

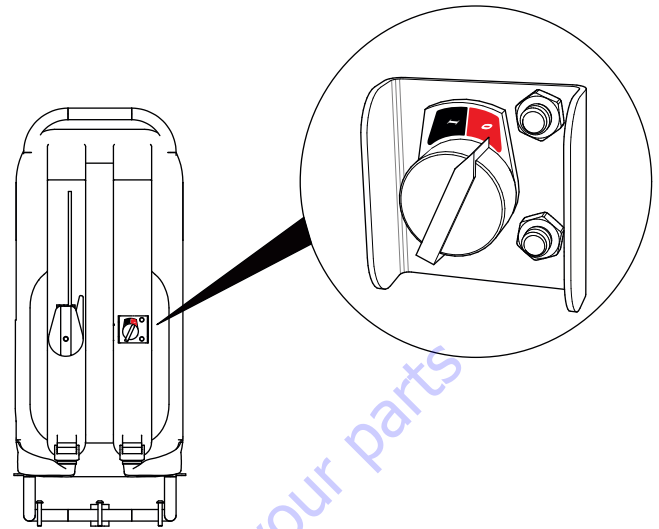

Figure 21. ON/OFF Switch (OFF)

4. Move the fuel valve lever to the **OFF** position (Figure 22).

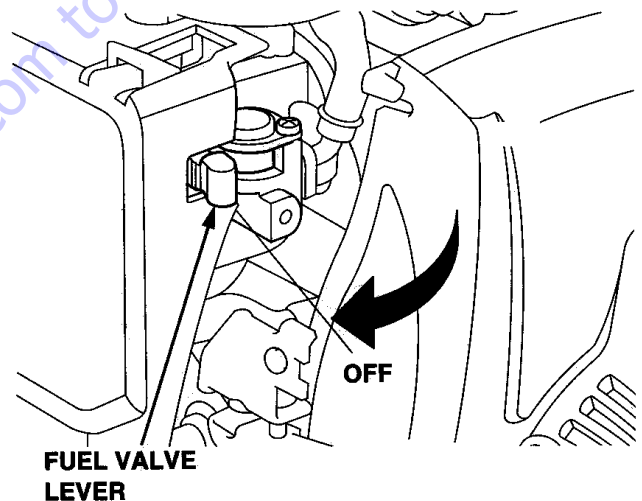

Figure 22. Fuel Valve Lever (OFF)

5. Place the engine ON/OFF switch (Figure 23) in the **OFF** position.

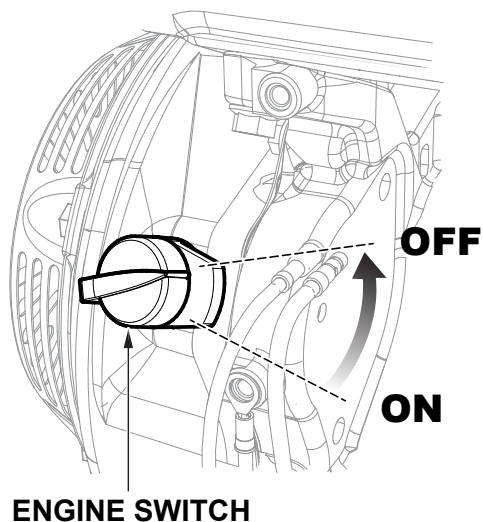

Figure 23. Engine ON/OFF Switch (OFF)

Emergency Shutdown

To quickly shut down the engine while the vibrator is in use, place the engine ON/OFF switch located on the **left** strap to the **OFF** position (Figure 21).

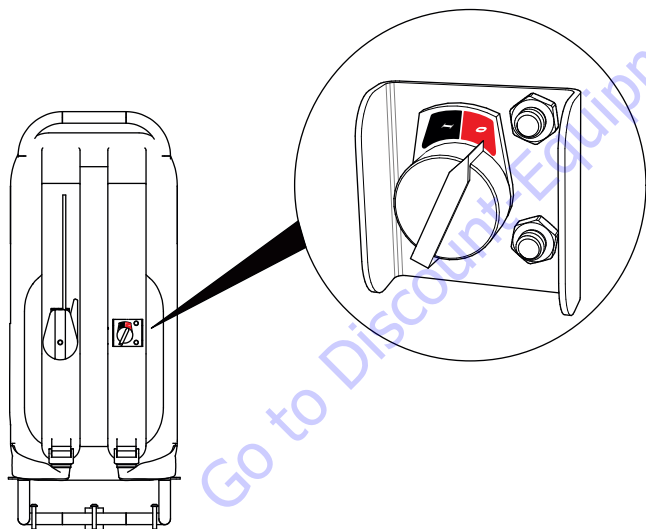

Figure 24. ON/OFF Switch (OFF)

MAINTENANCE

Use Table 7 as a general maintenance guideline when servicing your engine. For more detailed engine maintenance information, refer to the engine owner's manual supplied with your engine.

Table 7. Engine Maintenance Schedule							
Description (3)	Operation	Before	First Month or 10 Hrs.	Every 3 Months or 25 Hrs.	Every 6 Months or 50 Hrs.	Every Year or 100 Hrs.	Every 2 Years or 200 Hrs.
Engine Oil	Check	X					
	Change		X				
Air Cleaner	Check	X					
	Change			X (1)			
All Nuts and Bolts	Re-tighten if necessary	X					
Spark Plugs	Check/Clean				X		
	Replace						X
Cooling Fins	Check				X		
Spark Arrester	Clean					X	
Fuel Tank	Clean					X	
Fuel Filter	Check					X	
Idle Speed	Check/Adjust					X (2)	
Valve Clearance	Check/Adjust						X (2)
Fuel Lines	Check	Every 2 years (replace if necessary) (2)					

(1) Service more frequently when used in **dusty** areas.

(2) These items should be serviced by your service dealer, unless you have the proper tools and are mechanically proficient. Refer to the Honda shop manual for service procedures.

(3) For commercial use, log hours of operation to determine proper maintenance intervals.

To enjoy trouble-free service from your Multiquip BPX gasoline backpack vibrator, follow the maintenance procedures outlined in this manual. For additional maintenance and service information, refer to the following manuals:

- Honda Engine Owner's Manual
- MQ Flexshafts (FS and FSN Series) Manual
- MQ Vibrator Heads (900HD–2600HD) Manual

WARNING

ALWAYS stop the engine when assembling, lubricating, or adjusting any part of the vibrator. Be sure to disconnect the spark plug wire, and secure it away from the spark plug.

ENGINE MAINTENANCE

- Thoroughly remove dirt and oil from the engine and control area.
- Clean or replace the air cleaner elements as necessary.
- Check and retighten all fasteners as necessary.

Spark Plug

Remove and clean the spark plug (Figure 25), and adjust the spark plug gap to 0.024–0.028 inch (0.6–0.7 mm). This unit has electronic ignition, which requires no further adjustments.

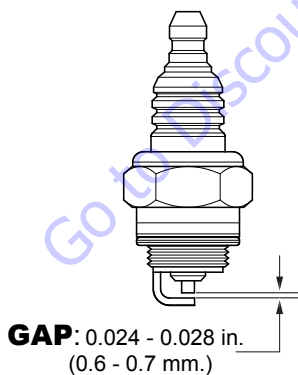

Figure 25. Spark Plug

Engine Oil

NOTICE

Dispose of used oil properly. **NEVER** pour used oil on the ground or down a drain. Used oil can usually be taken to your local recycling center or service station for reclamation. **ALWAYS** follow all environmental rules and regulations in your area concerning the disposal of hazardous waste such as used oil and oil filters.

NOTICE

ALWAYS drain the engine oil while the oil is **warm**.

Refer to Figure 26.

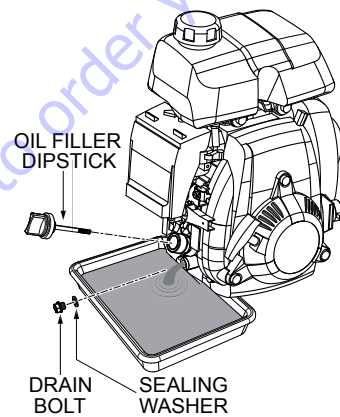

Figure 26. Draining Engine Oil

1. Remove the oil drain bolt and sealing washer and allow the oil to drain into a suitable container.
2. Replace the engine oil with the recommended oil type as listed in Table 6. For engine oil capacity, see Table 1. **DO NOT** overfill.
3. Reinstall the drain bolt with sealing washer and tighten securely.

Engine Air Cleaner

⚠ DANGER

NEVER use gasoline or low flash point solvents to clean the engine or any of its components. The possibility exists of **fire** or **explosion** which can damage the equipment and cause **severe bodily harm** or even **DEATH**.

1. Press the latch tabs on top of the air cleaner cover and remove the cover and foam filter element (Figure 27).

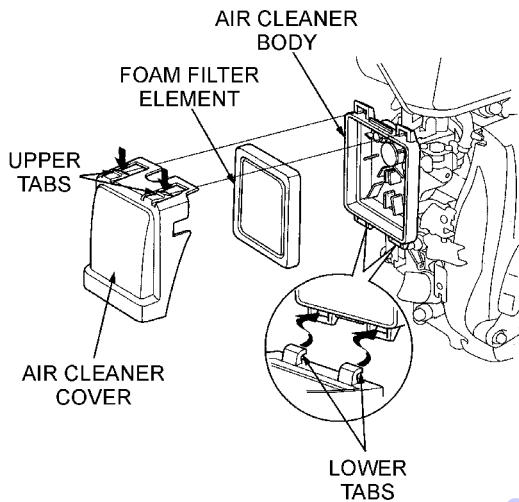

Figure 27. Engine Air Cleaner

2. Clean the foam element (Figure 28) in warm, soapy water or non-flammable solvent. Rinse and dry thoroughly.

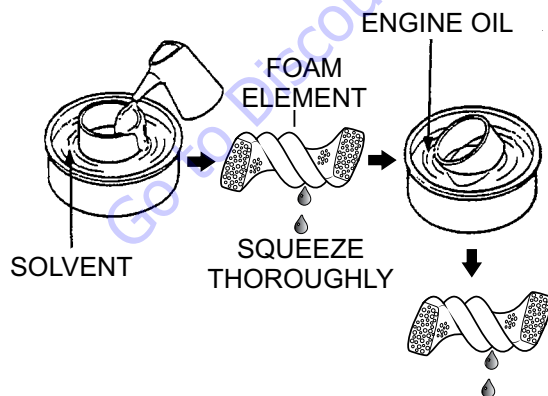

Figure 28. Foam Element

3. Dip the element in clean engine oil and completely squeeze out the excess oil from the element (Figure 28).
4. Reinstall the foam element and air cleaner cover.

V-Belt Tension

1. Remove the five screws securing the V-belt cover to the tensioning bracket.
2. The V-belt can be adjusted by loosening the bolts on the tensioning bracket (Figure 29).

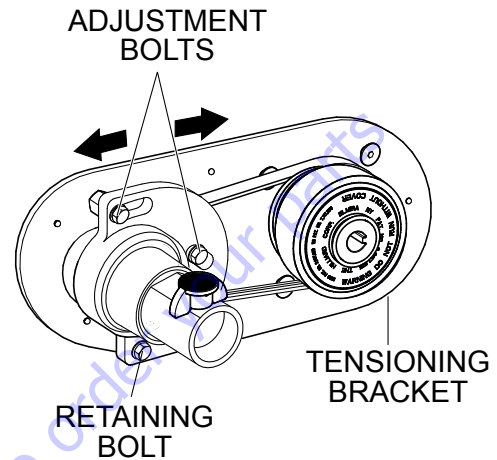

Figure 29. V-Belt Adjustment

3. When the V-belt is properly tensioned, it should deflect approximately 0.4–0.6 inches (5–10 mm) when 5 to 10 pounds of force are applied centrally between the clutch pulley and drive pulley (Figure 30).

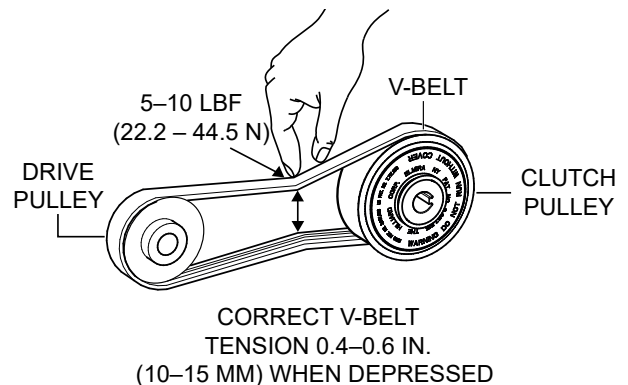

Figure 30. V-Belt Tension

4. Reinstall the V-belt cover.

VIBRATOR MAINTENANCE

Flexible Shaft Greasing Instructions

- Remove, clean, and grease the shaft core and bearings **every 50 hours**. Use **Shell Durina EP2** or equivalent grease. Wipe off old grease completely and apply new grease evenly to the shaft. Reference the flexible shaft maintenance instructions shipped with the shaft.
- **DO NOT** allow water, dust or foreign debris to enter the flexible hose while reassembling.
- If the flexible shaft becomes too hot to hold, the unit may require lubrication. Lubricate the inner core. This will reduce heat buildup.

NOTICE

When replacing the flexshaft assembly, make sure the replacement core has been lightly greased before use.

Place a handful of clean grease (Shell Durina EP2 high-temperature, high-pressure grease or equivalent) in a shop cloth and slide the clean core through the grease as you feed it back into the shaft housing.

NOTICE

After every job, or **every 50 hours**, the shaft should be disassembled, cleaned, inspected, lubricated, and reassembled.

Vibrator Head

- Vibrator heads should be inspected and lubricated every 100 hours of operation. Reference the vibrator head maintenance instructions shipped with the vibrator head.
- **ALWAYS** inspect the vibrator head for damage to the threads after every reassembly. Replace housing and head as necessary.
- Measure vibrations per minute at the vibrator head to determine if the bearings in the head require replacement.

NOTICE

Use heat to break down the Loctite® while unthreading the head from the shaft. This will prevent damage to the threads.

Quick Disconnect Lock

A small amount of lightweight oil should be used on the quick disconnect locking mechanism (Figure 31) to lubricate the locking pin and spring and prevent concrete buildup.

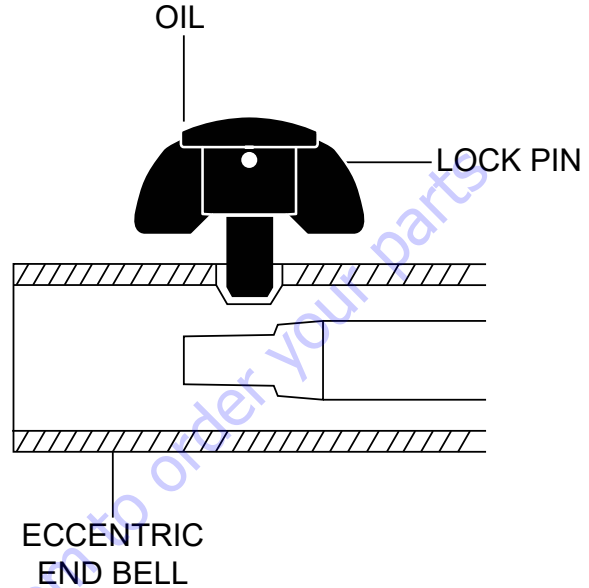

Figure 31. Quick Disconnect Lock

PREPARATION FOR LONG-TERM STORAGE

For storage of the vibrator over 30 days, the following is required:

- Drain the fuel tank completely, or add STA-BIL® to the fuel.
- Run the engine until the gasoline in the carburetor is completely consumed.
- Completely drain the oil from the crankcase and refill with fresh oil.
- Remove the spark plug, pour 2–3 cc of SAE 30 oil into the cylinder, and crank slowly to distribute the oil.
- Slowly rotate the engine a few times with the starter rope and install a new plug.
- Pull out the starter rope slowly and stop at the compression point.
- Clean all external parts of the engine and frame with a soft cloth.
- Cover the unit and store in a clean, dry place.

TROUBLESHOOTING

Troubleshooting (Engine)		
Symptom	Possible Problem	Solution
Difficult to start, fuel is available, but no spark at spark plug.	Spark plug bridging?	Check gap, insulation or replace spark plug.
	Carbon deposit on spark plug?	Clean or replace spark plug.
	Short circuit due to deficient spark plug insulation?	Check spark plug insulation, replace if worn.
	Improper spark plug gap?	Set to proper gap.
	Spark plug is red?	Check transistor ignition unit.
	Spark plug is bluish white?	If insufficient compression, repair or replace engine. If injected air leaking, correct leak. If carburetor jets clogged, clean carburetor.
	No spark present at tip of spark plug?	Check if transistor ignition unit is broken, and replace defective unit. Check if voltage cord cracked or broken and replace. Check if spark plug is fouled and replace.
	No oil?	Add oil as required.
	Oil pressure alarm lamp blinks upon starting? (if applicable)	Check automatic shutdown circuit, oil sensor. (if applicable)
Difficult to start, fuel is available, and spark is present at the spark plug.	ON/OFF switch is shorted?	Check switch wiring, replace switch.
	Ignition coil defective?	Replace ignition coil.
	Improper spark gap, points dirty?	Set correct spark gap and clean points.
	Condenser insulation worn or short circuiting?	Replace condenser.
	Spark plug wire broken or short circuiting?	Replace defective spark plug wiring.
Difficult to start, fuel is available, spark is present and compression is normal.	Wrong fuel type?	Flush fuel system, replace with correct type of fuel.
	Water or dust in fuel system?	Flush fuel system.
	Air cleaner dirty?	Clean or replace air cleaner.
	Choke open?	Close choke.
Difficult to start, fuel is available, spark is present and compression is low.	Suction/exhaust valve stuck or protruded?	Reseat valves.
	Piston ring and/or cylinder worn?	Replace piston rings and/or piston.
	Cylinder head and/or spark plug not tightened properly?	Torque cylinder head bolts and spark plug.
No fuel present at carburetor.	Head gasket and/or spark plug gasket damaged?	Replace head and spark plug gaskets.
	No fuel in fuel tank?	Fill with correct type of fuel.
	Fuel cock does not open properly?	Apply lubricant to loosen fuel cock lever, replace if necessary.
	Fuel filter/lines clogged?	Replace fuel filter.
	Fuel tank cap breather hole clogged?	Clean or replace fuel tank cap.
Air in fuel line?	Bleed fuel line.	

EXPLANATION OF CODE IN REMARKS COLUMN

The following section explains the different symbols and remarks used in the Parts section of this manual. Use the help numbers found on the back page of the manual if there are any questions.

NOTICE

The contents and part numbers listed in the parts section are subject to change **without notice**. Multiquip does not guarantee the availability of the parts listed.

SAMPLE PARTS LIST

NO.	PART NO.	PART NAME	QTY.	REMARKS
1	12345	BOLT	1	INCLUDES ITEMS W/%
2%		WASHER, 1/4 IN.		NOT SOLD SEPARATELY
2%	12347	WASHER, 3/8 IN. ...	1	MQ-45T ONLY
3	12348	HOSE	A/R	MAKE LOCALLY
4	12349	BEARING	1	S/N 2345B AND ABOVE

NO. Column

Unique Symbols — All items with same unique symbol (@, #, +, %, or >) in the number column belong to the same assembly or kit, which is indicated by a note in the “Remarks” column.

Duplicate Item Numbers — Duplicate numbers indicate multiple part numbers, which are in effect for the same general item, such as different size saw blade guards in use or a part that has been updated on newer versions of the same machine.

NOTICE

When ordering a part that has more than one item number listed, check the remarks column for help in determining the proper part to order.

PART NO. Column

Numbers Used — Part numbers can be indicated by a number, a blank entry, or TBD.

TBD (To Be Determined) is generally used to show a part that has not been assigned a formal part number at the time of publication.

A blank entry generally indicates that the item is not sold separately or is not sold by Multiquip. Other entries will be clarified in the “Remarks” Column.

QTY. Column

Numbers Used — Item quantity can be indicated by a number, a blank entry, or A/R.

A/R (As Required) is generally used for hoses or other parts that are sold in bulk and cut to length.

A blank entry generally indicates that the item is not sold separately. Other entries will be clarified in the “Remarks” Column.

REMARKS Column

Some of the most common notes found in the “Remarks” Column are listed below. Other additional notes needed to describe the item can also be shown.

Assembly/Kit — All items on the parts list with the same unique symbol will be included when this item is purchased.

Indicated by:

“INCLUDES ITEMS W/(unique symbol)”

Serial Number Break — Used to list an effective serial number range where a particular part is used.

Indicated by:

“S/N XXXXX AND BELOW”

“S/N XXXX AND ABOVE”

“S/N XXXX TO S/N XXX”

Specific Model Number Use — Indicates that the part is used only with the specific model number or model number variant listed. It can also be used to show a part is NOT used on a specific model or model number variant.

Indicated by:

“XXXXX ONLY”

“NOT USED ON XXXX”

“Make/Obtain Locally” — Indicates that the part can be purchased at any hardware shop or made out of available items. Examples include battery cables, shims, and certain washers and nuts.

“Not Sold Separately” — Indicates that an item cannot be purchased as a separate item and is either part of an assembly/kit that can be purchased, or is not available for sale through Multiquip.

SUGGESTED SPARE PARTS

BPX GASOLINE BACKPACK VIBRATOR WITH HONDA GXH50UQXA ENGINE

1 to 3 units

Qty.	P/N	Description
2.....	17211ZM7000	ELEMENT, AIR
3.....	9805655777.....	SPARK PLUG (NKG)
3.....	28462ZM70003	ROPE, STARTER
1.....	17620ZL8023	CAP, FUEL
3.....	14482.....	BELT, BACKPACK
1.....	28461ZM3003	KNOB, RECOIL STARTER
1.....	34150ZH7023.....	OIL ALERT UNIT
1.....	35480ZM7801	OIL LEVEL SWITCH

NOTICE

Part numbers on this Suggested Spare Parts list may supersede/replace the part numbers shown in the following parts lists.

NAMEPLATE AND DECALS ASSY.

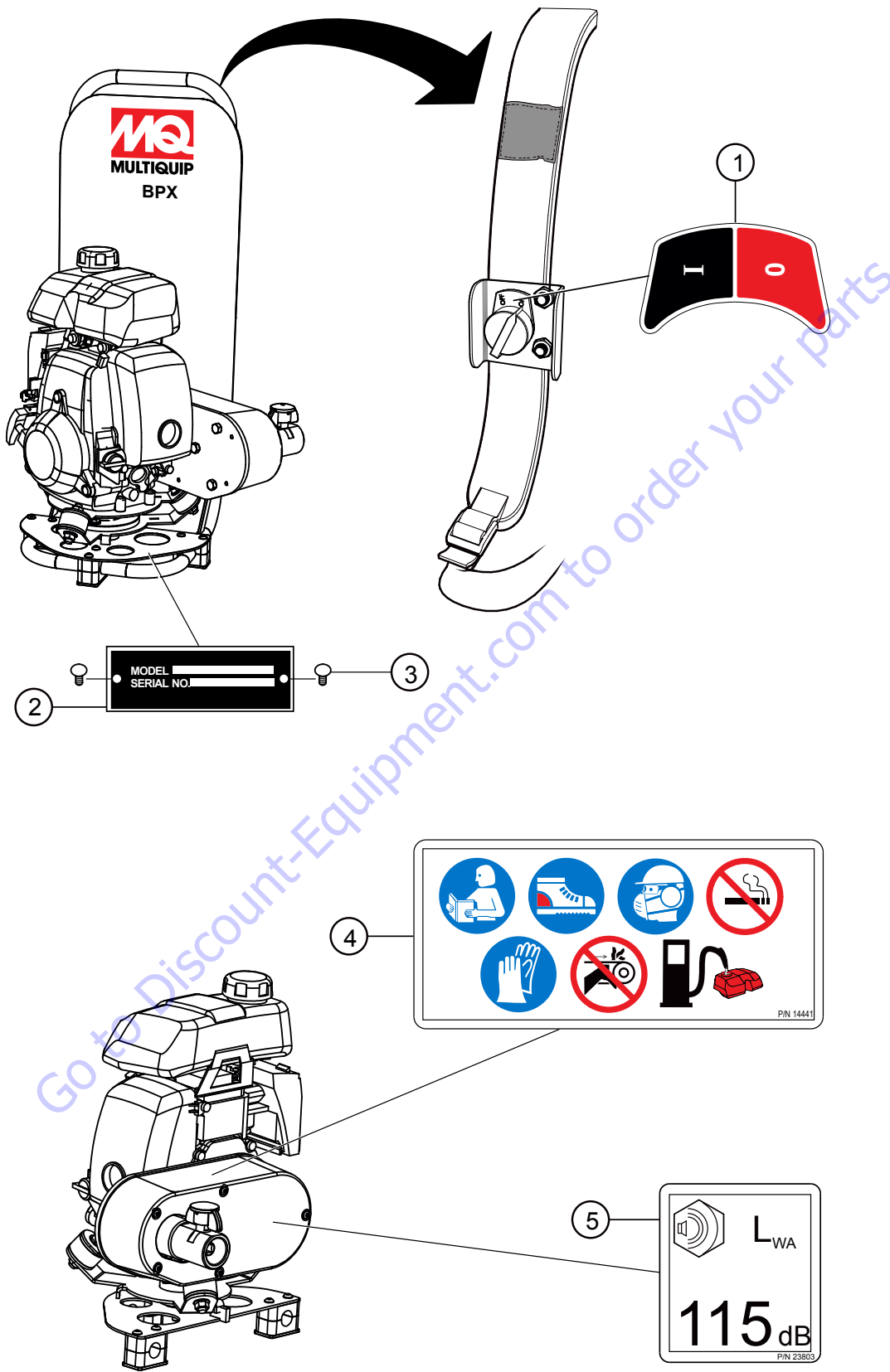

NAMEPLATE AND DECALS ASSY.

<u>NO.</u>	<u>PART NO.</u>	<u>PART NAME</u>	<u>QTY.</u>	<u>REMARKS</u>
1	14437	DECAL, ON/OFF SWITCH, BPX, .48" X .85"	1	
2		SERIAL PLATE, NON CE	1	CONTACTMQPARTS
3	4014	SCREW, 2-3/16" P-K	2	
4	14441	DECAL, READ, PROTECTION, SMOKING, GUARD, GAS	1	
5	23803	DECAL, GUARANTEED SOUND, 115 DB	1	

Go to Discount-Equipment.com to order your parts

VIBRATOR ASSY.

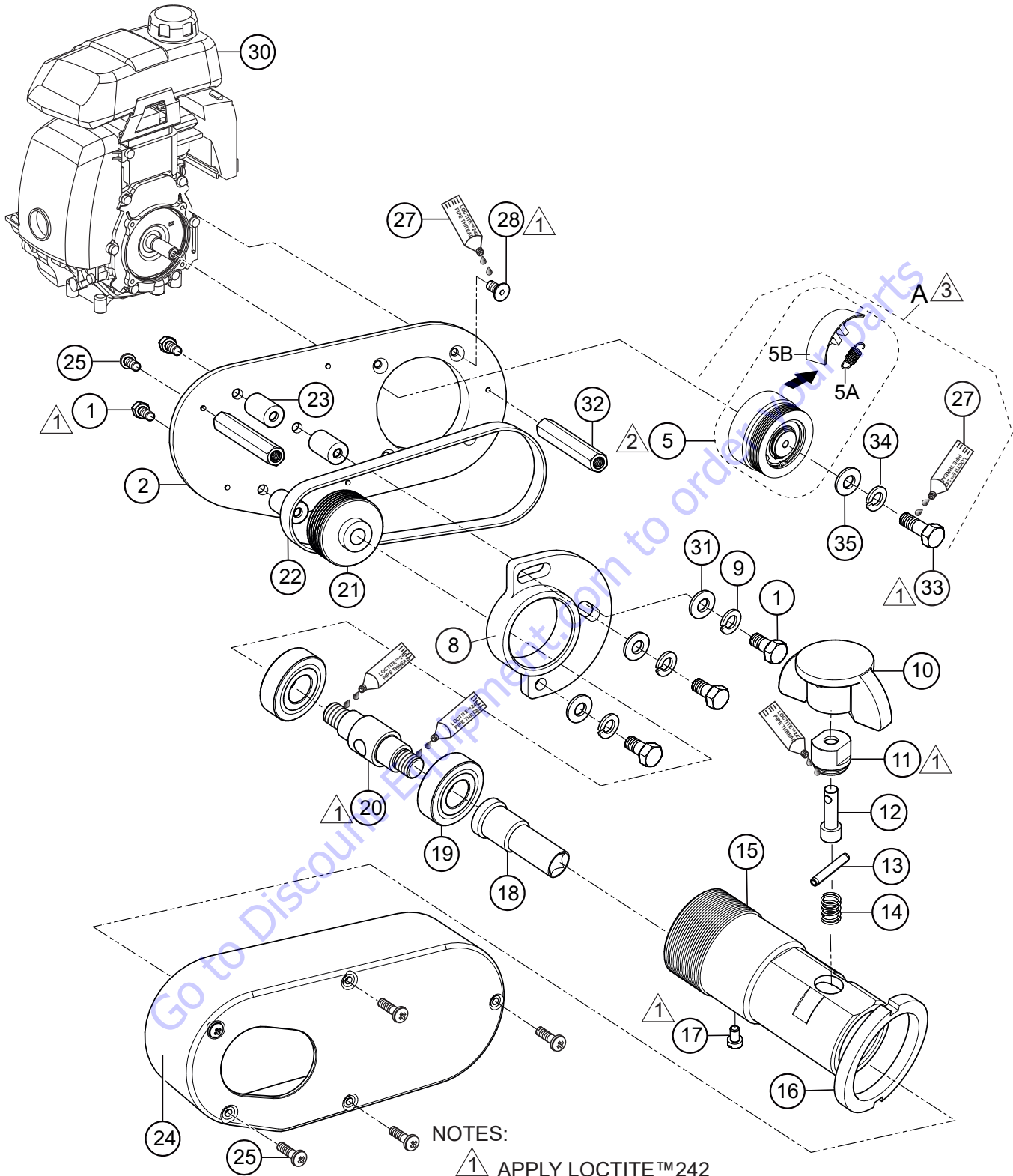

NOTES:

- ▲ 1 APPLY LOCTITE™ 242
- ▲ 2 NORAM CLUTCH REPLACES HILLIARD AND OZTEC CLUTCHES. ORDER SERVICE KIT 14530-SK FOR REPLACEMENT.
- ▲ 3 ALSO INCLUDES ITEMS 1, 2, 9, 23, 24, 25, 27, 31 AND 32.

VIBRATOR ASSY.

<u>NO.</u>	<u>PART NO.</u>	<u>PART NAME</u>	<u>QTY.</u>	<u>REMARKS</u>
A	14530-SK	SERVICE KIT, VIBRATORY CLUTCH.....	6.....	INCLUDES ITEMS W/#
1#	0655	SCREW, HHC 5/16"-18 X 5/8"	6	
2#	14470	PLATE, CLUTCH MOUNTING	1	
5	14487	CLUTCH, CENTRIFUGAL, HILLIARD.....	1.....	S/N NB4801019~ND4801095 NLA, REPLACE W/ITEM A
5	ZT363A1	CLUTCH ASSY., 5/8" CENTRIF OZTEC	1.....	S/N NH4801107~NK4801191 NLA, REPLACE W/ITEM A
5#	14530	CLUTCH, CENTRIF 1.58MM BORE, NORAM ..	1.....	S/N MF4801223 AND ABOVE INCLUDES ITEMS W/%
5A%	14530-01	CLUTCH SPRING	1	
5B%	14530-02	CLUTCH SHOE	1	
8	14472	BRACKET, TENSIONING	1	
9#	0161 C	WASHER, LOCK 5/16" MED.	3	
10	50125-04	KNOB, PLASTIC QUICK DISCONNECT	1	
11	90004-07	HOUSING, SPRING	1	
12	7200-001	LOCK PIN, QUICK DISCONNECT	1	
13	07502-016	PIN, SLOTTED SPRING 5/32" X 1.00"	1	
14	59999-08	RETAINER SPRING, BACKPACK	1	
15	14473	COUPLING HOUSING	1	
16	14475	NUT, SPANNER, LOCKING, 2-20 X .25	1	
17	14469	SCREW, FHCSL 10-32 X .313, SS	1	
18	14478	COUPLING SHAFT, PULLEY	1	
19	14480	BEARING, BACKPACK SHAFT	2	
20	14477	SHAFT, CENTER PULLEY	1	
21	14479	PULLEY, BACKPACK DRIVEN	1	
22	14482	BELT, BACKPACK	1	
23#	14504	STANDOFF 5/16-18 X 1, 45 LG.	3	
24#	14462	GUARD, BELT BACKPACK	1	
25#	5065 B	SCREW, PHP 10-32 X 1/2"	10	
27#	1477	LOCTITE™242, BLUE, .5CC BOTTLE	1	
28	14489	SCREW, FHSC 1/4"-28 X 5/8"	4	
30	14432	ENGINE, HONDA GXH50UQXA	1	
31#	0300 B	WASHER, FLAT SAE 5/16"	3	
32#	14445	STAND OFF, 10-32 X 2.50 LG	5	
33#	06509-008	SCREW, HHC 1/4-28 X 1	1	
34#	0181 B	WASHER, LOCK 1/4" MED	1	
35#	0948	WASHER, FLAT SAE 1/4"	1	

FRAME AND SWIVEL ASSY.

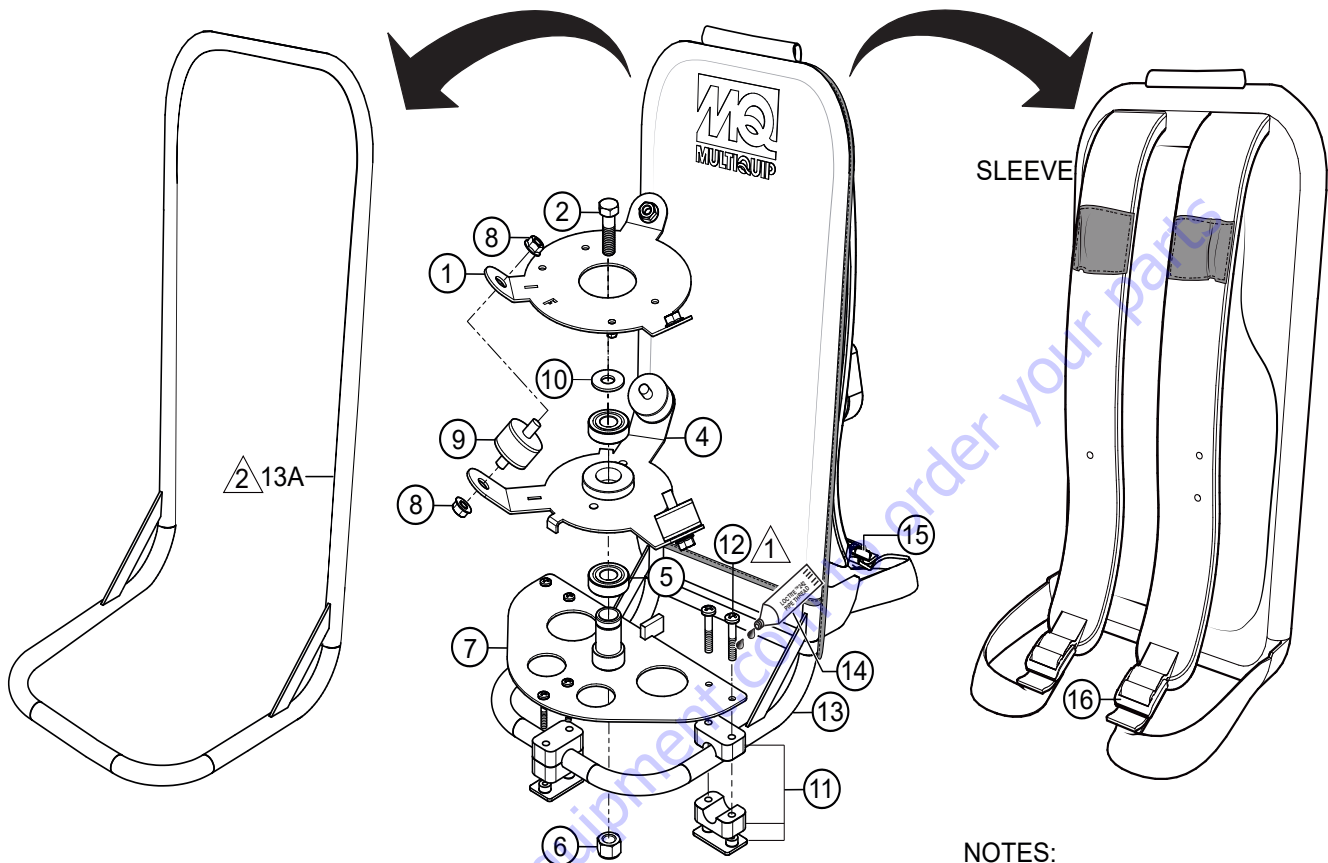

NOTES:

- ① APPLY LOCTITE™242.
- ② INCLUDED WITH ITEM 13.

FRAME AND SWIVEL ASSY.

<u>NO.</u>	<u>PART NO.</u>	<u>PART NAME</u>	<u>QTY.</u>	<u>REMARKS</u>
1	14439	PLATE, SWIVEL TOP	1	
2	8156	SCREW, HHC 3/8"-16 X 2-1/2"	1	
4	14438	PLATE, SWIVEL BASE	1	
5	14480	BEARING, BACKPACK SHAFT	2	
6	10133	NUT, NYLOC 3/8"-16	1	
7	14450	SWIVEL MOUNT W/A	1	
8	46272	NUT, FLANGED 3/8"-16	6	
9	14442	DAMPENER, VIBRATION	3	
10	4001	WASHER, FLAT USS 3/8" PLD.	1	
11	14443	CLAMP, FRAME 3/4"	3	
12	14467	SCREW, BHC 1/4"-20 X 1-1/2"	6	
13	14431	TUBE FRAME W/SLEEVE	1	INCLUDES ITEMS W/ SLEEVE CANNOT BE SOLD SEPARATELY
13A#	14431-01	TUBE FRAME W/O SLEEVE	1	
14	1477	LOCTITE™242, BLUE, .5CC BOTTLE	1	
15#	14498	BUCKLE, WAIST STRAP	1	
16#	14499	BUCKLE, CHEST STRAP	1	

ENGINE MOUNTING ASSY.

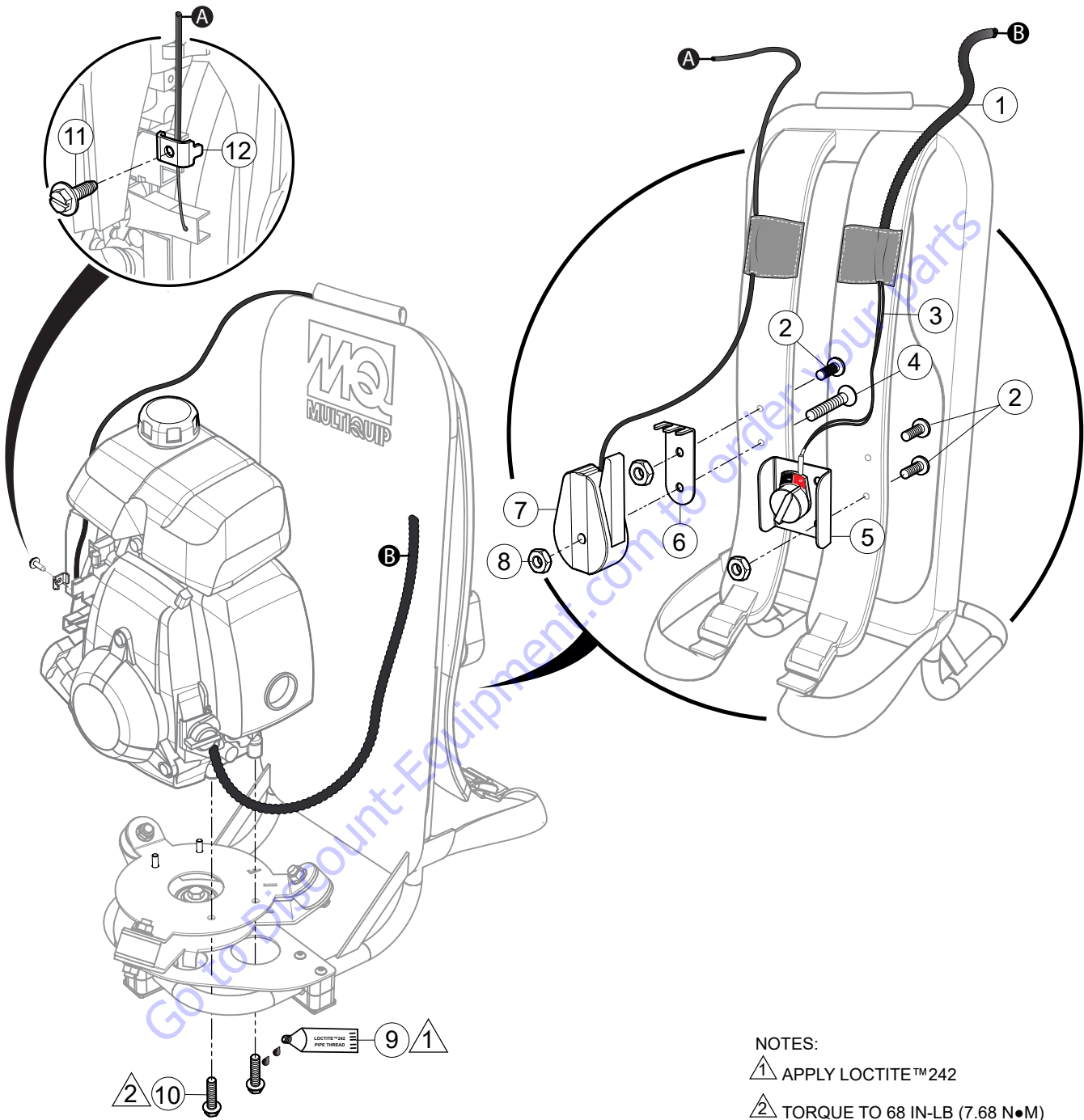

NOTES:

- ① APPLY LOCTITE™ 242
- ② TORQUE TO 68 IN-LB (7.68 N•M)

ENGINE MOUNTING ASSY.

<u>NO.</u>	<u>PART NO.</u>	<u>PART NAME</u>	<u>QTY.</u>	<u>REMARKS</u>
1	60221	SPLIT LOOM, DIA.375, 4 FT.....	1.....	1PC = 1FT.
2	14489	SCREW, FHSC, 1/4"-28 X 5/8"	3	
3	14485	HARNESS, WIRING	1	
4	14495	SCREW, FHSC, 1/4"-28 X 1-1/2"	1	
5	14433	MOUNT, SWITCH, ON-OFF	1	
6	14440	BRACKET, THROTTLE MOUNT	1	
7	14434	THROTTLE, LEVER/CABLE PLASTIC	1	
8	19378	NUT, HEX JAM 1/4"-28	4	
9	1477	LOCTITE™242, BLUE, .5CC BOTTLE	1	
10	42542	SCREW HFS, ZP, M6-1.0 X 16	4	
11	34308	SCREW, HHF SLOT, #10-32 X 5/8"	1	
12	16576891000	HOLDER, CABLE	1	

Go to Discount-Equipment.com to order your parts

ENGINE SERVICE PARTS ASSY.

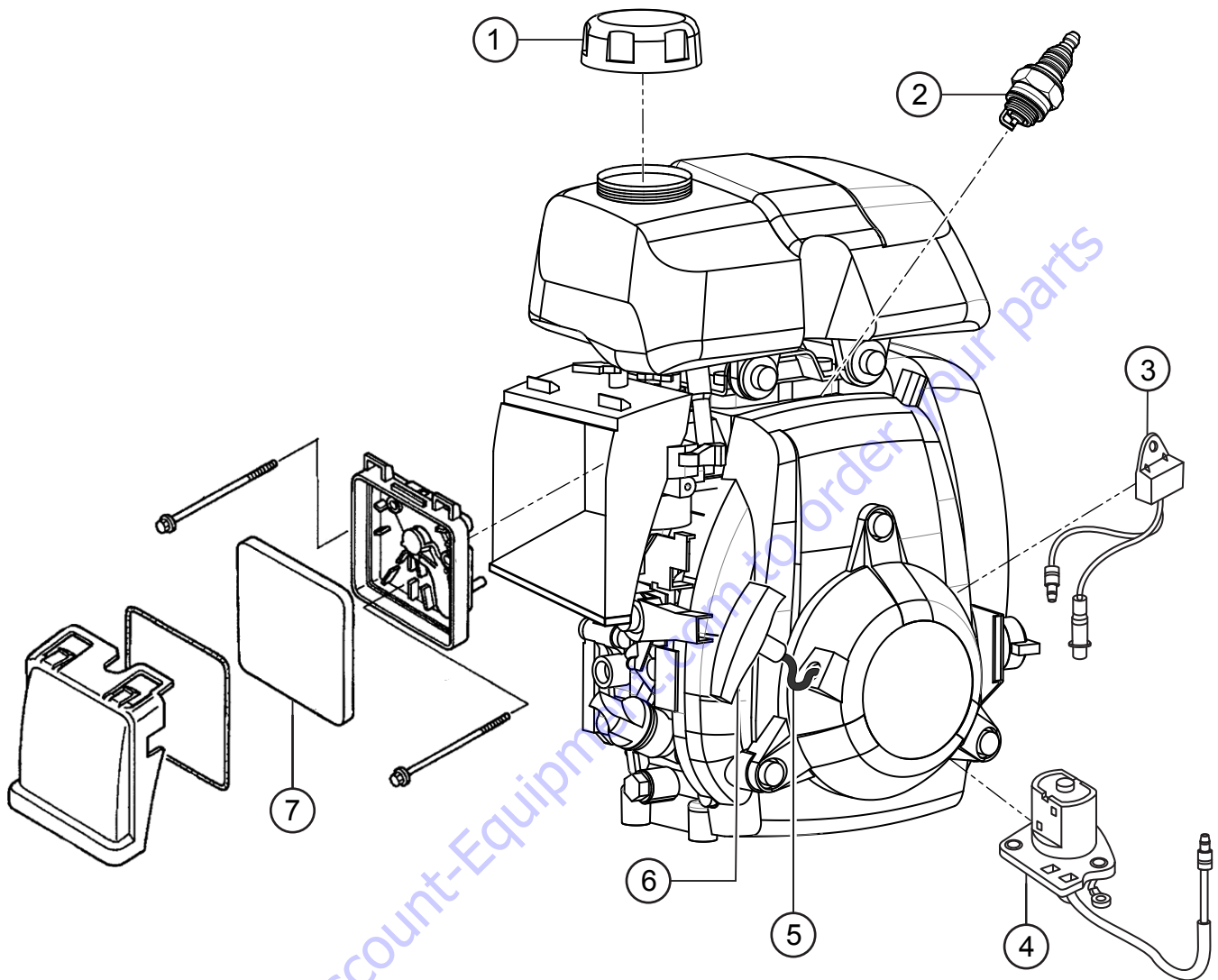

ENGINE SERVICE PARTS ASSY.

<u>NO.</u>	<u>PART NO.</u>	<u>PART NAME</u>	<u>QTY.</u>	<u>REMARKS</u>
1	17620ZL8023	CAP, FUEL	1	
2	9805655777	SPARK PLUG (NKG)	1	
3	34150ZH7023	OIL ALERT UNIT	1	
4	35480ZM7801	OIL LEVEL SWITCH ASSY.	1	
5	28462ZM70003	ROPE, STARTER	1	
6	28461ZM3003	KNOB, RECOIL STARTER	1	
7	17211ZM7000	ELEMENT, AIR	1	

Go to Discount-Equipment.com to order your parts

PARTS FINDER

**Search Website
by Part Number**



**Search Manual
Library For Parts
Manual & Lookup Part
Numbers – Purchase
or Request Quote**

Search Manuals

Enter your information to search for manuals and parts.

* Brand:

* Model:

* Serial:

* Part Number:

SEARCH

**Can't Find Part or
Manual? Request Help
by Manufacturer,
Model & Description**

Parts Order Form

Please fill in the following information:

Manufacturer:

Model:

Description:

Quantity:

Part Number:

Part Name:

Part Description:

Part Location:

Part Condition:

Part Status:

Part Price:

Part Weight:

Part Dimensions:

Part Material:

Part Color:

Part Finish:

Part Notes:

Part Images:

Part Attachments:

Part Specifications:

Part Certifications:

Part Compliance:

Part Safety:

Part Environmental:

Part Other:

Submit

Discount-Equipment.com is your online resource for quality parts & equipment.

Florida: **561-964-4949** Outside Florida TOLL FREE: **877-690-3101**

Need parts?

Click on this link: <http://www.discount-equipment.com/category/5443-parts/> and choose one of the options to help get the right parts and equipment you are looking for. Please have the machine model and serial number available in order to help us get you the correct parts. If you don't find the part on the website or on once of the online manuals, please fill out the request form and one of our experienced staff members will get back to you with a quote for the right part that your machine needs.

We sell worldwide for the brands: Genie, Terex, JLG, MultiQuip, Mikasa, Essick, Whiteman, Mayco, Toro Stone, Diamond Products, Generac Magnum, Airman, Haulotte, Barreto, Power Blanket, Nifty Lift, Atlas Copco, Chicago Pneumatic, Allmand, Miller Curber, Skyjack, Lull, Skytrak, Tsurumi, Husquvarna Target, , Stow, Wacker, Sakai, Mi-T- M, Sullair, Basic, Dynapac, MBW, Weber, Bartell, Bennar Newman, Haulotte, Ditch Runner, Menegotti, Morrison, Contec, Buddy, Crown, Edco, Wyco, Bomag, Laymor, Barreto, EZ Trench, Bil-Jax, F.S. Curtis, Gehl Pavers, Heli, Honda, ICS/PowerGrit, IHI, Partner, Imer, Clipper, MMD, Koshin, Rice, CH&E, General Equipment, ,AMida, Coleman, NAC, Gradall, Square Shooter, Kent, Stanley, Tamco, Toku, Hatz, Kohler, Robin, Wisconsin, Northrock, Oztec, Toker TK, Rol-Air, Small Line, Wanco, Yanmar

OPERATION AND PARTS MANUAL

HERE'S HOW TO GET HELP

PLEASE HAVE THE MODEL AND SERIAL
NUMBER ON-HAND WHEN CALLING

Go to Discount-Equipment.com to order your parts

Your Local Dealer is:



www.Discount-Equipment.com



PN: 14454