



STARTING SERIAL
160910316

PARTS LIST MANUAL

Magna-Trap™ 9" Turbo-Lite Grinder



MODEL TL-9
PART # 58900



PARTS FINDER

**Search Website
by Part Number**



**Search Manual
Library For Parts
Manual & Lookup Part
Numbers – Purchase
or Request Quote**

Search Manuals

Enter your information to help us find the right parts manual for your machine.

* Brand:

* Model:

* Serial:

* Part Number:

SEARCH

**Can't Find Part or
Manual? Request Help
by Manufacturer,
Model & Description**

Parts Order Form

Please fill in the following information to help us find the right part for your machine.

Manufacturer:	<input type="text"/>
Model:	<input type="text"/>
Description:	<input type="text"/>
Part Number:	<input type="text"/>
Quantity:	<input type="text"/>
Notes:	<input type="text"/>

Submit

Discount-Equipment.com is your online resource for quality parts & equipment.

Florida: **561-964-4949** Outside Florida TOLL FREE: **877-690-3101**

Need parts?

Click on this link: <http://www.discount-equipment.com/category/5443-parts/> and choose one of the options to help get the right parts and equipment you are looking for. Please have the machine model and serial number available in order to help us get you the correct parts. If you don't find the part on the website or on one of the online manuals, please fill out the request form and one of our experienced staff members will get back to you with a quote for the right part that your machine needs.

We sell worldwide for the brands: Genie, Terex, JLG, MultiQuip, Mikasa, Essick, Whiteman, Mayco, Toro Stone, Diamond Products, Generac Magnum, Airman, Haulotte, Barreto, Power Blanket, Nifty Lift, Atlas Copco, Chicago Pneumatic, Allmand, Miller Curber, Skyjack, Lull, Skytrak, Tsurumi, Husquvarna Target, Stow, Wacker, Sakai, Mi-T-M, Sullair, Basic, Dynapac, MBW, Weber, Bartell, Bennar Newman, Haulotte, Ditch Runner, Menegotti, Morrison, Contec, Buddy, Crown, Edco, Wyco, Bomag, Laymor, EZ Trench, Bil-Jax, F.S. Curtis, Gehl Pavers, Heli, Honda, ICS/PowerGrit, IHI, Partner, Imer, Clipper, MMD, Koshin, Rice, CH&E, General Equipment, Amida, Coleman, NAC, Gradall, Square Shooter, Kent, Stanley, Tamco, Toku, Hatz, Kohler, Robin, Wisconsin, Northrock, Oztec, Toker TK, Rol-Air, APT, Wylie, Ingersoll Rand / Doosan, Innovatech, Con X, Ammann, Mecalac, Makinex, Smith Surface Prep, Small Line, Wanco, Yanmar

READ AND UNDERSTAND THE OPERATORS INSTRUCTION MANUAL *THOROUGHLY* BEFORE ATTEMPTING TO OPERATE THIS EQUIPMENT.



Death or serious injury could occur if this machine is used improperly.



SAFETY MESSAGES

- Safety Instructions are preceded by a graphic alert symbol of DANGER, WARNING, or CAUTION.



Indicates an imminent hazard which, if not avoided, will result in death or serious injury.



Indicates an imminent hazard which, if not avoided, can result in death or serious injury.



Indicates hazards which, if not avoided, could result in serious injury and or damage to the equipment.

GASOLINE/PROPANE POWERED EQUIPMENT



- Engine exhaust from this product contains chemicals known to the State of California to cause cancer, birth defects or other reproductive harm.



- Gasoline is extremely flammable and poisonous. It should only be dispensed in well ventilated areas, and with a cool engine.

- Small gasoline engines produce high concentrations of carbon monoxide (CO) example: a 5 HP 4 cycle engine operation in an enclosed 100,000 cu. ft. area with only one change of air per hour is capable of providing deadly concentrations of CO in less than fifteen minutes. Five changes of air in the same area will produce noxious fumes in less than 30 minutes. Gasoline or propane powered equipment should not be used in enclosed or partially enclosed areas. Symptoms of CO poisoning include, headache, nausea, weakness, dizziness, visual problems and loss of consciousness. If symptoms occur - get into fresh air and seek medical attention immediately.

ELECTRICAL POWERED EQUIPMENT



Extreme care must be taken when operating electric models with water present: Ensure power cord is properly grounded, is attached to a Ground-Fault-Interrupter (GFI) outlet, and is undamaged.

- Check all electrical cables - be sure connections are tight and cable is continuous and in good condition. Be sure cable is correctly rated for both the operating current and voltage of this equipment.
- Improper connection of the equipment-grounding conductor can result in a risk of electric shock. Check with qualified electrician or service person if there is any doubt as to whether the outlet is properly grounded. Adhere to all local codes and ordinances.
- **NOTE:** In the event of a malfunction or breakdown, grounding provides a path of least resistance for the electric current to dissipate. The motor is equipped with a grounded plug and must be connected to an outlet that is properly installed and properly grounded. DO NOT modify the plug provided on the motor. If the plug does not fit the outlet have a qualified electrician install the proper receptacle.
- Switch motor OFF **before** disconnecting power.

- Do not disconnect power by pulling cord. To disconnect, grasp the plug, not the cord.
- Unplug power cord at the machine when not in use and before servicing.

GENERAL INSTRUCTIONS

- Equipment should only be operated by trained personnel in good physical condition and mental health (not fatigued). The operator and maintenance personnel must be physically able to handle the bulk weight and power of this equipment.
- This is a one person tool. Maintain a safe operating distance to other personnel. It is the **operators' responsibility** to keep other people (workers, pedestrians, bystanders, etc.) away during operation. Block off the work area in all directions with roping, safety netting, etc. for a safe distance. Failure to do so may result in others being injured by flying debris or exposing them to harmful dust and noise.
- This equipment is intended for commercial use only.
- For the operator's safety and the safety of others, always keep all guards in place during operation.
- Never let equipment run unattended.



- Personal Protection Equipment and proper safety attire must be worn when operating this machinery. The operator must wear approved safety equipment appropriate for the job such as hard hat and safety shoes when conditions require. Hearing protection **MUST** be used (operational noise levels of this equipment may exceed 85db). Eye protection **MUST** be worn at all times.



Keep body parts and loose clothing away from moving parts. Failure to do so could result in dismemberment or death.

- Do not modify the machine.
- Stop motor/engine when adjusting or servicing this equipment.



Maintain a safe operating distance from flammable materials. Sparks from the cutting-action of this machine can ignite flammable materials or vapors.

DUST WARNING



Some dust created by power sanding, sawing, grinding, drilling, and other construction activities contains chemicals known to cause cancer, birth defects, or other reproductive harm. Some examples of these chemicals are:

- Lead from lead-based paints, and
 - Crystalline silica from bricks and concrete and other masonry products.
- Your risk of exposure to these chemicals varies depending on how often you do this type of work. To reduce your risk: work in a well ventilated area, use a dust control system, such as an industrial-style vacuum, and wear approved personal safety equipment, such as a dust/particle respirator designed to filter out microscopic particles.

PARTS LIST MANUAL

Magna-Trap™ 9” Turbo-Lite Grinder

MODEL TL-9

TABLE OF CONTENTS

<u>Section</u>	<u>Page Number</u>
Safety Messages and General Instructions	2
How To Order Replacement Parts	3
Illustration 1: Main Grouping	4, 5
Illustration 2: Motor & Magna-Trap™ Disc Grouping	6, 7
Wiring Diagram	8
Decal Sheet	9
Notes	11
Limited Equipment Warranty of Sale - Terms & Conditions	12 (Back Page)

ILLUSTRATION 1: MAIN GROUPING

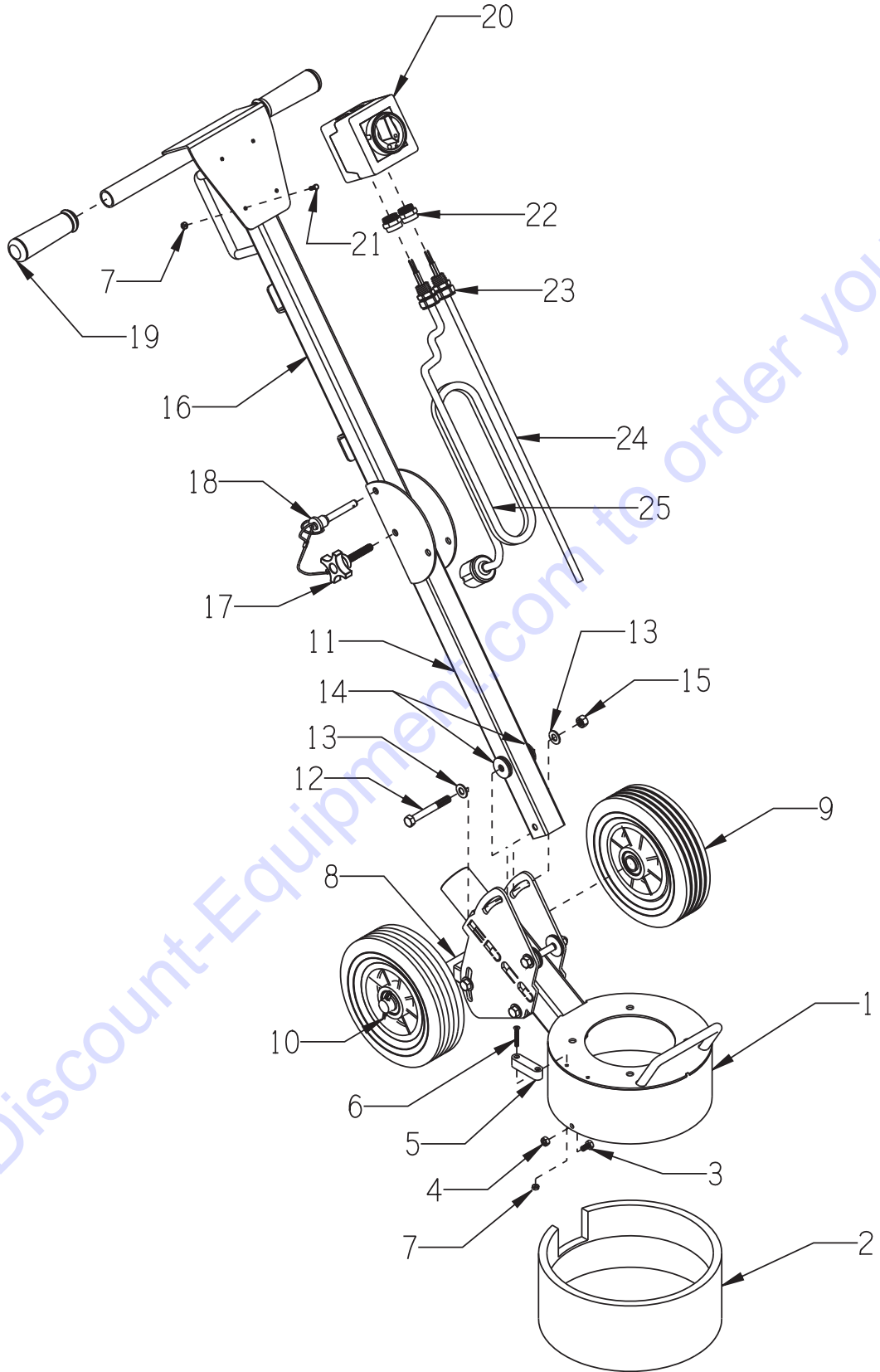

Go to Discount-Equipment.com to order your parts

PARTS LISTING - ILLUSTRATION 1 : MAIN GROUPING			
ITEM #	PART #	DESCRIPTION	QTY.
1	58950	MAIN FRAME, TL-9	1
2	58956	DUST RING, TL-9	1
3	10834	SCREW, CAP 1/4-20 X 1/2 ZINC	2
4	10015	NUT, HEX LOCK 1/4-20 ZINC	2
5	59117	LEVEL, SCREW ON	1
6	11871	SCREW, MACHINE FHP 8-32 X 1-1/4	2
7	10462	NUT, KEPS LOCK 8-32 ZINC	6
8	58951	REAR AXLE, TL-9	1
9	79013	WHEEL, 8 X 2-1/2 X 3/4"BRG.POLY HUB	2
10	10306	PIN, COTTER 3/16 X 1-1/2	2
11	58952	LOWER HANDLE, TL-9	1
12	10885	SCREW, CAP 3/8-24 X 3	4
13	10025	WASHER, FLAT 3/8 SAE ZINC	8
14	11695	WASHER, 1.1210 X .3750 X .1280	8
15	10152	NUT, HEX NYLON LOCK 3/8-24 ZINC	4
16	58953	UPPER HANDLE, TL-9	1
17	58963	FOUR ARM KNOB, 3/8-16 X 2-1/2, TL-9	1
18	58959	QUICK RELEASE PIN W/ LANYARD, TL-9	1
19	10608	GRIP, HAND 1" MODEL AT	2
20	77043	SWITCH, ROTARY CAM ON/OFF, LOVATO	1
		REPLACEMENT PARTS:	
	77043-2.....SWITCH HANDLE, PADLOCKABLE, LOVATO	1
	77043-4.....GASKET RING, OPERATOR, LOVATO	1
21	11663	SCREW, MACHINE 8-32 X 1/2 RHCD ZINC	4
22	77043-1	SWITCH ADAPTER, PG16 TO 1/2"NPT	2
23	40066	STRAIN RELIEF 1/2NPT X .350-.450"	2
24	58964	MOTOR CORD 12/3 AWG SJ00W X 56"	1
25	58965	POWER CORD 12/3 X 10' AWG SJ00W	1

ILLUSTRATION 2: MOTOR & MAGNA-TRAP™ DISC GROUPING

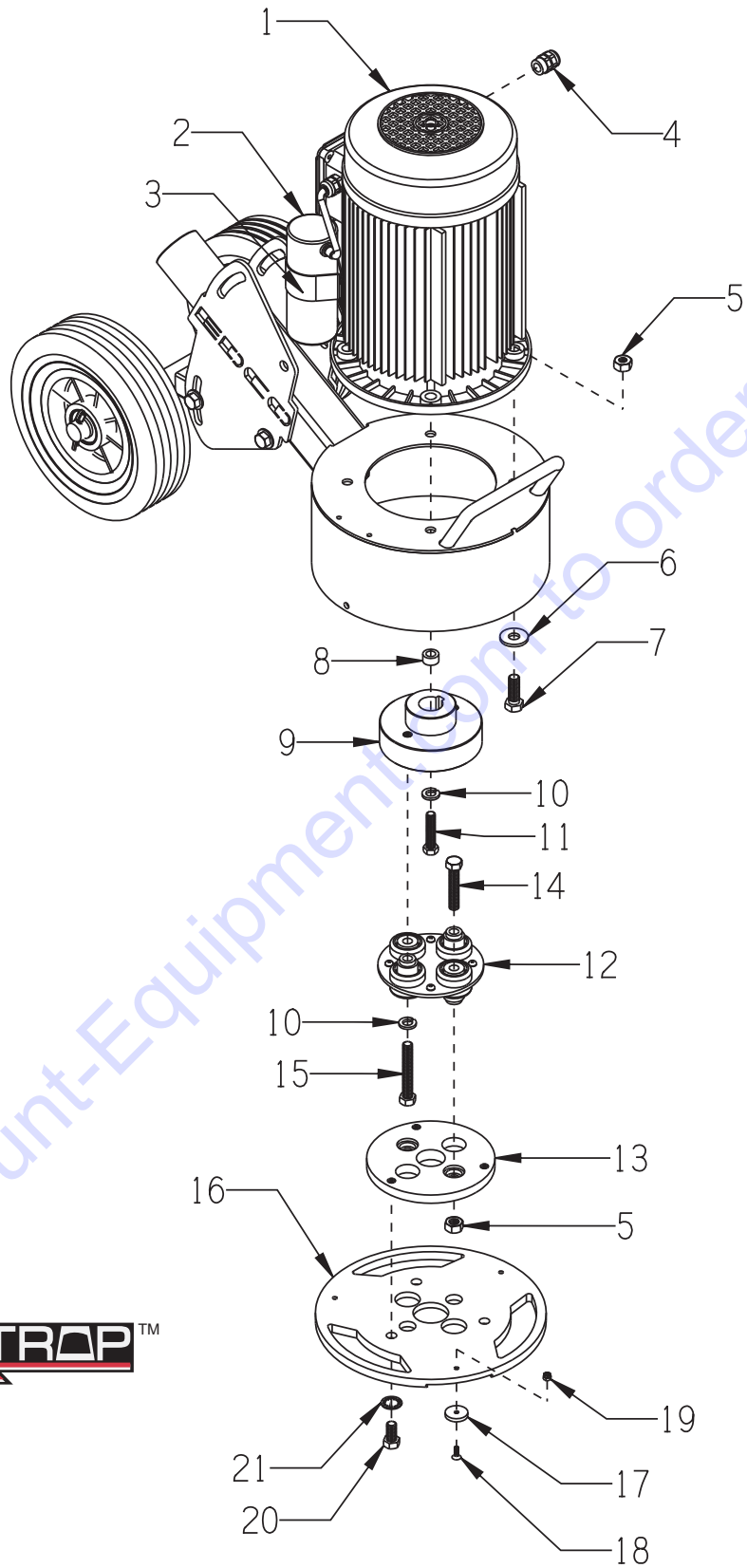

**PARTS LISTING - ILLUSTRATION 2:
MOTOR & MAGNA-TRAP™ DISC GROUPING**

ITEM #	PART #	DESCRIPTION	QTY.
1	16091	MOTOR, EMGR 1.1KW 115V 60HZ, TL-9	1
2	58961	CAPACITOR, START, EMGR MOTOR	2
3	58962	CLAMP, LOOM, FOR CAPACITOR	2
4	28506	STRAIN RELIEF, M20X1.5 .276-.512"	1
5	10810	NUT, HEX LOCK 3/8-16 ZINC	6
6	10025	WASHER, FLAT 3/8 SAE ZINC	4
7	10333	SCREW, CAP 3/8-16 X 1-1/4	4
8	58960	HEAD BRACKET, SPACER, TL-9	1
9	58954	HEAD BRACKET, TL-9	1
10	10811	WASHER, LOCK 3/8 ZINC	3
11	11775	SCREW, CAP M8-1.25 X 40MM	1
12	86017	COUPLING, MORFLEX 402 CENTER	1
13	58955	TOOL BRACKET, TL-9	1
14	10317	SCREW, CAP 3/8-16 X 2	2
15	11669	SCREW, CAP 3/8-16 X 2-1/2 FULL THD	2
16	58903	9" MAGNA-TRAP DISC W/ MAGNETS, TL-9 INCLUDES ITEMS (16,17,18,19)	1
17	36064	MAGNET, NEODYMIUM RING 7/8 X 1/8	3
18	10647	SCREW, FLAT HD PHILLIPS 8-32 X 1/2	3
19	10462	NUT, KEPS LOCK 8-32 ZINC	3
20	10055	SCREW, CAP 3/8-16 X 1	3
21	10453	WASHER, LOCK, INT. TOOTH 3/8"	3

WIRING DIAGRAM

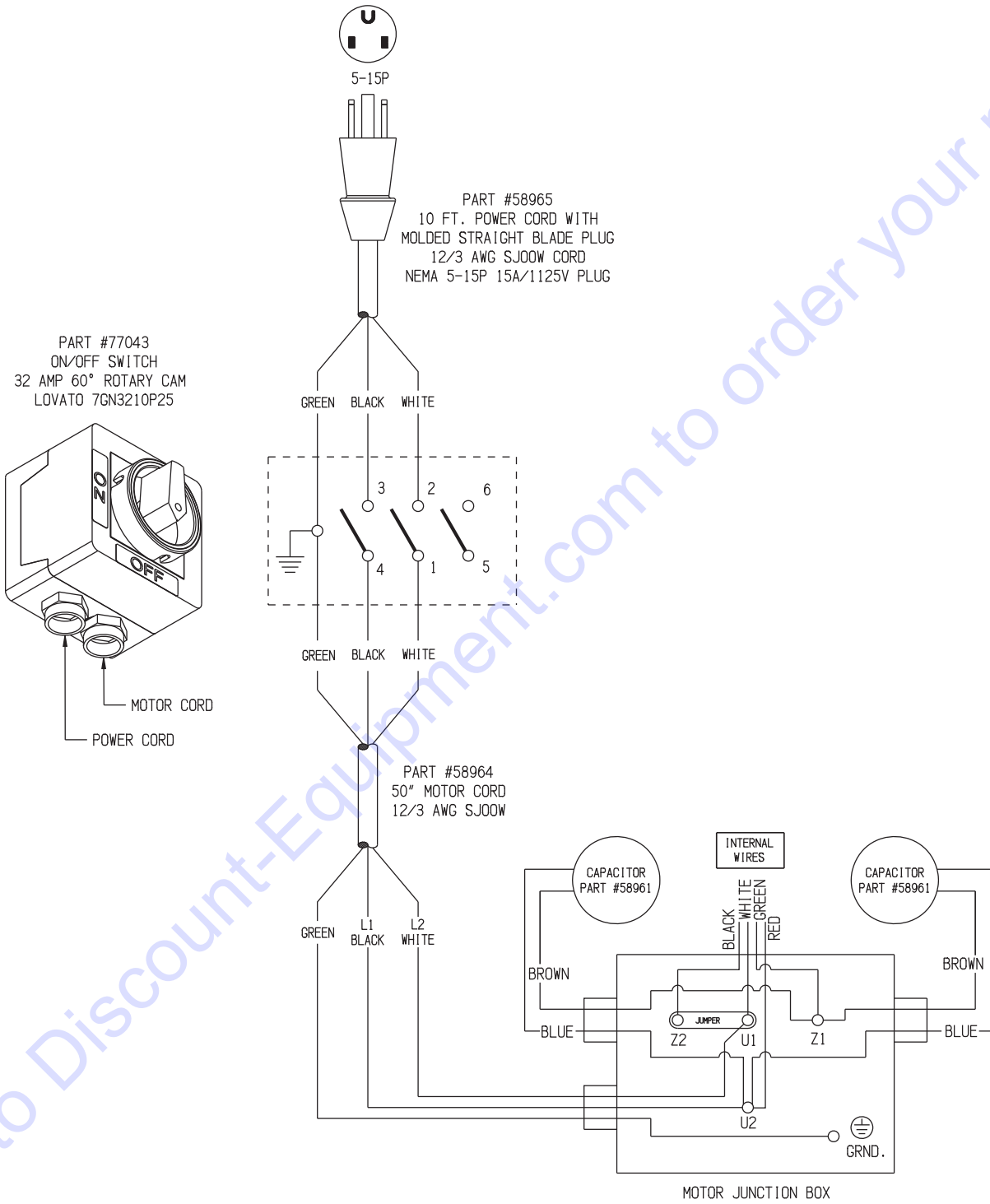

Go to Discount-Equipment.com to order your parts

PARTS FINDER

**Search Website
by Part Number**



**Search Manual
Library For Parts
Manual & Lookup Part
Numbers – Purchase
or Request Quote**

Search Manuals

Enter your information to help us find the right parts manual for your machine.

* Brand:

* Model:

* Serial:

* Part Number:

SEARCH

**Can't Find Part or
Manual? Request Help
by Manufacturer,
Model & Description**

Parts Order Form

Please fill in the following information to help us find the right part for your machine.

MANUFACTURER:

MODEL:

DESCRIPTION:

SEARCH

Discount-Equipment.com is your online resource for quality parts & equipment.

Florida: **561-964-4949** Outside Florida TOLL FREE: **877-690-3101**

Need parts?

Click on this link: <http://www.discount-equipment.com/category/5443-parts/> and choose one of the options to help get the right parts and equipment you are looking for. Please have the machine model and serial number available in order to help us get you the correct parts. If you don't find the part on the website or on one of the online manuals, please fill out the request form and one of our experienced staff members will get back to you with a quote for the right part that your machine needs.

We sell worldwide for the brands: Genie, Terex, JLG, MultiQuip, Mikasa, Essick, Whiteman, Mayco, Toro Stone, Diamond Products, Generac Magnum, Airman, Haulotte, Barreto, Power Blanket, Nifty Lift, Atlas Copco, Chicago Pneumatic, Allmand, Miller Curber, Skyjack, Lull, Skytrak, Tsurumi, Husquvarna Target, Stow, Wacker, Sakai, Mi-T-M, Sullair, Basic, Dynapac, MBW, Weber, Bartell, Bennar Newman, Haulotte, Ditch Runner, Menegotti, Morrison, Contec, Buddy, Crown, Edco, Wyco, Bomag, Laymor, EZ Trench, Bil-Jax, F.S. Curtis, Gehl Pavers, Heli, Honda, ICS/PowerGrit, IHI, Partner, Imer, Clipper, MMD, Koshin, Rice, CH&E, General Equipment, Amida, Coleman, NAC, Gradall, Square Shooter, Kent, Stanley, Tamco, Toku, Hatz, Kohler, Robin, Wisconsin, Northrock, Oztec, Toker TK, Rol-Air, APT, Wylie, Ingersoll Rand / Doosan, Innovatech, Con X, Ammann, Mecalac, Makinex, Smith Surface Prep, Small Line, Wanco, Yanmar