



REVISED STARTING
SERIAL # 120610104

PARTS LIST MANUAL

MODEL TG10



GASOLINE MODEL

PROPANE MODEL

ELECTRIC MODEL

10" TURBO GRINDERS

SKU #	MODEL #	POWER OPTION
56600	TG10-11H	HONDA GASOLINE ENGINE MODEL GXV340UT2-DX3
56700	TG10-13P	KAWASAKI PROPANE ENGINE MODEL FH381V
56900	TG10-5B/230/1	BALDOR ELECTRIC MOTOR 5HP 1PH 60Hz 230V
56800-230	TG10-5B/230/3	BALDOR ELECTRIC MOTOR 5HP 3PH 60Hz 230V
56800-460	TG10-5B/460/3	BALDOR ELECTRIC MOTOR 5HP 3PH 60Hz 460V
56800-50/220	TG10-5B/50/220/3	BALDOR ELECTRIC MOTOR 5HP 3PH 50Hz 220V
56800-50/380	TG10-5B/50/380/3	BALDOR ELECTRIC MOTOR 5HP 3PH 50Hz 380V
56800-50/440	TG10-5B/50/440/3	BALDOR ELECTRIC MOTOR 5HP 3PH 50Hz 440V



A Division of Equipment Development Company, Inc.

PARTS FINDER

**Search Website
by Part Number**



**Search Manual
Library For Parts
Manual & Lookup Part
Numbers – Purchase
or Request Quote**

Search Manuals

Enter your information to help us find the right parts manual for your machine.

* Brand:

* Model:

* Serial:

* Part Number:

SEARCH

**Can't Find Part or
Manual? Request Help
by Manufacturer,
Model & Description**

Parts Order Form

Please fill in the following information to help us find the right part for your machine.

Manufacturer:	<input type="text"/>
Model:	<input type="text"/>
Description:	<input type="text"/>
Part Number:	<input type="text"/>
Quantity:	<input type="text"/>
Notes:	<input type="text"/>

Submit

Discount-Equipment.com is your online resource for quality parts & equipment.

Florida: **561-964-4949** Outside Florida TOLL FREE: **877-690-3101**

Need parts?

Click on this link: <http://www.discount-equipment.com/category/5443-parts/> and choose one of the options to help get the right parts and equipment you are looking for. Please have the machine model and serial number available in order to help us get you the correct parts. If you don't find the part on the website or on one of the online manuals, please fill out the request form and one of our experienced staff members will get back to you with a quote for the right part that your machine needs.

We sell worldwide for the brands: Genie, Terex, JLG, MultiQuip, Mikasa, Essick, Whiteman, Mayco, Toro Stone, Diamond Products, Generac Magnum, Airman, Haulotte, Barreto, Power Blanket, Nifty Lift, Atlas Copco, Chicago Pneumatic, Allmand, Miller Curber, Skyjack, Lull, Skytrak, Tsurumi, Husquvarna Target, Stow, Wacker, Sakai, Mi-T-M, Sullair, Basic, Dynapac, MBW, Weber, Bartell, Bennar Newman, Haulotte, Ditch Runner, Menegotti, Morrison, Contec, Buddy, Crown, Edco, Wyco, Bomag, Laymor, EZ Trench, Bil-Jax, F.S. Curtis, Gehl Pavers, Heli, Honda, ICS/PowerGrit, IHI, Partner, Imer, Clipper, MMD, Koshin, Rice, CH&E, General Equipment, Amida, Coleman, NAC, Gradall, Square Shooter, Kent, Stanley, Tamco, Toku, Hatz, Kohler, Robin, Wisconsin, Northrock, Oztec, Toker TK, Rol-Air, APT, Wylie, Ingersoll Rand / Doosan, Innovatech, Con X, Ammann, Mecalac, Makinex, Smith Surface Prep, Small Line, Wanco, Yanmar

READ AND UNDERSTAND THE OPERATORS INSTRUCTION MANUAL THOROUGHLY BEFORE ATTEMPTING TO OPERATE THIS EQUIPMENT.



Death or serious injury could occur if this machine is used improperly.



SAFETY MESSAGES

- Safety Instructions are preceded by a graphic alert symbol of DANGER, WARNING, or CAUTION.



Indicates an imminent hazard which, if not avoided, will result in death or serious injury.



Indicates an imminent hazard which, if not avoided, can result in death or serious injury.



Indicates hazards which, if not avoided, could result in serious injury and or damage to the equipment.

GASOLINE/PROPANE POWERED EQUIPMENT



• Engine exhaust from this product contains chemicals known to the State of California to cause cancer, birth defects or other reproductive harm.



Gasoline is extremely flammable and poisonous. It should only be dispensed in well ventilated areas, and with a cool engine.

- Small gasoline engines produce high concentrations of carbon monoxide (CO) example: a 5 HP 4 cycle engine operation in an enclosed 100,000 cu. ft. area with only one change of air per hour is capable of providing deadly concentrations of CO in less than fifteen minutes. Five changes of air in the same area will produce noxious fumes in less than 30 minutes. Gasoline or propane powered equipment should not be used in enclosed or partially enclosed areas. Symptoms of CO poisoning include, headache, nausea, weakness, dizziness, visual problems and loss of consciousness. If symptoms occur - get into fresh air and seek medical attention immediately.

ELECTRICAL POWERED EQUIPMENT



Extreme care must be taken when operating electric models with water present: Ensure power cord is properly grounded, is attached to a Ground-Fault-Interrupter (GFI) outlet, and is undamaged.

- Check all electrical cables - be sure connections are tight and cable is continuous and in good condition. Be sure cable is correctly rated for both the operating current and voltage of this equipment.
- Improper connection of the equipment-grounding conductor can result in a risk of electric shock. Check with qualified electrician or service person if there is any doubt as to whether the outlet is properly grounded. Adhere to **all** local codes and ordinances.
- **NOTE:** In the event of a malfunction or breakdown, grounding provides a path of least resistance for the electric current to dissipate. The motor is equipped with a grounded plug and must be connected to an outlet that is properly installed and properly grounded. DO NOT modify the plug provided on the motor. If the plug does not fit the outlet have a qualified electrician install the proper receptacle.
- Switch motor OFF **before** disconnecting power.

- Do not disconnect power by pulling cord. To disconnect, grasp the plug, not the cord.
- Unplug power cord at the machine when not in use and before servicing.

GENERAL INSTRUCTIONS

- Equipment should only be operated by trained personnel in good physical condition and mental health (not fatigued). The operator and maintenance personnel must be physically able to handle the bulk weight and power of this equipment.
- This is a one person tool. Maintain a safe operating distance to other personnel. It is the **operators' responsibility** to keep other people (workers, pedestrians, bystanders, etc.) away during operation. Block off the work area in all directions with roping, safety netting, etc. for a safe distance. Failure to do so may result in others being injured by flying debris or exposing them to harmful dust and noise.
- This equipment is intended for commercial use only.
- For the operator's safety and the safety of others, always keep all guards in place during operation.
- Never let equipment run unattended.



- Personal Protection Equipment and proper safety attire must be worn when operating this machinery. The operator must wear approved safety equipment appropriate for the job such as hard hat and safety shoes when conditions require. Hearing protection **MUST** be used (operational noise levels of this equipment may exceed 90db). Eye protection **MUST** be worn at all times.



Keep body parts and loose clothing away from moving parts. Failure to do so could result in dismemberment or death.

- Do not modify the machine.
 - Stop motor/engine when adjusting or servicing this equipment.
- Maintain a safe operating distance from flammable materials. Sparks from the cutting-action of this machine can ignite flammable materials or vapors.



DUST WARNING



Some dust created by power sanding, sawing, grinding, drilling, and other construction activities contains chemicals known to cause cancer, birth defects, or other reproductive harm. Some examples of these chemicals are:

- Lead from lead-based paints, and
 - Crystalline silica from bricks and concrete and other masonry products.
- Your risk of exposure to these chemicals varies depending on how often you do this type of work. To reduce your risk: work in a well ventilated area, use a dust control system, such as an industrial-style vacuum, and wear approved personal safety equipment, such as a dust/particle respirator designed to filter out microscopic particles.

PARTS LIST MANUAL

MODEL TG10

10" TURBO GRINDERS

TABLE OF CONTENTS

<u>Section</u>	<u>Page Number</u>
Safety Messages and General Instructions	2
How To Order Replacement Parts	3
Illustration 1: Main Grouping	4,5
Illustration 2: Optional Leveling System	6
Illustration 3: Optional Ball Caster Depth Stop Kit	7
Illustration 4: Water Valve Grouping	8
Illustration 5: Bearing Hub & Head Assembly	9
Illustration 6: Rigid Head Assembly (Standard)	10
Illustration 7: Flex Head Assembly (Optional)	11
Illustration 8: Gasoline Engine & Belt Drive Grouping	12, 13
Illustration 9: Propane Engine & Belt Drive Grouping	14, 15
Illustration 10: Propane Tank Grouping	16, 17
Illustration 11: Single-Phase Motor & Belt Drive Grouping	18, 19
Illustration 12: Three-Phase Motor & Belt Drive Grouping	20, 21
Wiring Diagram for Rotary Cam Switch (Single Phase)	22
Wiring Diagram for Starter (Three Phase)	23
Motor Wiring Diagram 1-Phase 60 Hz 230V	24
Motor Wiring Diagram 3-Phase 60 Hz 230/460V	25
Motor Wiring Diagram 3-Phase 50 Hz 220/380/440V	26
Notes	27
Limited Equipment Warranty of Sale - Terms & Conditions	28 (Back Page)



A Division of Equipment Development Company, Inc.

ILLUSTRATION 1: MAIN GROUPING

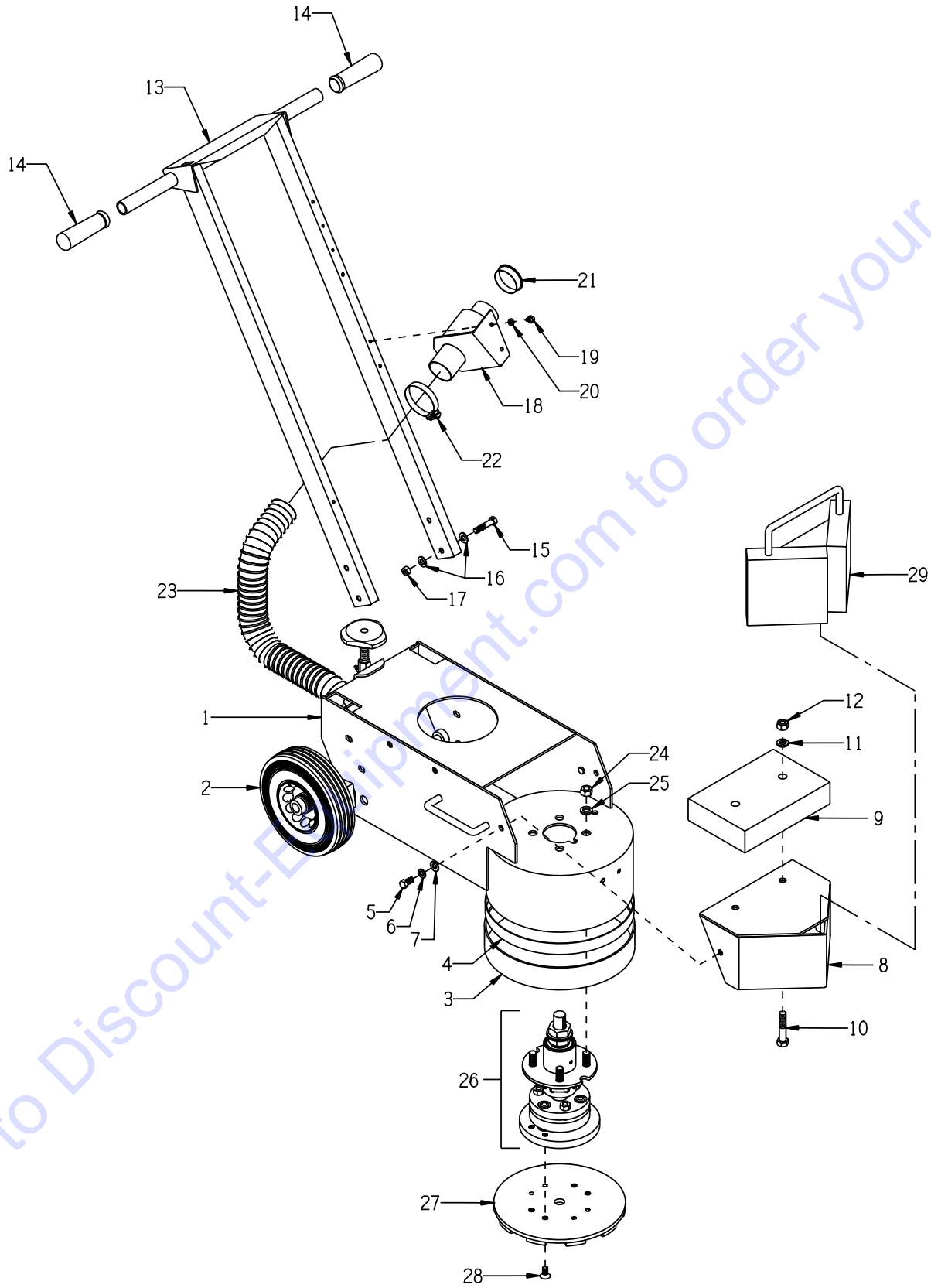

PARTS LISTING - ILLUSTRATION 1 : MAIN GROUPING			
ITEM #	PART #	DESCRIPTION	QTY.
1	86336	MAIN FRAME	1
2	-----	LEVELING SYSTEM (REFER TO ILLUS. 2 FOR BREAKDOWN)	-
3	86352	RUBBER SKIRT W/ VELCRO, 2 X 36-1/8	1
4	-----	VELCRO-HOOK ONLY, 1" X 34-1/2", TG-10 (INCLUDED W/ ITEM 3, PLACED AROUND BOTTOM OF SHROUD)	1
5	10907	SCREW, CAP 3/8-16 X 3/4	2
6	10811	WASHER, LOCK 3/8 ZINC	2
7	10025	WASHER, FLAT 3/8 SAE ZINC	2
8	86303	HOOD	1
9	86345	WEIGHT BLOCK, 30 LB. 9 X 6 X 2 (ELECTRIC MODELS ONLY)	1
10	10499	SCREW, CAP 1/2-13 X 3	2
11	10045	WASHER, LOCK 1/2 ZINC	2
12	10417	NUT, HEX 1/2-13 ZINC	2
13	86304	HANDLE BAR	1
14	10608	GRIP, HAND 1" MODEL AT	2
15	10029	SCREW, CAP 3/8-24 X 1-3/4	4
16	10025	WASHER, FLAT 3/8 SAE ZINC	8
17	10004	NUT, HEX LOCK 3/8-24 ZINC	4
18	86347	BRACKET, MULTI-VAC PORT 2-3"	1
19	10846	SCREW, CAP STSHW 1/4-20 X 1/2	2
20	10038	WASHER, LOCK 1/4 ZINC	2
21	65021	CAP/PLUG 2" RED PLASTIC, FLANGED	1
22	10766	CLAMP, HOSE, SAE #32, ADJ. TO 2-1/2	2
23	77113	HOSE, FLEX 2"ID X 32"L, GRINDERS	1
24	10072	NUT, HEX 1/2-20 ZINC	4
25	10045	WASHER, LOCK 1/2 ZINC	4
26	86333... 86326...	HEAD ASSEMBLY COMPLETE W/ BEARING HUB* ...RIGID STYLE ...FLEXIBLE STYLE *NOTE: REFER TO ILLUS. 5, 6, AND 7 FOR BREAKDOWNS	1
27	19166... 19167... 86389...	DIAMOND DISC** ...10" - 20 SEG. GENERAL PURPOSE (INCLUDED W/ MACHINE) ...10" - 10 SEG. GENERAL PURPOSE ABRASIVE (OPTIONAL) ...10" QUICK-CHANGE MULTI-ACCESSORY DISC (OPTIONAL) **NOTE: REFER TO ACCESSORY PRICE LIST OR CATALOG FOR OTHER DIAMOND DISC THAT ARE AVAILABLE.	1
28	86108	SCREW, FLAT HD SKT 3/8-24 X 3/4	4
29	86340	OPTIONAL 30 LB. WEIGHT	1



A Division of Equipment Development Company, Inc.

ILLUSTRATION 2: LEVELING SYSTEM

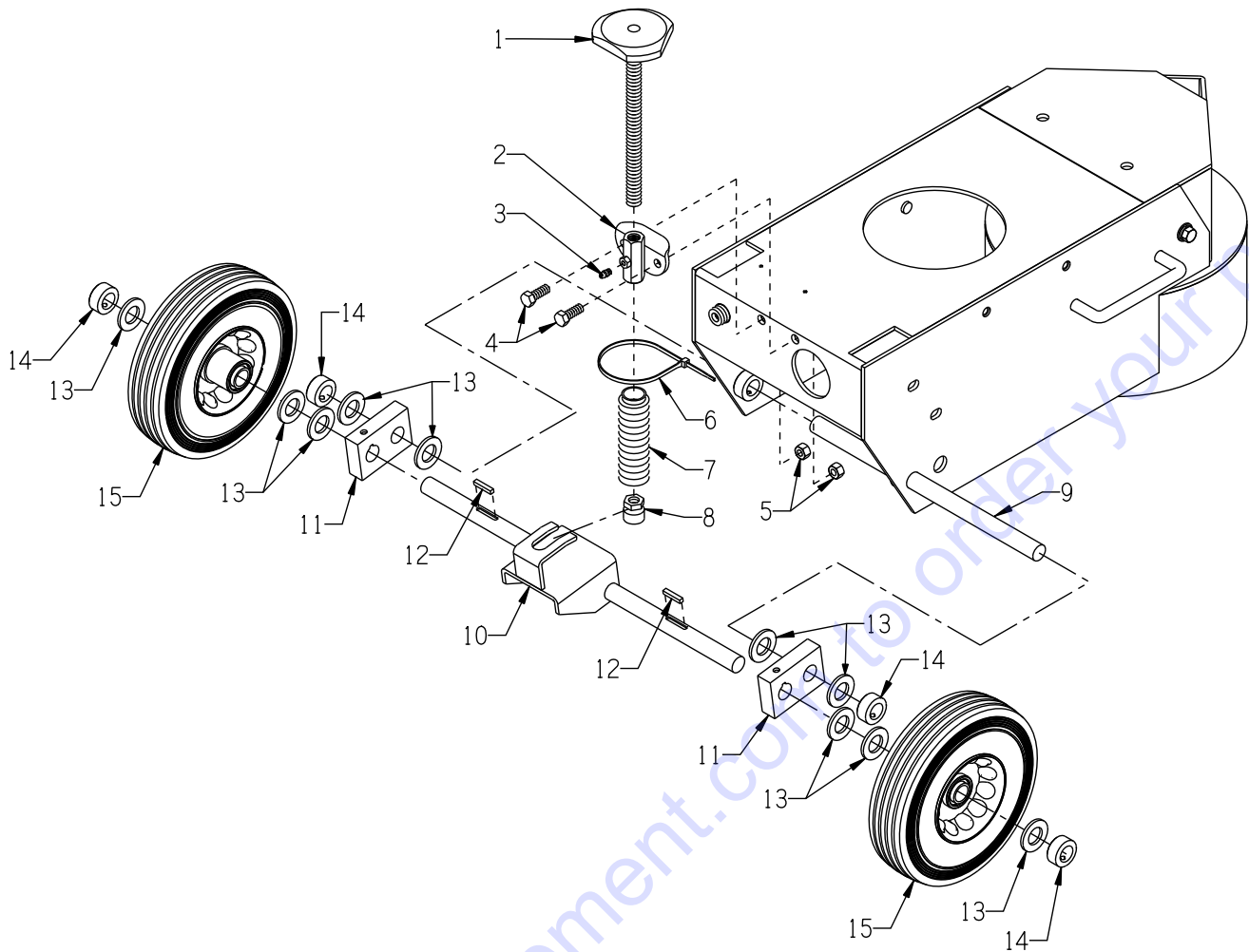

ITEM #	PART #	DESCRIPTION	QTY.
1	86369	CONTROL KNOB, TG10 LEVELING SYS	1
2	86368	MOUNTING PAD, TG10 LEVELING SYS	1
3	10808	FITTING, GREASE 1/4-28 STRAIGHT	1
4	10055	SCREW, CAP 3/8-16 X 1	2
5	10156	NUT, HEX NYLON LOCK 3/8-16	2
6	10982	TIE, CABLE, BLACK NYLON 11-1/4"	1
7	43008	BELLOWS, GAS SPRING (DUST BOOT)	1
8	57413	TOGGLE PAD 1"DIA. X 1"H X 5/8-11	1
9	86377	SHAFT 3/4 X 13-1/4, TG10 LEV. SYS.	1
10	86366	FORK, TG10 LEVELING SYSTEM	1
11	86367	PIVOT BAR, TG10 LEVELING SYSTEM	2
	10052	SCREW, SET 5/16-18 X 3/8 (NOT SHOWN)	2
12	10135	KEY 3/16SQ X 1	2
13	10009	WASHER, FLAT 3/4 SAE ZINC	10
14	10428	COLLAR, LOCKING 3/4"ID	4
15	79013SH	WHEEL, STL.HUB 8 X 2-1/2 X 3/4"BRG.	2

ILLUSTRATION 3: OPTIONAL BALL CASTER DEPTH STOP KIT

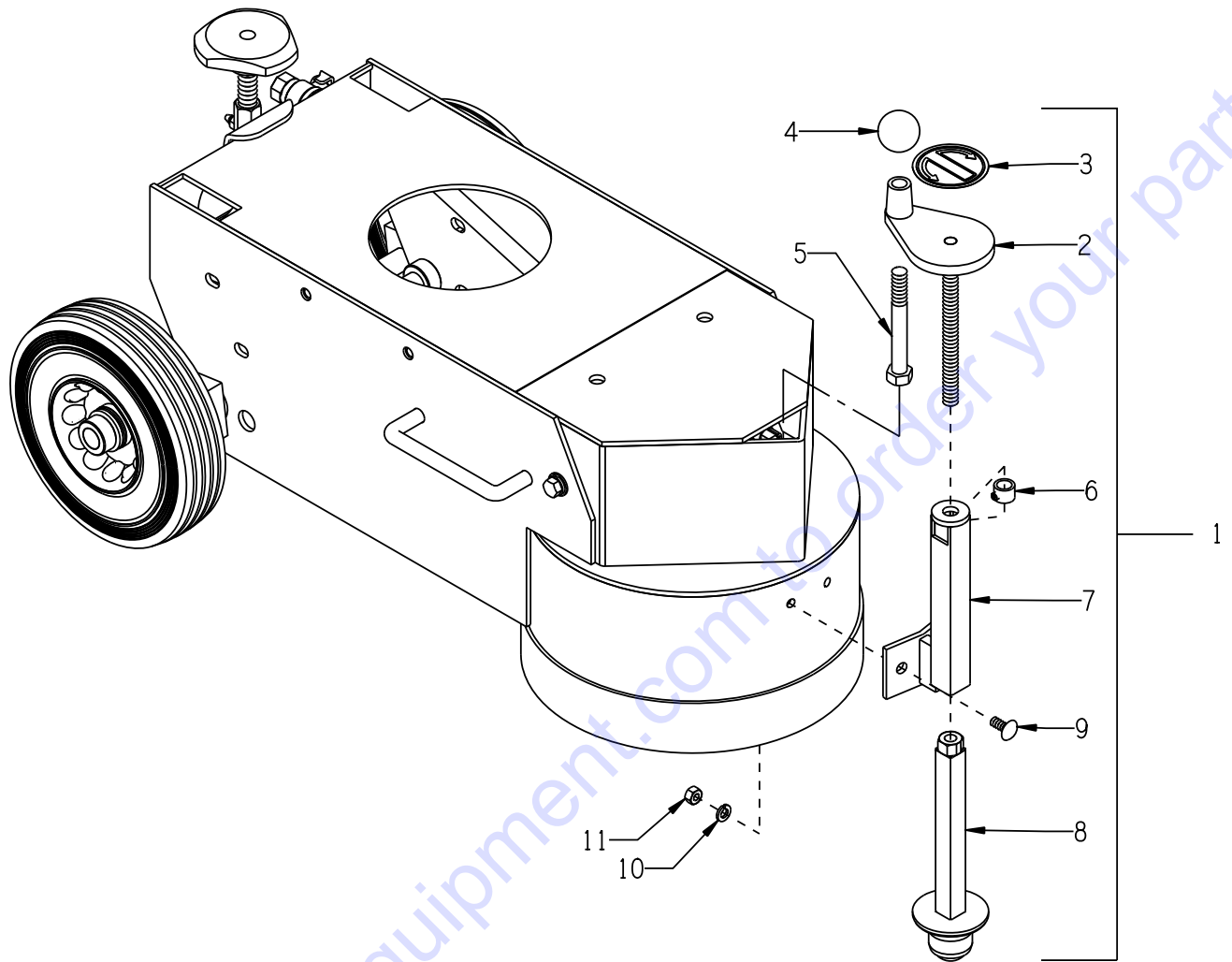

ITEM #	PART #	DESCRIPTION	QTY.
1	86330	BALL CASTER DEPTH STOP KIT (ITEMS 2 THRU 11)	1
2	86313	HANDWHEEL, SMALL W/ ROD 1/2-13 X 6-1/2	1
3	80007	DECAL, DEPTH STOP - DN/UP 2.5"	1
4	10104	KNOB, BALL 1-7/8 W/ 1/2-13THD, BLK.	1
5	81001	SCREW, CAP 1/2-13 X 4	1
6	86316	COLLAR, LOCKING 1/2", MODIFIED 11/16"OD	1
7	86314	SUPPORT, DEPTH STOP	1
8	86315	BALL-CASTER WELDMENT	1
9	10818	BOLT, CARRIAGE 5/16-18 X 3/4 F.T.	2
10	10801	WASHER, LOCK 5/16 ZINC	2
11	10054	NUT, HEX 5/16-18 ZINC	2

ILLUSTRATION 4: WATER VALVE GROUPING

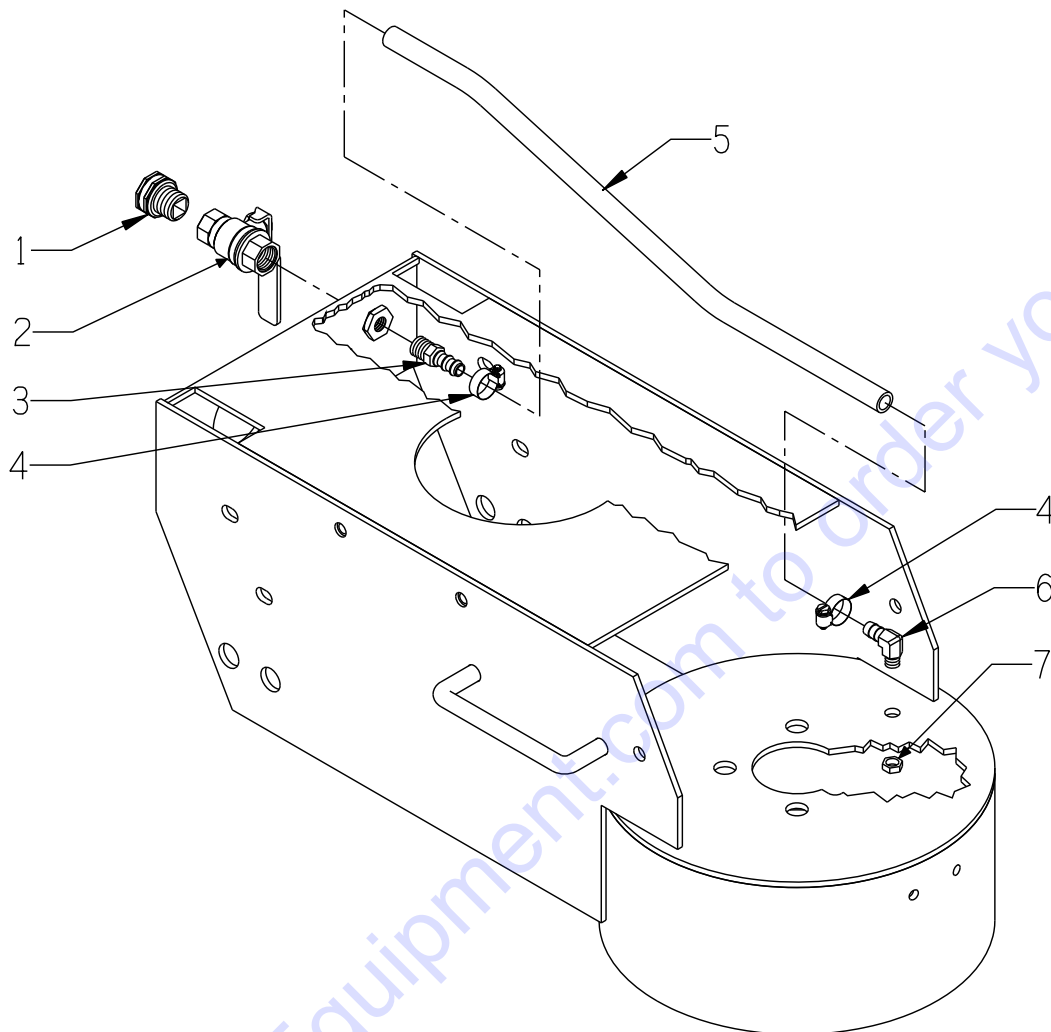

ITEM #	PART #	DESCRIPTION	QTY.
1	80021	CONN., SWIVEL FEM. 3/4HOSE X 1/2MPT (INCLUDES HOSE WASHER)	1
2	10711	VALVE, BALL 1/2 FPT	1
3	50075	BARB, 3/8 HOSE X 1/4MPT (BRASS)	1
4	50069	CLAMP, HOSE, SAE #6, ADJ. TO 13/16	2
5	86329	HOSE 3/8"ID X 19-1/4"L, TG-10	1
6	11562	BARB ELBOW 90, 3/8HOSE X 1/8MPT (BRASS)	1
7	10864	NUT 1/8-27 PIPE THREAD (BRASS)	1

ILLUSTRATION 5: BEARING HUB & HEAD ASSEMBLY

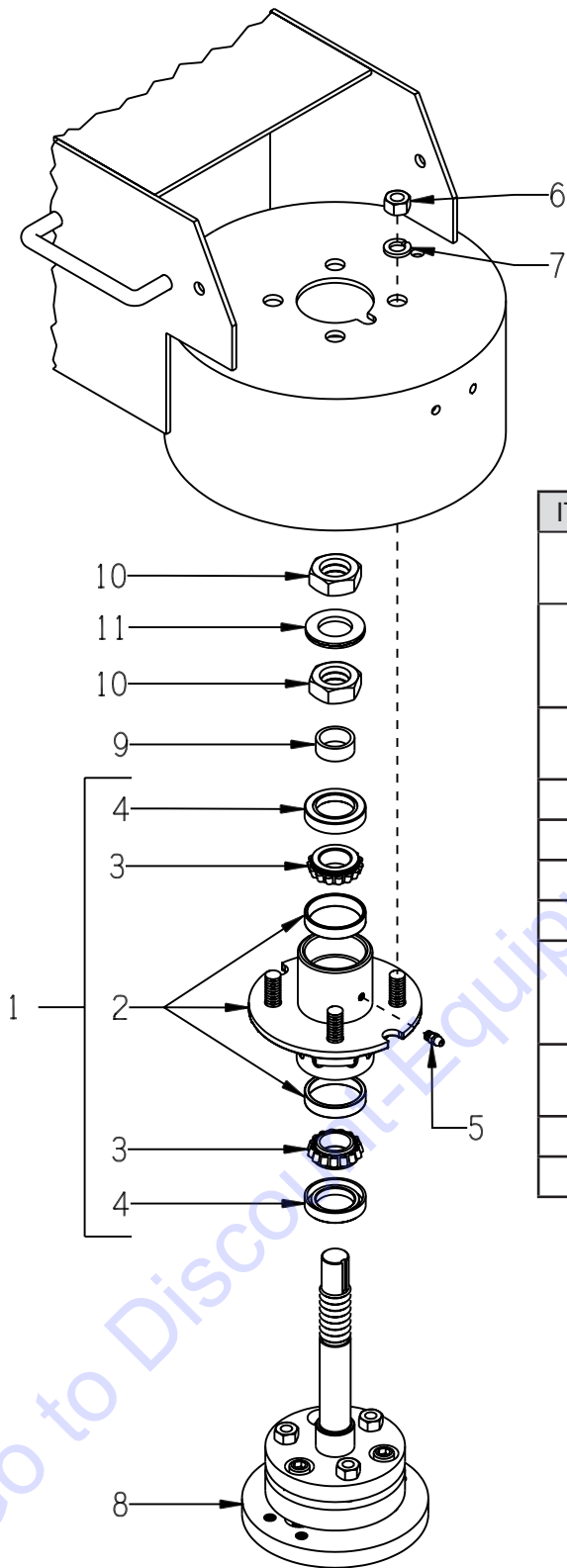

ITEM #	PART #	DESCRIPTION	QTY.
1	86320A	HUB ASSY. W/ BEARINGS & SEALS (INCLUDES ITEMS 2 THRU 5)	1
2	86320HG 86339	HUB W/ RACE CUPS & GREASE HOLE BEARING RACE CUP L44610 NOTE: RACE CUPS ARE PRESSED IN	1 2
3	86321	BEARING, TAPERED ROLLER 1"ID CONE ONLY	2
4	86322	SEAL, BEARING HUB, 1.25 X 1.986	2
5	10808	FITTING, GREASE 1/4-28 STRAIGHT	1
6	10072	NUT, HEX 1/2-20 ZINC	4
7	10045	WASHER, LOCK 1/2 ZINC	4
8	86333LB... 86326LB...	HEAD ASSY. LESS BEARINGRIGID STYLE (SEE ILLUS. 6)FLEX STYLE (SEE ILLUS. 7)	1
9	86319	SPACER, HUB BEARING 1-1/4"OD x 1"ID x 1/2"L	1
10	50020	NUT, HEX JAM 1-14 ZINC GRADE 8	2
11	86323	WASHER, NORD-LOCK 1" (PAIR)	1

ILLUSTRATION 6: RIGID HEAD ASSEMBLY (STANDARD)

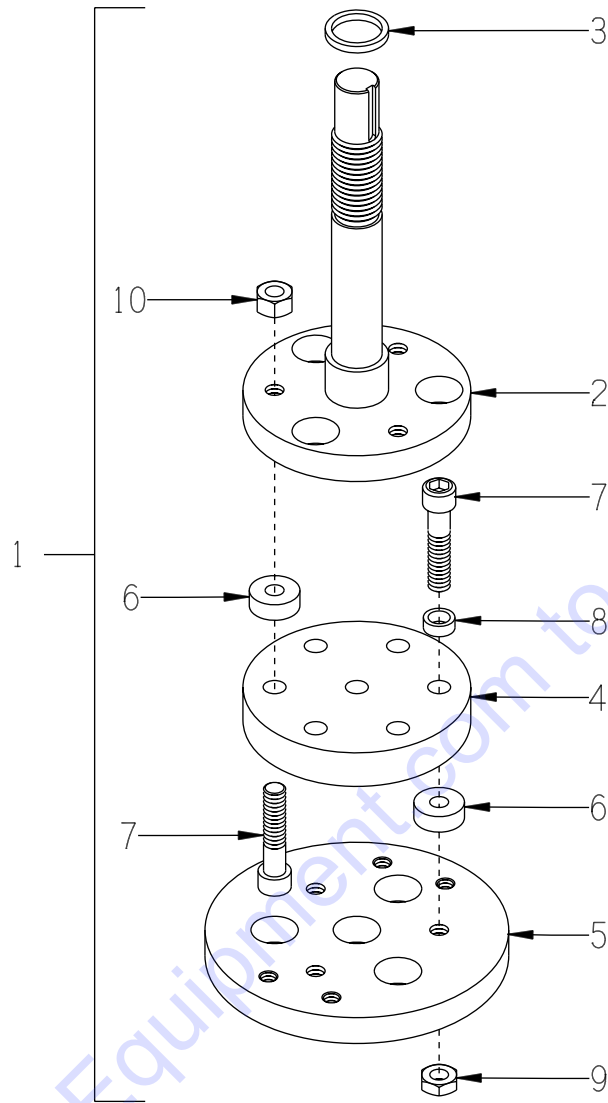

ITEM #	PART #	DESCRIPTION	QTY.
1	86333LB	HEAD ASSY. LESS BRG., RIGID (INCLUDES ITEMS 2-10)	1
2	86334	FLANGE W/ SHAFT, RIGID HEAD	1
3	68017	SPACER 1-1/4"OD X 1"ID X 5/32"THK.	1
4	86132S	SPACER, RIGID HEAD, STEEL	1
5	86133	MOUNTING DISC, RIGID HEAD	1
6	40329	BUSHING, RUBBER 1"OD X 3/8"ID X 3/8	6
7	86111	SCREW, SKT. HD. CAP 7/16-20 X 2 (Grade 8)	6
8	86112	SPACER, STL 5/8"OD X 7/16ID X 1/4TK	3
9	11641	NUT, HEX JAM 7/16-20 ZINC (USE RED LOCTITE)	3
10	10481	NUT, HEX 7/16-20 ZINC (USE RED LOCTITE)	3

ILLUSTRATION 7: FLEX HEAD ASSEMBLY (OPTIONAL)

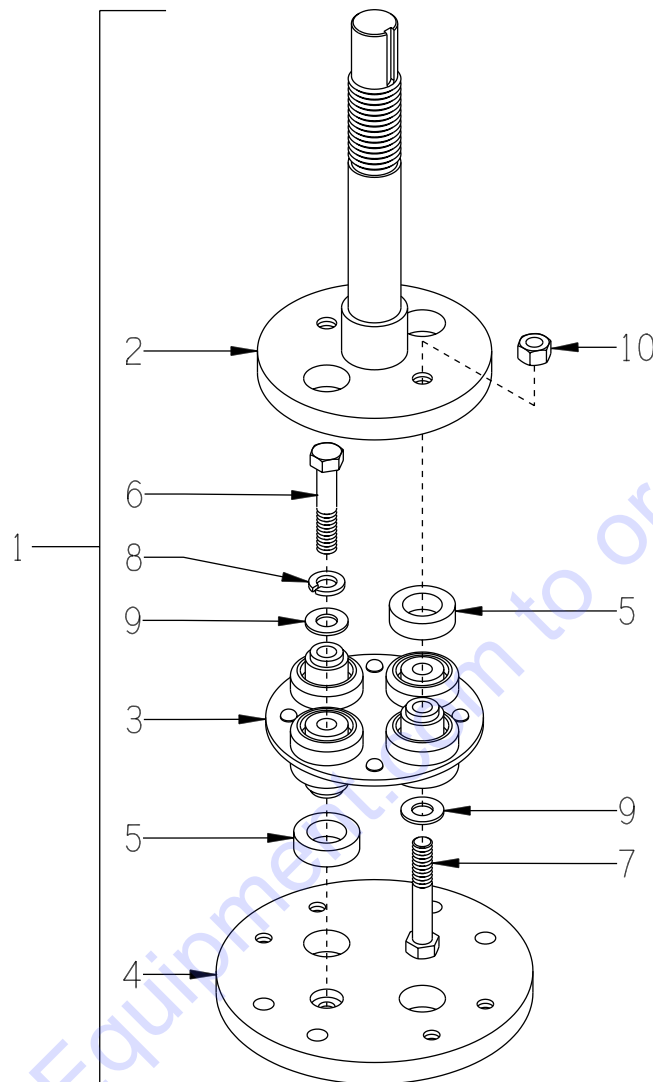

ITEM #	PART #	DESCRIPTION	QTY.
1	86326LB	HEAD ASSY. LESS BRG., FLEX (INCLUDES ITEMS 2-10)	1
2	86308	FLANGE W/ SHAFT, FLEX HEAD	1
3	86017	COUPLING, MORFLEX 402 CENTER	1
4	86309	MOUNTING DISC, FLEXIBLE HEAD	1
5	86343	BUSHING, RUBBER 1-1/4 X 3/4 X 3/8	4
6	10030	SCREW, CAP 3/8-24 X 2 (USE RED LOCTITE)	2
7	10336	SCREW, CAP 3/8-24 X 2-1/4	2
8	10811	WASHER, LOCK 3/8 ZINC	2
9	10025	WASHER, FLAT 3/8 SAE ZINC	2
10	10004	NUT, HEX LOCK 3/8-24 ZINC	3

ILLUSTRATION 8: GASOLINE ENGINE & BELT DRIVE GROUPING

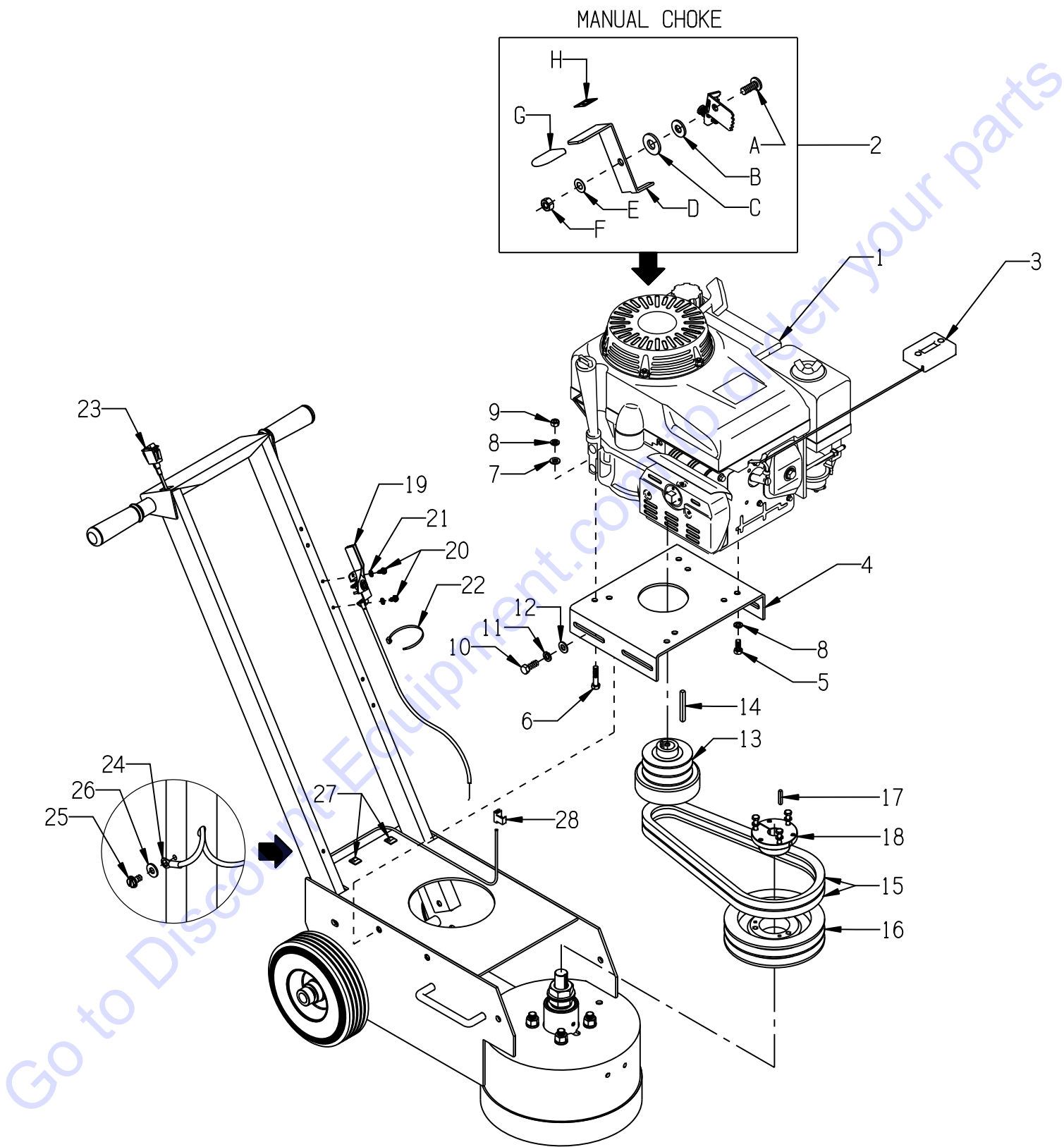

PARTS LISTING - ILLUSTRATION 8: GASOLINE ENGINE & BELT DRIVE GROUPING

ITEM #	PART #	DESCRIPTION	QTY.
1	76004	ENGINE, HONDA MODEL GXV340UT2-DX3	1
2	15190	MANUAL CHOKE KIT FOR HONDA GXV340	1
2-A	15185	SCREW, MACHINE M6 X 16MM PHILLIP HD	1
2-B	15188	WASHER .265"ID, .50"OD, .029-.035"THK	1
2-C	15187	WASHER, FIBER .75 X .25 X .093	1
2-D	15183	LEVER, CHOKE CONTROL, GXV340	1
2-E	15186	WASHER, BELLEVILLE .500 X.255 X.018	1
2-F	28026	NUT, HEX NYLON LOCK M6 X 1MM	1
2-G	15184	CAP, FLAT RED .062 X .75 X 1	1
2-H	91301	DECAL, CHOKE 5/8 X 5/8	1
3	15138	HOUR METER, INDUCTIVE (OPTIONAL)	1
4	86311	MOUNT, ENGINE	1
5	10048	SCREW, CAP 5/16-24 X 3/4	2
6	10342	SCREW, CAP 5/16-18 X 1-1/2	2
7	10213	WASHER, FLAT 5/16 SAE ZINC	2
8	10801	WASHER, LOCK 5/16 ZINC	4
9	10054	NUT, HEX 5/16-18 ZINC	2
10	10055	SCREW, CAP 3/8-16 X 1	4
11	10811	WASHER, LOCK 3/8 ZINC	4
12	10025	WASHER, FLAT 3/8 SAE ZINC	4
13	76024	CLUTCH, CENTRIFUGAL 3.5 X 2GR X 1	1
14	10071	KEY 1/4SQ X 2-1/2	1
15	10290	BELT B-35	2
16	75010	SHEAVE 6.9"OD X 2GR.B X SDS	1
17	50523	KEY 3/16SQ X 1-1/8	1
18	10081M	BUSHING, SHEAVE SDS X 7/8 MODIFIED COUNTER BORED 1-3/4"DIA. X 3/8"DEEP	1
19	40388	CABLE, THROTTLE, LEVER-TYPE 24"	1
20	10877	SCREW, CAP STSHW 10-24 X 1/2	2
21	10831	WASHER, LOCK, INT. TOOTH #10	2
22	10982	TIE, CABLE, BLACK NYLON 11-1/4"	1
23	15201A	SWITCH W/ WIRES, ROCKER RED ON-OFF	1
24	50084	TERM., RING #10 16-14GA. INSULATED	1
25	10831	WASHER, LOCK, INT. TOOTH #10	1
26	10877	SCREW, CAP STSHW 10-24 X 1/2	1
27	36042	CLIP, NATURAL CORD, 1/8" X 1/4"	3
28	10970	CONN., WIRE QUICK-SPLICE 18-14 GA.	1



A Division of Equipment Development Company, Inc.

Printed in USA

JWA ©2012

Page 13

ILLUSTRATION 9: PROPANE ENGINE & BELT DRIVE GROUPING

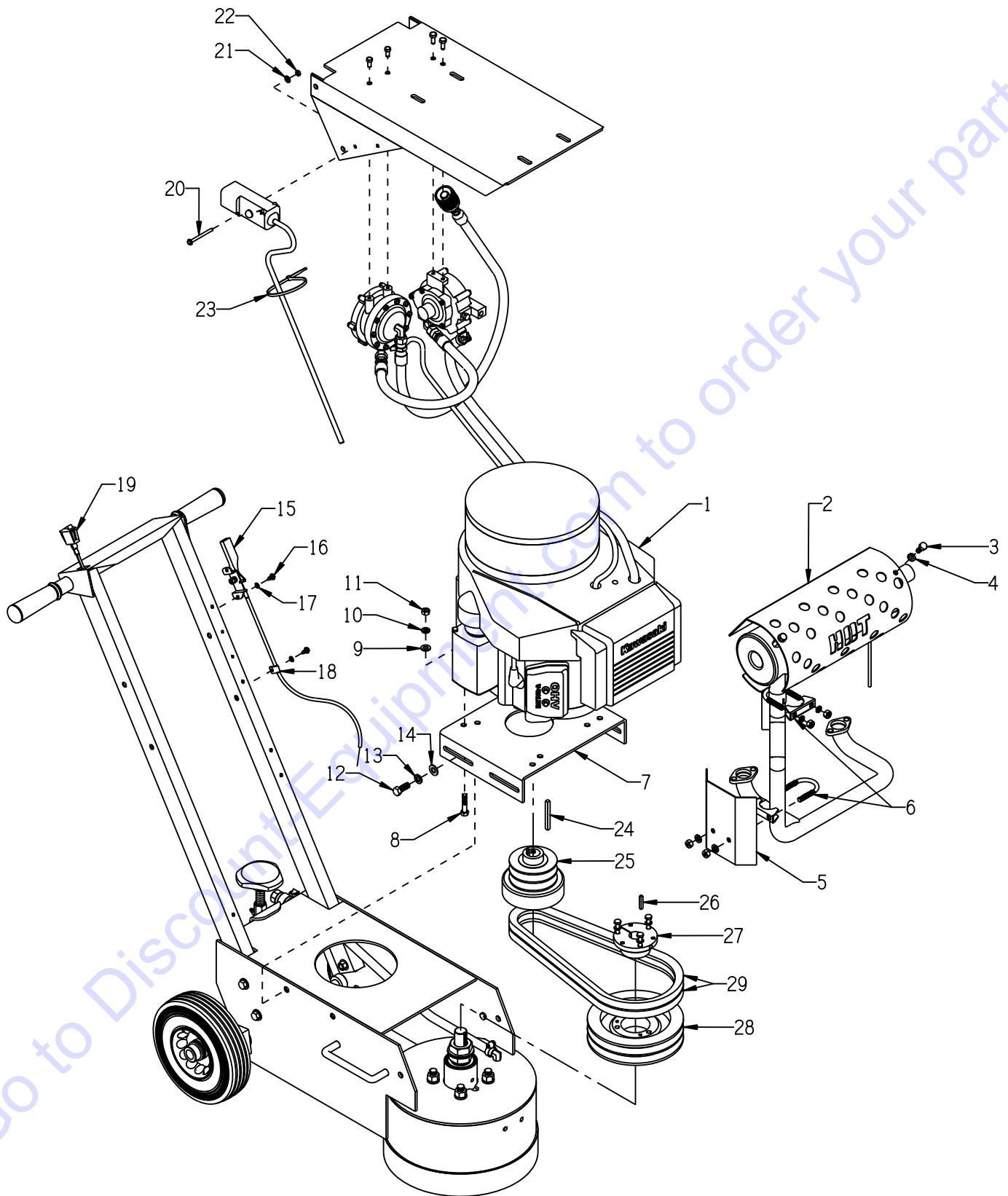

PARTS LISTING - ILLUSTRATION 9 : PROPANE ENGINE & BELT DRIVE GROUPING

ITEM #	PART #	DESCRIPTION	QTY.
1	15083	ENGINE, KAWASAKI FH381V PROP. READY 13HP INCLUDES: 110V STARTER, OIL PRESSURE SWITCH, OIL DRAIN, CATALYTIC MUFFLER AND EXHAUST MANIFOLD LP FUEL SYSTEM: REGULATOR, VACUUM LOCKOFF, HIGH & LOW PRESSURE HOSES, & REGO TANK CONNECTOR.	1
2	86372	HEAT SHIELD, MUFFLER, KAW. FH381V	1
3	10053	SCREW, CAP 5/16-18 X 3/4	2
4	10801	WASHER, LOCK 5/16 ZINC	2
5	86373	HEAT SHIELD, SIDE MANIFOLD, KAW. FH381V	1
6	86374	CLAMP, EXHAUST 5/16 X 1-1/4	2
7	86311	MOUNT, ENGINE/MOTOR	1
8	10342	SCREW, CAP 5/16-18 X 1-1/2	4
9	10213	WASHER, FLAT 5/16 SAE ZINC	4
10	10801	WASHER, LOCK 5/16 ZINC	4
11	10054	NUT, HEX 5/16-18 ZINC	4
12	10055	SCREW, CAP 3/8-16 X 1	4
13	10811	WASHER, LOCK 3/8 ZINC	4
14	10025	WASHER, FLAT 3/8 SAE ZINC	4
15	3611	CABLE, THROTTLE, LEVER-TYPE 54"	1
16	10877	SCREW, CAP STSHW 10-24 X 1/2	4
17	10831	WASHER, LOCK, INT. TOOTH #10	4
18	10941	CLIP, CONDUIT, THROTTLE CABLE	2
19	15201A	SWITCH W/ WIRES, ROCKER RED ON-OFF ADDITIONAL PARTS REQ'D. (NOT SHOWN):	1
	50084	TERM., RING #10 16-14GA. INSULATED	1
	10831	WASHER, LOCK, INT. TOOTH #10	1
	10877	SCREW, CAP STSHW 10-24 X 1/2	1
	11567	CONNECTOR, BULLET STD. 16-14GA.BLUE	1
	36042	CLIP, NATURAL CORD, 1/8" X 1/4"	3
20	11739	SCREW, MACHINE 10-24 X 2.25 HWHSLMS	2
21	10850	WASHER, FLAT #10 SAE ZINC	2
22	11740	NUT, KEPS LOCK 10-24 ZINC	2
23	10982	TIE, CABLE, BLACK NYLON 11-1/4"	2
24	10071	KEY 1/4SQ X 2-1/2	1
25	76024	CLUTCH, CENTRIFUGAL 3.5 X 2GR X 1	1
26	50523	KEY 3/16SQ X 1-1/8	1
27	10081M	BUSHING, SHEAVE SDS X 7/8 MODIFIED COUNTER BORED 1-3/4"DIA. X 3/8"DEEP	1
28	75010	SHEAVE 6.9"OD X 2GR.B X SDS	1
29	10290	BELT B-35	2



A Division of Equipment Development Company, Inc.

Printed in USA

JWA ©2012

Page 15

ILLUSTRATION 10: PROPANE TANK GROUPING

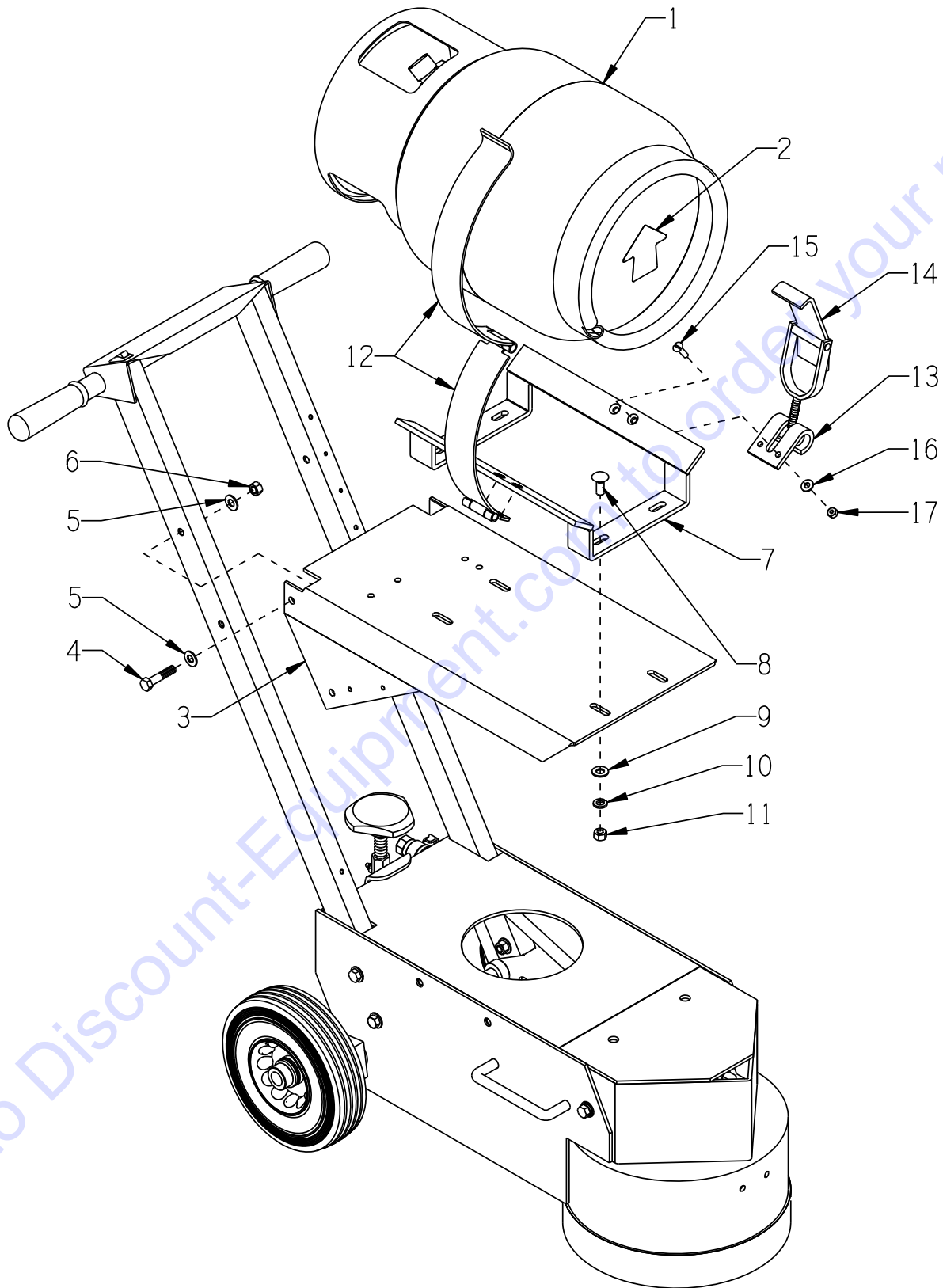

PARTS LISTING
ILLUSTRATION 10: PROPANE TANK GROUPING

ITEM #	PART #	DESCRIPTION	QTY.
1	15130	PROPANE TANK 20LB. HORZ./VERT.	1
2	91122	DECAL, ARROW, RED, 3 X 3	1
3	86327	MOUNT, PROPANE TANK, TG-10	1
4	10029	SCREW, CAP 3/8-24 X 1-3/4	4
5	10025	WASHER, FLAT 3/8 SAE ZINC	8
6	10004	NUT, HEX LOCK 3/8-24 ZINC	4
7	77061-1	PROPANE TANK CRADLE BRACKET ONLY	1
8	10802	BOLT, CARRIAGE 3/8-16 X 1 ZINC	4
9	10025	WASHER, FLAT 3/8 SAE ZINC	4
10	10811	WASHER, LOCK 3/8 ZINC	4
11	10404	NUT, HEX 3/8-16 ZINC	4
12	77061-2	PROPANE TANK STRAP W/ HINGE	1
13	77061-3	PROPANE TANK CLAW BRACKET	1
14	77061-4	PROPANE TANK TOGGLE CLAMP	1
15	11661	SCREW, FLAT HD SLT 1/4-20 X 1	4
16	10602	WASHER, FLAT 1/4 SAE ZINC	4
17	10861	NUT, KEPS LOCK 1/4-20 ZINC	4



A Division of Equipment Development Company, Inc.

ILLUSTRATION 11:
SINGLE PHASE MOTOR
& BELT DRIVE GROUPING

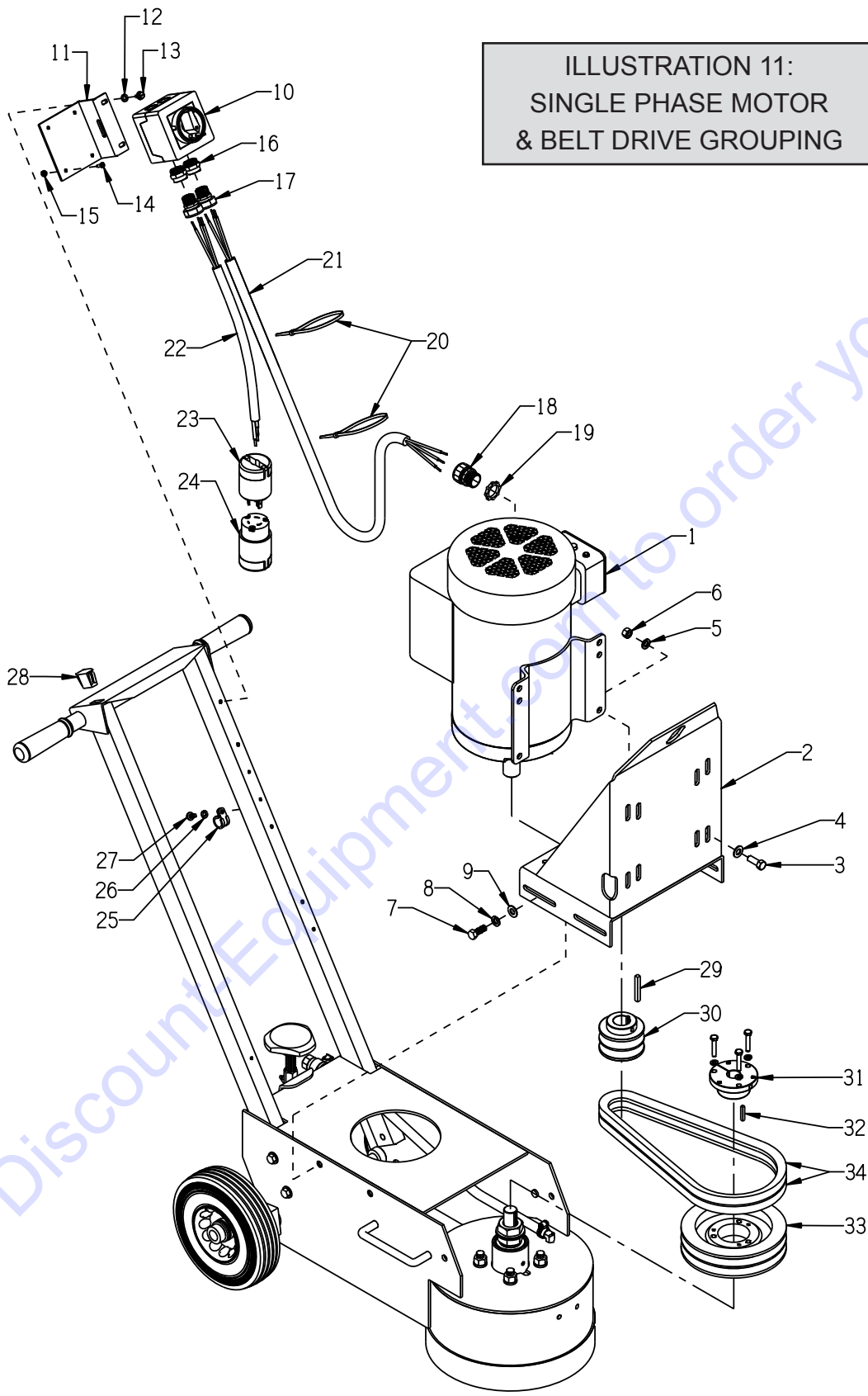

PARTS LISTING - ILLUSTRATION 11: 1-PHASE MOTOR & BELT DRIVE GROUPING			
ITEM #	PART #	DESCRIPTION	QTY.
1	81026	MOTOR, BALDOR 5HP-1PH 60HZ 3450RPM	1
		REPLACEMENT PARTS:	
	16121	CAPACITOR, START, BALDOR EC1161C06SP	2
	16164	CAPACITOR, RUN, BALDOR #OC3040F09SP	1
	16540	THERMAL PROT. (RESET BUTTON) TPBRT25DB	1
2	86404	MOUNT, MOTOR	1
3	10021	SCREW, CAP 3/8-24 X 1	4
4	10025	WASHER, FLAT 3/8 SAE ZINC	4
5	10811	WASHER, LOCK 3/8 ZINC	4
6	10014	NUT, HEX 3/8-24 ZINC	4
7	10055	SCREW, CAP 3/8-16 X 1	4
8	10811	WASHER, LOCK 3/8 ZINC	4
9	10025	WASHER, FLAT 3/8 SAE ZINC	4
10	77043	SWITCH, ROTARY CAM ON/OFF	1
11	77042	BRACKET, ROTARY CAM SWITCH	1
12	10846	SCREW, CAP STSHW 1/4-20 X 1/2	2
13	10038	WASHER, LOCK 1/4 ZINC	2
14	11663	SCREW, MACHINE 8-32 X 1/2 (LOCATED INSIDE OF SWITCH BOX)	4
15	10462	NUT, KEPS LOCK 8-32 ZINC	4
16	77043-1	SWITCH ADAPTER, PG16 TO 1/2"NPT	2
17	41130	STRAIN RELIEF 1/2NPT X .550-.650"	2
18	10959	STRAIN RELIEF 3/4 NPT X .550-.650"	1
19	10740	CONDUIT LOCK NUT 3/4 NP (LOCATED INSIDE JUNCTION BOX)	1
20	10982	TIE, CABLE, BLACK NYLON 11-1/4"	2
21	86331	WIRE HARNESS 10/3 X 50"LOA, TG-10	1
22	86026	WIRE HARNESS 10/3 X 24"LOA	1
23	40037	PLUG, LOCKING 20A/250V L6-20P	1
24	40000	CONNECTOR, LOCKING 20A/250V L6-20C	1
25	11565	CLAMP, LOOM, 5/8" (SAE SIZE 10)	1
26	10831	WASHER, LOCK, INT. TOOTH #10	1
27	10877	SCREW, CAP STSHW 10-24 X 1/2	1
28	15204	PLUG, RECT. HOLE, PLASTIC SNAP-IN	1
29	----	KEY 1/4SQ X 1-3/4 (COMES WITH MOTOR)	1
30	79023	SHEAVE 3"OD X 2GR.B X 1-1/8"BORE	1
31	10081M	BUSHING, SHEAVE SDS X 7/8 MODIFIED COUNTER BORED 1-3/4"DIA. X 3/8"DEEP	1
32	50523	KEY 3/16SQ X 1-1/8	1
33	75010	SHEAVE 6.9"OD X 2GR.B X SDS	1
34	10290	BELT B-35	1



A Division of Equipment Development Company, Inc.

Printed in USA

JWA ©2012

Page 19

ILLUSTRATION 12:
THREE-PHASE MOTOR
& BELT DRIVE GROUPING

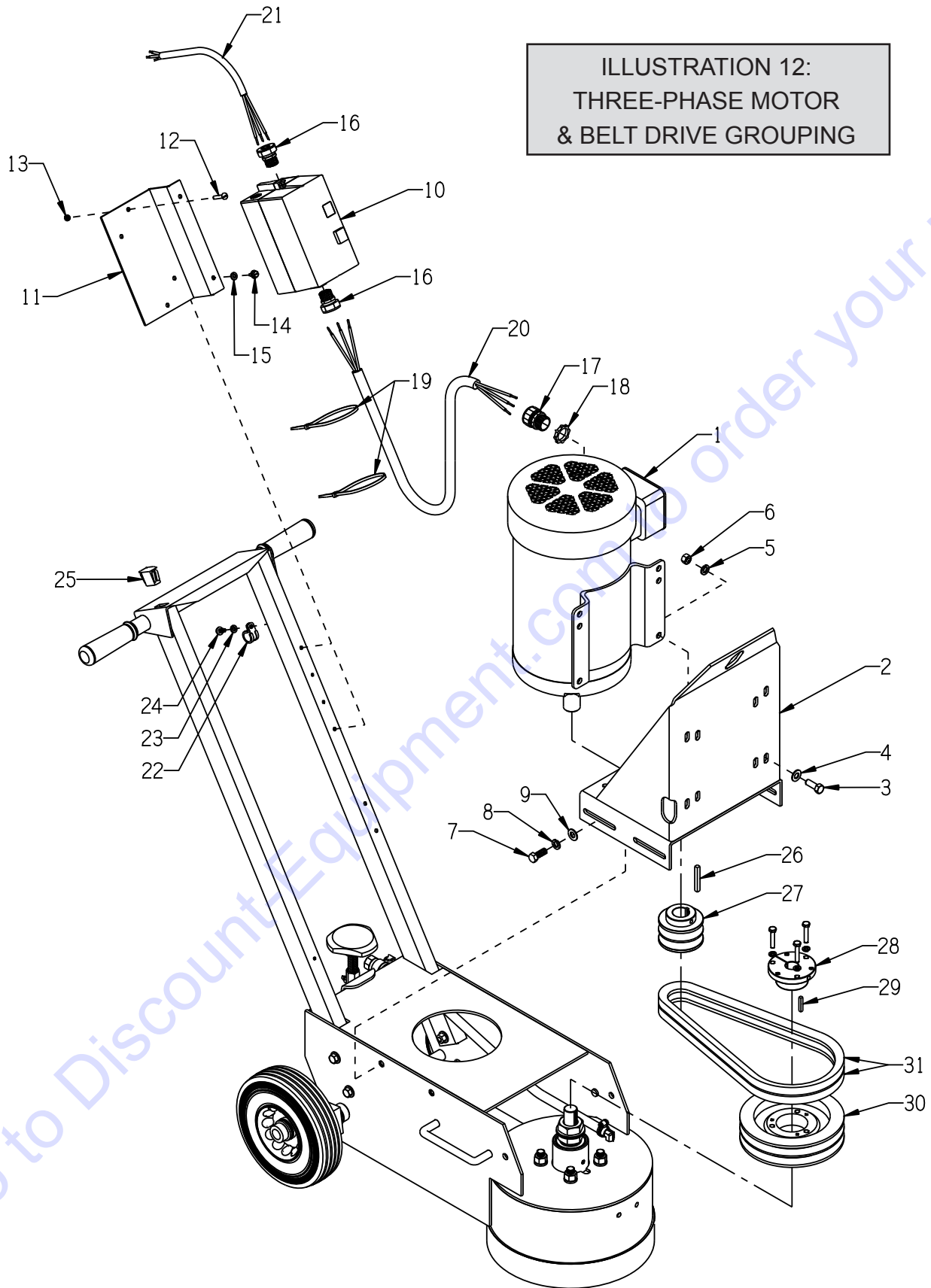

PARTS LISTING - ILLUSTRATION 12: THREE-PHASE MOTOR & BELT DRIVE GROUPING			
ITEM #	PART #	DESCRIPTION	QTY.
1	81022	MOTOR, BALDOR 5HP-3PH 60HZ 3450RPM CAT. NO. EM3613T	1
	16020	MOTOR, BALDOR 5HP-3PH 50HZ 2850RPM CAT. NO. M3613T-50	1
2	86404	MOUNT, MOTOR	1
3	10021	SCREW, CAP 3/8-24 X 1	4
4	10025	WASHER, FLAT 3/8 SAE ZINC	4
5	10811	WASHER, LOCK 3/8 ZINC	4
6	10014	NUT, HEX 3/8-24 ZINC	4
7	10055	SCREW, CAP 3/8-16 X 1	4
8	10811	WASHER, LOCK 3/8 ZINC	4
9	10025	WASHER, FLAT 3/8 SAE ZINC	4
10	16405	STARTER ACI #128841 START-STOP 200/240V COIL 11.3-16A O/L	1
	16406	STARTER ACI 440/480V COIL 5.5-7.5A O/L	1
	16482	STARTER ACI 440/480V COIL 7.2-10A O/L (USED FOR 50HZ-380V)	1
		REPLACEMENT PARTS:	
	16617	STARTER CONT./COIL ACI SK18.310-230	1
	16618	STARTER CONT./COIL ACI SK18.310-460	1
	16622	STARTER AC COIL 200/240V-60HZ, 190/220-50HZ	1
	16623	STARTER AC COIL 440/480V-60HZ, 380/415-50HZ	1
	16632	STARTER OVERLOAD RELAY 5.5-7.5 AMP	1
	16633	STARTER OVERLOAD RELAY 7.2-10.0 AMP	1
16635	STARTER OVERLOAD RELAY 11.3-16.0 AMP	1	
11	86027	MOUNTING BRKT., STARTER	1
12	11732	SCREW, MACHINE 10-32 X 1-3/4 RPH	2
	10384	SCREW, MACHINE 10-32 X 1 RHP	1
13	10832	NUT, KEPS LOCK 10-32 ZINC	2
14	10846	SCREW, CAP STSHW 1/4-20 X 1/2	2
15	10038	WASHER, LOCK 1/4 ZINC	2
16	41053	STRAIN RELIEF 1/2NPT X .625-.750"	2
17	10605	STRAIN RELIEF 3/4NPT X .650-.750"	1
18	10740	CONDUIT LOCK NUT 3/4 NP (LOCATED INSIDE OF JUNCTION BOX)	1
19	10982	TIE, CABLE, BLACK NYLON 11-1/4"	2
20	86332	WIRE HARNESS 12/4 X 42"LOA, TG-10	1
21	86022	WIRE HARNESS 12/4 X 26"LOA	1
22	11565	CLAMP, LOOM, 5/8" (SAE SIZE 10)	1
23	10831	WASHER, LOCK, INT. TOOTH #10	1
24	10877	SCREW, CAP STSHW 10-24 X 1/2	1
25	15204	PLUG, RECT. HOLE, PLASTIC SNAP-IN	1
26	-----	KEY 1/4SQ X 1-3/4 (COMES WITH MOTOR)	1
27	79023	SHEAVE 3"OD X 2GR.B X 1-1/8"BORE	1
28	10081M	BUSHING, SHEAVE SDS X 7/8 MODIFIED (60Hz MOTOR ONLY) COUNTER BORED 1-3/4"DIA. X 3/8"DEEP	1
29	50523	KEY 3/16SQ X 1-1/8	1
30	75010	SHEAVE 6.9"OD X 2GR.B X SDS (60Hz MOTOR)	1
	86344	SHEAVE 4.55"OD X 2GR.B X 7/8"BORE (50Hz MOTOR)	1
31	10290	BELT B-35 (60Hz MOTOR)	2
	10035	BELT 5L-330 (50Hz MOTOR)	2



A Division of Equipment Development Company, Inc.

WIRING DIAGRAM FOR ROTARY CAM SWITCH (SINGLE PHASE)

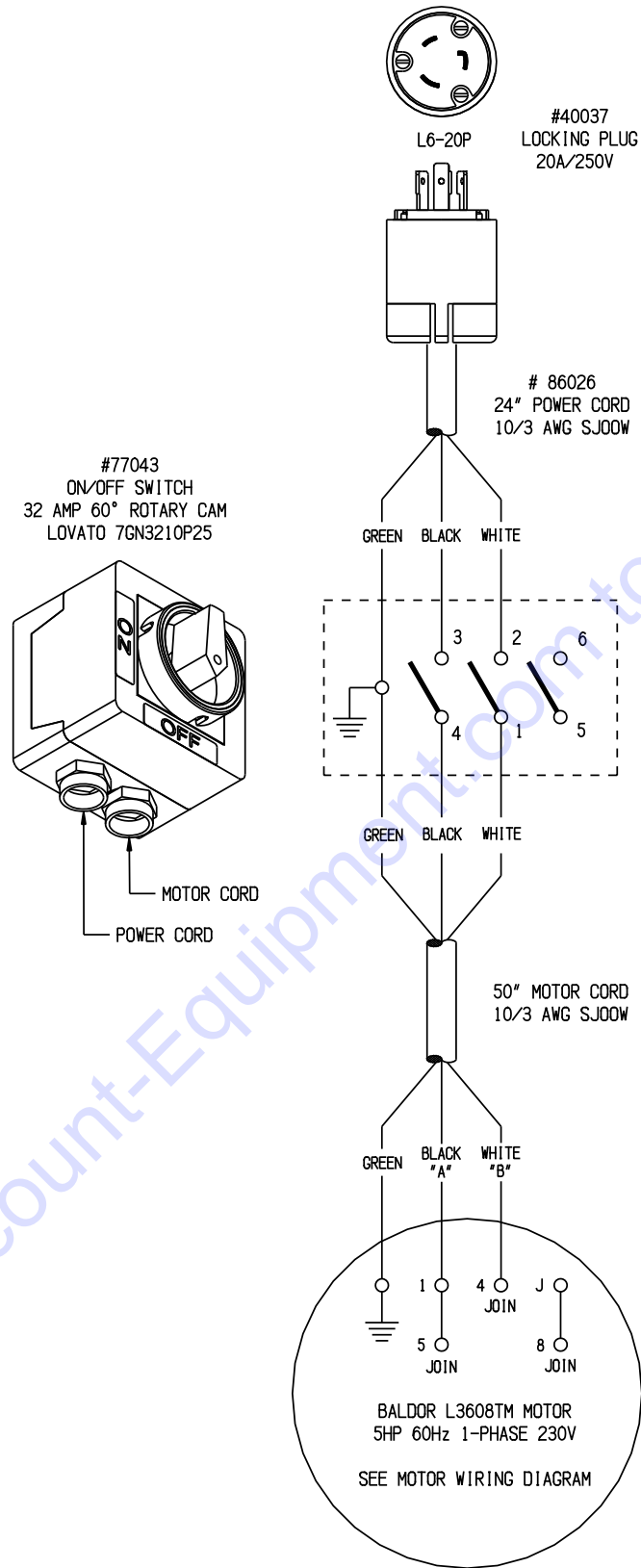

Go to Discount-Equipment.com to order your parts

WIRING DIAGRAM FOR STARTER (THREE PHASE)

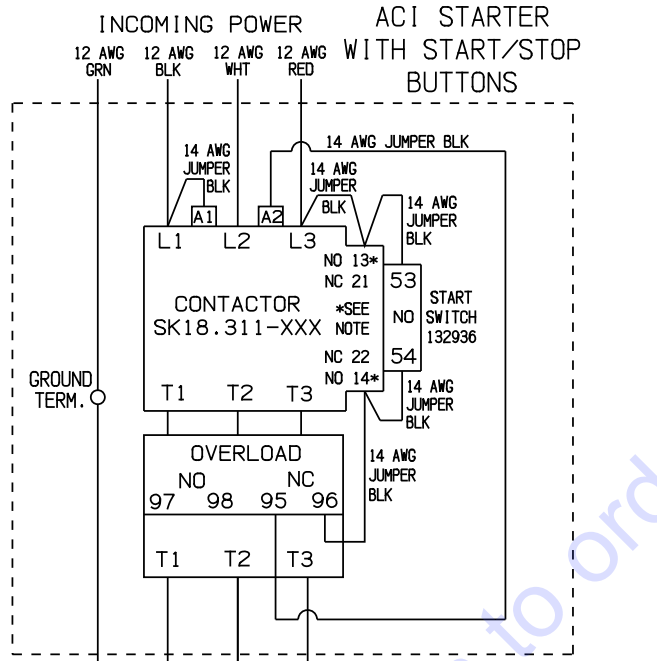

*NOTE:
TERMINALS 21 & 22 ARE LOCATED
ON THE TOP. BE SURE THE JUMPER
WIRES ARE CONNECTED TO TERMINALS
13 & 14 WHICH ARE BELOW 21 & 22.

COLOR CODES	
BLK	= BLACK
GRN	= GREEN
RED	= RED
WHT	= WHITE

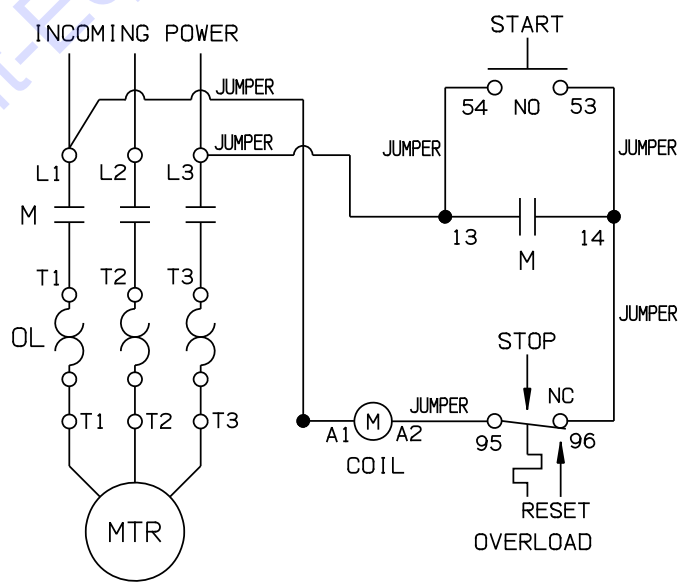

MOTOR WIRING DIAGRAM 1-PHASE 60 Hz 230V

USE CONNECTIONS FOR OPPOSITE ROTATION (CLOCK-WISE) SHOWN BELOW
 LINE A = BLACK WIRE, LINE B = WHITE WIRE

CD0002A02

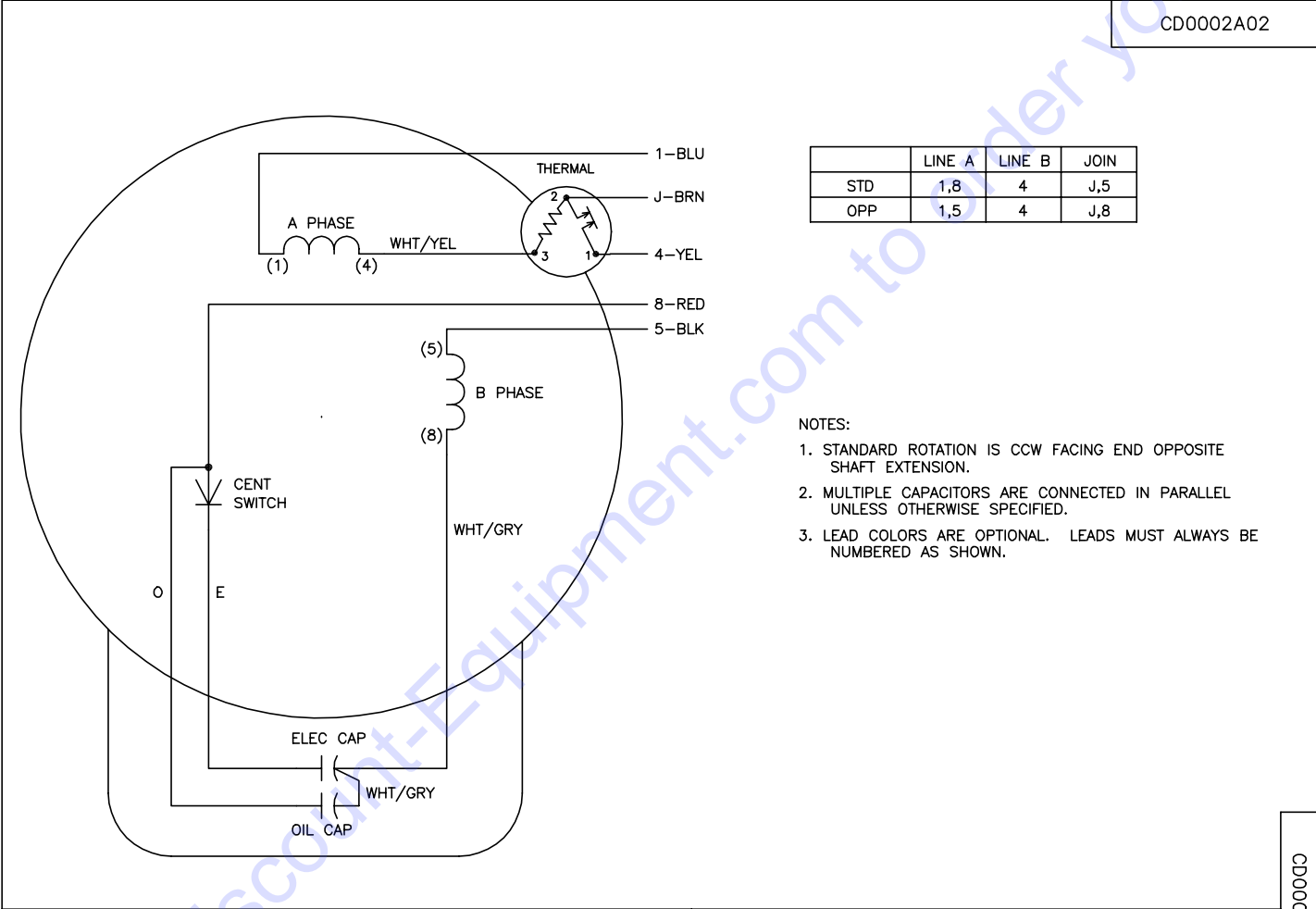

- NOTES:
1. STANDARD ROTATION IS CCW FACING END OPPOSITE SHAFT EXTENSION.
 2. MULTIPLE CAPACITORS ARE CONNECTED IN PARALLEL UNLESS OTHERWISE SPECIFIED.
 3. LEAD COLORS ARE OPTIONAL. LEADS MUST ALWAYS BE NUMBERED AS SHOWN.

CD0002A02

REV. DESC: REMOVE 2-TERMINAL THERMAL DETAIL, SEE CD0002A04		
REV. LTR: D	VERSION: 01	TDR: 000000360649
Z0VZ000D0	FILE: \AAA\00007\520	REVISED: 17:11:40 04/15/2005
	MTL: -	BY: ENJOEPO

BALDOR ELECTRIC Co.

TYPE LC, SV, REV, THERMAL, 5 LEADS



MOTOR WIRING DIAGRAM 3-PHASE 60 Hz 230/460V

CD0005

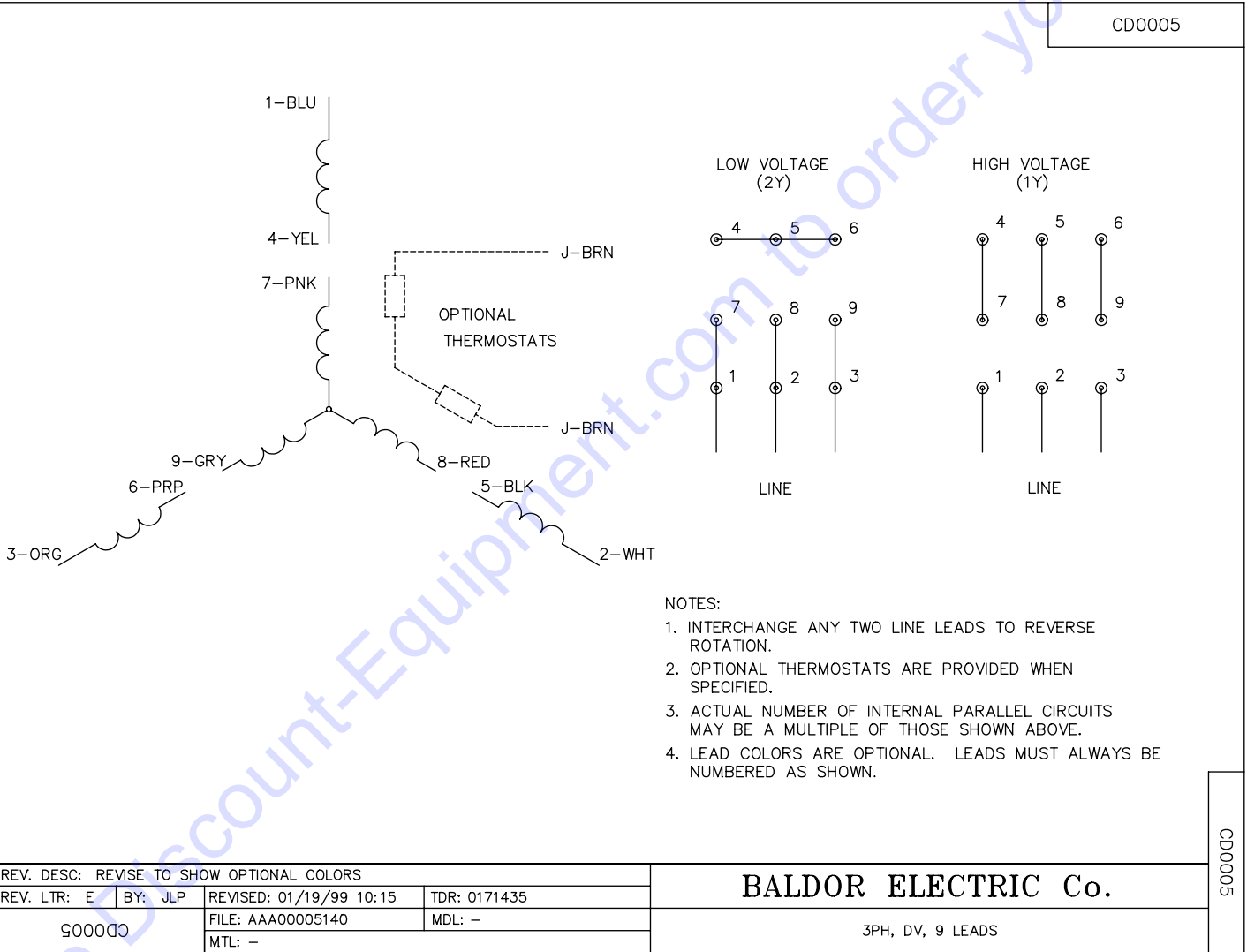

- NOTES:
1. INTERCHANGE ANY TWO LINE LEADS TO REVERSE ROTATION.
 2. OPTIONAL THERMOSTATS ARE PROVIDED WHEN SPECIFIED.
 3. ACTUAL NUMBER OF INTERNAL PARALLEL CIRCUITS MAY BE A MULTIPLE OF THOSE SHOWN ABOVE.
 4. LEAD COLORS ARE OPTIONAL. LEADS MUST ALWAYS BE NUMBERED AS SHOWN.

REV. DESC: REVISE TO SHOW OPTIONAL COLORS			
REV. LTR: E	BY: JLP	REVISED: 01/19/99 10:15	TDR: 0171435
S00000		FILE: AAA00005140	MDL: -
		MTL: -	

BALDOR ELECTRIC Co.

3PH, DV, 9 LEADS

CD0005



A Division of Equipment Development Company, Inc.

Printed in USA

JWA ©2012

Page 25

MOTOR WIRING DIAGRAM 3-PHASE 50 Hz 220/380/440V

CD0044

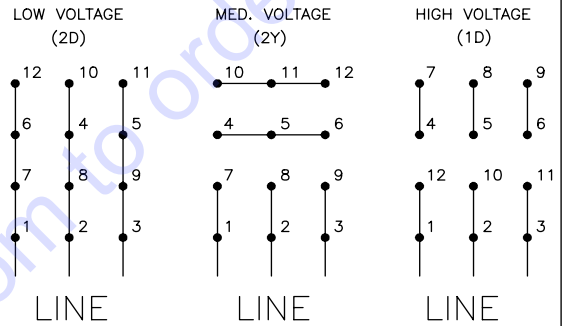
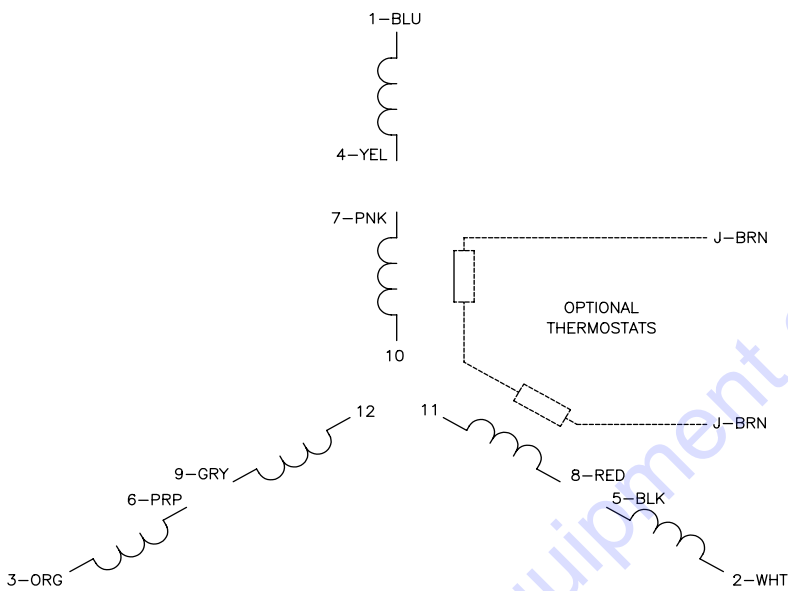

NOTES:

1. INTERCHANGE ANY TWO LINE LEADS TO REVERSE ROTATION.
2. OPTIONAL THERMOSTATS ARE PROVIDED WHEN SPECIFIED.
3. ACTUAL NUMBER OF INTERNAL PARALLEL CIRCUITS MAY BE A MULTIPLE OF THOSE SHOWN ABOVE.
4. LEAD COLORS ARE OPTIONAL. LEADS MUST ALWAYS BE NUMBERED AS SHOWN.

CD0044

REV. DESC: REVISE TO SHOW OPTIONAL COLORS			
REV. LTR: G	BY: JLP	REVISED: 01/19/99 4:09	TDR: 0171435
CD0044		FILE: AAA00008373	MDL: -
		MTL: -	

BALDOR ELECTRIC Co.

3PH, TV, 12 LEADS, 2D/2Y/1D



PARTS FINDER

**Search Website
by Part Number**



**Search Manual
Library For Parts
Manual & Lookup Part
Numbers – Purchase
or Request Quote**

Search Manuals

Enter your information to help us find the right parts manual for your machine.

* Brand:

* Model:

* Serial:

* Part Number:

SEARCH

**Can't Find Part or
Manual? Request Help
by Manufacturer,
Model & Description**

Parts Order Form

Please fill in the following information to help us find the right part for your machine.

Manufacturer:	<input type="text"/>
Model:	<input type="text"/>
Description:	<input type="text"/>
Part Number:	<input type="text"/>
Quantity:	<input type="text"/>
Notes:	<input type="text"/>

Submit

Discount-Equipment.com is your online resource for quality parts & equipment.

Florida: **561-964-4949** Outside Florida TOLL FREE: **877-690-3101**

Need parts?

Click on this link: <http://www.discount-equipment.com/category/5443-parts/> and choose one of the options to help get the right parts and equipment you are looking for. Please have the machine model and serial number available in order to help us get you the correct parts. If you don't find the part on the website or on one of the online manuals, please fill out the request form and one of our experienced staff members will get back to you with a quote for the right part that your machine needs.

We sell worldwide for the brands: Genie, Terex, JLG, MultiQuip, Mikasa, Essick, Whiteman, Mayco, Toro Stone, Diamond Products, Generac Magnum, Airman, Haulotte, Barreto, Power Blanket, Nifty Lift, Atlas Copco, Chicago Pneumatic, Allmand, Miller Curber, Skyjack, Lull, Skytrak, Tsurumi, Husquvarna Target, Stow, Wacker, Sakai, Mi-T-M, Sullair, Basic, Dynapac, MBW, Weber, Bartell, Bennar Newman, Haulotte, Ditch Runner, Menegotti, Morrison, Contec, Buddy, Crown, Edco, Wyco, Bomag, Laymor, EZ Trench, Bil-Jax, F.S. Curtis, Gehl Pavers, Heli, Honda, ICS/PowerGrit, IHI, Partner, Imer, Clipper, MMD, Koshin, Rice, CH&E, General Equipment, Amida, Coleman, NAC, Gradall, Square Shooter, Kent, Stanley, Tamco, Toku, Hatz, Kohler, Robin, Wisconsin, Northrock, Oztec, Toker TK, Rol-Air, APT, Wylie, Ingersoll Rand / Doosan, Innovatech, Con X, Ammann, Mecalac, Makinex, Smith Surface Prep, Small Line, Wanco, Yanmar