

OPERATION AND PARTS MANUAL



MODEL ST2010 Series SUBMERSIBLE PUMP

Revision #3 (12/07/12)



www.discount-equipment.com

THIS MANUAL MUST ACCOMPANY THE EQUIPMENT AT ALL TIMES.

TO PURCHASE THIS PRODUCT PLEASE CONTACT US



**Equipment Financing and
Extended Warranties Available**



**Discount-Equipment.com is your online resource for
commercial and industrial quality parts and equipment sales.**

561-964-4949

visit us on line @ www.discount-equipment.com

Select an option below to find your Equipment

Search by Manufacturer

Search by Product Type

Request a Quote

We sell worldwide for the brands: Genie, Terex, JLG, MultiQuip, Mikasa, Essick, Whiteman, Mayco, Toro Stone, Diamond Products, Generac Magnum, Airman, Haulotte, Barreto, Power Blanket, Nifty Lift, Atlas Copco, Chicago Pneumatic, Allmand, Miller Curber, Skyjack, Lull, Skytrak, Tsurumi, Husquvarna Target, Stow, Wacker, Sakai, Mi-T-M, Sullair, Basic, Dynapac, MBW, Weber, Bartell, Bennar Newman, Haulotte, Ditch Runner, Menegotti, Morrison, Contec, Buddy, Crown, Edco, Wyco, Bomag, Laymor, EZ Trench, Bil-Jax, F.S. Curtis, Gehl Pavers, Heli, Honda, ICS/PowerGrit, IHI, Partner, Imer, Clipper, MMD, Koshin, Rice, CH&E, General Equipment, Amida, Coleman, NAC, Gradall, Square Shooter, Kent, Stanley, Tamco, Toku, Hatz, Kohler, Robin, Wisconsin, Northrock, Oztec, Toker TK, Rol-Air, APT, Wylie, Ingersoll Rand / Doosan, Innovatech, Con X, Ammann, Mecalac, Makinex, Smith Surface Prep, Small Line, Wanco, Yanmar

TABLE OF CONTENTS

ST2010 Series Submersible Pump

Parts Ordering Procedures.....	3
Safety Information	4-7
Specifications	8
Dimensions.....	9
General Information.....	10
Components	11
Float Switches	12
Float Switch (Piggy-Back)	13
Float Switch (Control Box).....	14-15
Operation.....	16
Control Box Installation.....	17-18
Clean-Up	19
Maintenance	20
Troubleshooting	21
Performance Curves.....	22
Control Box Wiring Diagram	23-24
Motor Wiring Diagram.....	25
Explanation Of Code In Remarks Column.....	26
Suggested Spare Parts	27

Illustrations

ST010TCUL Pump Assy.....	28-29
ST2010, ST2010A/B, ST2010CUL Pump Assy.....	30-33
Electric Motor Assy.	34-35
Terms And Conditions Of Sale — Parts	36

NOTICE

Specifications and part numbers are subject to change without notice.

Go to Discount-Equipment.com to order your parts

SAFETY INFORMATION

Do not operate or service the equipment before reading the entire manual. Safety precautions should be followed at all times when operating this equipment. Failure to read and understand the safety messages and operating instructions could result in injury to yourself and others.



SAFETY MESSAGES

The four safety messages shown below will inform you about potential hazards that could injure you or others. The safety messages specifically address the level of exposure to the operator and are preceded by one of four words: **DANGER**, **WARNING**, **CAUTION** or **NOTICE**.

SAFETY SYMBOLS

! **DANGER**

Indicates a hazardous situation which, if not avoided, **WILL** result in **DEATH** or **SERIOUS INJURY**.

! **WARNING**

Indicates a hazardous situation which, if not avoided, **COULD** result in **DEATH** or **SERIOUS INJURY**.





! **CAUTION**

Indicates a hazardous situation which, if not avoided, **COULD** result in **MINOR** or **MODERATE INJURY**.

NOTICE

Addresses practices not related to personal injury.

Potential hazards associated with the operation of this equipment will be referenced with hazard symbols which may appear throughout this manual in conjunction with safety messages.

Symbol	Safety Hazard
	Burn hazards
	Electric shock hazards
	Rotating parts hazards
	Pressurized fluid hazards

SAFETY INFORMATION

GENERAL SAFETY

CAUTION

- **NEVER** operate this equipment without proper protective clothing, shatterproof glasses, respiratory protection, hearing protection, steel-toed boots and other protective devices required by the job or city and state regulations.



- Avoid wearing jewelry or loose fitting clothes that may snag on the controls or moving parts as this can cause serious injury.

- **NEVER** operate this equipment when not feeling well due to fatigue, illness or when under medication.



- **NEVER** operate this equipment under the influence of drugs or alcohol.



- **ALWAYS** clear the work area of any debris, tools, etc. that would constitute a hazard while the equipment is in operation.

- No one other than the operator is to be in the working area when the equipment is in operation.

- **DO NOT** use the equipment for any purpose other than its intended purposes or applications.

NOTICE

- This equipment should only be operated by trained and qualified personnel 18 years of age and older.

- Whenever necessary, replace nameplate, operation and safety decals when they become difficult read.

- Manufacturer does not assume responsibility for any accident due to equipment modifications. Unauthorized equipment modification will void all warranties.

- **NEVER** use accessories or attachments that are not recommended by Multiquip for this equipment. Damage to the equipment and/or injury to user may result.

- **ALWAYS** know the location of the nearest fire extinguisher.



- **ALWAYS** know the location of the nearest first aid kit.



- **ALWAYS** know the location of the nearest phone or **keep a phone on the job site**. Also, know the phone numbers of the nearest **ambulance, doctor** and **fire department**. This information will be invaluable in case of an emergency.



SAFETY INFORMATION

PUMP SAFETY

DANGER

- **NEVER** operate the equipment in an explosive atmosphere or near combustible materials. An explosion or fire could result causing severe **bodily harm or even death.**



WARNING

- Accidental starting can cause severe injury or death. **ALWAYS** place the ON/OFF switch in the OFF position.
- **DO NOT** place hands or fingers inside pump when pump is running.
- **NEVER** disconnect any **emergency or safety devices.** These devices are intended for operator safety. Disconnection of these devices can cause severe injury, bodily harm or even death. Disconnection of any of these devices will void all warranties.
- Risk of Electric Shock - This pump has not been investigated for use in swimming pool or marine areas.



CAUTION

- **DO NOT** restrict the flow of the discharge hose as it may cause the pump to overheat.
- Be careful of discharge hose whipping under pressure.
- **ALWAYS** check pump oil level only when pump is cool. Expansion due to heat may cause hot oil to spray from the oil plug when the oil plug is removed. The possibility of severe scalding may exist.

NOTICE

- **ALWAYS** place the pump in an upright position on a platform before using. The platform will prevent the pump from burrowing itself on soft sand or mud.
- **NEVER** operate pump on its side.
- **DO NOT** allow the pump to freeze in water.
- **NEVER** leave an open pump chamber unattended.
- **ALWAYS** keep the machine in proper running condition.
- **DO NOT** attempt to thaw out a frozen pump by using

a torch or other source of flame. Application of heat in this manner may heat the oil in the seal cavity above the critical point, causing pump damage.

- **DO NOT** pump water with a temperature greater than 104°F.
- **DO NOT** pump liquids containing acid or alkali.
- **ALWAYS** check strainer before pumping. Make sure strainer is not clogged. Remove any large objects, dirt or debris from the strainer to prevent clogging.
- **ALWAYS** use a large basket strainer when pumping water that contains large debris.
- **ALWAYS** flush pump (clean) after use when pumping water concentrated with heavy debris. It is very important to always flush the pump before turning it off to prevent clogging.
- Fix damage to machine and replace any broken parts immediately.
- **ALWAYS** store equipment properly when it is not being used. Equipment should be stored in a clean, dry location out of the reach of children and unauthorized personnel.
- **NEVER** lubricate components or attempt service on a running machine.
- **NEVER** run pump *dry*.
- **ALWAYS** allow the machine a proper amount of time to cool before servicing.
- Keep machine in proper running condition.

ELECTRICAL SAFETY

DANGER

- The electrical voltage required to operate pump can cause severe injury or even death through physical contact with live circuits. **ALWAYS** disconnect electrical power from pump before performing maintenance on pump.



WARNING

- To reduce the risk of electric shock, connect only to a circuit protected by a Ground-Fault Circuit-Interrupter (GFCI).

SAFETY INFORMATION

NOTICE

- **ALWAYS** make certain that the voltage supplied to the pump is correct. Always read the pump's nameplate to determine what the power requirements are.

Power Cord/Cable Safety

DANGER

- **NEVER** let power cords or cables **lay in water**.
- **NEVER** stand in water while AC power cord is connected to a live power source.
- **NEVER** use **damaged** or **worn** cables or cords. Inspect for cuts in the insulation.
- **NEVER** grab or touch a live power cord or cable with wet hands. The possibility exists of **electrical shock, electrocution or death**.

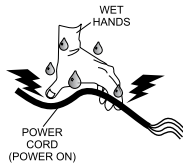

- Make sure power cables are securely connected to the motor's output receptacles. Incorrect connections may cause electrical shock and damage to the motor.

WARNING

- **NEVER** attempt to use the power cord as a lifting or lowering device for the pump.

NOTICE

- **ALWAYS** make certain that proper power or extension cord has been selected for the job. See Cable Selection Chart in this manual.

Grounding Safety

DANGER

- **ALWAYS** make sure pump is grounded.
- **NEVER** use gas piping as an electrical ground.
- **ALWAYS** make sure that electrical circuits are properly grounded to a suitable earth ground (ground rod) per the National Electrical Code (NEC) and local codes before operating generator. **Severe injury or death by electrocution** can result from operating an ungrounded motor.
- This pump is supplied with a grounding conductor and grounding-type attachment plug. To reduce the risk of electric shock, connect only to a properly grounded, grounding-type receptacle.

Control Box Safety

DANGER

- **ALWAYS** have a qualified electrician perform the control box installation. The possibility exists of electrical shock or electrocution.

NOTICE

- **ALWAYS** mount control box in a vertical position protected from harsh environmental elements.

LIFTING SAFETY

CAUTION

- When raising or lowering of the pump is required, always attach an adequate rope or lifting device to the correct lifting point (handle) on the pump.

NOTICE

- **DO NOT** lift machine to unnecessary heights.
- **NEVER** lift the equipment while the electric motor is running.

TRANSPORTING SAFETY

NOTICE

- **ALWAYS** shut down pump before transporting.
- **ALWAYS** tie down equipment during transport by securing the equipment with rope.

ENVIRONMENTAL SAFETY/DECOMMISSIONING

- **DO NOT** pour waste or oil directly onto the ground, down a drain or into any water source.
- Contact your country's Department of Public Works or recycling agency in your area and arrange for proper disposal of any electrical components, waste or oil associated with this equipment.
- When the life cycle of this equipment is over it is recommended that the pump casing and all other metal parts be sent to a recycling center.



Metal recycling involves the collection of metal from discarded products and its transformation into raw materials to use in manufacturing a new product.

Recyclers and manufacturers alike promote the process of recycling metal. Using a metal recycling center promotes energy cost savings.

SPECIFICATIONS

Table 1. Specifications

Model	ST-2010/ST-2010A/ ST-2010CUL	ST-2010B	ST-2010TCUL
Type	Submersible Pump	Submersible Pump	Submersible Trash Pump
Impeller	Cast Ductile Iron	Cast Ductile Iron	Cast Ductile Iron
Discharge Size	2.00 in. (51 mm)	2.00 in. (51 mm)	2.00 in. (51 mm)
Maximum Pumping Capacity	85 gallons/minute (322 liters/minute)	85 gallons/minute (322 liters/minute)	90 gallons/minute (341 liters/minute)
Max. Solids Diameter	---	---	1.00 in. (25 mm.)
Max Head	54.7 ft. (16.6 meters) ST-2010CUL: 50 ft. (15.24 m)	54.7 ft. (16.6 meters)	45 ft. (13.7 meters)
Power	1.0 HP (0.75 kw)	1.0 HP (0.75 kw)	1.0 HP (0.75 kw)
Voltage; Phase	1Ø 115V	1Ø 230V	1Ø 115V
Starting Amps	63 A	30 A	53 A
Running Amps	ST2010: 13.5 A ST2010A: 13.5 A ST2010CUL: 11.9A	6.7 A	9.4 A
Control Box (see Note 3)	CB3	CB6	CB3
Thermal Overload Protection	YES	YES	YES
Rotation	CCW (Note 1)	CCW (Note 1)	CCW (Note 1)
Mechanical Oil seal Capacity	150 cc. (Note 2)	150 cc. (Note 2)	180 cc. (Note 2)
Check Frequency	Monthly (300 hrs.)	Monthly (300 hrs.)	Monthly (300 hrs.)
RMP (Speed)	3550 +/- 30	3550 +/- 30	3550 +/- 30
Power Cable Length	50 ft. (15.2 meters)	50 ft. (15.2 meters)	50 ft. (15.2 meters)
Dry Net weight	55 lbs. (25 Kg.)	55 lbs. (25 Kg.)	77 lbs. (35 Kg.)

1. Motor Rotation – Upon start-up, the pump "kicks" in the opposite direction of motor rotation. The correct rotation is counterclockwise (CCW) as viewed from the impeller end of the pump.
2. Mechanical Oil Seal – Use a good grade 10 weight non-detergent hydraulic oil (i.e. Shell Turbo 32 or equivalent). Fill oil cavity 75% to 85% full (allow air space for expansion).
3. Control Box - Control box (Table 2) may be required for certain pumping applications.

Table 2. Control Box Specifications

Model No.	Voltage Type	UL/CSA Listed	Thermal Overload Protection	Float Switch Capability
CB3	115 VAC, 60 Hz Single-Phase	YES	YES	YES
CB6	230 VAC, 60 Hz Single-Phase	YES	YES	YES

ST2010TCUL

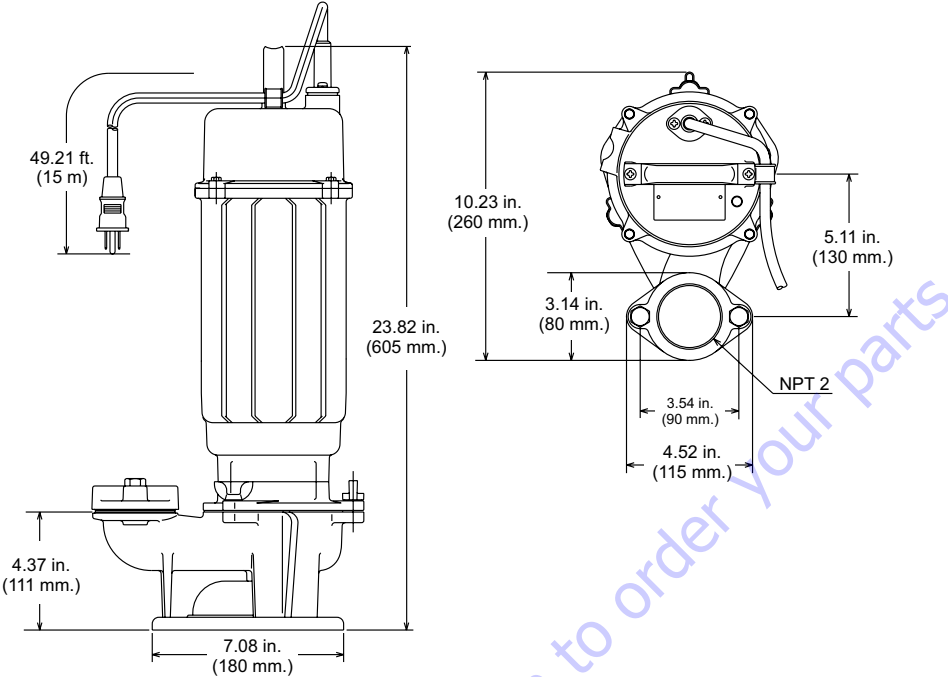

ST2010, ST2010A, ST2010B, ST2010CUL

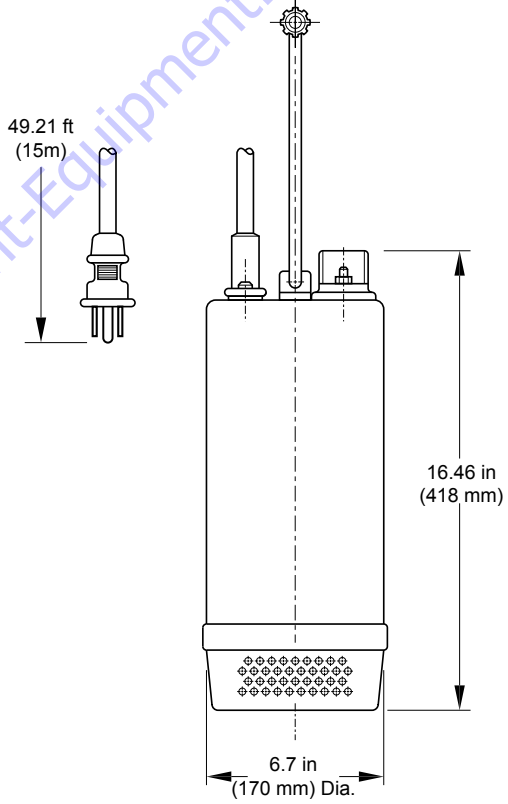

Figure 1. ST2010 Series Dimensions

GENERAL INFORMATION

INTRODUCTION

The Multiquip Model ST-2010 submersible pump is designed to pump water and is used for the draining (de-watering) of well casings construction sites, cofferdams, manholes, transformer vaults and excavations. The ST-2010TCUL is designed for heavily debris-laden water and the 2-inch discharge port can handle solids up to one inch in diameter.

A cast ductile iron type impeller is attached to the output shaft of a 1 HP electric motor which provides adequate power for general purpose pumping. This submersible pump is supplied complete with an electric power cable, and a discharge port which accepts a 2-inch hose.

This pump is ideal for portability because of its light weight and carrying handle. For reliability and long life, a mechanical seal provides shaft sealing, with an oil chamber separating the pump section from the motor.

The pump when in use, should be installed as free standing (upright position) on its strainer base. A 2-inch discharge hose (not supplied) should be connected to the discharge port. The discharge hose should be adequately supported to avoid stress on the pump.

For maximum water flow, the discharge hose should be kept as short as possible, and with minimum elevation above the pump. Remember as the length and/or height of the discharge hose is increased, the flow of water will be reduced. Also any reduction in the hose size, and any fittings such as valves or outlet nozzles, will restrict the water flow.

To avoid back-siphonage when the pump is switched off, ensure that the end of the discharge hose is installed above the water level at the final discharge point.

When the pump is switched off, the water remaining in the hose will run back through the pump. This can be avoided by placing a non-return valve in the hose nearest the pump.

NEVER use this submersible pump to pump flammable liquids or operate in a explosive or flammable environment.

Avoid using this pump in conditions where mud, grit, silt or other debris are present. These conditions could cause blockage and cause excessive pump wear.

DO NOT install the pump directly into an area where there is a heavy build-up of mud, grit, silt or debris. If this condition is present, install the pump on a platform before operating.

This pump must always be positioned on a platform in an upright position. **NEVER** operate the pump by a suspended rope. To prevent large solids from entering the pump, install a wire mesh screen or similar barrier around the pump.

If the pump was used to pump water containing mud, silt, use clean water to flush out the pump after each use.

DO NOT allow the pump to run dry, as this will damage the pump. During maintenance, dry running is permissible but only for a few seconds.

NEVER lift the pump by its electrical power cord. **ALWAYS** lift the pump by its carrying handle or attach a rope to the carrying handle.

A pump fully submerged in liquid will not freeze, unless the liquid freezes. **DO NOT** allow a partially submerged pump to freeze. The expansion of water freezing in the volute may crack the pump, causing expensive repairs. If there is any danger of the pump being subjected to freezing temperatures, Lift the pump from water and allow it to drain thoroughly.

If the pump jams or the pump rotor locks for any reason, disconnect the pump from the power source immediately. Allowing the pump motor to cycle ON and OFF under an overload condition can burn out the motor.

When replacement of nuts and bolts is required, use only recommended parts as referenced in the parts section of this manual. This pump uses metric threads. **DO NOT** use English measurement threads.

WARNING



Explosion or Fire Hazard exists if this pump is used with flammable liquids. **DO NOT** use this pump with flammable liquids. **DO NOT** install this pump in hazardous locations as defined by the National Electrical Code, ANSI/NFPA 70.

Failure to follow the above referenced precautions could result in serious injury or death! Replace pump cord immediately if cord becomes damaged or severed. This pump must be installed in accordance with National Electric Code ANSI/NFPA 70 so as to prevent moisture from entering or accumulating with the boxes, conduit bodies fittings, float housing or cable.

ST2010, ST2010A, ST2010B, ST2010CUL

ST2010TCUL

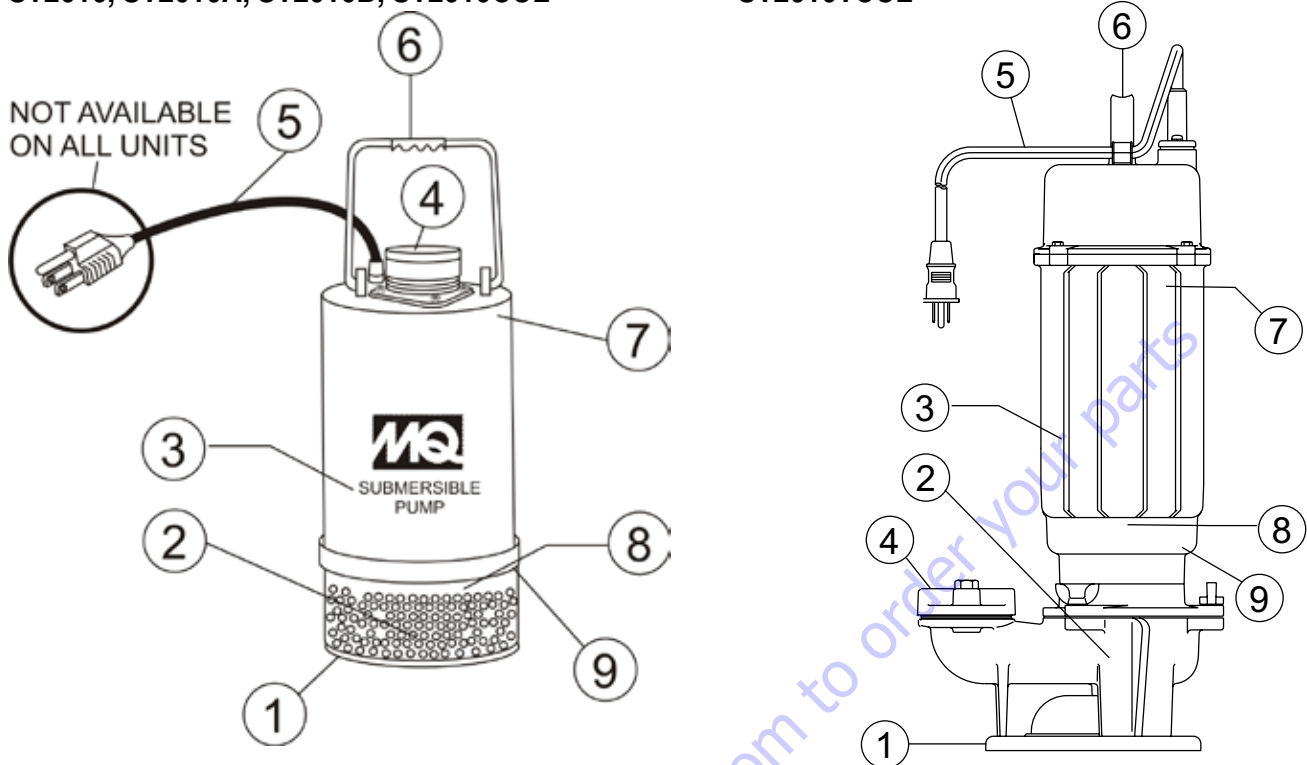

Figure 2. Submersible Pump Components

Figure 2 shows the location of the basic components for the ST2010 series submersible pumps. Listed below is a brief description of each component.

- 1. Strainer Base** — Made of chrome-plated steel which is resistant to hardware corrosion. **DO NOT** pump large objects or debris with this pump. This pump is for pumping water only. Always place the strainer base on a platform.
- 2. Volute/Impeller** — Volute is constructed of cast iron and impeller is made of cast ductile iron to minimize wear and prolong service life.
- 3. Electric Motor** — All ST2010 series submersible pumps utilize a 60 Hz, single-phase, 1.0 HP electric motor. The ST2010, ST2010A, ST2010CUL and S-2010TCUL operate at 115 VAC while the ST2010B operates at 230VAC. Consult with a licensed electrician before connecting motor to a power source. Observe all city and local safety codes.
- 4. Discharge Port** — Connect a 2-inch hose to this port. Remember to adequately support the discharge hose to avoid stress on the pump.
- 5. AC Power Cable** — This unit is supplied with an AC power cable. Always check the cable for signs of wear. **NEVER** use a defective power cable. Replace the cable immediately if the cable is worn or defective.
- 6. Carrying Handle** — Always carry the submersible pump by its handle. **NEVER** carry the pump by its power cord. Carrying or lifting the pump by the power cord will cause undue stress on the cord and ultimately the cord will become dislodged from the pump.
- 7. Thermal Overload Protection** — This pump is equipped with thermal overload protection device that will shut down the motor in the event of high operating temperatures. The motor will automatically restart once the temperature returns to an acceptable operating temperature.
- 8. Mechanical Oil Seal** — This oil-filled seal provides lubrication when running the pump dry. **NEVER** run the pump dry. Running the pump dry will cause severe damage to the pump.
- 9. Mechanical Oil Seal Plug** — Remove this plug to check and add hydraulic oil (Shell 32 or equivalent) to the oil cavity. This oil protects the mechanical seal. Oil cavity should be full enough to cover seal spring.

FLOAT SWITCHES

FLOAT SWITCH THEORY

Mercury monitoring is a mercury-switch actuated, liquid-level control that has proven to be more economical and longer lasting than other types of liquid-level control systems, easily replacing and improving upon diaphragm switches, air bubble systems and electro-mechanical switches most often relied upon in the past.

HOW IT WORKS

There is a tilt-sensitive mercury switch hermetically sealed within each float. As the liquid level (water) rises or falls, the float changes its angle until the mercury switch makes (closed, Figure 4) or breaks (open, Figure 5) the circuit. Maximum pumping range is 120 degrees. See Figure 3 below.

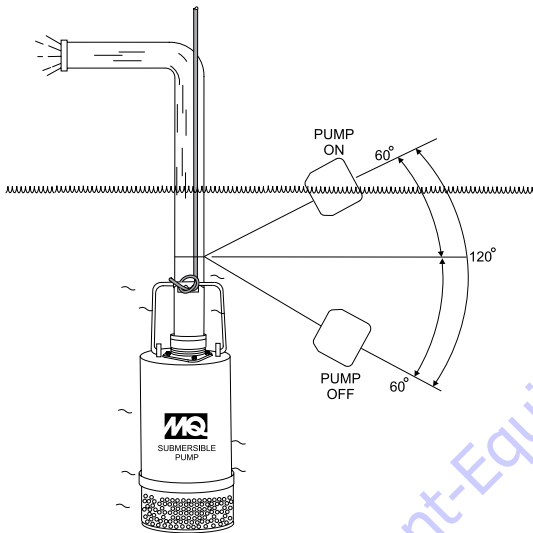

Figure 3. Pumping Range (Float Switch)

PUMPING RANGE

The pumping range of the pump is determined by the float switch tether cord. Use Table 3 as guide line to determine your required pumping range. Pumping ranges are based on non-turbulent conditions. Range may vary due to water temperature and cord shape. Please note as the tether length increases, so does the variance of the pumping range.

Table 3. Pumping Range

Tether Length	2 in. 5.08 cm.	4 in. 10.16 cm.	6 in. 15.24 cm.	8 in. 20.32 cm.	10 in. 25.4 cm.	12 in. 30.48 cm.	14 in. 35.56 cm.	16 in. 40.64 cm.
Pumping Range	6 in. 15.24 cm.	10 in. 25.4 cm.	14 in. 35.56 cm.	18 in. 45.72 cm.	22 in. 55.88 cm.	27 in. 68.58 cm.	31 in. 78.74 cm.	35 in. 88.9 cm.

DESIGN FEATURES

Constructed of rigid, durable ABS polymer ultrasonically welded. The all-steel mercury switch is held by positioning pins. Interior is filled with cell foam.

- Suitable for most liquid environments.
- Hermetically sealed.
- Thick-walled non-corrosive PVC plastic enclosure.
- Pressure tested to 60 ft. (18.2 meters).
- Mercury switch reliability, proven to 500,000 cycles.
- Standard SJO, 16-gauge, 2 conductor cord (20 ft./6.09 m).

Pump Down / ON POSITION

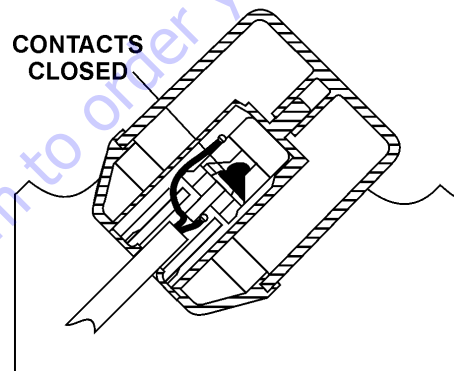

Figure 4. Float Switch (Closed)

Pump Down / OFF POSITION

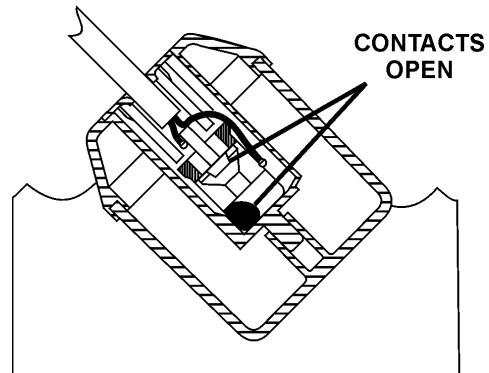

Figure 5. Float Switch (Open)

FLOAT SWITCH (PIGGY-BACK)

FLOAT SWITCH

Single or dual control float switches (Figure 6) can be used for the unattended operation of the submersible pump. When using the piggy-back power configuration (plug), the ST-2010 series pumps DO NOT require the use of a control box. In this configuration (piggy-back), the SW-1 (single float switch) or SW-2 (dual float switch) are required. The illustration below is an example of a single float switch application.

Mounting The Float Switch

1. Determine the required cord tether length as shown in Figure 6 and Table 3.

2. Place the cord into the clamp as shown in Figure 6
3. Secure the clamp to the discharge hose as shown in Figure 6. DO NOT install cord under hose clamp.
4. Using a screwdriver, tighten the hose clamp. DO NOT over-tighten. Make sure the float cord is not allowed to touch the excess hose clamp band during operation.

NOTICE

Figure 6 shows a single float switch application. For dual float switch capability use a Model SW-2 mercury type float switch.

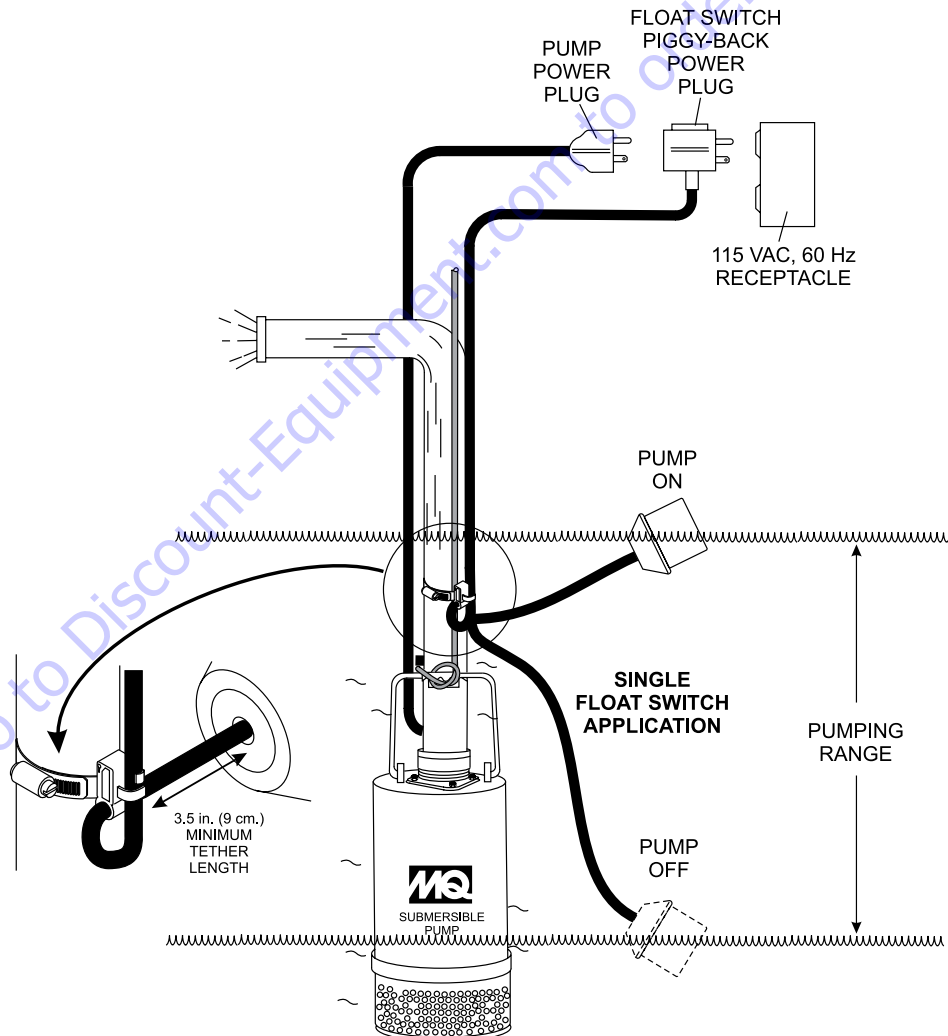

Figure 6. Single Float Switch Application Diagram

FLOAT SWITCH (CONTROL BOX)

CONTROL BOX

For special remote pumping applications of the submersible pump, a control box (Model CB3 - for ST2010, ST2010A, ST2010CUL, and ST2010TCUL and Model CB6 - for ST2010B) may be required. This water-resistant control box

provides watertight housing and glands to prevent water from leaking into the box, and a float switch interface. When using the CB3 control box, only the SW-1WOP float switch (2) can be used (no plug, bare wires).

⚠ WARNING
 INSTALLATION IS TO BE PERFORMED ONLY BY A LICENSED ELECTRICIAN OR QUALIFIED PERSONNEL.

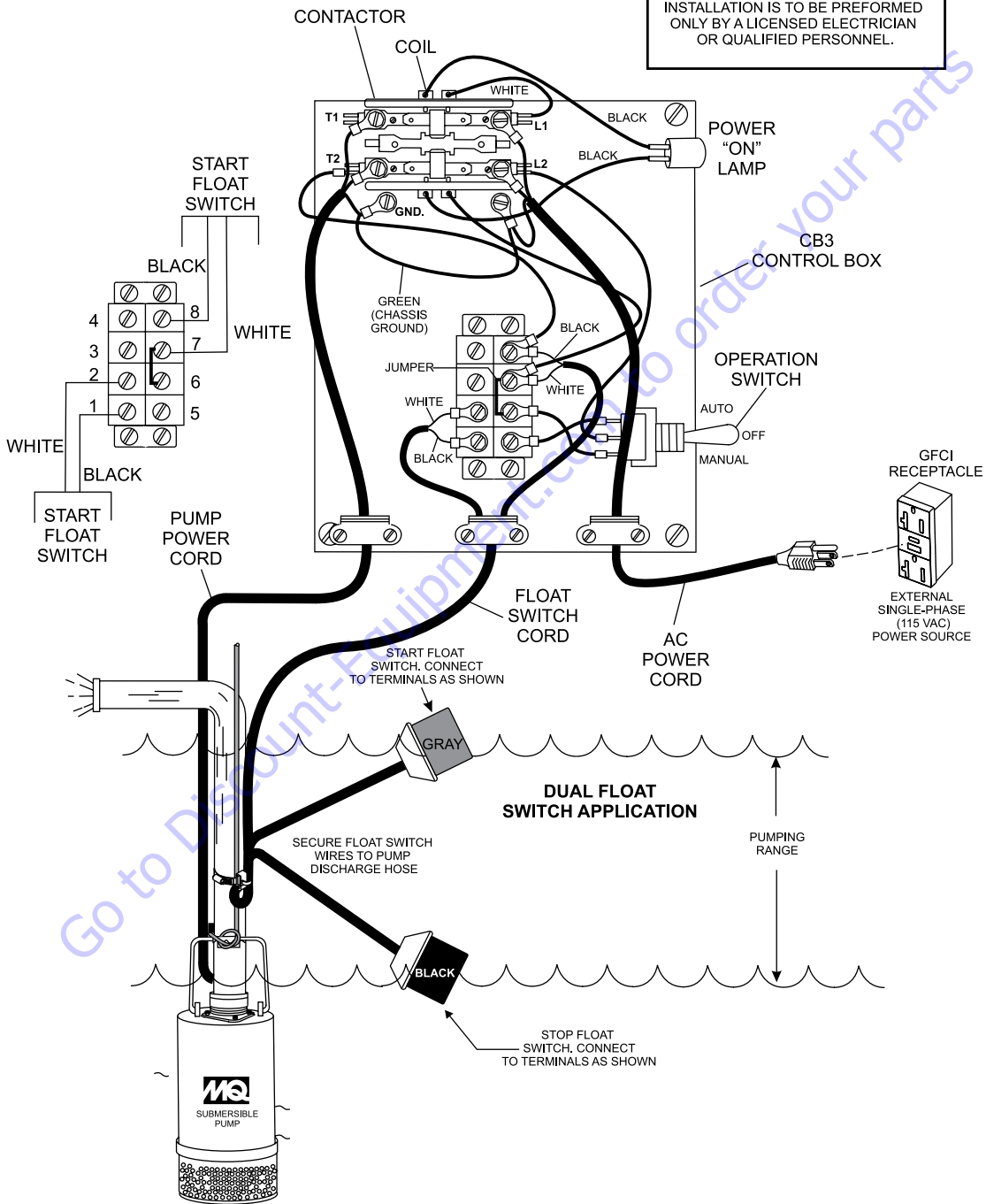

Figure 7. CB3 Control Box and Dual Float Switch Application Diagram

FLOAT SWITCH (CONTROL BOX)

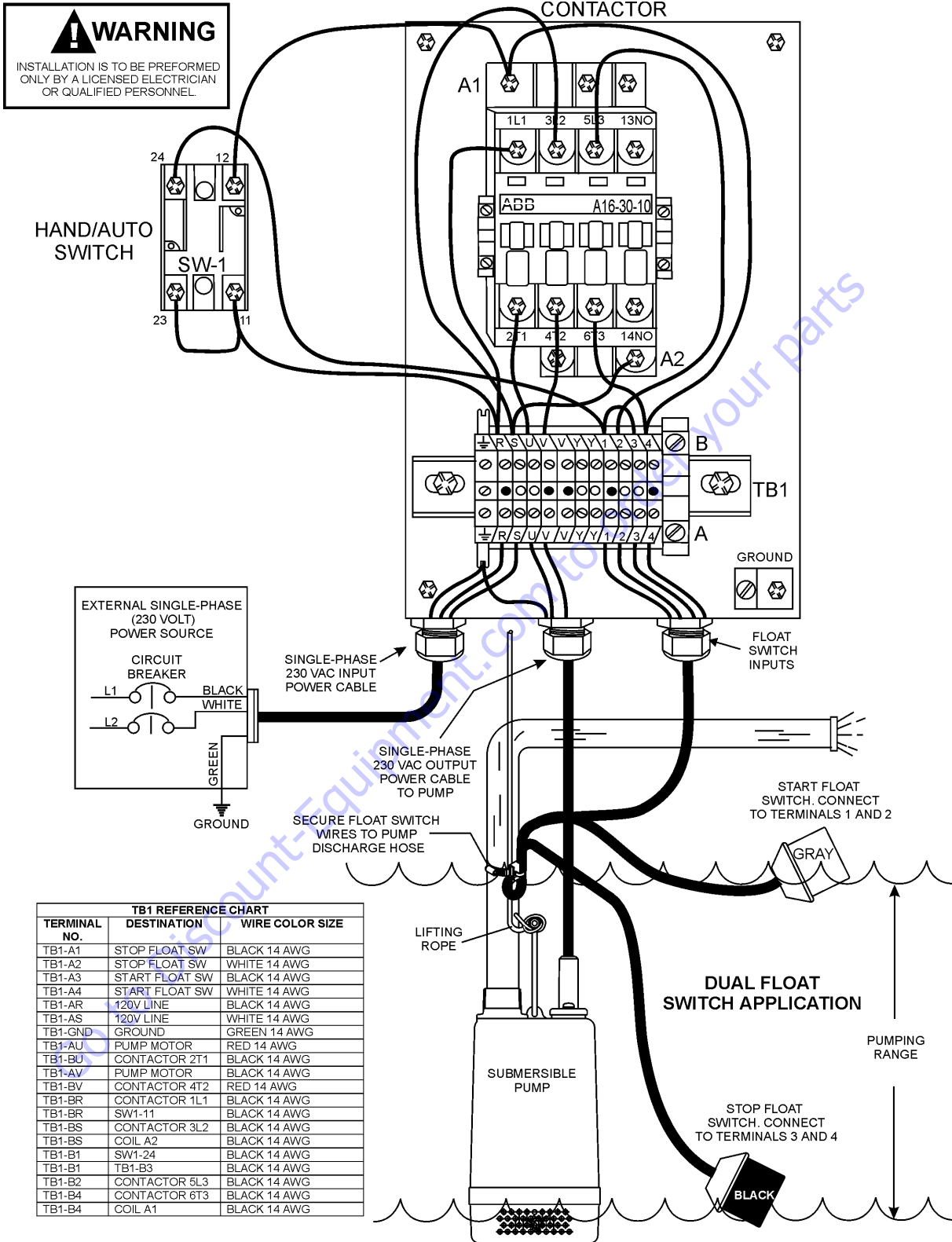

Figure 8. CB6 Control Box and Dual Float Switch Application Diagram

HOSE CONNECTIONS

Connect a 2-inch hose to the discharge port on the pump as shown in Figure 9. Make sure that the hose is attached correctly to the discharge port.

PUMP POWER CONNECTIONS (PIGGY-BACK CORD ONLY)

1. Make sure the circuit breaker supplying power to the pump is in the OFF position.
2. Connect the float switch or switches to the AC power receptacle as shown in Figure 6.

ATTACHING LIFTING ROPE

1. Attach a suitable lifting cable (rope) to the carrying handle (Figure 9) on the pump and lower the pump into place. For applications where there is an excessive amount of mud, grit or silt, the use of a support platform is desirable. When pumping water from swimming pool type applications where there is little or no debris, the support platform is not required.

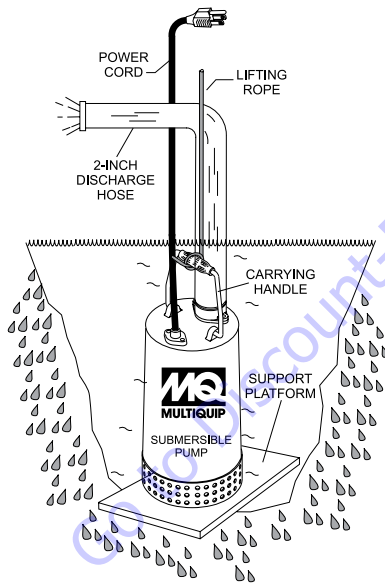

**Figure 9. Submersible Pump Upright
(Correct Position)**

2. Make sure the pump is always placed in an upright position, not tilted (Figure 10). Never position the pump directly on a soft, loose bottom. Remember to attain maximum pumping capacity and prevent excessive wear, position the pump so it will not burrow itself into sand or clay.

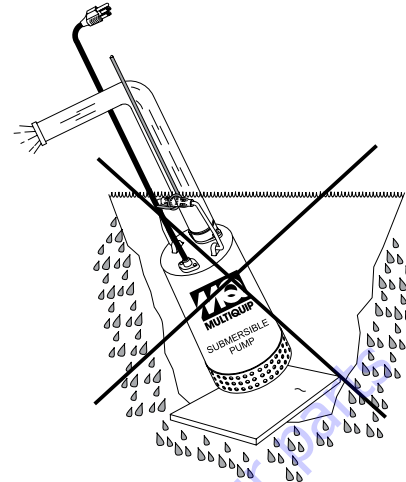

**Figure 10. Submersible Pump Tilted
(Incorrect Position)**

3. If all of the pump's electrical requirements have been met, place the circuit breaker or power ON/OFF switch in the ON position.
4. Wait a few seconds and water should begin to flow from the discharge hose.
5. If water is not flowing from the discharge hose or not flowing freely after a few minutes, remove the power from the pump and check the system for leaks.
6. To stop the pump from pumping, place the circuit breaker or ON/OFF switch in the OFF position.

! DANGER

NEVER grab or touch a live power cord (Figure 11). **DO NOT** stand in water when connecting the pump's power cord into a voltage source. The possibility exists of electrical shock, electrocution and possibly death!

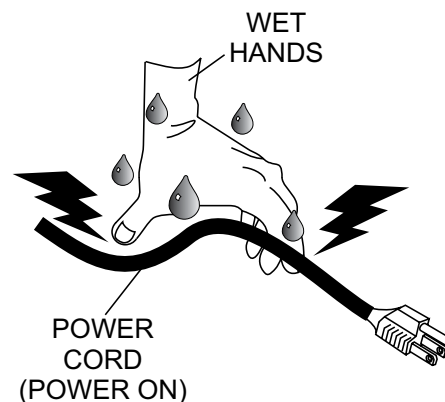

Figure 11. Power Cord (Wet Hands)

CONTROL BOX INSTALLATION

DANGER



The ST2010 Series submersible pumps are designed to work with a control box. The control box contains the necessary electronics (float switch connections) to operate the pump. Remember the control box contains hazardous voltages.

Disconnect all sources of power before installing or servicing. There exists the possibility of electrocution, electric shock or burn, which can cause severe bodily harm or even death!

CAUTION

This control box should only be installed or serviced by a licensed electrician or qualified personnel.

CONTROL BOX MOUNTING

Mount the control box in an upright vertical position. Make sure the control box is securely fastened to a flat surface, that is free of dust, dirt, moisture or any elements that may contaminate or erode the electronic components of the control box.

SINGLE-PHASE POWER INSTALLATION (INPUT)

The ST2010, ST2010A, ST2010CUL, and ST2010TCUL submersible pumps require 115 V, 60 Hz, single-phase power for normal operation. The ST2010B requires 230 V, 60 Hz, single-phase power.

If you cannot determine what your pump's power requirements are, look at the vendor supplied identification name tag attached to the pump or contact Multiquip's Service/Technical Assistance department.

CAUTION

Applying incorrect power (voltage phasing) to the submersible pump can cause severe damage to the pump. Please make sure that the correct voltage and phase are transferred to the pump at all times.

POWER CORD REQUIREMENTS

When routing the 115 VAC/230V, 60 Hz, single-phase power via a power cord to the control box, always use the correct wire size. Please refer to Table 4 below (Cord Length/Wire Size) to determine the correct wire size. Incorrect wire size can adversely affect the performance of the pump.

Table 4. Cord Length and Wire Size

AMPS	50 FT.	100 FT.	150 FT.
6	16 AWG	16 AWG	14 AWG
8	16 AWG	14 AWG	12 AWG
10	16 AWG	14 AWG	12 AWG
12	14 AWG	14 AWG	12 AWG
14	14 AWG	12 AWG	10 AWG
16	12 AWG	12 AWG	10 AWG

CONNECTING DUAL FLOAT SWITCH (SW-1WOP) TO CONTROL BOX

1. Remove the float switch input connector housing, then route the float switch wires through the cable gland on the control box. Attach the wires of the float switch to the terminal block as indicated by Table 5, Figure 7 and Figure 8.

Table 5. Float Switch Connections

Float Switch	Terminal Block Number
START	TERMINAL 1 (BLACK) TERMINAL 2 (WHITE)
STOP	TERMINAL 7 (WHITE) TERMINAL 8 (BLACK)

2. Tighten the connector housing to ensure a tight fit between the cord and the connector body. This will prevent the cable from pulling out of the terminal block and also prevent moisture from entering the control box.
3. Determine the length of the float switch wires, then secure float switch wires to pump discharge hose. See Figure 3 and Table 3 to determine the pumping range.

CONTROL BOX INSTALLATION

CONNECTING AC POWER TO THE CONTROL BOX

1. The AC power cord (input) should have three wires. Each wire is color coded. The colors are WHITE, BLACK and GREEN.
2. Remove the AC input connector housing from the control box, then route the power cord through the cable gland on the control box.
3. Connect the AC power cord to the contactor as shown in Figure 7 and Table 6.

Table 6. AC Input Power Connections to Contactor	
Float Switch	Terminal Block Number
BLACK	L1
WHITE	L2
GREEN	GROUND

4. Tighten the connector housing to ensure a tight fit between the power cord and the connector body. This will prevent the cable from pulling out of the terminal block and also prevent moisture from entering the control box.

NOTICE

It is recommended that the power being supplied to the control box always be connected to a circuit breaker or a quick disconnect switch. This safety feature allows for quick removal of power from the control box in the event of an emergency.

5. Connect the other end of the AC power cord to the voltage source. Remember to provide a means of disconnecting the power from the control box (circuit breaker or quick disconnect switch). Also make sure to provide a good earth ground to the control box.

CONNECTING AC POWER TO THE PUMP

1. AC power is transferred to the pump via a contactor. The coil of the contactor is energized or de-energized by the opening and closing of the float switch contacts. The power cord should have three wires. Each wire is color coded. The colors are WHITE, BLACK and GREEN.

2. Remove the pump AC input connector housing from the control box, then route the power cord through the cable gland on the control box.
3. Connect the pump power cord to the contactor as shown in Figure 7 and Table 7.

Table 7. AC Output Power Connections to Pump

Cable Wire Color	Contactor
BLACK	T1
WHITE	T2
GREEN	GROUND

NOTICE

Electrical connections to the power source should only be performed by a licensed electrician or qualified personnel.

TURNING ON THE PUMP

1. If all of the pump's electrical requirements have been met, place the circuit breaker or power ON/OFF switch in the ON position.
2. The CB3 control box has an operation switch located on the front cover. This switch has 3 positions; AUTO, MANUAL and OFF. The AUTO position allows the pump to run in an unattended mode. The MANUAL position will let the pump run without the float switches controlling the pump. When in the manual mode, be careful not to let the pump run dry. Severe damage to the pump may occur if it is allowed to run dry.
3. Place the operation switch in the AUTO position. The AC power indicator lamp should be lit (ON).
4. Wait a few seconds and water should begin to flow from the discharge hose.
5. If water is not flowing from the discharge hose or not flowing freely after a few minutes, remove the power from the pump and check the system for leaks.
6. To stop the pump from pumping, place the operation switch in the OFF position.

PUMP SHUT-DOWN/CLEAN-UP

1. Remove the power from the pump by turning off the circuit breaker or switch that provides power to the pump. Remember to make sure that hands are dry (not wet), and feet are not standing in water when removing disconnecting power from the pump.
2. Using the lifting rope, lift the pump up from its current position. Remove the discharge hose from the discharge port on the pump.
3. Remove all power cables and float switches from the control box. Place cables and float switches in a suitable container where they will not get damaged.
4. If the pump was used to pump mud, grit or silt, flush vigorously with clean water.
5. Remove the pump from the water. Wipe off any mud or debris that might have attached itself to the pump.
6. Store pump in a clean dry place away from dirt and debris.

Go to Discount-Equipment.com to order your parts

LUBRICATION

To check the oil level of the mechanical seal perform the following:

1. Lay the pump (Figure 12) on its side with the oil plug facing upwards.
2. Remove oil fill plug.
3. Visually inspect oil plug hole to verify that oil cavity is full enough to cover seal spring. Check every 300 hours. Change hydraulic oil every 6 months (1,000 hours) or as needed.
4. While checking the hydraulic oil level, also check the condition of the hydraulic oil in the seal cavity. Block the opening with a finger and roll pump to one side to drain oil into a small transparent container. If oil is cloudy or has water in it, drain oil from pump cavity and replace hydraulic oil. Check the seal for wear damage.

5. If oil level is low, fill with SAE 10 weight non-detergent hydraulic oil (i.e. Shell Turbo 32 or equivalent). Fill oil cavity 75% to 85% full (allow air space for expansion). See Table 1 for pump oil cavity capacity.

IMPELLER

1. Make sure the clearance between the impeller and the friction disk is approximately .012 - .020 inches (.304 - .508 mm.)
2. If impeller is defective or badly worn, replace impeller immediately.

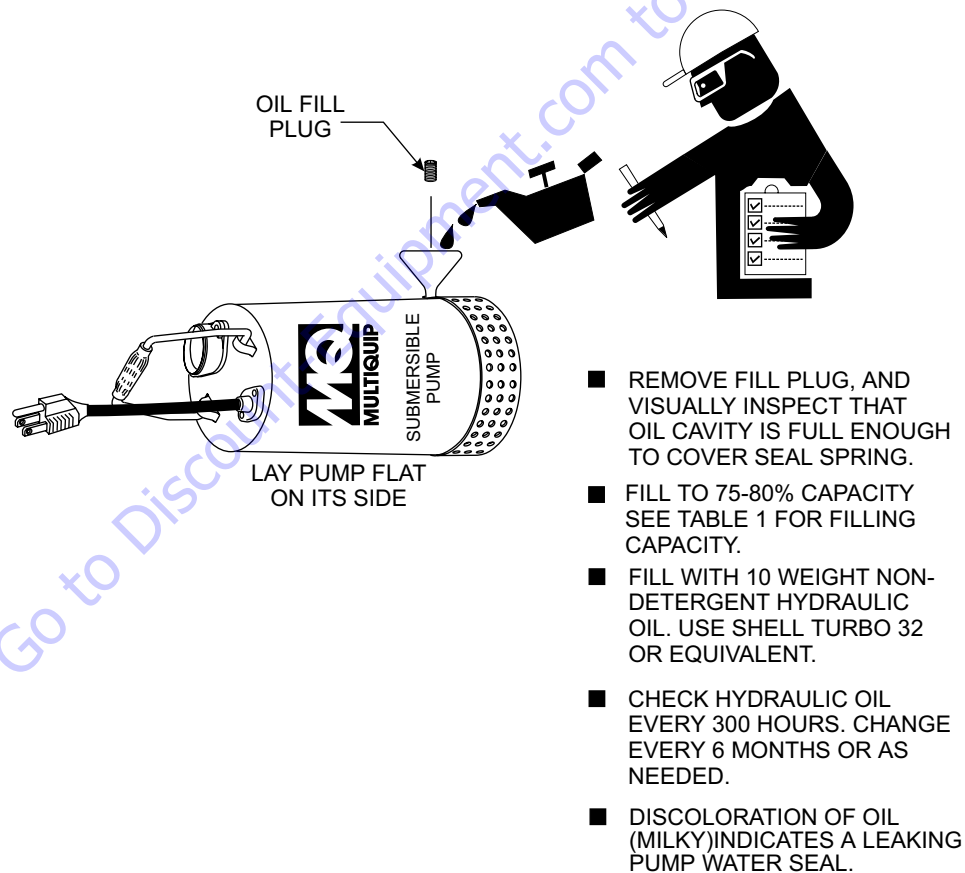

Figure 12. Checking Hydraulic Oil

TROUBLESHOOTING

Troubleshooting (Pump)		
Symptom	Possible Problem	Solution
Pump Fails To Start	Incorrect voltage/amps?	Check that proper voltage is being supplied to the pump. Also check that there is an adequate amount of current (amps) to run the pump. Check power source circuit breaker.
	Check electrical connections?	If using float switches check wiring, inspect power cord.
	Blown power fuse?	Replace fuse, check cause of blown fuse.
	Impeller locked?	Disconnect power cord and check for clogging and improper impeller clearance. Unclog pump. Check overload protection device.
	Wet motor windings?	Use multimeter to check motor insulation. Insulation resistance must be greater than 15 megaohms. If resistance is low, disassemble pump motor and bake windings to dry them.
	Defective motor and pump bearings?	Check for excessive bearing wear. If worn, replace bearings. Replace motor if defective.
Pump Fails to Deliver Full Output	Twisted or restricted discharge hose?	Lay hose flat unkinked. Remove clog from hose line.
	Clogged pump strainer?	Clean strainer.
	Low voltage?	Use a voltmeter to check voltage while pump is energized. Voltage must be within $\pm 10\%$. Check power source (no load and load). If an extension cord is used, make sure it has adequate current-carrying capacity for the required length. See Cord Length and Sizes Table.
	Impeller worn?	Replace impeller.
Water in Seal Oil	Defective water seal?	Replace water seal.
	Loose Oil Fill Plug?	Tighten securely.

PERFORMANCE CURVES

ST2010TCUL

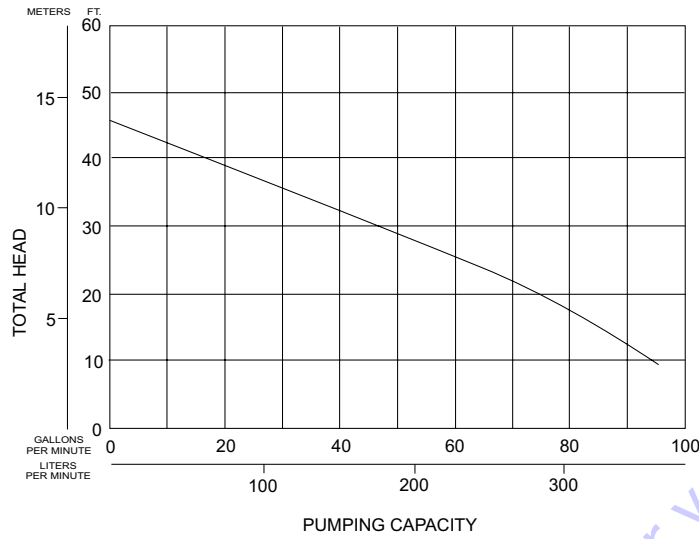

ST2010CUL

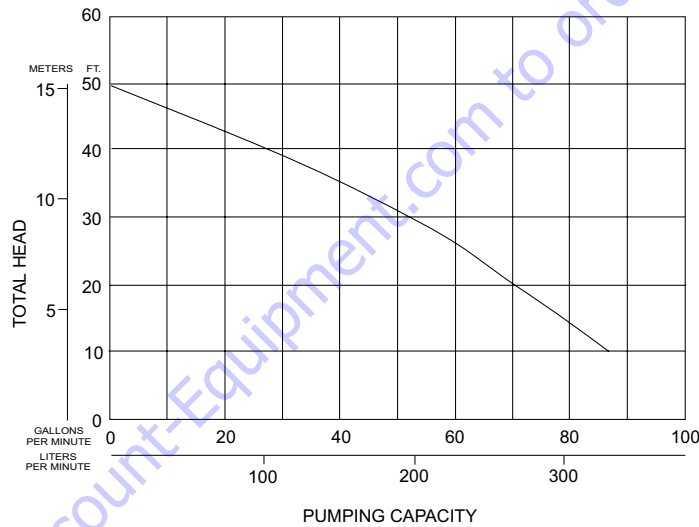

ST2010, ST2010A, ST2010B

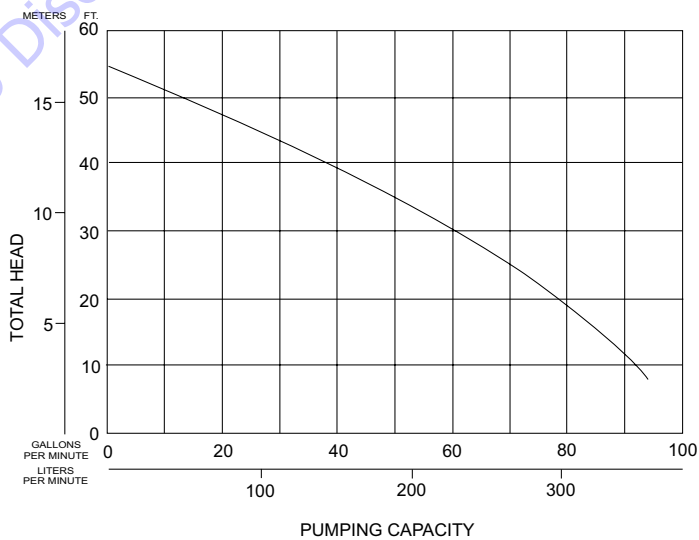

CONTROL BOX WIRING DIAGRAM

CB3 CONTROL BOX WIRING DIAGRAM

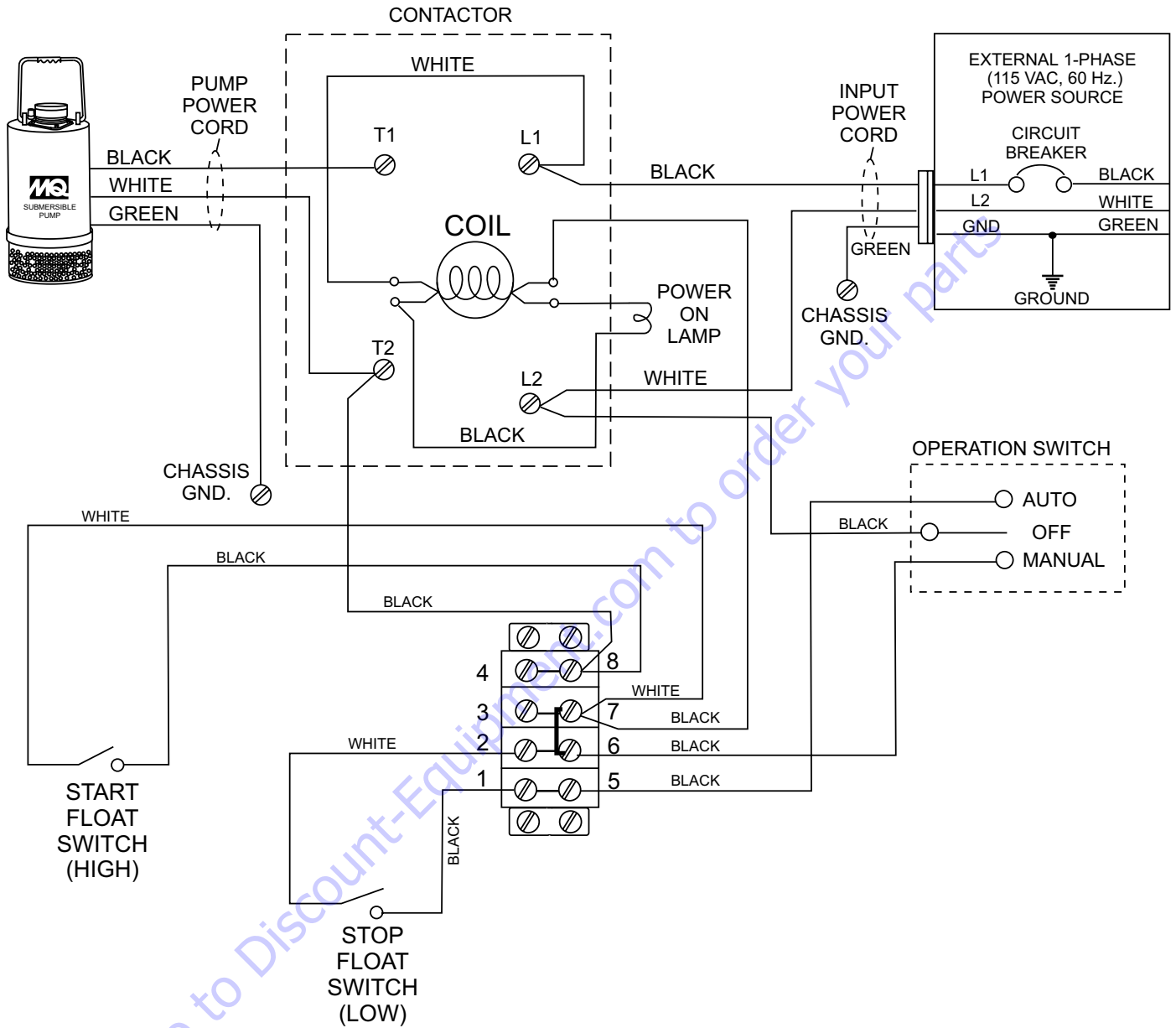

CONTROL BOX WIRING DIAGRAM

CB6 CONTROL BOX WIRING DIAGRAM

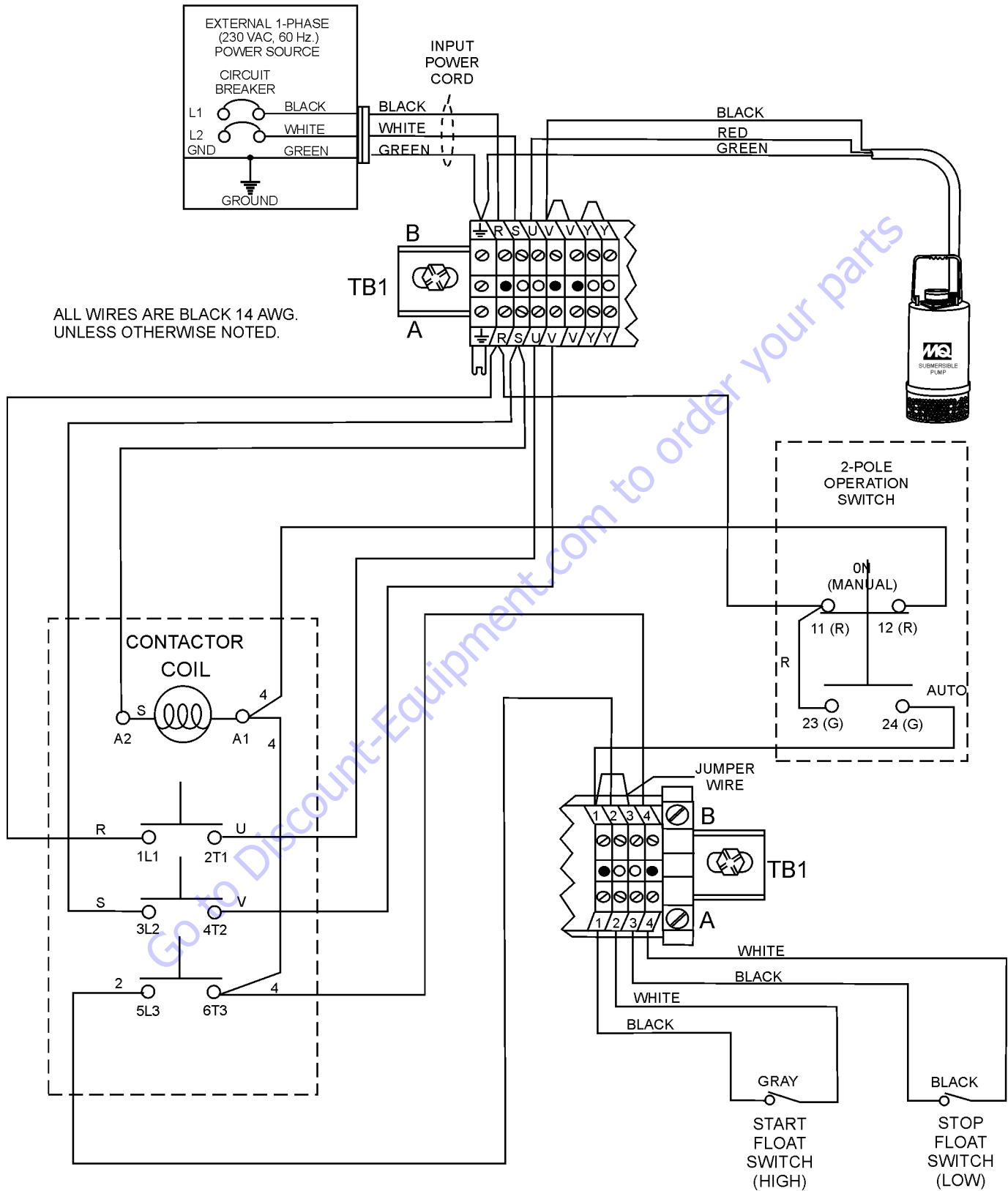

MOTOR WIRING DIAGRAM

ST-2010, ST-2010A, ST-2010B, ST-2010CUL ELECTRIC MOTOR WIRING DIAGRAM

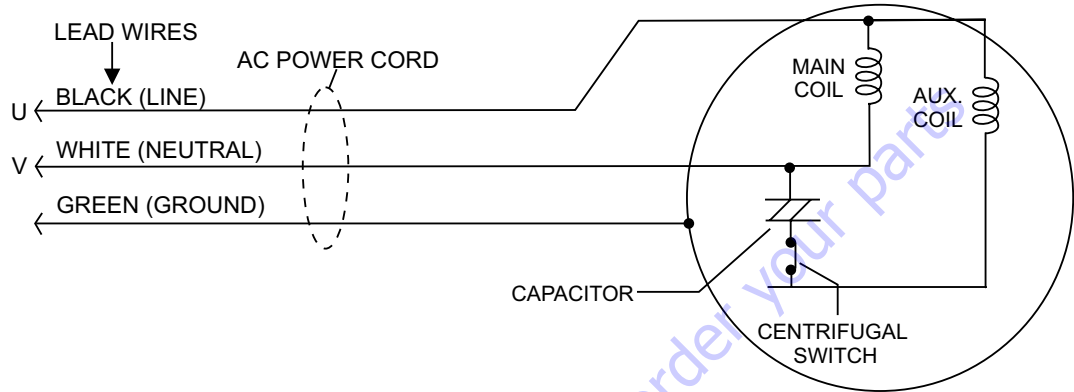

ST2010-TCUL ELECTRIC MOTOR WIRING DIAGRAM

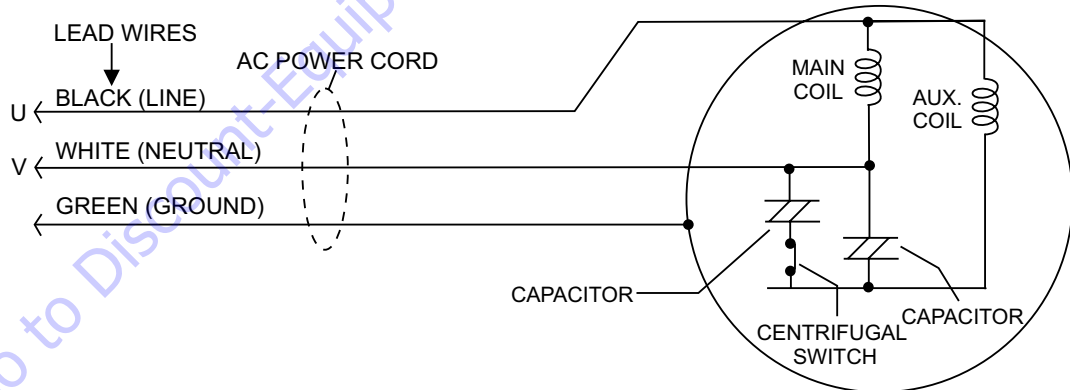

EXPLANATION OF CODE IN REMARKS COLUMN

The following section explains the different symbols and remarks used in the Parts section of this manual. Use the help numbers found on the back page of the manual if there are any questions.

NOTICE

The contents and part numbers listed in the parts section are subject to change **without notice**. Multiquip does not guarantee the availability of the parts listed.

SAMPLE PARTS LIST

NO.	PART NO.	PART NAME	QTY.	REMARKS
1	12345	BOLT	1	INCLUDES ITEMS W/%
2%		WASHER, 1/4 IN.		NOT SOLD SEPARATELY
2%	12347	WASHER, 3/8 IN. ...	1	MQ-45T ONLY
3	12348	HOSE	A/R	MAKE LOCALLY
4	12349	BEARING	1	S/N 2345B AND ABOVE

NO. Column

Unique Symbols — All items with same unique symbol

(@, #, +, %, or >) in the number column belong to the same assembly or kit, which is indicated by a note in the “Remarks” column.

Duplicate Item Numbers — Duplicate numbers indicate multiple part numbers, which are in effect for the same general item, such as different size saw blade guards in use or a part that has been updated on newer versions of the same machine.

NOTICE

When ordering a part that has more than one item number listed, check the remarks column for help in determining the proper part to order.

PART NO. Column

Numbers Used — Part numbers can be indicated by a number, a blank entry, or TBD.

TBD (To Be Determined) is generally used to show a part that has not been assigned a formal part number at the time of publication.

A blank entry generally indicates that the item is not sold separately or is not sold by Multiquip. Other entries will be clarified in the “Remarks” Column.

QTY. Column

Numbers Used — Item quantity can be indicated by a number, a blank entry, or A/R.

A/R (As Required) is generally used for hoses or other parts that are sold in bulk and cut to length.

A blank entry generally indicates that the item is not sold separately. Other entries will be clarified in the “Remarks” Column.

REMARKS Column

Some of the most common notes found in the “Remarks” Column are listed below. Other additional notes needed to describe the item can also be shown.

Assembly/Kit — All items on the parts list with the same unique symbol will be included when this item is purchased.

Indicated by:

“INCLUDES ITEMS W/(unique symbol)”

Serial Number Break — Used to list an effective serial number range where a particular part is used.

Indicated by:

“S/N XXXXX AND BELOW”

“S/N XXXX AND ABOVE”

“S/N XXXX TO S/N XXX”

Specific Model Number Use — Indicates that the part is used only with the specific model number or model number variant listed. It can also be used to show a part is NOT used on a specific model or model number variant.

Indicated by:

“XXXXX ONLY”

“NOT USED ON XXXX”

“Make/Obtain Locally” — Indicates that the part can be purchased at any hardware shop or made out of available items. Examples include battery cables, shims, and certain washers and nuts.

“Not Sold Separately” — Indicates that an item cannot be purchased as a separate item and is either part of an assembly/kit that can be purchased, or is not available for sale through Multiquip.

SUGGESTED SPARE PARTS

ST-2010 SERIES SUBMERSIBLE PUMP 1 TO 3 UNITS

Qty.	P/N	Description
10202010T120ACCORD WITH GLAND
10202010T081OIL SEAL
10202010T112OIL SEAL
10202010T008PACKING, CASING
10202010T060MECHANICAL SEAL
10202010T074PACKING
10202010T157PACKING
10202010T003IMPELLER

NOTICE

Part numbers on this Suggested Spare Parts list may supersede/replace the part numbers shown in the following parts lists.

Go to Discount-Equipment.com to order your parts

ST2010TCUL PUMP ASSY.

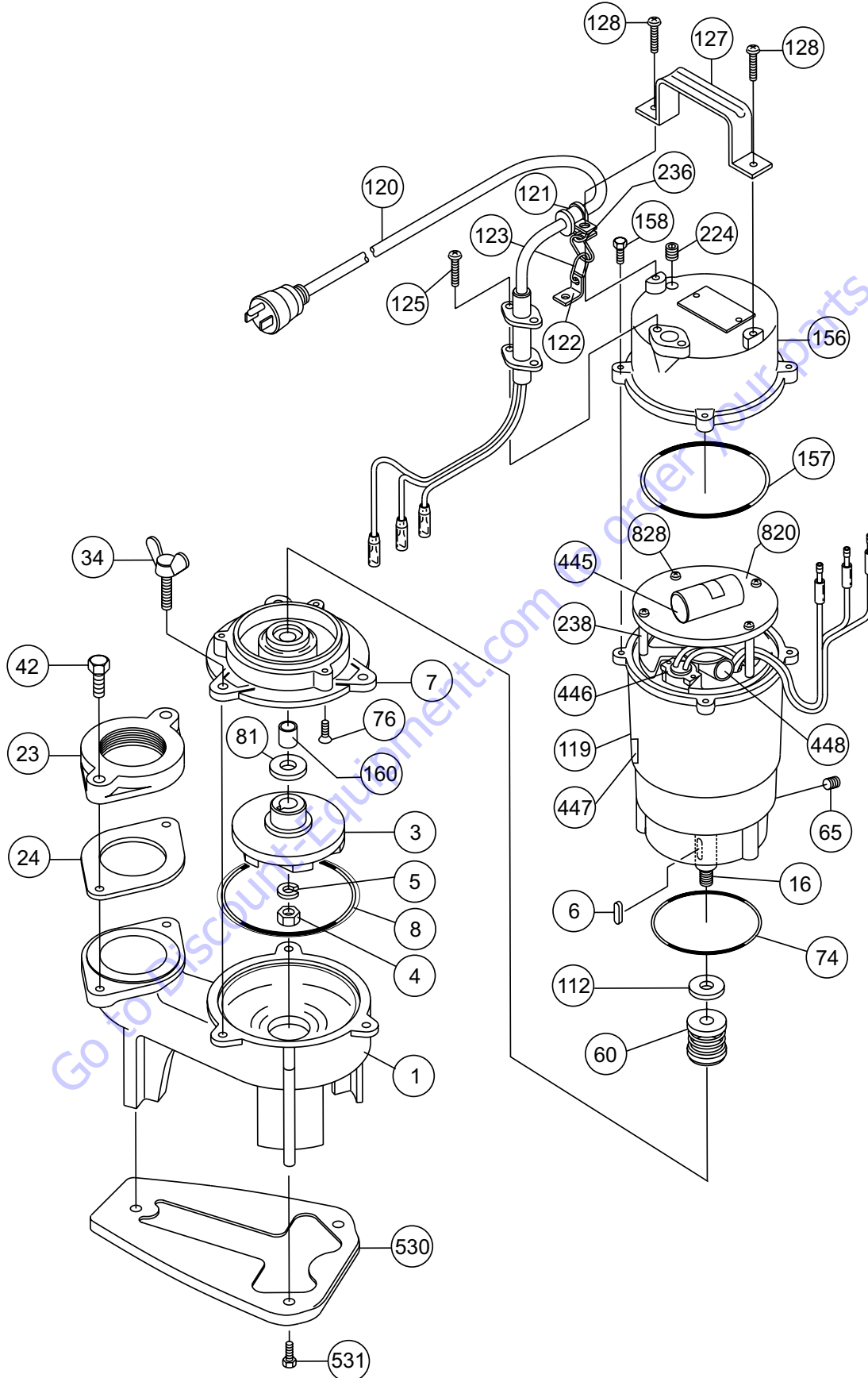

ST2010TCUL PUMP ASSY.

<u>NO.</u>	<u>PART NO.</u>	<u>PART NAME</u>	<u>QTY.</u>	<u>REMARKS</u>
1	0202005T001	CASING	1	
3	0202010T003	IMPELLER	1	
4	0202005T004	IMPELLER NUT	1	
5	0202005T005	SPRING WASHER	1	
6	0202005T006	IMPELLER KEY	1	
7	0202010T007	CASING COVER	1	
8	0202005T008	CASING PACKING	1	
16	0202010T016	SHAFT	1	
23	0202005T023	COMPANION FLANGE	1	
24	0202005T024	PACKING	1	
34	0202010T034	BOLT	3	
42	0202005T042	BOLT	2	
60	0202005T060	MECHANICAL SEAL	1	
65	0202005T065	PLUG	1	
74	0202010T074	PACKING	1	
76	0202005T076	BOLT	3	
81	0202005T081	OIL SEAL	1	
112	0202010T112	OIL SEAL	1	
119	0202010TCUL119	MOTOR	1	
120	0202010T120	AC CORD W/ CORD GLAND	1	
121	0202010T121	CORD CLAMP	1	
122	0202010T122	HANGER METAL	1	
123	0202010T123	CHAIN	1	
125	0202005T125	SCREW	2	
127	0202010T127	CARRYING HANDLE	1	
128	0202010T128	SCREW	2	
156	0202010T156	HEAD COVER	1	
157	0202010T157	PACKING	1	
158	0202010T158	BOLT	4	
160	0202005T160	SLEEVE	1	
224	0202005T224	PLUG	1	
236	0202010T236	S-TIP	1	
445	0202010T4551	CONDENSER STARTING	1	
446	0202010T446	AUTO-CUT (PROTECTOR)	1	
447	0202010T447	CENTRIFUGAL SWITCH	1	
448	0202010T4552	CONDENSER RUNNING	1	
820	0202010T820	MOUNTING PLATE, CONDENSER	1	
238	0202010T238	STANDOFF	4	
828	0202010T828	BOLT	4	
530	0202005T530	BOTTOM PLATE	1	
531	0202005T531	BOLT	3	

ST2010, ST2010A, ST2010B, ST2010CUL PUMP ASSY.

<u>NO.</u>	<u>PART NO.</u>	<u>PART NAME</u>	<u>QTY.</u>	<u>REMARKS</u>
1	0202005A001	CASING	1	
3	0202010CUL003	IMPELLER	1	ST2010CUL ONLY
3	0202010A003	IMPELLER	1	ST2010A ONLY
3	0202010003	IMPELLER	1	ST2010, ST2010B ONLY
4	0201503A004	IMPELLER NUT	1	
5	0201503A005	IMPELLER NUT WASHER	1	
6	0201503A006	IMPELLER KEY	1	
8	0201503UL008	CASING PACKING	1	
47	0201503A047A	LINER (0.2MM)	1	
47	0201503A047B	LINER (0.3MM)	1	
60	0201503A060	MECHANICAL SEAL	1	
65	0201503A065	PLUG	1	
81	0201503A081	OIL SEAL	1	
102	0202005A102	DISCHARGE PORT	1	ST2010A/B, ST2010CUL ONLY
103	0201503A103	PACKING	1	ST2010A/B, ST2010CUL ONLY
112	0201503A112	OIL SEAL FOR OIL CHAMBER.....	1	ST2010A/B, ST2010CUL ONLY
119	0202010119	MOTOR.....	1	ST2010 ONLY
119	0202010A119	MOTOR.....	1	ST2010A ONLY
119	0202010B119	MOTOR.....	1	ST2010B ONLY
119	0202010UL119	MOTOR.....	1	ST2010CUL ONLY
120	0202010120	AC CORD W/CORD GLAND	1	ST2010 ONLY
120	0202010A120	AC CORD W/CORD GLAND	1	ST2010A ONLY
120	0202010B120	AC CORD W/CORD GLAND	1	ST2010B ONLY
120	0202010UL120	AC CORD W/CORD GLAND.....	1	ST2010CUL ONLY
121	0201503A121	CORD CLAMP	1	
122	0201503A122	HANGER METAL	1	
123	0201503A123	CHAIN	1	
125	0201503A125	SCREW	2	
127	0202010127	CARRYING HANDLE.....	1	ST2010 ONLY
127	0202010A127	CARRYING HANDLE.....	1	ST2010A ONLY
127	0201503A127	CARRYING HANDLE.....	1	ST2010B, ST2010CUL ONLY
129	0202005129	FRAME COVER.....	1	ST2010 ONLY
129	0202005A129	FRAME COVER.....	1	ST2010A/B, ST2010CUL ONLY
130	0202005UL130	PACKING	1	
131	0202010131	BOLT	4	ST2010 ONLY
131	0202010A131	BOLT	4	ST2010A/B, ST2010CUL ONLY
132	0201503A132	SPRING WASHER	4	
146	0210503A146	STRAINER	1	
147	0201503A147	BOLT	3	
160	0201503A160	SLEEVE	1	
174	0202010174	OUTER PIPE	1	ST2010 ONLY
174	0202010A174	OUTER PIPE	1	ST2010A ONLY
174	0202010UL174	OUTER PIPE	1	ST2010B, ST2010CUL ONLY

ST2010, ST2010A, ST2010B, ST2010CUL PUMP ASSY.

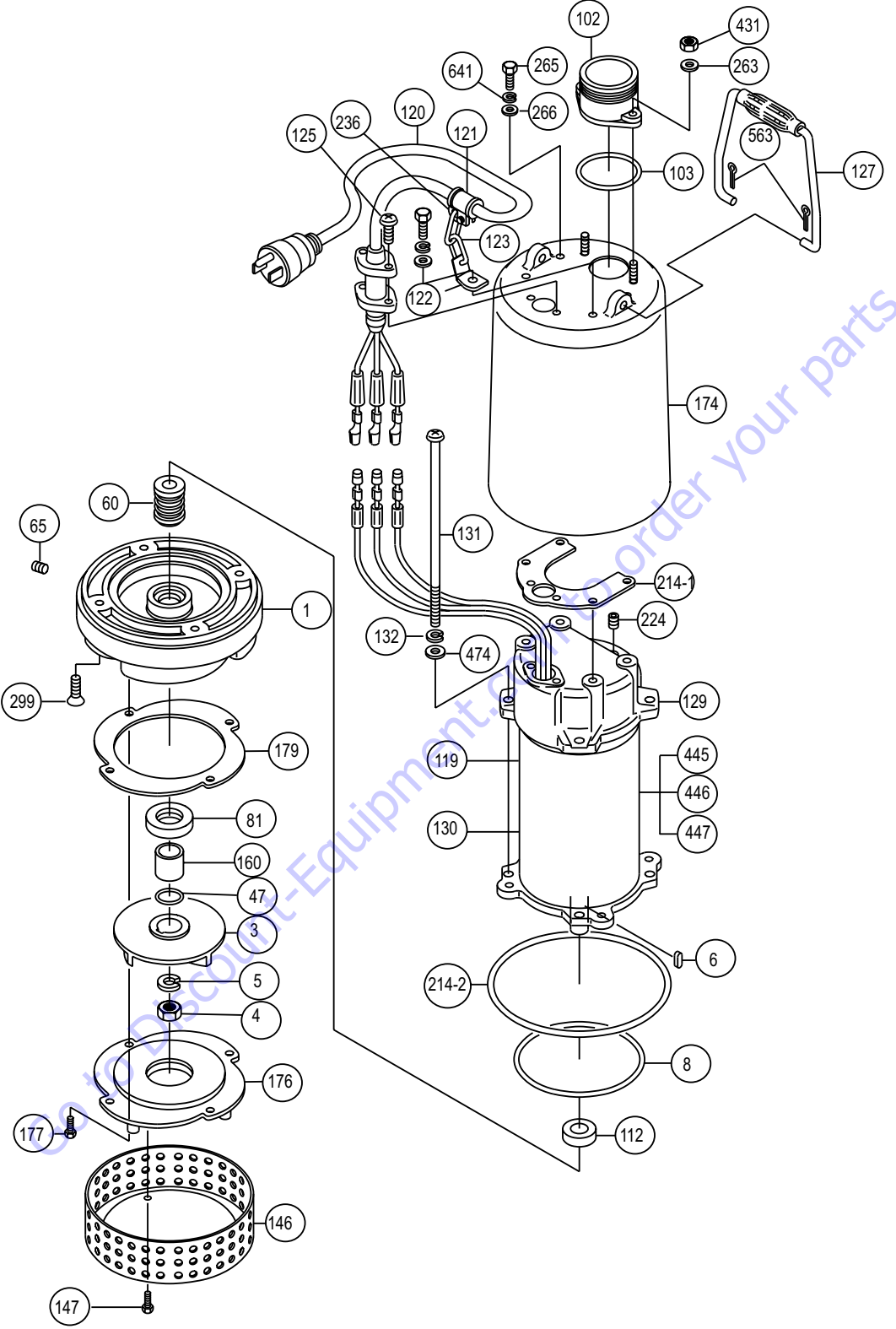

ST2010, ST2010A, ST2010B, ST2010CUL PUMP ASSY.

NO.	PART NO.	PART NAME	QTY.	REMARKS
176	0202010CUL176	SUCTION COVER	1.....	ST2010CUL ONLY
176	0202005176	SUCTION COVER	1.....	ST2010, ST2010B ONLY
176	0202005A176	SUCTION COVER	1.....	ST2010A ONLY
177	0201503A177	BOLT	4	
178	0201503A178	SPRING WASHER.....	4.....	ST2010, ST2010A ONLY
179	0202005A179	PACKING	1	
214-1	0201503UL214A	PACKING	1	
214-2	0201503A214B	PACKING	1	
224	0201503A224	PLUG	1	
236	0202005S236	S-TIP	1	
263	0401450080	WASHER	2.....	ST2010A/B, ST2010CUL ONLY
265	011206020	BOLT	4	
266	952404470	WASHER	4	
299	0202005299	SCREW 5 X 30	4.....	ST2010B, ST2010CUL ONLY
299	0202005A299	SCREW 6MM X 40MM	4.....	ST2010A ONLY
299	0202010299	SCREW.....	4.....	ST2010 ONLY
431	0202010A431	NUT.....	2.....	ST2010A/B, ST2010CUL ONLY
445	0202010445	CONDENSER	1.....	ST2010 ONLY
445	0202010A445	CONDENSER	1.....	ST2010A,ST-2010CUL ONLY
445	0202010B445	CONDENSER.....	1.....	ST2010B ONLY
446	0202010446	AUTO-CUT.....	1.....	ST2010 ONLY
446	0202010A446	AUTO-CUT.....	1.....	ST2010A ONLY
446	0202010B446	AUTO-CUT.....	1.....	ST2010B ONLY
446	0202010UL446	AUTO-CUT.....	1.....	ST2010CUL ONLY
447	0202005447	CENTRIFUGAL SWITCH	1.....	ST2010 ONLY
447	0202010A447	CENTRIFUGAL SWITCH	1.....	ST2010A ONLY
447	0202005A447	CENTRIFUGAL SWITCH	1.....	ST2010B,ST2010CUL ONLY
474	0201503A474	WASHER	4	
475	0202010475	ROPE.....	1.....	ST2010 ONLY
563	0201503A563	SPLIT PIN.....	2.....	ST2010A/B, ST2010CUL ONLY
641	030208200	SPRING WASHER.....	4.....	ST2010B,ST2010CUL ONLY

Go to DiscountEquipment.com to order your parts

ELECTRIC MOTOR ASSY.

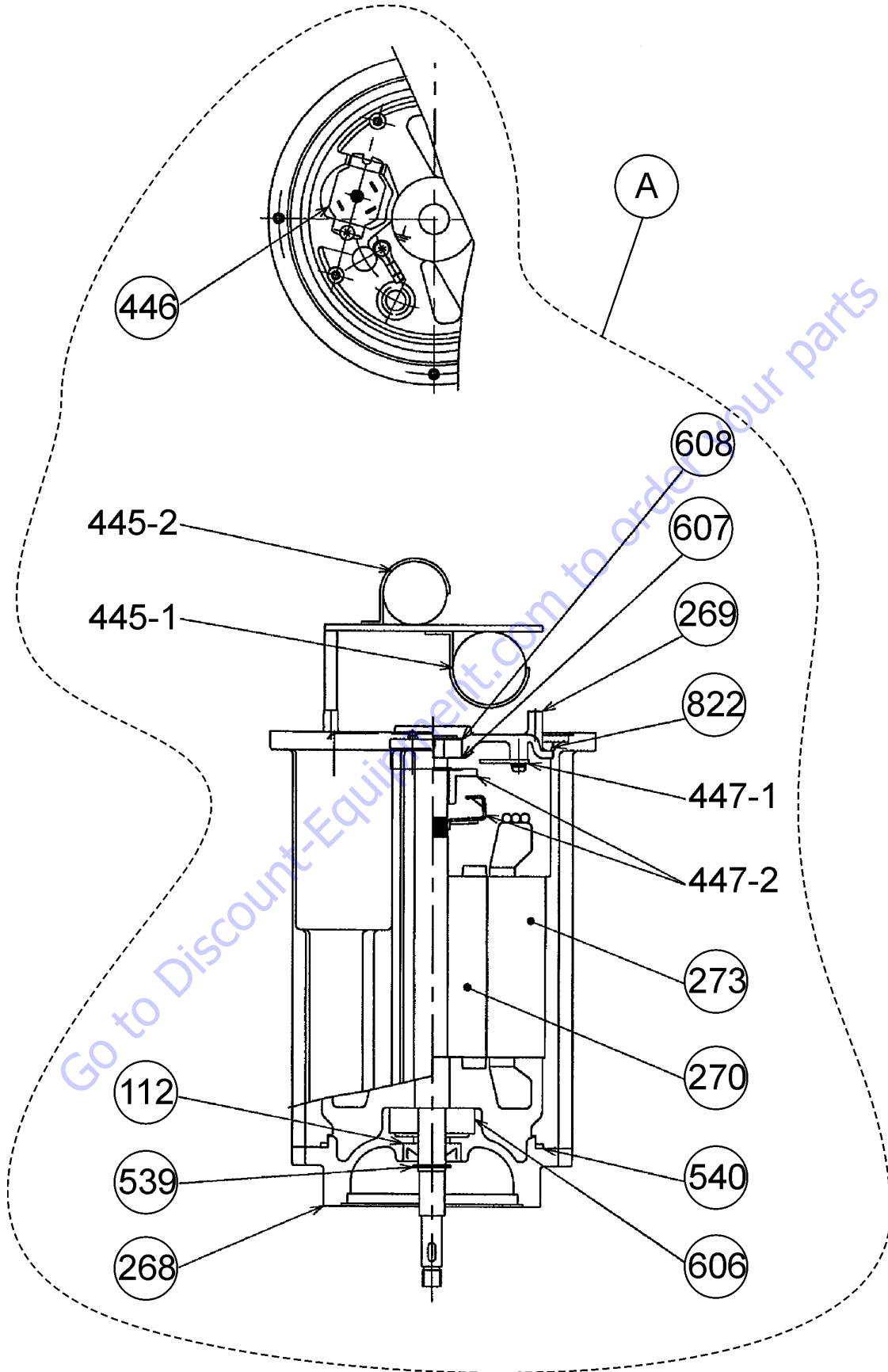

ELECTRIC MOTOR ASSY.

<u>NO.</u>	<u>PART NO.</u>	<u>PART NAME</u>	<u>QTY.</u>	<u>REMARKS</u>
112*	0202010T112	OIL SEAL	1	
268*	0202010T268	MOTOR A BRACKET	1	
269*	0202010T269	MOTOR B BRACKET	1	
270*	0202010T270	MOTOR ROTOR	1	
273*	0202010T273	MOTOR STATOR	1	
445-1*	0202010T4451	CONDENSER (STARTING)	1	
445-2*	0202010T4452	CONDENSER (RUNNING)	1	
446*	0202010T446	AUTO-CUT (PROTECTOR)	1	
447-1*	0202010T4471	CENTRIFUGAL SWITCH-1	1	
447-2*	0202010T4472	CENTRIFUGAL SWITCH-2	1	
539*	0202010T539	SNAP RING	1	
540*	0202010T540	A PACKING	1	
606*	0202010T606	MOTOR A BEARING	1	
607*	0202010S607	MOTOR B BEARING	1	
608*	0202010T608	WAVE WASHER	1	
822*	0202010T822	BRACKET RING	1	
A	0202010T119	MOTOR ASSEMBLY	1	INCLUDES ITEMS W/ *

Go to Discount-Equipment.com to order your parts

PARTS FINDER

**Search Website
by Part Number**



**Search Manual
Library For Parts
Manual & Lookup Part
Numbers – Purchase
or Request Quote**

Search Manuals

Enter your information to search for manuals and parts.

* Brand:

* Model:

* Serial:

* Part Number:

SEARCH

**Can't Find Part or
Manual? Request Help
by Manufacturer,
Model & Description**

Parts Order Form

Please fill in the following information:

Manufacturer:

Model:

Description:

Quantity:

Part Number:

Part Name:

Part Description:

Part Location:

Part Condition:

Part Status:

Part Color:

Part Material:

Part Weight:

Part Dimensions:

Part Price:

Part Notes:

Submit

Discount-Equipment.com is your online resource for quality parts & equipment.

Florida: **561-964-4949** Outside Florida TOLL FREE: **877-690-3101**

Need parts?

Click on this link: <http://www.discount-equipment.com/category/5443-parts/> and choose one of the options to help get the right parts and equipment you are looking for. Please have the machine model and serial number available in order to help us get you the correct parts. If you don't find the part on the website or on once of the online manuals, please fill out the request form and one of our experienced staff members will get back to you with a quote for the right part that your machine needs.

We sell worldwide for the brands: Genie, Terex, JLG, MultiQuip, Mikasa, Essick, Whiteman, Mayco, Toro Stone, Diamond Products, Generac Magnum, Airman, Haulotte, Barreto, Power Blanket, Nifty Lift, Atlas Copco, Chicago Pneumatic, Allmand, Miller Curber, Skyjack, Lull, Skytrak, Tsurumi, Husquvarna Target, , Stow, Wacker, Sakai, Mi-T- M, Sullair, Basic, Dynapac, MBW, Weber, Bartell, Bennar Newman, Haulotte, Ditch Runner, Menegotti, Morrison, Contec, Buddy, Crown, Edco, Wyco, Bomag, Laymor, Barreto, EZ Trench, Bil-Jax, F.S. Curtis, Gehl Pavers, Heli, Honda, ICS/PowerGrit, IHI, Partner, Imer, Clipper, MMD, Koshin, Rice, CH&E, General Equipment, ,AMida, Coleman, NAC, Gradall, Square Shooter, Kent, Stanley, Tamco, Toku, Hatz, Kohler, Robin, Wisconsin, Northrock, Oztec, Toker TK, Rol-Air, Small Line, Wanco, Yanmar