

OPERATION AND PARTS MANUAL



MODEL CX400/PX400 SUBMERSIBLE PUMPS



www.Discount-Equipment.com

Revision #3 (09/19/19)



THIS MANUAL MUST ACCOMPANY THE EQUIPMENT AT ALL TIMES.

TO PURCHASE THIS PRODUCT PLEASE CONTACT US



**Equipment Financing and
Extended Warranties Available**



**Discount-Equipment.com is your online resource for
commercial and industrial quality parts and equipment sales.**

561-964-4949

visit us on line @ www.discount-equipment.com

Select an option below to find your Equipment

Search by Manufacturer

Search by Product Type

Request a Quote

We sell worldwide for the brands: Genie, Terex, JLG, MultiQuip, Mikasa, Essick, Whiteman, Mayco, Toro Stone, Diamond Products, Generac Magnum, Airman, Haulotte, Barreto, Power Blanket, Nifty Lift, Atlas Copco, Chicago Pneumatic, Allmand, Miller Curber, Skyjack, Lull, Skytrak, Tsurumi, Husquvarna Target, Stow, Wacker, Sakai, Mi-T-M, Sullair, Basic, Dynapac, MBW, Weber, Bartell, Bennar Newman, Haulotte, Ditch Runner, Menegotti, Morrison, Contec, Buddy, Crown, Edco, Wyco, Bomag, Laymor, EZ Trench, Bil-Jax, F.S. Curtis, Gehl Pavers, Heli, Honda, ICS/PowerGrit, IHI, Partner, Imer, Clipper, MMD, Koshin, Rice, CH&E, General Equipment, Amida, Coleman, NAC, Gradall, Square Shooter, Kent, Stanley, Tamco, Toku, Hatz, Kohler, Robin, Wisconsin, Northrock, Oztec, Toker TK, Rol-Air, APT, Wylie, Ingersoll Rand / Doosan, Innovatech, Con X, Ammann, Mecalac, Makinex, Smith Surface Prep, Small Line, Wanco, Yanmar

PROPOSITION 65 WARNING

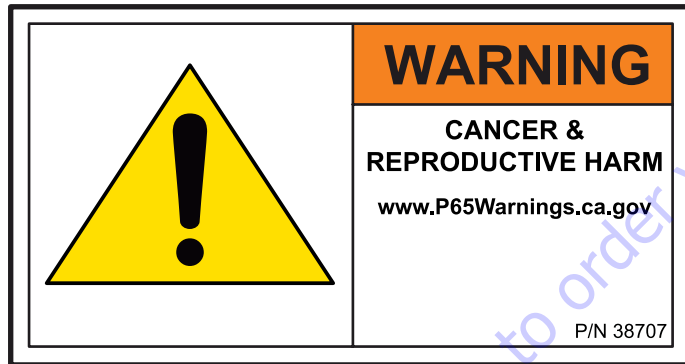

Go to Discount-Equipment.com to order your parts

TABLE OF CONTENTS

CX400/PX400 Submersible Pump

Proposition 65 Warning	2
Safety Information	4-7
Dimensions	8
Specification	9
Performance Curve.....	10
General Information.....	11
Components	12
Direct Power Operation	13
Float Switches	14
Float Switches	15
Float Switches (Control Box).....	16
Operation.....	17-20
Maintenance	21-23
Troubleshooting	24
Control Box (CB3) Wiring Diagram	25
Explanation of Code in Remarks Column.....	26
Suggested Spare Parts	27

Component Drawings

CX400 Pump Assembly.....	28-29
PX400 Pump Assembly.....	30-31

NOTICE

Specifications and part numbers are subject to change without notice.

SAFETY INFORMATION

Do not operate or service the equipment before reading the entire manual. Safety precautions should be followed at all times when operating this equipment. Failure to read and understand the safety messages and operating instructions could result in injury to yourself and others.



SAFETY MESSAGES

The four safety messages shown below will inform you about potential hazards that could injure you or others. The safety messages specifically address the level of exposure to the operator and are preceded by one of four words: **DANGER**, **WARNING**, **CAUTION** or **NOTICE**.

SAFETY SYMBOLS

! **DANGER**

Indicates a hazardous situation which, if not avoided, **WILL** result in **DEATH** or **SERIOUS INJURY**.

! **WARNING**

Indicates a hazardous situation which, if not avoided, **COULD** result in **DEATH** or **SERIOUS INJURY**.

! **CAUTION**

Indicates a hazardous situation which, if not avoided, **COULD** result in **MINOR** or **MODERATE INJURY**.

NOTICE

Addresses practices not related to personal injury.

Potential hazards associated with the operation of this equipment will be referenced with hazard symbols which may appear throughout this manual in conjunction with safety messages.

Symbol	Safety Hazard
	Burn hazards
	Electric shock hazards
	Rotating parts hazards
	Pressurized fluid hazards

SAFETY INFORMATION

GENERAL SAFETY

CAUTION

- **NEVER** operate this equipment without proper protective clothing, shatterproof glasses, respiratory protection, hearing protection, steel-toed boots and other protective devices required by the job or city and state regulations.



- Avoid wearing jewelry or loose fitting clothes that may snag on the controls or moving parts as this can cause serious injury.

- **NEVER** operate this equipment when not feeling well due to fatigue, illness or when under medication.



- **NEVER** operate this equipment under the influence of drugs or alcohol.



- **ALWAYS** clear the work area of any debris, tools, etc. that would constitute a hazard while the equipment is in operation.

- No one other than the operator is to be in the working area when the equipment is in operation.

- **DO NOT** use the equipment for any purpose other than its intended purposes or applications.

NOTICE

- This equipment should only be operated by trained and qualified personnel 18 years of age and older.
- Whenever necessary, replace nameplate, operation and safety decals when they become difficult read.
- Manufacturer does not assume responsibility for any accident due to equipment modifications. Unauthorized equipment modification will void all warranties.
- **NEVER** use accessories or attachments that are not recommended by Multiquip for this equipment. Damage to the equipment and/or injury to user may result.
- **ALWAYS** know the location of the nearest fire extinguisher.
- **ALWAYS** know the location of the nearest first aid kit.
- **ALWAYS** know the location of the nearest phone or **keep a phone on the job site**. Also, know the phone numbers of the nearest **ambulance, doctor and fire department**. This information will be invaluable in the case of an emergency.



PUMP SAFETY

DANGER

- **NEVER** operate the equipment in an explosive atmosphere or near combustible materials. An explosion or fire could result causing severe **bodily harm or even death**.



WARNING

- Accidental starting can cause severe injury or death. **ALWAYS** place the ON/OFF switch in the OFF position.
- **DO NOT** place hands or fingers inside pump when pump is running.



SAFETY INFORMATION

- **NEVER** disconnect any **emergency or safety devices**. These devices are intended for operator safety. Disconnection of these devices can cause severe injury, bodily harm or even death. Disconnection of any of these devices will void all warranties.
- **Risk of Electric Shock** - Do not enter the pool or spa if the pump is operating.

CAUTION

- Be careful of discharge hose whipping under pressure.
- **ALWAYS** check pump oil level only when pump is cool. Expansion due to heat may cause hot oil to spray from the oil plug when the oil plug is removed. The possibility of severe scalding may exist.

NOTICE

- **ALWAYS** place the pump in an upright position on a platform before using. The platform will prevent the pump from burrowing itself on soft sand or mud.
- **NEVER** operate pump on its side.
- **DO NOT** allow the pump to freeze in water.
- **NEVER** leave an open pump chamber unattended.
- **ALWAYS** keep the machine in proper running condition.
- **DO NOT** attempt to thaw out a frozen pump by using a torch or other source of flame. Application of heat in this manner may heat the oil in the seal cavity above the critical point, causing pump damage.
- **DO NOT** pump water with a temperature greater than 140°F (60°C).
- **DO NOT** pump liquids containing acid or alkali.
- **ALWAYS** check strainer before pumping. Make sure strainer is not clogged. Remove any large objects, dirt or debris from the strainer to prevent clogging.
- **ALWAYS** use a large basket strainer when pumping water that contains large debris.
- **ALWAYS** flush pump (clean) after use when pumping water concentrated with heavy debris. It is very important to always flush the pump before turning it off to prevent clogging.
- Fix damage to machine and replace any broken parts immediately.
- **ALWAYS** store equipment properly when it is not being used. Equipment should be stored in a clean, dry location out of the reach of children and unauthorized personnel.

- **NEVER** lubricate components or attempt service on a running machine.
- **NEVER** run pump *dry*.
- **ALWAYS** allow the machine a proper amount of time to cool before servicing.
- Keep machine in proper running condition.

ELECTRICAL SAFETY

DANGER

- The electrical voltage required to operate pump can cause severe injury or even death through physical contact with live circuits. **ALWAYS** disconnect electrical power from pump before performing maintenance on pump.



WARNING

- To reduce the risk of electric shock, connect to a circuit protected by a Ground-Fault Circuit-Interrupter (GFCI).
- **Risk of Electric Shock** - This pump is supplied with a grounding conductor and grounding-type attachment plug. To reduce the risk of electric shock, be certain that it is connected only to a properly grounded, grounding-type receptacle.

AVERTISSEMENT

- Risques de chocs électriques. Cette pompe est alimentée en électricité au moyen d'un conducteur et d'une fiche d'alimentation de terre. Afin de réduire les risques de chocs électriques, s'assurer que la pompe est uniquement connectée à des boîtiers de protection de mise à la terre correctement enterrés.

NOTICE

- **ALWAYS** make certain that the voltage supplied to the pump is correct. Always read the pump's nameplate to determine what the power requirements are.

SAFETY INFORMATION

Power Cord/Cable Safety

DANGER

- **NEVER** stand in water while AC power cord is connected to a live power source.
- **NEVER** use **damaged** or **worn** cables or cords. Inspect for cuts in the insulation.
- **NEVER** grab or touch a live power cord or cable with wet hands. The possibility exists of **electrical shock, electrocution or death.**
- Make sure power cables are securely connected to the motor's output receptacles. Incorrect connections may cause electrical shock and damage to the motor.

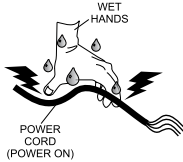

WARNING

- **NEVER** attempt to use the power cord as a lifting or lowering device for the pump.

NOTICE

- **ALWAYS** make certain that proper power or extension cord has been selected for the job. See Cable Selection Chart in this manual.

Grounding Safety

DANGER

- **ALWAYS** make sure pump is grounded.
- **NEVER** use gas piping as an electrical ground.
- **ALWAYS** make sure that electrical circuits are properly grounded to a suitable earth ground (ground rod) per the National Electrical Code (NEC) and local codes before operating generator. **Severe injury or death by electrocution** can result from operating an ungrounded motor.

Control Box Safety

DANGER

- **ALWAYS** have a qualified electrician perform the control box installation. The possibility exists of electrical shock or electrocution.

NOTICE

- **ALWAYS** mount control box in a vertical position protected from harsh environmental elements.

LIFTING SAFETY

CAUTION

- When raising or lowering of the pump is required, always attach an adequate rope or lifting device to the correct lifting point (handle) on the pump.

NOTICE

- **NEVER** lift the equipment while the electric motor is running.

TRANSPORTING SAFETY

NOTICE

- **ALWAYS** shut down pump before transporting.
- **ALWAYS** tie down equipment during transport.

ENVIRONMENTAL SAFETY/DECOMMISSIONING

- **DO NOT** pour waste or oil directly onto the ground, down a drain or into any water source.
- Contact your country's Department of Public Works or recycling agency in your area and arrange for proper disposal of any electrical components, waste or oil associated with this equipment.
- When the life cycle of this equipment is over it is recommended that the pump casing and all other metal parts be sent to a recycling center



Metal recycling involves the collection of metal from discarded products and its transformation into raw materials to use in manufacturing a new product.

Recyclers and manufacturers alike promote the process of recycling metal. Using a metal recycling center promotes energy cost savings.

DIMENSIONS

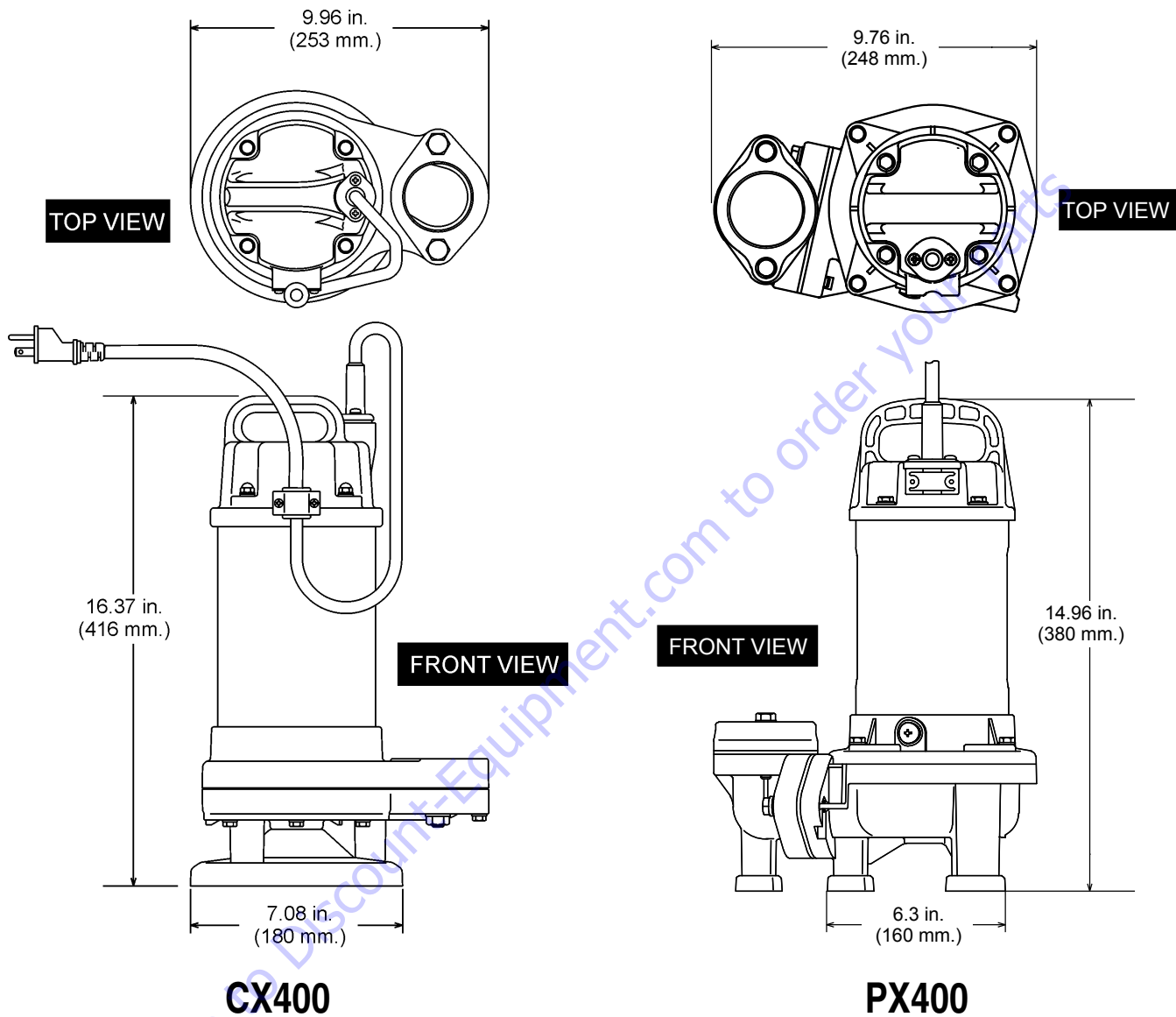

Figure 1. CX400/PX400 Pump Dimensions

Table 1. Specifications		
Model	CX400/PX400	
Type	Submersible Trash Pump	
Motor Type	Condenser Start	Condenser Drive
Impeller	Plastic	
Suction & Discharge Size	2 in. (50 mm)	
Maximum Pumping Capacity	72 gallons/minute/(273 liters/minute)	
Max Head	34 ft. (10.3 meters)	
Power	1/2 HP (.37 kw)	
Voltage Phase	1Ø 115 V	
Starting Amps	35.4	18.4
Running Amps	7	6.2
Control Box Required	NO (See Note 3)	
Temperature Range	32° - 104°F (0° - 40°C)	
Thermal Overload Protection	YES	
Rotation	CCW (See Note 1)	
Mechanical Seal Oil Capacity	15.54 in ³ (255 cc) (See Note 2)	10.67 in ³ (175 cc) (See Note 2)
Power Cable Length	19 ft (approximately 6 m)	
Dry Net weight	21.4 lb (9.7 kg)	18.3 lb (8.3 kg)

1. **Motor Rotation** – Upon start-up, the pump "**kicks**" in the opposite direction of motor rotation. The correct rotation is counterclockwise (CCW) as viewed from the impeller end of the pump.
2. **Mechanical Seal Oil** – Use Paraffin P70 oil lubricant. Fill oil cavity 75% to 85% full (allow air space for expansion).
3. **Control Box** - For unattended operation use CB3 Control box (Table 2).

Table 2. Control Box Specifications				
Model	Voltage Type	UL/CSA Listed	Thermal Overload Protection	Float Switch Capability
CB3	115 VAC, 60 Hz Single Phase	YES	NO	YES

PERFORMANCE CURVE

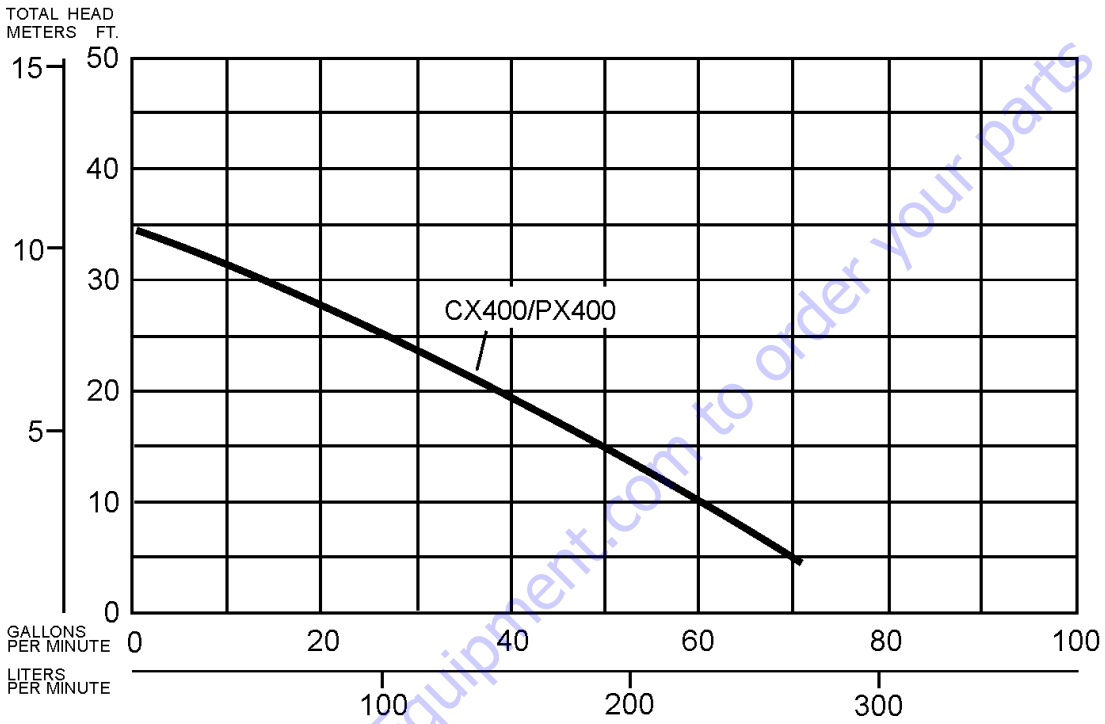

Figure 2. Pump Performance Curve

GENERAL INFORMATION

The Multiquip Model CX400 and PX400 submersible pumps are designed to pump water and is used for the draining (dewatering) of well casings construction sites, coffer dams, manholes, transformer vaults and excavations.

Its slim design, only 10 inches (25.4 cm.) in diameter allows it to fit easily inside casings and eliminates the need for larger, more costly casings. The pump is powered by a 1/2 HP, 115-volt, single-phase motor for easy starting with a small 2,500-watt generator.

This rugged submersible pump is loaded with features such as:

- **THERMAL OVERLOAD PROTECTION** - Automatically shuts off the motor should it reach an unsafe operating temperature.
- **HEAVY-DUTY LIFTING HANDLE** - Provides and convenient and safe location to attach a lifting device.
- **STRAIN-RELIEF PROTECTOR** - Provides added safety in the event the operator should try lifting the pump from the electrical cord.
- **REPLACEABLE DISCHARGE PORT** - Provides easy maintenance and lower repair costs.
- **DOUBLE OIL-LUBRICATED SEAL** - provides positive lubrication if the pump should be left running dry. This helps prevent damage in the event the pump is run dry for short periods of time.
- **IMPELLER** - Abrasion resistance plastic minimizes wear and extends impeller life.

- **PUMP CASING** - High strength plastic design makes pump a great choice in corrosive environments. Ideal for use in marine and certain chemical applications.

If the pump was used to pump water containing mud, silt, use clean water to flush out the pump after each use.

DO NOT allow the pump to run dry for an extended period of time, as this will damage the pump. During maintenance, dry running is permissible but only for a few seconds.

NEVER lift the pump by its electrical power cord. **ALWAYS** lift the pump by its carrying handle or attach a rope to the carrying handle.

A pump fully submerged in liquid will not freeze, unless the liquid freezes. **DO NOT** allow a partially submerged pump to freeze. The expansion of water freezing in the volute may crack the pump, causing expensive repairs. If there is any danger of the pump being subjected to freezing temperatures, Lift the pump from water and allow it to drain thoroughly.

If the pump jams or the pump rotor locks for any reason, disconnect the pump from the power source immediately. Allowing the pump motor to cycle **ON** and **OFF** under an overload condition can burn out the motor.

When replacement of nuts and bolts is required, use only recommended parts as referenced in the parts section of this manual. This pump uses metric threads. **DO NOT** use English measurement threads.

COMPONENTS

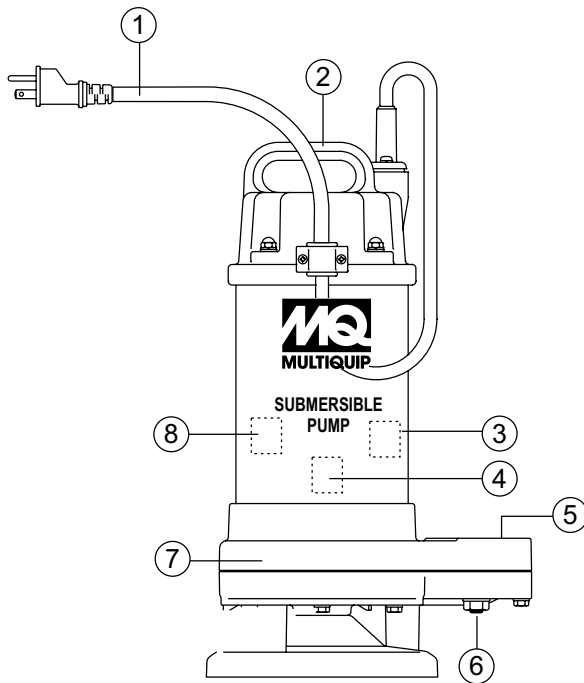

Figure 3. Submersible Pump Components

Figure 3 shows the location of the basic components, for the CX400/PX400 submersible pumps. Listed below is a brief explanation of each component

1. **AC Power Cable** – This unit is supplied with a 19 ft. (approximately 6 m) AC power cable with a grounding-type plug. Always check the cable for signs of wear. **NEVER** use a defective power cable.
2. **Carrying Handle** – Always carry the submersible pump by its handle. **NEVER!** carry the pump by its power cord. Carrying or lifting the pump by the power cord will cause undue stress on the cord and can ultimately dislodge the cord from the pump.
3. **Thermal Overload Protection** – This pump is equipped with a thermal overload protection device that will shut down the motor in the event of high operating temperatures. The motor will automatically restart once the temperature returns to an acceptable operating temperature.
4. **Mechanical Seal** – The hydraulic oil in the pump cavity is designed to provide cooling for the pump seal. This

allows the pump to run dry for a limited period of time

5. **Discharge Port** – Connect a 2-inch hose to this port. Remember to adequately support the discharge hose to avoid stress on the pump.
6. **Mechanical Seal Oil Plug** – Remove this plug to check and add lubrication oil (Paraffin P70 lubricant) to the oil cavity. This oil protects the mechanical seal. Oil cavity should be full enough to cover seal spring.
7. **Volute/Impeller** – Impellers are constructed of abrasion-resistant plastic to minimize wear and prolong service life.
8. **Electric Motor** – These submersible pumps utilize a 60 Hz, single-phase, 115 VAC, 1/2 HP electric motor. Consult with a licensed electrician before connecting motor to a power source and control boxes. Observe all city and local safety codes.

DIRECT POWER OPERATION

Direct Power Operation

The CX400/PX400 submersible pumps can be configured to operate by direct power (Figure 4) or connected to a control box (Figure 10) utilizing float switches. When the pump is connected directly to a 1Ø, 115 VAC, 60 Hz power source, the pump will operate soon as power is applied. It is suggested that a quick disconnect switch be installed as a means of turning the power on and off.

When operating the pump using direct power (no control box), the pump must be monitored at all times. Failure to monitor the pump during operation could lead to **severe pump damage** should the pump encounter problems such as a stuck impeller or not fully immersed in water.

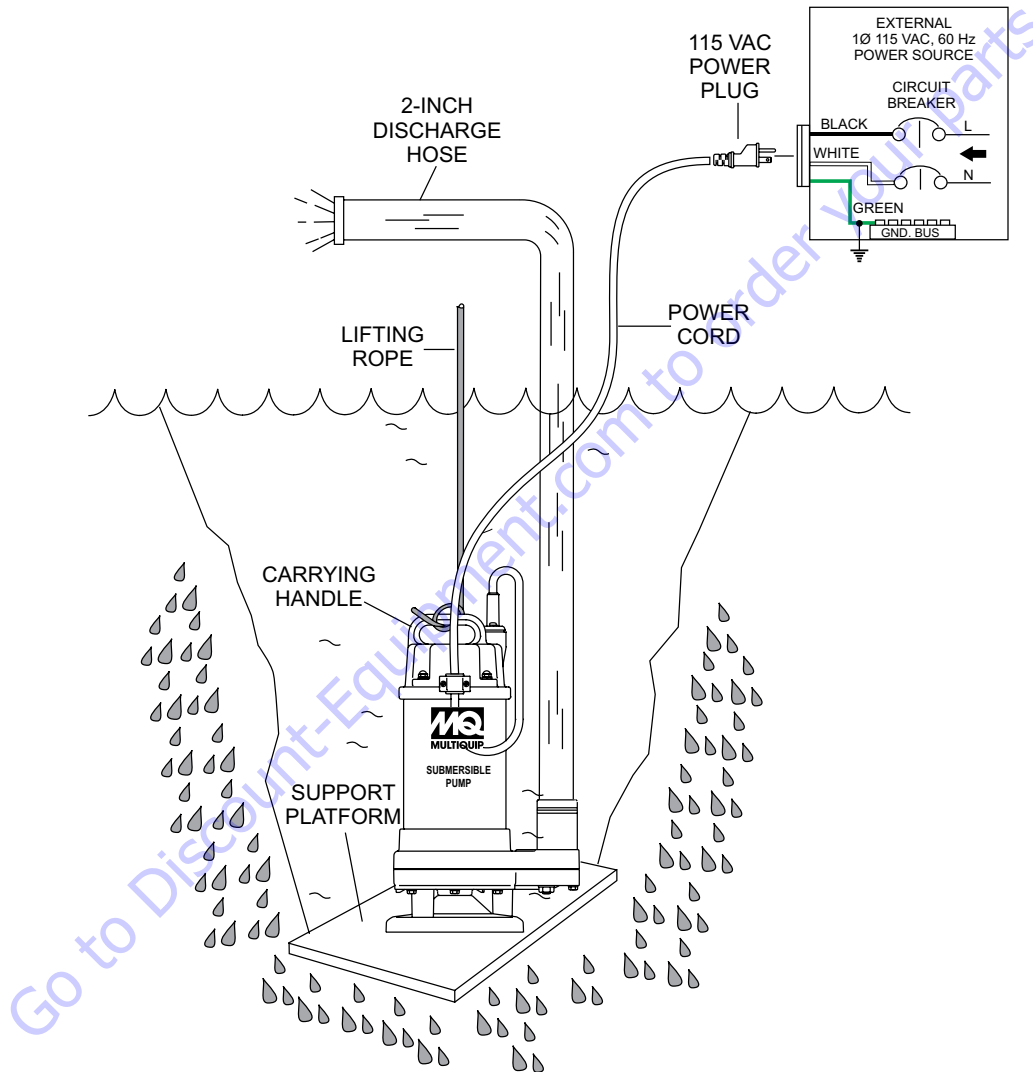

Figure 4. Direct Power Application.

FLOAT SWITCHES

Mechanical Float Switch

Mechanically activated float switches offer a reliable low current control for dewatering applications.

How It Works

The mechanical float switch control will turn ON (close) when the float tips 45° above -horizontal, indicating a high level, and turns OFF (opens) when the float switch drops 45° below horizontal. Reference Figure 6 and Figure 7. Maximum pumping range is 120 degrees. See Figure 5 below.

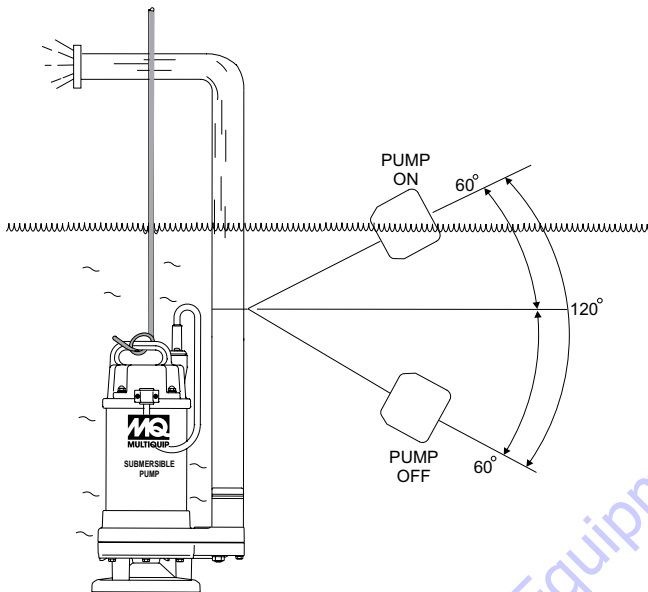

Figure 5. Pumping Range (Float Switch)

Pumping Range

The pumping range of the pump is determined by the float switch tether cord. Use Table 3 as guide line to determine your required pumping range. Pumping ranges are based on non-turbulent conditions. Range may vary due to water temperature and cord shape. Please note as the tether length increases, so does the variance of the pumping range.

Table 3. Pumping Range

Tether Length	2 in. 5.08 cm.	4 in. 10.16 cm.	6 in. 15.24 cm.	8 in. 20.32 cm.	10 in. 25.4 cm.	12 in. 30.48 cm.	14 in. 35.56 cm.	16 in. 40.46 cm.
Pumping Range	6 in. 15.24 cm.	10 in. 25.4 cm.	14 in. 35.56 cm.	18 in. 45.72 cm.	22 in. 55.88 cm.	27 in. 68.58 cm.	31 in. 78.74 cm.	35 in. 88.9 cm.

Design Features

Float switch housings are constructed of high-impact, corrosion resistant polypropylene with mechanically activated, snap action contacts.

- Suitable for most liquid environments.
- Hermetically sealed.
- Thick-walled non-corrosive PVC plastic enclosure.
- Pressure tested to 30 ft. (9 meters).
- Standard SJO, 16-gauge, 2 conductor cord (20 ft./6.09 m).

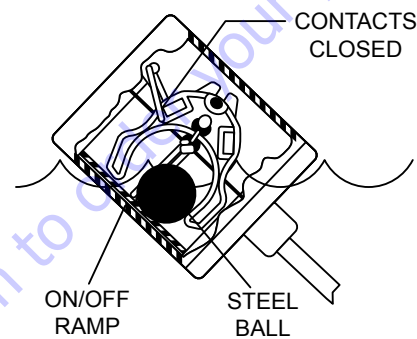

Figure 6. Float Switch (Closed)

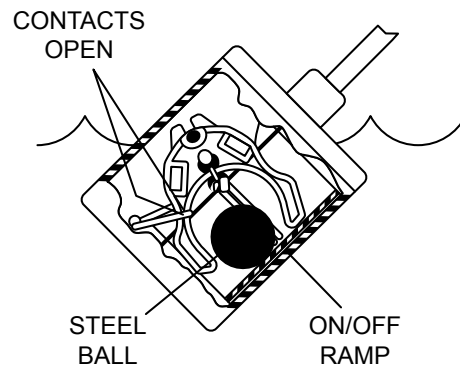

Figure 7. Float Switch (Open)

Float Switches

For unattended operation of the submersible pump two float switch methods can be used single or dual. The single float switch (Model SW1A) will allow the pump to turn on and off depending on the length of the tether. When using the dual float switch (Model SW2A) method the pump will turn on or off at a pre-determined water level. This water level is set by the length of the tether.

Mounting The Float Switches

1. Determine the required **cord tether length** as shown in Figure 5 and Table 3.
2. Place the cord into the clamp as shown in Figure 8 and Figure 9
3. Secure the clamp to the discharge hose as shown in Figure 8. **DO NOT** install cord under hose clamp.
4. Using a screwdriver, tighten the hose clamp. **DO NOT** over-tighten. Make sure the float cord is not allowed to touch the excess hose clamp band during operation.

NOTICE

Single float switch, Model SW1A has a pumping range between 5.5~18 in. (14~46 cm.). Dual float switch has a pumping range between 1~48 in. (2.54~122 cm.)

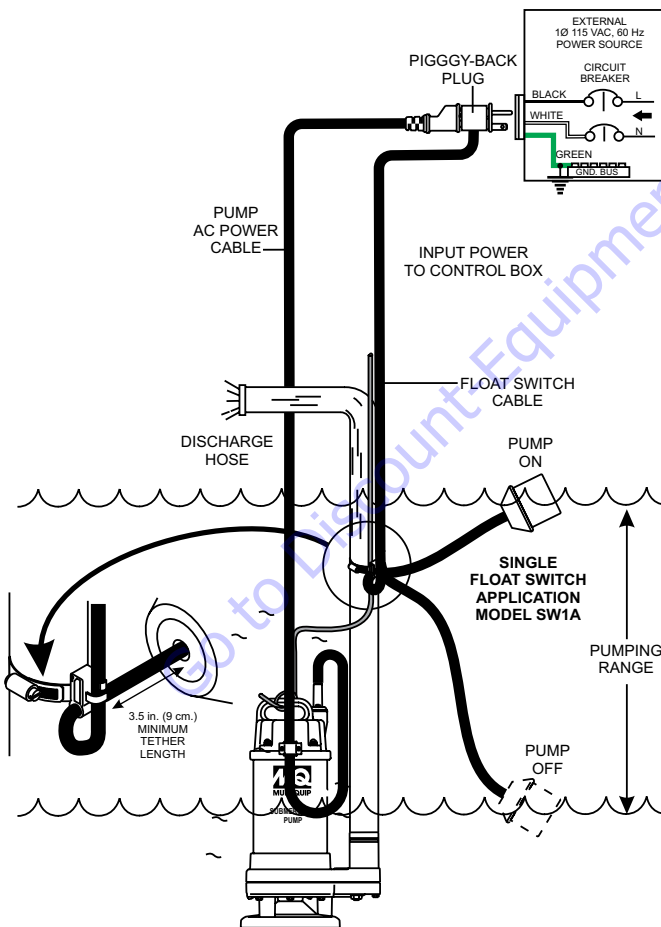

Figure 8. Single Float Switch Application

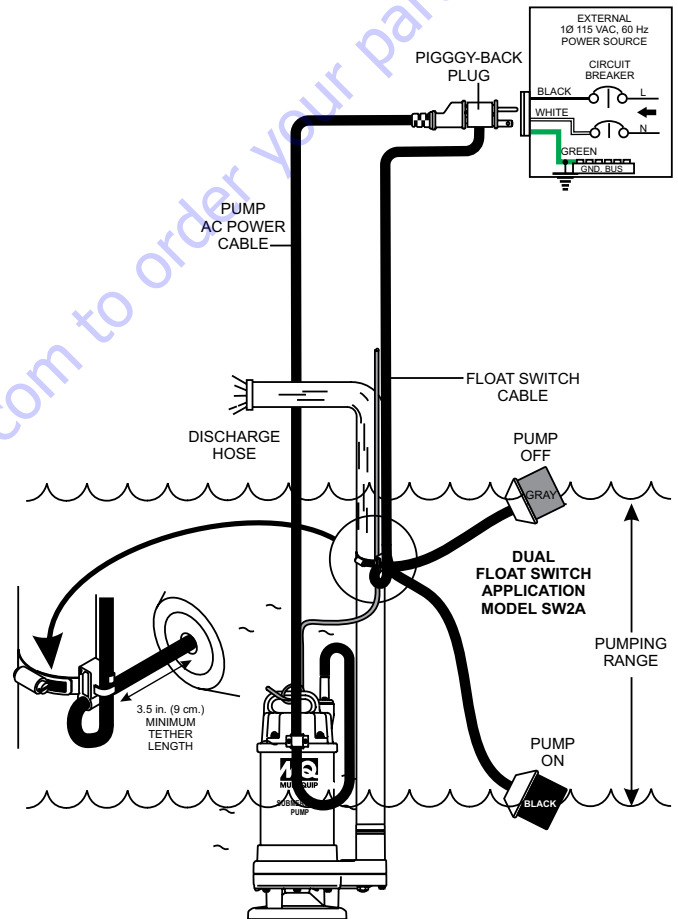

Figure 9. Dual Float Switch Application

FLOAT SWITCHES (CONTROL BOX)

CB3 Control Box

For special remote pumping applications of the submersible pump, a control box (Model CB3) is required. This water resistant control box (Figure 10) provides watertight housing and glands to prevent water from leaking into the box, and a float switch interface. The CB3 control box will require the use of *two* SW-1WOPA float switches, no plug, bare wires for direct connection to the control box. Reference Figure 23 for a schematic representation of the control box.

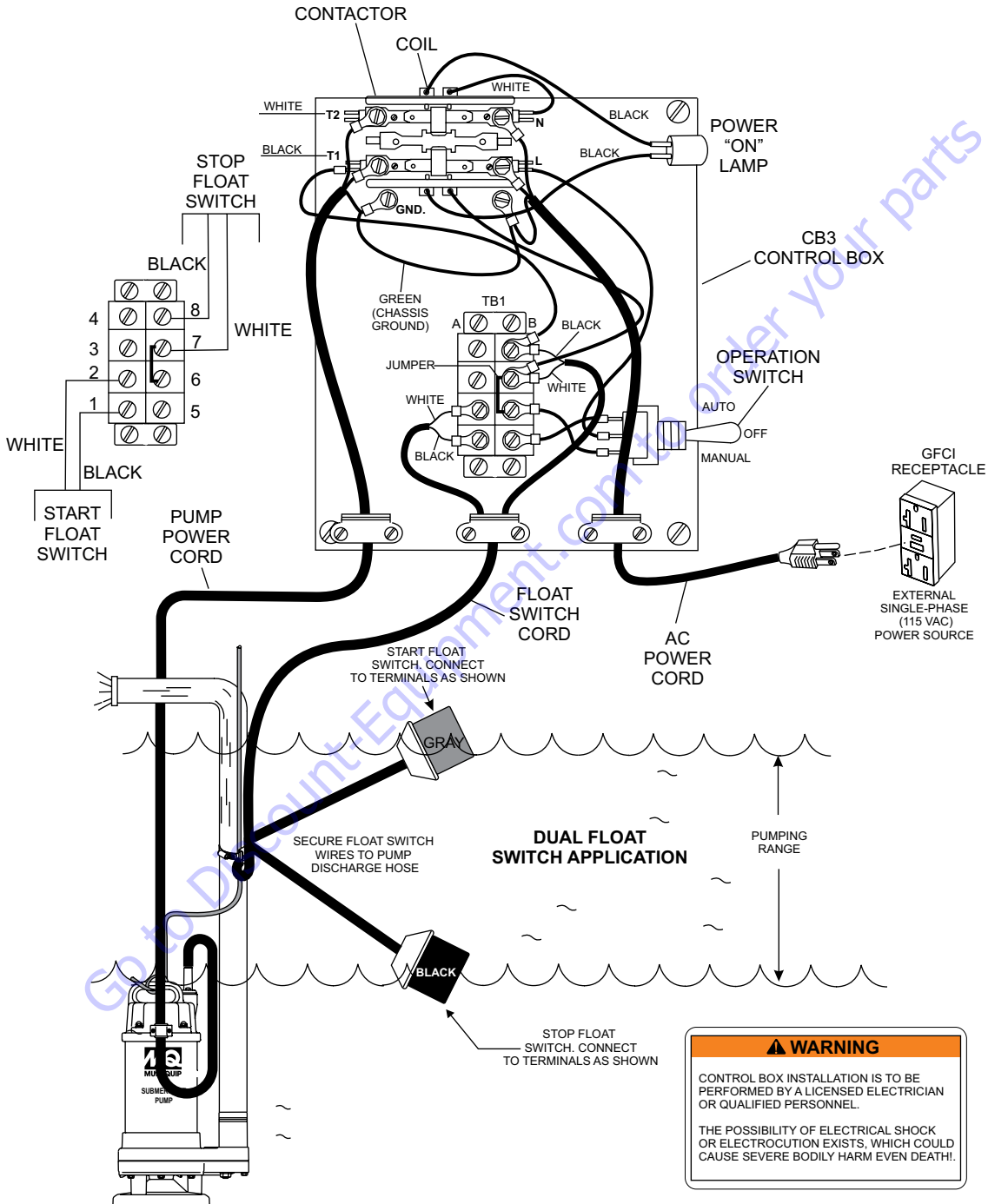

Figure 10. CB3 Control Box Dual Float Switch Application Diagram

Hose Connections

1. Connect a 2-inch hose to the discharge port on the pump as shown in Figure 11. Make sure that hose is attached correctly to the discharge port.

Attaching Lifting Rope

1. Attach a suitable lifting cable (rope) to the carrying handle (Figure 11) on the pump and lower the pump into place. For applications where there is an excessive amount of mud, grit or silt, the use of a support platform is desirable. When pumping water from swimming pool type applications where there is little or no debris, the support platform is not required.

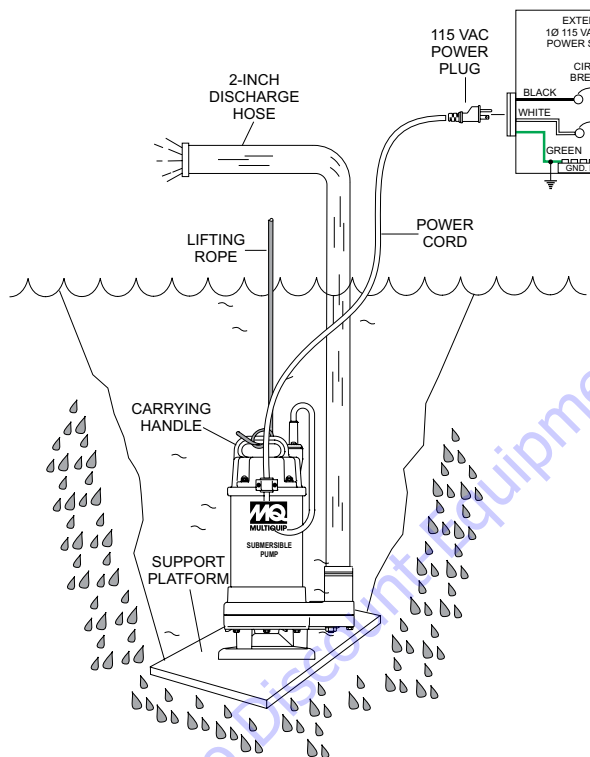

Figure 11. Submersible Pump Upright Position (Correct)

2. Make sure the pump is always placed in an upright position (Figure 11, and not tilted (Figure 12). Never position the pump directly on a soft, loose bottom. Remember to attain maximum pumping capacity and prevent excessive wear. Position the pump so it will not burrow itself into sand or clay.

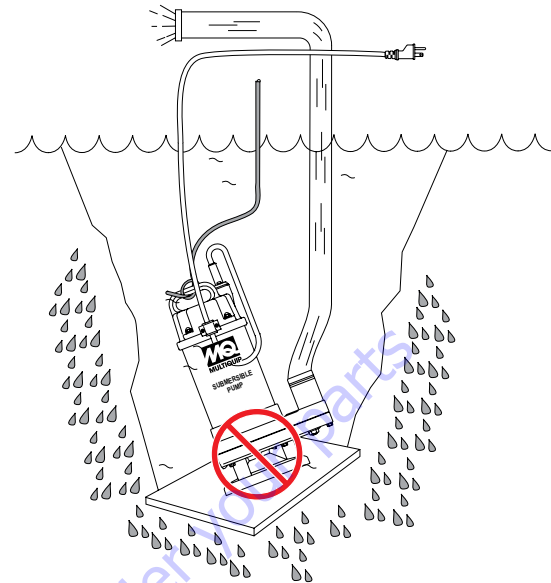

Figure 12. Submersible Pump Tilted Position (Incorrect)

Pump Power Connections (No Control Box)

1. Make sure circuit breaker supplying power to pump motor is in the **OFF** position.
2. Insert the power cable plug (Figure 11) into the appropriate power source receptacle. The correct source voltage for this pump is 115 VAC, 60 Hz, single-phase.
3. If all of the pump's electrical requirements have been met, place the circuit breaker or power ON/OFF switch in the **ON** position.
4. Wait a few seconds and water should begin to flow from the discharge hose.
5. If water is not flowing from the discharge hose or not flowing freely after a few minutes, place the circuit breaker or ON/OFF switch in the **OFF** position and check the system for leaks.

NOTICE

When connecting the pump directly to a power source (no control box), it is recommended that personnel monitor the pump while in operation. Severe pump damage can occur if left unattended.

For unattended operation Multiquip recommends the use of the CB3 control box.

Control Box Installation

The following procedure outlines the steps for connecting the pump to a control box.

⚠ DANGER



The CX400 and PX400 submersible pumps are also designed to work with a control box. This control box contains the necessary electronics (float switch connections) to operate the pump. Remember this control box contains hazardous voltages. Disconnect all sources of power before installing or servicing. There exists the possibility of electrocution, electric shock or burn, which can cause severe bodily harm or even **death!**

⚠ DANGER



When installing the control box, the possibility exists of electrical shock, electrocution and possibly death! **NEVER** have untrained personnel perform the installation. **ALWAYS** have qualified service personnel (licensed electrician) perform the installation.

⚠ WARNING



Explosion or Fire Hazard exists if this pump is used with flammable liquids. **DO NOT** use this pump with **flammable liquids**. **DO NOT** install this pump in hazardous locations as defined by the National Electrical Code, ANSI/NFPA 70.

Control Box Mounting

Mount the control box in an **upright vertical position**. Make sure the control box is securely fastened to a flat surface, that is free of dust, dirt, moisture or any elements that may contaminate or erode the electronic components of the control box.

Single-Phase Power Installation (Input)

The CX400/PX400 submersible pumps require 1Ø, 115 VAC, 60 Hz, power for normal operation.

If you cannot determine what your pump's power requirements are, look at the vendor supplied identification name tag attached to the pump or contact Multiquip's service department.

NOTICE

Applying incorrect power (voltage or voltage phase) to the submersible pump can cause severe damage to the pump motor. Please make sure that the correct voltage and phase are connected to the pump motor at all times.

Power Cord Requirements

When routing the 115 VAC, 60 Hz., single phase power via a power cord to the control box, **ALWAYS** use the correct wire size. Please refer to Table 4 to determine the correct wire size. Incorrect wire size can adversely affect the performance of the pump and may ultimately burn-out the pump motor.

Table 4. Power Cord Length and Wire Size			
AMPS	50 FT. (15.24 m)	100 FT. (30.48 m)	150 FT. (45.72 m)
6	16 AWG	16 AWG	14 AWG
8	16 AWG	14 AWG	12 AWG
10	16 AWG	14 AWG	12 AWG
12	14 AWG	14 AWG	12 AWG
14	14 AWG	12 AWG	10 AWG
16	12 AWG	12 AWG	10 AWG

Connecting Dual float Switch (SW-1WOP) To Control Box

1. Remove the float switch input connector housing, then route the float switch wires through the cable gland on the control box. Attach the wires of the float switch to the terminal block as indicated by Table 5 and Figure 10.

Table 5. Dual Float switch Connections		
Float Switch	Terminal Block No.	Wire Color
Start	TB1-A1	Black
	TB1-A2	White
Stop	TB1-B8	Black
	TB1-B7	White

2. Tighten the connector housing to ensure a tight fit between the cord and the connector body. This will prevent the cable from pulling out of the terminal block and also prevent moisture from entering the control box.
3. Determine the tether length of the float switch wires then secure float switch wires to pump discharge hose. See Figure 8 or Figure 9 and Table 3 to determine the pumping range.

Connecting AC Power to the CB3 Control Box

1. The AC input power cord (not included) should have three wires. Each wire is color coded. The colors are **WHITE, BLACK** and **GREEN**.
2. Remove the AC input connector housing from the control box, then route the power cord through the cable gland on the control box.
3. Connect the AC input power cord to the contactor located inside the control box as shown in Figure 10, and Table 6.

Table 6. 1Ø-115 VAC Power Connections	
Wire Color	Contactor.
BLACK	L1
WHITE	L2
GREEN	GROUND

4. Connect the other end of the AC power cord to the voltage source. Remember to provide a means of disconnecting the power from the control box (circuit breaker or quick disconnect switch). Also make sure to provide a good earth ground to the control box

NOTICE

It is recommended that the power being supplied to the control box **ALWAYS** be connected to a **circuit breaker** or a **quick disconnect switch**. This safety feature allows for quick removal of power from the control box in the event of an emergency.

Connecting AC Power to the Pump Motor

1. AC power is routed to the pump motor via a contactor. The coil of the contactor is energized or de-energized by the opening and closing of the float switch contacts.
2. The power cord (included with pump) should have three wires. Each wire is color coded. The colors are **WHITE, BLACK** and **GREEN**.
3. Remove the pump AC input connector housing from the control box, then route the power cord through the cable gland on the control box.
4. Connect pump power cord to the contactor as shown in Figure 10, and Table 7.

Table 7. AC Output Power Connections To Pump	
Wire Color	CONTRACTOR
BLACK	T1
WHITE	T2
GREEN	Ground

Turning On The Pump

If all of the pump's electrical requirements have been met, place the circuit breaker or power ON/OFF switch in the **ON** position.

The CB3 control box has an operation switch located on the front cover. This switch has 3 positions, **AUTO**, **MANUAL** and **OFF**. The **AUTO** position allows the pump to run in an un-attended mode.

The **MANUAL** position will let the pump run without the float switches controlling the pump. When in the manual mode be careful not to let the pump run dry. Severe damage to the pump may occur if it is allowed to run dry. **NEVER** let the pump run dry.

Manual Operation

1. For manual operation of the pump, place the 3-position operation switch (Figure Figure 13) on the control box in the **MANUAL** position.



MANUAL

Figure 13. Manual-Off-On SW. (Man. Position)

2. The AC power indicator lamp (Figure 14) should be lit (**ON**).



Figure 14. AC Power Indicator Lamp (ON)

3. Wait a few seconds and water should begin to flow from the discharge hose.
4. If water is not flowing from the discharge hose or not flowing freely after a few minutes, remove the power from the pump and check the system for leaks.
5. To stop the pump from pumping, place the operation switch in the **OFF** position.

Automatic Operation

1. For unattended operation of the pump, place the operation switch (Figure 15) in the **AUTO** position.



Figure 15. Manual-Off-On SW. (AUTO Position)

2. In the **AUTO** mode the pump will run as long as there is a sufficient amount of water for the **start float** switch to be activated. This water level is determined by the setting of the float switches.

The **stop float** switch contacts will open when the water level is low and power will be removed from the pump's motor.

3. Once the water level has risen back to the appropriate level the **start float** switch contacts will close and power will be restored to the pump's motor.

Shut-Down

1. Place the 3-position operation switch on the control box in the **OFF** position (Figure 16).



Figure 16. Manual-Off-On SW. (OFF Position)

2. Verify that the control box power ON light is **OFF**.
3. Remove the power from the pump by turning off the circuit breaker or switch that provides power to the pump. Remember to make sure that hands are dry (not wet), and feet are not standing in water when removing or disconnecting power from the pump.
4. Using the lifting rope, lift the pump up from its current position. Remove the discharge hose from the discharge port on the pump.
5. Remove all power cables and float switches from the control box. Place cables and float switches in a suitable container where they will not get damaged.

Cleanup

1. Wipe off any mud or debris that might have attached itself to the pump.
2. If the pump was used to pump mud, grit or silt, flush vigorously with clean water.
3. Store pump in a clean dry place away from dirt and debris.

Lubrication

To check the lubrication oil level of the mechanical seal perform the following:

Checking Lubrication Oil Level (2,000 hours/6 months)

1. Lay pump flat on its side (PX400 only) as shown in Figure 17.

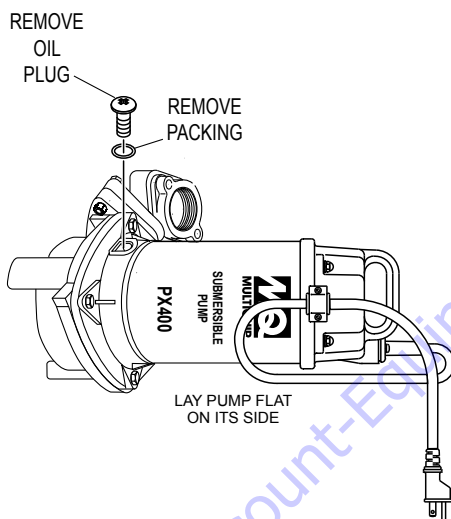

Figure 17. Checking Lubrication Oil Level

2. Using a screwdriver, remove oil plug.
3. Visually inspect oil plug hole to verify that oil cavity is full enough to cover seal spring.
4. When reinstalling oil plug, apply teflon tape to prevent leaking.

NOTICE

Refer to Figure 21 for the location of oil plug. for the CX400 submersible pump. Pump must be disassembled to gain access to oil plug. When adding oil to the CX400 pump, pump must be turned upside down.

Changing Lubrication Oil (4,000 hours/12 months)

1. If lubrication oil level is low, block the oil fill opening with a finger and lay pump on its side (Figure 18) to drain oil into a small container.

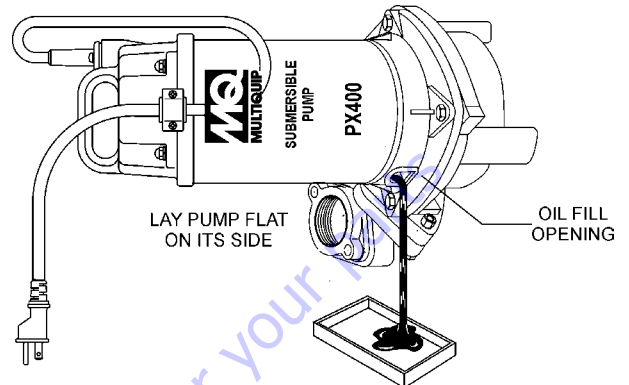

DISCOLORATION OF OIL (MILKY) INDICATES A WORN OR DEFECTIVE MECHANICAL SEAL. REPLACE MECHANICAL SEAL.

Figure 18. Draining Lubrication Oil

2. Use a funnel (Figure 19) and fill oil cavity with Fluid Paraffin P70 lubrication oil or equivalent. Pump oil cavity capacity is 175 cc. Fill to 75-80% capacity to allow for expansion. Replace lubrication oil every 12 months (4,000 hours) or as needed.

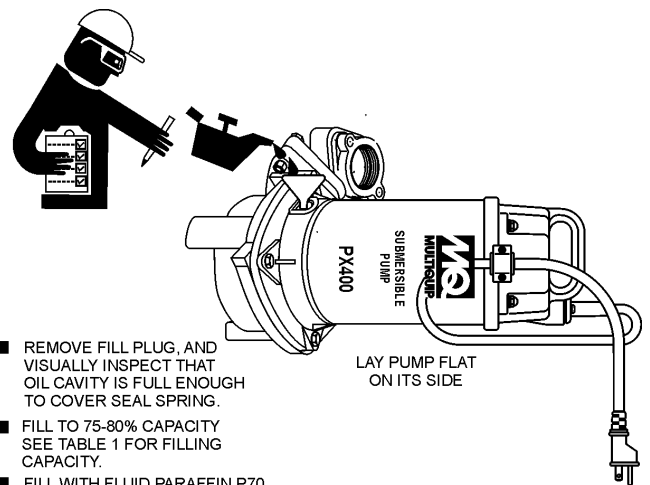

- REMOVE FILL PLUG, AND VISUALLY INSPECT THAT OIL CAVITY IS FULL ENOUGH TO COVER SEAL SPRING.
- FILL TO 75-80% CAPACITY SEE TABLE 1 FOR FILLING CAPACITY.
- FILL WITH FLUID PARAFFIN P70 LUBRICATION OIL, OR EQUIVALENT LUBRICATION OIL.
- CHECK LUBRICATION OIL EVERY 2000 HOURS (6 MONTHS). CHANGE EVERY 4000 (12 MONTHS) OR AS NEEDED.
- DISCOLORATION OF OIL (MILKY) INDICATES A WORN OR DEFECTIVE MECHANICAL SEAL.

Figure 19. Adding Lubrication Oil

Inspecting Lubrication Oil (Mechanical Seal)

1. Block the oil fill opening with a finger and roll pump to one side to drain (Figure 18) oil into a small transparent container.
2. If oil is cloudy (milky) or has water in it, indicates that mechanical seal is defective or worn. Replace **mechanical seal**.

Impeller/Mechanical Seal Replacement (PX400)

Reference the following procedure and Figure 20 for the removal of the impeller and mechanical seal.

1. Remove the 4 bolts, nuts and washers that secure, casing cover to the casing..

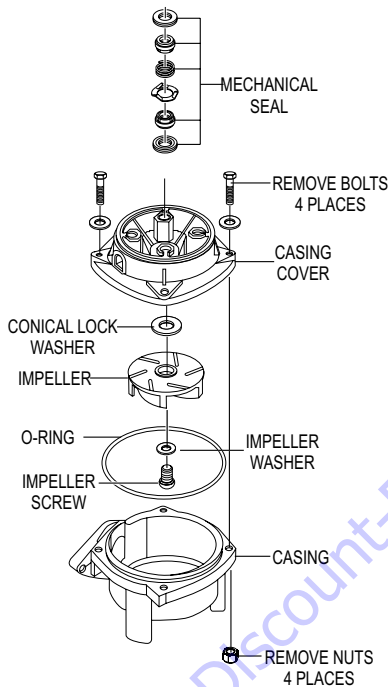

Figure 20. Mechanical Seal Impeller Removal (PX400)

2. Remove any debris that may have accumulated on the impeller.
3. If replacement of the impeller is required, remove impeller screw and washer.
4. Slide mechanical seal from casing cover cavity and replace with new one.
5. Replace o-ring, impeller washer and conical lock washer if necessary.
6. Reassemble in reverse order.

Impeller/Mechanical Seal Replacement (CX400)

Reference the following procedure and Figure 21 for the removal of the impeller and mechanical seal.

1. Remove the bolts securing the casing cover to the casing .

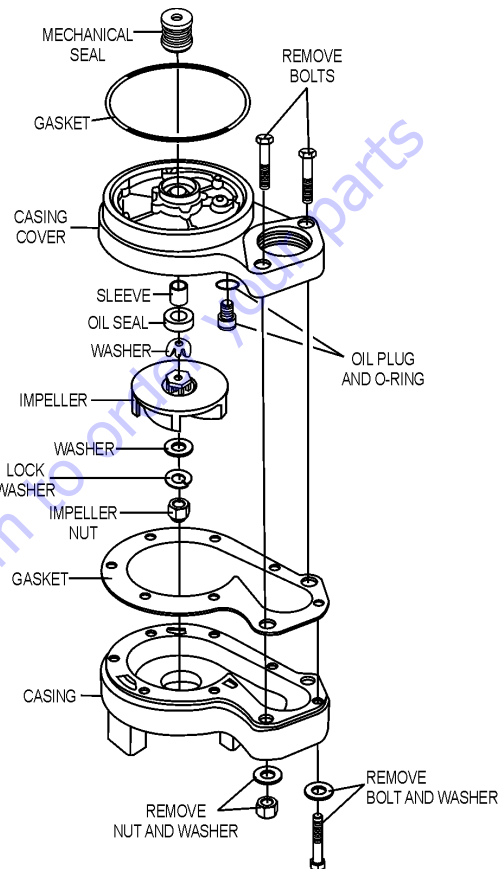

Figure 21. Mechanical Seal Impeller Removal (CX400)

2. Remove any debris that may have accumulated on the impeller.
3. If replacement of the impeller is required, remove impeller nut and washer.
4. Slide mechanical seal from casing cover cavity and replace with new one.
5. Replace o-ring, impeller washer and washers, gaskets, oil seal and any other pump components if necessary.
6. Reassemble in reverse order.

Electrical Insulation Testing

Why perform electrical insulation testing?

Electrical insulation starts to age as soon as it's made. Harsh environments, especially those with extreme temperature changes and/or chemical contamination, cause further deterioration of the insulation (power cord).

As a result, personnel safety (electrocution/shock) and power reliability can suffer resulting in higher operating cost and maintenance.

What is Insulation Resistance Testing

Insulation resistance testing applies a regulated stabilized high voltage (Figure 22), typically 500 VDC or greater across a dielectric (power cord). Measuring the amount of **leakage current** flowing through the dielectric will yield a resistive measurement in megohms.

Insulating Material Testing

To verify the integrity of the pump's insulating material (power cable) it will be necessary to perform an electrical insulation test. Any electrical insulation must have the opposite characteristic as the conductor: it should resist the flow of current, keeping it within the conductor.

To measure the IR (current x resistance), the use of an IR tester must be employed. This IR tester is a portable device that is a resistance meter (ohmmeter) with a built in DC generator that develops a high DC voltage.

The high DC voltage from the IR tester is usually 500 VDC or more. This voltage, when applied causes a small current to flow through and over the insulation's surfaces. The tester provides a direct reading of IR in megohms.

A high resistance reading would indicate a "**good**" insulation, meaning very little current is escaping through the insulation. While a relatively low resistance reading would indicate **poor** insulation, meaning a significant amount of current may be leaking through and along the insulation.

NOTICE

Insulation resistance is moisture and temperature sensitive. When temperature increases, insulation resistance decreases, and vice versa.

When performing this test measurement, perform the test using the same test parameters as used in the initial testing.

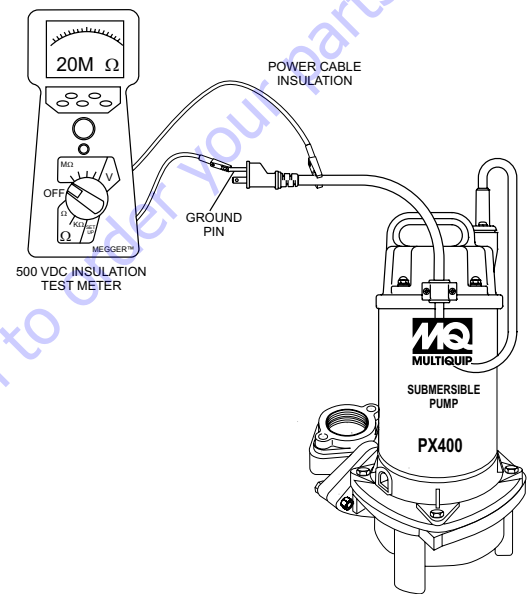

Figure 22. Insulation Tester Application

⚠ DANGER

 Read and follow the manufacturer's users manual prior to operating insulation tester (megaohm meter). This meter generates a test voltage of 500 volts or greater. Only qualified and trained personnel should use this equipment. The possibility exists of severe **electrical shock, electrocution even death!**, when using insulation tester.

Table 8. Pump Troubleshooting

SYMPTOM	POSSIBLE PROBLEM	SOLUTION
Pump Fails To Start	Incorrect voltage/amps?	Check that proper voltage (115 VAC, 60 Hz, single-phase) is being supplied to the pump. Also check that there is an adequate amount of current (amps) to run the pump. Check power source circuit breaker.
	Check electrical connections?	If using float switches check wiring, inspect power cord.
	Blown power fuse or tripped circuit breaker?	Replace fuse check circuit breaker, check cause of blown fuse or tripped breaker.
	Impeller locked?	Disconnect power cord and check for clogging. Unclog pump. Check overload protection device.
	Wet motor windings?	Use multimeter to check motor insulation. Insulation resistance must be approximately 15 megaohms. If resistance is low, disassemble pump motor and bake windings to dry them.
	Defective motor and pump bearings?	Check for excessive bearing wear, if worn replace bearings. Replace motor if defective.
Pump Fails to Deliver Full Output	Twisted or restricted discharge hose?	Lay hose flat un-kinked. Remove clog from hose line.
	Clogged impeller?	Clean impeller.
	Low voltage?	Use a voltmeter to check voltage while pump is energized. Voltage must be within $\pm 10\%$. Check power source (no load and load). If an extension cord is used, make sure it has adequate current-carrying capacity for the required length. See Table 4.
	Impeller worn?	Replace impeller.
Water in Mechanical Seal Oil	Defective mechanical seal?	Replace mechanical seal.
	Loose Oil Fill Plug?	Tighten securely. Apply teflon tape.

CB3 CONTROL BOX WIRING DIAGRAM

115 VAC, 60 Hz. ELECTRIC MOTOR WIRING DIAGRAM

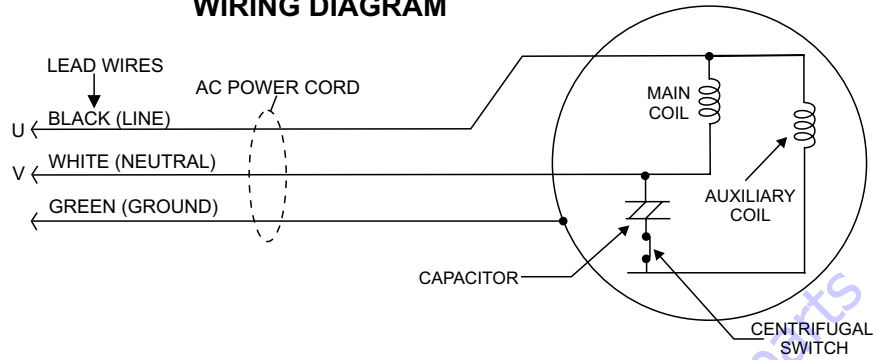

CB3 CONTROL BOX WIRING DIAGRAM

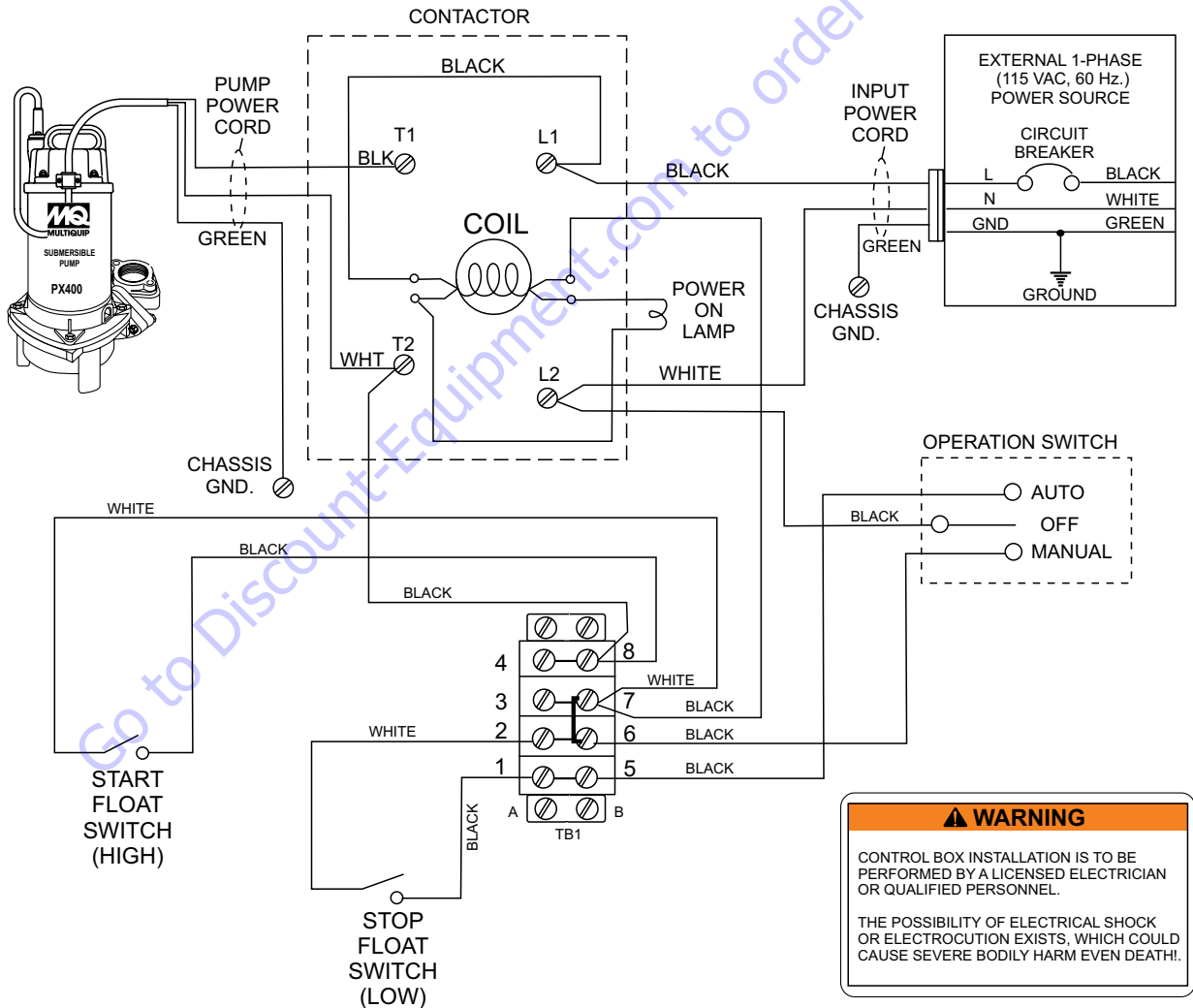

Figure 23. CB3 Wiring Diagram

EXPLANATION OF CODE IN REMARKS COLUMN

The following section explains the different symbols and remarks used in the Parts section of this manual. Use the help numbers found on the back page of the manual if there are any questions.

NOTICE

The contents and part numbers listed in the parts section are subject to change **without notice**. Multiquip does not guarantee the availability of the parts listed.

SAMPLE PARTS LIST

NO.	PART NO.	PART NAME	QTY.	REMARKS
1	12345	BOLT	1	INCLUDES ITEMS W/%
2%		WASHER, 1/4 IN.		NOT SOLD SEPARATELY
2%	12347	WASHER, 3/8 IN. ...	1	MQ-45T ONLY
3	12348	HOSE	A/R	MAKE LOCALLY
4	12349	BEARING	1	S/N 2345B AND ABOVE

NO. Column

Unique Symbols — All items with same unique symbol (@, #, +, %, or >) in the number column belong to the same assembly or kit, which is indicated by a note in the “Remarks” column.

Duplicate Item Numbers — Duplicate numbers indicate multiple part numbers, which are in effect for the same general item, such as different size saw blade guards in use or a part that has been updated on newer versions of the same machine.

NOTICE

When ordering a part that has more than one item number listed, check the remarks column for help in determining the proper part to order.

PART NO. Column

Numbers Used — Part numbers can be indicated by a number, a blank entry, or TBD.

TBD (To Be Determined) is generally used to show a part that has not been assigned a formal part number at the time of publication.

A blank entry generally indicates that the item is not sold separately or is not sold by Multiquip. Other entries will be clarified in the “Remarks” Column.

QTY. Column

Numbers Used — Item quantity can be indicated by a number, a blank entry, or A/R.

A/R (As Required) is generally used for hoses or other parts that are sold in bulk and cut to length.

A blank entry generally indicates that the item is not sold separately. Other entries will be clarified in the “Remarks” Column.

REMARKS Column

Some of the most common notes found in the “Remarks” Column are listed below. Other additional notes needed to describe the item can also be shown.

Assembly/Kit — All items on the parts list with the same unique symbol will be included when this item is purchased.

Indicated by:

“INCLUDES ITEMS W/(unique symbol)”

Serial Number Break — Used to list an effective serial number range where a particular part is used.

Indicated by:

“S/N XXXXX AND BELOW”

“S/N XXXX AND ABOVE”

“S/N XXXX TO S/N XXX”

Specific Model Number Use — Indicates that the part is used only with the specific model number or model number variant listed. It can also be used to show a part is NOT used on a specific model or model number variant.

Indicated by:

“XXXXX ONLY”

“NOT USED ON XXXX”

“Make/Obtain Locally” — Indicates that the part can be purchased at any hardware shop or made out of available items. Examples include battery cables, shims, and certain washers and nuts.

“Not Sold Separately” — Indicates that an item cannot be purchased as a separate item and is either part of an assembly/kit that can be purchased, or is not available for sale through Multiquip.

SUGGESTED SPARE PARTS

CX400/PX400 SUBMERSIBLE PUMPS

1 TO 3 UNITS

Qty.	P/N	Description
1020CX400120.....	AC CORD WITH GLAND CX400
1020CX400060.....	MECHANICAL SEAL CX400
1020PX400120.....	AC CORD WITH GLAND PX400
1020PX400060.....	MECHANICAL SEAL PX400

NOTICE

Part numbers on this Suggested Spare Parts list may supersede/replace the part numbers shown in the following parts lists.

Go to Discount-Equipment.com to order your parts

CX400 PUMP ASSY.

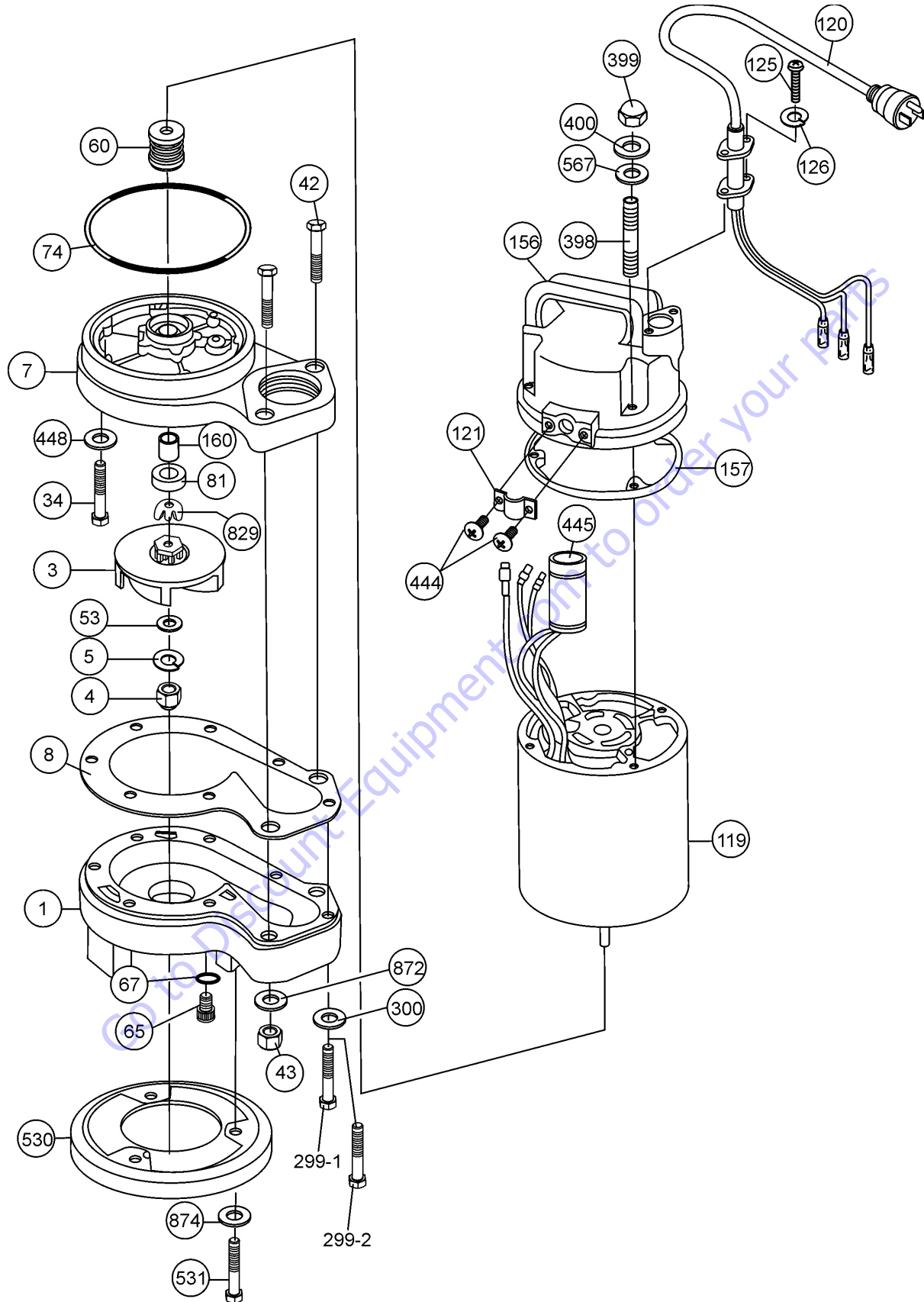

CX400 PUMP ASSY.

<u>NO.</u>	<u>PART NO.</u>	<u>PART NAME</u>	<u>QTY.</u>	<u>REMARKS</u>
1	020CX400001	CASING	1	
3	020CX400003	IMPELLER	1	
4	020CX400004	IMPELLER NUT	1	
5	020CX400005	WASHER, LOCK	1	
7	020CX400007	CASING COVER	1	
8	020CX400008	CASING PACKING	1	
34	020CX400034	SCREW	3	
42	020CX400042	BOLT	2	
43	020CX400043	NUT	2	
53	020CX400043	LOCK WASHER	1	
60	020CX400060	MECHANICAL SEAL	1	
65	020CX400065	OIL PLUG SCREW	1	
67	020CX400067	O-RING	1	
74	020CX400074	CASING COVER PACKING	1	
81	020CX400081	OIL SEAL	1	
119	020CX400119	MOTOR	1	
120	020CX400120	AC CORD	1	
121	020CX400121	BAND	1	
125	020CX400125	SCREW	4	
126	020CX400126	WASHER, LOCK	2	
156	020CX400156	HEAD COVER	1	
157	020CX400157	HEAD COVER PACKING	1	
160	020CX400160	SLEEVE	1	
299-1	020CX400299A	BOLT	5	
299-2	020CX400299B	BOLT	2	
300	020CX400300	WASHER, FLAT	7	
398	020CX400398	STUD BOLT	4	
399	020CX400399	NUT	4	
400	020CX400400	WASHER	4	
444	020CX400444	SCREW	2	
445	020CX400445	CAPACITOR	1	
448	020CX400448	PACKING	6	
530	020CX400530	BOTTOM PLATE	1	
531	020CX400531	BOLT	3	
567	020CX400567	WASHER, FLAT	4	
829	020CX400829	WASHER	2	
872	020CX400872	WASHER, FLAT	2	
874	020CX400874	WASHER, FLAT	3	

PX400 PUMP ASSY.

<u>NO.</u>	<u>PART NO.</u>	<u>PART NAME</u>	<u>QTY.</u>	<u>REMARKS</u>
1	020PX400001	CASING	1	
3	020PX400003	IMPELLER	1	
7	020PX400007	CASING COVER	1	
8	020PX400008	O-RING	1	
23	0020PX40023	COMPANION FLANGE	1	
24	020PX400024	PACKING	1	
34	020PX400034	SCREW	4	
42	020PX400042	BOLT	2	
43	020PX400043	NUT	2	
53	020PX400053	WASHER	1	
60	020PX400060	MECHANICAL SEAL	1	
65	020PX400065	OIL PLUG SCREW	1	
67	020PX400067	PACKING	1	
74	020PX400074	PACKING	1	
102	020PX400102	DISCHARGE PORT	1	
103	020PX400103	PACKING	1	
104	020PX400104	BOLT	2	
106	020PX400106	CUSHION, RUBBER	4	
107	020PX400107	SCREW	4	
119	020PX400119	MOTOR	1	
120	020PX400120	AC CORD	1	
125	020PX400125	SCREW	2	
260	020PX400260	WASHER, LOCK	2	
263	020PX400263	WASHER	2	
299	020PX400299	BOLT	4	
300	020PX400300	WASHER	4	
321	020PX400321	NUT	4	
333	020PX400333	SCREW	1	
431	020PX400431	NUT	2	
448	020PX400448	O-RING	4	
829	020PX400829	CONICAL LOCK WASHER	1	
872	020PX400872	WASHER	2	
918	020PX400918	STIR IMPELLER	1	

OPERATION AND PARTS MANUAL

HERE'S HOW TO GET HELP

PLEASE HAVE THE MODEL AND SERIAL
NUMBER ON-HAND WHEN CALLING

Go to Discount-Equipment.com to order your parts

Your Local Dealer is:



www.Discount-Equipment.com

