



REVISED STARTING
SERIAL #071110368

PARTS LIST MANUAL

MODEL TMC7



**MODEL
TMC7-5.5H
SHOWN**



**MODEL
TMC7-2L
SHOWN**

7" TURBO EDGE/COMBO GRINDER

SKU NO.	MODEL	POWER OPTION
57100	TMC7-5.5H	HONDA ENGINE MODEL GXV160 w/ DUAL ELEMENT AIR CLEANER
57200	TMC7-2L	LEESON MOTOR 2 HP-1PH-60HZ-115/208-230V-18.4/9.2 FLA



A Division of Equipment Development Company, Inc.

PARTS FINDER

**Search Website
by Part Number**



**Search Manual
Library For Parts
Manual & Lookup Part
Numbers – Purchase
or Request Quote**

Search Manuals

Enter your information to help us find the right parts manual for your machine.

* Brand:

* Model:

* Serial:

* Part Number:

SEARCH

**Can't Find Part or
Manual? Request Help
by Manufacturer,
Model & Description**

Parts Order Form

Please fill in the following information to help us find the right part for your machine.

Manufacturer:	<input type="text"/>
Model:	<input type="text"/>
Description:	<input type="text"/>
Part Number:	<input type="text"/>
Quantity:	<input type="text"/>
Notes:	<input type="text"/>

REQUEST HELP

Discount-Equipment.com is your online resource for quality parts & equipment.

Florida: **561-964-4949** Outside Florida TOLL FREE: **877-690-3101**

Need parts?

Click on this link: <http://www.discount-equipment.com/category/5443-parts/> and choose one of the options to help get the right parts and equipment you are looking for. Please have the machine model and serial number available in order to help us get you the correct parts. If you don't find the part on the website or on one of the online manuals, please fill out the request form and one of our experienced staff members will get back to you with a quote for the right part that your machine needs.

We sell worldwide for the brands: Genie, Terex, JLG, MultiQuip, Mikasa, Essick, Whiteman, Mayco, Toro Stone, Diamond Products, Generac Magnum, Airman, Haulotte, Barreto, Power Blanket, Nifty Lift, Atlas Copco, Chicago Pneumatic, Allmand, Miller Curber, Skyjack, Lull, Skytrak, Tsurumi, Husquvarna Target, Stow, Wacker, Sakai, Mi-T-M, Sullair, Basic, Dynapac, MBW, Weber, Bartell, Bennar Newman, Haulotte, Ditch Runner, Menegotti, Morrison, Contec, Buddy, Crown, Edco, Wyco, Bomag, Laymor, EZ Trench, Bil-Jax, F.S. Curtis, Gehl Pavers, Heli, Honda, ICS/PowerGrit, IHI, Partner, Imer, Clipper, MMD, Koshin, Rice, CH&E, General Equipment, Amida, Coleman, NAC, Gradall, Square Shooter, Kent, Stanley, Tamco, Toku, Hatz, Kohler, Robin, Wisconsin, Northrock, Oztec, Toker TK, Rol-Air, APT, Wylie, Ingersoll Rand / Doosan, Innovatech, Con X, Ammann, Mecalac, Makinex, Smith Surface Prep, Small Line, Wanco, Yanmar

READ AND UNDERSTAND THE OPERATORS INSTRUCTION MANUAL THOROUGHLY BEFORE ATTEMPTING TO OPERATE THIS EQUIPMENT. Death or serious injury could occur if this machine is used improperly.



SAFETY MESSAGES



The safety instructions are preceded by a graphic alert message of DANGER, WARNING, or CAUTION.



Indicates an imminent hazard which, if not avoided, will result in death or serious injury.



Indicates an imminent hazard which, if not avoided, can result in death or serious injury.



Indicates hazards which, if not avoided, could result in serious injury and or damage to the equipment.

GASOLINE Powered Equipment



- Do not operate gasoline powered equipment without adequate ventilation. Carbon monoxide is an invisible, odorless gas that can kill.

ELECTRICAL Powered Equipment



- ELECTRICAL HAZARD** - Be sure equipment is properly grounded. Failure to comply could kill or result in serious injury.



The engine exhaust from this product contains chemicals known to the State of California to cause cancer, birth defects or other reproductive harm.

GENERAL INSTRUCTIONS



- You must read and understand the operators instruction manual and all other manuals associated with this machine. For your safety and the safety of others around you, it is extremely important to fully understand how to operate this machine in the way it was intended. Different model machines or older/newer versions of the same model may have different parts and controls that you need to understand. If instructions are not readable or available DO NOT USE this machine and contact Discount-equipment for a replacement Manual.
- You must be able to physically handle the bulk weight and power of this machine. If not properly controlled this machine can cause death or serious injury.
- Do not operate this machine in an impaired mental state. You must be able to exercise good judgement and reactions to maintain a safe working environment.
- This is a "one person" machine which means only one operator can be operating the machine at any one time. For the safety of others, maintain a safe operating distance to other personnel. Your work area should be defined and appropriately marked so bystanders and coworkers do not stand or walk near this machine and end up seriously injured by flying debris or exposing them to harmful noise or dust.
- This equipment is for Commercial use. Although this is a "one person" machine your work team should understand how to shut this machine off and quickly get medical help if an accident strikes the operator.
- Keep all guards in place during operation. The guards are to provide protection from inadvertent contact with dangerous moving parts, pinch points, or hot surfaces.
- Wear appropriate Personal Protective Equipment (PPE) including safety glasses, safety boots, work gloves, respiratory protection, hearing protection, and head protection. Do not wear loose clothing that can get tangled in moving parts. Failure to do so could result

in dismemberment or death. **Wear an approved respirator when removing hazardous materials or when grinding/cutting dry materials. Some dust particles such as concrete dust can contain silicate particles which can cause silicosis (a very serious lung disease). Contact NIOSH or OSHA for further details. When wet grinding/cutting, avoid contact with the concrete/asphalt slurry which can cause serious skin irritations.**

- You must maintain this machine per the maintenance schedule in the operator manual. Remember before adjusting, servicing, or fueling this machine, disconnect the source of power to the machine by disconnecting the spark plug (Gas models), or by unplugging the electrical power cord (electric models) or air hose (Pneumatic models) AT THE MACHINE so you can assure yourself it remains unplugged while you are working on it. Do not modify this machine. Use only genuine EDCO parts and accessories. Repairs and service should be performed by approved EDCO dealers or authorized technicians.
- You should look carefully around the area before you begin work so you can identify potential hazards such as deck inserts, pipes, columns, openings, electrical cords or outlets, or any other objects protruding from the slab surface.
- This machine has no brain so you must use your own. There is no substitute for safety. The safety decals on the machine are to serve as a reminder for information you must already know before you begin using this machine. Take a moment to reread the safety decals each time you use the machine. If your machine is missing any decals, contact Discount-equipment for a replacement.

PARTS LIST MANUAL

MODEL TMC7

<u>Section</u>	<u>Page Number</u>
Safety Messages and General Instructions	2
How To Order Replacement Parts	3
Illustration 1: Main Grouping	4,5
Illustration 2: Engine Grouping	6,7
Illustration 3: Motor Grouping	8,9
Illustration 4: Rigid Head Assembly	10
Illustration 5: Flex Head Assembly	11
Illustration 6: Optional Scarifier Disc Assembly	12
Page Left Blank Intentionally	13
Wiring Diagram for Electric Motor - Leeson 120867 2HP-1PH-60HZ-115/208-230V	14
Wiring Diagram for Lovato Rotary Cam Switch	15
Limited Equipment Warranty of Sale	Back Page



ILLUSTRATION 1 : MAIN GROUPING

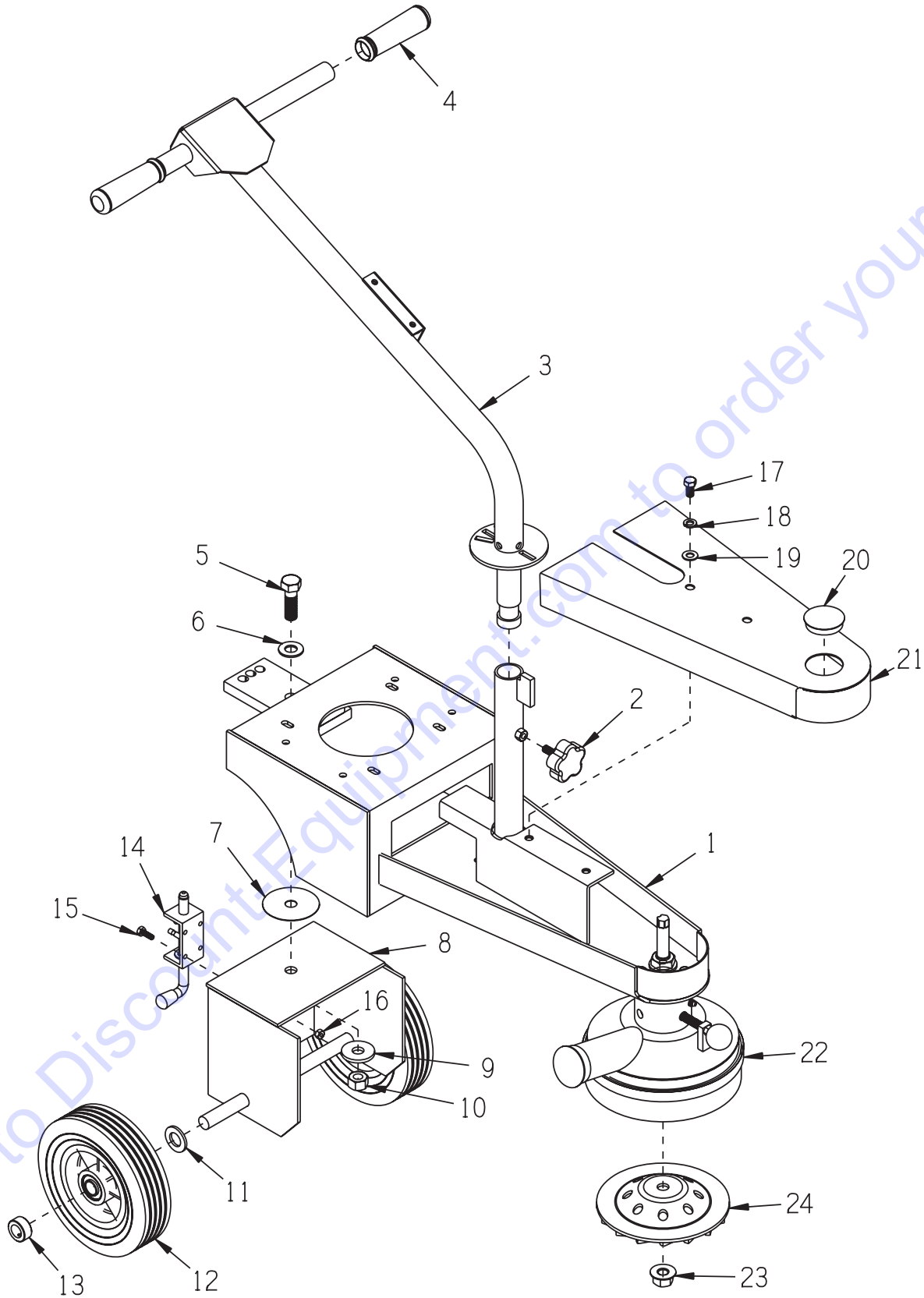

PARTS LISTING - ILLUSTRATION 1: MAIN GROUPING			
ITEM #	PART #	DESCRIPTION	QTY.
1	72301	MAIN FRAME	1
2	51230	KNOB, STAR CLAMPING 3/8-16 X 1"STUD	1
3	72305	HANDLE BAR	1
4	10608	GRIP, HAND 1" MODEL AT	2
	10350	SCREW, CAP 5/8-11 X 2	1
6	10073	WASHER, FLAT 5/8 SAE	1
7	72309	WASHER, DELRIN 3 X 5/8 X 1/32	1
8	72302	CHASSIS, WHEEL	1
9	72303	WASHER, WHEEL CHASSIS	1
10	11707	NUT, HEX NYLON LOCK 5/8-11	1
11	10009	WASHER, FLAT 3/4 SAE	2
12	79013	WHEEL 8 X 2-1/2 X 3/4"BRG.	2
13	10428	COLLAR, LOCKING 3/4"ID	2
14	72304	LATCH, SPRING 1/2" SNAP LOCK	1
15	11634	SCREW, CAP M6 X 1.0P X 20MM	4
16	28026	NUT, HEX NYLON LOCK M6 X 1MM	4
17	10907	SCREW, CAP 3/8-16 X 3/4	2
18	10811	WASHER, LOCK 3/8	2
19	10025	WASHER, FLAT 3/8 SAE	2
20	65022	PLUG, HOLE 2"	1
21	72306	COVER, BELT	1
22		HEAD ASSEMBLY W/ COVER (SEE ILLUS. 4 & 5 FOR BREAKDOWNS)	1
	72312	RIGID HEAD ASSY. (STD. ON GASOLINE MODEL)	
	72313	FLEX HEAD ASSY. (STD. ON ELECTRIC MODEL)	
23	72021	NUT, FLANGE 5/8-11 (INCLUDED W/ HEAD ASSEMBLY)	1
24		7" DIAMOND CUP WHEEL, CONCRETE DRY GRINDING 5/8" ARBOR W/ PIN HOLE	1
	72030	STANDARD GRINDING WHEEL 40-50 GRIT	
	72031	OPTIONAL GRINDING WHEEL 150 GRIT (SEE ILLUS. 6 FOR OPTIONAL SCARIFIER DISC ASSY.)	



A Division of Equipment Development Company, Inc.

ILLUSTRATION 2: ENGINE GROUPING

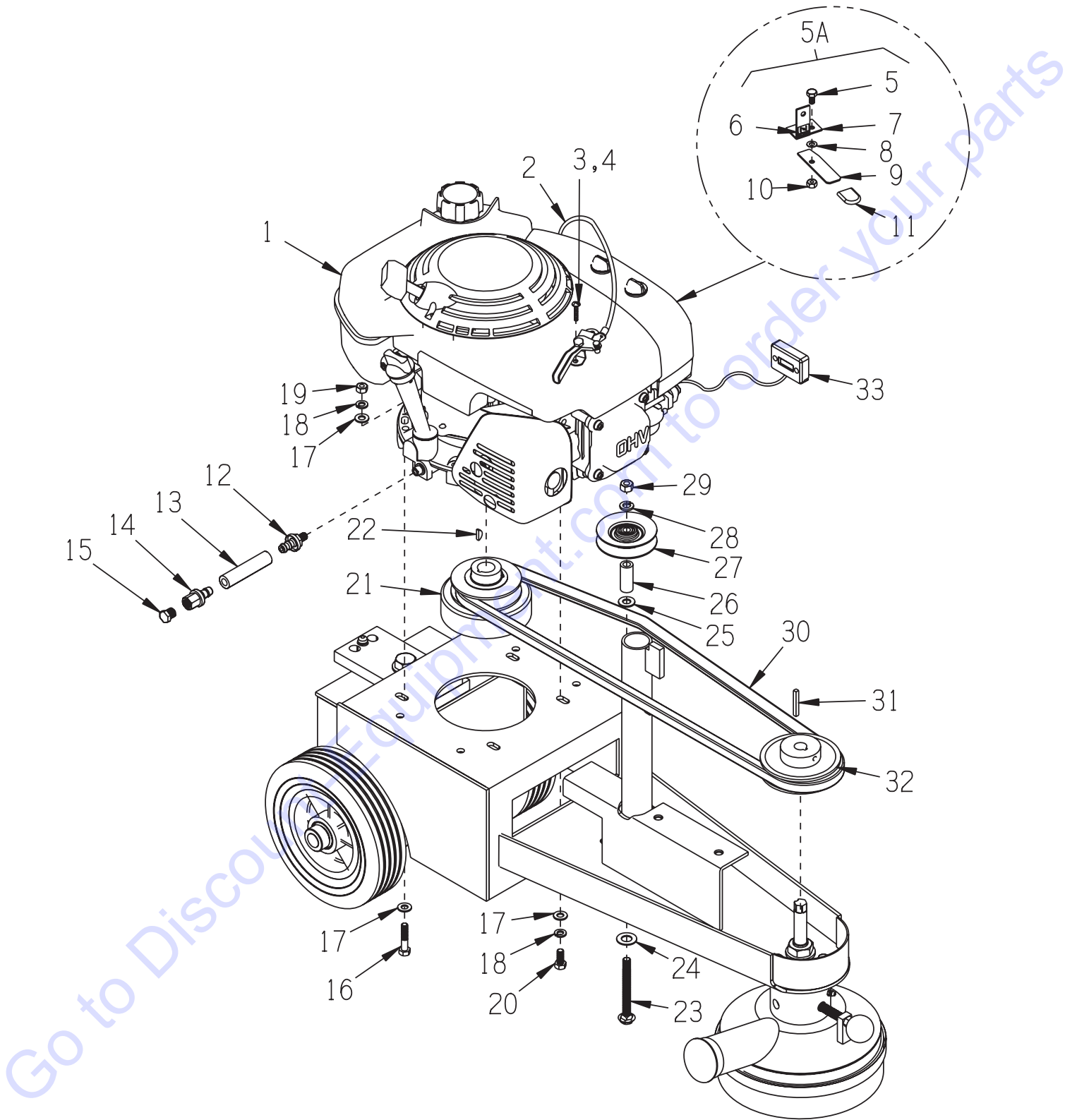

PARTS LISTING - ILLUSTRATION 2: ENGINE GROUPING			
ITEM #	PART #	DESCRIPTION	QTY.
1	76020	ENGINE, HONDA GXV160 w/ D.E.A.C.	1
2	40388	CABLE, THROTTLE, LEVER-TYPE 24"	1
3	10830	SCREW, MACHINE 10-32 X 1/2	2
4	10832	NUT, KEPS 10-32 (NOT SHOWN)	2
5A	15180	MANUAL CHOKE KIT, HONDA GXV160 (INCLUDES 5-11)	-
5	10834	SCREW, CAP 1/4-20 X 1/2	1
6	91301	DECAL, CHOKE 5/8 X 5/8	1
7	15182	BRKT., CHOKE CONTROL, GXV160	1
8	15186	WASHER, BELLEVILLE .500 X.255 X.018	1
9	15181	LEVER, CHOKE CONTROL, GXV160	1
10	10150	NUT, HEX NYLON LOCK 1/4-20	1
11	15184	CAP, FLAT RED .062 X .75 X 1	1
12	11541	BARB, PUSH-ON 3/8 HOSE X 10MM X 1.25	1
13	56116	HOSE, PUSH-ON 3/8"ID X 3"L	1
14	11544	BARB, PUSH-ON 3/8HOSE X 1/4FPT	1
15	10776	PIPE PLUG 1/4NPT (BRASS)	1
16	10204	SCREW, CAP 5/16-18 X 1-3/4	1
17	10213	WASHER, FLAT 5/16 SAE	5
18	10801	WASHER, LOCK 5/16	4
19	10054	NUT 5/16-18	1
20	10048	SCREW, CAP 5/16-24 X 3/4	3
21	77024	CLUTCH, CENTRIFUGAL 3.5 X 1GR X 7/8	1
22	10019	KEY, WOODRUFF 5/32 X 5/8 (#505)	1
23	10910	BOLT, CARRIAGE 3/8-16 X 4" F.T.	1
24	10040	WASHER, GARRET 17/32 X 1 X .054	1
25	10025	WASHER, FLAT 3/8 SAE	AS REQ'D.
26	72213	SPACER, 5/8OD X 3/8ID X 1-1/2L	1
27	50115	IDLER PULLEY 3"OD X 1GR.AB X 3/8"B	1
28	10811	WASHER, LOCK 3/8	1
29	10404	NUT 3/8-16	1
30	10282	BELT B-53	1
31	10016	KEY 3/16SQ X 1-1/2	1
32	72223	SHEAVE 4"OD X 1GR.B X 5/8"BORE	1
33	15138	METER, HOUR, REDINGTON INDUCTIVE (OPTIONAL)	1



A Division of Equipment Development Company, Inc.

ILLUSTRATION 3: MOTOR GROUPING

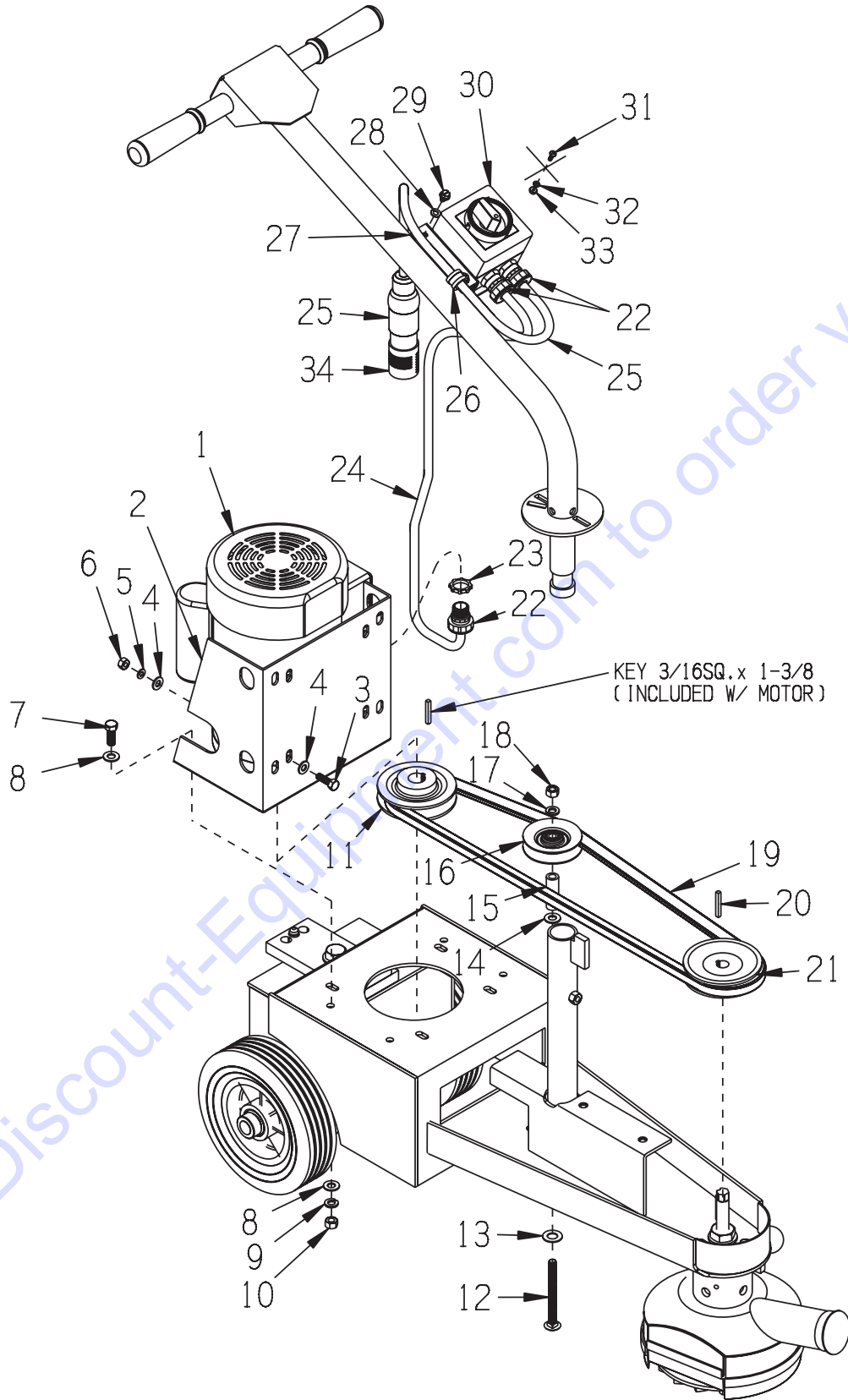

PARTS LISTING - ILLUSTRATION 3: MOTOR GROUPING

ITEM #	PART #	DESCRIPTION	QTY.
1	16037	MOTOR, LEESON CAT. NO. 120867 2HP-1PH-60HZ-1740RPM-115/208-230V <i>MOTOR REPLACEMENT PARTS:</i>	1
	16174	CAPACITOR, RUN, LEESON 003014.02 (50MFD-240V)	1
	16167	CAPACITOR, START, LEESON 003025.18(600MFD-125V)	1
	16161	RESET BUTTON, LEESON 2 HP, BRJ44DB	1
2	86312	MOUNT, MOTOR	1
3	10806	SCREW, CAP 5/16-18 X 1	4
4	10213	WASHER, FLAT 5/16 SAE	8
5	10801	WASHER, LOCK 5/16	4
6	10054	NUT 5/16-18	4
7	10021	SCREW, CAP 3/8-24 X 1	4
8	10025	WASHER, FLAT 3/8 SAE	8
9	10811	WASHER, LOCK 3/8	4
10	10014	NUT 3/8-24	4
11	72012	SHEAVE 4"OD X 1GR.B X 7/8"BORE	1
12	10910	BOLT, CARRIAGE 3/8-16 X 4" F.T.	1
13	10040	WASHER, GARRET 17/32 X 1 X .054	1
14	10025	WASHER, FLAT 3/8 SAE	AS REQ'D.
15	72214	SPACER, 5/8OD X 3/8ID X 1-7/8L	1
16	50115	IDLER PULLEY 3"OD X 1GR.AB X 3/8"B	1
17	10811	WASHER, LOCK 3/8	1
18	10404	NUT 3/8-16	1
19	10282	BELT B-53	1
20	10016	KEY 3/16SQ X 1-1/2	1
21	72223	SHEAVE 4"OD X 1GR.B X 5/8"BORE	1
22	41130	STRAIN RELIEF 1/2NPT X .550-.650"	3
23	10790	CONDUIT LOCK NUT 1/2 NP	1
24	77045	WIRE HARNESS 12/3 X 42"LOA	1
25	77044	PLUG W/ 12/3 WIRE HARNESS, LOCKING	1
26	11690	CLAMP, LOOM, 3/8"	1
27	77042	BRACKET, LOVATO ROTARY CAM SWITCH	1
28	10038	WASHER, LOCK 1/4	2
29	10018	SCREW, CAP 1/4-20 X 3/4	2
30	77043	SWITCH, ROTARY CAM ON/OFF, LOVATO	1
*31	11663	SCREW, MACHINE 8-32 X 1/2	4
*32	10461	WASHER, LOCK, INT. TOOTH #8	4
*33	10462	NUT, KEPS 8-32	4
34	40041	CONNECTOR, LOCKING 20A/125V L5-20R	1
* NOTE: ITEMS 31, 32, & 33 MOUNT THE SWITCH (ITEM# 30) TO BRACKET (ITEM# 27)			

ILLUSTRATION 4: RIGID HEAD ASSEMBLY

PART # 72312

STANDARD ON GASOLINE MODEL
OPTIONAL ON ELECTRIC MODEL

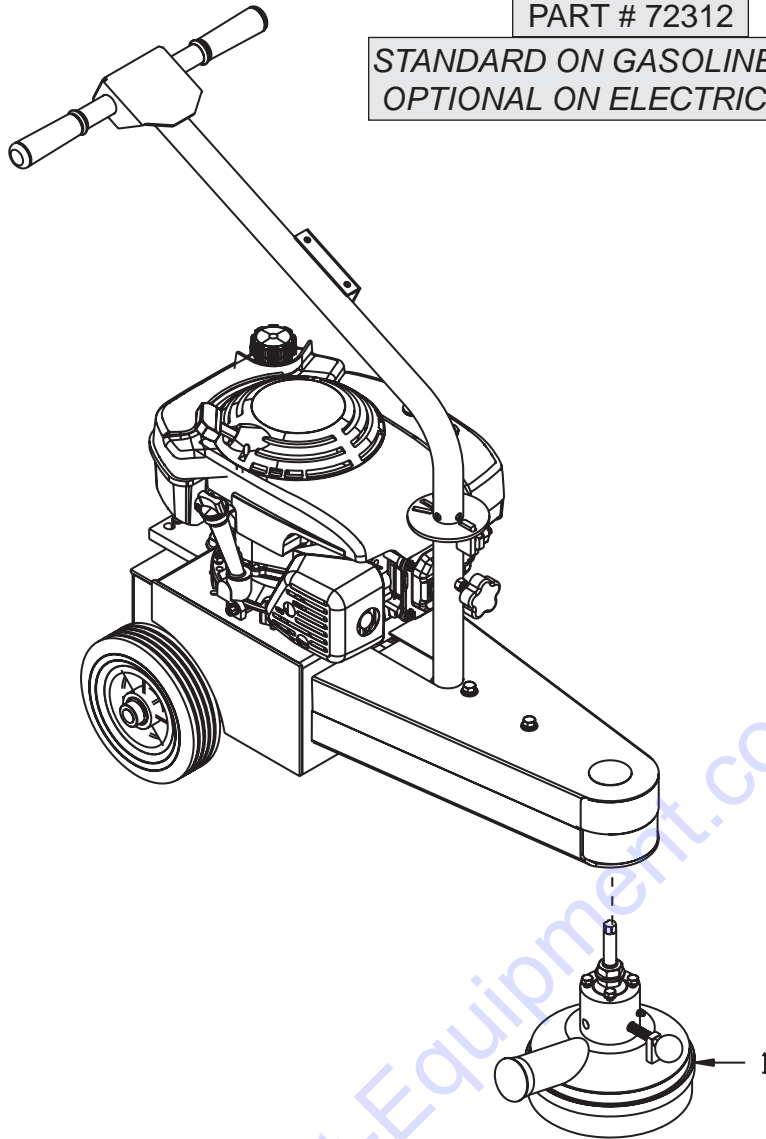

ITEM #	PART #	DESCRIPTION	QTY.	ITEM #	PART #	DESCRIPTION	QTY.
1	72312	HEAD ASSY. W/ COVER, RIGID (INCLUDES ITEMS 2-29)	1	15	11671	SCREW, SKT. HD. CAP 5/16-24 X 2-1/2	1
2	10403	NUT, JAM 3/4-10	2	16	28124	SPRING, COMP. 7/16"OD X 2"FL	1
3	72215	WASHER, NORD-LOCK 3/4" (PAIR)	1	17	10424	NUT 5/16-24	1
4	72209	SPACER, 1"OD X 3/4ID X 11/16L	2	18	10920	KNOB, BALL 1-3/8 W/ 5/16-24THD, BLK	1
5	72211	SEAL, BEARING HUB	2	19	72110	CLAMP, HOSE HTM-850 7-3/4 TO 8-5/8	1
6	3687	BEARING, TAPERED ROLLER 3/4"ID CONE	2	20	72109	RUBBER SKIRT, 2 X 25-3/8	1
7	3686	BEARING CUP, TAPERED ROLLER LM11910	2	21	72310	FLANGE W/ SHAFT, RIGID	1
8	72212	RING, EXT. RETAINING 2"	1	22	10030	SCREW, CAP 3/8-24 X 2	3
9	72210	HUB, BEARING	1	23	10811	WASHER, LOCK 3/8	3
10	10053	SCREW, CAP 5/16-18 X 3/4	4	24	72006	WASHER, 1-1/4OD X 13/32ID X 1/8THK	3
11	10801	WASHER, LOCK 5/16	4	25	72007	MOUNT, CENTER BONDED, CB-1120-1	3
12	10808	FITTING, GREASE 1/4-28 STRAIGHT	1	26	72311	SPACER, RIGID HEAD	1
13	72307	COVER, RIGID HEAD	1	27	72024	FLANGE, CUP WHEEL MOUNTING	1
14	65021	CAP/PLUG 2" RED PLASTIC, FLANGED	1	28	10049	PIN, ROLL 1/4 X 1	1
				29	72021	NUT, FLANGE 5/8-11	1

ILLUSTRATION 5: FLEX HEAD ASSEMBLY

PART # 72313

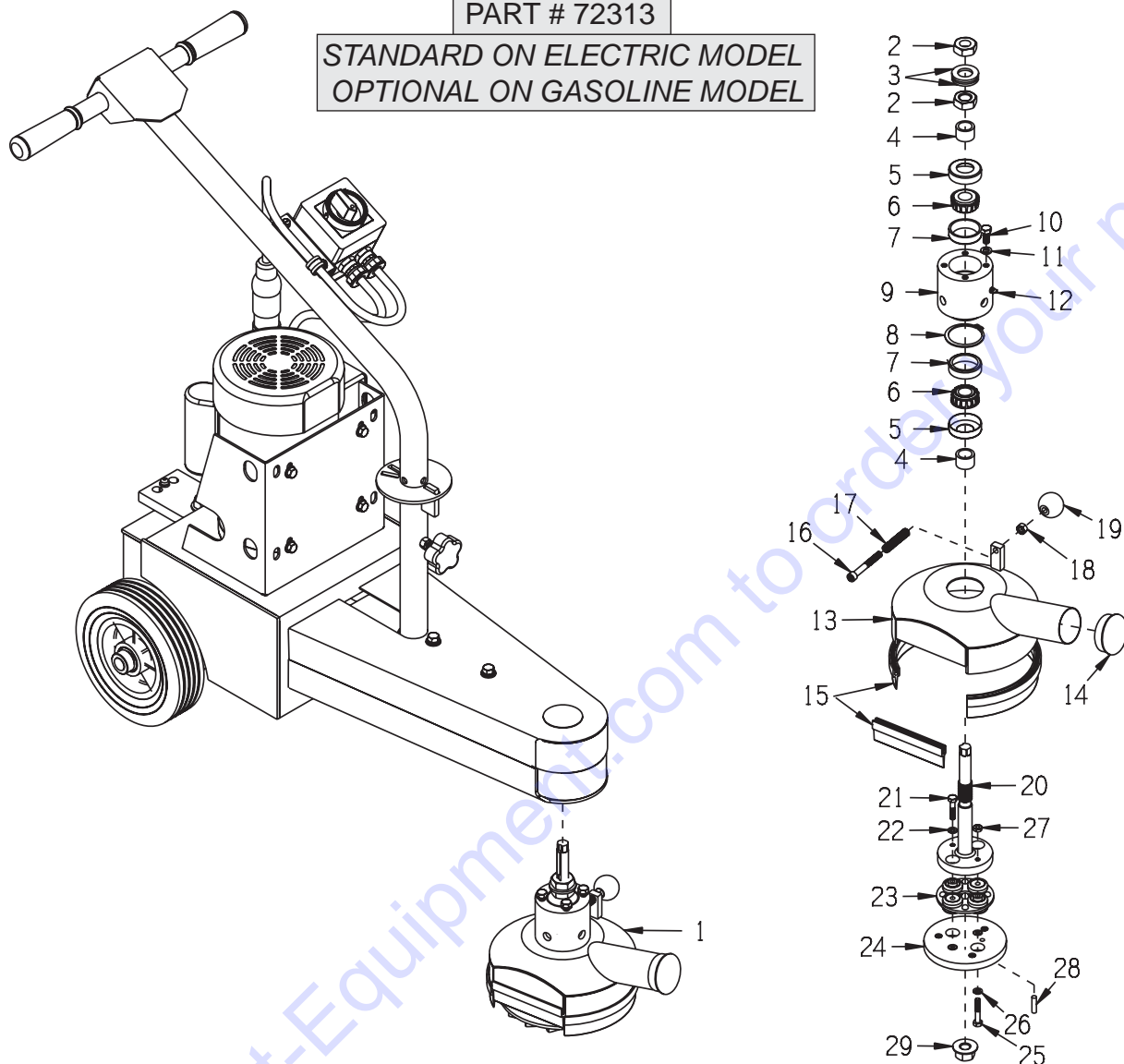
STANDARD ON ELECTRIC MODEL
OPTIONAL ON GASOLINE MODEL

ITEM #	PART #	DESCRIPTION	QTY.	ITEM #	PART #	DESCRIPTION	QTY.
1	72313	HEAD ASSY. W/ COVER, FLEX (INCLUDES ITEMS 2-30)	1	15	72314	SEAL-STRIP 25"L (CUT TO FIT HEAD COVER)	1
2	10403	NUT, JAM 3/4-10	2	16	11671	SCREW, SKT. HD. CAP 5/16-24 X 2-1/2	1
3	72215	WASHER, NORD-LOCK 3/4" (PAIR)	1	17	28124	SPRING, COMP. 7/16"OD X 2"FL	1
4	72209	SPACER, 1"OD X 3/4ID X 11/16L	2	18	10424	NUT 5/16-24	1
5	72211	SEAL, BEARING HUB	2	19	10920	KNOB, BALL 1-3/8 W/ 5/16-24THD, BLK	1
6	3687	BEARING, TAPERED ROLLER 3/4"ID CONE	2	20	72208	FLANGE(HUB) W/ SHAFT, FLEX	1
7	3686	BEARING CUP, TAPERED ROLLER LM11910	2	21	11656	SCREW, CAP 1/4-28 X 1-1/4, GRADE 8	2
8	72212	RING, EXT. RETAINING 2"	1	22	10038	WASHER, LOCK 1/4	2
9	72210	HUB, BEARING	1	23	72025	COUPLING, MORFLEX 302	1
10	10053	SCREW, CAP 5/16-18 X 3/4	4	24	72024	FLANGE, CUP WHEEL MOUNTING	1
11	10801	WASHER, LOCK 5/16	4	25	11657	SCREW, CAP 1/4-28 X 1-1/2, GRADE 8	2
12	10808	FITTING, GREASE 1/4-28 STRAIGHT	1	26	10038	WASHER, LOCK 1/4	2
13	72308	COVER, FLEX HEAD	1	27	11662	NUT, HEX NYLON JAM 1/4-28	2
14	65021	CAP/PLUG 2" RED PLASTIC, FLANGED	1	28	10049	PIN, ROLL 1/4 X 1	1
				29	72021	NUT, FLANGE 5/8-11	1



A Division of Equipment Development Company, Inc.

**ILLUSTRATION 6: OPTIONAL SCARIFIER DISC ASSEMBLY
FOR USE ON MODELS WITH RIGID HEAD ONLY**

PART # 72040

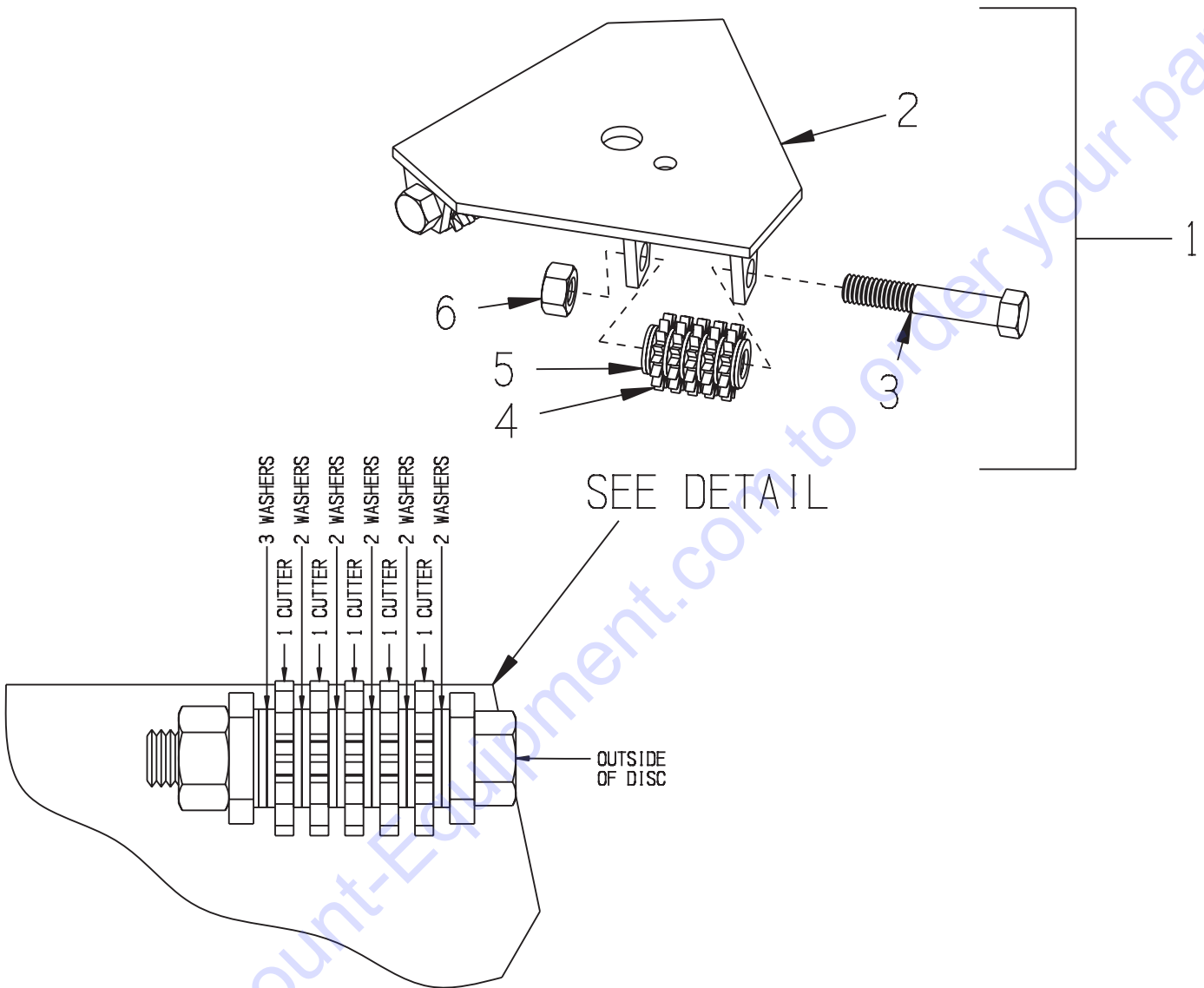

ITEM #	PART #	DESCRIPTION	QTY.
1	72040	7EDSD SCARIFIER DISC ASSY. 7" (INCLUDES ITEMS 2-6)	1
2	72041	DISC, SCARIFIER 7"	1
3	10175	SCREW, CAP 7/16-14 X 2-1/2 GRADE 8	3
4	72050	CUTTER WHEEL 1-3/16"(SOLID CARBIDE)	15
5	72045	WASHER, FLAT 7/16" 18-8SS AN960	39
6	10176	NUT, HEX NYLON LOCK 7/16-14	3

WIRING DIAGRAM FOR ELECTRIC MOTOR - LEESON 120867 2HP-1PH-60HZ-115/208-230V

005053-02

VIEW FROM OUTSIDE OF MOTOR AT SWITCH END.

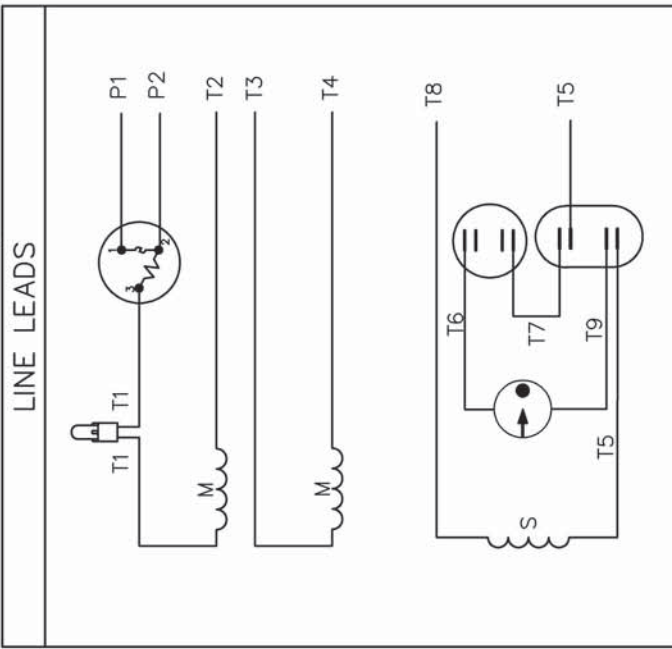

ROTATION FACING LEAD END	L1	L2	JOIN	INSULATE SEPARATELY
HIGH VOLT	P1	T4 T5	T2,T3 T8	P2
LOW VOLT	P1	T2,T4 T5	T2,T3 T8	-----
	P1	T2,T4 T8	P2,T3 T5	-----

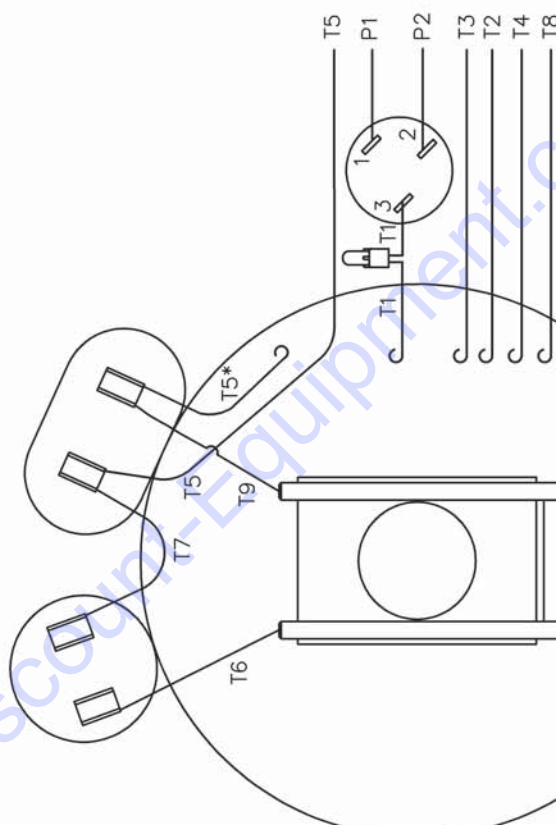

* THIS LEAD MAY BE WHITE

REGAL-BELOIT <i>Motor Technologies</i> GROUP		DRAWN ADH 06/16/76	
TITLE EXTERNAL WIRING DIAGRAM TYPE "K" W/PROTECTOR		CHK WRK 06/30/76	APPD
MATERIAL DECAL 004011		SCALE 1=1	REF
FINISH		FINF 6K17FB8A	PREV
CAD FILE 00505302		SIZE A	DRAWING NO. 005053-02
DIST		REV. 04	

UNLESS SPECIFIED	TOLERANCES	
	DEC.	INCHES
.X	±.1	
.XX	±.01	
.XXX	±.005	
.XXXX	±.0005	
CHK ANG	±1/2°	

NO.	REVISION	BY & DATE	CHK	ANG	RFP	DIST
04	ADDED "*" TO T5	RLW 7/22/02				
03	REDRAWN ON CAD	DBT 05/27/97				

THIS DRAWING IN DESIGN AND DETAIL IS OUR PROPERTY AND MUST NOT BE USED EXCEPT IN CONNECTION WITH OUR WORK. ALL RIGHTS OF DESIGN AND INVENTION ARE RESERVED. THIS IS AN ELECTRONICALLY GENERATED DOCUMENT - DO NOT SCALE THIS PRINT

WIRING DIAGRAM FOR LOVATO ROTARY CAM SWITCH

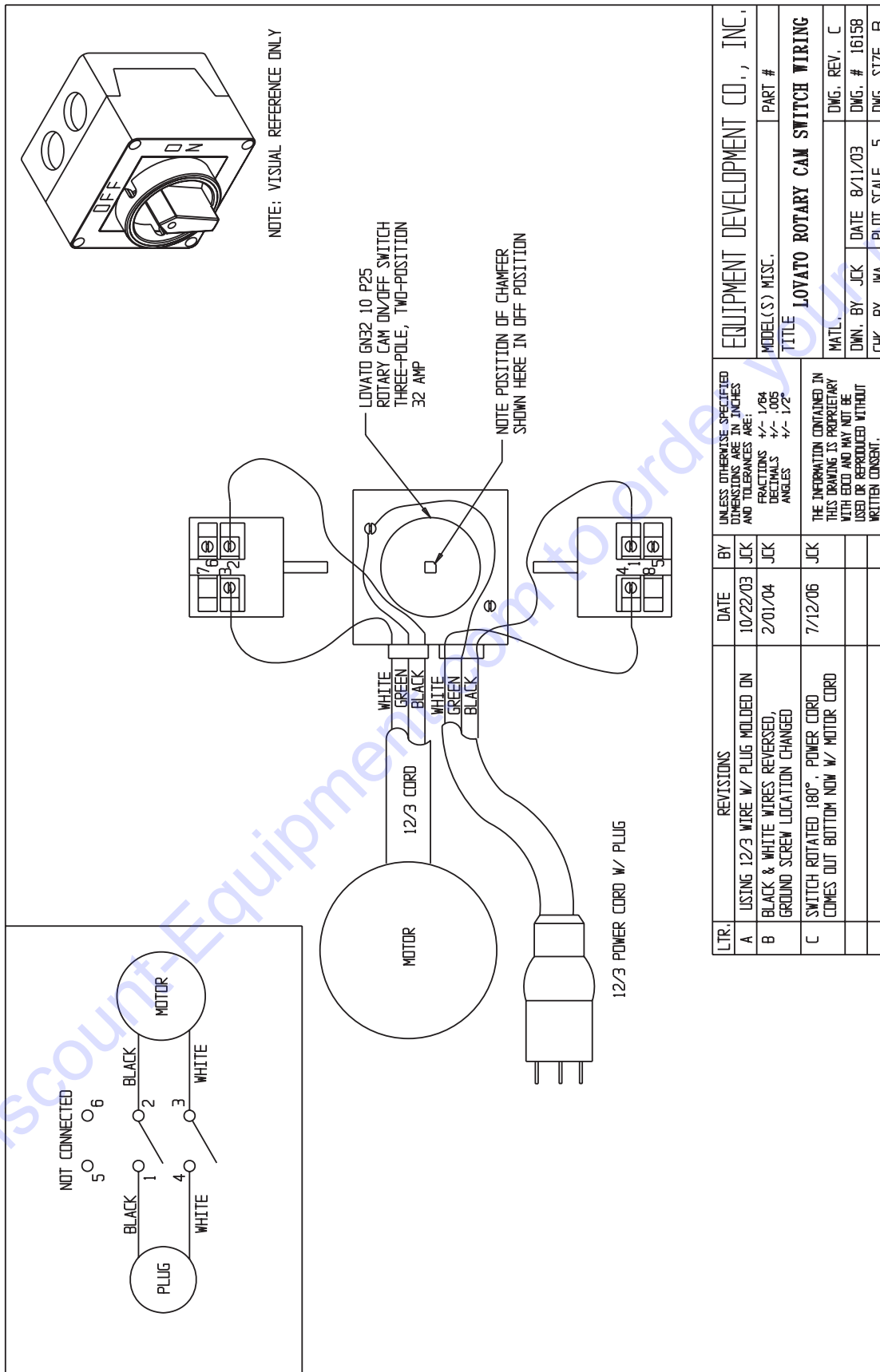

PARTS FINDER

**Search Website
by Part Number**



**Search Manual
Library For Parts
Manual & Lookup Part
Numbers – Purchase
or Request Quote**

Search Manuals

Enter your information to help us find the right parts manual for your machine.

* Brand:

* Model:

* Serial:

* Part Number:

SEARCH

**Can't Find Part or
Manual? Request Help
by Manufacturer,
Model & Description**

Parts Order Form

Please fill in the following information to help us find the right part for your machine.

Manufacturer:	<input type="text"/>
Model:	<input type="text"/>
Description:	<input type="text"/>
Part Number:	<input type="text"/>
Quantity:	<input type="text"/>
Notes:	<input type="text"/>

Discount-Equipment.com is your online resource for quality parts & equipment.

Florida: **561-964-4949** Outside Florida TOLL FREE: **877-690-3101**

Need parts?

Click on this link: <http://www.discount-equipment.com/category/5443-parts/> and choose one of the options to help get the right parts and equipment you are looking for. Please have the machine model and serial number available in order to help us get you the correct parts. If you don't find the part on the website or on one of the online manuals, please fill out the request form and one of our experienced staff members will get back to you with a quote for the right part that your machine needs.

We sell worldwide for the brands: Genie, Terex, JLG, MultiQuip, Mikasa, Essick, Whiteman, Mayco, Toro Stone, Diamond Products, Generac Magnum, Airman, Haulotte, Barreto, Power Blanket, Nifty Lift, Atlas Copco, Chicago Pneumatic, Allmand, Miller Curber, Skyjack, Lull, Skytrak, Tsurumi, Husquvarna Target, Stow, Wacker, Sakai, Mi-T-M, Sullair, Basic, Dynapac, MBW, Weber, Bartell, Bennar Newman, Haulotte, Ditch Runner, Menegotti, Morrison, Contec, Buddy, Crown, Edco, Wyco, Bomag, Laymor, EZ Trench, Bil-Jax, F.S. Curtis, Gehl Pavers, Heli, Honda, ICS/PowerGrit, IHI, Partner, Imer, Clipper, MMD, Koshin, Rice, CH&E, General Equipment, Amida, Coleman, NAC, Gradall, Square Shooter, Kent, Stanley, Tamco, Toku, Hatz, Kohler, Robin, Wisconsin, Northrock, Oztec, Toker TK, Rol-Air, APT, Wylie, Ingersoll Rand / Doosan, Innovatech, Con X, Ammann, Mecalac, Makinex, Smith Surface Prep, Small Line, Wanco, Yanmar