

REVISED STARTING  
SERIAL # 150410237

# PARTS LIST MANUAL

## HEAVY-DUTY FLOOR GRINDER / POLISHER

### PROPANE MODELS



MODEL 2DHDP-18P  
SKU # 58200



MODEL 2DP-18P  
SKU # 53900P



# PARTS FINDER

**Search Website  
by Part Number**



**Search Manual  
Library For Parts  
Manual & Lookup Part  
Numbers – Purchase  
or Request Quote**

**Search Manuals**

Enter your information to help us find the right parts manual for your machine.

\* Brand:

\* Model:

\* Serial:

\* Part Number:

SEARCH

**Can't Find Part or  
Manual? Request Help  
by Manufacturer,  
Model & Description**

**Parts Order Form**

Please fill in the following information to help us find the right part for your machine.

Manufacturer:	<input type="text"/>
Model:	<input type="text"/>
Description:	<input type="text"/>
Part Number:	<input type="text"/>
Quantity:	<input type="text"/>
Notes:	<input type="text"/>

Discount-Equipment.com is your online resource for quality parts & equipment.

Florida: **561-964-4949** Outside Florida TOLL FREE: **877-690-3101**

**Need parts?**

Click on this link: <http://www.discount-equipment.com/category/5443-parts/> and choose one of the options to help get the right parts and equipment you are looking for. Please have the machine model and serial number available in order to help us get you the correct parts. If you don't find the part on the website or on one of the online manuals, please fill out the request form and one of our experienced staff members will get back to you with a quote for the right part that your machine needs.

We sell worldwide for the brands: Genie, Terex, JLG, MultiQuip, Mikasa, Essick, Whiteman, Mayco, Toro Stone, Diamond Products, Generac Magnum, Airman, Haulotte, Barreto, Power Blanket, Nifty Lift, Atlas Copco, Chicago Pneumatic, Allmand, Miller Curber, Skyjack, Lull, Skytrak, Tsurumi, Husquvarna Target, Stow, Wacker, Sakai, Mi-T-M, Sullair, Basic, Dynapac, MBW, Weber, Bartell, Bennar Newman, Haulotte, Ditch Runner, Menegotti, Morrison, Contec, Buddy, Crown, Edco, Wyco, Bomag, Laymor, EZ Trench, Bil-Jax, F.S. Curtis, Gehl Pavers, Heli, Honda, ICS/PowerGrit, IHI, Partner, Imer, Clipper, MMD, Koshin, Rice, CH&E, General Equipment, Amida, Coleman, NAC, Gradall, Square Shooter, Kent, Stanley, Tamco, Toku, Hatz, Kohler, Robin, Wisconsin, Northrock, Oztec, Toker TK, Rol-Air, APT, Wylie, Ingersoll Rand / Doosan, Innovatech, Con X, Ammann, Mecalac, Makinex, Smith Surface Prep, Small Line, Wanco, Yanmar

## READ AND UNDERSTAND THE OPERATORS INSTRUCTION MANUAL *THOROUGHLY* BEFORE ATTEMPTING TO OPERATE THIS EQUIPMENT.



**Death or serious injury could occur if this machine is used improperly.**



### SAFETY MESSAGES

- Safety Instructions are preceded by a graphic alert symbol of DANGER, WARNING, or CAUTION.



Indicates an imminent hazard which, if not avoided, will result in death or serious injury.



Indicates an imminent hazard which, if not avoided, can result in death or serious injury.



Indicates hazards which, if not avoided, could result in serious injury and or damage to the equipment.

### GASOLINE/PROPANE POWERED EQUIPMENT



- Engine exhaust from this product contains chemicals known to the State of California to cause cancer, birth defects or other reproductive harm.



- Gasoline is extremely flammable and poisonous. It should only be dispensed in well ventilated areas, and with a cool engine.

- Small gasoline engines produce high concentrations of carbon monoxide (CO) example: a 5 HP 4 cycle engine operation in an enclosed 100,000 cu. ft. area with only one change of air per hour is capable of providing deadly concentrations of CO in less than fifteen minutes. Five changes of air in the same area will produce noxious fumes in less than 30 minutes. Gasoline or propane powered equipment should not be used in enclosed or partially enclosed areas. Symptoms of CO poisoning include, headache, nausea, weakness, dizziness, visual problems and loss of consciousness. If symptoms occur - get into fresh air and seek medical attention immediately.

### ELECTRICAL POWERED EQUIPMENT



Extreme care must be taken when operating electric models with water present: Ensure power cord is properly grounded, is attached to a Ground-Fault-Interrupter (GFI) outlet, and is undamaged.

- Check all electrical cables - be sure connections are tight and cable is continuous and in good condition. Be sure cable is correctly rated for both the operating current and voltage of this equipment.
- Improper connection of the equipment-grounding conductor can result in a risk of electric shock. Check with qualified electrician or service person if there is any doubt as to whether the outlet is properly grounded. Adhere to all local codes and ordinances.
- **NOTE:** In the event of a malfunction or breakdown, grounding provides a path of least resistance for the electric current to dissipate. The motor is equipped with a grounded plug and must be connected to an outlet that is properly installed and properly grounded. DO NOT modify the plug provided on the motor. If the plug does not fit the outlet have a qualified electrician install the proper receptacle.
- Switch motor OFF **before** disconnecting power.

- Do not disconnect power by pulling cord. To disconnect, grasp the plug, not the cord.
- Unplug power cord at the machine when not in use and before servicing.

### GENERAL INSTRUCTIONS

- Equipment should only be operated by trained personnel in good physical condition and mental health (not fatigued). The operator and maintenance personnel must be physically able to handle the bulk weight and power of this equipment.
- This is a one person tool. Maintain a safe operating distance to other personnel. It is the **operators' responsibility** to keep other people (workers, pedestrians, bystanders, etc.) away during operation. Block off the work area in all directions with roping, safety netting, etc. for a safe distance. Failure to do so may result in others being injured by flying debris or exposing them to harmful dust and noise.
- This equipment is intended for commercial use only.
- For the operator's safety and the safety of others, always keep all guards in place during operation.
- Never let equipment run unattended.



- Personal Protection Equipment and proper safety attire must be worn when operating this machinery. The operator must wear approved safety equipment appropriate for the job such as hard hat and safety shoes when conditions require. Hearing protection **MUST** be used (operational noise levels of this equipment may exceed 85db). Eye protection **MUST** be worn at all times.



Keep body parts and loose clothing away from moving parts. Failure to do so could result in dismemberment or death.

- Do not modify the machine.
  - Stop motor/engine when adjusting or servicing this equipment.
- Maintain a safe operating distance from flammable materials. Sparks from the cutting-action of this machine can ignite flammable materials or vapors.

### DUST WARNING



Some dust created by power sanding, sawing, grinding, drilling, and other construction activities contains chemicals known to cause cancer, birth defects, or other reproductive harm. Some examples of these chemicals are:

- Lead from lead-based paints, and
  - Crystalline silica from bricks and concrete and other masonry products.
- Your risk of exposure to these chemicals varies depending on how often you do this type of work. To reduce your risk: work in a well ventilated area, use a dust control system, such as an industrial-style vacuum, and wear approved personal safety equipment, such as a dust/particle respirator designed to filter out microscopic particles.

# PARTS LIST MANUAL

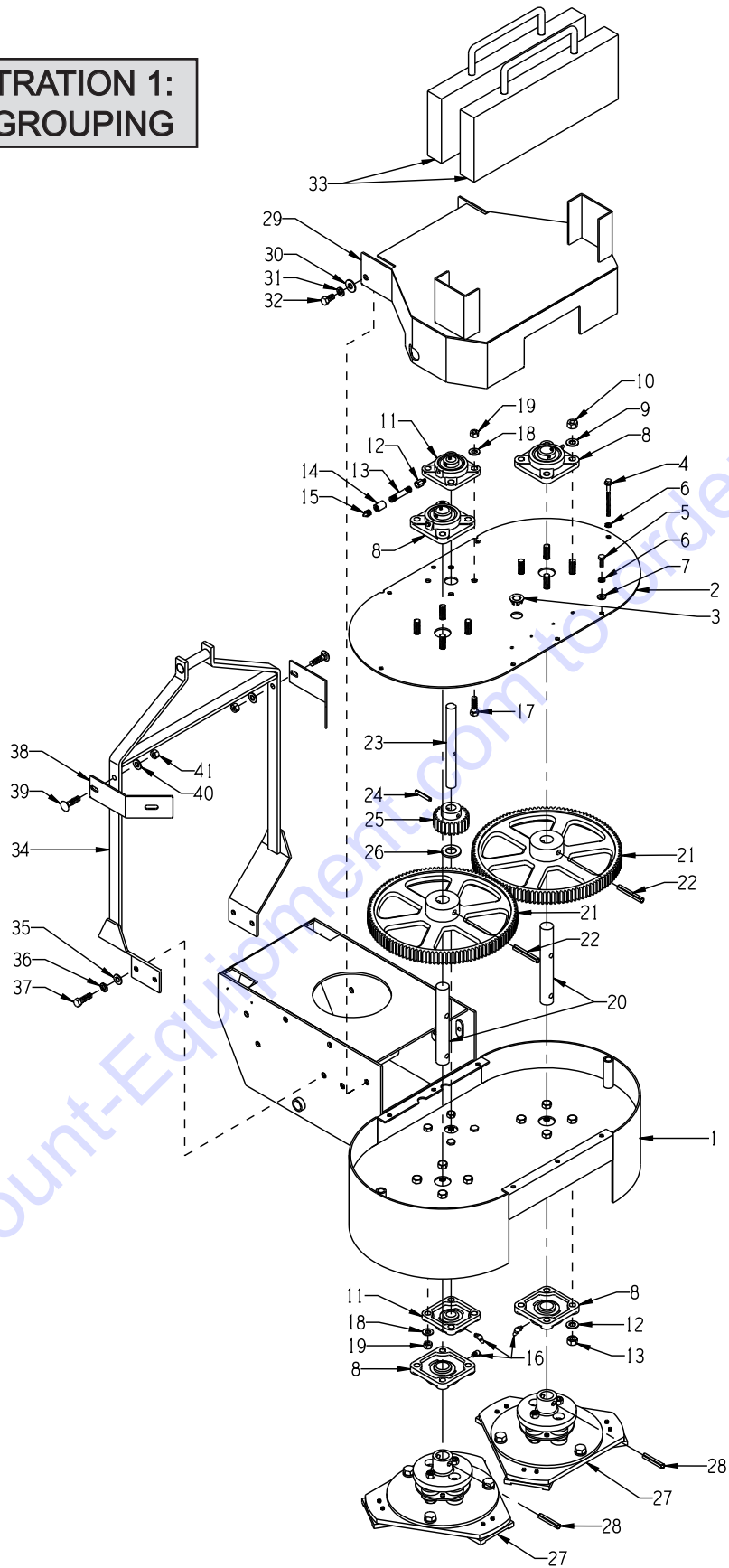
## HEAVY-DUTY FLOOR GRINDER/POLISHER

### PROPANE MODELS

#### TABLE OF CONTENTS

<u>Section</u>	<u>Page Number</u>
Safety Messages and General Instructions .....	2
How To Order Replacement Parts .....	3
Illustration 1: Main Grouping .....	4, 5
Illustration 2: Handle & Wheel Carriage Grouping .....	6, 7
Illustration 3: Skirt, Vacuum Port & Water Hook-Up Grouping .....	8, 9
Illustration 4: Disc Assembly .....	10
Illustration 5: Disc Arrangement .....	11
Illustration 6: Propane Engine & Belt Drive Grouping .....	12, 13
Illustration 7: Propane Tank Grouping .....	14, 15
Illustration 8: Electrical Component Grouping .....	16, 17
Wiring Diagram .....	18
Blank Page .....	19
Decal Sheet 1 .....	20
Decal Sheet 2 .....	21
Blank Page .....	22
Notes .....	23
Limited Equipment Warranty of Sale - Terms & Conditions .....	24 (Back Page)

**ILLUSTRATION 1:  
MAIN GROUPING**

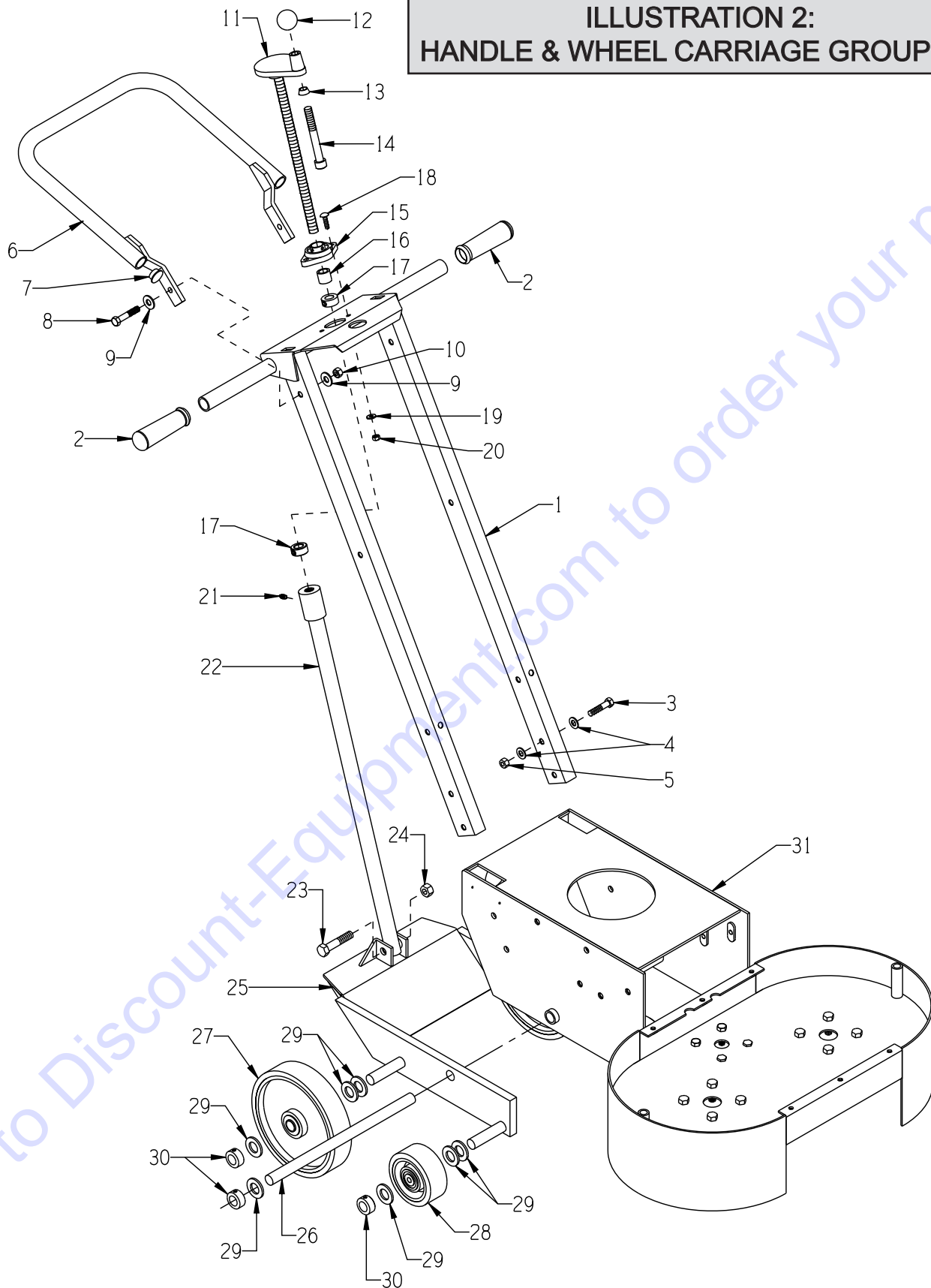


Go to Discount-Equipment.com to order your parts



PARTS LISTING - ILLUSTRATION 1 : MAIN GROUPING			
ITEM #	PART #	DESCRIPTION	QTY.
1	77501	MAIN FRAME	1
2	77502P	COVER, GEAR CASE (PROPANE)	1
3	10005	PLUG, HOLE 7/8" BRIGHT ZINC	1
4	11697	SCREW, FLANGE HEX 1/4-20 X 3	2
5	10018	SCREW, CAP 1/4-20 X 3/4	6
6	10038	WASHER, LOCK 1/4 ZINC	8
7	10602	WASHER, FLAT 1/4 SAE ZINC	6
8	77008	BEARING, BALL 1" 4-HOLE FLANGE, ND	4
9	10450	WASHER, LOCK 7/16 ZINC	16
10	10481	NUT, HEX 7/16-20 ZINC	16
11	77009	BEARING, BALL 3/4" 4-HOLE FLANGE	2
12	50541	ADAPTER, GREASE FIT. 1/8PT X 1/4-28	1
13	10699	PIPE NIPPLE 1/8NPT X 2" (BLACK)	1
14	10585	PIPE COUPLING 1/8 NPT (BLACK STEEL)	1
15	10953	FITTING, GREASE 1/8 NPT STRAIGHT	1
16	10960	FITTING, GREASE 1/4-28 X 45°	3
17	10309	SCREW, CAP 3/8-24 X 1-1/4 ZINC	4
18	10811	WASHER, LOCK 3/8 ZINC	4
19	10014	NUT, HEX 3/8-24 ZINC	4
20	77346	SHAFT, LARGE GEAR 1"DIA X 7"L	2
21	77012	GEAR, SPUR 112 TOOTH (DRIVEN)	2
22	63056	PIN, H.D.COILED SPRING 3/8 X 2-1/2	2
23	77011	SHAFT, PINION GEAR 3/4DIA X 7-3/8"L	1
24	10037	PIN, ROLL 1/4 X 1-1/2	1
25	77053	GEAR, SPUR 25 TOOTH (PINION)	1
26	10009	WASHER, FLAT 3/4 SAE ZINC	1
27	77535	DISC ASSY. COMPLETE (REFER TO ILLUSTRATION 4 FOR BREAKDOWN)	2
28	10063	PIN, ROLL 3/8 X 2	2
29	77531	HOOD, PROPANE MODEL	1
30	10025	WASHER, FLAT 3/8 SAE ZINC	2
31	10811	WASHER, LOCK 3/8 ZINC	2
32	10907	SCREW, CAP 3/8-16 X 3/4	2
33	77506	WEIGHT BLOCK, 40 LB.	2
34	77532	LIFTING BAIL	1
35	10025	WASHER, FLAT 3/8 SAE ZINC	4
36	10811	WASHER, LOCK 3/8 ZINC	4
37	10309	SCREW, CAP 3/8-24 X 1-1/4 ZINC	4
38	77554	BRACKET, MUFFLER, 2DP/2DHDP-18P	2
39	10320	BOLT, CARRIAGE 3/8-16 X 1-1/4 F.T.	2
40	10025	WASHER, FLAT 3/8 SAE ZINC	2
41	10156	NUT, HEX NYLON LOCK 3/8-16 ZINC	2

**ILLUSTRATION 2:  
HANDLE & WHEEL CARRIAGE GROUPING**

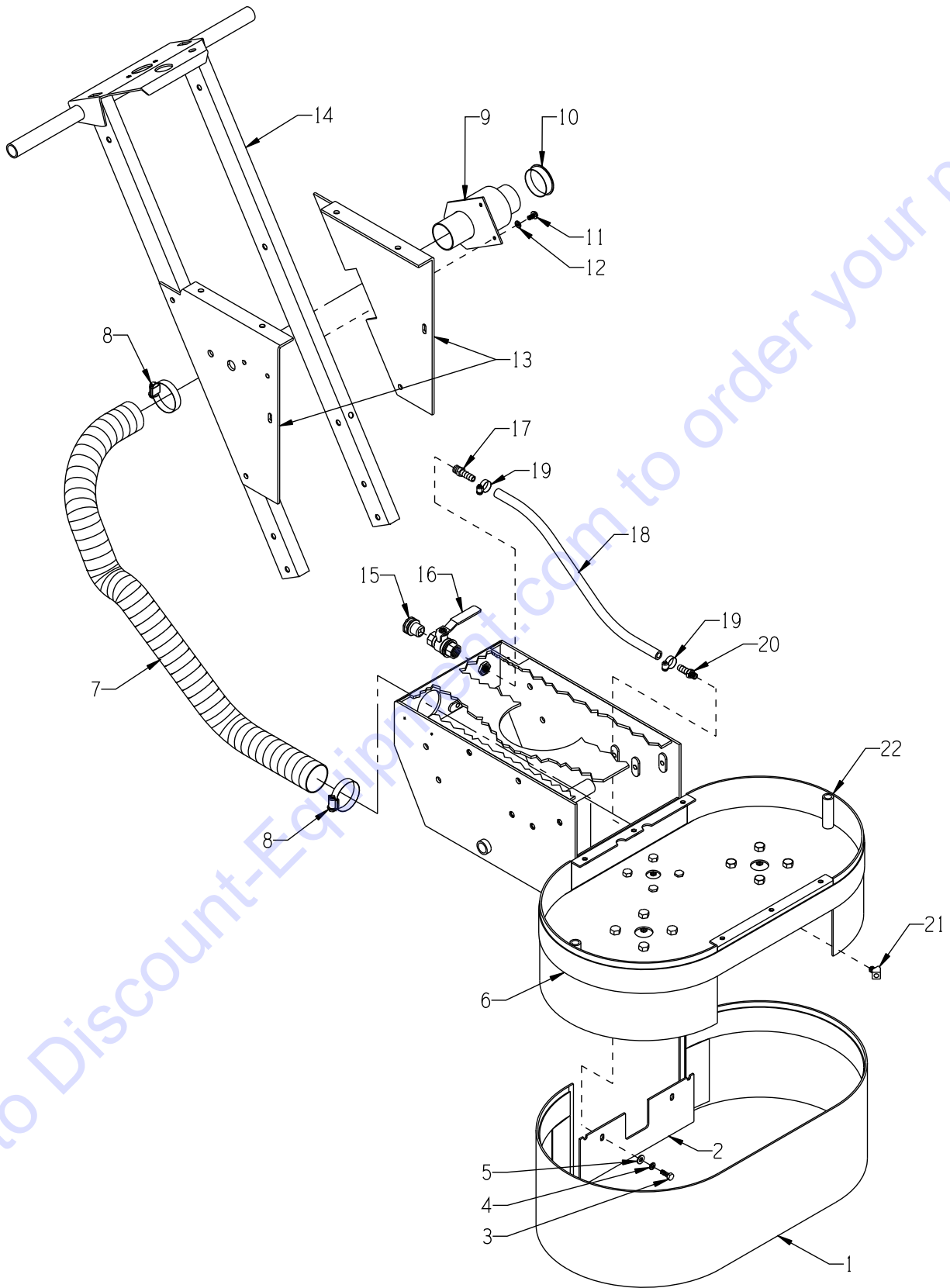


Go to Discount-Equipment.com to order your parts

<b>PARTS LISTING - ILLUSTRATION 2 : HANDLE &amp; WHEEL CARRIAGE GROUPING</b>			
ITEM #	PART #	DESCRIPTION	QTY.
1	77533	HANDLE BAR, PROPANE MODEL	1
2	10608	GRIP, HAND 1" MODEL AT	2
3	10029	SCREW, CAP 3/8-24 X 1-3/4	4
4	10025	WASHER, FLAT 3/8 SAE ZINC	8
5	10004	NUT, HEX LOCK 3/8-24 ZINC	4
6	77508	HANDLE EXTENSION	1
7	77528	PLUG, BLACK 1"RD. TUBING 10-14 GA.	2
8	10030	SCREW, CAP 3/8-24 X 2	2
9	10025	WASHER, FLAT 3/8 SAE ZINC	4
10	10004	NUT, HEX LOCK 3/8-24 ZINC	2
11	65019	HANDWHEEL, SMALL W/ 5/8-8 X 13"ROD	1
12	14023	KNOB, BALL 1-3/8 W/ 1/2-13THD, BLK.	1
13	50550	SLEEVE, BRASS 1/2" TAPERED	1
14	10346	SCREW, SKT. HD. CAP 1/2-13 X 4-1/2	1
15	80009	BEARING, BALL 5/8" 2-HOLE (NO G.F.)	1
16	55010	SPACER, HANDWHEEL 5/8"ID X 3/4"L	1
17	10096	COLLAR, LOCKING 5/8"ID	2
18	10412	BOLT, CARRIAGE 1/4-20 X 1	2
19	10602	WASHER, FLAT 1/4 SAE ZINC	2
20	10861	NUT, KEPS LOCK 1/4-20 ZINC	2
21	10808	FITTING, GREASE 1/4-28 STRAIGHT	1
22	77534	LINKAGE, LOWER	1
23	10343	SCREW, CAP 1/2-20 X 2-1/2	1
24	10154	NUT, HEX NYLON LOCK 1/2-20 ZINC	1
25	77510	CARRIAGE, WHEEL	1
26	77537	FORK SHAFT 3/4"DIA. X 13-3/4"L	1
27	68008	WHEEL 8 X 1-5/8 X 3/4"BRG., POLY	2
28	77520	WHEEL 4 X 1-1/2 X 3/4"BRG., POLY	2
29	10009	WASHER, FLAT 3/4 SAE ZINC	14
30	10428	COLLAR, LOCKING 3/4"ID	6
31	77501	MAIN FRAME (REFER TO ILLUS. 1)	1

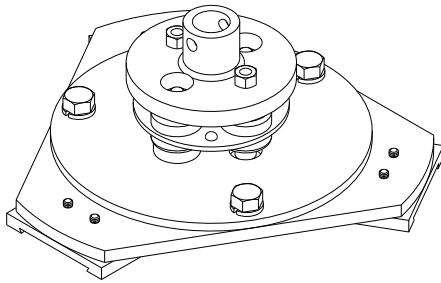


**ILLUSTRATION 3: SKIRT, VACUUM PORT & WATER HOOK-UP GROUPING**



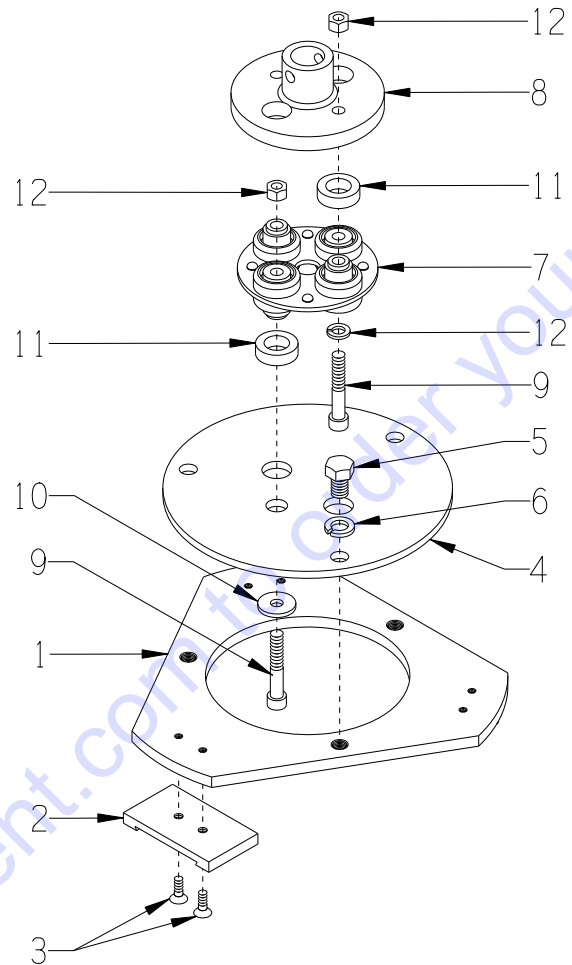
<b>PARTS LISTING - ILLUSTRATION 3 :</b>			
<b>SKIRT, VACUUM PORT &amp; WATER HOOK-UP GROUPING</b>			
<b>ITEM #</b>	<b>PART #</b>	<b>DESCRIPTION</b>	<b>QTY.</b>
1	77529	RUBBER SKIRT 1/8 X 8 X 58 W/VELCRO	1
2	77504	RUBBER SKIRT, REAR 1/8 X 4 X 11	1
3	10018	SCREW, CAP 1/4-20 X 3/4	2
4	10038	WASHER, LOCK 1/4 ZINC	2
5	10602	WASHER, FLAT 1/4 SAE ZINC	2
6	86357	VELCRO-HOOK, 2" WIDE, WATER RESISTANT 1 PIECE CUT 57-1/4"L & 2 PIECES CUT 5-1/4"L	6 FT. TOTAL
7	77551	HOSE, FLEX 2"ID X 36"L	1
8	10766	CLAMP, HOSE, SAE #32, ADJ. TO 2-1/2	2
9	77538	VACUUM PORT	1
10	65021	CAP/PLUG 2" RED PLASTIC, FLANGED	1
11	10846	SCREW, CAP STSHW 1/4-20 X 1/2	2
12	10038	WASHER, LOCK 1/4 ZINC	2
13	-----	SIDE PANELS, HANDLE (REFER TO ILLUS. 7)	2
14	77533	HANDLE BAR, PROP. MODEL (REFER TO ILLUS. 2)	1
15	80021	CONN., SWIVEL FEM. 3/4HOSE X 1/2MPT	1
16	10711	VALVE, BALL 1/2 FPT	1
17	50075	BARB, 3/8 HOSE X 1/4MPT (BRASS)	1
18	77521	HOSE 3/8"ID X 18"L	1
19	50069	CLAMP, HOSE, SAE #6, ADJ. TO 13/16	2
20	10694	BARB, 3/8HOSE X 1/8MPT	1
21	10772	ELBOW, STREET 1/8NPT X 45 (BRASS)	1
22	77501	MAIN FRAME (REFER TO ILLUS. 1)	1

**ILLUSTRATION 4: DISC ASSEMBLY**



**DISC ASSEMBLY COMPLETE**  
**PART # 77535**  
**(ITEMS 1 THRU 12)**

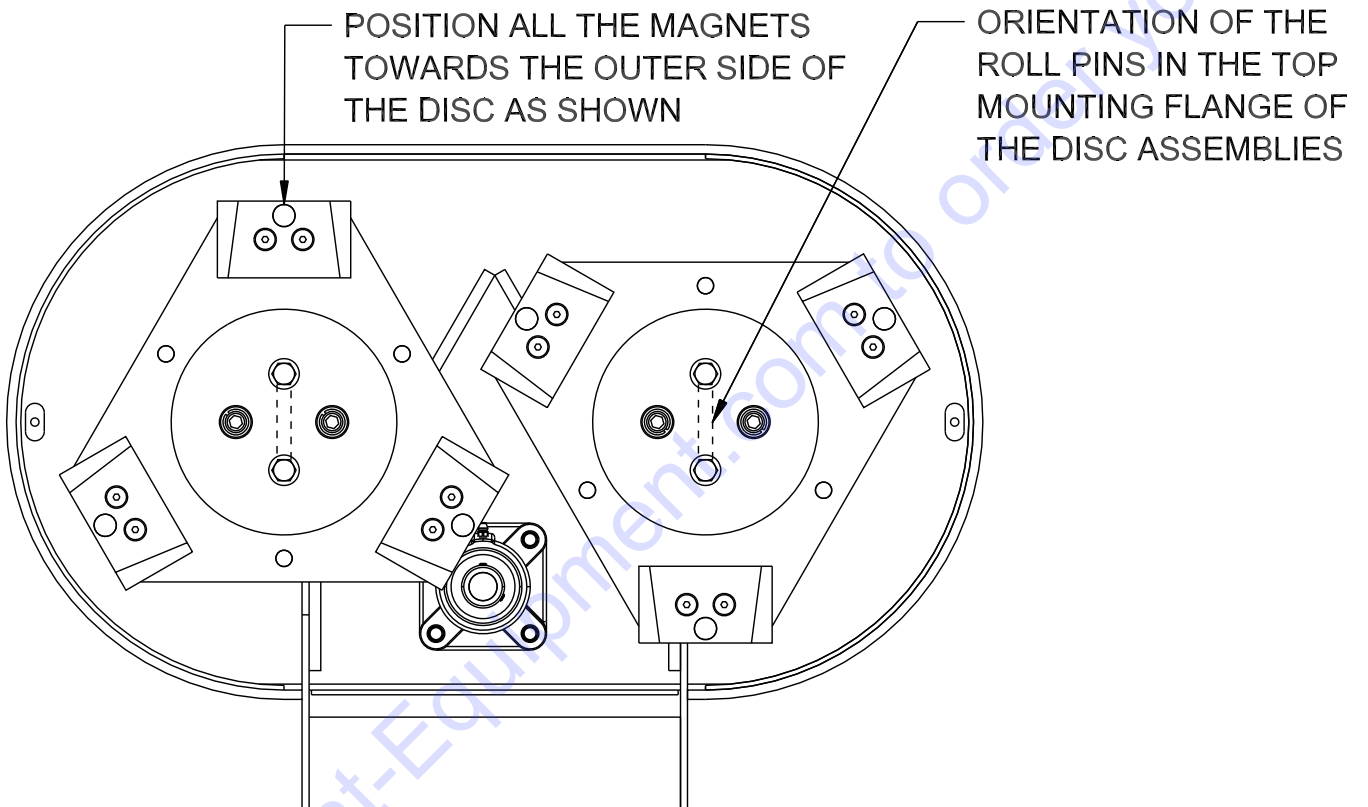
**DISC LOWER HALF SUB-ASSEMBLY**  
**PART # 77536**  
**(ITEMS 1 THRU 6)**



ITEM #	PART #	DESCRIPTION	QTY.*
1	75175	DISC, QUICK-CHANGE	1
2	QC-HOLDER-EDCO	HOLDER, MAGNETIC QUICK CHANGE	3
3	10147	SCREW, FLAT HD SKT 1/4-20 X 3/4	6
4	L18567	DISC TOP PLATE	1
5	11614	SCREW, CAP 1/2-20 X 3/4	3
6	10045	WASHER, LOCK 1/2 ZINC	3
7	86017	COUPLING, MORFLEX 402 CENTER	1
8	77518	FLANGE, MORFLEX COUPLING	1
9	10114	SCREW, SKT. HD. CAP 3/8-24 X 2-1/4	4
10	11695	WASHER, 1.1210 X .3750 X .1280	2
11	86343	BUSHING, RUBBER 1-1/4 X 3/4 X 3/8	4
12	10004	NUT, HEX LOCK 3/8-24 ZINC	4

\*NOTE: QUANTITIES ARE BASED ON 1 DISC. 2 DISC ARE REQUIRED.

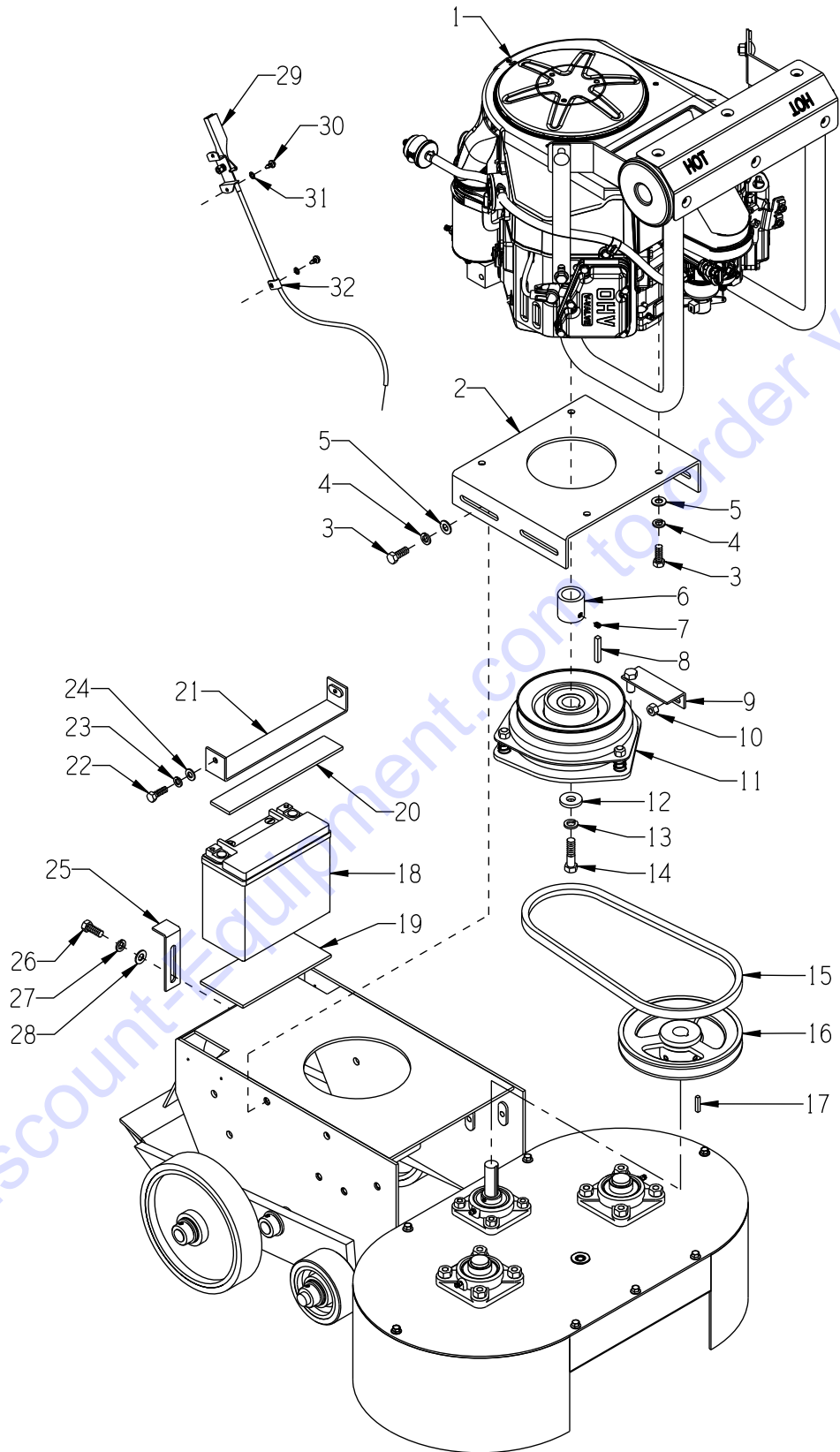
**ILLUSTRATION 5: DISC ARRANGEMENT**



**BOTTOM VIEW**

Go to Discount-Equipment.com for your parts

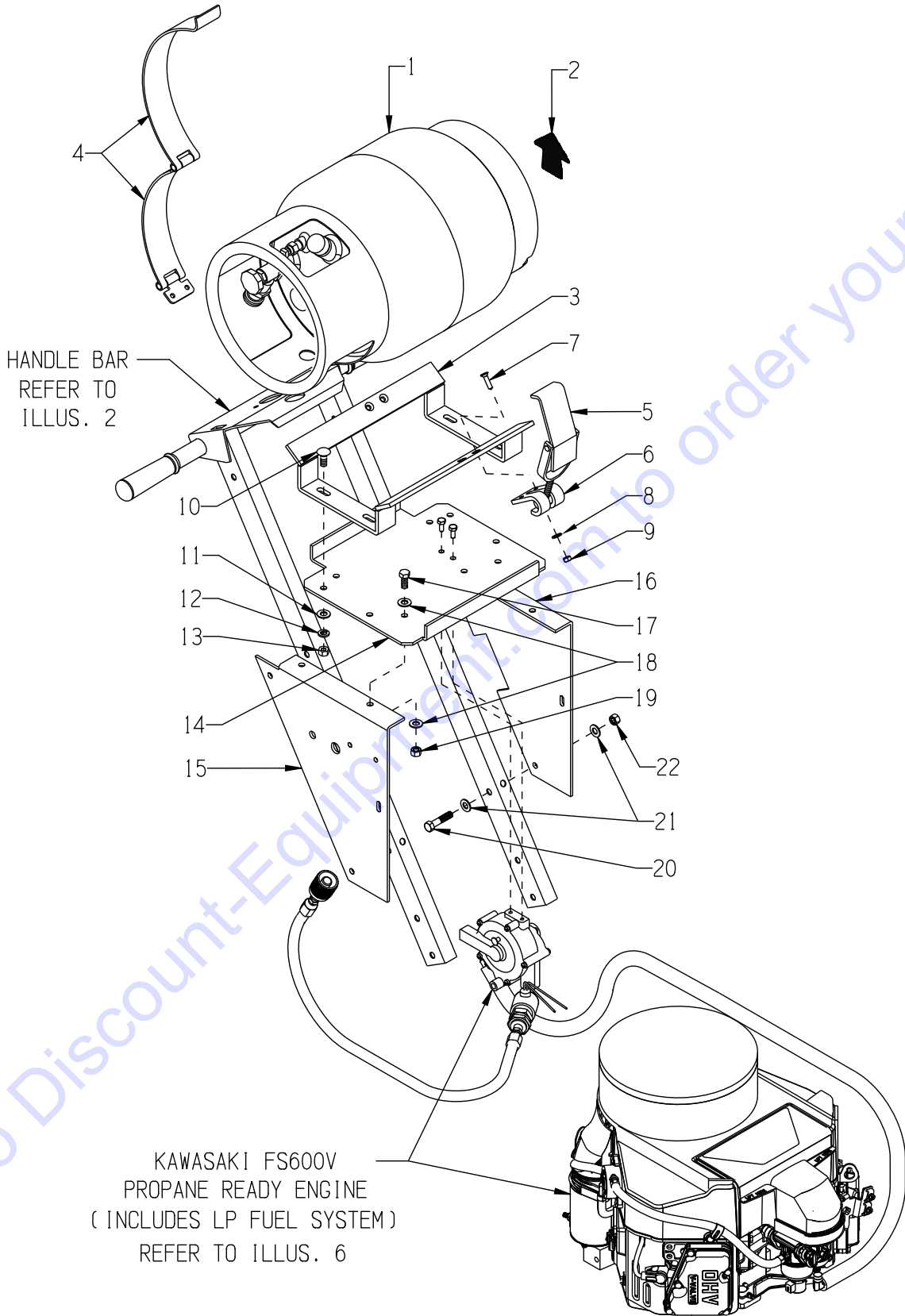
**ILLUSTRATION 6: PROPANE ENGINE & BELT DRIVE GROUPING**



<b>PARTS LISTING - ILLUSTRATION 6 : PROPANE ENGINE &amp; BELT DRIVE GROUPING</b>			
ITEM #	PART #	DESCRIPTION	QTY.
1	15081	ENGINE, KAWASAKI FS600V PROP. READY INCLUDES: 12V STARTER, OIL PRESSURE SWITCH, OIL DRAIN, CATALYTIC MUFFLER. LP FUEL SYSTEM: REGULATOR, INLINE SHUT-OFF VALVE, HIGH & LOW PRESSURE HOSES, & REGO TANK CONNECTOR.	1
2	77539	MOUNT, ENGINE, PROPANE	1
3	10055	SCREW, CAP 3/8-16 X 1	8
4	10811	WASHER, LOCK 3/8 ZINC	8
5	10025	WASHER, FLAT 3/8 SAE ZINC	8
6	77540	SPACER, CLUTCH, PROPANE MODEL	1
7	10139	SCREW, SET 1/4-20 X 5/16	1
8	40317	KEY 1/4SQ X 1-5/8	1
9	77541	BRACKET, CLUTCH RETAINER	1
10	10004	NUT, HEX LOCK 3/8-24 ZINC	2
11	75182	CLUTCH, ELECTRIC, 1 GR00VE	1
12	77542	WASHER, CLUTCH RETAINING 1-1/4"OD X 1/2"ID X 3/16"THK	1
13	10450	WASHER, LOCK 7/16 ZINC	1
14	11699	SCREW, CAP 7/16-20 X 1-3/4	1
15	10277	BELT B-38	1
16	10549	SHEAVE 7"OD X 1GR.B X 3/4"BORE	1
17	10016	KEY 3/16SQ X 1-1/2	1
18	75173	BATTERY 12V, DEKA ETX20L	1
19	77543	RUBBER PAD, BATTERY 3/16 X 3-3/8 X 7	1
20	77544	RUBBER PAD, BATTERY 3/16 X 1-1/2 X 9	1
21	77545	CLAMP, BATTERY HOLD-DOWN	1
22	10018	SCREW, CAP 1/4-20 X 3/4	2
23	10038	WASHER, LOCK 1/4 ZINC	2
24	10602	WASHER, FLAT 1/4 SAE ZINC	2
25	77546	BRACKET, BATTERY	1
26	10055	SCREW, CAP 3/8-16 X 1	1
27	10811	WASHER, LOCK 3/8 ZINC	1
28	10025	WASHER, FLAT 3/8 SAE ZINC	1
29	3611	CABLE, THROTTLE, LEVER-TYPE 54" (TRIMMED TO 44"LOA)	1
30	10877	SCREW, CAP STSHW 10-24 X 1/2	3
31	10831	WASHER, LOCK, INT. TOOTH #10	3
32	10941	CLIP, CONDUIT, THROTTLE CABLE	1



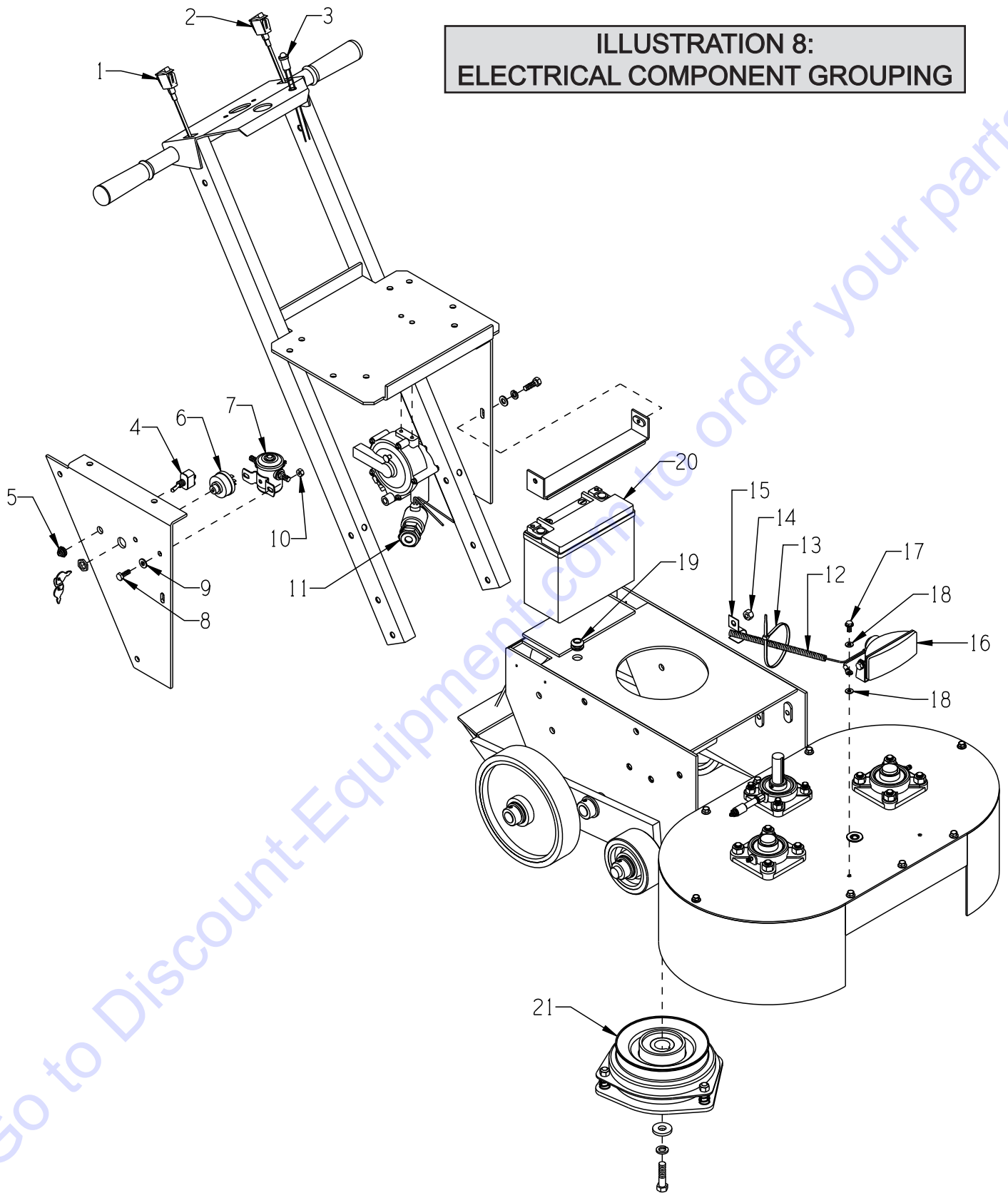
**ILLUSTRATION 7: PROPANE TANK GROUPING**



**PARTS LISTING**  
**ILLUSTRATION 7: PROPANE TANK GROUPING**

ITEM #	PART #	DESCRIPTION	QTY.
1	15130	PROPANE TANK 20LB. HORZ./VERT.	1
2	N/A	DECAL, ARROW, RED (SEE DECAL SHEET 1)	1
3	77061-1	PROPANE TANK CRADLE BRACKET ONLY	1
4	77061-2	PROPANE TANK STRAP W/ HINGE	1
5	77061-3	PROPANE TANK CLAW BRACKET	1
6	77061-4	PROPANE TANK TOGGLE CLAMP	1
7	11661	SCREW, FLAT HD SLT 1/4-20 X 1	4
8	10602	WASHER, FLAT 1/4 SAE ZINC	4
9	10861	NUT, KEPS LOCK 1/4-20 ZINC	4
10	10802	BOLT, CARRIAGE 3/8-16 X 1 ZINC	4
11	10025	WASHER, FLAT 3/8 SAE ZINC	4
12	10811	WASHER, LOCK 3/8 ZINC	4
13	10404	NUT, HEX 3/8-16 ZINC	4
14	77547	DECK, PROPANE TANK	1
15	77548	SIDE PANEL, HANDLE RIGHT	1
16	77549	SIDE PANEL, HANDLE LEFT	1
17	10021	SCREW, CAP 3/8-24 X 1	4
18	10025	WASHER, FLAT 3/8 SAE ZINC	8
19	10004	NUT, HEX LOCK 3/8-24 ZINC	4
20	10029	SCREW, CAP 3/8-24 X 1-3/4	4
21	10025	WASHER, FLAT 3/8 SAE ZINC	8
22	10004	NUT, HEX LOCK 3/8-24 ZINC	4

**ILLUSTRATION 8:  
ELECTRICAL COMPONENT GROUPING**



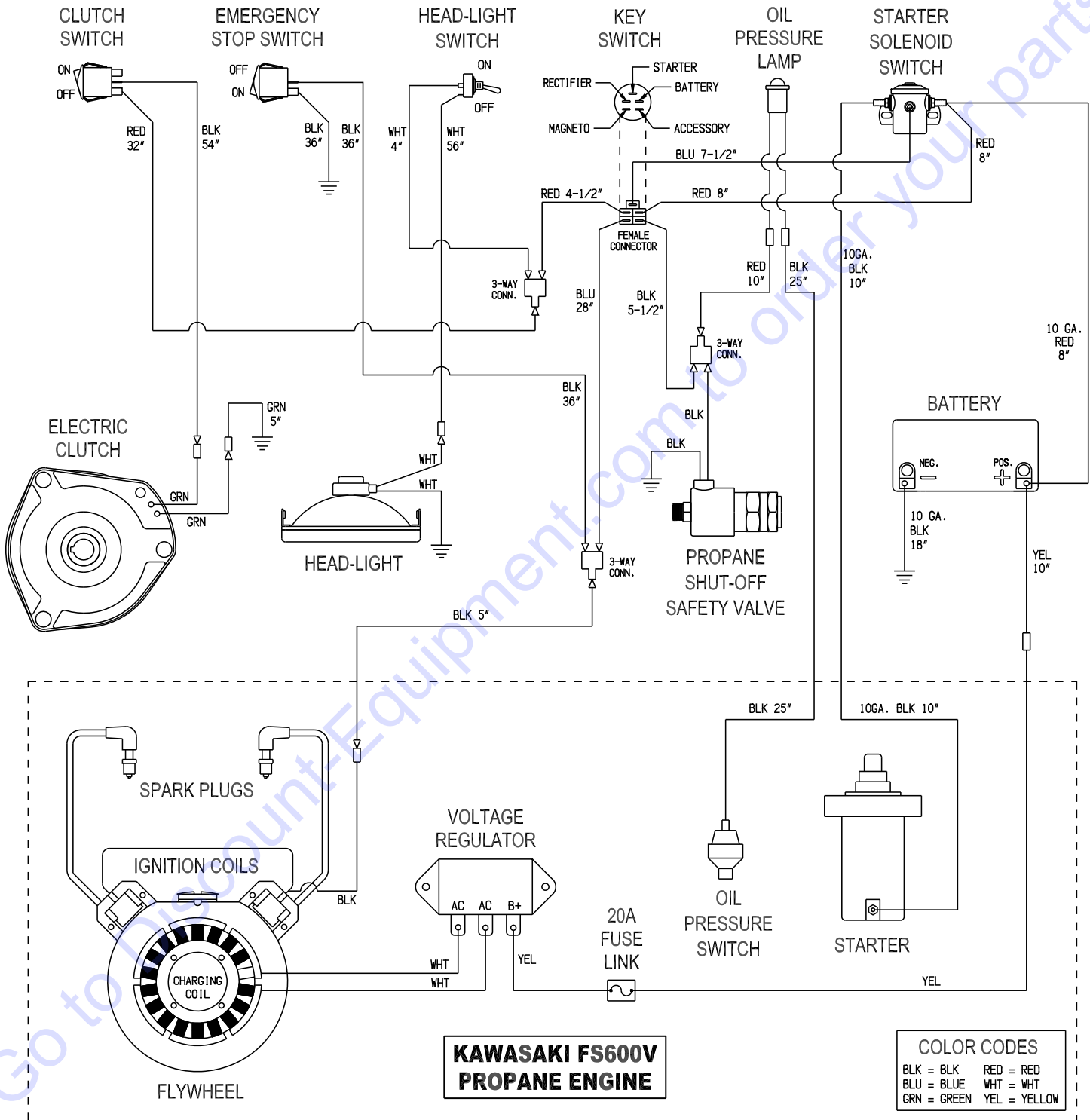
**PARTS LISTING**  
**ILLUSTRATION 8: ELECTRICAL COMPONENT GROUPING**

ITEM #	PART #	DESCRIPTION	QTY.
1	15201A	SWITCH W/ WIRES, ROCKER RED ON-OFF (EMERGENCY STOP)	1
	50084	ADDITIONAL PARTS REQ'D. (NOT SHOWN): TERM., RING #10 16-14GA. INSULATED	1
	10831	WASHER, LOCK, INT. TOOTH #10	1
	10877	SCREW, CAP STSHW 10-24 X 1/2	1
	11567	CONNECTOR, BULLET STD. 16-14GA.BLUE	1
2	75184	SWITCH, ROCKER ON-OFF, RED, CLUTCH	1
3	15264	LAMP, OIL PRESSURE, RED	1
4	10633	SWITCH, TOGGLE SPST 15/10A-115/250V	1
5	10674	BOOT, TOGGLE SWITCH	1
6	75183	SWITCH, KEY STARTER	1
7	75171	SOLENOID SWITCH, STARTER	1
8	10018	SCREW, CAP 1/4-20 X 3/4	2
9	10602	WASHER, FLAT 1/4 SAE ZINC	2
10	10861	NUT, KEPS LOCK 1/4-20 ZINC	2
11	-----	SAFETY VALVE, INLINE SHUT-OFF, AFC #152 THIS IS INCLUDED WITH THE ENGINES LP FUEL SYSTEM (REFER TO ILLUS. 7)	1
12	16550	LOOM, FLEX 1/4" X 45"	4 FT.
13	10982	TIE, CABLE, BLACK NYLON 11-1/4"	1
14	41124	CLAMP, CONDUIT 1/2"EMT (SNAP-STRAP)	1
15	10004	NUT, HEX LOCK 3/8-24 ZINC	1
16	75170	HEADLIGHT (REFER TO ILLUS. 1)	1
17	10877	SCREW, CAP STSHW 10-24 X 1/2	3
18	10831	WASHER, LOCK, INT. TOOTH #10	4
19	57148	GROMMET 3/8ID X 1/8GRV. X 5/8GD	1
20	75173	BATTERY 12V, DEKA ETX20L (REFER TO ILLUS. 6)	1
21	75182	CLUTCH, ELECTRIC, 1 GR00VE (REFER TO ILLUS. 6)	1
NOT SHOWN	75180	FUSEHOLDER, 1-30A, ATC BLADE	1
	75181	FUSE, 20A, ATC BLADE	1

# WIRING DIAGRAM

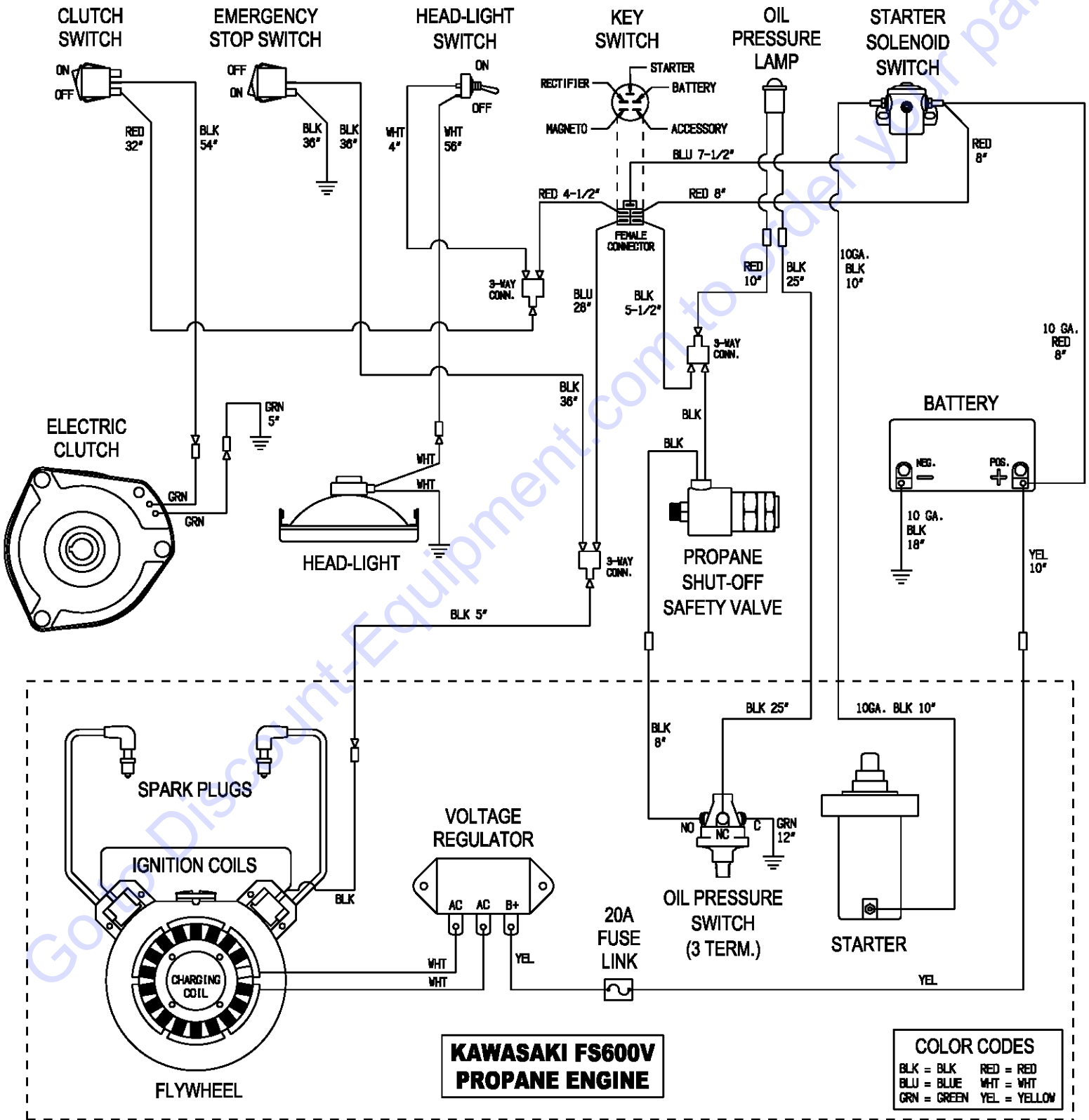
REVISED STARTING SERIAL #150410237

SELECT HERE FOR REVISED  
WIRING DIAGRAM STARTING  
S/N 151210056



# WIRING DIAGRAM FOR MODEL 2DHDP/2DP-18P

REVISED STARTING SERIAL #151210056



**KAWASAKI FS600V  
PROPANE ENGINE**

COLOR CODES	
BLK = BLK	RED = RED
BLU = BLUE	WHT = WHT
GRN = GREEN	YEL = YELLOW



# PARTS FINDER

**Search Website  
by Part Number**



**Search Manual  
Library For Parts  
Manual & Lookup Part  
Numbers – Purchase  
or Request Quote**

**Search Manuals**

Enter your information to help us find the right parts manual for your machine.

\* Brand:

\* Model:

\* Serial:

\* Part Number:

SEARCH

**Can't Find Part or  
Manual? Request Help  
by Manufacturer,  
Model & Description**

**Parts Order Form**

Please fill in the following information to help us find the right part for your machine.

Manufacturer:	<input type="text"/>
Model:	<input type="text"/>
Description:	<input type="text"/>
Part Number:	<input type="text"/>
Quantity:	<input type="text"/>
Notes:	<input type="text"/>

Submit

Discount-Equipment.com is your online resource for quality parts & equipment.

Florida: **561-964-4949** Outside Florida TOLL FREE: **877-690-3101**

**Need parts?**

Click on this link: <http://www.discount-equipment.com/category/5443-parts/> and choose one of the options to help get the right parts and equipment you are looking for. Please have the machine model and serial number available in order to help us get you the correct parts. If you don't find the part on the website or on one of the online manuals, please fill out the request form and one of our experienced staff members will get back to you with a quote for the right part that your machine needs.

We sell worldwide for the brands: Genie, Terex, JLG, MultiQuip, Mikasa, Essick, Whiteman, Mayco, Toro Stone, Diamond Products, Generac Magnum, Airman, Haulotte, Barreto, Power Blanket, Nifty Lift, Atlas Copco, Chicago Pneumatic, Allmand, Miller Curber, Skyjack, Lull, Skytrak, Tsurumi, Husquvarna Target, Stow, Wacker, Sakai, Mi-T-M, Sullair, Basic, Dynapac, MBW, Weber, Bartell, Bennar Newman, Haulotte, Ditch Runner, Menegotti, Morrison, Contec, Buddy, Crown, Edco, Wyco, Bomag, Laymor, EZ Trench, Bil-Jax, F.S. Curtis, Gehl Pavers, Heli, Honda, ICS/PowerGrit, IHI, Partner, Imer, Clipper, MMD, Koshin, Rice, CH&E, General Equipment, Amida, Coleman, NAC, Gradall, Square Shooter, Kent, Stanley, Tamco, Toku, Hatz, Kohler, Robin, Wisconsin, Northrock, Oztec, Toker TK, Rol-Air, APT, Wylie, Ingersoll Rand / Doosan, Innovatech, Con X, Ammann, Mecalac, Makinex, Smith Surface Prep, Small Line, Wanco, Yanmar