



REVISED STARTING
SERIAL # 210310050

PARTS LIST MANUAL



HEAVY-DUTY FLOOR GRINDER / POLISHER



PROPANE MODEL 2DHDP-18P
SKU # 58200

**READ AND UNDERSTAND THE OPERATOR'S SAFETY MANUAL THOROUGHLY
BEFORE ATTEMPTING TO OPERATE THIS EQUIPMENT.**

Death or serious injury could occur if this machine is used improperly.



PARTS FINDER

**Search Website
by Part Number**



**Search Manual
Library For Parts
Manual & Lookup Part
Numbers – Purchase
or Request Quote**

Search Manuals

Enter your information to search for a manual or to purchase a manual or parts.

* Brand:

* Model:

* Serial:

* Part Number:

SEARCH

**Can't Find Part or
Manual? Request Help
by Manufacturer,
Model & Description**

Parts Order Form

Please fill in the following information:

Manufacturer:

Model:

Description:

Quantity:

Part Number:

Part Name:

Part Description:

Part Category:

Part Location:

Part Status:

Part Condition:

Part Material:

Part Color:

Part Weight:

Part Dimensions:

Part Price:

Part Notes:

Submit

Discount-Equipment.com is your online resource for quality parts & equipment.

Florida: **561-964-4949** Outside Florida TOLL FREE: **877-690-3101**

Need parts?

Click on this link: <http://www.discount-equipment.com/category/5443-parts/> and choose one of the options to help get the right parts and equipment you are looking for. Please have the machine model and serial number available in order to help us get you the correct parts. If you don't find the part on the website or on one of the online manuals, please fill out the request form and one of our experienced staff members will get back to you with a quote for the right part that your machine needs.

We sell worldwide for the brands: Genie, Terex, JLG, MultiQuip, Mikasa, Essick, Whiteman, Mayco, Toro Stone, Diamond Products, Generac Magnum, Airman, Haulotte, Barreto, Power Blanket, Nifty Lift, Atlas Copco, Chicago Pneumatic, Allmand, Miller Curber, Skyjack, Lull, Skytrak, Tsurumi, Husquvarna Target, Stow, Wacker, Sakai, Mi-T-M, Sullair, Basic, Dynapac, MBW, Weber, Bartell, Bennar Newman, Haulotte, Ditch Runner, Menegotti, Morrison, Contec, Buddy, Crown, Edco, Wyco, Bomag, Laymor, EZ Trench, Bil-Jax, F.S. Curtis, Gehl Pavers, Heli, Honda, ICS/PowerGrit, IHI, Partner, Imer, Clipper, MMD, Koshin, Rice, CH&E, General Equipment, Amida, Coleman, NAC, Gradall, Square Shooter, Kent, Stanley, Tamco, Toku, Hatz, Kohler, Robin, Wisconsin, Northrock, Oztec, Toker TK, Rol-Air, APT, Wylie, Ingersoll Rand / Doosan, Innovatech, Con X, Ammann, Mecalac, Makinex, Smith Surface Prep, Small Line, Wanco, Yanmar



SAFETY INFORMATION



SAFETY MESSAGES

• Safety Instructions are preceded by a graphic alert symbol of DANGER, WARNING, or CAUTION.



Indicates an imminent hazard which, if not avoided, will result in death or serious injury.



Indicates an imminent hazard which, if not avoided, can result in death or serious injury.



Indicates hazards which, if not avoided, could result in serious injury and or damage to the equipment.

GASOLINE / PROPANE POWERED EQUIPMENT



• Engine exhaust from this product contains chemicals known to the State of California to cause cancer, birth defects or other reproductive harm.



• Tilting a gasoline powered machine fitted with an EPA approved vented charcoal filter gas cap, beyond 20° can cause fuel leakage. If a leak occurs, do not start or run the engine until the leak is fixed. Eliminate all other ignition sources in the immediate area (no smoking, flares, sparks or flames). Use approved gasoline absorbing material to contain the fuel leakage. Then use clean, non-sparking tools to collect absorbed materials then dispose of these contaminants properly.



• Gasoline is extremely flammable and poisonous. It should only be dispensed in well ventilated areas, and with a cool engine.

• Small gasoline engines produce high concentrations of carbon monoxide (CO) example: a 5 HP 4 cycle engine operation in an enclosed 100,000 cu. ft. area with only one change of air per hour is capable of providing deadly concentrations of CO in less than fifteen minutes. Five changes of air in the same area will produce noxious fumes in less than 30 minutes. Gasoline powered equipment should not be used in enclosed or partially enclosed areas. Symptoms of CO poisoning include, head-ache, nausea, weakness, dizziness, visual problems and loss of consciousness. If symptoms occur - get into fresh air and seek medical attention immediately.

- Never refuel a hot engine or an engine while it is running.
- Engines are shipped from factory without fuel/oil.



• Propane is extremely flammable and is heavier than air and tends to settle in low areas where a spark or flame could ignite gas. DO NOT start or operate this propane engine in a poorly ventilated area where leaking propane gas could accumulate and endanger safety of persons in area. If headache develops, shut off machine. Have it checked for carbon monoxide emissions by a qualified technician before using it again. To ensure personal safety, installation and repair of propane fuel supply systems must be performed only by qualified technicians. Carbon monoxide emissions from this machine are greatly increased due to a dirty combustion air cleaner.

ELECTRICAL POWERED EQUIPMENT



Extreme care must be taken when operating electric models with water present: Ensure power cord is properly grounded, is attached to a Ground-Fault-Interrupter (GFI) outlet, and is undamaged.

- Check all electrical cables - be sure connections are tight and cable is continuous and in good condition. Be sure cable is correctly rated for both the operating current and voltage of this equipment.
- Improper connection of the equipment grounding conductor can result in a risk of electric shock. Check with qualified electrician or service person if there is any doubt as to whether the outlet is properly grounded. Adhere to all local codes and ordinances.
- NOTE: In the event of a malfunction or breakdown, grounding provides a path of least resistance for the electric current to dissipate. The motor is equipped with a grounded plug and must be connected to an outlet that is properly installed and properly grounded. DO NOT modify the plug provided on the motor. If the plug does not fit the outlet have a qualified electrician install the proper receptacle.

ELECTRICAL POWERED EQUIPMENT CONTINUED

- Do not disconnect power by pulling cord. To disconnect, grasp the plug, not the cord.
- Unplug power cord at the machine when not in use and before servicing.
- Switch motor OFF before disconnecting power.
- Never use frayed, damaged, taped or under rated extension cords. Electrical shock could result in death or serious injury to the operator and damage to the equipment.
- Assure you are using the proper extension cord length.

GENERAL INSTRUCTIONS

- Equipment should only be operated by trained personnel in good physical condition and mental health (not fatigued). The operator and maintenance personnel must be physically able to handle the bulk weight and power of this equipment.
- This is a one person tool. Maintain a safe operating distance to other personnel. It is the operators' responsibility to keep other people (workers, pedestrians, bystanders, etc.) away during operation. Block off the work area in all directions with roping, safety netting, etc. Failure to do so may result in others being injured by flying debris or exposing them to harmful dust and noise.
- This equipment is intended for commercial use only.
- For the operator's safety and the safety of others, always keep all guards in place during operation.
- Never let equipment run unattended.



- Personal Protection Equipment and proper safety attire must be worn when operating this machinery. The operator must wear approved safety equipment appropriate for the job such as hard hat and safety shoes when conditions require. Hearing protection **MUST** be used when operational noise levels of this equipment may exceed 85db. Eye protection **MUST** be worn at all times.



Keep body parts, loose clothing and accessories away from moving parts. Failure to do so could result in dismemberment or death.

- Do not modify the machine.
- Stop motor/engine when adjusting or servicing this equipment. Maintain a safe operating distance from flammable materials. Sparks from the cutting-action of this machine can ignite flammable materials or vapors.



DUST WARNING



Some dust created by power sanding, sawing, grinding, drilling, and other construction activities contains chemicals known to cause cancer, birth defects, or other reproductive harm. Materials being removed can be toxic or hazardous. A breathing respirator is required to help protect the operator.

Some examples of these chemicals are:

- Lead from lead-based paints.
- Crystalline silica from bricks, concrete and other masonry products. Your risk of exposure to these chemicals varies depending on how often you do this type of work. To reduce your risk: work in a well ventilated area, use a dust control system, such as an industrial-style vacuum, and wear approved personal safety equipment, such as a dust/particle respirator designed to filter out microscopic particles.
- See more on the importance of dust prevention and silica warnings at: osha.gov/silica



HEAVY-DUTY FLOOR GRINDER/POLISHER

PROPANE MODEL

TABLE OF CONTENTS

<u>Section</u>	<u>Page Number</u>
Safety Messages and General Instructions	2
How To Order Replacement Parts	3
Illustration 1: Main Grouping	4, 5
Illustration 2: Handle & Wheel Carriage Grouping	6, 7
Illustration 3: Skirt, Vacuum Port & Water Hook-Up Grouping	8, 9
Illustration 4: Standard Grinding Disc Assembly	10
Illustration 5: Optional Polishing Disc Assembly	11
Illustration 6: Propane Engine & Belt Drive Grouping	12, 13
Illustration 7: Propane Tank Grouping	14, 15
Illustration 8: Electrical Component Grouping	16, 17
Wiring Diagram	18
Key Switch Wire Harness	19
Other Wire Assemblies	20
Decal Sheet 1	21
Decal Sheet 2	22
Limited Equipment Warranty of Sale - Terms & Conditions	23
STOP: Before Using this Product	24

**ILLUSTRATION 1:
MAIN GROUPING**

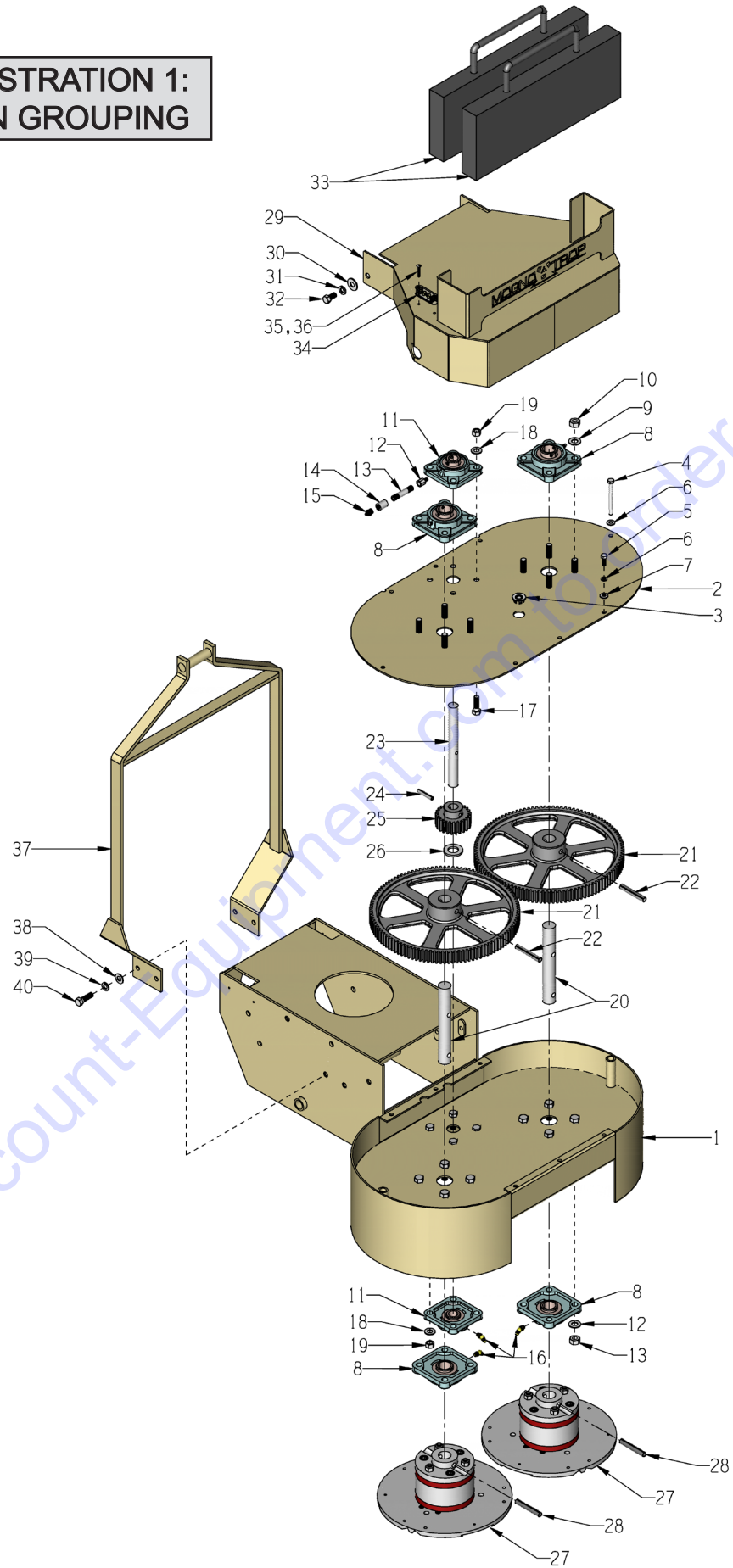

PARTS LISTING - ILLUSTRATION 1 : MAIN GROUPING			
ITEM #	PART #	DESCRIPTION	QTY.
1	77501	MAIN FRAME	1
2	77502	COVER, GEAR CASE	1
3	10005	PLUG, HOLE 7/8" BRIGHT ZINC	1
4	11697	SCREW, FLANGE HEX 1/4-20 X 3	2
5	10018	SCREW, CAP 1/4-20 X 3/4	6
6	10038	WASHER, LOCK 1/4 ZINC	8
7	10602	WASHER, FLAT 1/4 SAE ZINC	6
8	77008	BEARING, BALL 1" 4-HOLE FLANGE, ND	4
9	10450	WASHER, LOCK 7/16 ZINC	16
10	10481	NUT, HEX 7/16-20 ZINC	16
11	77009	BEARING, BALL 3/4" 4-HOLE FLANGE	2
12	50541	ADAPTER, GREASE FIT. 1/8PT X 1/4-28	1
13	10699	PIPE NIPPLE 1/8NPT X 2" (BLACK)	1
14	10585	PIPE COUPLING 1/8 NPT (BLACK STEEL)	1
15	10953	FITTING, GREASE 1/8 NPT STRAIGHT	1
16	10960	FITTING, GREASE 1/4-28 X 45°	3
17	10309	SCREW, CAP 3/8-24 X 1-1/4 ZINC	4
18	10811	WASHER, LOCK 3/8 ZINC	4
19	10014	NUT, HEX 3/8-24 ZINC	4
20	77346	SHAFT, LARGE GEAR 1"DIA X 7"L	2
21	77012	GEAR, SPUR 112 TOOTH (DRIVEN)	2
22	63056	PIN, H.D.COILED SPRING 3/8 X 2-1/2	2
23	77011	SHAFT, PINION GEAR 3/4DIA X 7-3/8"L	1
24	10037	PIN, ROLL 1/4 X 1-1/2	1
25	77053	GEAR, SPUR 25 TOOTH (PINION)	1
26	10009	WASHER, FLAT 3/4 SAE ZINC	1
27	101201	MT GRINDING DISC ASSEMBLY (REFER TO ILLUSTRATION 4 FOR BREAKDOWN)	2
28	10007	PIN, ROLL 3/8 X 2-1/2	2
29	100961	HOOD, PROPANE MODEL	1
30	10025	WASHER, FLAT 3/8 SAE ZINC	2
31	10811	WASHER, LOCK 3/8 ZINC	2
32	10907	SCREW, CAP 3/8-16 X 3/4	2
33	77506	WEIGHT BLOCK, 40 LB.	2
34	59117	LEVEL, SCREW ON	1
35	11871	SCREW, MACHINE FHP 8-32 X 1-1/4	2
36	10462	NUT, KEPS LOCK 8-32 ZINC (NOT SHOWN)	2
37	77532	LIFTING BAIL	1
38	10025	WASHER, FLAT 3/8 SAE ZINC	4
39	10811	WASHER, LOCK 3/8 ZINC	4
40	10309	SCREW, CAP 3/8-24 X 1-1/4 ZINC	4

**ILLUSTRATION 2:
HANDLE & WHEEL CARRIAGE GROUPING**

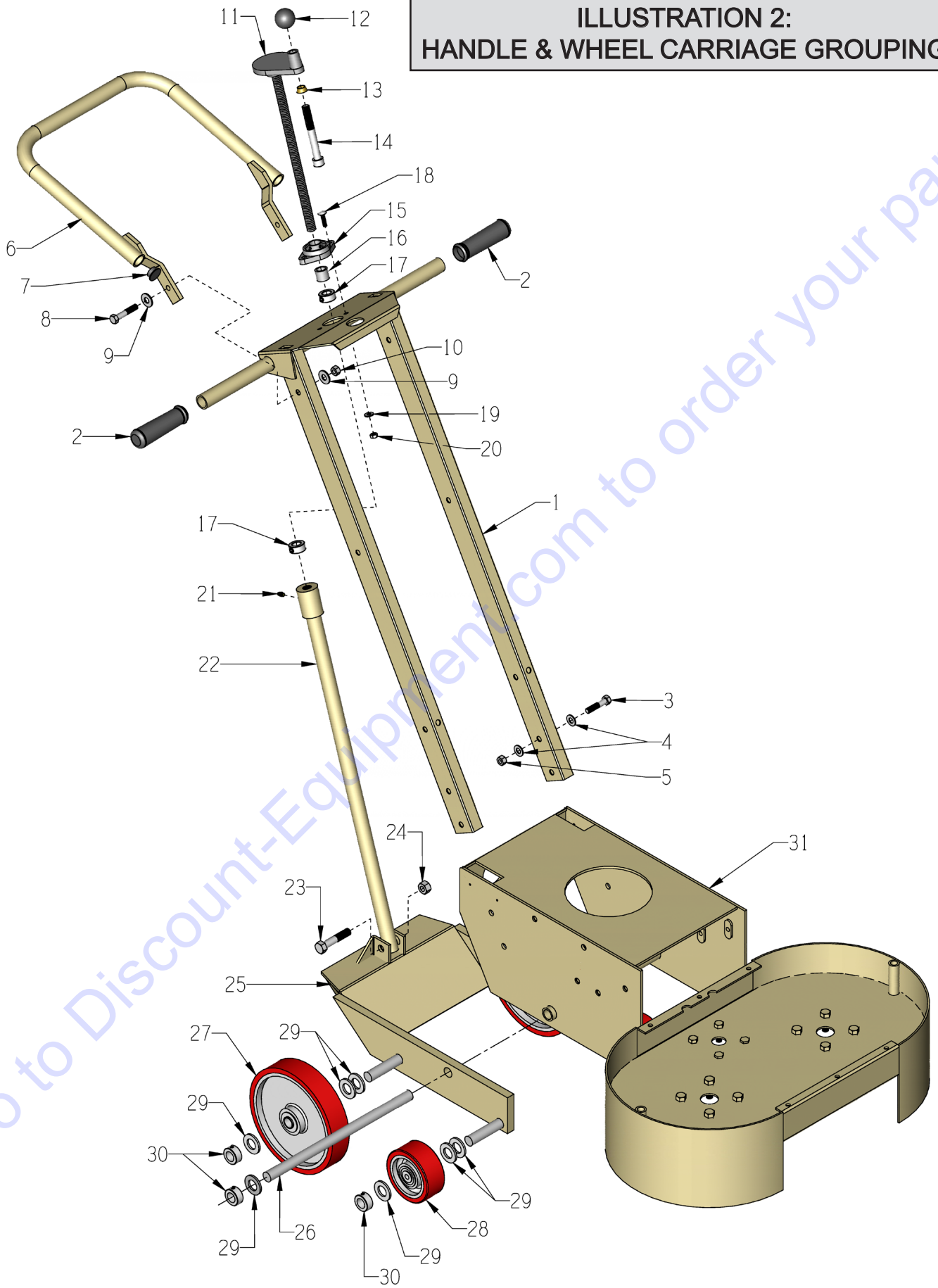

PARTS LISTING - ILLUSTRATION 2 : HANDLE & WHEEL CARRIAGE GROUPING			
ITEM #	PART #	DESCRIPTION	QTY.
1	77533	HANDLE BAR, PROPANE MODEL	1
2	10608	GRIP, HAND 1" MODEL AT	2
3	10029	SCREW, CAP 3/8-24 X 1-3/4	4
4	10025	WASHER, FLAT 3/8 SAE ZINC	8
5	10004	NUT, HEX LOCK 3/8-24 ZINC	4
6	77508	HANDLE EXTENSION	1
7	77528	PLUG, BLACK 1"RD. TUBING 10-14 GA.	2
8	10030	SCREW, CAP 3/8-24 X 2	2
9	10025	WASHER, FLAT 3/8 SAE ZINC	4
10	10004	NUT, HEX LOCK 3/8-24 ZINC	2
11	65019	HANDWHEEL, SMALL W/ 5/8-8 X 13"ROD	1
12	14023	KNOB, BALL 1-3/8 W/ 1/2-13THD, BLK.	1
13	50550	SLEEVE, BRASS 1/2" TAPERED	1
14	10346	SCREW, SKT. HD. CAP 1/2-13 X 4-1/2	1
15	80009	BEARING, BALL 5/8" 2-HOLE (NO G.F.)	1
16	55010	SPACER, HANDWHEEL 5/8"ID X 3/4"L	1
17	10096	COLLAR, LOCKING 5/8"ID	2
18	10412	BOLT, CARRIAGE 1/4-20 X 1	2
19	10602	WASHER, FLAT 1/4 SAE ZINC	2
20	10861	NUT, KEPS LOCK 1/4-20 ZINC	2
21	10808	FITTING, GREASE 1/4-28 STRAIGHT	1
22	77534	LINKAGE, LOWER	1
23	10343	SCREW, CAP 1/2-20 X 2-1/2	1
24	10154	NUT, HEX NYLON LOCK 1/2-20 ZINC	1
25	77510	CARRIAGE, WHEEL	1
26	77537	FORK SHAFT 3/4"DIA. X 13-3/4"L	1
27	68008	WHEEL 8 X 1-5/8 X 3/4"BRG., POLY	2
28	77520	WHEEL 4 X 1-1/2 X 3/4"BRG., POLY	2
29	10009	WASHER, FLAT 3/4 SAE ZINC	14
30	10428	COLLAR, LOCKING 3/4"ID	6
31	77501	MAIN FRAME (REFER TO ILLUS. 1)	1

ILLUSTRATION 3: SKIRT, VACUUM PORT & WATER HOOK-UP GROUPING

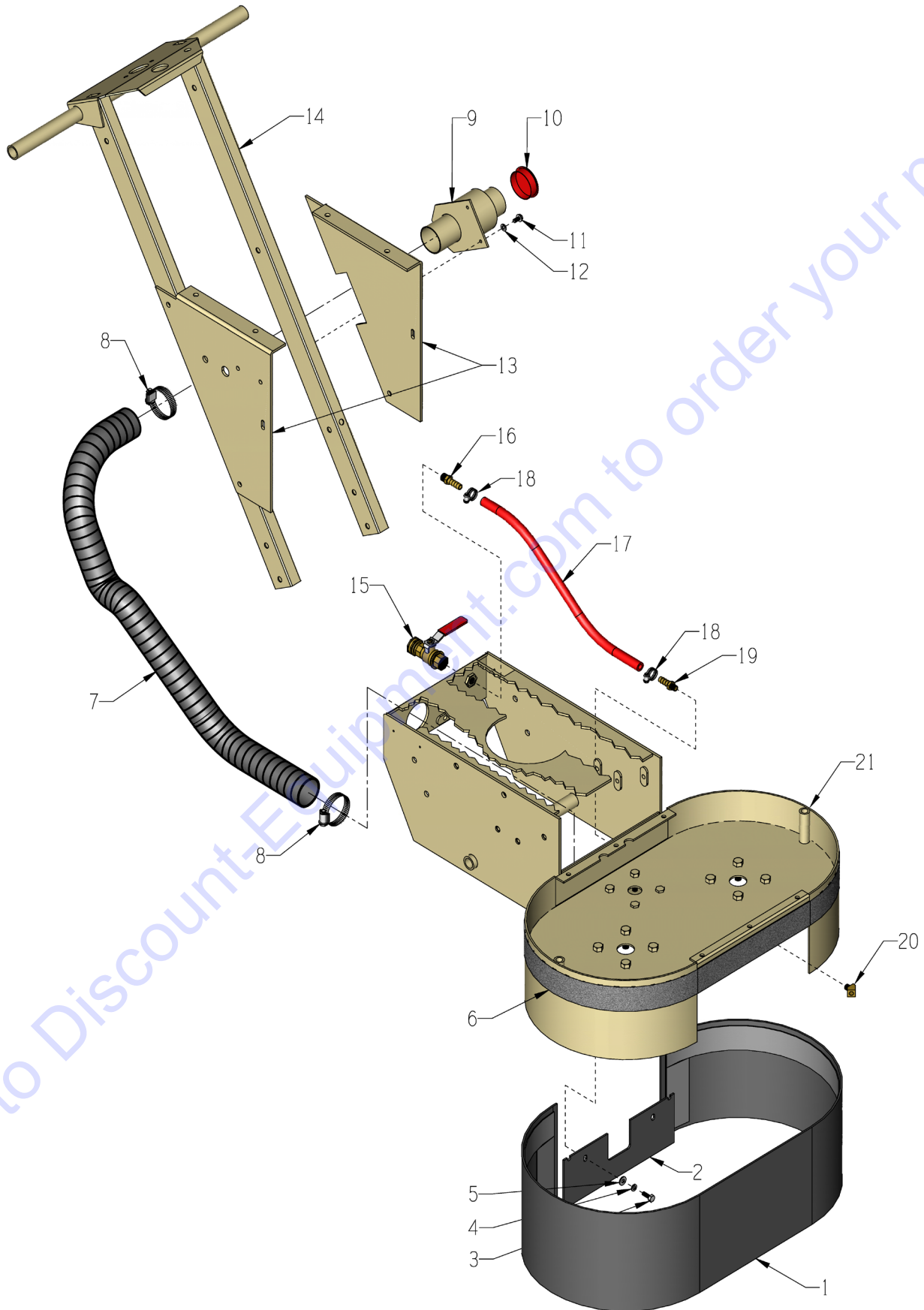

PARTS LISTING - ILLUSTRATION 3 :			
SKIRT, VACUUM PORT & WATER HOOK-UP GROUPING			
ITEM #	PART #	DESCRIPTION	QTY.
1	77529	RUBBER SKIRT 1/8 X 8 X 58 W/VELCRO	1
2	77504	RUBBER SKIRT, REAR 1/8 X 4 X 11	1
3	10018	SCREW, CAP 1/4-20 X 3/4	2
4	10038	WASHER, LOCK 1/4 ZINC	2
5	10602	WASHER, FLAT 1/4 SAE ZINC	2
6	77556	VELCRO-HOOK ONLY 2" X 72" 1 PIECE CUT 57-1/4"L & 2 PIECES CUT 4-1/2"L	1
7	77551	HOSE, FLEX 2"ID X 36"L	1
8	10766	CLAMP, HOSE, SAE #32, ADJ. TO 2-1/2	2
9	77538	VACUUM PORT	1
10	65021	CAP/PLUG 2" RED PLASTIC, FLANGED	1
11	10846	SCREW, CAP STSHW 1/4-20 X 1/2	2
12	10038	WASHER, LOCK 1/4 ZINC	2
13	-----	SIDE PANELS, HANDLE (REFER TO ILLUS. 7)	2
14	77533	HANDLE BAR, PROP. MODEL (REFER TO ILLUS. 2)	1
15	10711A	VALVE & HOSE CONNECTOR ASSY.	1
16	50075	BARB, 3/8 HOSE X 1/4MPT (BRASS)	1
17	77521	HOSE 3/8"ID X 18"L	1
18	10714	CLAMP, HOSE, SAE #4, ADJ. TO 5/8"	2
19	10694	BARB, 3/8HOSE X 1/8MPT	1
20	10772	ELBOW, STREET 1/8NPT X 45 (BRASS)	1
21	77501	MAIN FRAME (REFER TO ILLUS. 1)	1

PARTS FINDER

**Search Website
by Part Number**



**Search Manual
Library For Parts
Manual & Lookup Part
Numbers – Purchase
or Request Quote**

Search Manuals

Enter your information to help us find the right parts manual for your machine.

* Brand:

* Model:

* Serial:

* Part Number:

SEARCH

**Can't Find Part or
Manual? Request Help
by Manufacturer,
Model & Description**

Parts Order Form

Please fill in the following information to help us find the right part for your machine.

Manufacturer:	<input type="text"/>
Model:	<input type="text"/>
Description:	<input type="text"/>
Part Number:	<input type="text"/>
Quantity:	<input type="text"/>
Notes:	<input type="text"/>

Submit

Discount-Equipment.com is your online resource for quality parts & equipment.

Florida: **561-964-4949** Outside Florida TOLL FREE: **877-690-3101**

Need parts?

Click on this link: <http://www.discount-equipment.com/category/5443-parts/> and choose one of the options to help get the right parts and equipment you are looking for. Please have the machine model and serial number available in order to help us get you the correct parts. If you don't find the part on the website or on one of the online manuals, please fill out the request form and one of our experienced staff members will get back to you with a quote for the right part that your machine needs.

We sell worldwide for the brands: Genie, Terex, JLG, MultiQuip, Mikasa, Essick, Whiteman, Mayco, Toro Stone, Diamond Products, Generac Magnum, Airman, Haulotte, Barreto, Power Blanket, Nifty Lift, Atlas Copco, Chicago Pneumatic, Allmand, Miller Curber, Skyjack, Lull, Skytrak, Tsurumi, Husquvarna Target, Stow, Wacker, Sakai, Mi-T-M, Sullair, Basic, Dynapac, MBW, Weber, Bartell, Bennar Newman, Haulotte, Ditch Runner, Menegotti, Morrison, Contec, Buddy, Crown, Edco, Wyco, Bomag, Laymor, EZ Trench, Bil-Jax, F.S. Curtis, Gehl Pavers, Heli, Honda, ICS/PowerGrit, IHI, Partner, Imer, Clipper, MMD, Koshin, Rice, CH&E, General Equipment, Amida, Coleman, NAC, Gradall, Square Shooter, Kent, Stanley, Tamco, Toku, Hatz, Kohler, Robin, Wisconsin, Northrock, Oztec, Toker TK, Rol-Air, APT, Wylie, Ingersoll Rand / Doosan, Innovatech, Con X, Ammann, Mecalac, Makinex, Smith Surface Prep, Small Line, Wanco, Yanmar

**ILLUSTRATION 4:
STANDARD GRINDING DISC ASSEMBLY**

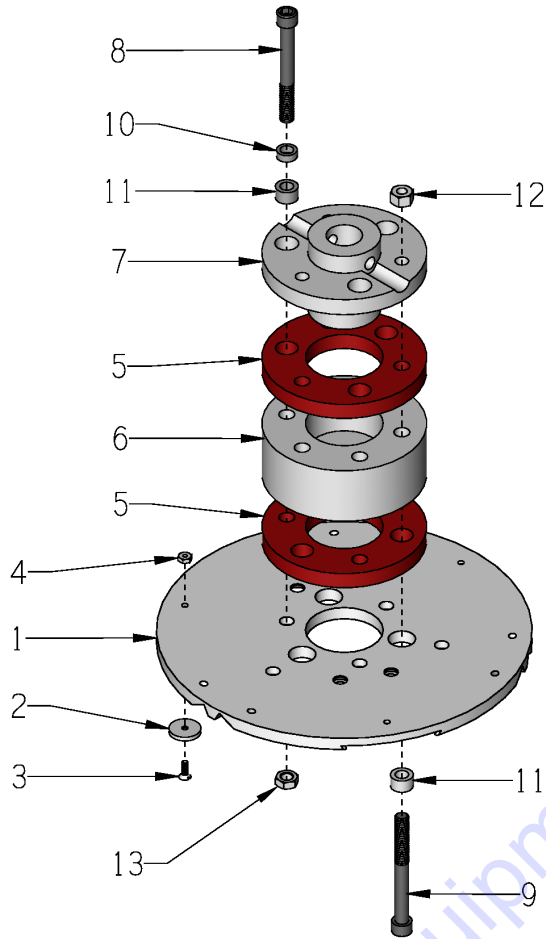

DISC ARRANGEMENT

INSTALL DISC IN OPPOSITE DIRECTIONS SO THEY PASS EACH OTHER AT THE CENTER IN ALTERNATING SEQUENCE.

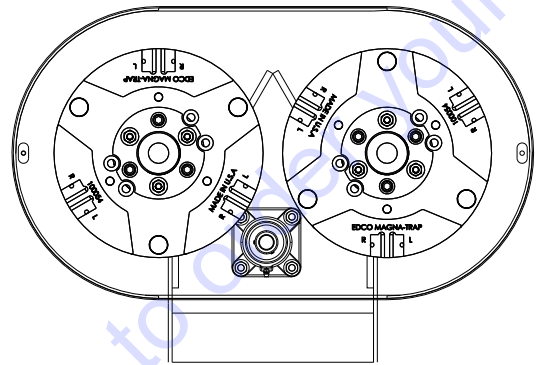

BOTTOM VIEW

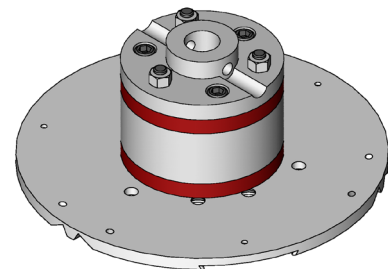

PART # 101201

ITEM #	PART #	DESCRIPTION	QTY.*
1-13	101201	MT GRINDING DISC ASSEMBLY	1
1	100054	10" UNIVERSAL MAGNA-TRAP DISC (INCLUDES MAGNETS)	1
2	36064	MAGNET, NEODYMIUM RING 7/8 X 1/8 (BOLT ON REPLACEMENT)	3
3	10647	SCREW, FLAT HD PHILLIPS 8-32 X 1/2	3
4	10462	NUT, KEPS LOCK 8-32 ZINC	3
5	100055	RING, RUBBER, 4-1/2"OD X 1/2"THK	2
6	100985	HUB SPACER, MAGNA-TRAP DISC, 2DHD	1
7	100057	HUB, GRINDER DISC	1
8	11855	SCREW, SKT. HD. CAP 3/8-24 X 3-1/4	3
9	11856	SCREW, SKT. HD. CAP 3/8-24 X 3-1/2	3
10	10113	SPACER, STEEL 9/16OD X 3/8ID X 7/32	3
11	10011	SPACER, STEEL 5/8OD X 3/8ID X 3/8T	6
12	10004	NUT, HEX LOCK 3/8-24 LOCK (USE RED LOCTITE)	3
13	11725	NUT, HEX JAM 3/8-24 ZINC (USE RED LOCTITE)	3

*NOTE: QUANTITIES ARE BASED ON 1 DISC. 2 DISC ARE REQUIRED.

ILLUSTRATION 5: OPTIONAL POLISHING DISC ASSEMBLY

E-2DHDP18P-PL-0521



DISC ARRANGEMENT

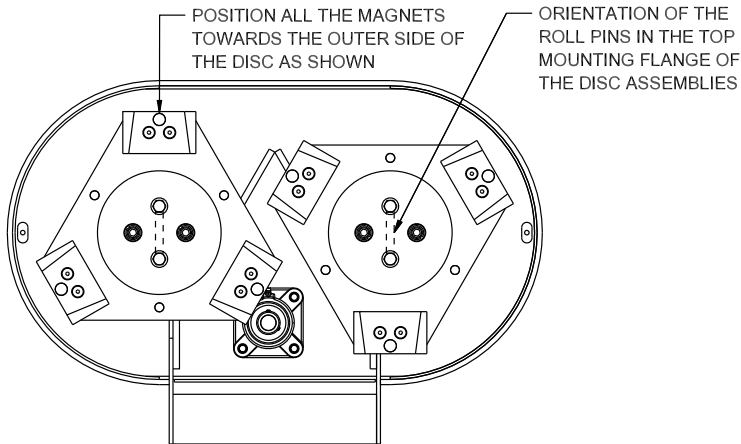

BOTTOM VIEW

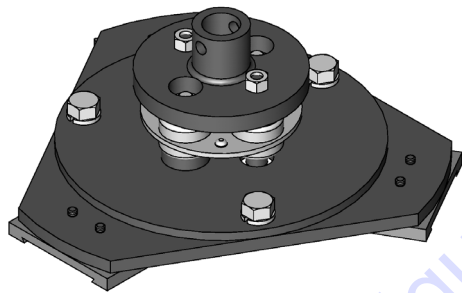

PART # 77535

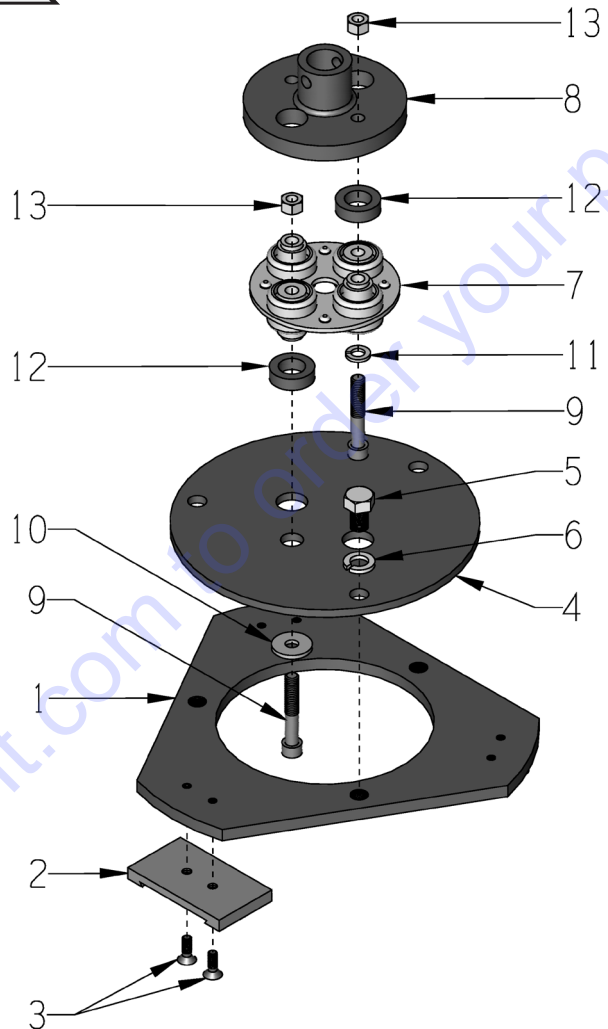

ITEM #	PART #	DESCRIPTION	QTY.*
1-13	77535	MT POLISHING DISC ASSEMBLY	1
1	75175	DISC ONLY, POLISHING, 2DHD	1
2	QC-HOLDER-EDCO	HOLDER, MAGNETIC QUICK CHANGE	3
3	10147	SCREW, FLAT HD SKT 1/4-20 X 3/4	6
4	L18567	DISC TOP PLATE, POLISHING	1
5	11614	SCREW, CAP 1/2-20 X 3/4	3
6	10045	WASHER, LOCK 1/2 ZINC	3
7	86017	COUPLING, MORFLEX 402 CENTER	1
8	77518	FLANGE, MORFLEX COUPLING	1
9	10114	SCREW, SKT. HD. CAP 3/8-24 X 2-1/4	4
10	11695	WASHER, 1.1210 X .3750 X .1280	2
11	10811	WASHER, LOCK 3/8 ZINC	2
12	86343	BUSHING, RUBBER 1-1/4 X 3/4 X 3/8	4
13	10004	NUT, HEX LOCK 3/8-24 ZINC	4

*NOTE: QUANTITIES ARE BASED ON 1 DISC. 2 DISC ARE REQUIRED.

ILLUSTRATION 6: PROPANE ENGINE & BELT DRIVE GROUPING

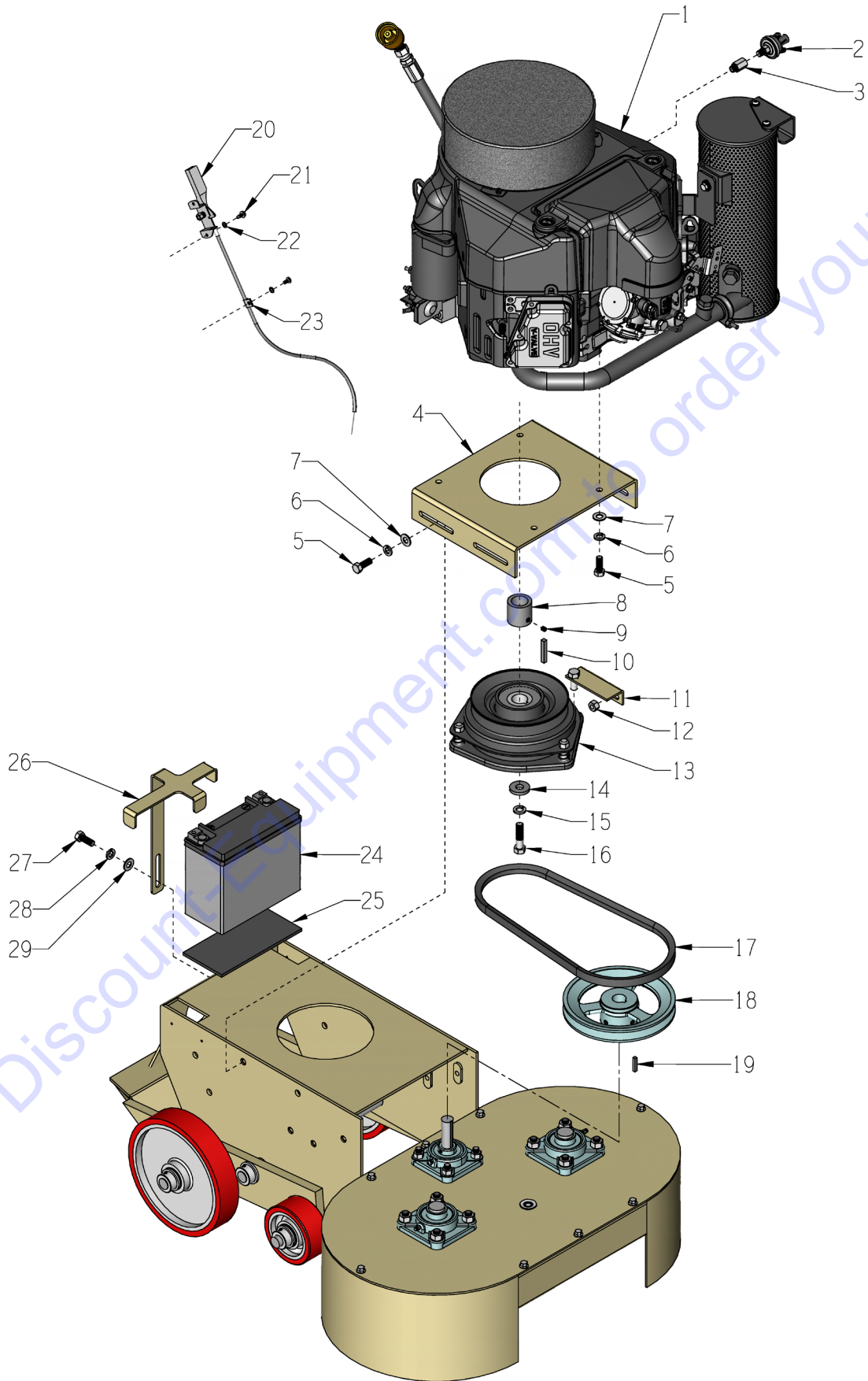

PARTS LISTING - ILLUSTRATION 6 : PROPANE ENGINE & BELT DRIVE GROUPING

ITEM #	PART #	DESCRIPTION	QTY.
1	15081	ENGINE, KAWASAKI LX600 PROP. READY INCLUDES: 12V STARTER, OIL PRESSURE SWITCH, OIL DRAIN, CATALYTIC MUFFLER. LP FUEL SYSTEM: REGULATOR, INLINE SHUT-OFF VALVE, HIGH & LOW PRESSURE HOSES, & REGO TANK CONNECTOR.	1
2	15295	SWITCH, OIL PRESSURE, 3 POLE	1
3	15296	ADAPTER 1/8-27 FNPT TO 1/8-28 BSP	1
4	77539	MOUNT, ENGINE, PROPANE	1
5	10055	SCREW, CAP 3/8-16 X 1	8
6	10811	WASHER, LOCK 3/8 ZINC	8
7	10025	WASHER, FLAT 3/8 SAE ZINC	8
8	77540	SPACER, CLUTCH, PROPANE MODEL	1
9	10139	SCREW, SET 1/4-20 X 5/16	1
10	40317	KEY 1/4SQ X 1-5/8	1
11	77541	BRACKET, CLUTCH RETAINER	1
12	10004	NUT, HEX LOCK 3/8-24 ZINC	2
13	75182	CLUTCH, ELECTRIC, 1 GR00VE	1
14	77542	WASHER, CLUTCH RETAINING 1-1/4"OD X 1/2"ID X 3/16"THK	1
15	10450	WASHER, LOCK 7/16 ZINC	1
16	11699	SCREW, CAP 7/16-20 X 1-3/4	1
17	10277	BELT B-38	1
18	10549	SHEAVE 7"OD X 1GR.B X 3/4"BORE	1
19	10016	KEY 3/16SQ X 1-1/2	1
20	3611	CABLE, THROTTLE, LEVER-TYPE 54" (TRIMMED TO 44"LOA)	1
21	10877	SCREW, CAP STSHW 10-24 X 1/2	3
22	10831	WASHER, LOCK, INT. TOOTH #10	3
23	10941	CLIP, CONDUIT, THROTTLE CABLE	1
24	75173	BATTERY 12V, INTERSTATE FAYTX20HL	1
25	77543	RUBBER PAD, BATTERY 3/16 X 3-3/8 X 7	1
26	77555	CLAMP, BATTERY HOLD-DOWN	1
27	10055	SCREW, CAP 3/8-16 X 1	1
28	10811	WASHER, LOCK 3/8 ZINC	1
29	10025	WASHER, FLAT 3/8 SAE ZINC	1

ILLUSTRATION 7: PROPANE TANK GROUPING

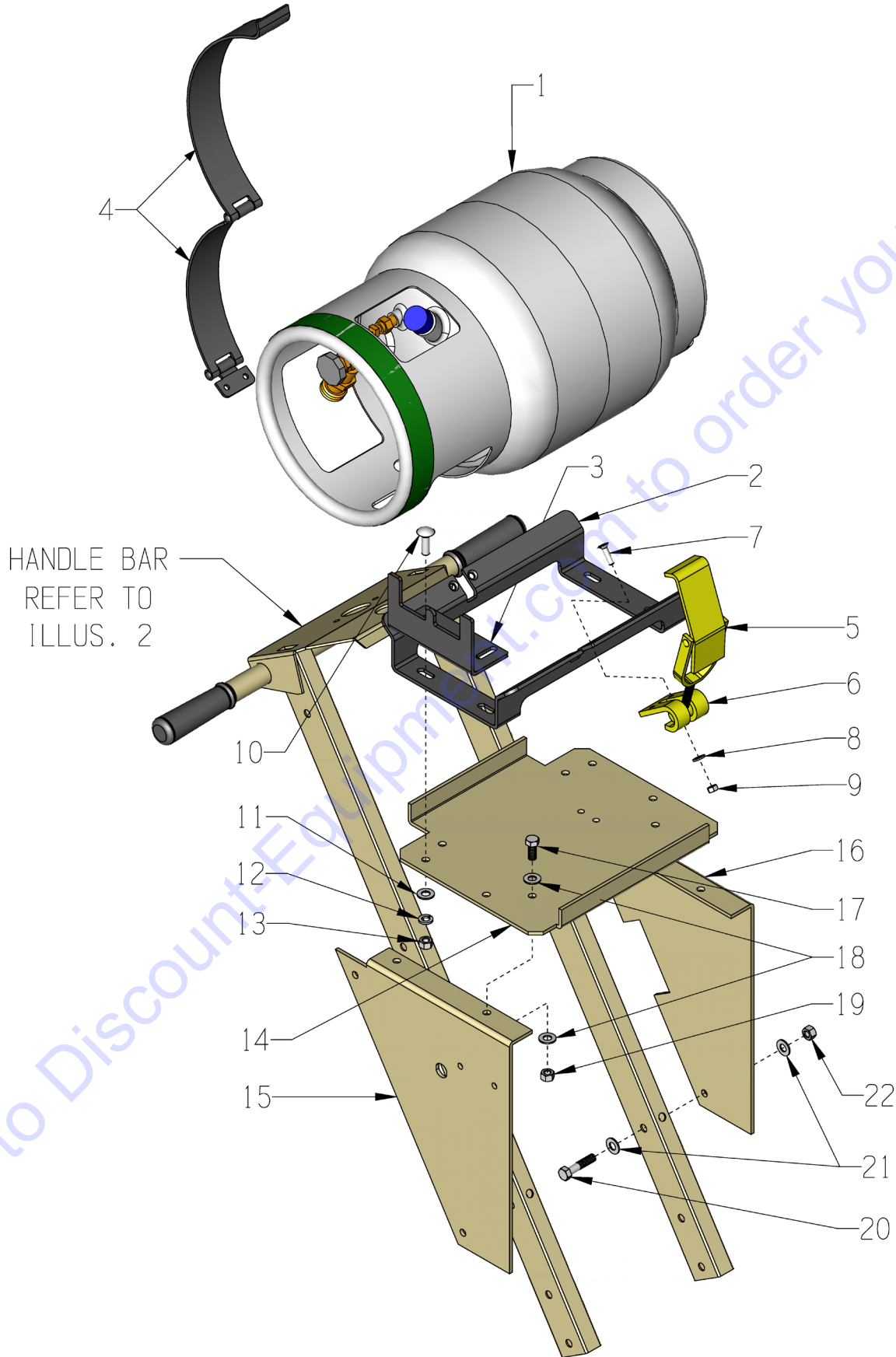

PARTS LISTING
ILLUSTRATION 7: PROPANE TANK GROUPING

ITEM #	PART #	DESCRIPTION	QTY.
1	15099	PROPANE TANK 20LB. VAPOR	1
2	100399	PROPANE TANK CRADLE BRACKET	1
3	101126	PROPANE TANK LOCATOR BRACKET	1
4	77061-2	PROPANE TANK STRAP W/ HINGE	1
5	77061-3	PROPANE TANK CLAW BRACKET	1
6	77061-4	PROPANE TANK TOGGLE CLAMP	1
7	11661	SCREW, FLAT HD SLT 1/4-20 X 1	4
8	10602	WASHER, FLAT 1/4 SAE ZINC	4
9	10861	NUT, KEPS LOCK 1/4-20 ZINC	4
10	10320	BOLT, CARRIAGE 3/8-16 X 1-1/4 ZINC	2
	10802	BOLT, CARRIAGE 3/8-16 X 1 ZINC	2
11	10025	WASHER, FLAT 3/8 SAE ZINC	4
12	10811	WASHER, LOCK 3/8 ZINC	4
13	10404	NUT, HEX 3/8-16 ZINC	4
14	77547	DECK, PROPANE TANK	1
15	100965	SIDE PANEL, HANDLE RIGHT	1
16	77549	SIDE PANEL, HANDLE LEFT	1
17	10021	SCREW, CAP 3/8-24 X 1	4
18	10025	WASHER, FLAT 3/8 SAE ZINC	8
19	10004	NUT, HEX LOCK 3/8-24 ZINC	4
20	10029	SCREW, CAP 3/8-24 X 1-3/4	4
21	10025	WASHER, FLAT 3/8 SAE ZINC	8
22	10004	NUT, HEX LOCK 3/8-24 ZINC	4

**ILLUSTRATION 8:
ELECTRICAL COMPONENT GROUPING**

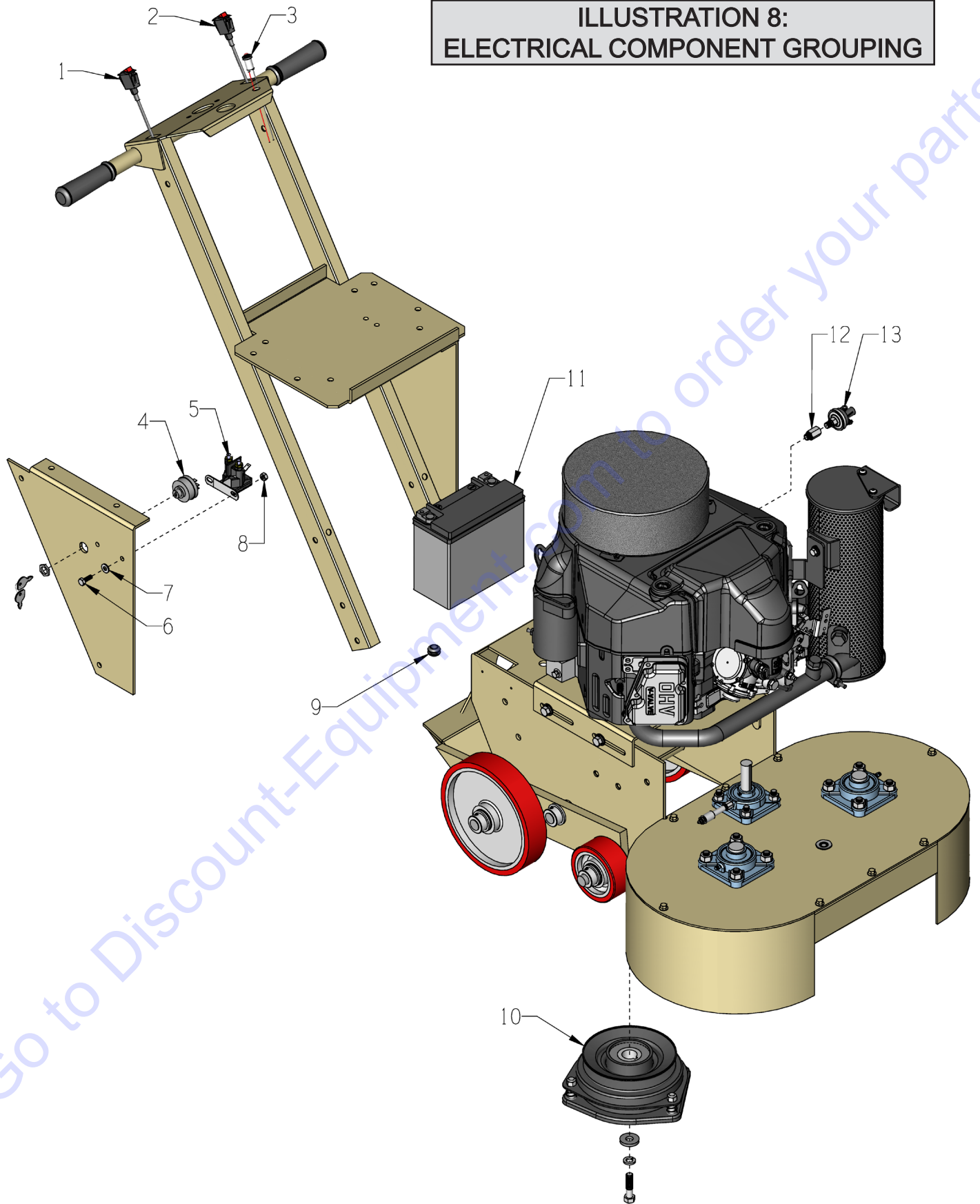

PARTS LISTING			
ILLUSTRATION 8: ELECTRICAL COMPONENT GROUPING			
ITEM #	PART #	DESCRIPTION	QTY.
1	15201A	SWITCH W/ WIRES, ROCKER RED ON-OFF (EMERGENCY STOP)	1
	50084	ADDITIONAL PARTS REQ'D. (NOT SHOWN): TERM., RING #10 16-14GA. INSULATED	1
	10831	WASHER, LOCK, INT. TOOTH #10	1
	10877	SCREW, CAP STSHW 10-24 X 1/2	1
	11567	CONNECTOR, BULLET STD. 16-14GA.BLUE	1
2	75184	SWITCH, ROCKER ON-OFF, RED, CLUTCH	1
3	15264	LAMP, OIL PRESSURE, RED	1
4	75183	SWITCH, KEY STARTER	1
5	75171	SOLENOID SWITCH, STARTER	1
6	10018	SCREW, CAP 1/4-20 X 3/4	2
7	10602	WASHER, FLAT 1/4 SAE ZINC	2
8	10861	NUT, KEPS LOCK 1/4-20 ZINC	2
9	57148	GROMMET 3/8ID X 1/8GRV. X 5/8GD	1
10	75182	CLUTCH, ELECTRIC, 1 GR00VE (REFER TO ILLUS. 6)	1
11	75173	BATTERY 12V, INTERSTATE FAYTX20HL (REFER TO ILLUS. 6)	1
12	15296	ADAPTER 1/8-27 FNPT TO 1/8-28 BSP	1
13	15295	SWITCH, OIL PRESSURE, 3 POLE	1
NOT SHOWN	75180	FUSEHOLDER, 1-30A, ATC BLADE	1
	75181	FUSE, 20A, ATC BLADE	1

WIRING DIAGRAM

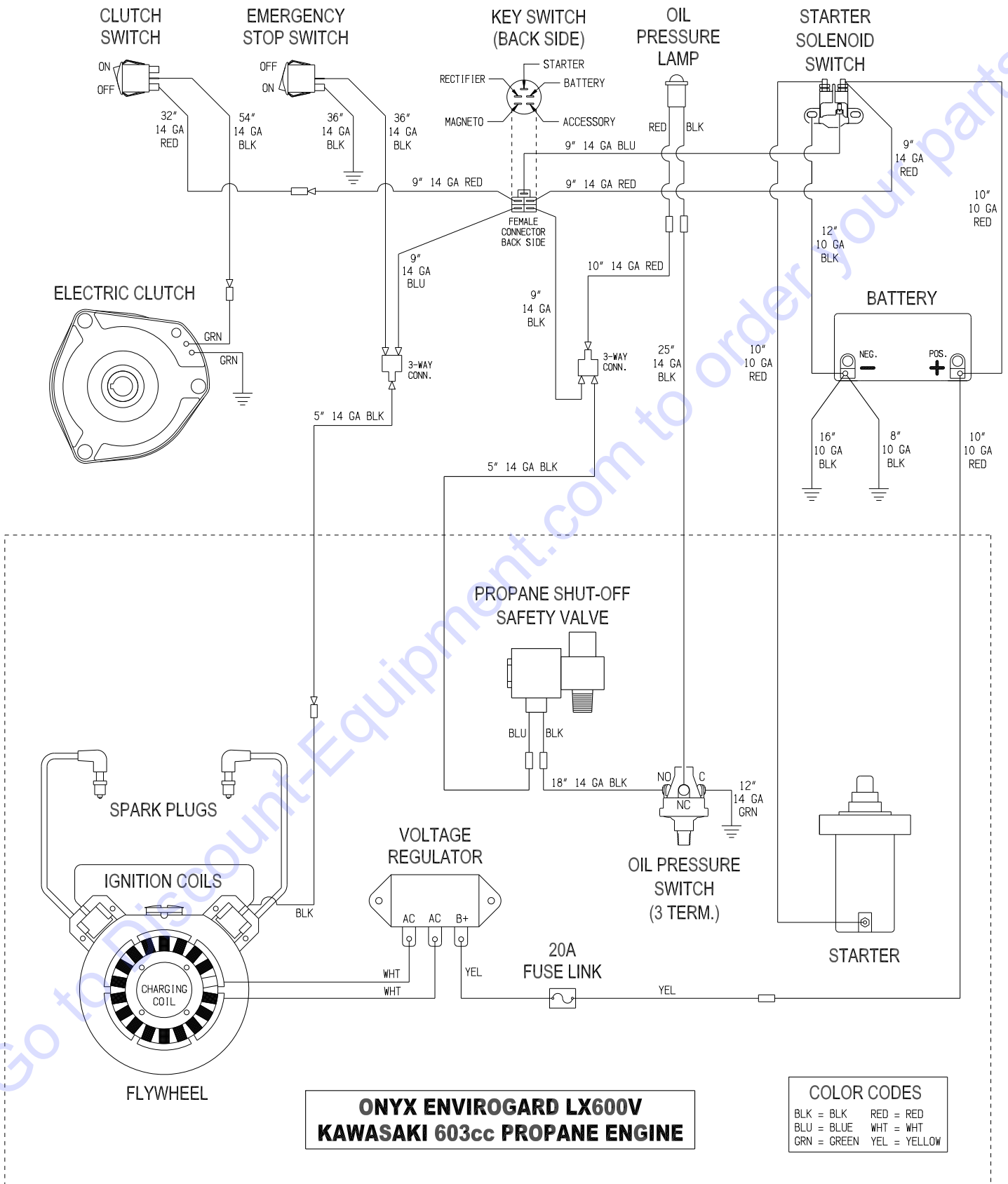

KEY SWITCH WIRE HARNESS

PART # 300104

51049 5-WAY FEMALE CONNECTOR
 10675 TERMINAL, FEMALE (QTY. 5)

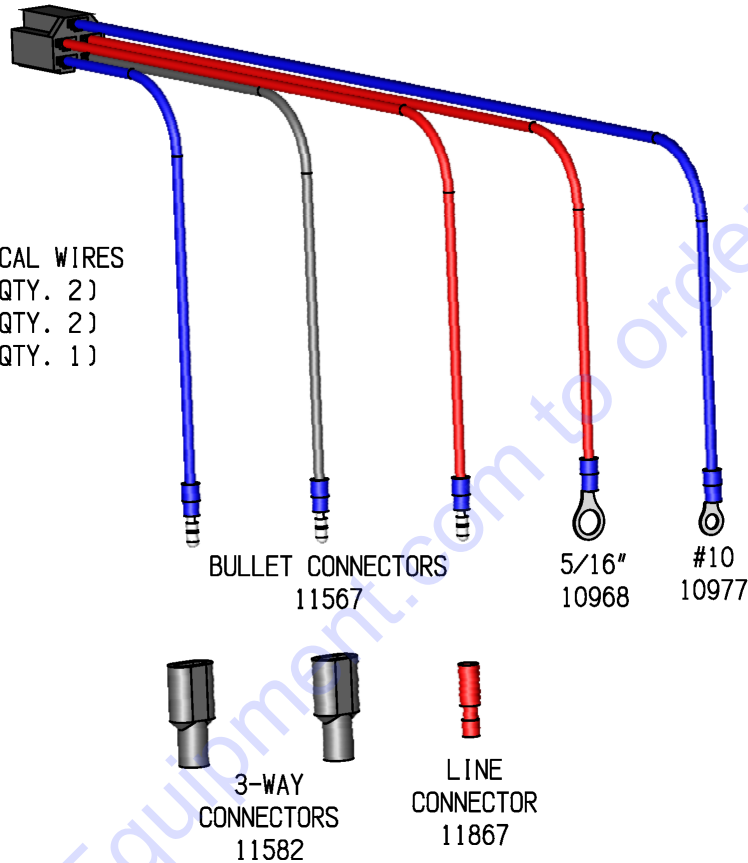

STRANDED ELECTRICAL WIRES
 9" 14GA. BLUE (QTY. 2)
 9" 14GA. RED (QTY. 2)
 9" 14GA. BLACK (QTY. 1)

PART #	DESCRIPTION	QTY.
10675	TERMINAL, FEM., KOHLER 25-452-01-S	5
10968	TERM., RING 5/16 16-14GA. INSULATED	1
10977	TERM., RING #10 12-10GA. INSULATED	1
11567	CONNECTOR, BULLET STD. 16-14GA.BLUE	3
11582	CONNECTOR, BULLET 3-WAY FEMALE	2
11867	CONNECTOR, LINE STD. 22-18GA.(RED)	1
51049	CONNECTOR, WIRE HARNESS, FEMALE	1

OTHER WIRES ASSEMBLIES

RED STARTER & BATTERY WIRES

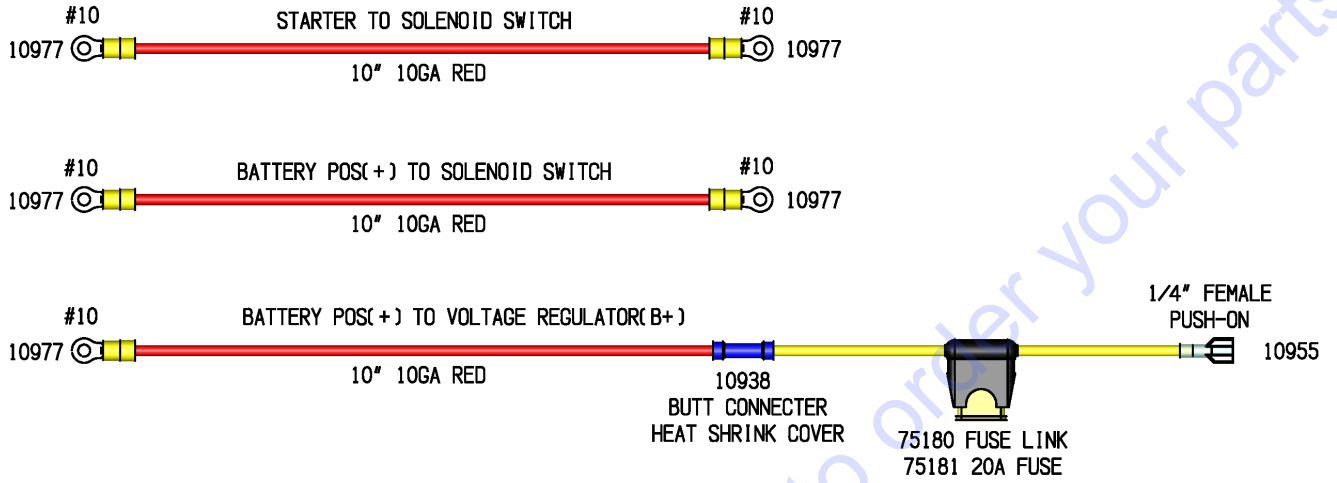

GROUND WIRES

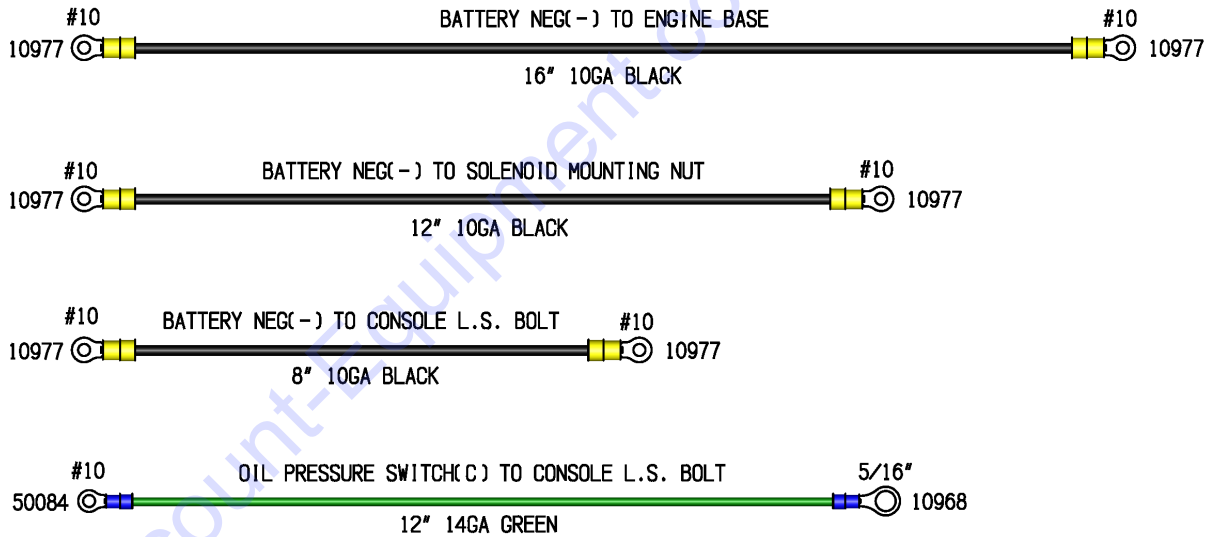

PART #	DESCRIPTION	QTY.
10938	CONNECTOR, BUTT 16-14GA. INSULATED	1
10955	TERM., FEM. PUSH-ON 1/4" 16-14GA.	1
10968	TERM., RING 5/16 16-14GA. INSULATED	1
10977	TERM., RING #10 12-10GA. INSULATED	11
50084	TERM., RING #10 16-14GA. INSULATED	1
75180	FUSEHOLDER, 1-30A, ATC BLADE	1
75181	FUSE, 20A, ATC BLADE	1

PARTS FINDER

**Search Website
by Part Number**



**Search Manual
Library For Parts
Manual & Lookup Part
Numbers – Purchase
or Request Quote**

Search Manuals

Enter your information to help us find the right parts manual for your machine.

* Brand:

* Model:

* Serial:

* Part Number:

SEARCH

**Can't Find Part or
Manual? Request Help
by Manufacturer,
Model & Description**

Parts Order Form

Please fill in the following information to help us find the right part for your machine.

Manufacturer:	<input type="text"/>
Model:	<input type="text"/>
Description:	<input type="text"/>
Part Number:	<input type="text"/>
Quantity:	<input type="text"/>
Notes:	<input type="text"/>

Submit

Discount-Equipment.com is your online resource for quality parts & equipment.

Florida: **561-964-4949** Outside Florida TOLL FREE: **877-690-3101**

Need parts?

Click on this link: <http://www.discount-equipment.com/category/5443-parts/> and choose one of the options to help get the right parts and equipment you are looking for. Please have the machine model and serial number available in order to help us get you the correct parts. If you don't find the part on the website or on one of the online manuals, please fill out the request form and one of our experienced staff members will get back to you with a quote for the right part that your machine needs.

We sell worldwide for the brands: Genie, Terex, JLG, MultiQuip, Mikasa, Essick, Whiteman, Mayco, Toro Stone, Diamond Products, Generac Magnum, Airman, Haulotte, Barreto, Power Blanket, Nifty Lift, Atlas Copco, Chicago Pneumatic, Allmand, Miller Curber, Skyjack, Lull, Skytrak, Tsurumi, Husquvarna Target, Stow, Wacker, Sakai, Mi-T-M, Sullair, Basic, Dynapac, MBW, Weber, Bartell, Bennar Newman, Haulotte, Ditch Runner, Menegotti, Morrison, Contec, Buddy, Crown, Edco, Wyco, Bomag, Laymor, EZ Trench, Bil-Jax, F.S. Curtis, Gehl Pavers, Heli, Honda, ICS/PowerGrit, IHI, Partner, Imer, Clipper, MMD, Koshin, Rice, CH&E, General Equipment, Amida, Coleman, NAC, Gradall, Square Shooter, Kent, Stanley, Tamco, Toku, Hatz, Kohler, Robin, Wisconsin, Northrock, Oztec, Toker TK, Rol-Air, APT, Wylie, Ingersoll Rand / Doosan, Innovatech, Con X, Ammann, Mecalac, Makinex, Smith Surface Prep, Small Line, Wanco, Yanmar