



PARTS LIST MANUAL

HEAVY-DUTY FLOOR GRINDER / POLISHER

ELECTRIC MODEL



MODEL 2DHDE-5B
SKU # 58100

**READ AND UNDERSTAND THE OPERATOR'S SAFETY MANUAL THOROUGHLY
BEFORE ATTEMPTING TO OPERATE THIS EQUIPMENT.**
Death or serious injury could occur if this machine is used improperly.



PARTS FINDER

**Search Website
by Part Number**



**Search Manual
Library For Parts
Manual & Lookup Part
Numbers – Purchase
or Request Quote**

Search Manuals

Enter your information to help us find the right parts manual for your machine.

* Brand:

* Model:

* Serial:

* Part Number:

SEARCH

**Can't Find Part or
Manual? Request Help
by Manufacturer,
Model & Description**

Parts Order Form

Please fill in the following information to help us find the right part for your machine.

Manufacturer:	<input type="text"/>
Model:	<input type="text"/>
Description:	<input type="text"/>
Part Number:	<input type="text"/>
Quantity:	<input type="text"/>
Notes:	<input type="text"/>

REQUEST HELP

Discount-Equipment.com is your online resource for quality parts & equipment.

Florida: **561-964-4949** Outside Florida TOLL FREE: **877-690-3101**

Need parts?

Click on this link: <http://www.discount-equipment.com/category/5443-parts/> and choose one of the options to help get the right parts and equipment you are looking for. Please have the machine model and serial number available in order to help us get you the correct parts. If you don't find the part on the website or on one of the online manuals, please fill out the request form and one of our experienced staff members will get back to you with a quote for the right part that your machine needs.

We sell worldwide for the brands: Genie, Terex, JLG, MultiQuip, Mikasa, Essick, Whiteman, Mayco, Toro Stone, Diamond Products, Generac Magnum, Airman, Haulotte, Barreto, Power Blanket, Nifty Lift, Atlas Copco, Chicago Pneumatic, Allmand, Miller Curber, Skyjack, Lull, Skytrak, Tsurumi, Husquvarna Target, Stow, Wacker, Sakai, Mi-T-M, Sullair, Basic, Dynapac, MBW, Weber, Bartell, Bennar Newman, Haulotte, Ditch Runner, Menegotti, Morrison, Contec, Buddy, Crown, Edco, Wyco, Bomag, Laymor, EZ Trench, Bil-Jax, F.S. Curtis, Gehl Pavers, Heli, Honda, ICS/PowerGrit, IHI, Partner, Imer, Clipper, MMD, Koshin, Rice, CH&E, General Equipment, Amida, Coleman, NAC, Gradall, Square Shooter, Kent, Stanley, Tamco, Toku, Hatz, Kohler, Robin, Wisconsin, Northrock, Oztec, Toker TK, Rol-Air, APT, Wylie, Ingersoll Rand / Doosan, Innovatech, Con X, Ammann, Mecalac, Makinex, Smith Surface Prep, Small Line, Wanco, Yanmar



SAFETY INFORMATION



SAFETY MESSAGES

• Safety Instructions are preceded by a graphic alert symbol of DANGER, WARNING, or CAUTION.

DANGER Indicates an imminent hazard which, if not avoided, will result in death or serious injury.

WARNING Indicates an imminent hazard which, if not avoided, can result in death or serious injury.

CAUTION Indicates hazards which, if not avoided, could result in serious injury and or damage to the equipment.

GASOLINE / PROPANE POWERED EQUIPMENT

WARNING • Engine exhaust from this product contains chemicals known to the State of California to cause cancer, birth defects or other reproductive harm.

WARNING • Tilting a gasoline powered machine fitted with an EPA approved vented charcoal filter gas cap, beyond 20° can cause fuel leakage. If a leak occurs, do not start or run the engine until the leak is fixed. Eliminate all other ignition sources in the immediate area (no smoking, flares, sparks or flames). Use approved gasoline absorbing material to contain the fuel leakage. Then use clean, non-sparking tools to collect absorbed materials then dispose of these contaminants properly.

 • Gasoline is extremely flammable and poisonous. It should only be dispensed in well ventilated areas, and with a cool engine.

• Small gasoline engines produce high concentrations of carbon monoxide (CO) example: a 5 HP 4 cycle engine operation in an enclosed 100,000 cu. ft. area with only one change of air per hour is capable of providing deadly concentrations of CO in less than fifteen minutes. Five changes of air in the same area will produce noxious fumes in less than 30 minutes. Gasoline powered equipment should not be used in enclosed or partially enclosed areas. Symptoms of CO poisoning include, head-ache, nausea, weakness, dizziness, visual problems and loss of consciousness. If symptoms occur - get into fresh air and seek medical attention immediately.

• Never refuel a hot engine or an engine while it is running.
• Engines are shipped from factory without fuel/oil.

 • Propane is extremely flammable and is heavier than air and tends to settle in low areas where a spark or flame could ignite gas. DO NOT start or operate this propane engine in a poorly ventilated area where leaking propane gas could accumulate and endanger safety of persons in area. If headache develops, shut off machine. Have it checked for carbon monoxide emissions by a qualified technician before using it again. To ensure personal safety, installation and repair of propane fuel supply systems must be performed only by qualified technicians. Carbon monoxide emissions from this machine are greatly increased due to a dirty combustion air cleaner.

ELECTRICAL POWERED EQUIPMENT

 Extreme care must be taken when operating electric models with water present: Ensure power cord is properly grounded, is attached to a Ground-Fault-Interrupter (GFI) outlet, and is undamaged.

- Check all electrical cables - be sure connections are tight and cable is continuous and in good condition. Be sure cable is correctly rated for both the operating current and voltage of this equipment.
- Improper connection of the equipment grounding conductor can result in a risk of electric shock. Check with qualified electrician or service person if there is any doubt as to whether the outlet is properly grounded. Adhere to all local codes and ordinances.
- NOTE: In the event of a malfunction or breakdown, grounding provides a path of least resistance for the electric current to dissipate. The motor is equipped with a grounded plug and must be connected to an outlet that is properly installed and properly grounded. DO NOT modify the plug provided on the motor. If the plug does not fit the outlet have a qualified electrician install the proper receptacle.

ELECTRICAL POWERED EQUIPMENT CONTINUED

- Do not disconnect power by pulling cord. To disconnect, grasp the plug, not the cord.
- Unplug power cord at the machine when not in use and before servicing.
- Switch motor OFF before disconnecting power.
- Never use frayed, damaged, taped or under rated extension cords. Electrical shock could result in death or serious injury to the operator and damage to the equipment.
- Assure you are using the proper extension cord length.

GENERAL INSTRUCTIONS

- Equipment should only be operated by trained personnel in good physical condition and mental health (not fatigued). The operator and maintenance personnel must be physically able to handle the bulk weight and power of this equipment.
- This is a one person tool. Maintain a safe operating distance to other personnel. It is the operators' responsibility to keep other people (workers, pedestrians, bystanders, etc.) away during operation. Block off the work area in all directions with roping, safety netting, etc. Failure to do so may result in others being injured by flying debris or exposing them to harmful dust and noise.
- This equipment is intended for commercial use only.
- For the operator's safety and the safety of others, always keep all guards in place during operation.
- Never let equipment run unattended.



- Personal Protection Equipment and proper safety attire must be worn when operating this machinery. The operator must wear approved safety equipment appropriate for the job such as hard hat and safety shoes when conditions require. Hearing protection **MUST** be used when operational noise levels of this equipment may exceed 85db. Eye protection **MUST** be worn at all times.



Keep body parts, loose clothing and accessories away from moving parts. Failure to do so could result in dismemberment or death.

- Do not modify the machine.
- Stop motor/engine when adjusting or servicing this equipment. Maintain a safe operating distance from flammable materials. Sparks from the cutting-action of this machine can ignite flammable materials or vapors.



DUST WARNING



Some dust created by power sanding, sawing, grinding, drilling, and other construction activities contains chemicals known to cause cancer, birth defects, or other reproductive harm. Materials being removed can be toxic or hazardous. A breathing respirator is required to help protect the operator. Some examples of these chemicals are:

- Lead from lead-based paints.
- Crystalline silica from bricks, concrete and other masonry products. Your risk of exposure to these chemicals varies depending on how often you do this type of work. To reduce your risk: work in a well ventilated area, use a dust control system, such as an industrial-style vacuum, and wear approved personal safety equipment, such as a dust/particle respirator designed to filter out microscopic particles.
- See more on the importance of dust prevention and silica warnings at: osha.gov/silica

PARTS LIST MANUAL

HEAVY-DUTY FLOOR GRINDER/POLISHER

ELECTRIC MODELS

TABLE OF CONTENTS

<u>Section</u>	<u>Page Number</u>
Safety Messages and General Instructions	2
How To Order Replacement Parts	3
Illustration 1: Main Grouping	4, 5
Illustration 2: Handle & Wheel Carriage Grouping	6, 7
Illustration 3: Skirt, Vacuum Port & Water Hook-Up Grouping	8, 9
Illustration 4: Disc Assembly	10
Illustration 5: Disc Arrangement	11
Illustration 6: Motor & Belt Drive Grouping for 5 HP 60 Hz Units	12, 13
Wiring Diagram for Rotary Cam Switch	14
Wiring Diagram for Single-Phase 60Hz Motor	15
Decal Sheet 1	16
Decal Sheet 2	17
Blank Page	18
California Proposition 65	19
Limited Equipment Warranty of Sale - Terms & Conditions	20 (Back Page)

ILLUSTRATION 1: MAIN GROUPING

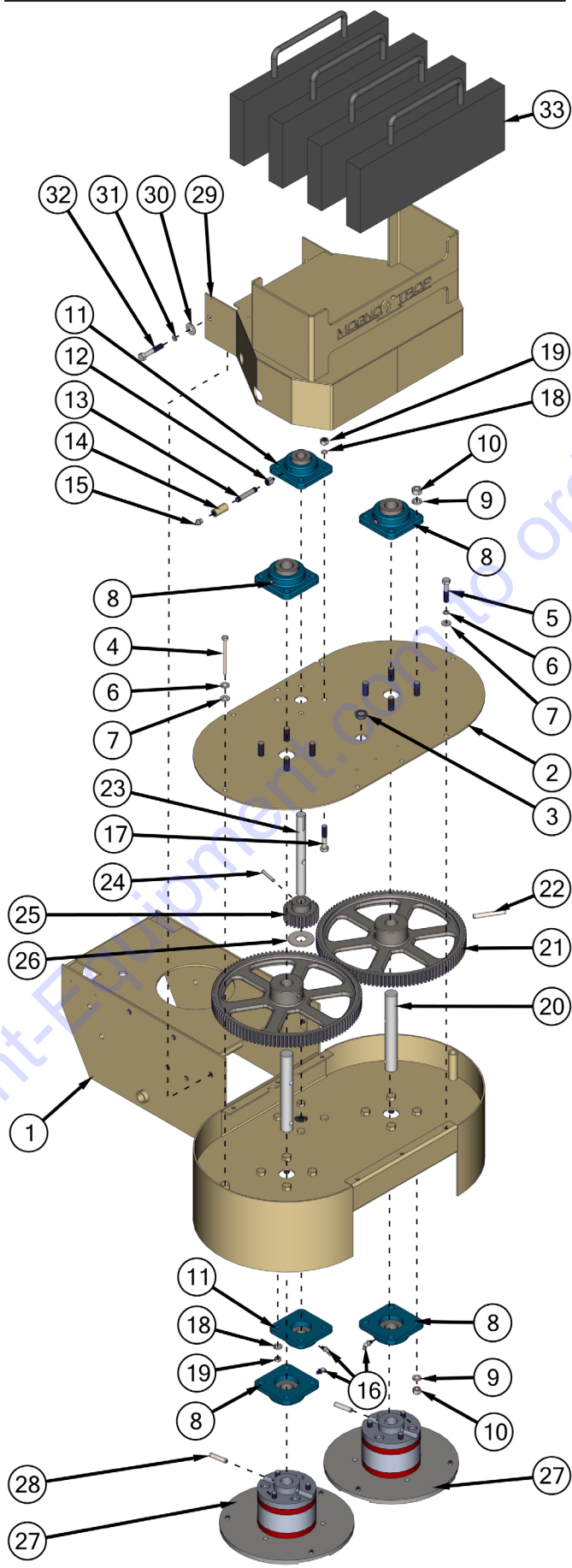

Go to Discount-Parts.com to order your parts

PARTS LISTING - ILLUSTRATION 1: MAIN GROUPING

ITEM #	PART #	DESCRIPTION	QTY.
1	77501	MAIN FRAME	1
2	77502	COVER, GEAR CASE (ELECTRIC)	1
3	10005	PLUG, HOLE 7/8" BRIGHT ZINC	1
4	10475	SCREW, CAP 1/4-20 X 3-1/4	2
5	10018	SCREW, CAP 1/4-20 X 3/4	6
6	10038	WASHER, LOCK 1/4 ZINC	8
7	10602	WASHER, FLAT 1/4 SAE ZINC	8
8	77008	BEARING, BALL 1" 4-HOLE FLANGE, ND	4
9	10450	WASHER, LOCK 7/16 ZINC	16
10	10481	NUT, HEX 7/16-20 ZINC	16
11	77009	BEARING, BALL 3/4" 4-HOLE FLANGE	2
12	50541	ADAPTER, GREASE FIT. 1/8PT X 1/4-28	1
13	10699	PIPE NIPPLE 1/8NPT X 2" (BLACK)	1
14	10585	PIPE COUPLING 1/8 NPT (BLACK STEEL)	1
15	10953	FITTING, GREASE 1/8 NPT STRAIGHT	1
16	10960	FITTING, GREASE 1/4-28 X 45°	3
17	10309	SCREW, CAP 3/8-24 X 1-1/4 ZINC	4
18	10811	WASHER, LOCK 3/8 ZINC	8
19	10014	NUT, HEX 3/8-24 ZINC	8
20	77346	SHAFT, LARGE GEAR 1"DIA X 7"L	2
21	77012	GEAR, SPUR 112 TOOTH (DRIVEN)	2
22	63056	PIN, H.D.COILED SPRING 3/8 X 2-1/2	2
23	77011	SHAFT, PINION GEAR 3/4DIA X 7-3/8"L	1
24	10037	PIN, ROLL 1/4 X 1-1/2	1
25	77053	GEAR, SPUR 25 TOOTH (PINION)	1
26	10009	WASHER, FLAT 3/4 SAE ZINC	1
27	77170	MT RETROFIT FOR CLASSIC GRINDER	2
28	10063	PIN, ROLL 3/8 X 2	2
29	77505	HOOD, ELEC. MODEL	1
30	10025	WASHER, FLAT 3/8 SAE ZINC	2
31	10811	WASHER, LOCK 3/8 ZINC	2
32	10907	SCREW, CAP 3/8-16 X 3/4	2
33	77506	WEIGHT BLOCK, 40 LB.	4

ILLUSTRATION 2: HANDLE & WHEEL CARRIAGE GROUPING

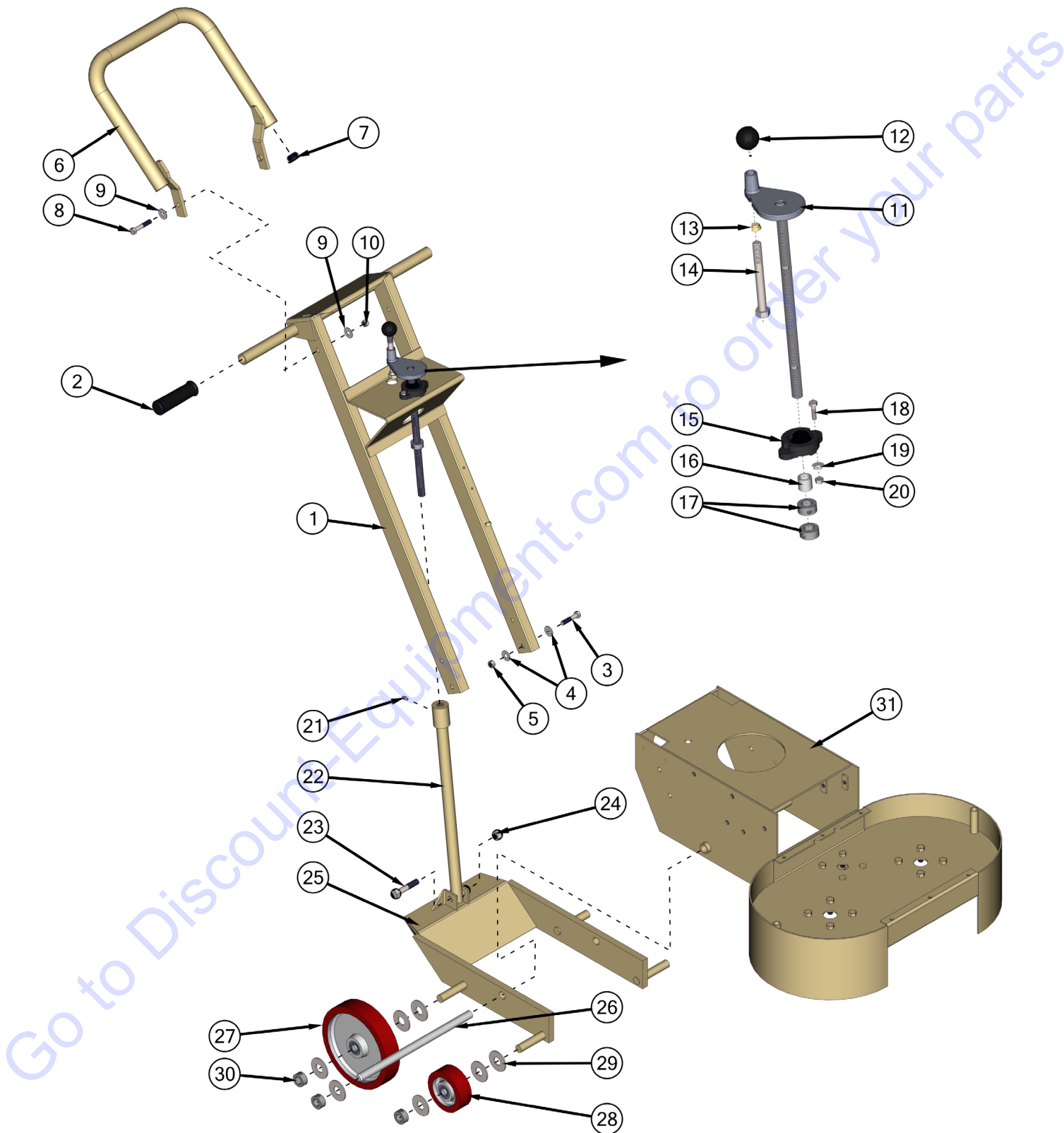

PARTS LISTING - ILLUSTRATION 2: HANDLE & WHEEL CARRIAGE GROUPING			
ITEM #	PART #	DESCRIPTION	QTY.
1	77507	HANDLE BAR, ELEC. MODEL	1
2	10608	GRIP, HAND 1" MODEL AT	2
3	10029	SCREW, CAP 3/8-24 X 1-3/4	4
4	10025	WASHER, FLAT 3/8 SAE ZINC	8
5	10004	NUT, HEX LOCK 3/8-24 ZINC	4
6	77508	HANDLE EXTENSION	1
7	77528	PLUG, BLACK 1"RD. TUBING 10-14 GA.	2
8	10030	SCREW, CAP 3/8-24 X 2	2
9	10025	WASHER, FLAT 3/8 SAE ZINC	4
10	10004	NUT, HEX LOCK 3/8-24 ZINC	2
11	65019	HANDWHEEL, SMALL W/ 5/8-8 X 13"ROD	1
12	14023	KNOB, BALL 1-3/8 W/ 1/2-13THD, BLK.	1
13	50550	SLEEVE, BRASS 1/2" TAPERED	1
14	10346	SCREW, SKT. HD. CAP 1/2-13 X 4-1/2	1
15	80009	BEARING, BALL 5/8" 2-HOLE (NO G.F.)	1
16	55010	SPACER, HANDWHEEL 5/8"ID X 3/4"L	1
17	10096	COLLAR, LOCKING 5/8"ID	2
18	10412	BOLT, CARRIAGE 1/4-20 X 1	2
19	10602	WASHER, FLAT 1/4 SAE ZINC	2
20	10861	NUT, KEPS LOCK 1/4-20 ZINC	2
21	10808	FITTING, GREASE 1/4-28 STRAIGHT	1
22	77511	LINKAGE, LOWER, ELEC.MODEL 20"LOA	1
23	10343	SCREW, CAP 1/2-20 X 2-1/2	1
24	10154	NUT, HEX NYLON LOCK 1/2-20 ZINC	1
25	77510	CARRIAGE, WHEEL	1
26	77537	FORK SHAFT 3/4"DIA. X 13-3/4"L	1
27	68008	WHEEL 8 X 1-5/8 X 3/4"BRG., POLY	2
28	77520	WHEEL 4 X 1-1/2 X 3/4"BRG., POLY	2
29	10009	WASHER, FLAT 3/4 SAE ZINC	14
30	10428	COLLAR, LOCKING 3/4"ID	6
31	77501	MAIN FRAME (REFER TO ILLUS. 1)	1

ILLUSTRATION 3: SKIRT, VACUUM PORT & WATER HOOK-UP GROUPING

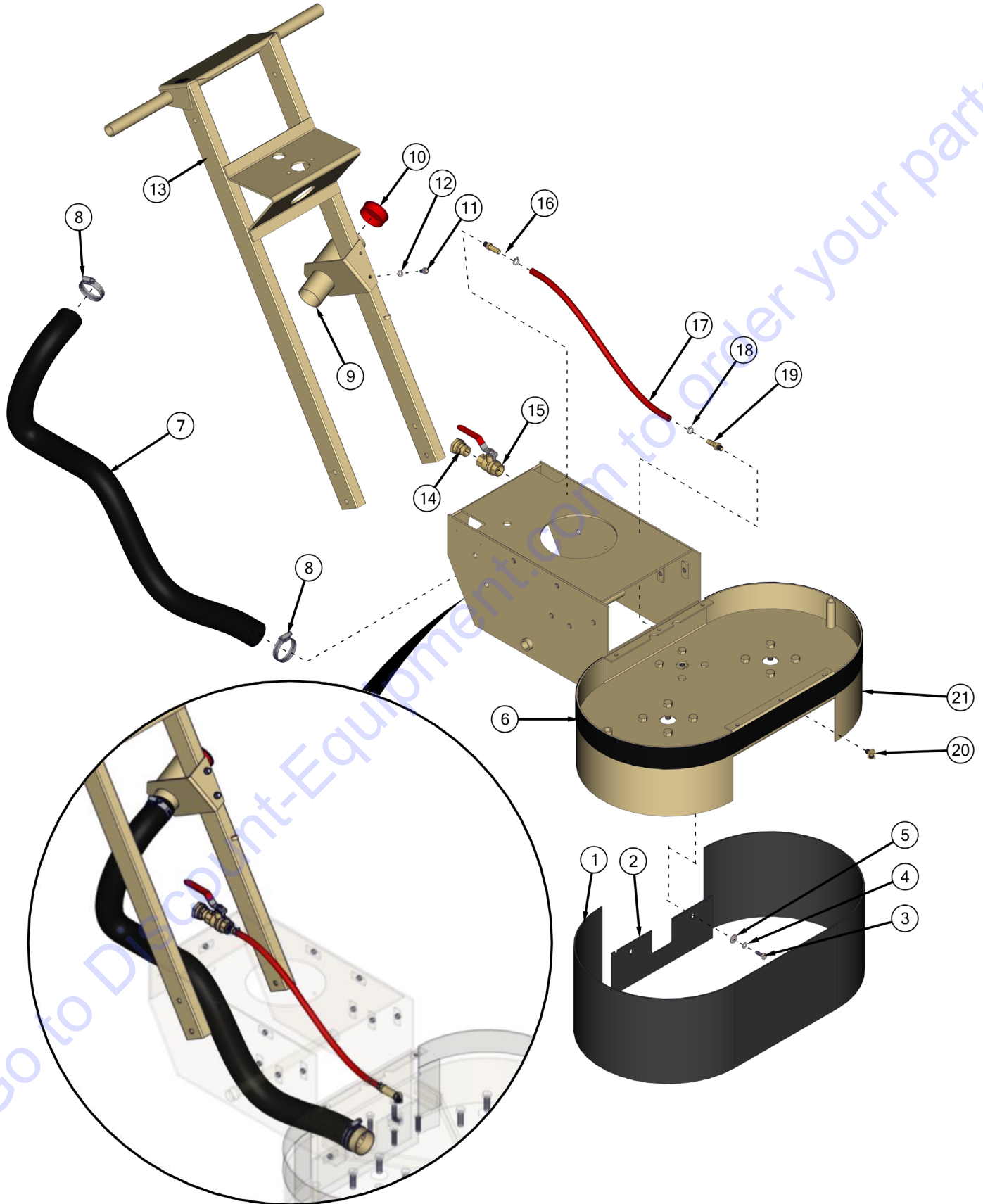

PARTS LISTING - ILLUSTRATION 3: SKIRT, VACUUM PORT & WATER HOOK-UP GROUPING			
ITEM #	PART #	DESCRIPTION	QTY.
1	77529	RUBBER SKIRT 1/8 X 8 X 58 W/VEL	1
2	77504	RUBBER SKIRT, REAR 1/8 X 4 X 11	1
3	10018	SCREW, CAP 1/4-20 X 3/4	2
4	10038	WASHER, LOCK 1/4 ZINC	2
5	10602	WASHER, FLAT 1/4 SAE ZINC	2
6	86357	VELCRO-HOOK, 2" WIDE, WATER RESISTANT 1 PIECE CUT 57-1/4"L & 2 PIECES CUT 5-1/4"L	6 FT. TOTAL
7	77551	HOSE, FLEX 2"ID X 36"L	1
8	10766	CLAMP, HOSE, SAE #32, ADJ. TO 2-1/2	2
9	86347	BRACKET, MULTI-VAC PORT 2-3"	1
10	65021	CAP/PLUG 2" RED PLASTIC, FLANGED	1
11	10846	SCREW, CAP STSHW 1/4-20 X 1/2	2
12	10038	WASHER, LOCK 1/4 ZINC	2
13	77507	HANDLE BAR, ELEC. MODEL (REFER TO ILLUS. 2)	1
14	80021	CONN., SWIVEL FEM. 3/4HOSE X 1/2MPT	1
15	10711	VALVE, BALL 1/2 FPT	1
16	50075	BARB, 3/8 HOSE X 1/4MPT (BRASS)	1
17	77521	HOSE 3/8"ID X 18"L	1
18	50069	CLAMP, HOSE, SAE #6, ADJ. TO 13/16	2
19	10694	BARB, 3/8HOSE X 1/8MPT	1
20	10772	ELBOW, STREET 1/8NPT X 45 (BRASS)	1
21	77501	MAIN FRAME (REFER TO ILLUS. 1)	1

ILLUSTRATION 4: COMPLETE MAGNA-TRAP GRINDING HEAD

STANDARD

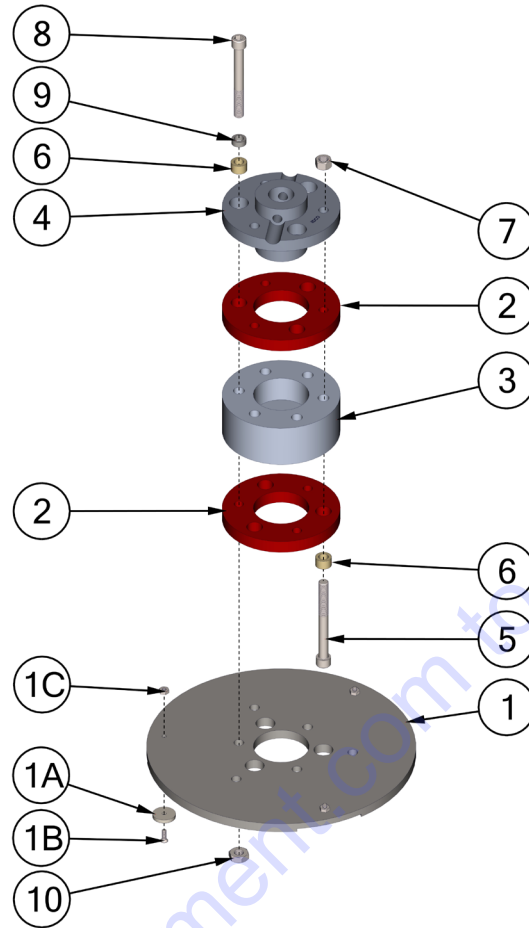

ITEM #	PART #	DESCRIPTION	QTY.*
1-10	77170	MT RETROFIT FOR CLASSIC GRINDER	1
1	86391	10" MAGNA-TRAP DISC W/ MAGNETS	1
1A	36064	MAGNET, NEODYMIUM RING 7/8 X 1/8	3
1B	10647	SCREW, FLAT HD PHILLIPS 8/32 X 1/2	3
1C	10642	NUT, KEPS LOCK 8-32 ZINC	3
2	10112	RING, RUBBER, 4-1/2"OD X 1/2"THK	2
3	77173	HUB SPACER, MAGNA-TRAP DISC	1
4	77010	HUB, ALUMINIUM 6-HOLE (GRINDER)	1
5	11856	SCREW, SKT. HD. CAP 3/8-24 X 3-1/2	3
6	10011	SPACER, STEEL 5/8OD X 3/8ID X3/8T	6
7	10058	NUT, HEX LOCK 3/8-24 W/ NYLON PATCH	3
8	11855	SCREW, SKT. HD. CAP 3/8-24 X 3-1/4	3
9	10113	SPACER, STEEL 9/16 X 3/8ID X 7/32T	3
10	11725	NUT, HEX JAM 3/8-24 ZINC (USE RED LOCTITE)	3

*NOTE: QUANTITIES ARE BASED ON 1 DISC. 2 DISC ARE REQUIRED.

ILLUSTRATION 5: COMPLETE MAGNA-TRAP POLISHING HEAD

OPTIONAL

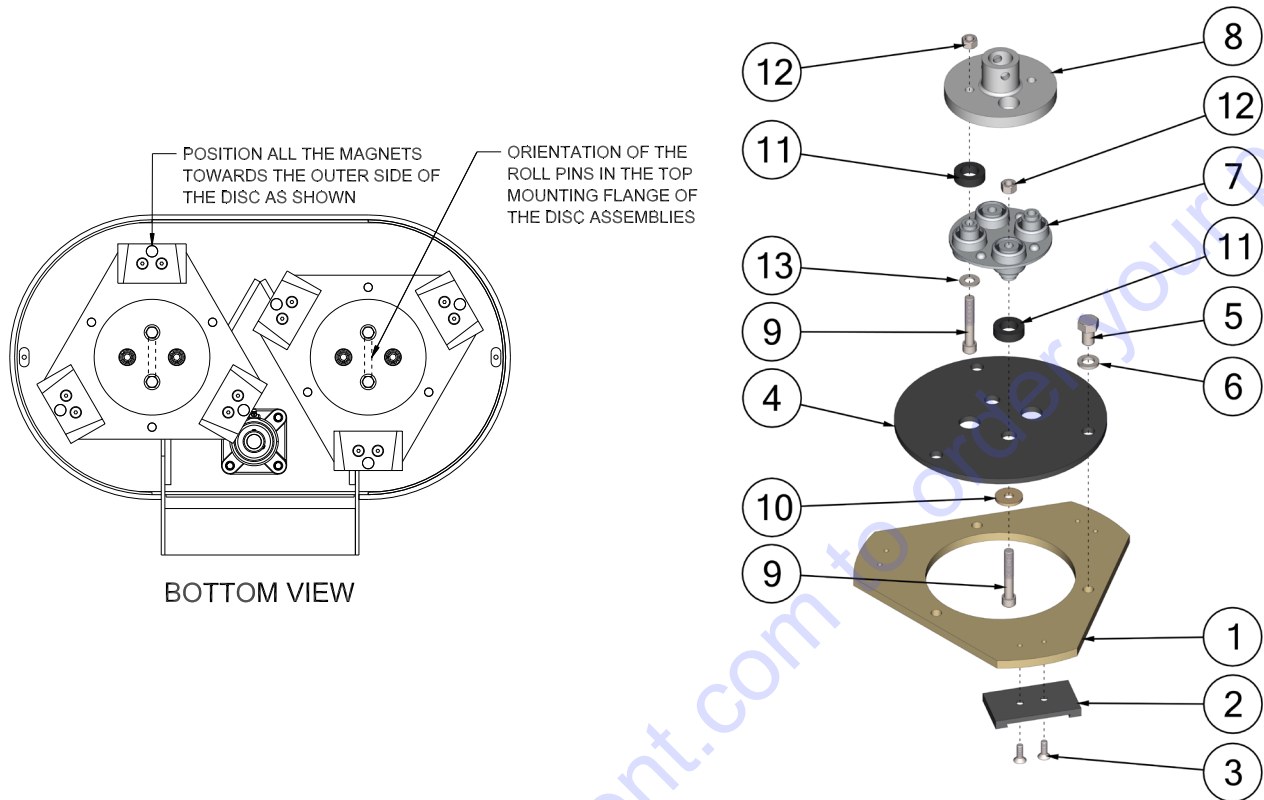

ITEM #	PART #	DESCRIPTION	QTY.*
1-13	77535	DISC ASSY. COMPLETE, 2DHDE/P & 2DP	1
1	75175	DISC, QUICK-CHANGE	1
2	QC-HOLDER-EDCO	HOLDER, MAGNETIC QUICK CHANGE	3
3	10147	SCREW, FLAT HD SKT 1/4-20 X 3/4	6
4	L18567	DISC TOP PLATE	1
5	11614	SCREW, CAP 1/2-20 X 3/4	3
6	10045	WASHER, LOCK 1/2 ZINC	3
7	86017	COUPLING, MORFLEX 402 CENTER	1
8	77518	FLANGE, MORFLEX COUPLING	1
9	10114	SCREW, SKT. HD. CAP 3/8-24 X 2-1/4	4
10	11695	WASHER, 1.1210 X .3750 X .1280	2
11	86343	BUSHING, RUBBER 1-1/4 X 3/4 X 3/8	4
12	10004	NUT, HEX LOCK 3/8-24 ZINC	4
13	10025	WASHER, FLAT 3/8 SAE ZINC	4

*NOTE: QUANTITIES ARE BASED ON 1 DISC. 2 DISC ARE REQUIRED.

PARTS LISTING - ILLUSTRATION 6: MOTOR GROUPING FOR 5 HP 60 Hz UNITS			
ITEM #	PART #	DESCRIPTION	QTY.
1	16043	MOTOR, BALDOR 5HP 1PH 60HZ 1725RPM	1
	16507	REPLACEMENT PARTS: CAPACITOR, RUN, BALDOR OC3030F11 30MFD 370V	1
	16508	CAPACITOR, START, BALDOR EC1216C06 216-259 MFD, 250V	2
	16509	RESET BUTTON, BALDOR TPLED1027	1
2	77512	MOUNT, MOTOR	1
3	10021	SCREW, CAP 3/8-24 X 1	4
4	10025	WASHER, FLAT 3/8 SAE ZINC	4
5	10811	WASHER, LOCK 3/8 ZINC	4
6	10014	NUT, HEX 3/8-24 ZINC	4
7	10055	SCREW, CAP 3/8-16 X 1	4
8	10811	WASHER, LOCK 3/8 ZINC	4
9	10025	WASHER, FLAT 3/8 SAE ZINC	4
10	10790	CONDUIT LOCK NUT 1/2 NP (LOC. INSIDE BOX)	1
11	41130	STRAIN RELIEF 1/2NPT X .550-.650"	1
12	77522	WIRE HARNESS 10/3 X 44"L (MOTOR CORD)	1
13	77523	WIRE HARNESS 10/3 X 53"L (POWER CORD)	1
14	40066	STRAIN RELIEF 1/2NPT X .350-.450"	2
15	77043-1	SWITCH ADAPTER, PG16 TO 1/2"NPT	2
16	77043	SWITCH, ROTARY CAM ON/OFF	1
17	77042	BRACKET, ROTARY CAM SWITCH	1
18	11663	SCREW, MACHINE 8-32 X 1/2 RHCD ZINC (LOCATED INSIDE SWITCH BOX)	4
19	10462	NUT, KEPS LOCK 8-32 ZINC	4
20	10846	SCREW, CAP STSHW 1/4-20 X 1/2	2
21	10038	WASHER, LOCK 1/4 ZINC	2
22	56322	CONNECTOR, LOCKING 30A/250V L6-30C	1
23	56323	PLUG, LOCKING 30A/250V L6-30P	1
24	77509	HANGER, POWER CORD	1
25	10982	TIE, CABLE, BLACK NYLON 11-1/4"	4
26	10846	SCREW, CAP STSHW 1/4-20 X 1/2	1
27	10038	WASHER, LOCK 1/4 ZINC	1
28	11565	CLAMP, LOOM, 5/8" (SAE SIZE 10)	1
29	15204	PLUG, RECT. HOLE, PLASTIC SNAP-IN	1
30	77341	SHEAVE 5"OD X 2GR.B X 1-1/8"BORE	1
31	10115	KEY 1/4SQ X 2	1
32	77058	SHEAVE 5"OD X 2GR.B X 3/4"BORE	1
33	10016	KEY 3/16SQ X 1-1/2	1
34	10251	BELT B-34	2

WIRING DIAGRAM FOR ROTARY CAM SWITCH

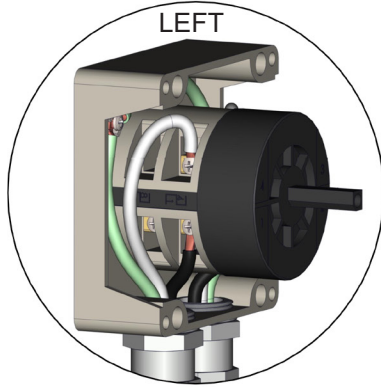
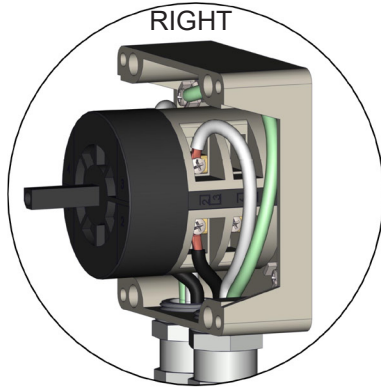

#77043
ROTARY CAM SWITCH
32AMP 60° ROTARY CAM
LOVATO 7GN3210P25

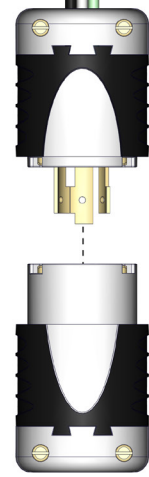
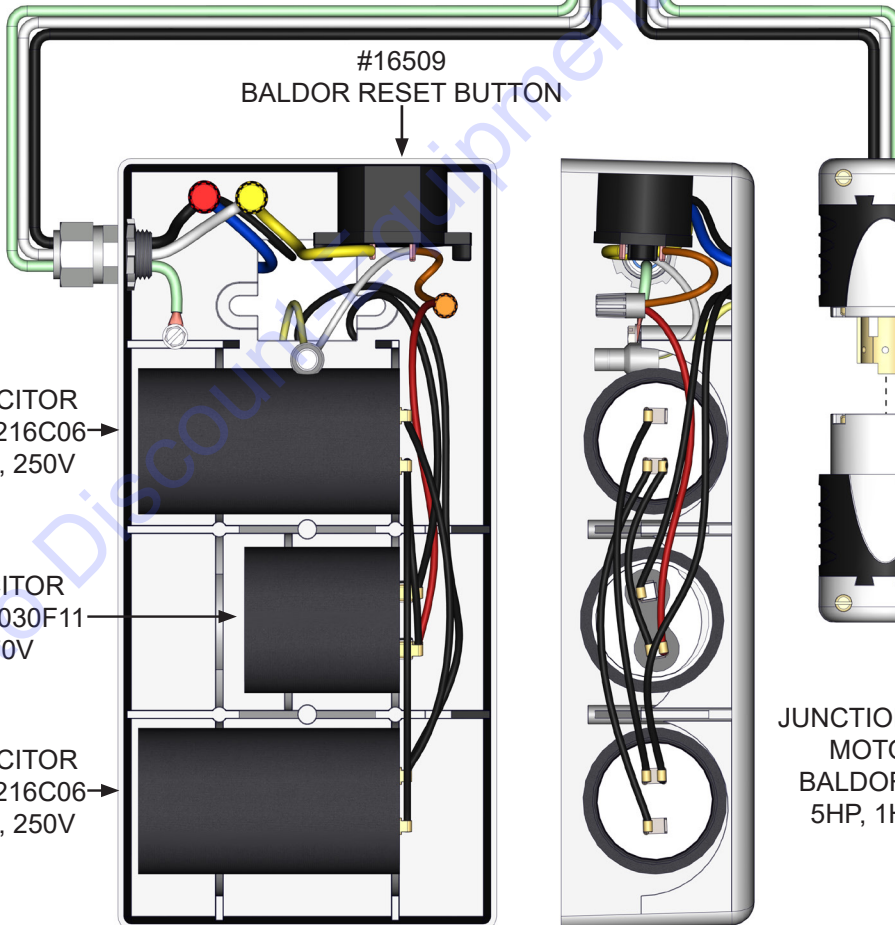
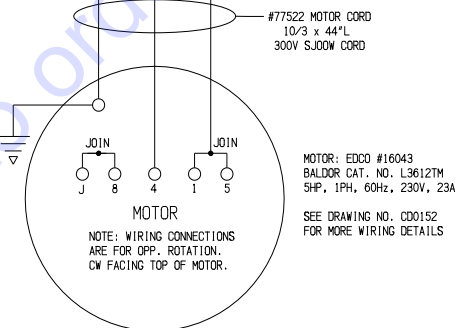
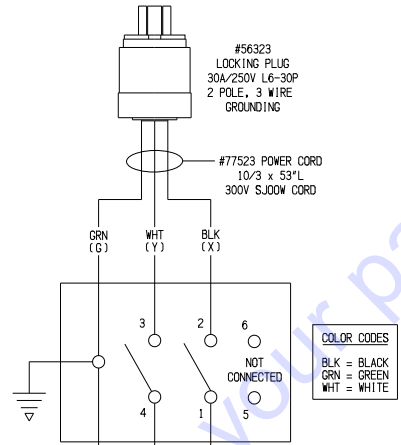
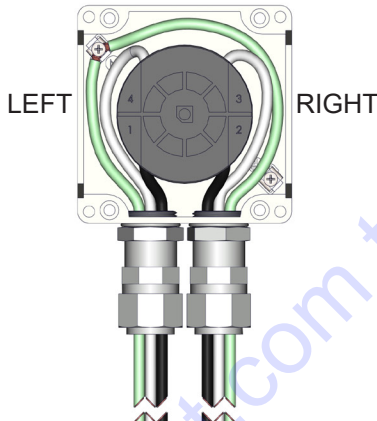

JUNCTION BOX DETAIL FROM:
MOTOR: EDCO #16043
BALDOR CAT. NO. L3612TM
5HP, 1HP, 60Hz, 230V, 23A

WIRING DIAGRAM FOR SINGLE-PHASE 60Hz MOTOR

BALDOR CAT. NO. L3612TM

CD0152

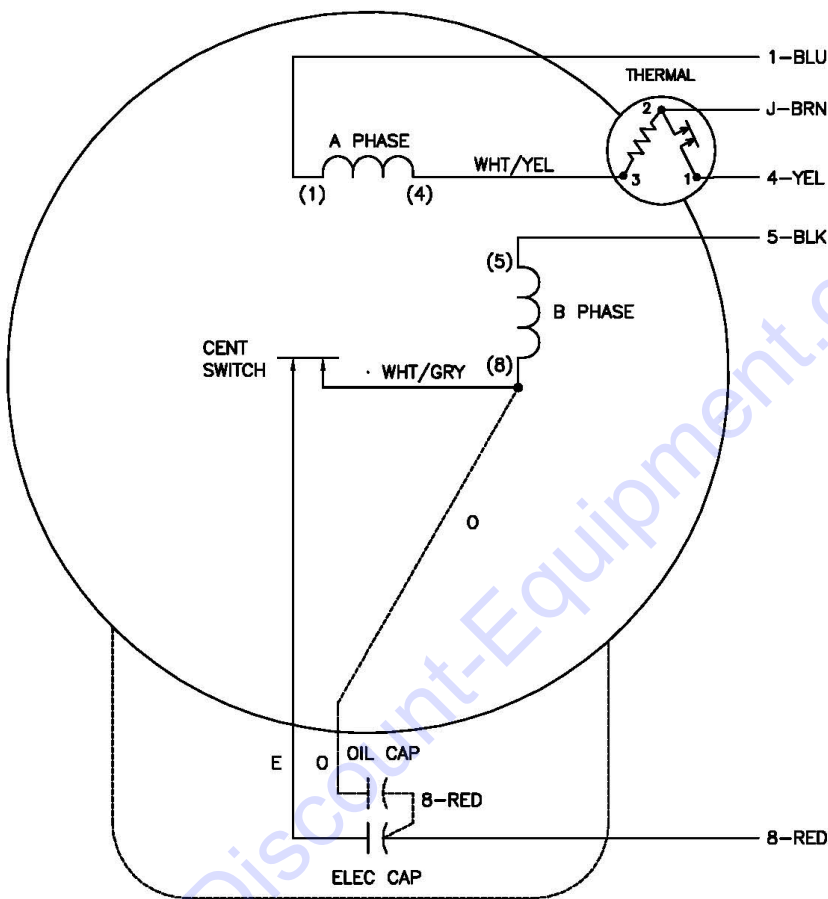

	LINE A	LINE B	JOIN
STD	1,8	4	J,5
OPP	1,5	4	J,8

NOTES:

1. STANDARD ROTATION IS CCW FACING END OPPOSITE SHAFT EXTENSION.
2. MULTIPLE CAPACITORS ARE CONNECTED IN PARALLEL UNLESS OTHERWISE SPECIFIED.
3. OPTIONAL OIL CAPACITOR IS PROVIDED WHEN SPECIFIED.
4. CAPACITORS MAY BE SEPERATELY MOUNTED.
5. LEAD COLORS ARE OPTIONAL. LEADS MUST ALWAYS BE NUMBERED AS SHOWN.

EV. DESC: REMOVE OPTIONAL THERMAL CONNECTION			BALDOR ELECTRIC Co.
EV. LTR: D	VERSION: 01	TDR: 000000373039	
ZS1000	FILE: \AAA\00026\903	REVISED: 11: 23: 45 08/11/2005	TYPE L OR LC, SV, REV, 5 LDS, THERM, CAPS MAY BE SEP MTD
CD0152	MTL: -	BY: ENJOEPO	



EDCO
EQUIPMENT DEVELOPMENT CO., INC.



WARNING: California Proposition 65

Proposition 65 applies to any company operating in California, selling products in California, or manufacturing products that may be sold in or brought into California. The purpose of Proposition 65 is to inform the public about exposure to these chemicals. EDCO has not shifted manufacturing processes, this is strictly an updated warning procedure required by the state of California. While the exposure from EDCO products may be negligible or well within the “no significant risk” range, out of an abundance of caution, EDCO has elected to provide these Proposition 65 warnings.

Depending on machine/part model the following warnings may apply:



WARNING: Cancer and Reproductive Harm -
For more information go to: www.P65Warnings.ca.gov



WARNING: Batteries, battery posts, terminals and related accessories can expose you to chemicals including lead and lead compounds, and other chemicals known to the State of California to cause cancer and birth defects or other reproductive harm. WASH HANDS AFTER HANDLING. For more information go to www.P65Warnings.ca.gov



WARNING: This product can expose you to chemicals including soots, tars, and mineral oils, which are known to the State of California to cause cancer, and carbon monoxide, which is known to the State of California to cause birth defects or other reproductive harm. For more information go to www.P65Warnings.ca.gov



WARNING: This machine used in its application on concrete/cement/brick surfaces can expose you to chemicals including crystalline silica which is known to the State of California to cause cancer. For more information go to www.P65Warnings.ca.gov

PARTS FINDER

**Search Website
by Part Number**



**Search Manual
Library For Parts
Manual & Lookup Part
Numbers – Purchase
or Request Quote**

Search Manuals

Enter your information to help us find the right parts manual for your machine.

* Brand:

* Model:

* Serial:

* Part Number:

SEARCH

**Can't Find Part or
Manual? Request Help
by Manufacturer,
Model & Description**

Parts Order Form

Please fill in the following information to help us find the right part for your machine.

Manufacturer:	<input type="text"/>
Model:	<input type="text"/>
Description:	<input type="text"/>
Part Number:	<input type="text"/>
Quantity:	<input type="text"/>
Notes:	<input type="text"/>

Submit

Discount-Equipment.com is your online resource for quality parts & equipment.

Florida: **561-964-4949** Outside Florida TOLL FREE: **877-690-3101**

Need parts?

Click on this link: <http://www.discount-equipment.com/category/5443-parts/> and choose one of the options to help get the right parts and equipment you are looking for. Please have the machine model and serial number available in order to help us get you the correct parts. If you don't find the part on the website or on one of the online manuals, please fill out the request form and one of our experienced staff members will get back to you with a quote for the right part that your machine needs.

We sell worldwide for the brands: Genie, Terex, JLG, MultiQuip, Mikasa, Essick, Whiteman, Mayco, Toro Stone, Diamond Products, Generac Magnum, Airman, Haulotte, Barreto, Power Blanket, Nifty Lift, Atlas Copco, Chicago Pneumatic, Allmand, Miller Curber, Skyjack, Lull, Skytrak, Tsurumi, Husquvarna Target, Stow, Wacker, Sakai, Mi-T-M, Sullair, Basic, Dynapac, MBW, Weber, Bartell, Bennar Newman, Haulotte, Ditch Runner, Menegotti, Morrison, Contec, Buddy, Crown, Edco, Wyco, Bomag, Laymor, EZ Trench, Bil-Jax, F.S. Curtis, Gehl Pavers, Heli, Honda, ICS/PowerGrit, IHI, Partner, Imer, Clipper, MMD, Koshin, Rice, CH&E, General Equipment, Amida, Coleman, NAC, Gradall, Square Shooter, Kent, Stanley, Tamco, Toku, Hatz, Kohler, Robin, Wisconsin, Northrock, Oztec, Toker TK, Rol-Air, APT, Wylie, Ingersoll Rand / Doosan, Innovatech, Con X, Ammann, Mecalac, Makinex, Smith Surface Prep, Small Line, Wanco, Yanmar