



REVISED STARTING
SERIAL #141010196

PARTS LIST MANUAL
MODEL SECNG-1.5L



NEW SINGLE-DISC CONCRETE FLOOR GRINDER

SKU #	MODEL #	POWER OPTION
59800	SECNG-1.5L	LEESON ELECTRIC MOTOR 1.5HP 60Hz 1-PHASE 115/230V



A Division of Equipment Development Company, Inc.

PARTS FINDER

**Search Website
by Part Number**



**Search Manual
Library For Parts
Manual & Lookup Part
Numbers – Purchase
or Request Quote**

Search Manuals

Enter your information to help us find the right part for your machine.

* Brand:

* Model:

* Serial:

* Part Number:

SEARCH

**Can't Find Part or
Manual? Request Help
by Manufacturer,
Model & Description**

Parts Order Form

Please fill in the following information to help us find the right part for your machine.

Manufacturer:	<input type="text"/>
Model:	<input type="text"/>
Description:	<input type="text"/>
Part Number:	<input type="text"/>
Quantity:	<input type="text"/>
Notes:	<input type="text"/>

SEARCH

Discount-Equipment.com is your online resource for quality parts & equipment.

Florida: **561-964-4949** Outside Florida TOLL FREE: **877-690-3101**

Need parts?

Click on this link: <http://www.discount-equipment.com/category/5443-parts/> and choose one of the options to help get the right parts and equipment you are looking for. Please have the machine model and serial number available in order to help us get you the correct parts. If you don't find the part on the website or on one of the online manuals, please fill out the request form and one of our experienced staff members will get back to you with a quote for the right part that your machine needs.

We sell worldwide for the brands: Genie, Terex, JLG, MultiQuip, Mikasa, Essick, Whiteman, Mayco, Toro Stone, Diamond Products, Generac Magnum, Airman, Haulotte, Barreto, Power Blanket, Nifty Lift, Atlas Copco, Chicago Pneumatic, Allmand, Miller Curber, Skyjack, Lull, Skytrak, Tsurumi, Husquvarna Target, Stow, Wacker, Sakai, Mi-T-M, Sullair, Basic, Dynapac, MBW, Weber, Bartell, Bennar Newman, Haulotte, Ditch Runner, Menegotti, Morrison, Contec, Buddy, Crown, Edco, Wyco, Bomag, Laymor, EZ Trench, Bil-Jax, F.S. Curtis, Gehl Pavers, Heli, Honda, ICS/PowerGrit, IHI, Partner, Imer, Clipper, MMD, Koshin, Rice, CH&E, General Equipment, Amida, Coleman, NAC, Gradall, Square Shooter, Kent, Stanley, Tamco, Toku, Hatz, Kohler, Robin, Wisconsin, Northrock, Oztec, Toker TK, Rol-Air, APT, Wylie, Ingersoll Rand / Doosan, Innovatech, Con X, Ammann, Mecalac, Makinex, Smith Surface Prep, Small Line, Wanco, Yanmar

READ AND UNDERSTAND THE OPERATORS INSTRUCTION MANUAL *THOROUGHLY* BEFORE ATTEMPTING TO OPERATE THIS EQUIPMENT.



Death or serious injury could occur if this machine is used improperly.



SAFETY MESSAGES

- Safety Instructions are preceded by a graphic alert symbol of DANGER, WARNING, or CAUTION.



Indicates an imminent hazard which, if not avoided, will result in death or serious injury.



Indicates an imminent hazard which, if not avoided, can result in death or serious injury.



Indicates hazards which, if not avoided, could result in serious injury and or damage to the equipment.

GASOLINE/PROPANE POWERED EQUIPMENT



- Engine exhaust from this product contains chemicals known to the State of California to cause cancer, birth defects or other reproductive harm.



- Gasoline is extremely flammable and poisonous. It should only be dispensed in well ventilated areas, and with a cool engine.

- Small gasoline engines produce high concentrations of carbon monoxide (CO) example: a 5 HP 4 cycle engine operation in an enclosed 100,000 cu. ft. area with only one change of air per hour is capable of providing deadly concentrations of CO in less than fifteen minutes. Five changes of air in the same area will produce noxious fumes in less than 30 minutes. Gasoline or propane powered equipment should not be used in enclosed or partially enclosed areas. Symptoms of CO poisoning include, headache, nausea, weakness, dizziness, visual problems and loss of consciousness. If symptoms occur - get into fresh air and seek medical attention immediately.

ELECTRICAL POWERED EQUIPMENT



Extreme care must be taken when operating electric models with water present: Ensure power cord is properly grounded, is attached to a Ground-Fault-Interrupter (GFI) outlet, and is undamaged.

- Check all electrical cables - be sure connections are tight and cable is continuous and in good condition. Be sure cable is correctly rated for both the operating current and voltage of this equipment.
- Improper connection of the equipment-grounding conductor can result in a risk of electric shock. Check with qualified electrician or service person if there is any doubt as to whether the outlet is properly grounded. Adhere to all local codes and ordinances.
- **NOTE:** In the event of a malfunction or breakdown, grounding provides a path of least resistance for the electric current to dissipate. The motor is equipped with a grounded plug and must be connected to an outlet that is properly installed and properly grounded. DO NOT modify the plug provided on the motor. If the plug does not fit the outlet have a qualified electrician install the proper receptacle.
- Switch motor OFF **before** disconnecting power.

- Do not disconnect power by pulling cord. To disconnect, grasp the plug, not the cord.
- Unplug power cord at the machine when not in use and before servicing.

GENERAL INSTRUCTIONS

- Equipment should only be operated by trained personnel in good physical condition and mental health (not fatigued). The operator and maintenance personnel must be physically able to handle the bulk weight and power of this equipment.
- This is a one person tool. Maintain a safe operating distance to other personnel. It is the **operators' responsibility** to keep other people (workers, pedestrians, bystanders, etc.) away during operation. Block off the work area in all directions with roping, safety netting, etc. for a safe distance. Failure to do so may result in others being injured by flying debris or exposing them to harmful dust and noise.
- This equipment is intended for commercial use only.
- For the operator's safety and the safety of others, always keep all guards in place during operation.
- Never let equipment run unattended.



- Personal Protection Equipment and proper safety attire must be worn when operating this machinery. The operator must wear approved safety equipment appropriate for the job such as hard hat and safety shoes when conditions require. Hearing protection MUST be used (operational noise levels of this equipment may exceed 85db). Eye protection MUST be worn at all times.



Keep body parts and loose clothing away from moving parts. Failure to do so could result in dismemberment or death.

- Do not modify the machine.
- Stop motor/engine when adjusting or servicing this equipment.



Maintain a safe operating distance from flammable materials. Sparks from the cutting-action of this machine can ignite flammable materials or vapors.

DUST WARNING



Some dust created by power sanding, sawing, grinding, drilling, and other construction activities contains chemicals known to cause cancer, birth defects, or other reproductive harm. Some examples of these chemicals are:

- Lead from lead-based paints, and
- Crystalline silica from bricks and concrete and other masonry products.

Your risk of exposure to these chemicals varies depending on how often you do this type of work. To reduce your risk: work in a well ventilated area, use a dust control system, such as an industrial-style vacuum, and wear approved personal safety equipment, such as a dust/particle respirator designed to filter out microscopic particles.

PARTS LIST MANUAL

MODEL SECNG-1.5L

NEW SINGLE-DISC CONCRETE FLOOR GRINDER

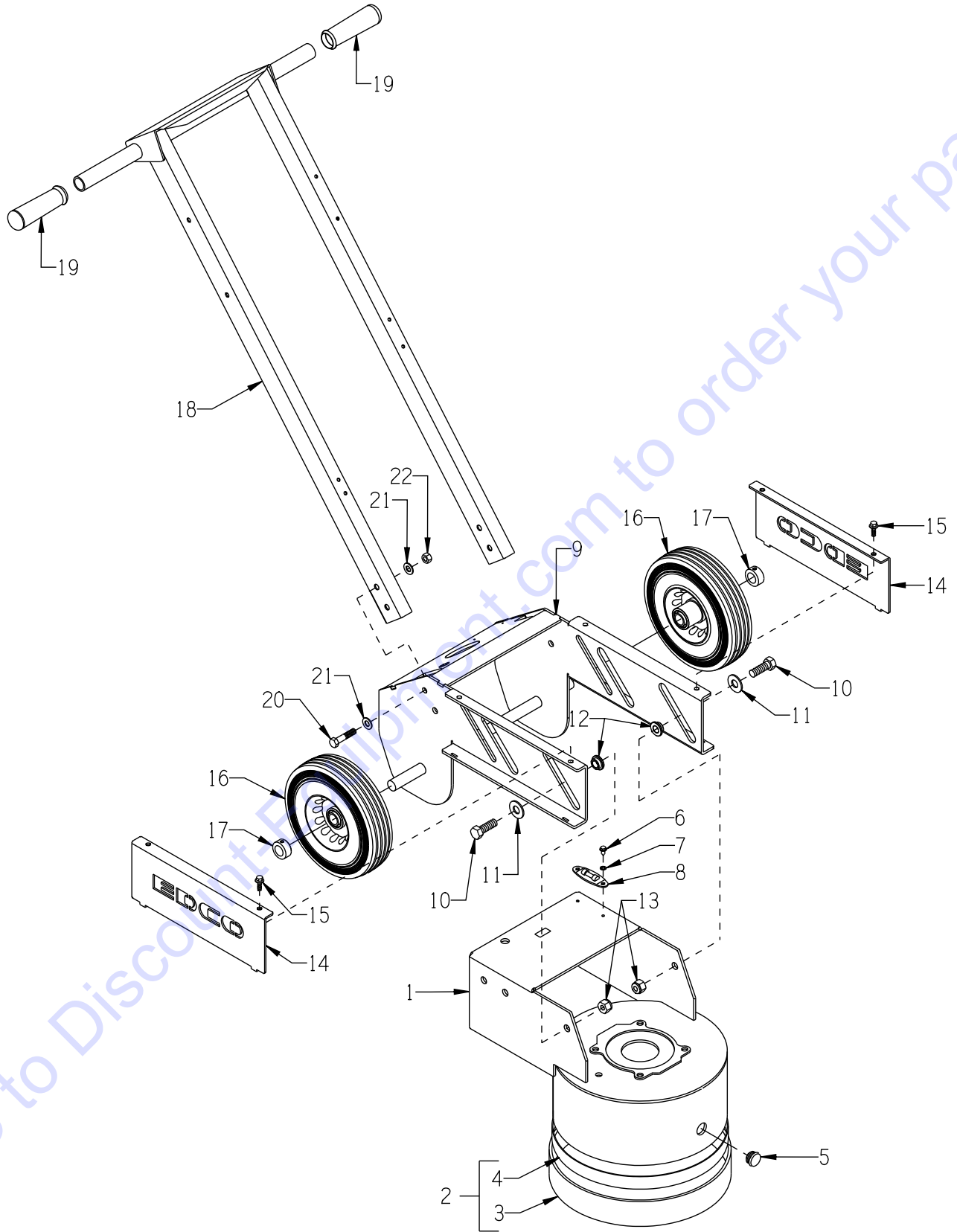
TABLE OF CONTENTS

<u>Section</u>	<u>Pages</u>
Safety Messages and General Instructions	2
How To Order Replacement Parts	3
Illustration 1: Frame Grouping	4, 5
Illustration 2: Locking Lever Grouping	6, 7
Illustration 3: Vacuum Port & Water Hook-Up Grouping	8, 9
Illustration 4: Motor, Speed Reducer & Disc Assembly	10, 11
Illustration 5: Quick-Change Multi-Accessory Disc Assembly	12
Illustration 6: Optional Diamond Disc Adapter	13
Illustration 7: Switch and Power Cord Grouping	14, 15
Switch Wiring Diagram	16
Motor Wiring Diagram	17
Decal Sheet	18
Decal Continued.	19
Limited Equipment Warranty of Sale - Terms & Conditions	20 (Back Page)



A Division of Equipment Development Company, Inc.

ILLUSTRATION 1: FRAME GROUPING

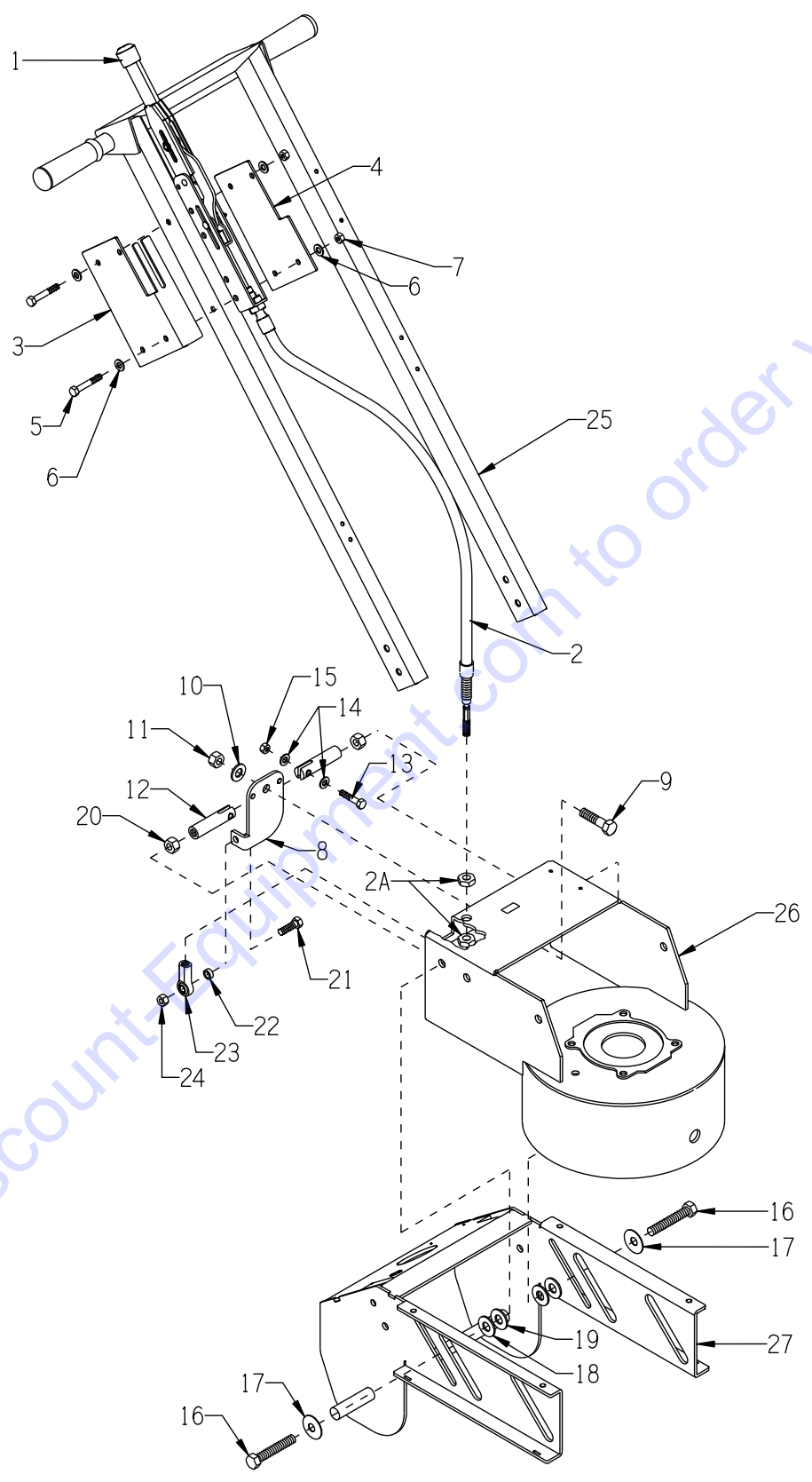


PARTS LISTING - ILLUSTRATION 1: FRAME GROUPING			
ITEM #	PART #	DESCRIPTION	QTY.
1	86802	INNER FRAME & SHROUD, SEC-NG	1
2	86426K	RUBBER SKIRT W/ VELCRO LOOP & HOOK	1
3	86426	RUBBER SKIRT W/ VELCRO-LOOP NOTE: CUT 37-3/8"	1
4	86427	VELCRO-HOOK ONLY, 1" X 39" (CUT DOWN)	1
5	77528	PLUG, BLACK 1"RD. TUBING 10-14 GA.	1
6	10877	SCREW, CAP STSHW 10-24 X 1/2	2
7	10831	WASHER, LOCK, INT. TOOTH #10	2
8	59117	LEVEL, SCREW ON	1
9	86801	FRAME, OUTER, SEC-NG	1
10	10308	SCREW, CAP 1/2-20 X 1-1/2	4
11	77623	WASHER, FLAT 1/2" SILICON BRONZE	4
12	77622M	FLANGED-SLEEVE, BRONZE (MODIFIED)	4
13	10154	NUT, HEX NYLON LOCK 1/2-20 ZINC	4
14	86815	COVER, SIDE, SEC-NG	2
15	11811	BOLT, FLANGE 1/4-20 X 3/4 ZINC	4
16	79013SH	WHEEL, STL.HUB 8 X 2-1/2 X 3/4"BRG.	2
17	10428	COLLAR, LOCKING 3/4"ID	2
18	86804	HANDLE BAR, SEC-NG	1
19	10608	GRIP, HAND 1" MODEL AT	2
20	10029	SCREW, CAP 3/8-24 X 1-3/4	4
21	10025	WASHER, FLAT 3/8 SAE ZINC	8
22	10004	NUT, HEX LOCK 3/8-24 ZINC	4



A Division of Equipment Development Company, Inc.

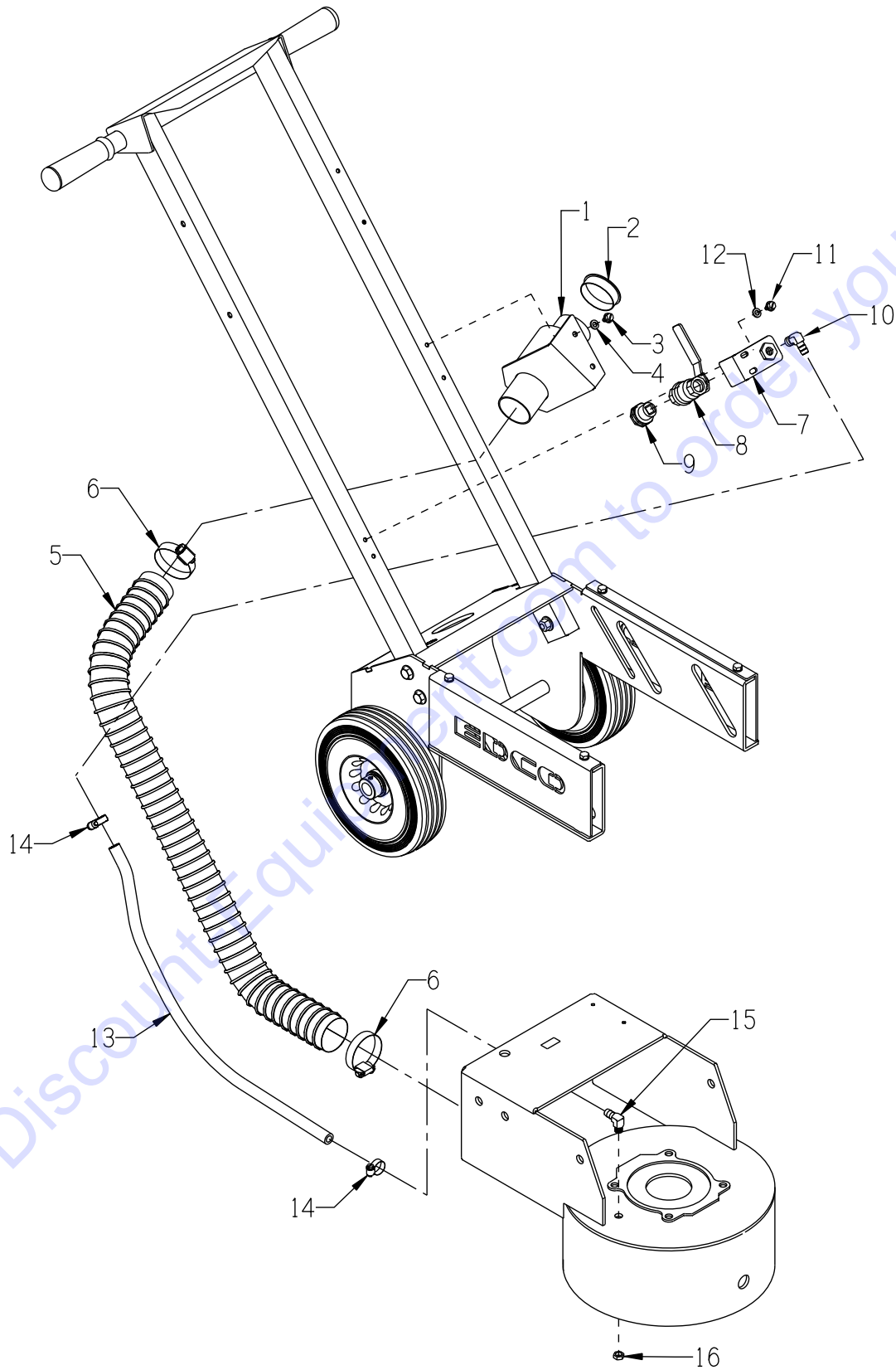
ILLUSTRATION 2: LOCKING LEVER GROUPING



PARTS LISTING - ILLUSTRATION 2: LOCKING LEVER GROUPING			
ITEM #	PART #	DESCRIPTION	QTY.
1	77620	LEVER, LOCKING	1
2	77621	CABLE, LOCKING LEVER	1
2A	-----	JAM NUT (INCLUDED W/ CABLE, ITEM 2)	2
3	86806	BRACKET 2, LOCKING LEVER	1
4	86805	BRACKET 1, LOCKING LEVER	1
5	10204	SCREW, CAP 5/16-18 X 1-3/4	4
6	10213	WASHER, FLAT 5/16 SAE ZINC	8
7	10151	NUT, HEX NYLON LOCK 5/16-18 ZINC	4
8	77610	PIVOT BRACKET, LOCKING LEVER	1
9	10308	SCREW, CAP 1/2-20 X 1-1/2	1
10	10312	WASHER, FLAT 1/2 SAE ZINC	1
11	10154	NUT, HEX NYLON LOCK 1/2-20 ZINC	1
12	86807	PIVOT LINKAGE BAR, LOCKING LEVER	2
13	10606	SCREW, CAP 5/16-18 X 1-1/4	2
14	10213	WASHER, FLAT 5/16 SAE ZINC	4
15	10151	NUT, HEX NYLON LOCK 5/16-18 ZINC	2
16	10347	SCREW, CAP 1/2-20 X 2-1/4	2
17	10433	WASHER, BELLEVILLE 1/2ID X 3/32THK	2
18	77623	WASHER, FLAT 1/2" SILICON BRONZE .562"ID x 1.25"OD x .091"THK	2
19	10040 12121	WASHER, GARRET 17/32 X 1 X .054 WASHER, 1"OD X 17/32"ID X 21G(.033) (*USE EITHER WASHER AS NEEDED IN PLACE OF OR IN ADDITION TO ITEM 18)	2* 2*
20	10072	NUT, HEX 1/2-20 ZINC	2
21	10309	SCREW, CAP 3/8-24 X 1-1/4 ZINC	1
22	10113	SPACER, STEEL 9/16OD X 3/8ID X 7/32	1
23	10919	ROD END, FEMALE 3/8-24 R.H. THREAD	1
24	10004	NUT, HEX LOCK 3/8-24 ZINC	1
25	77607	HANDLE BAR (REFER TO ILLUS. 1, ITEM 18)	1
26	86802	INNER FRAME & SHROUD (REFER TO ILLUS. 1, ITEM 1)	1
27	86801	FRAME, OUTER (REFER TO ILLUS. 1, ITEM 9)	1



ILLUSTRATION 3: VACUUM PORT & WATER HOOK-UP GROUPING

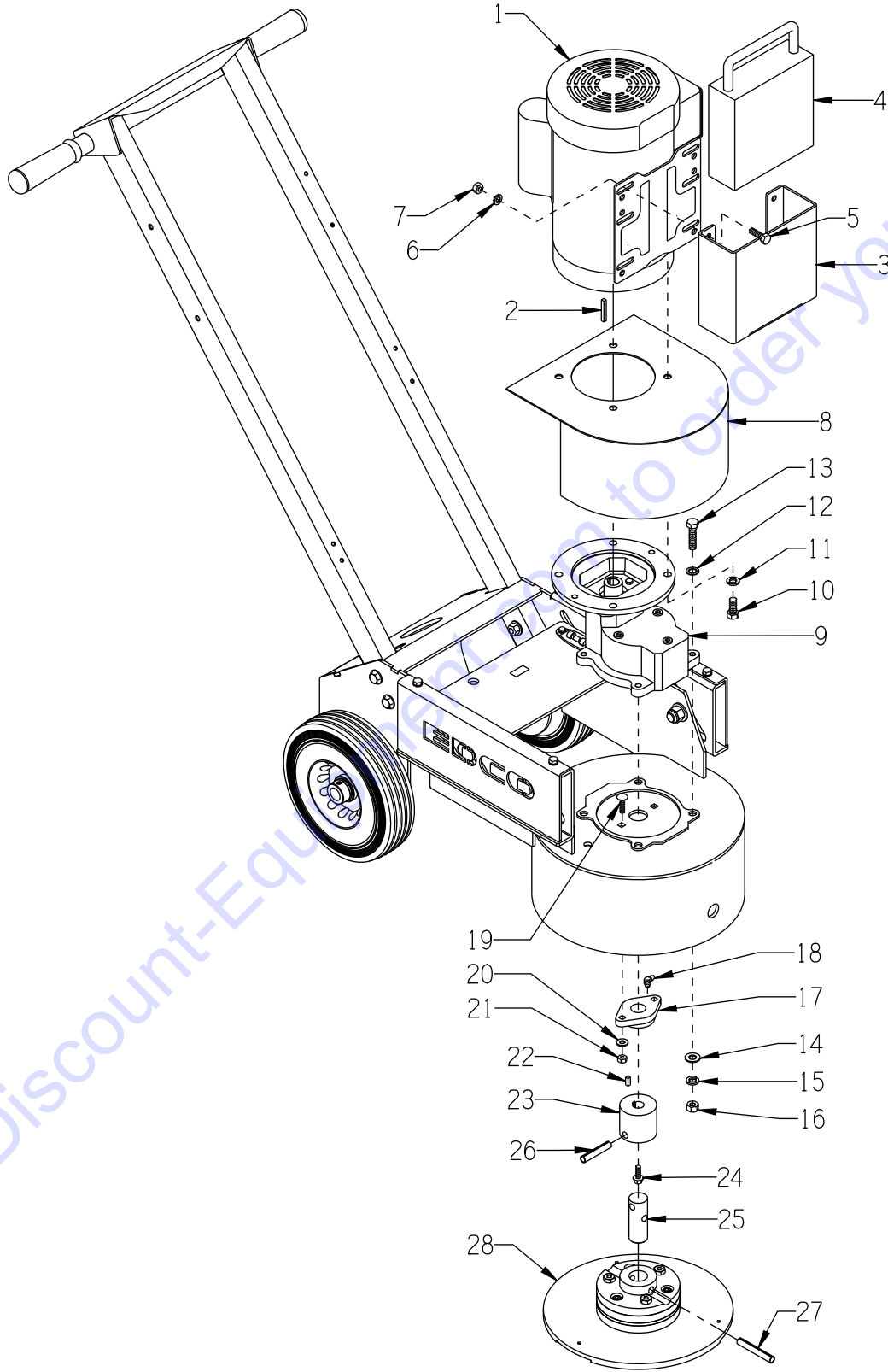


PARTS LISTING - ILLUSTRATION 3: VACUUM PORT & WATER HOOK-UP GROUPING			
ITEM #	PART #	DESCRIPTION	QTY.
1	86347	BRACKET, MULTI-VAC PORT 2-3"	1
2	65021	CAP/PLUG 2" RED PLASTIC, FLANGED	1
3	10846	SCREW, CAP STSHW 1/4-20 X 1/2	2
4	10038	WASHER, LOCK 1/4 ZINC	2
5	77113	HOSE, FLEX 2"ID X 32"L, GRINDERS	1
6	10766	CLAMP, HOSE, SAE #32, ADJ. TO 2-1/2	2
7	56022	BRACKET, WATER VALVE	1
8	10711	VALVE, BALL 1/2 FPT	1
9	80021	CONN., SWIVEL FEM. 3/4HOSE X 1/2MPT	1
10	10799	BARB ELBOW 90, 3/8HOSE X 1/4MPT	1
11	10846	SCREW, CAP STSHW 1/4-20 X 1/2	2
12	10038	WASHER, LOCK 1/4 ZINC	2
13	56315	HOSE, WATER 3/8"ID X 24"L	1
14	50069	CLAMP, HOSE, SAE #6, ADJ. TO 13/16	2
15	11562	BARB ELBOW 90, 3/8HOSE X 1/8MPT	1
16	10864	NUT 1/8-27 PIPE THREAD (BRASS)	1



A Division of Equipment Development Company, Inc.

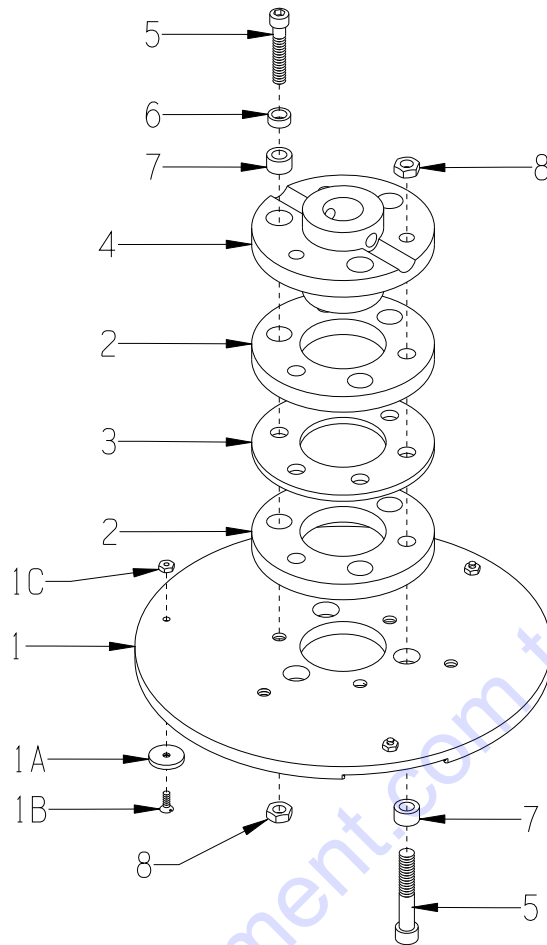
**ILLUSTRATION 4:
MOTOR, SPEED REDUCER & DISC GROUPING**



PARTS LISTING - ILLUSTRATION 4: MOTOR, SPEED REDUCER & DISC GROUPING			
ITEM #	PART #	DESCRIPTION	QTY.
1	16081	MOTOR, 1.5HP-1PH-60HZ-1725RPM-115/230V	1
		<i>REPLACEMENT PARTS:</i>	
	16178.....CAPACITOR, START, LEESON 003025.15 (500MFD 125V)	1
	16174.....CAPACITOR, RUN, LEESON 003014.02 (50MFD 240V)	1
	16179.....RESET BUTTON, LEESON 300033.02 (CED2705)	1
2	-----	KEY 3/16"SQ. X 1-3/8 (INCLUDED W/ MOTOR)	1
3	86808	HOLDER, WEIGHT, SEC-NG	1
4	86809	WEIGHT BLOCK, 21 LB., SEC-NG	1
5	10806	SCREW, CAP 5/16-18 X 1	4
6	10801	WASHER, LOCK 5/16 ZINC	4
7	10054	NUT, HEX 5/16-18 ZINC	4
8	86803	COVER, SPEED REDUCER	1
9	76029	SPEED REDUCER, 2.056 RATIO	1
10	10055	SCREW, CAP 3/8-16 X 1	4
11	10811	WASHER, LOCK 3/8 ZINC	4
12	10453	WASHER, LOCK, INT. TOOTH 3/8"	4
13	10480	BOLT, TAP 3/8-16 X 1-1/2 (FULL THD)	4
14	10025	WASHER, FLAT 3/8 SAE ZINC	4
15	10811	WASHER, LOCK 3/8 ZINC	4
16	10404	NUT, HEX 3/8-16 ZINC	4
17	80009G	BEARING, BALL 5/8" 2-HOLE	1
18	10960	FITTING, GREASE 1/4-28 X 45°	1
19	10412	BOLT, CARRIAGE 1/4-20 X 1	2
20	10602	WASHER, FLAT 1/4 SAE ZINC	2
21	10861	NUT, KEPS LOCK 1/4-20 ZINC	2
22	10142	KEY 3/16SQ X 3/4	1
23	86810	COUPLING, SHAFT, SEC-NG	1
24	11811	BOLT, FLANGE 1/4-20 X 3/4 ZINC	1
25	86811	SHAFT, DISC, SEC-NG	1
26	10063	PIN, ROLL 3/8 X 2	1
27	10007	PIN, ROLL 3/8 X 2-1/2	1
28	86391A	QC MULTI-ACCY. 10" DISC ASSY.W/ HUB (REFER TO ILLUS. 5 FOR BREAKDOWN)	1

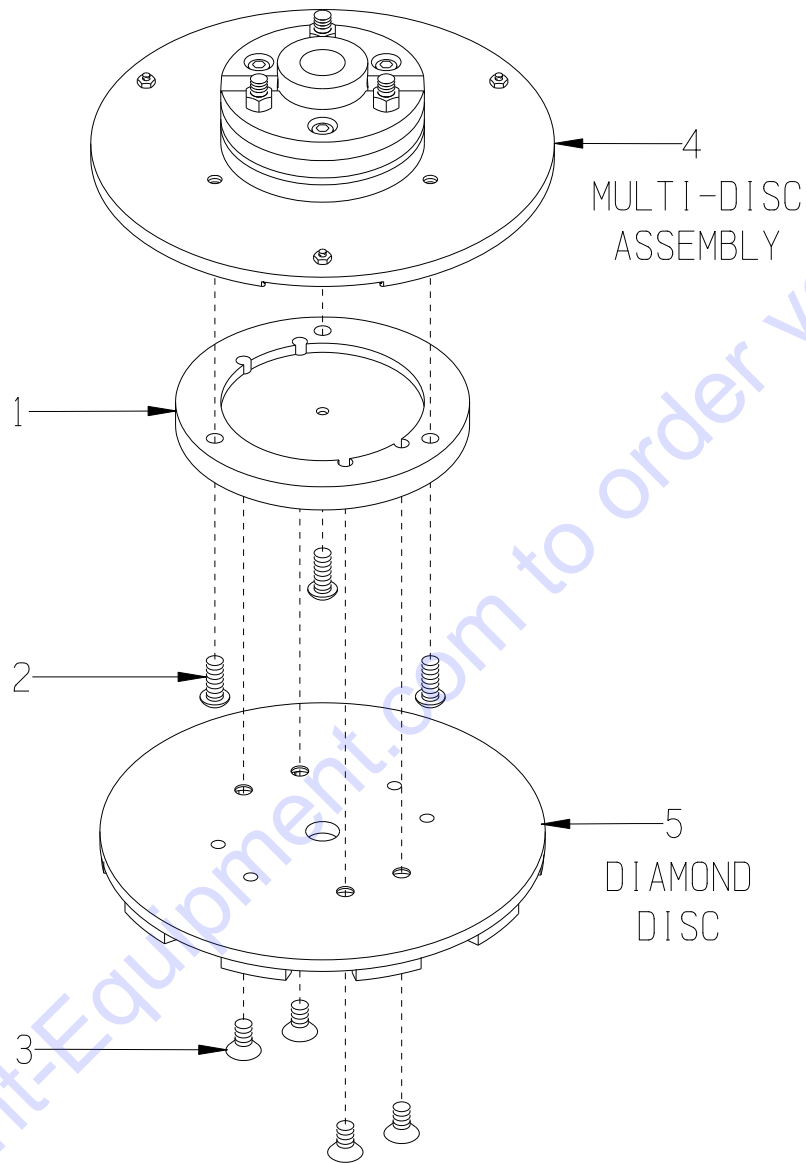


ILLUSTRATION 5: QUICK-CHANGE MULTI-ACCESSORY DISC ASSEMBLY



ITEM #	PART #	DESCRIPTION	QTY.*
1-8	86391A	QC MULTI-ACCY. 10" DISC ASSY.W/ HUB (INCLUDES ITEMS 1 THRU 8)	1
1	86391	QC MULTI-ACCY. 10" DISC W/ MAGNETS (INCLUDES ITEMS 1A, 1B AND 1C)	1
1A	36064	MAGNET, NEODYMIUM RING 7/8 X 1/8	3
1B	10647	SCREW, FLAT HD PHILLIPS 8-32 X 1/2	3
1C	10462	NUT, KEPS LOCK 8-32 ZINC	3
2	10112	RING, RUBBER, 4-1/2"OD X 1/2"THK	2
3	77020	RING, HUB CARRIER, 6-HOLE	1
4	77010	HUB, ALUMINUM 6-HOLE (GRINDER)	1
5	10354	SCREW, SKT. HD. CAP 3/8-24 X 1-3/4	6
6	10113	SPACER, STEEL 9/16OD X 3/8ID X 7/32	3
7	10011	SPACER, STEEL 5/8OD X 3/8ID X 3/8T	6
8	11725	NUT, HEX JAM 3/8-24 ZINC (USE BLUE LOCTITE)	6
* QUANTITIES ARE PER EACH DISC ASSEMBLY. THERE IS 1 DISC ASSEMBLY PER MACHINE.			

**ILLUSTRATION 6:
OPTIONAL DIAMOND DISC ADAPTER**

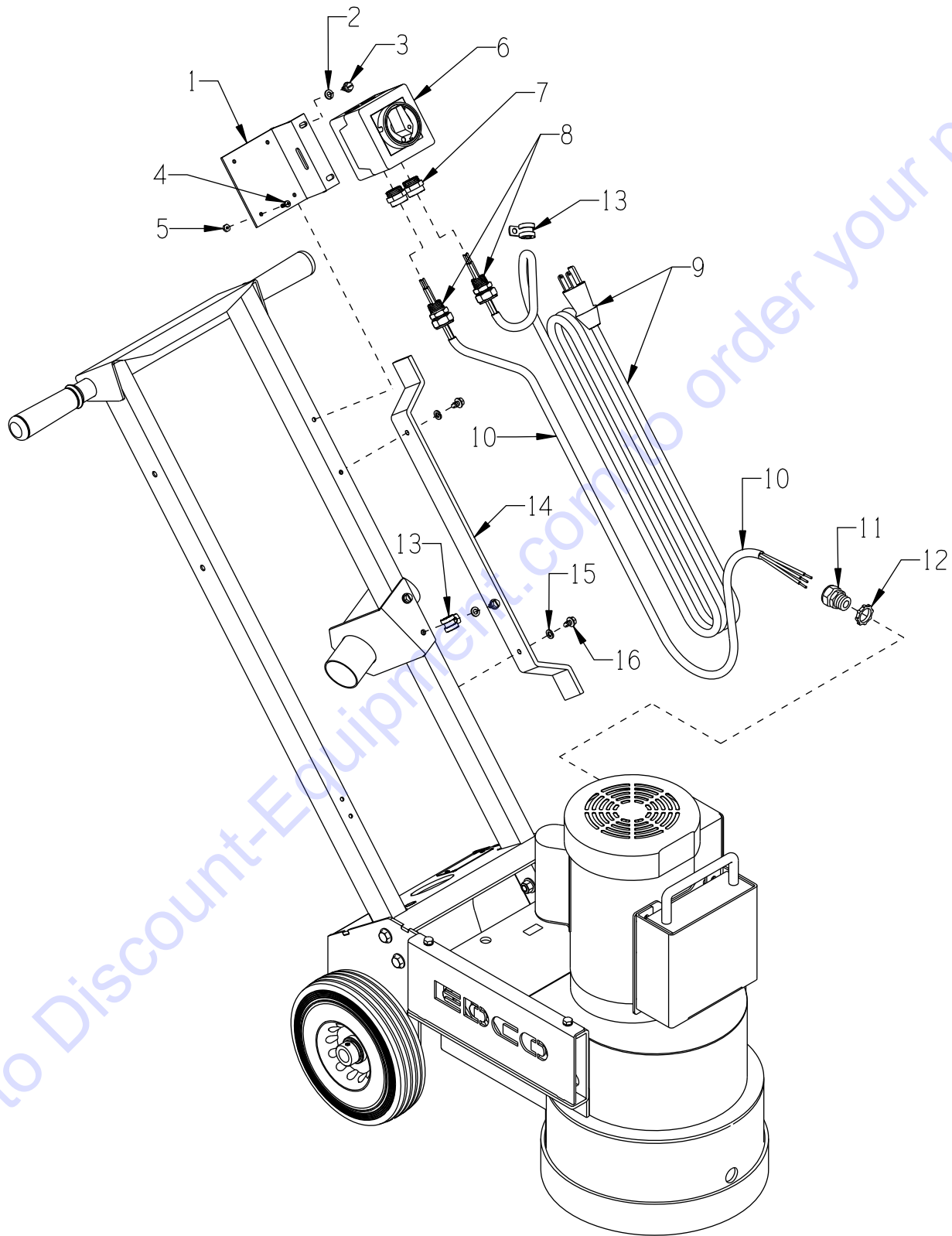


ITEM #	PART #	DESCRIPTION	QTY.*
1	77618	ADAPTER, DIAMOND DISC (INCLUDES ITEM 2)	1
2	10855	SCREW, SKT. BUTTON HD 3/8-24 X 1	3
3	86108	SCREW, FLAT HD SKT 3/8-24 X 3/4 (NOT INCLUDED)	-
4	86391A	MULTI-DISC ASSEMBLY (NOT INCLUDED)	-
5	-----	DIAMOND DISC (NOT INCLUDED) REFER TO CATALOG FOR OPTIONS.	-
<p>* QUANTITIES ARE PER EACH DISC ASSEMBLY. THERE IS 1 DISC ASSEMBLY PER MACHINE.</p>			



A Division of Equipment Development Company, Inc.

**ILLUSTRATION 7:
SWITCH AND POWER CORD GROUPING**

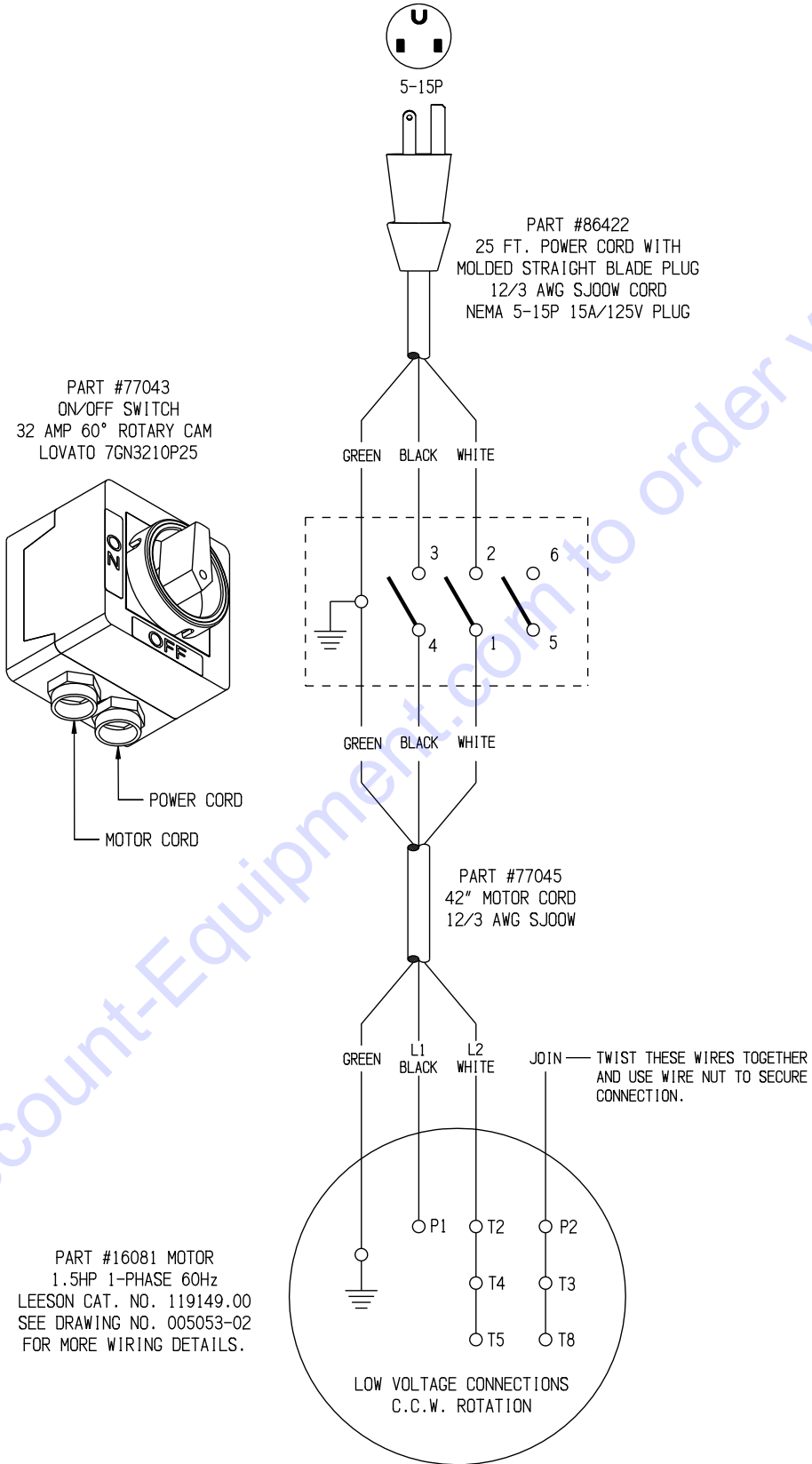


PARTS LISTING - ILLUSTRATION 7: SWITCH AND POWER CORD GROUPING			
ITEM #	PART #	DESCRIPTION	QTY.
1	77042	BRACKET, ROTARY CAM SWITCH	1
2	10038	WASHER, LOCK 1/4 ZINC	2
3	10846	SCREW, CAP STSHW 1/4-20 X 1/2	2
4	11663	SCREW, MACHINE 8-32 X 1/2 RHCD ZINC	2
5	10462	NUT, KEPS LOCK 8-32 ZINC	2
6	77043	SWITCH, ROTARY CAM ON/OFF, LOVATO	1
		<u>REPLACEMENT PARTS:</u>	
	77043-2...SWITCH HANDLE, PADLOCKABLE	1
	77043-4...GASKET RING, OPERATOR	1
7	77043-1	SWITCH ADAPTER, PG16 TO 1/2"NPT	2
8	40066	STRAIN RELIEF 1/2NPT X .350-.450"	2
9	86422	CORD W/ PLUG, 25FT. POWER	1
10	77045	WIRE HARNESS 12/3 X 42"LOA	1
11	16176	STRAIN RELIEF 3/4NPT X .350-.450"	1
12	10740	CONDUIT LOCK NUT 3/4 NP	1
13	11690	CLAMP, LOOM, 3/8"	2
14	86419	HOLDER, POWER CORD	1
15	10038	WASHER, LOCK 1/4 ZINC	2
16	10846	SCREW, CAP STSHW 1/4-20 X 1/2	2



A Division of Equipment Development Company, Inc.

SWITCH WIRING DIAGRAM



MOTOR WIRING DIAGRAM

LEESON CAT. NO. 119149
1.5HP 60Hz SINGLE PHASE

USE CONNECTIONS FOR COUNTER CLOCK-WISE (C.C.W.) ROTATION SHOWN BELOW IN CHART
POWER CORD: BLACK WIRE - L1, WHITE WIRE - L2, GREEN WIRE - GROUND
LOW VOLT (115V) STANDARD, HIGH VOLT (230V) OPTIONAL

005053-02

VIEW FROM OUTSIDE OF MOTOR AT SWITCH END.

LINE LEADS

	ROTATION FACING LEAD END	L1	L2	JOIN	INSULATE SEPARATELY
HIGH VOLT	C.C.W.	P1	T4 T5	T2, T3 T8	P2
	C.W.	P1	T4 T8	T2, T3 T5	P2
LOW VOLT	C.C.W.	P1	T2, T4 T5	P2, T3 T8	-----
	C.W.	P1	T2, T4 T8	P2, T3 T5	-----

* THIS LEAD MAY BE WHITE

		TOLERANCES UNLESS SPECIFIED		REGAL-BELOIT <i>Motor Technologies Group</i>	DRAWN ADH 06/16/76	
		DEC.	INCHES		CHK	WRK
		.X	±.1	TITLE EXTERNAL WIRING DIAGRAM TYPE "K" W/PROTECTOR MAT'L DECAL 004011 FINISH CAD FILE 00505302 SIZE DRAWING NO. A 005053-02	CHK WRK 06/30/76	
04	ADDED "*" TO T5	.XX	±.01		APPD	SCALE 1=1
03	REDRAWN ON CAD	.XXX	±.005		REF	FMF 6K17FB8A
NO.	REVISION	BY & DATE	CHK	ANG	±1/2"	PREV
THIS DRAWING IN DESIGN AND DETAIL IS OUR PROPERTY AND MUST NOT BE USED EXCEPT IN CONNECTION WITH OUR WORK ALL RIGHTS OF DESIGN AND INVENTION ARE RESERVED THIS IS AN ELECTRONICALLY GENERATED DOCUMENT - DO NOT SCALE THIS PRINT				RFP		REV. 04
				DIST		

6/28/2007 5:11:39 PM -

PARTS FINDER

**Search Website
by Part Number**



**Search Manual
Library For Parts
Manual & Lookup Part
Numbers – Purchase
or Request Quote**

Search Manuals

Enter your information to help us find the right parts manual for your machine.

* Brand:

* Model:

* Serial:

* Part Number:

SEARCH

**Can't Find Part or
Manual? Request Help
by Manufacturer,
Model & Description**

Parts Order Form

Please fill in the following information to help us find the right part for your machine.

Manufacturer:	<input type="text"/>
Model:	<input type="text"/>
Description:	<input type="text"/>
Part Number:	<input type="text"/>
Quantity:	<input type="text"/>
Notes:	<input type="text"/>

Submit

Discount-Equipment.com is your online resource for quality parts & equipment.

Florida: **561-964-4949** Outside Florida TOLL FREE: **877-690-3101**

Need parts?

Click on this link: <http://www.discount-equipment.com/category/5443-parts/> and choose one of the options to help get the right parts and equipment you are looking for. Please have the machine model and serial number available in order to help us get you the correct parts. If you don't find the part on the website or on one of the online manuals, please fill out the request form and one of our experienced staff members will get back to you with a quote for the right part that your machine needs.

We sell worldwide for the brands: Genie, Terex, JLG, MultiQuip, Mikasa, Essick, Whiteman, Mayco, Toro Stone, Diamond Products, Generac Magnum, Airman, Haulotte, Barreto, Power Blanket, Nifty Lift, Atlas Copco, Chicago Pneumatic, Allmand, Miller Curber, Skyjack, Lull, Skytrak, Tsurumi, Husquvarna Target, Stow, Wacker, Sakai, Mi-T-M, Sullair, Basic, Dynapac, MBW, Weber, Bartell, Bennar Newman, Haulotte, Ditch Runner, Menegotti, Morrison, Contec, Buddy, Crown, Edco, Wyco, Bomag, Laymor, EZ Trench, Bil-Jax, F.S. Curtis, Gehl Pavers, Heli, Honda, ICS/PowerGrit, IHI, Partner, Imer, Clipper, MMD, Koshin, Rice, CH&E, General Equipment, Amida, Coleman, NAC, Gradall, Square Shooter, Kent, Stanley, Tamco, Toku, Hatz, Kohler, Robin, Wisconsin, Northrock, Oztec, Toker TK, Rol-Air, APT, Wylie, Ingersoll Rand / Doosan, Innovatech, Con X, Ammann, Mecalac, Makinex, Smith Surface Prep, Small Line, Wanco, Yanmar