

REVISED STARTING SERIAL # 061010077



PARTS MANUAL MODEL SEC



SINGLE-DISC CONCRETE FLOOR GRINDER

SKU NO.	MODEL NO.	POWER OPTION
50200	SEC-1.5L	LEESON MOTOR 1.5HP-1PHASE-60HZ-115/230 VOLT-17.2/8.6 AMPS
52500	SEC-1.75L/50/1	LEESON MOTOR 1.75HP-1PHASE-50HZ-110/220 VOLT-18.8/9.4 AMPS

The EDCO logo, consisting of the letters "EDCO" in a bold, white, sans-serif font on a black rectangular background.

PARTS FINDER

**Search Website
by Part Number**



**Search Manual
Library For Parts
Manual & Lookup Part
Numbers – Purchase
or Request Quote**

Search Manuals

Enter your information to help us find the right parts manual for your machine.

* Brand:

* Model:

* Serial:

* Part Number:

SEARCH

**Can't Find Part or
Manual? Request Help
by Manufacturer,
Model & Description**

Parts Order Form

Please fill in the following information to help us find the right part for your machine.

Manufacturer:	<input type="text"/>
Model:	<input type="text"/>
Description:	<input type="text"/>
Part Number:	<input type="text"/>
Quantity:	<input type="text"/>
Notes:	<input type="text"/>

Submit

Discount-Equipment.com is your online resource for quality parts & equipment.

Florida: **561-964-4949** Outside Florida TOLL FREE: **877-690-3101**

Need parts?

Click on this link: <http://www.discount-equipment.com/category/5443-parts/> and choose one of the options to help get the right parts and equipment you are looking for. Please have the machine model and serial number available in order to help us get you the correct parts. If you don't find the part on the website or on one of the online manuals, please fill out the request form and one of our experienced staff members will get back to you with a quote for the right part that your machine needs.

We sell worldwide for the brands: Genie, Terex, JLG, MultiQuip, Mikasa, Essick, Whiteman, Mayco, Toro Stone, Diamond Products, Generac Magnum, Airman, Haulotte, Barreto, Power Blanket, Nifty Lift, Atlas Copco, Chicago Pneumatic, Allmand, Miller Curber, Skyjack, Lull, Skytrak, Tsurumi, Husquvarna Target, Stow, Wacker, Sakai, Mi-T-M, Sullair, Basic, Dynapac, MBW, Weber, Bartell, Bennar Newman, Haulotte, Ditch Runner, Menegotti, Morrison, Contec, Buddy, Crown, Edco, Wyco, Bomag, Laymor, EZ Trench, Bil-Jax, F.S. Curtis, Gehl Pavers, Heli, Honda, ICS/PowerGrit, IHI, Partner, Imer, Clipper, MMD, Koshin, Rice, CH&E, General Equipment, Amida, Coleman, NAC, Gradall, Square Shooter, Kent, Stanley, Tamco, Toku, Hatz, Kohler, Robin, Wisconsin, Northrock, Oztec, Toker TK, Rol-Air, APT, Wylie, Ingersoll Rand / Doosan, Innovatech, Con X, Ammann, Mecalac, Makinex, Smith Surface Prep, Small Line, Wanco, Yanmar

READ AND UNDERSTAND THE OPERATORS INSTRUCTION MANUAL THOROUGHLY BEFORE ATTEMPTING TO OPERATE THIS EQUIPMENT. Death or serious injury could occur if this machine is used improperly.



SAFETY MESSAGES



The safety instructions are preceded by a graphic alert message of DANGER, WARNING, or CAUTION.



Indicates an imminent hazard which, if not avoided, will result in death or serious injury.



Indicates an imminent hazard which, if not avoided, can result in death or serious injury.



Indicates hazards which, if not avoided, could result in serious injury and or damage to the equipment.

GASOLINE Powered Equipment



- Do not operate gasoline powered equipment without adequate ventilation. Carbon monoxide is an invisible, odorless gas that can kill.

ELECTRICAL Powered Equipment



- ELECTRICAL HAZARD** - Be sure equipment is properly grounded. Failure to comply could kill or result in serious injury.



The engine exhaust from this product contains chemicals known to the State of California to cause cancer, birth defects or other reproductive harm.

GENERAL INSTRUCTIONS



- You must read and understand the operators instruction manual and all other manuals associated with this machine. For your safety and the safety of others around you, it is extremely important to fully understand how to operate this machine in the way it was intended. Different model machines or older/newer versions of the same model may have different parts and controls that you need to understand. If instructions are not readable or available DO NOT USE this machine and contact Discount-equipment for a replacement Manual.
- You must be able to physically handle the bulk weight and power of this machine. If not properly controlled this machine can cause death or serious injury.
- Do not operate this machine in an impaired mental state. You must be able to exercise good judgement and reactions to maintain a safe working environment.
- This is a "one person" machine which means only one operator can be operating the machine at any one time. For the safety of others, maintain a safe operating distance to other personnel. Your work area should be defined and appropriately marked so bystanders and coworkers do not stand or walk near this machine and end up seriously injured by flying debris or exposing them to harmful noise or dust.
- This equipment is for Commercial use. Although this is a "one person" machine your work team should understand how to shut this machine off and quickly get medical help if an accident strikes the operator.
- Keep all guards in place during operation. The guards are to provide protection from inadvertent contact with dangerous moving parts, pinch points, or hot surfaces.
- Wear appropriate Personal Protective Equipment (PPE) including safety glasses, safety boots, work gloves, respiratory protection, hearing protection, and head protection. Do not wear loose clothing that can get tangled in moving parts. Failure to do so could result

in dismemberment or death. **Wear an approved respirator when removing hazardous materials or when grinding/cutting dry materials. Some dust particles such as concrete dust can contain silicate particles which can cause silicosis (a very serious lung disease). Contact NIOSH or OSHA for further details. When wet grinding/cutting, avoid contact with the concrete/asphalt slurry which can cause serious skin irritations.**

- You must maintain this machine per the maintenance schedule in the operator manual. Remember before adjusting, servicing, or fueling this machine, disconnect the source of power to the machine by disconnecting the spark plug (Gas models), or by unplugging the electrical power cord (electric models) or air hose (Pneumatic models) AT THE MACHINE so you can assure yourself it remains unplugged while you are working on it. Do not modify this machine. Use only genuine EDCO parts and accessories. Repairs and service should be performed by approved EDCO dealers or authorized technicians.
- You should look carefully around the area before you begin work so you can identify potential hazards such as deck inserts, pipes, columns, openings, electrical cords or outlets, or any other objects protruding from the slab surface.
- This machine has no brain so you must use your own. There is no substitute for safety. The safety decals on the machine are to serve as a reminder for information you must already know before you begin using this machine. Take a moment to reread the safety decals each time you use the machine. If your machine is missing any decals, contact Discount-equipment for a replacement.

PARTS MANUAL

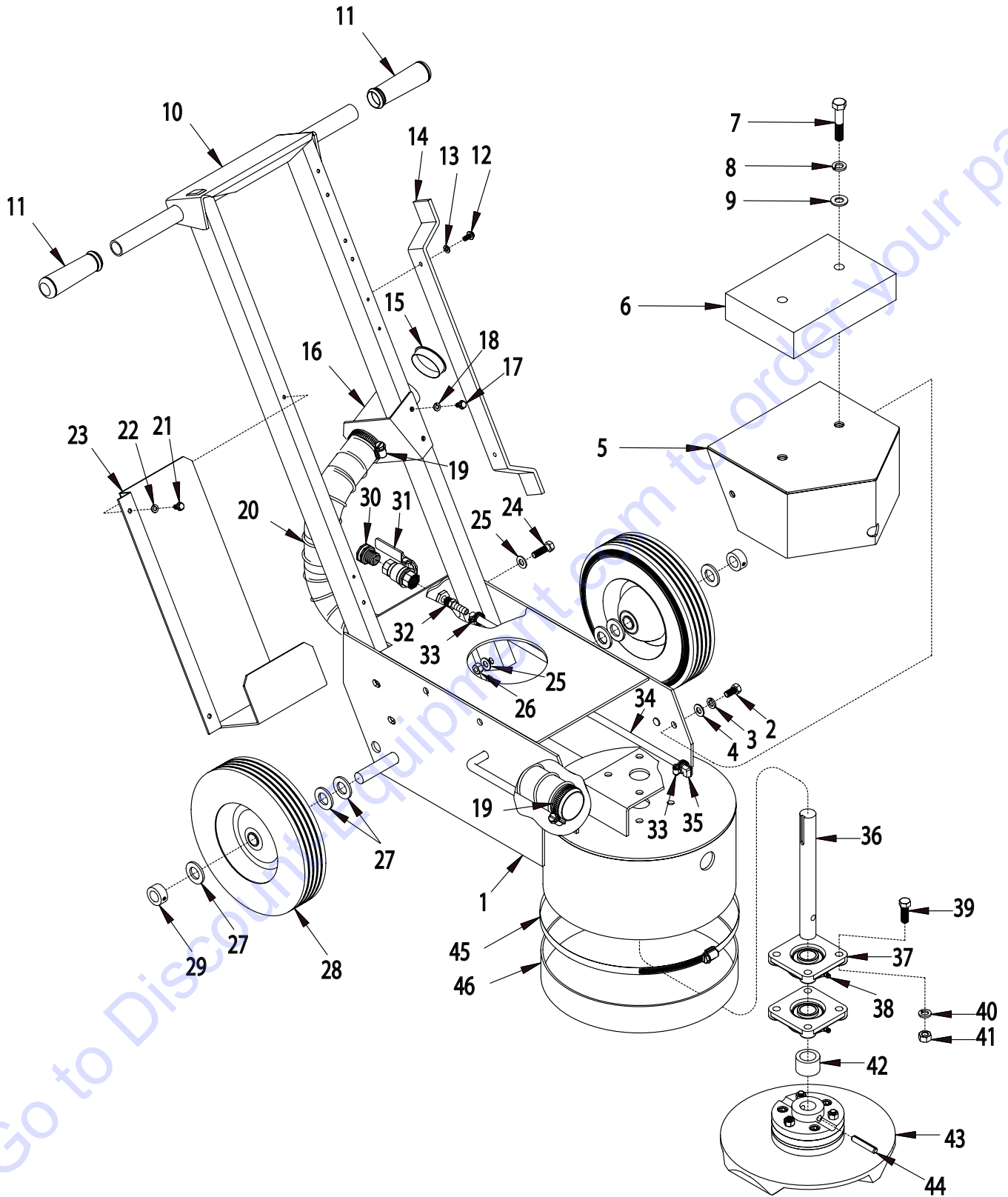
MODEL SEC

<u>Section</u>	<u>Page Number</u>
Safety Messages/General Instructions	2
How To Order Replacement Parts	3
Illustration 1: Main Grouping	4,5
Illustration 2: Motor Grouping	6,7
Illustration 3: Multi-Accessory Disc Assembly	8
Startup Packs	9
Illustration 4: Dyma-Sert™ Accessory	9
Illustration 5: Strip-Sert™ Accessory	10
Illustration 6: Optional Pad Driver Disc Assembly	11
Other Accessories	11
Limited Equipment Warranty	Back Page

Go to Discount-Equipment.com to order your parts



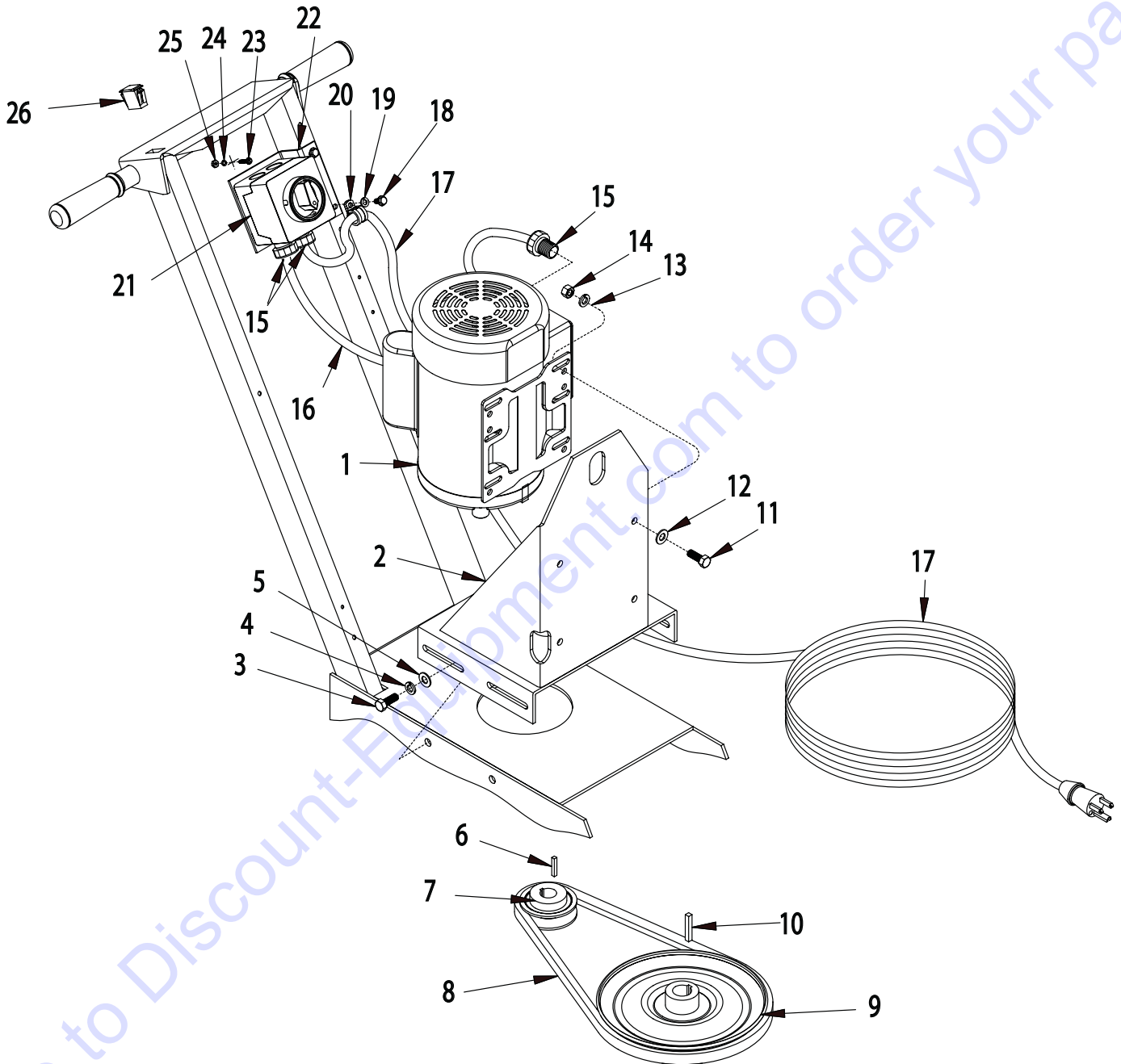
ILLUSTRATION 1 : MAIN GROUPING



PARTS LISTING - ILLUSTRATION 1 : MAIN GROUPING

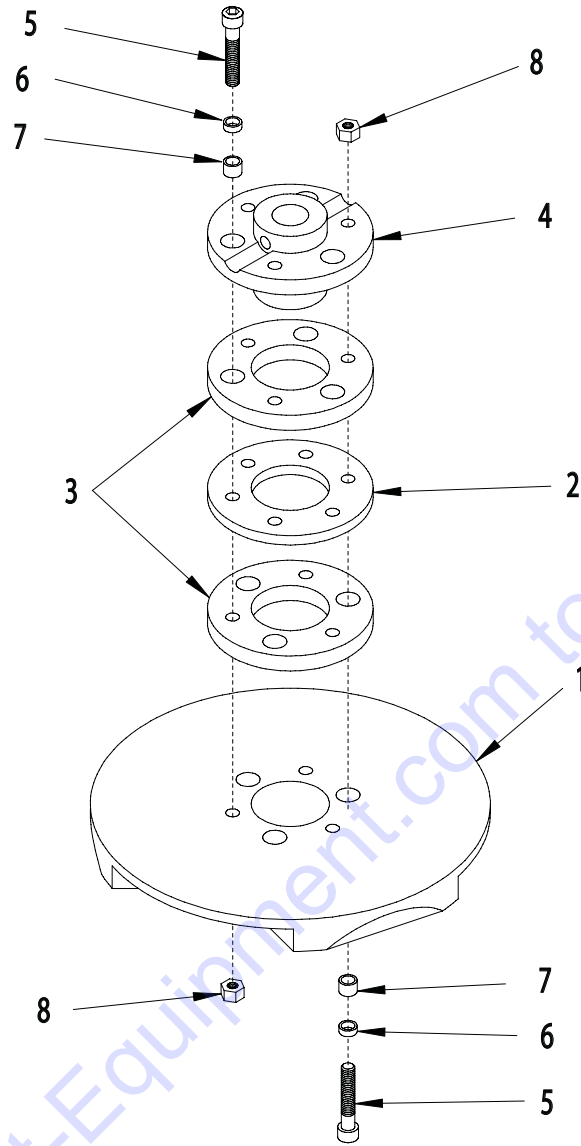
ITEM#	PART#	DESCRIPTION	QTY.	ITEM#	PART#	DESCRIPTION	QTY.
1	86401	MAIN FRAME	1	26	10004	NUT, LOCK 3/8-24	4
2	10907	SCREW, CAP 3/8-16 X 3/4	2	27	10009	WASHER, FLAT 3/4 SAE	6
3	10811	WASHER, LOCK 3/8	2	28	28003	WHEEL 10 X 2-1/4 X 3/4"BRG	2
4	10025	WASHER, FLAT 3/8 SAE	2	29	10428	COLLAR, LOCKING 3/4"ID	2
5	86402	HOOD	1	30	80021	CONN., SWIVEL FEM. 3/4HOSE X 1/2MPT	1
6	86345	WEIGHT BLOCK, 30 LB.	1		10070	WASHER, HOSE 3/4 (INCLUDED W/ ITEM 30)	
7	10323	SCREW, CAP 1/2-13 X 2-1/2	2	31	10711	VALVE, BALL 1/2 FPT	1
8	10045	WASHER, LOCK 1/2	2	32	50075	BARB, 3/8HOSE X 1/4MPT (BRASS)	1
9	10312	WASHER, FLAT 1/2 SAE	2	33	50069	CLAMP, HOSE, SAE #6, ADJ. TO 13/16	2
10	86304	HANDLE BAR	1	34	86424	HOSE 3/8"ID X 20"L	1
11	10608	GRIP, HAND 1" MODEL AT	2	35	11562	BARB ELBOW 90, 3/8 HOSE X 1/8 MPT	1
12	10846	SCREW, CAP STSHW 1/4-20 X 1/2	2		10864	NUT 1/8-27 PIPE THREAD	1
13	10038	WASHER, LOCK 1/4	2	36	86416	SHAFT, DRIVEN 1" X 9"L	1
14	86419	HOLDER, POWER CORD	1	37	77008	BEARING, BALL 1" 4-HOLE FLANGE, ND	2
15	65021	CAP/PLUG 2" RED PLASTIC, FLANGED	1	38	10808	FITTING, GREASE 1/4-28 STRAIGHT	2
16	86347	BRACKET, MULTI-VAC PORT 2-3"	1	39	10003	SCREW, CAP 7/16-20 X 1-1/4	8
17	10846	SCREW, CAP STSHW 1/4-20 X 1/2	2	40	10450	WASHER, LOCK 7/16	8
18	10038	WASHER, LOCK 1/4	2	41	10481	NUT 7/16-20	8
19	10766	CLAMP, HOSE, SAE #28, ADJ. TO 2-1/4	2	42	86232	SPACER 1"	1
20	86328	HOSE, FLEXIBLE 2"ID X 32"	1	43	8888	DISC ASSY. COMPLETE, MULTI-ACCY. RH <i>REFER TO ILLUS. 3 FOR BREAKDOWN</i>	1
21	10846	SCREW, CAP STSHW 1/4-20 X 1/2	2	44	10063	PIN, ROLL 3/8 X 2	1
22	10038	WASHER, LOCK 1/4	2	45	86420	CLAMP, HOSE SAE #200, ADJ. TO 13"	1
23	86417	TRAY, TOOL BOX	1	46	86423	RUBBER SKIRT, 2"H X 38-1/8"L	1
24	10029	SCREW, CAP 3/8-24 X 1-3/4	4				
25	10025	WASHER, FLAT 3/8 SAE	8				

ILLUSTRATION 2 : MOTOR GROUPING

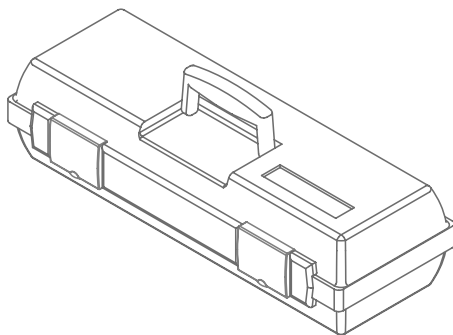


PARTS LISTING - ILLUSTRATION 2 : MOTOR GROUPING			
ITEM#	PART#	DESCRIPTION	QTY.
1	16035	MOTOR, LEESON 1.5HP-1P-60HZ-1725RPM-115/230V	1
		<u>REPLACEMENT PARTS:</u>	
	16159	CAPACITOR, RUN, LEESON 003014.20 (20MFD 240V)	1
	16178	CAPACITOR, START, LEESON 003025.15 (500MFD 125V)	1
	16179	RESET BUTTON, LEESON 300033.02 (CED2705)	1
	16060	MOTOR, LEESON 1.75HP-1PH-50HZ-1425RPM-110/220V	1
		<u>REPLACEMENT PARTS:</u>	
	16191	CAPACITOR, START, LEESON 003025.11 (650MFD 125V)	1
	16183	CAPACITOR, RUN, LEESON 003014.13 (65MFD 240V)	2
	16133	RESET BUTTON, LEESON 2 HP, BRJ42DA	1
2	86404	MOUNT, MOTOR	1
3	10055	SCREW, CAP 3/8-16 X 1	4
4	10811	WASHER, LOCK 3/8	4
5	10025	WASHER, FLAT 3/8 SAE	4
6	-----	KEY 3/16 SQ X 1-3/8 (INCLUDED W/ MOTOR)	1
7	77017	SHEAVE 3"OD X 1GR.B X 7/8"BORE	1
8	10277	BELT BP-38	1
9	86009	SHEAVE 9"OD X 1GR.B X 1"BORE	1
10	40317	KEY 1/4SQ X 1-5/8	1
11	10806	SCREW, CAP 5/16-18 X 1	4
12	10213	WASHER, FLAT 5/16 SAE	4
13	10801	WASHER, LOCK 5/16	4
14	10054	NUT 5/16-18	4
15	40066	STRAIN RELIEF 1/2NPT X .350-.450"	3
	10790	CONDUIT LOCK NUT 1/2 NP	3
16	77045	WIRE HARNESS 12/3 X 42"LOA	1
17	86422	CORD W/ PLUG, 25FT. POWER	1
18	10846	SCREW, CAP STSHW 1/4-20 X 1/2	2
19	10038	WASHER, LOCK 1/4	2
20	11690	CLAMP, LOOM, 3/8"	1
21	77043	SWITCH, ROTARY CAM ON/OFF, LOVATO	1
22	77042	BRACKET, LOVATO ROTARY CAM SWITCH	1
23	11663	SCREW, MACHINE 8-32 X 1/2	4
24	10461	WASHER, LOCK, INT. TOOTH #8	4
25	10462	NUT 8-32	4
26	15204	PLUG, RECT. HOLE, PLASTIC SNAP-IN	1

ILLUSTRATION 3 : MULTI-ACCESSORY DISC ASSEMBLY



#8888 DISC ASSEMBLY COMPLETE, RIGHT HAND (1 REQ'D.)			
ITEM #	PART#	DESCRIPTION	QTY.
1	77088	DISC, MULTI-ACCESSORY R.H. FOR #8888 ASSY.	1
2	77020	RING, HUB CARRIER, 6-HOLE	1
3	10112	RING, NEOPRENE, 4-1/2"ODx1/2"THK	2
4	77010	HUB, ALUMINUM 6-HOLE (GRINDER)	1
5	10114	SCREW, SKT. HD. CAP 3/8-24 X 2-1/4	6
6	10113	SPACER, STEEL 9/16OD X 3/8ID X 7/32"	6
7	10011	SPACER, STEEL 5/8OD X 3/8ID X 3/8"	6
8	10004	NUT, LOCK 3/8-24	6

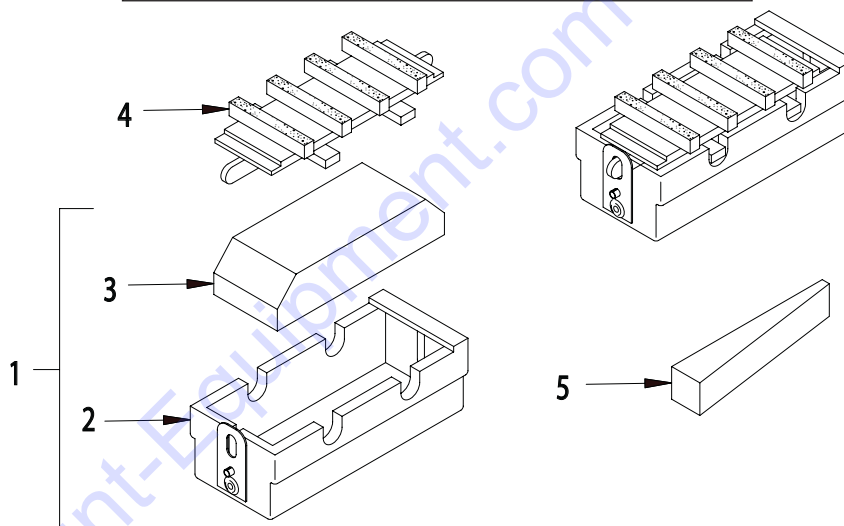


REFER TO ILLUS. 4 FOR BREAKDOWN OF DYMA-SERT ACCESSORY

REFER TO ILLUS. 5 FOR BREAKDOWN OF STRIP-SERT ACCESSORY

STARTUP PACKS	
#A113	GRINDER STARTUP PACK 3 W/ TOOL BOX <i>INCLUDES:</i>
(3)	19110 DYMA-SERT, EG-1X, 30-40 GRIT
(3)	19120 CG221D DYMA-SERT HOLDING CASE W/PAD
(6)	12160 HARDWOOD WEDGE
(1)	12003 HAMMER, BALL PEIN 16 OZ.
(1)	12006 PUNCH, GRINDER WEDGE, 5/8SQ X 9
(1)	12001 TOOL BOX, BLACK, DYMA-SERTS
#A115	GRINDER STARTUP PACK 5 W/ TOOL BOX <i>INCLUDES:</i>
(3)	12400 ASSY. W/ PRO-TUNGSERT
(3)	12402 EXTRA PRO-TUNGSERT
(6)	12160 HARDWOOD WEDGE
(1)	12003 HAMMER, BALL PEIN 16 OZ.
(1)	12006 PUNCH, GRINDER WEDGE, 5/8SQ X 9
(1)	12002 TOOL BOX, RED, STRIP-SERTS

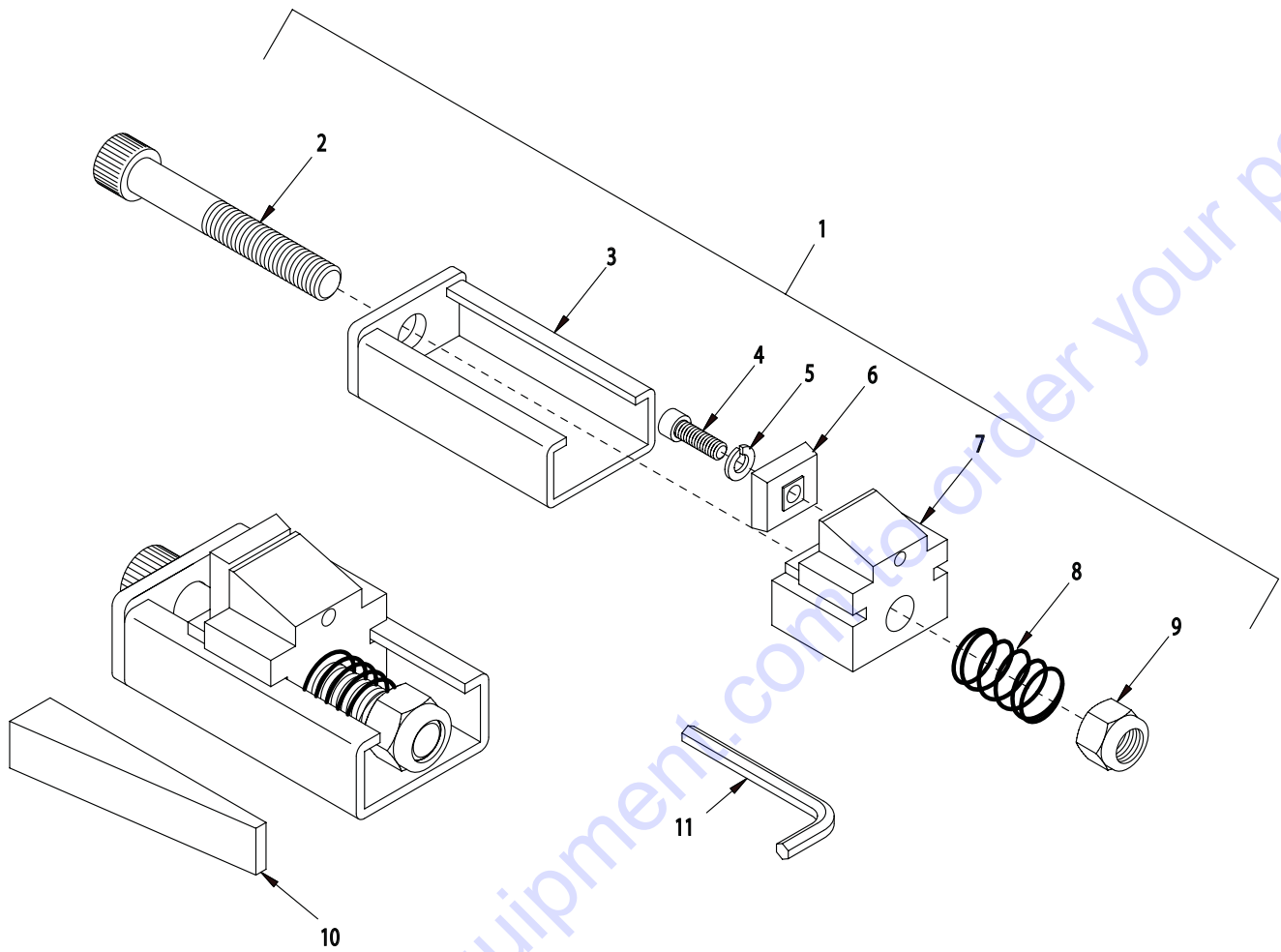
ILLUSTRATION 4 : DYMA-SERT™ ACCESSORY



ITEM#	PART#	DESCRIPTION	QTY.
1	19120	CG221D DYMA-SERT HOLDING CASE W/PAD (INCLUDES ITEMS 2 & 3)	3
2	19121	DYMA-SERT HOLD. CASE INC CLIP & RIVET	1
3	19140	RUBBER SHOCK PAD, DYMA-SERT	1
4	-----	DYMA-SERT ASSEMBLY (SOLD SEPARATELY)	3
	19110	EG-1X, 30-40 GRIT (GENERAL PURPOSE)	
	19130	EG-2X, 30-40 GRIT (ABRASIVE CONCRETE)	
	19180	EG-3X, 30-40 GRIT (EPOXY MORTARS)	
	19250	EG-5X, 50 GRIT (TERRAZZO)	
	19260	EG-7X, 80 GRIT (TERRAZZO)	
	19270	EG-9X, 120 GRIT (TERRAZZO)	
5	12160	WEDGE CG225, HARDWOOD	3

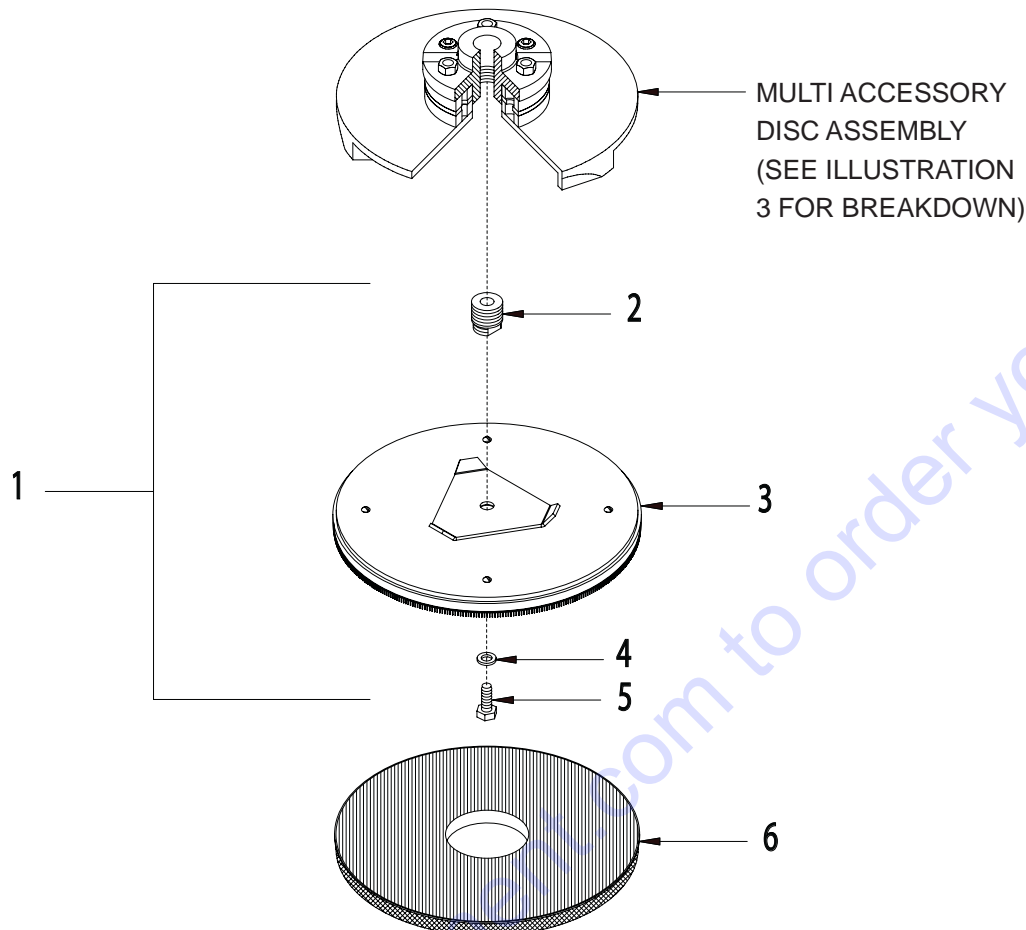


ILLUSTRATION 5 : STRIP-SERT™ ACCESSORY



ITEM#	PART#	DESCRIPTION	QTY.
1		STRIP-SERT ASSEMBLY	3
	12400	ASSY. WITH PRO TUNGSERT (ITEMS 2-9)	
	12401	ASSY. W/O PRO TUNGSERT, ITEM 6	
2	12405	SCREW, SKT.HD.CAP 1/2-13 X 3.5,GR.8	1
3	12404	TUNGSERT HLDR, STRIP-SERT(RE D BOX)	1
4	11573	SCREW, SKT. HD. CAP 1/4-20 X 3/4	1
5	11688	WASHER, HI-COLLAR LOCK .26ID X .363	1
6	12402	PRO TUNGSERT, 4 SIDED CARBIDE	1
or	12407	PRO TUNGSERT (PACK OF 6 INCLUDING: SIX OF ITEMS 4, 5, & 6 AND ONE OF ITEM 11)	
7	12403	TUNGSERT BLOCK, STRIP-SERT	1
8	12406	SPRING, COMP. .765"OD X 1.25"FL	1
9	10155	NUT, HEX NYLON LOCK 1/2-13	1
10	12160	WEDGE CG225, HARDWOOD	1
11	12413	WRENCH, HEX L-KEY 3/16", SHORT-ARM	1

ILLUSTRATION 6 : OPTIONAL PAD DRIVER DISC ASSEMBLY



ITEM #	PART#	DESCRIPTION	QTY.
1	76040	PAD DRIVER DISC ASSEMBLY (INCLUDES ITEMS 2-5)	1
2	76042	HUB STUD, PAD DRIVER	1
3	76041	DISC ONLY 11", PAD DRIVER	1
4	10312	WASHER, FLAT 1/2	1
5	10304	SCREW, CAP 1/2-20 X 1	1
6	13013	SILABIDE PAD, 11" MEDIUM	2

OTHER ACCESSORIES:

GRINDING STONES, SCARIFIER ASSEMBLIES, WIRE BRUSHES, AND DIAMOND POLISHING DISC ARE ALSO AVAILABLE. REFER TO PRICE LIST CATALOG OR CONTACT DISCOUNT-EQUIPMENT FOR INFORMATION.

PARTS FINDER

**Search Website
by Part Number**



**Search Manual
Library For Parts
Manual & Lookup Part
Numbers – Purchase
or Request Quote**

Search Manuals

Enter your information to help us find the right parts manual for your machine.

* Brand:

* Model:

* Serial:

* Part Number:

SEARCH

**Can't Find Part or
Manual? Request Help
by Manufacturer,
Model & Description**

Parts Order Form

Please fill in the following information to help us find the right part for your machine.

Manufacturer:	<input type="text"/>
Model:	<input type="text"/>
Description:	<input type="text"/>
Part Number:	<input type="text"/>
Quantity:	<input type="text"/>
Notes:	<input type="text"/>

Discount-Equipment.com is your online resource for quality parts & equipment.

Florida: **561-964-4949** Outside Florida TOLL FREE: **877-690-3101**

Need parts?

Click on this link: <http://www.discount-equipment.com/category/5443-parts/> and choose one of the options to help get the right parts and equipment you are looking for. Please have the machine model and serial number available in order to help us get you the correct parts. If you don't find the part on the website or on one of the online manuals, please fill out the request form and one of our experienced staff members will get back to you with a quote for the right part that your machine needs.

We sell worldwide for the brands: Genie, Terex, JLG, MultiQuip, Mikasa, Essick, Whiteman, Mayco, Toro Stone, Diamond Products, Generac Magnum, Airman, Haulotte, Barreto, Power Blanket, Nifty Lift, Atlas Copco, Chicago Pneumatic, Allmand, Miller Curber, Skyjack, Lull, Skytrak, Tsurumi, Husquvarna Target, Stow, Wacker, Sakai, Mi-T-M, Sullair, Basic, Dynapac, MBW, Weber, Bartell, Bennar Newman, Haulotte, Ditch Runner, Menegotti, Morrison, Contec, Buddy, Crown, Edco, Wyco, Bomag, Laymor, EZ Trench, Bil-Jax, F.S. Curtis, Gehl Pavers, Heli, Honda, ICS/PowerGrit, IHI, Partner, Imer, Clipper, MMD, Koshin, Rice, CH&E, General Equipment, Amida, Coleman, NAC, Gradall, Square Shooter, Kent, Stanley, Tamco, Toku, Hatz, Kohler, Robin, Wisconsin, Northrock, Oztec, Toker TK, Rol-Air, APT, Wylie, Ingersoll Rand / Doosan, Innovatech, Con X, Ammann, Mecalac, Makinex, Smith Surface Prep, Small Line, Wanco, Yanmar