

(en) **Parts Manual**  
**MAXI-POWER™ 45**



Go to [Discount-Equipment.com](http://Discount-Equipment.com) to order your parts



[www.discount-equipment.com](http://www.discount-equipment.com)

# PARTS FINDER

**Search Website  
by Part Number**



**Search Manual  
Library For Parts  
Manual & Lookup Part  
Numbers – Purchase  
or Request Quote**

**Search Manuals**

Enter your information to help us find the right parts manual for your machine.

\* Brand:

\* Model:

\* Serial:

\* Part Number:

SEARCH

**Can't Find Part or  
Manual? Request Help  
by Manufacturer,  
Model & Description**

**Parts Order Form**

Please fill in the following information to help us find the right part for your machine.

MANUFACTURER:

MODEL:

DESCRIPTION:

DATE:

TIME:

PHONE:

EMAIL:

ADDRESS:

CITY:

STATE:

ZIP:

SEARCH

Discount-Equipment.com is your online resource for quality parts & equipment.

Florida: **561-964-4949** Outside Florida TOLL FREE: **877-690-3101**

**Need parts?**

Click on this link: <http://www.discount-equipment.com/category/5443-parts/> and choose one of the options to help get the right parts and equipment you are looking for. Please have the machine model and serial number available in order to help us get you the correct parts. If you don't find the part on the website or on one of the online manuals, please fill out the request form and one of our experienced staff members will get back to you with a quote for the right part that your machine needs.

We sell worldwide for the brands: Genie, Terex, JLG, MultiQuip, Mikasa, Essick, Whiteman, Mayco, Toro Stone, Diamond Products, Generac Magnum, Airman, Haulotte, Barreto, Power Blanket, Nifty Lift, Atlas Copco, Chicago Pneumatic, Allmand, Miller Curber, Skyjack, Lull, Skytrak, Tsurumi, Husquvarna Target, Stow, Wacker, Sakai, Mi-T-M, Sullair, Basic, Dynapac, MBW, Weber, Bartell, Bennar Newman, Haulotte, Ditch Runner, Menegotti, Morrison, Contec, Buddy, Crown, Edco, Wyco, Bomag, Laymor, EZ Trench, Bil-Jax, F.S. Curtis, Gehl Pavers, Heli, Honda, ICS/PowerGrit, IHI, Partner, Imer, Clipper, MMD, Koshin, Rice, CH&E, General Equipment, Amida, Coleman, NAC, Gradall, Square Shooter, Kent, Stanley, Tamco, Toku, Hatz, Kohler, Robin, Wisconsin, Northrock, Oztec, Toker TK, Rol-Air, APT, Wylie, Ingersoll Rand / Doosan, Innovatech, Con X, Ammann, Mecalac, Makinex, Smith Surface Prep, Small Line, Wanco, Yanmar

## TABLE OF CONTENTS

### 1.0 TRAILER PARTS GROUP

Trailer Axle, Jack, and Coupler .....	(1.1)
Front and Top Enclosure Panels .....	(1.2)
Left Enclosure Panels and Doors .....	(1.3)
Right Enclosure Panels and Doors .....	(1.4)
Rear Enclosure Panels .....	(1.5)
Spare Tire Group .....	(1.6)

### 2.0 ENGINE AND GENERATOR GROUP

Isuzu 4LE2X Engine Group .....	(2.1)
Engine Air Intake Group .....	(2.2)
Engine Exhaust Group .....	(2.3)
Engine Cooling Group .....	(2.4)
Fuel Tank and Fuel Lines .....	(2.5)
Generator Assembly Group .....	(2.6)

### 3.0 ELECTRICAL GROUP

Control Box Group .....	(3.1)
Electrical Outlet Box Group .....	(3.2)
Battery Cables Group .....	(3.3)
Tail Lights and Tail Light Harness .....	(3.4)
Cam Lock Group .....	(3.5)
Battery Charger, Battery Heater, and Block Heater .....	(3.6)
Battery Disconnect .....	(3.7)

# Maxi-Power™ 45 T4F

## TABLE OF CONTENTS

### 4.0 DECALS

Right and Top Side Enclosure Decals .....	(4.1)
Left and Front Side Enclosure Decals .....	(4.2)
Rear Side Enclosure and Control Box Decals .....	(4.3)
Electrical Decals .....	(4.4)
Cam Lock and Arctic Package Decals .....	(4.5)

Go to [Discount-Equipment.com](http://Discount-Equipment.com) to order your parts

## 1.1 - Trailer Axle, Jack, and Coupler

**To Be Determined**

000000\_A

# Maxi-Power™ 45 T4F

SN 23-000001 and UP

## 1.1 - Trailer Axle, Jack, and Coupler

Item	Allmand No.	Part Description	Qty.
1	***	to be determined	
2	***		
3	***		
4	***		
5	***		
6	***		
7	***		
8	***		
9	***		
10	***		

NS - Not Shown

\*\*\* - Contact Allmand for more information.

Go to Discount-Equipment.com to order your parts

## 1.2 - Front and Top Enclosure Panels

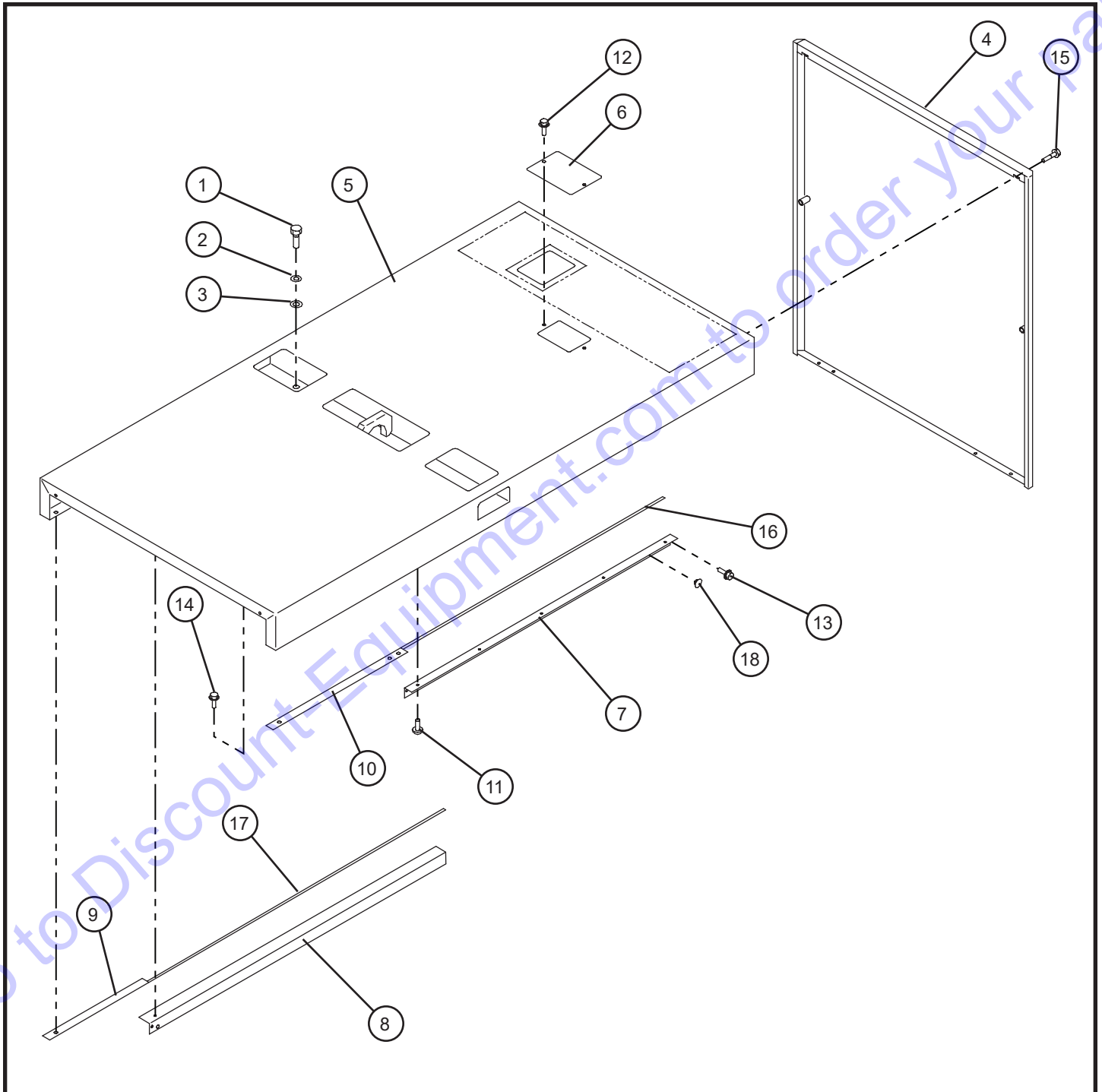

# Maxi-Power™ 45 T4F

SN 23-000001 and UP

## 1.2 - Front and Top Enclosure Panels

Item	Allmand No.	Part Description	Qty.
1	***	BOLT	12
2	***	SPRING WASHER	4
3	***	PLAIN WASHER	4
4	***	COVER	1
5	***	TOP COVER	1
6	110472	COVER	1
7	***	BRACKET	1
8	***	BRACKET	1
9	***	CUSHION RUBBER	1
10	***	CUSHION RUBBER	1
11	***	SCREW	14
12	***	BOLT, W/W	2
13	110514	FLANGE BOLT	20
14	110515	FLANGE BOLT	21
15	***	BOLT, W/W	8
16	***	SEAL RUBBER	1
17	***	SEAL RUBBER	1
18	***	GROMMET	8
NS	***	SIDE PANELS URETHANE FOAM KIT	1

NS - Not Shown

\*\*\* - Contact Allmand for more information.



## 1.3 - Left Enclosure Panels and Doors

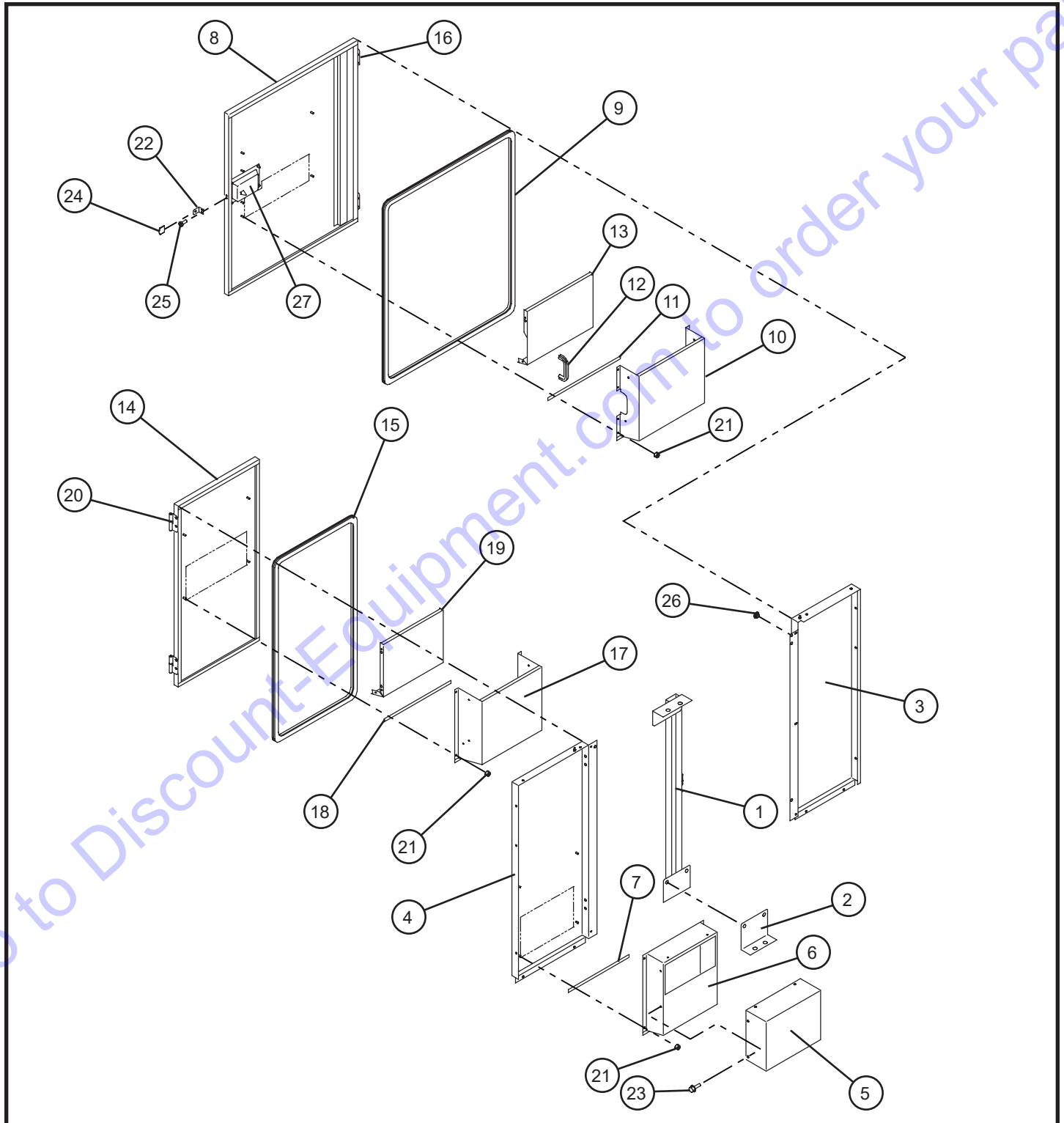

# Maxi-Power™ 45 T4F

SN 23-000001 and UP

## 1.3 - Left Enclosure Panels and Doors

Item	Allmand No.	Part Description	Qty.
1	***	LIFTING BAIL	2
2	***	STAY	2
3	***	COVER	1
4	***	COVER	1
5	***	DUCT	1
6	***	DUCT	1
7	***	SEAL RUBBER	1
8	***	DOOR	1
9	***	SEAL RUBBER	2
10	***	DUCT	1
11	***	SEAL RUBBER	1
12	***	SEAL RUBBER	1
13	***	DUCT	1
14	***	DOOR	1
15	***	SEAL RUBBER	1
16	114303	HINGE	6
17	***	DUCT	1
18	***	SEAL RUBBER	1
19	***	DUCT	1
20	114302	HINGE	8
21	***	HEXAGON FLANGE NUT	46
22	***	BRACKET	2
23	110514	FLANGE BOLT	20
24	***	SCREW	4
25	***	CAP	3
26	***	GROMMET	8
27	110499	LATCH ASSEMBLY	3
	***	CUSHION RUBBER	3
NS	***	SIDE PANELS URETHANE FOAM KIT	1
NS	***	DOORS URETHANE FOAME KIT	1
NS	112827	KEY	1

NS - Not Shown

\*\*\* - Contact Allmand for more information.

## 1.4 - Right Enclosure Panels and Doors

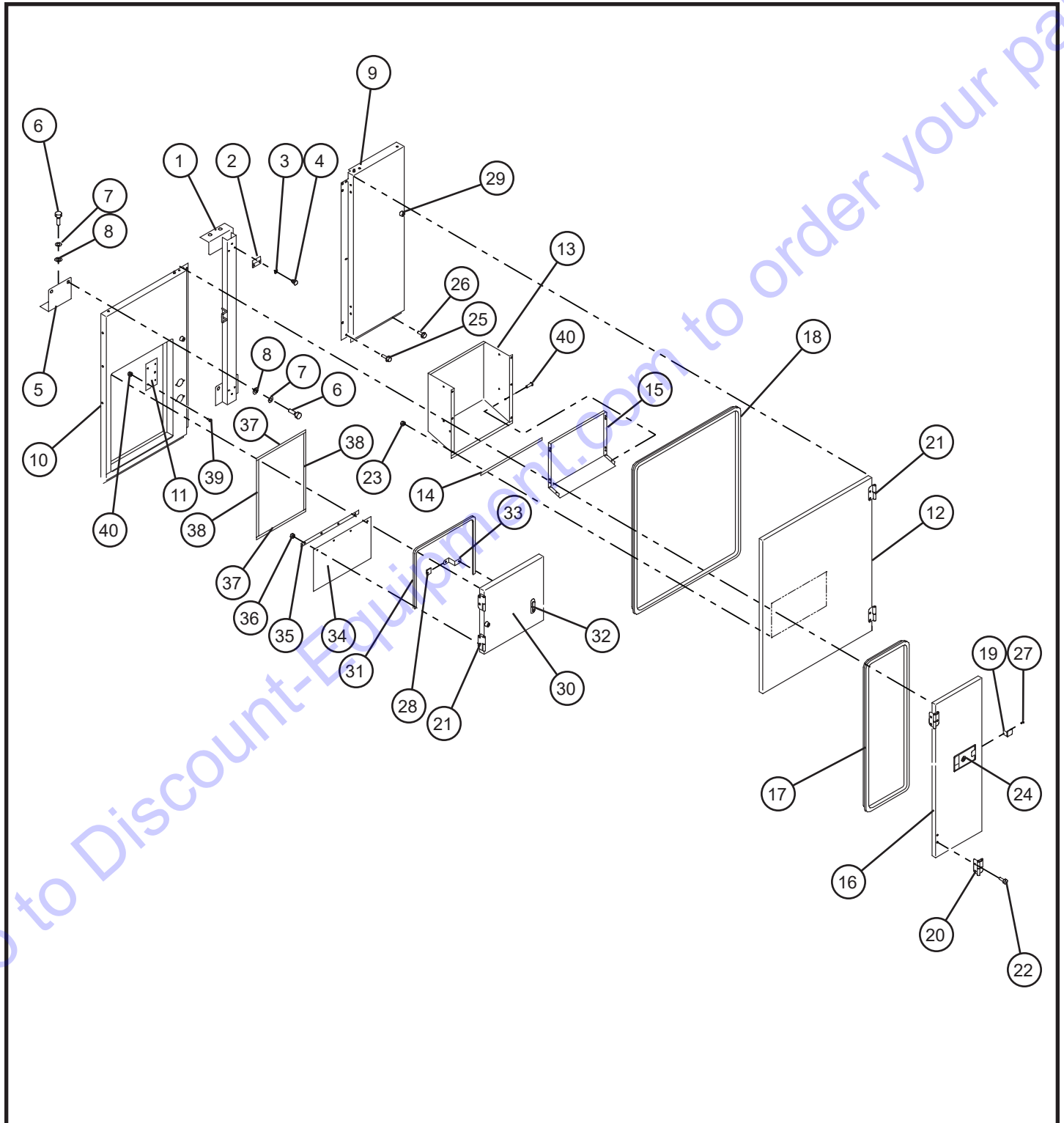

# Maxi-Power™ 45 T4F

SN 23-000001 and UP

## 1.4 - Right Enclosure Panels and Doors

Item	Allmand No.	Part Description	Qty.
1	***	LIFTING BAIL	2
2	***	CUSHION RUBBER	4
3	***	PLAIN WASHER	8
4	***	CAP	8
5	***	STAY	2
6	***	BOLT	12
7	***	SPRING WASHER	8
8	***	PLAIN WASHER	8
9	***	COVER	1
10	***	COVER	1
11	110538	COVER	1
12	***	DOOR	1
13	***	DUCT	1
14	***	SEAL RUBBER	1
15	***	DUCT	1
16	***	DOOR	1
17	***	SEAL RUBBER	1
18	***	SEAL RUBBER	2
19	***	BRACKET	2
20	114303	HINGE	6
21	114302	HINGE	8
22	***	BOLT	56
23	***	HEXAGON FLANGE NUT	46
24	110499	LATCH ASSEMBLY	3
	***	CUSHION RUBBER	3
25	110514	FLANGE BOLT	20
26	110515	FLANGE BOLT	21
27	***	SCREW	4
28	***	CAP	3
29	***	RUBBER	7
30	***	DOOR	1
31	***	SEAL RUBBER	1
32	118045	LATCH	1
33	***	PLATE	1
34	***	CUSHION RUBBER	1
35	***	PLATE	1
36	***	LOCKING NUT	4
37	***	SEAL RUBBER	2
38	***	SEAL RUBBER	2
39	***	SCREW	4
40	***	HEXAGON FLANGE NUT	4
41	***	BLIND RIVET	17
NS	***	SIDE PANELS URETHANE FOAM KIT	1
NS	***	DOORS URETHANE FOAME KIT	1
NS	112827	KEY	4

NS - Not Shown

\*\*\* - Contact Allmand for more information.

©2020 Allmand®

## 1.5 - Rear Enclosure Panels

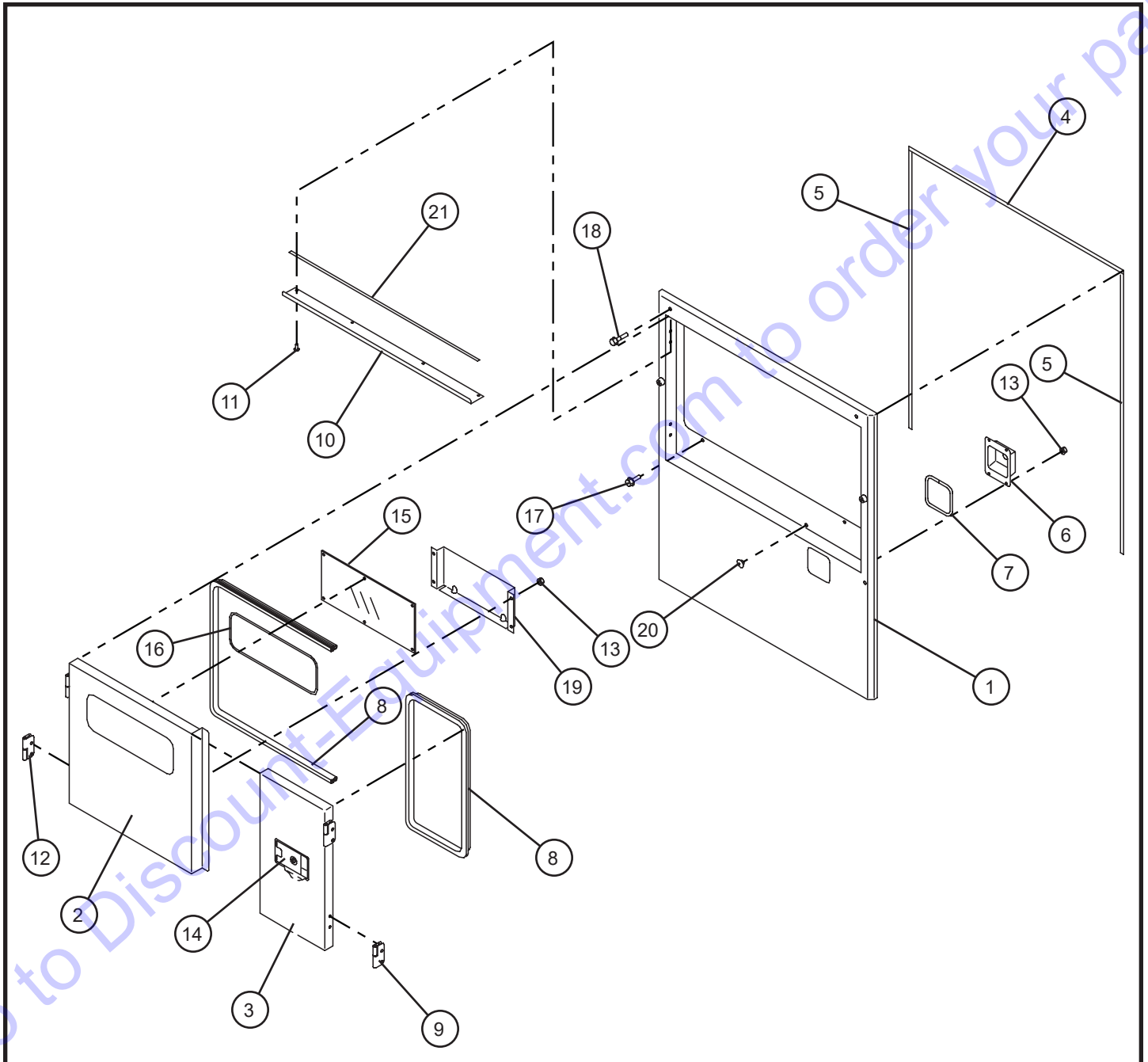

# Maxi-Power™ 45 T4F

SN 23-000001 and UP

## 1.5 - Rear Enclosure Panels

Item	Allmand No.	Part Description	Qty.
1	***	COVER	1
2	***	DOOR	1
3	***	DOOR	1
4	***	SEAL RUBBER	1
5	***	SEAL RUBBER	2
6	110681	COVER	1
7	***	SEAL RUBBER	1
8	***	SEAL RUBBER	2
9	114303	HINGE	6
10	***	BRACKET	1
11	***	SCREW	14
12	114302	HINGE	8
13	***	HEXAGON FLANGE NUT	46
14	110499	LATCH ASSEMBLY	3
	***	CUSHION RUBBER	3
15	110693	WINDOW GLASS	1
16	***	SEAL RUBBER	1
17	110514	FLANGE BOLT	20
18	***	BOLT, W/W	8
19	***	TOOL BOX	1
20	***	GROMMET	8
21	***	SEAL RUBBER	1
NS	***	SIDE PANELS URETHANE FOAM KIT	1
NS	112827	KEY	1

NS - Not Shown

\*\*\* - Contact Allmand for more information.

## 1.6 - Spare Tire Group

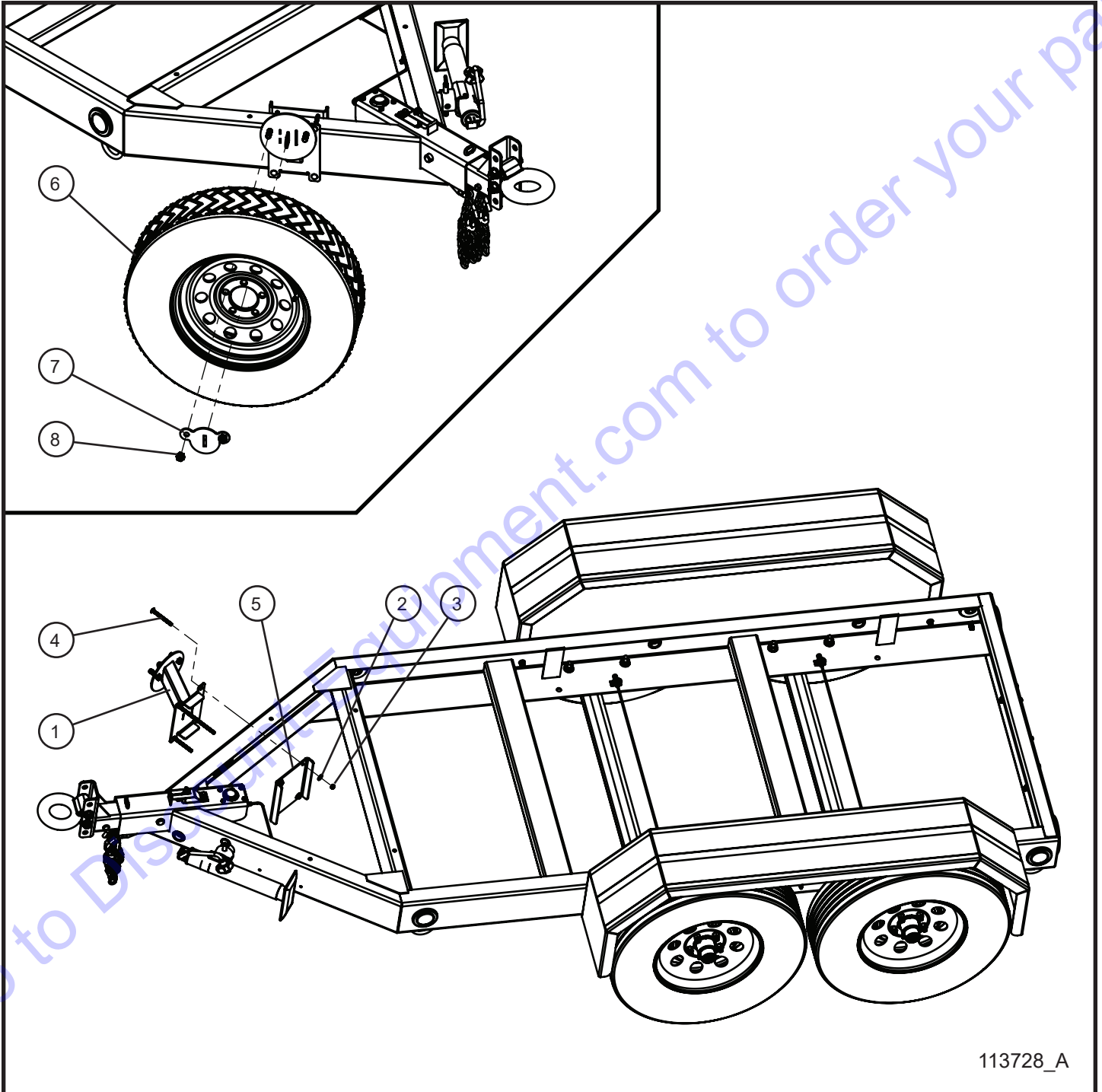

113728\_A

# Maxi-Power™ 45 T4F

SN 23-000001 and UP

## 1.6 - Spare Tire Group

Item	Allmand No.	Part Description	Qty.
1	113726	SPARE TIRE MOUNT WELDMENT MP 40-65	1
2	047010	5/16 FLAT WASHER	4
3	044033	5/16-18 NYLOCK HEX NUT	4
4	053027	5/16-18 x 3.5 CARRIAGE BOLT	4
5	113723P	SPARE TIRE CLAMP PLATE	1
6	113444	WHEEL W/ TIRE ASSEMBLY, 2150 LB CAPACITY	1
7	113724P	SPARE TIRE LOCK PLATE	1
8	044048	1/2-13 NYLOCK HEX NUT	2

NS - Not Shown

\*\*\* - Contact Allmand for more information.

Go to Discount-Equipment.com to order your parts



## 2.1 - Isuzu 4LE2X Engine Group

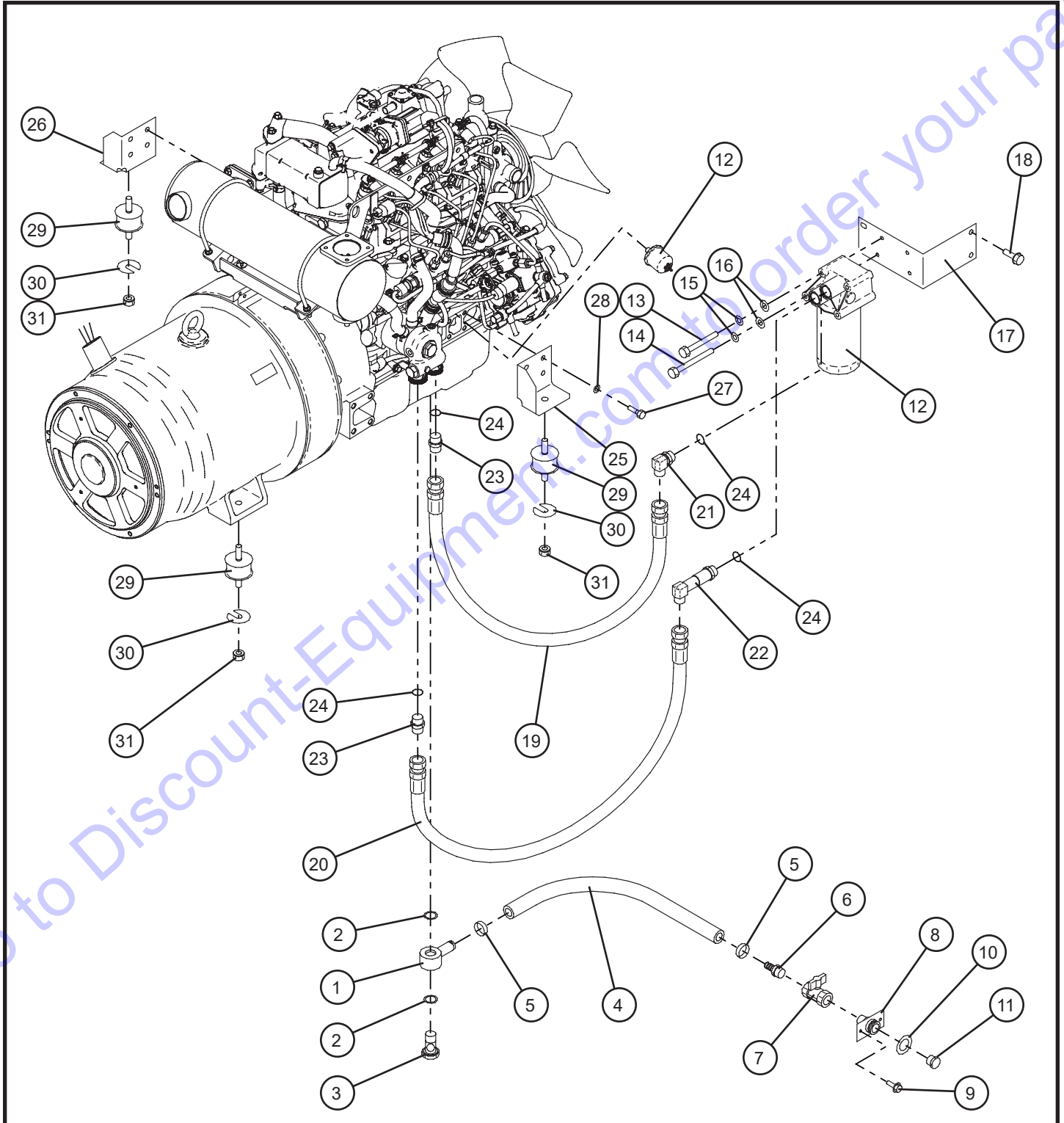

# Maxi-Power™ 45 T4F

SN 23-000001 and UP

## 2.1 - Isuzu 4LE2X Engine Group

Item	Allmand No.	Part Description	Qty.
1	110521	RING CONNECTOR	1
2	110522	GASKET	2
3	110523	NIPPLE	1
4	***	HOSE	1
5	***	HOSE CLIP	2
6	***	JOINT	1
7	110856	VALVE	1
8	***	JOINT	1
9	110514	FLANGE BOLT	2
10	***	CUSHION RUBBER	1
11	***	PLUG	1
12	***	FILTER ASSEMBLY	1
	110634	FILTER CARTRIDGE	1
13	***	BOLT	2
14	***	BOLT	2
15	***	SPRING WASHER	4
16	***	PLAIN WASHER	4
17	***	BRACKET	1
18	110515	FLANGE BOLT	4
19	***	HOSE	1
20	***	HOSE	1
21	***	NIPPLE ELBOW	1
22	***	NIPPLE	1
23	***	NIPPLE	2
24	***	O-RING	4
25	***	BRACKET	1
26	***	BRACKET	1
27	***	BOLT	8
28	***	SPRING WASHER	8
29	110757	VIBRATION ISOLATOR ASSEMBLY	4
30	***	SHIM	1
31	***	NUT, W/W	8
32	110487	OIL PRESSURE SENDER	1
NS	111647	BELT, COOLING FAN	
NS	110671	THERMO SWITCH	1

NS - Not Shown

\*\*\* - Contact Allmand for more information.

©2020 Allmand®

## 2.2 - Engine Intake Group

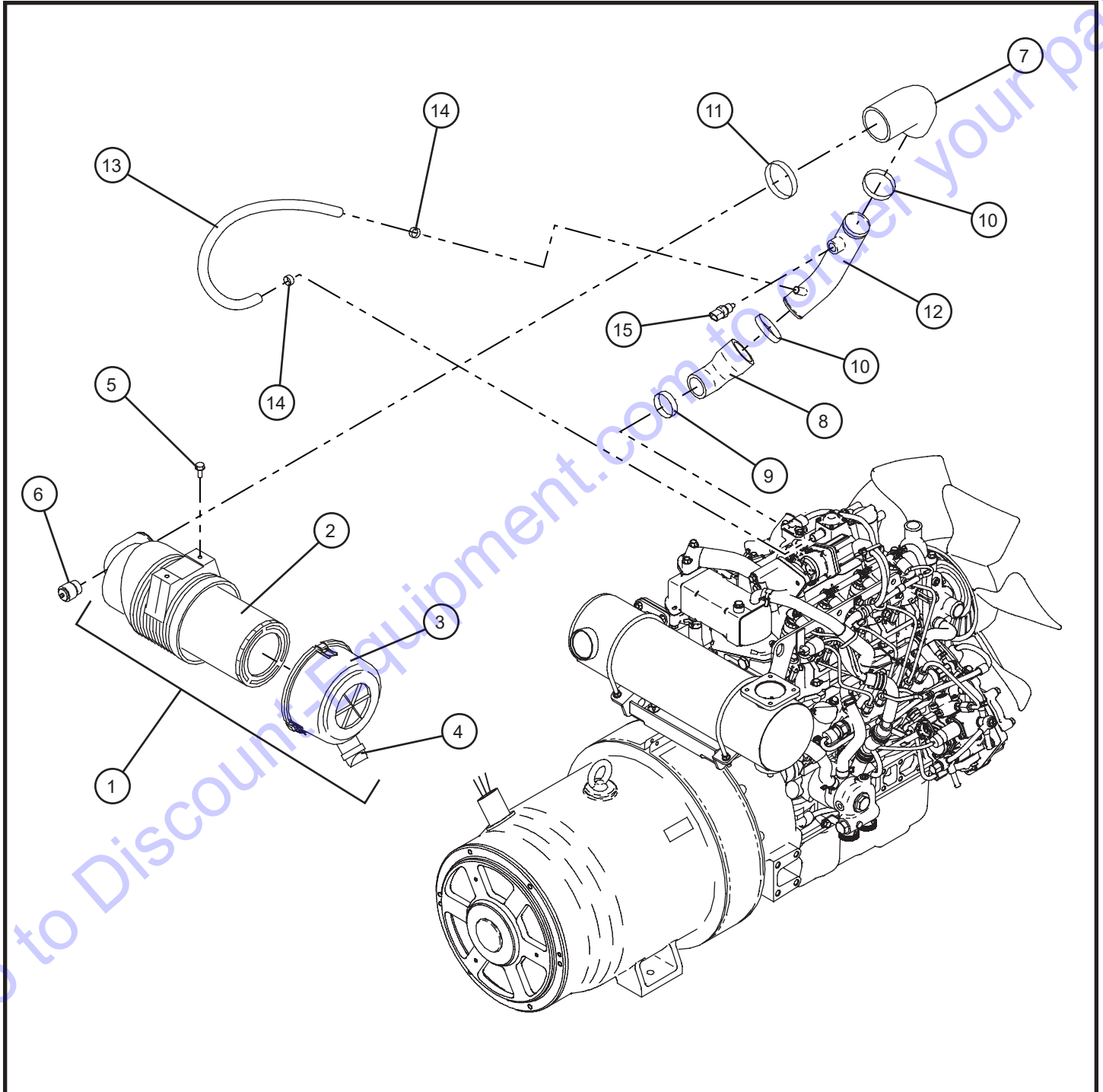

# Maxi-Power™ 45 T4F

SN 23-000001 and UP

## 2.2 - Engine Intake Group

Item	Allmand No.	Part Description	Qty.
1	112970	AIR FILTER ASSEMBLY	1
2	110634	ELEMENT	1
3	***	CUP	1
4	113049	VACUATOR VALVE	1
5	***	FLANGE BOLT	2
6	110637	FILTER, SERVICE INDICATOR	1
7	***	HOSE	1
8	***	HOSE	1
9	***	HOSE CLIP	1
10	***	HOSE CLIP	2
11	***	HOSE CLIP	1
12	***	PIPE	1
13	***	HOSE	1
14	***	HOSE CLIP	2
15	110480	THERMO SENSOR	1

NS - Not Shown

\*\*\* - Contact Allmand for more information.

## 2.3 - Engine Exhaust Group

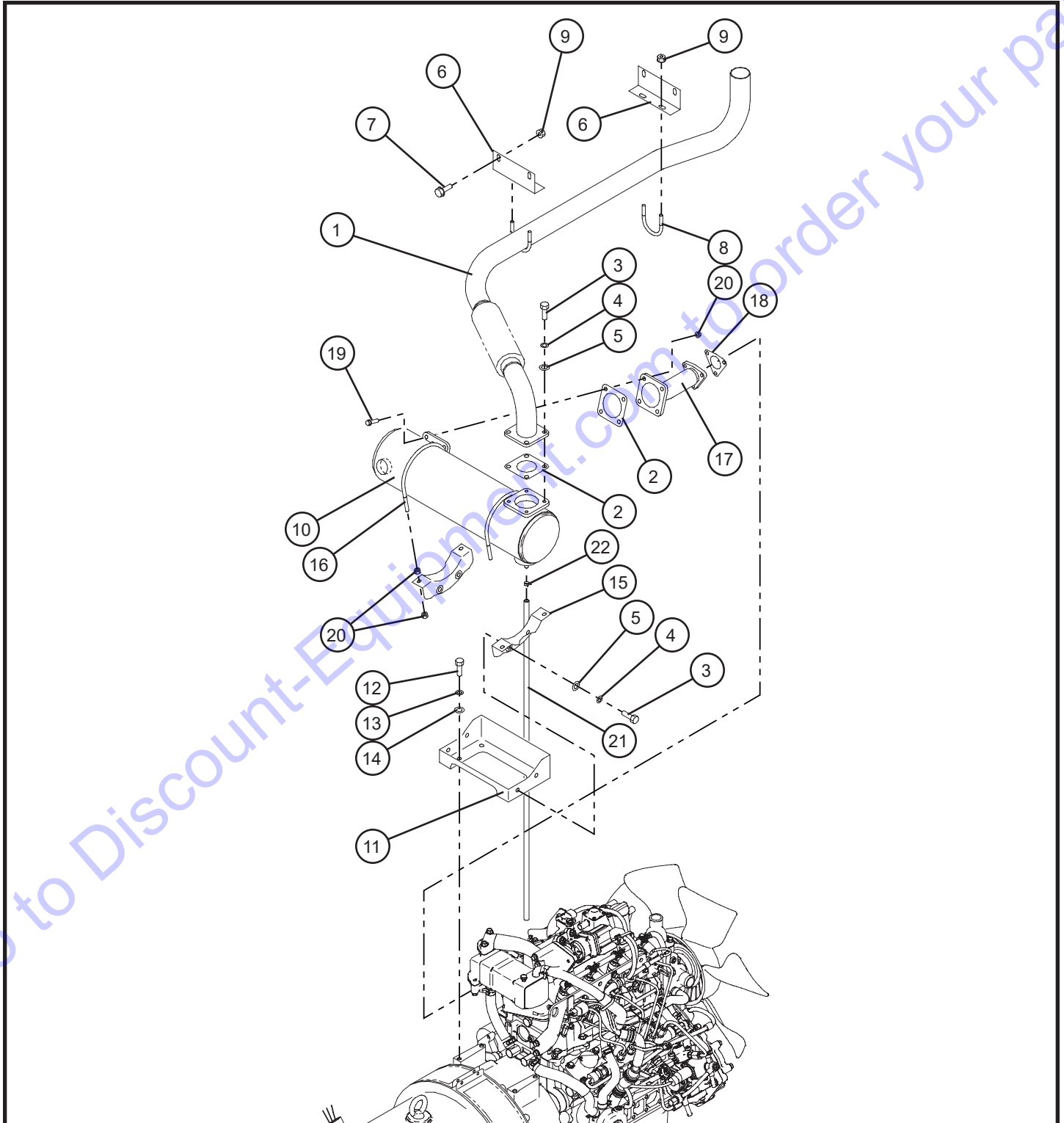

# Maxi-Power™ 45 T4F

SN 23-000001 and UP

## 2.3 - Engine Exhaust Group

Item	Allmand No.	Part Description	Qty.
1	***	PIPE, EXHAUST	1
2	***	GASKET	2
3	***	BOLT	8
4	***	SPRING WASHER	8
5	***	PLAIN WASHER	8
6	***	BRACKET	2
7	110515	FLANGE BOLT	2
8	***	U-BOLT	2
9	***	HEXAGON FLANGE NUT	6
10	***	EXHAUST FILTER	1
11	***	BRACKET	1
12	***	BOLT	4
13	***	SPRING WASHER	4
14	***	PLAIN WASHER	4
15	***	BRACKET	2
16	***	U-BOLT	2
17	***	PIPE, EXHAUST	1
18	***	GASKET	1
19	***	BOLT	4
20	***	HEXAGON FLANGE NUT	15
21	***	PIPE	1
22	***	HOSE CLIP	1

NS - Not Shown

\*\*\* - Contact Allmand for more information.

## 2.4 - Engine Cooling Group

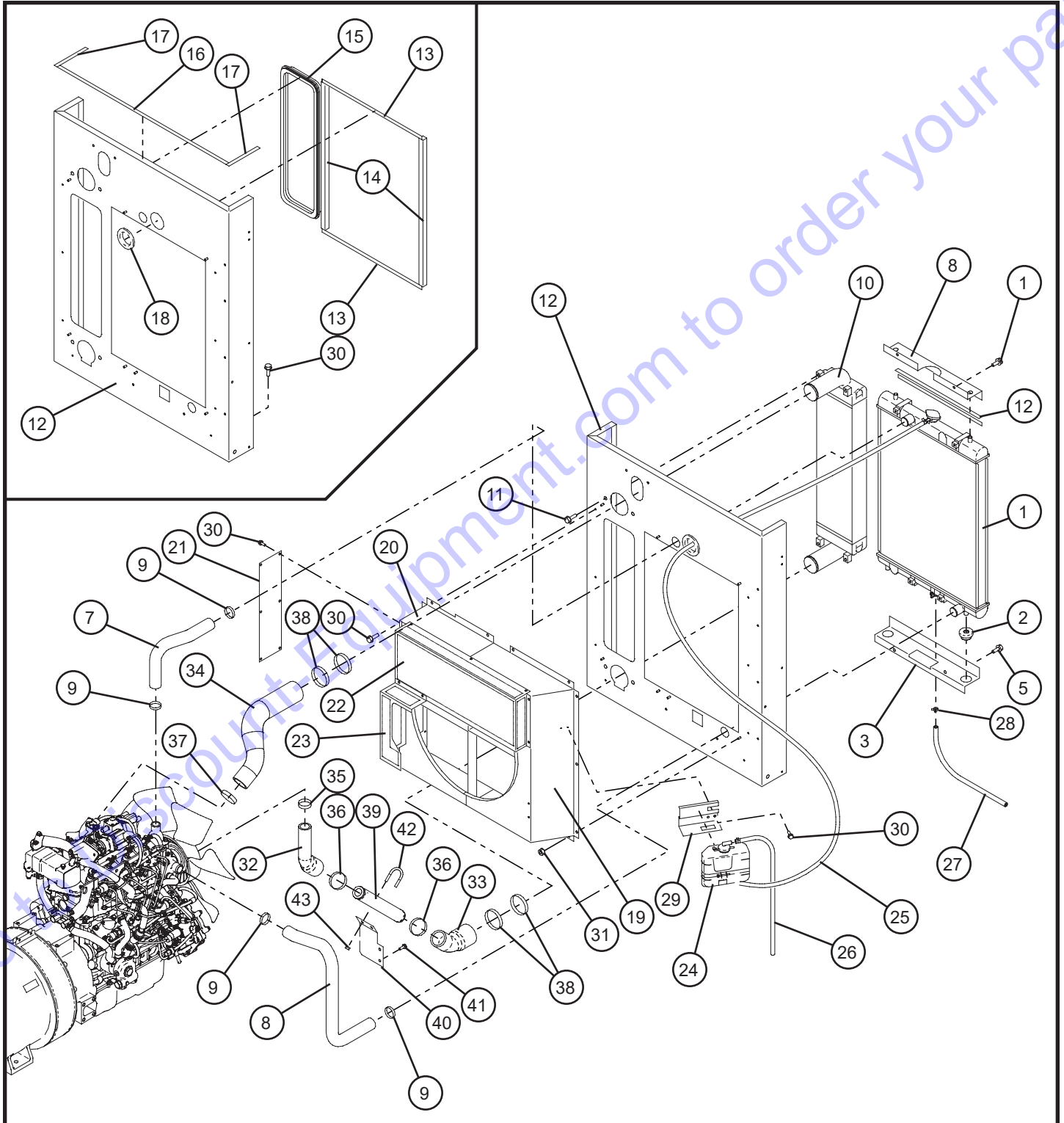

# Maxi-Power™ 45 T4F

SN 23-000001 and UP

## 2.4 - Engine Cooling Group

Item	Allmand No.	Part Description	Qty.
1	111715	RADIATOR	1
	110565	CAP	1
	110508	VALVE	1
2	112855	RUBBER	2
3	***	BRACKET	1
4	***	BRACKET	1
5	110515	FLANGE BOLT	4
6	***	SEAL RUBBER	2
7	***	HOSE	1
8	***	HOSE	1
9	***	HOSE CLIP	4
10	***	INTERCOOLER	1
11	***	FLANGE BOLT	4
12	***	COVER	1
13	***	SEAL RUBBER	2
14	***	SEAL RUBBER	2
15	***	SEAL RUBBER	1
16	***	SEAL RUBBER	1
17	***	SEAL RUBBER	2
18	***	GROMMET	1
19	***	SHROUD, FAN	1
20	***	SHROUD, FAN	1
21	***	PLATE	1
22	***	GUARD, FAN	1
23	***	GUARD, FAN	1
24	110516	RESERVE TANK ASSEMBLY	1
	110517	HOSE CLIP	1
25	110707	HOSE	1
26	110519	HOSE	1
27	***	HOSE	1
28	110520	HOSE CLIP	4
29	110518	BRACKET	1
30	110514	FLANGE BOLT	30
31	***	HEXAGON FLANGE NUT	8
32	***	HOSE	1
33	***	HOSE	1
34	***	HOSE	1
35	***	HOSE CLIP	1
36	***	HOSE CLIP	2
37	***	HOSE CLIP	1
38	***	HOSE CLIP	4
39	***	PIPE	1
40	***	BRACKET	1
41	110515	FLANGE BOLT	2
42	***	U-BOLT	1
43	***	HEXAGON FLANGE NUT	2

NS - Not Shown

\*\*\* - Contact Allmand for more information.

©2020 Allmand®



# PARTS FINDER

**Search Website  
by Part Number**



**Search Manual  
Library For Parts  
Manual & Lookup Part  
Numbers – Purchase  
or Request Quote**

**Search Manuals**

Enter your information to help us find the right parts manual for your machine.

\* Brand:

\* Model:

\* Serial:

\* Part Number:

SEARCH

**Can't Find Part or  
Manual? Request Help  
by Manufacturer,  
Model & Description**

**Parts Order Form**

Please fill in the following information to help us find the right part for your machine.

Manufacturer:	<input type="text"/>
Model:	<input type="text"/>
Description:	<input type="text"/>
Part Number:	<input type="text"/>
Quantity:	<input type="text"/>
Notes:	<input type="text"/>

Submit

Discount-Equipment.com is your online resource for quality parts & equipment.

Florida: **561-964-4949** Outside Florida TOLL FREE: **877-690-3101**

**Need parts?**

Click on this link: <http://www.discount-equipment.com/category/5443-parts/> and choose one of the options to help get the right parts and equipment you are looking for. Please have the machine model and serial number available in order to help us get you the correct parts. If you don't find the part on the website or on one of the online manuals, please fill out the request form and one of our experienced staff members will get back to you with a quote for the right part that your machine needs.

We sell worldwide for the brands: Genie, Terex, JLG, MultiQuip, Mikasa, Essick, Whiteman, Mayco, Toro Stone, Diamond Products, Generac Magnum, Airman, Haulotte, Barreto, Power Blanket, Nifty Lift, Atlas Copco, Chicago Pneumatic, Allmand, Miller Curber, Skyjack, Lull, Skytrak, Tsurumi, Husquvarna Target, Stow, Wacker, Sakai, Mi-T-M, Sullair, Basic, Dynapac, MBW, Weber, Bartell, Bennar Newman, Haulotte, Ditch Runner, Menegotti, Morrison, Contec, Buddy, Crown, Edco, Wyco, Bomag, Laymor, EZ Trench, Bil-Jax, F.S. Curtis, Gehl Pavers, Heli, Honda, ICS/PowerGrit, IHI, Partner, Imer, Clipper, MMD, Koshin, Rice, CH&E, General Equipment, Amida, Coleman, NAC, Gradall, Square Shooter, Kent, Stanley, Tamco, Toku, Hatz, Kohler, Robin, Wisconsin, Northrock, Oztec, Toker TK, Rol-Air, APT, Wylie, Ingersoll Rand / Doosan, Innovatech, Con X, Ammann, Mecalac, Makinex, Smith Surface Prep, Small Line, Wanco, Yanmar

## 2.5 - Fuel Tank and Fuel Lines

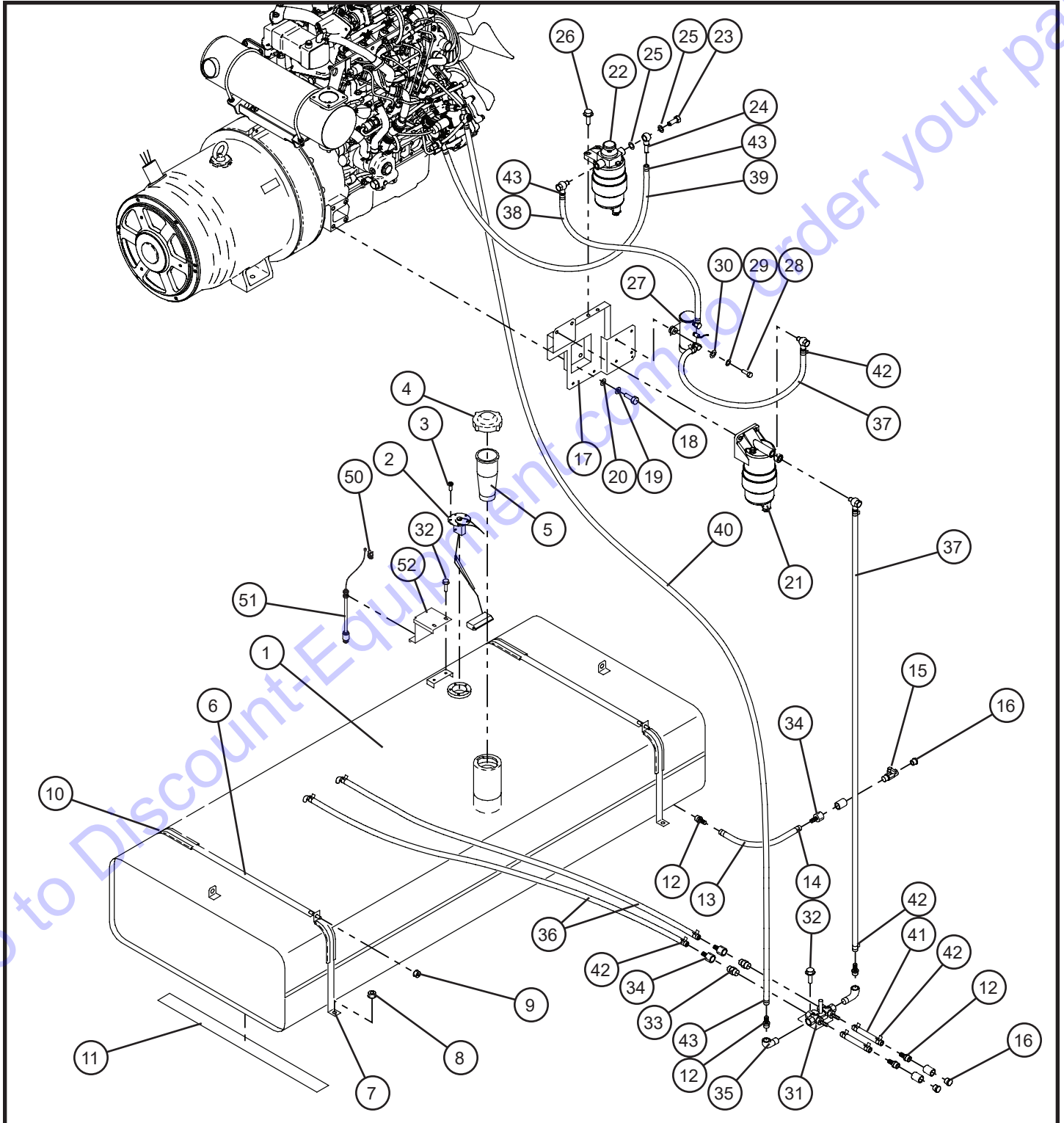

# Maxi-Power™ 45 T4F

SN 23-000001 and UP

## 2.5 - Fuel Tank and Fuel Lines

Item	Allmand No.	Part Description	Qty.
1	***	FUEL TANK	1
2	110688	SENDING UNIT	1
3	***	SCREW W/W	5
4	110495	CAP	1
5	110496	STRAINER	1
6	***	BELT	2
7	***	BELT	2
8	***	HEXAGON FLANGE NUT	4
9	***	HEXAGON FLANGE NUT	2
10	***	CUSHION RUBBER	4
11	***	CUSHION RUBBER	2
12	***	JOINT	5
13	***	HOSE	1
14	***	HOSE CLIP	2
15	***	AIR VALVE	1
16	***	PLUG	3
17	***	BRACKET	1
18	***	BOLT	3
19	***	SPRING WASHER	3
20	***	PLAIN WASHER	3
21	***	FILTER ASSEMBLY (PRE)	1
	111648	FILTER ELEMENT	1
22	***	FILTER ASSEMBLY (MAIN)	1
	112896	FILTER ELEMENT	1
23	***	NIPPLE	4
24	***	RING CONNECTOR	4
25	***	GASKET	8
26	***	FLANGE BOLT	4
27	***	FUEL PUMP	1
28	***	BOLT	2
29	***	SPRING WASHER	2
30	***	PLAIN WASHER	2
31	110502	STOP VALVE	1
32	110514	FLANGE BOLT	2
33	***	NIPPLE	2
34	***	JOINT	3
35	***	ELBOW	2
36	***	HOSE	2
37	***	HOSE	2
38	***	HOSE	1
39	***	HOSE	1
40	***	HOSE	1
41	***	HOSE	2
42	***	HOSE CLIP	12
43	***	HOSE CLIP	6
44	110489	LEVEL SWITCH	1
45	***	BRACKET	1
46	***	CLIP	1

NS - Not Shown

\*\*\* - Contact Allmand for more information.

©2020 Allmand®

## 2.6 - Generator Assembly Group

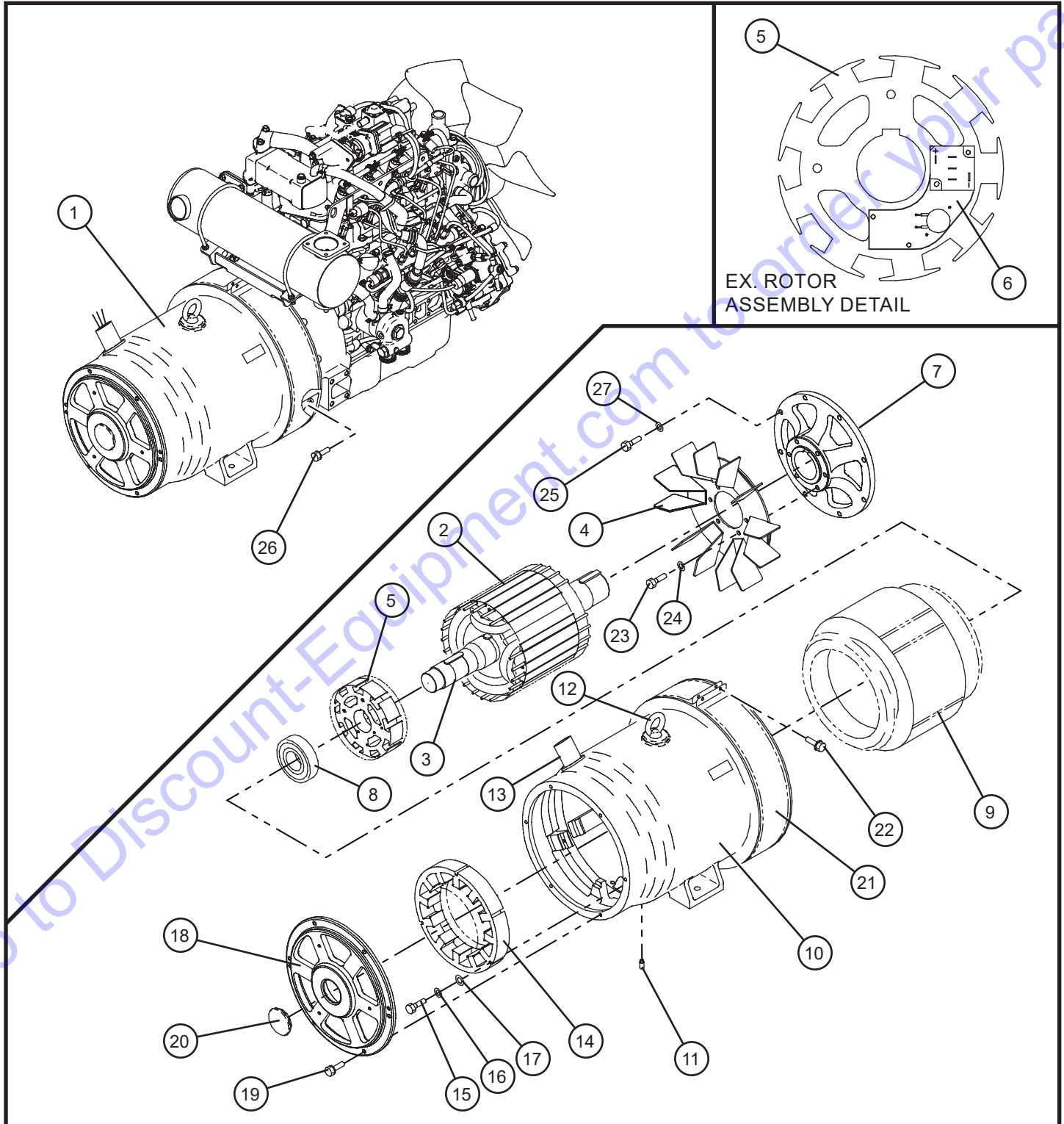

# Maxi-Power™ 45 T4F

SN 23-000001 and UP

## 2.6 - Generator Assembly Group

Item	Allmand No.	Part Description	Qty.
1	***	GENERATOR	1
2	***	A.C.G. ROTOR ASSEMBLY	1
3	***	SHAFT	1
	***	KEY	1
	***	KEY	1
	***	KEY	1
4	***	FAN	1
5	***	EX. ROTOR ASSEMBLY	1
6	110526	WIRING BOARD	1
7	***	COUPLING, DRIVE	1
8	***	BEARING	1
9	***	A.C.G. STATOR ASSEMBLY	1
10	***	CASING	1
11	***	SET SCREW	2
12	***	EYE BOLT	1
13	***	GROMMET	1
14	***	EX. STATOR ASSEMBLY	1
15	***	BOLT	3
16	***	SPRING WASHER	3
17	***	PLAIN WASHER	3
18	***	CASING	1
19	***	BOLT, W/W	6
20	***	GROMMET	1
21	***	COVER	1
22	***	BOLT, W/W	2
23	***	BOLT	6
24	***	SPRING WASHER	6
25	***	BOLT	8
26	***	BOLT, W/W	12
27	***	SPRING WASHER	8

NS - Not Shown

\*\*\* - Contact Allmand for more information.

## 3.1 - Control Box Group

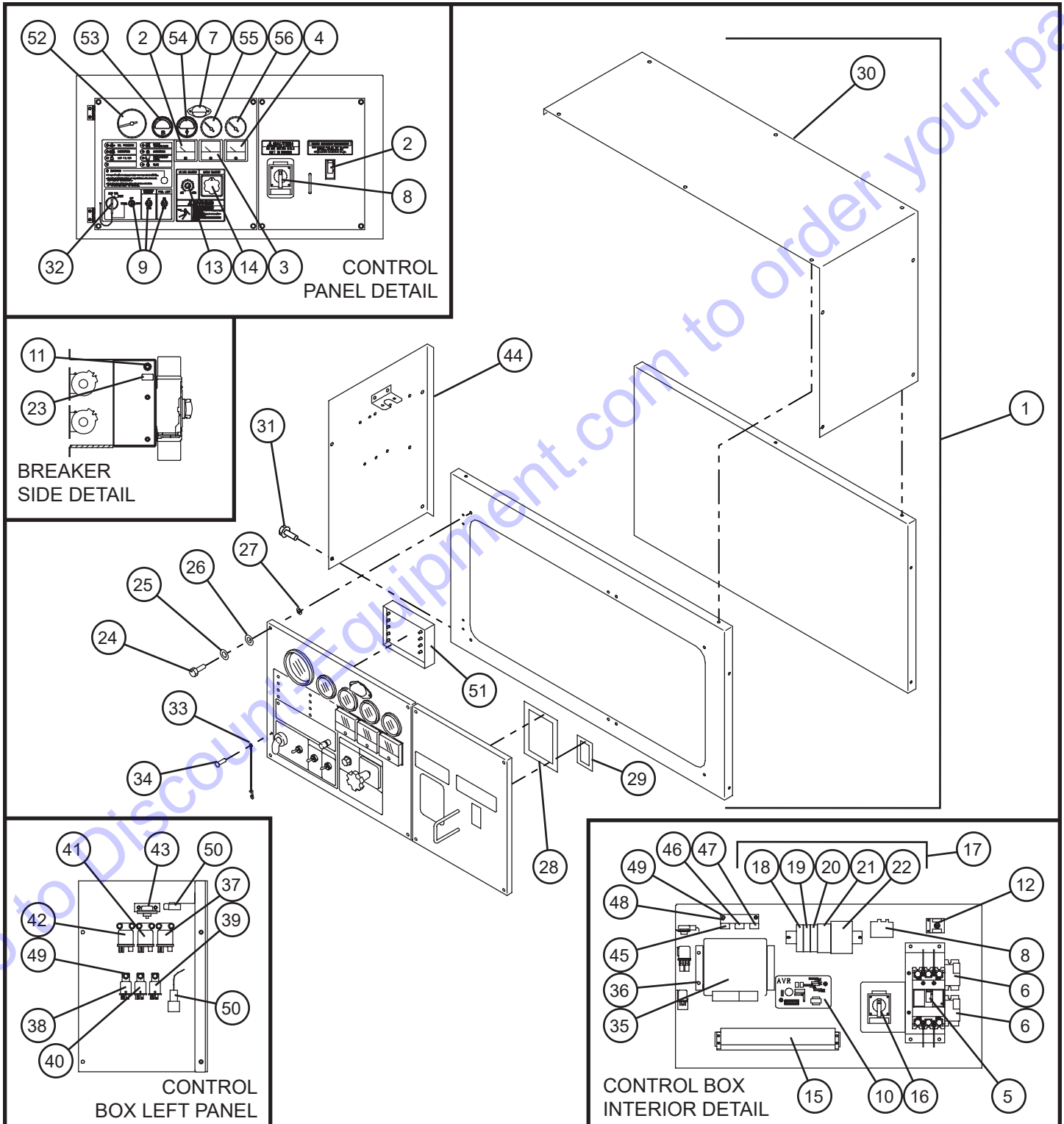



# Maxi-Power™ 45 T4F

SN 23-000001 and UP

## 3.1 - Control Box Group

Item	Allmand No.	Part Description	Qty.
1	***	SWITCH BOARD ASSEMBLY	1
2	110443	VOLTMETER (AC)	1
3	110644	AMMETER (AC)	1
4	110445	FREQUENCY METER	1
5	***	CIRCUIT BREAKER	1
6	110684	CURRENT TRANSFORMER	2
7	110448	ILLUMINATOR	1
8	110929	BULB	1
8	110682	THERMAL RELAY	1
9	110450	SWITCH PANEL ASSEMBLY	1
10	110451	A.V.R. ASSEMBLY	1
11	110452	CIRCUIT BREAKER	1
12	110453	SELECT SWITCH	1
13	110454	CONTROLLER	1
13	***	KNOB	1
14	110455	TRANSFER DEVICE	1
15	110456	TERMINAL PLATE	1
15	118037	PLATE	1
16	***	CHANGE DEVICE, VOLTAGE	1
17	***	CONTROL PANEL	1
18	110459	RELAY	1
19	110460	RELAY	1
20	110461	RELAY	2
21	110462	DC POWER SUPPLY	1
21	***	SURGE ABSORBER	1
22	***	CONTROLLER COMPLETE	1
22	***	CONTROLLER COMPLETE	1
22	110683	SILICON RECTIFIER	2
23	***	PLATE (CP)	1
24	***	BOLT	8
25	***	SPRING WASHER	8
26	***	PLAIN WASHER	8
27	***	WASHER	8
28	***	LINING	1
29	***	LINING	1
30	***	COVER	1
31	110514	FLANGE BOLT	39
32	110471	STARTER SWITCH	1
32	***	KEY	1
33	***	HOOK	1
34	***	BLIND RIVET	1
35	***	CONTROLLER	1
36	***	BRACKET	2
37	110473	RELAY (CHARGE)	1
38	***	RELAY (MAIN)	1
39	***	RELAY (STARTER CUT)	1
40	***	RELAY (FUEL PUMP)	1
41	110477	RELAY (GLOW)	1
42	110478	RELAY (STARTER)	1
42	110479	PRESSURE SWITCH	1
43	***	SCREW	2
43	***	SPRING WASHER	2
43	***	PLAIN WASHER	2
44	***	BRACKET	1
45	110662	FUSE BOX	1
45	110930	FUSE (10A)	1
46	110658	FUSE BOX	1
46	***	FUSE (15A)	1
47	110660	FUSE BOX	1
47	110900	FUSE (20A)	1
48	***	BRACKET	1
49	***	BOLT, W/W	19
50	110714	FUSE BOX (60A)	2
51	110481	CONTROLLER	1
52	110475	TACHOMETER	1
53	110476	GAUGE, FUEL	1
54	110484	THERMOMETER, WATER	1
55	110485	GAUGE, OIL PRESSURE	1
56	110486	AMMETER	1
NS	***	LOCK ASSEMBLY	1
NS	***	KEY	1

NS - Not Shown

\*\*\* - Contact Allmand for more information.

©2020 Allmand®

## 3.2 - Electrical Outlet Box Group

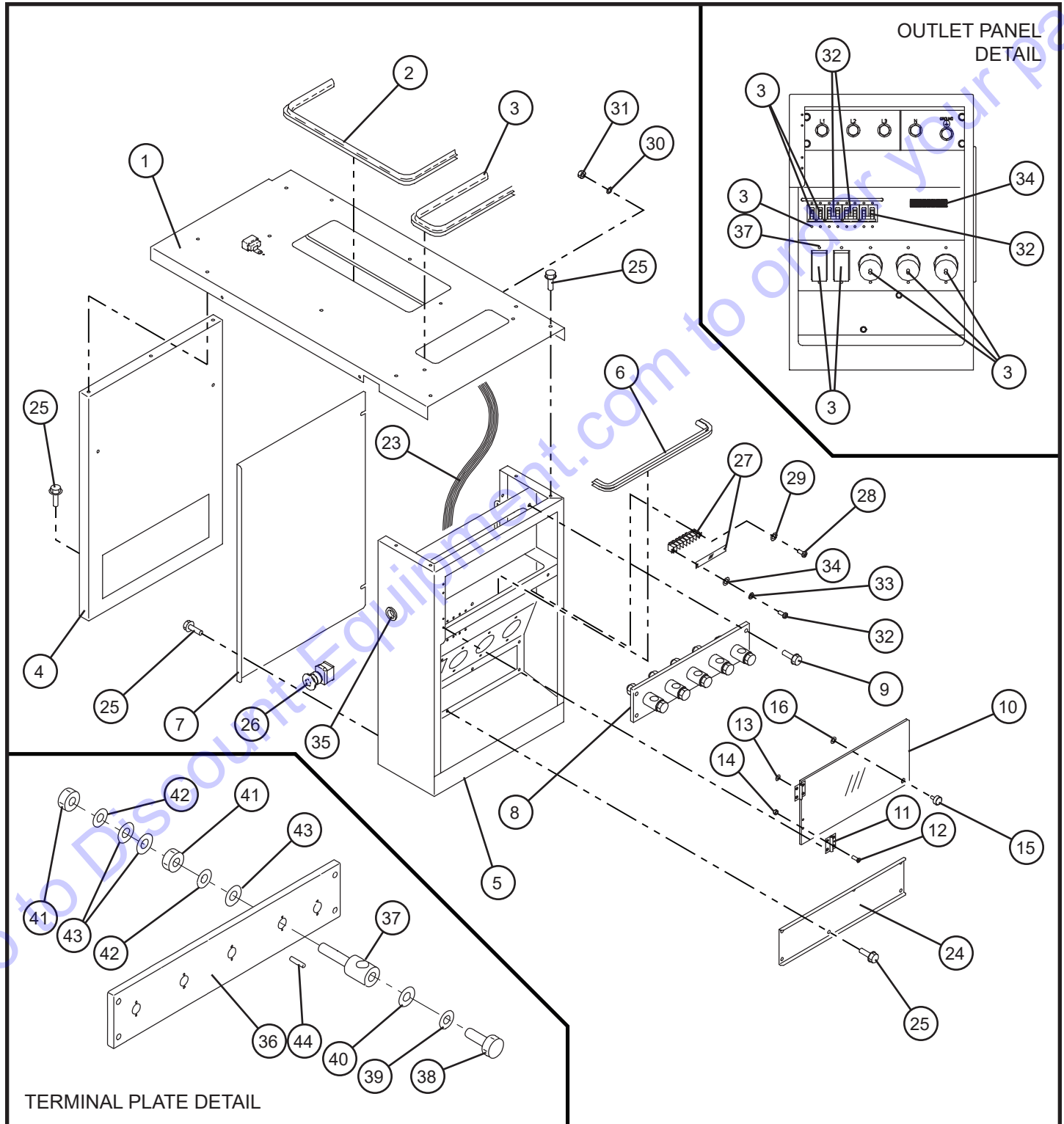



# Maxi-Power™ 45 T4F

SN 23-000001 and UP

## 3.2 - Electrical Outlet Box Group

Item	Allmand No.	Part Description	Qty.
1	***	COVER	1
2	***	SEAL RUBBER	1
3	***	SEAL RUBBER	1
4	***	COVER	1
5	***	BOX	1
6	***	SEAL RUBBER	1
7	***	COVER	1
8	110655	TERMINAL PLATE	1
9	110515	FLANGE BOLT	4
10	***	WINDOW GLASS	1
11	***	HINGE	2
12	***	SCREW	8
13	***	PLAIN WASHER	4
14	***	HEXAGON FLANGE NUT	4
15	***	BOLT	1
16	***	WASHER	1
17	110464	CIRCUIT BREAKER	3
	110465	CIRCUIT BREAKER	3
18	110466	CIRCUIT BREAKER	2
	110467	CIRCUIT BREAKER	2
19	***	SCREW	16
	***	SPRING WASHER	16
	***	PLAIN WASHER	16
20	110468	SOCKET	3
21	110469	SOCKET	2
22	***	SCREW	10
	***	NUT	10
	***	SPRING WASHER	10
	***	PLAIN WASHER	20
23	***	CABLE KIT	1
24	***	COVER	1
25	110514	FLANGE BOLT	39
26	110490	BUTTON SWITCH	1
27	***	TERMINAL PLATE	1
28	***	SCREW	2
29	***	PLAIN WASHER	2
30	***	SPRING WASHER	2
31	***	NUT	2
32	***	SCREW	2
33	***	SPRING WASHER	2
34	***	PLAIN WASHER	2
35	***	GROMMET	2
36	113036	PLATE	1
37	***	BOLT	5
38	112075	BOLT	5
39	113038	SPRING WASHER	5
40	113039	PLAIN WASHER	5
41	112076	NUT	10
42	113040	SPRING WASHER	10
43	113041	PLAIN WASHER	15
44	113042	PIN	10

NS - Not Shown

\*\*\* - Contact Allmand for more information.

©2020 Allmand®

## 3.3 - Battery Cables Group

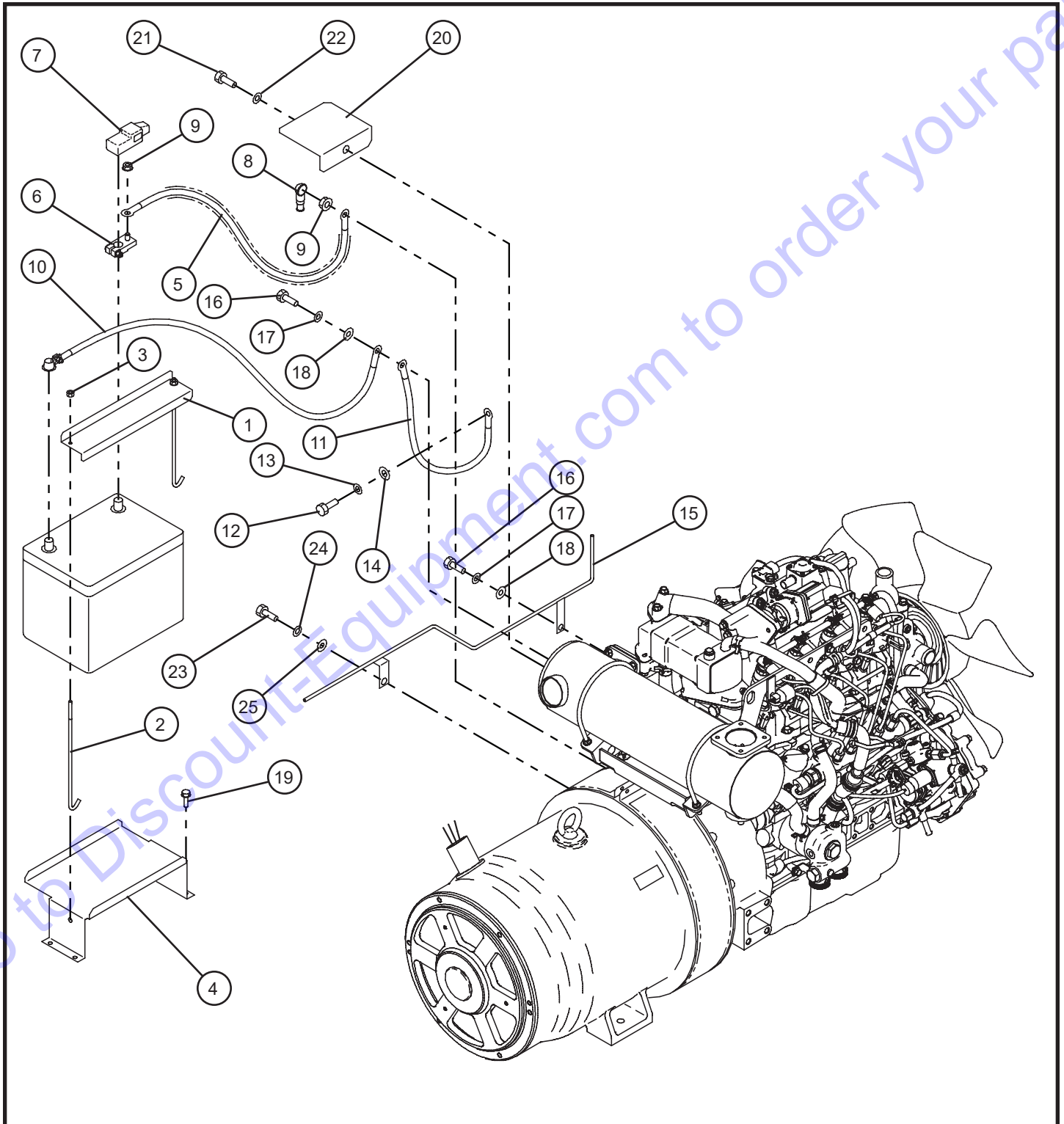

# Maxi-Power™ 45 T4F

SN 23-000001 and UP

## 3.3 - Battery Cables Group

Item	Allmand No.	Part Description	Qty.
1	***	COVER	1
2	***	HOLDER	2
3	***	HEXAGON FLANGE NUT	2
4	***	BATTERY BOX	1
5	***	CABLE	1
	***	CORRUGATED TUBE	1
6	***	TERMINAL	1
7	***	INSULATOR	1
8	***	INSULATOR	1
9	***	HEXAGON FLANGE NUT	2
10	***	CABLE	1
11	***	CABLE	1
12	***	BOLT	1
13	***	SPRING WASHER	1
14	***	PLAIN WASHER	1
15	***	GUIDE	1
16	***	BOLT	2
17	***	SPRING WASHER	2
18	***	PLAIN WASHER	2
19	110514	FLANGE BOLT	8
20	***	COVER	1
21	***	BOLT	1
22	***	SPRING WASHER	1
23	***	BOLT	2
24	***	SPRING WASHER	2
25	***	PLAIN WASHER	2

NS - Not Shown

\*\*\* - Contact Allmand for more information.

## 3.4 - Tail Lights and Tail Light Harness

**To Be Determined**

000000\_A

# Maxi-Power™ 45 T4F

SN 23-000001 and UP

## 3.4 - Tail Lights and Tail Light Harness

Item	Allmand No.	Part Description	Qty.
1	***	to be determined	
2	***		
3	***		
4	***		
5	***		
6	***		
7	***		
8	***		
9	***		
10	***		

NS - Not Shown

\*\*\* - Contact Allmand for more information.

Go to Discount-Equipment.com to order your parts

## 3.5 - Cam Lock Group

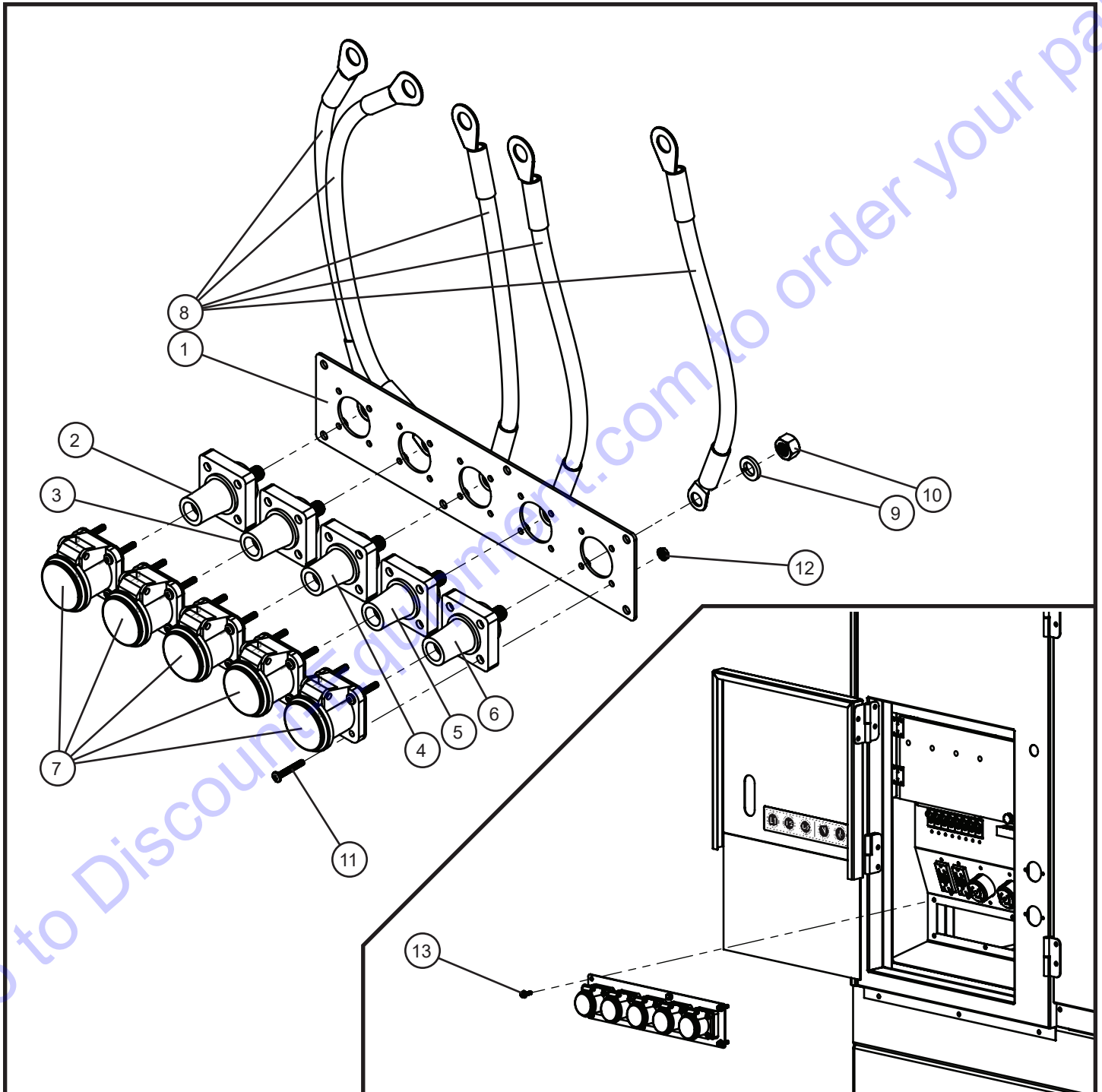

# Maxi-Power™ 45 T4F

SN 23-000001 and UP

## 3.5 - Cam Lock Group

Item	Allmand No.	Part Description	Qty.
1	112509P	CAM LOCK MOUNT PLATE	1
2	113242	CAM LOCK BLACK FEMALE 90° 600V 400A	1
3	113243	CAM LOCK RED FEMALE 90° 600V 400A	1
4	113244	CAM LOCK BLUE FEMALE 90° 600V 400A	1
5	113245	CAM LOCK WHITE FEMALE 90° 600V 400A	1
6	113246	CAM LOCK GREEN FEMALE 90° 600V 400A	1
7	112424	CAM LOCK CLEAR COVER 90°	5
8	112573	CAM LOCK CABLE KIT MP 45	1
9	043085	1/2 SPLITLOCK WASHER	5
10	044045	1/2-13 HEX NUT	5
11	041035	#10-24 x 1-1/4 PHILLIPS MACHINE SCREW	20
12	044016	#10-24 KEPS HEX NUT	20
13	055001	M6-1.0 x 20 HEX HEAD FLANGE BOLT	6
NS	112422	CAM LOCK 1/0 CABLE SCHEMATIC	1

NS - Not Shown

\*\*\* - Contact Allmand for more information.

## 3.6 - Block Heater, Battery Heater and Charger (1 of 2)

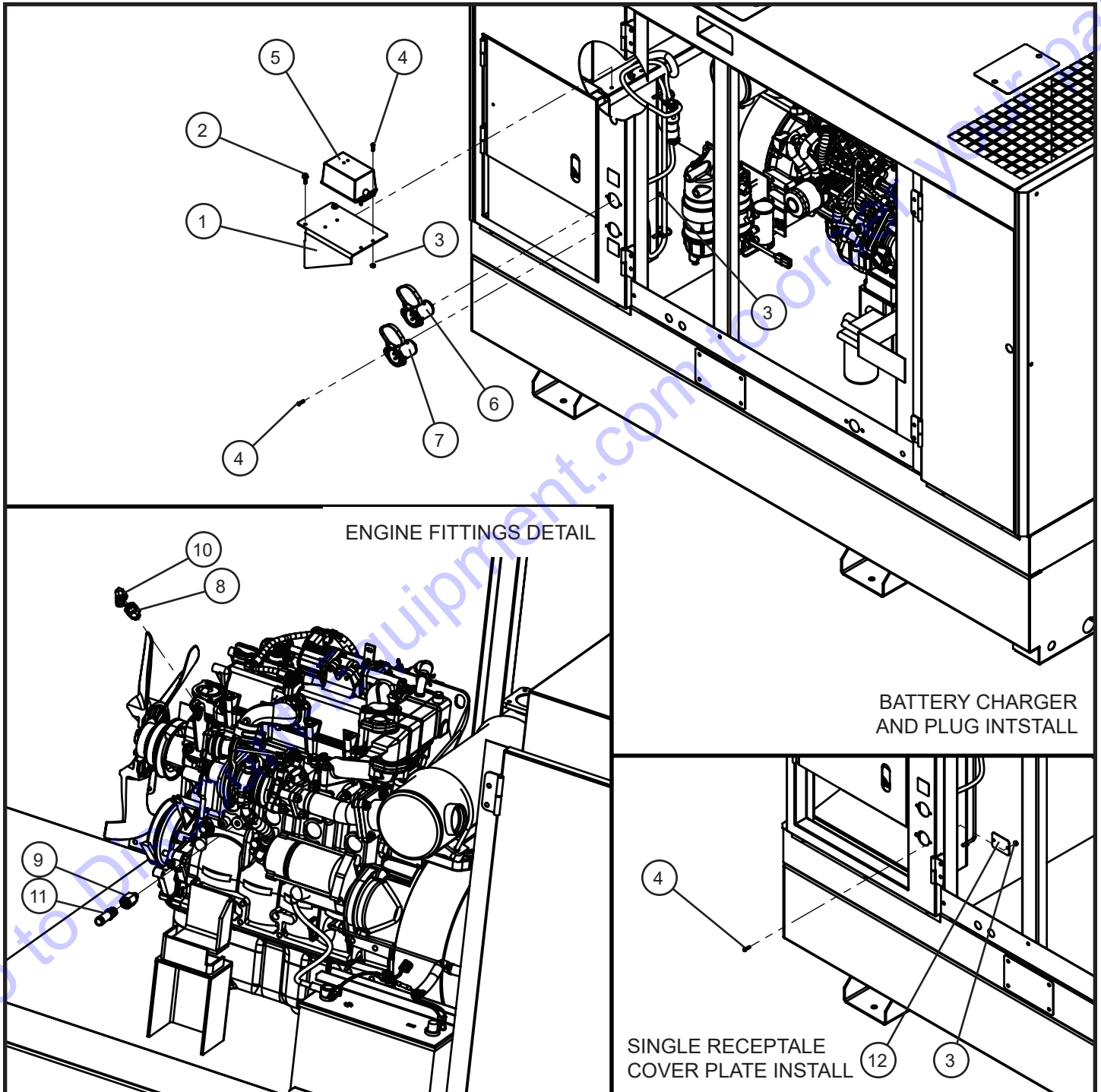



# Maxi-Power™ 45 T4F

SN 23-000001 and UP

## 3.6 - Block Heater, Battery Heater and Charger (1 of 2)

Item	Allmand No.	Part Description	Qty.
1	112523P	ARCTIC PACKAGE ACCESSORY MOUNT	1
2	055001	M6-1.0 x 20 HEX HEAD FLANGE BOLT	2
3	044016	#10-24 KEPS HEX NUT	8
4	041027	#10-24 x 3/4 PHILLIPS ROUND HEAD	8
5	112600	BATTERY CHARGER MAXI-POWER 45	1
6	112621	RECESSED PLUG MAXI-POWER 40, 45, & 150	1
7	112602	RECESSED PLUG MAXI-POWER 45	1
8	104798	FITTING ADAPTOR 3/8" BSPT TO 3/8" NPT	1
9	112581	FITTING ADAPTOR 1/4" BSPT TO 3/8" NPT	1
10	112592	90° FITTING HOSE BARB	1
11	112652	FITTING HOSE BARB 3/8" NPT - 5/8" BARB	1
12	113868P	RECEPTACLE PLUG BLOCK OFF PLATE	1
NS	112608	PLUG 3-PRONG MALE	2
NS	022202	LOOM FLEX GUARD 3/8 x 35.00	1
NS	022202	LOOM FLEX GUARD 3/8 x 15.00	1
NS	022202	LOOM FLEX GUARD 3/8 x 21.00	1
NS	022207	LOOM FLEX GUARD 5/8 x 44.00	1
NS	068090	CABLE TIE 8"	14
NS	112638	ARCTIC PACKAGE SCHEMATIC	1

NS - Not Shown

\* \* \* - Contact Allmand for more information.

## 3.6 - Block Heater, Battery Heater and Charger (2 of 2)

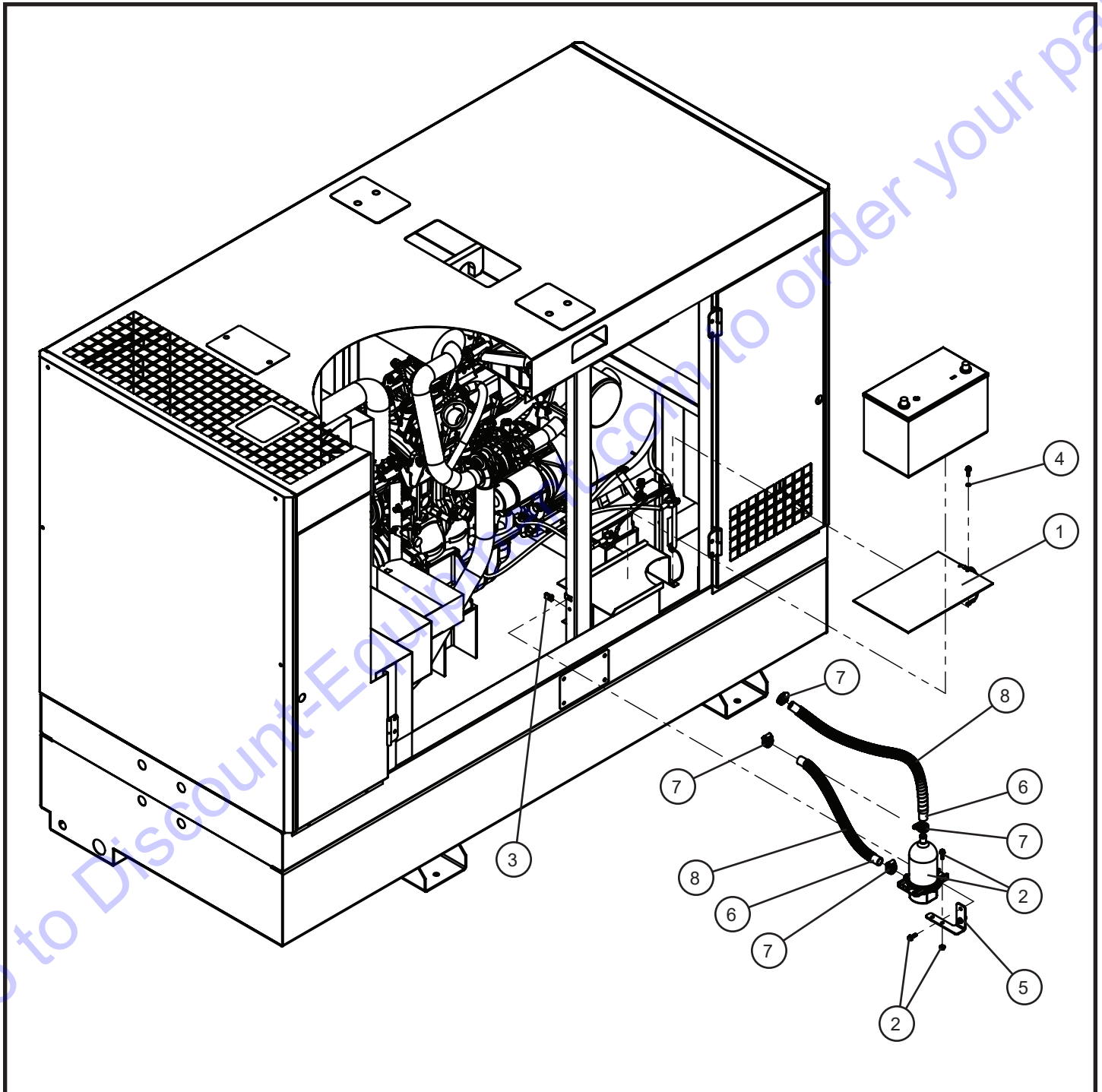

# Maxi-Power™ 45 T4F

SN 23-000001 and UP

## 3.6 - Block Heater, Battery Heater and Charger (2 of 2)

Item	Allmand No.	Part Description	Qty.
1	112599	BATTERY HEATER MAXI-POWER 45	1
2	112601	BLOCK HEATER MAXI-POWER	1
3	044106	1/4-20 EXTRUDED U NUT	2
4	043050	1/4 INTERNAL TOOTH LOCK WASHER	1
5	112593P	BLOCK HEATER MOUNT	1
6	081025	5/8 HEATER HOSE x 22.00	2
7	045033	#10 HOSE CLAMP WORM GEAR	4
8	022211	1.0 LOOM GUARD x 20.00	2

NS - Not Shown

\* \* \* - Contact Allmand for more information.

Go to Discount-Equipment.com to order your parts

## 3.7 - Battery Disconnect

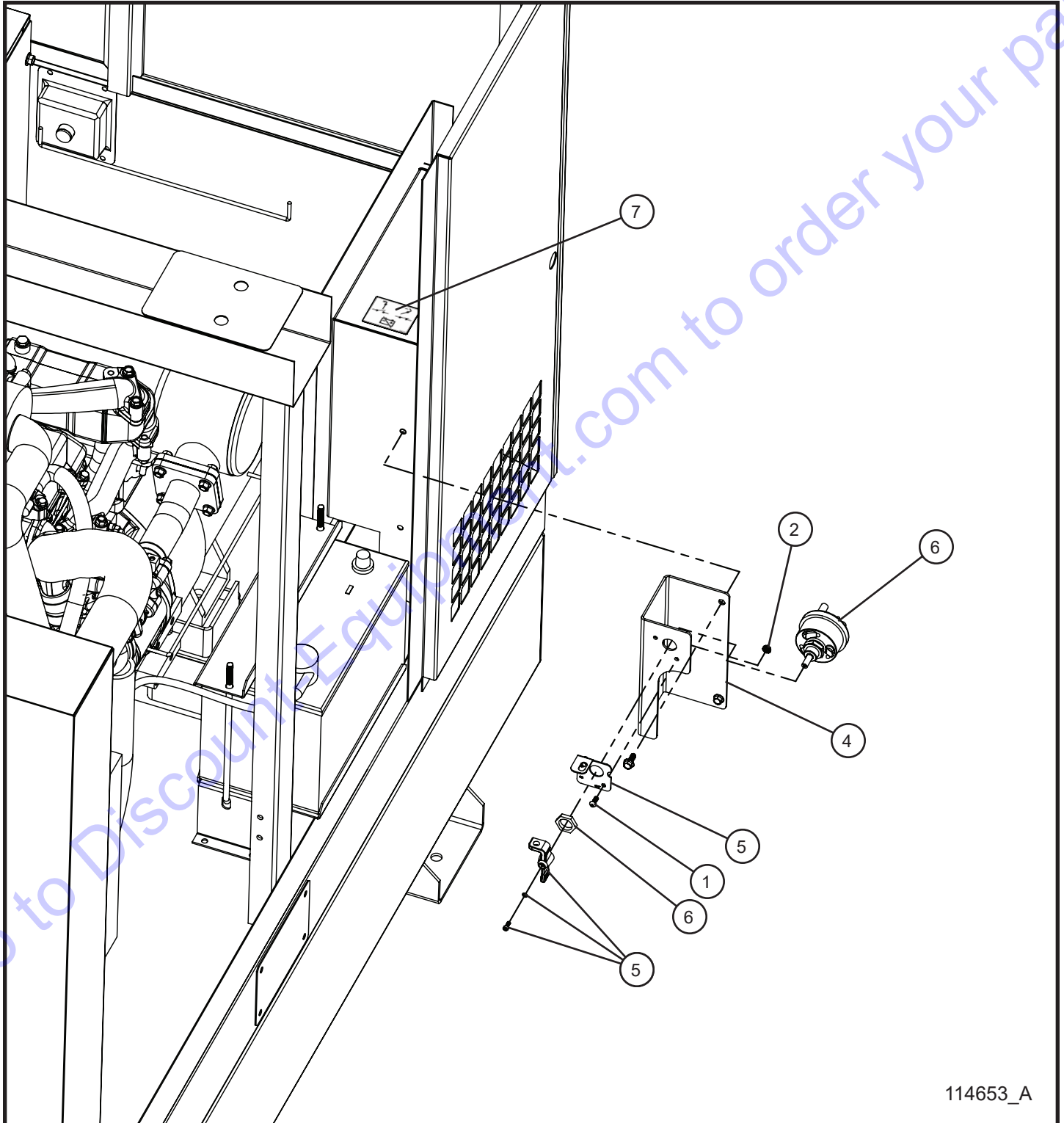

114653\_A

# Maxi-Power™ 45 T4F

SN 23-000001 and UP

## 3.7 - Battery Disconnect

Item	Part No.	Part Description	Qty.
1	041024	#10-24 x 1/2 PH-ROUND HEAD MACHINE SCREW	2
2	044016	#10-24 KEPS HEX NUT	2
3	105111	BATTERY DISCONNECT BLACK CABLE x 42.0	1
4	114663P	BATTERY DISCONNECT MOUNT	1
5	103483	BATTERY DISCONNECT LOCK OUT	1
6	102534	BATTERY DISCONNECT SWITCH	1
7	104777	BATTERY DISCONNECT DECAL	1

Go to Discount-Equipment.com to order your parts

## 4.1 - Right and Top Side Enclosure Decals

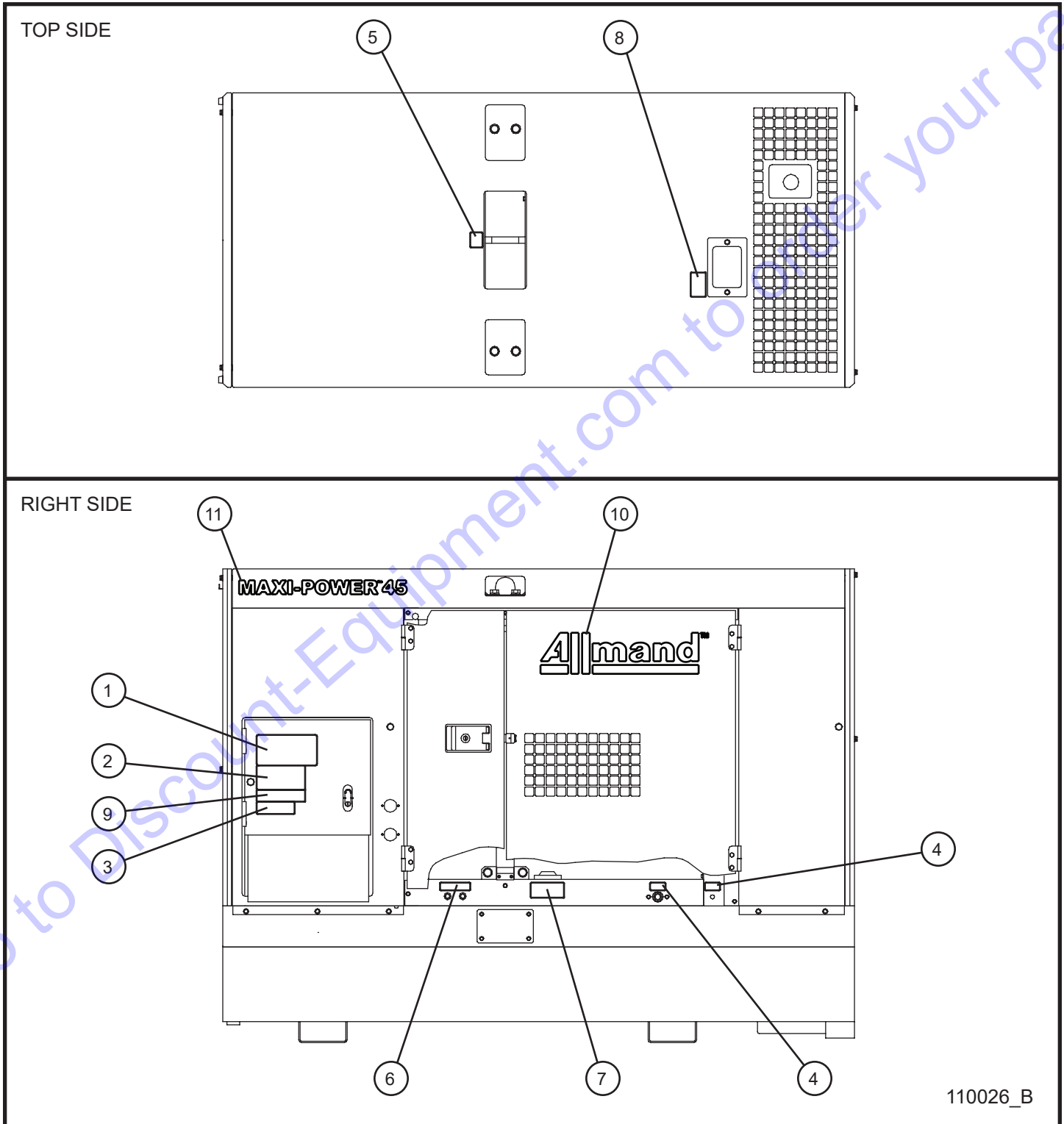

# Maxi-Power™ 45 T4F

SN 23-000001 and UP

## 4.1 - Right and Top Side Enclosure Decals

Item	Allmand No.	Part Description	Qty.
1	***	PLATE (OUTPUT)	1
2	112987	PLATE (HIGH VOLTAGE)	1
3	112804	PLATE COMPLETE SET (CAUTION, CABLE)	1
4	116784	PLATE COMPLETE SET (FUEL, RADIATOR, ENGINE OIL, AND OIL FENCE DRAINS)	1
5	116791	PLATE (FUEL RETURN, FUEL INLET)	1
6	116793	PLATE (DIESEL FUEL)	1
7	116786	PLATE (CAUTION, RADIATOR CAP)	1
8	112989	PLATE (WARNING, ELECTRIC SHOCK)	1
9	116801	PLATE (LIFT POSITION)	1
10	110286	SMALL BLACK ALLMAND BRANDING DECAL	1
11	109014	MAXI-POWER 45 DECAL	1

NS - Not Shown

\*\*\* - Contact Allmand for more information.

## 4.2 - Left and Front Side Enclosure Decals

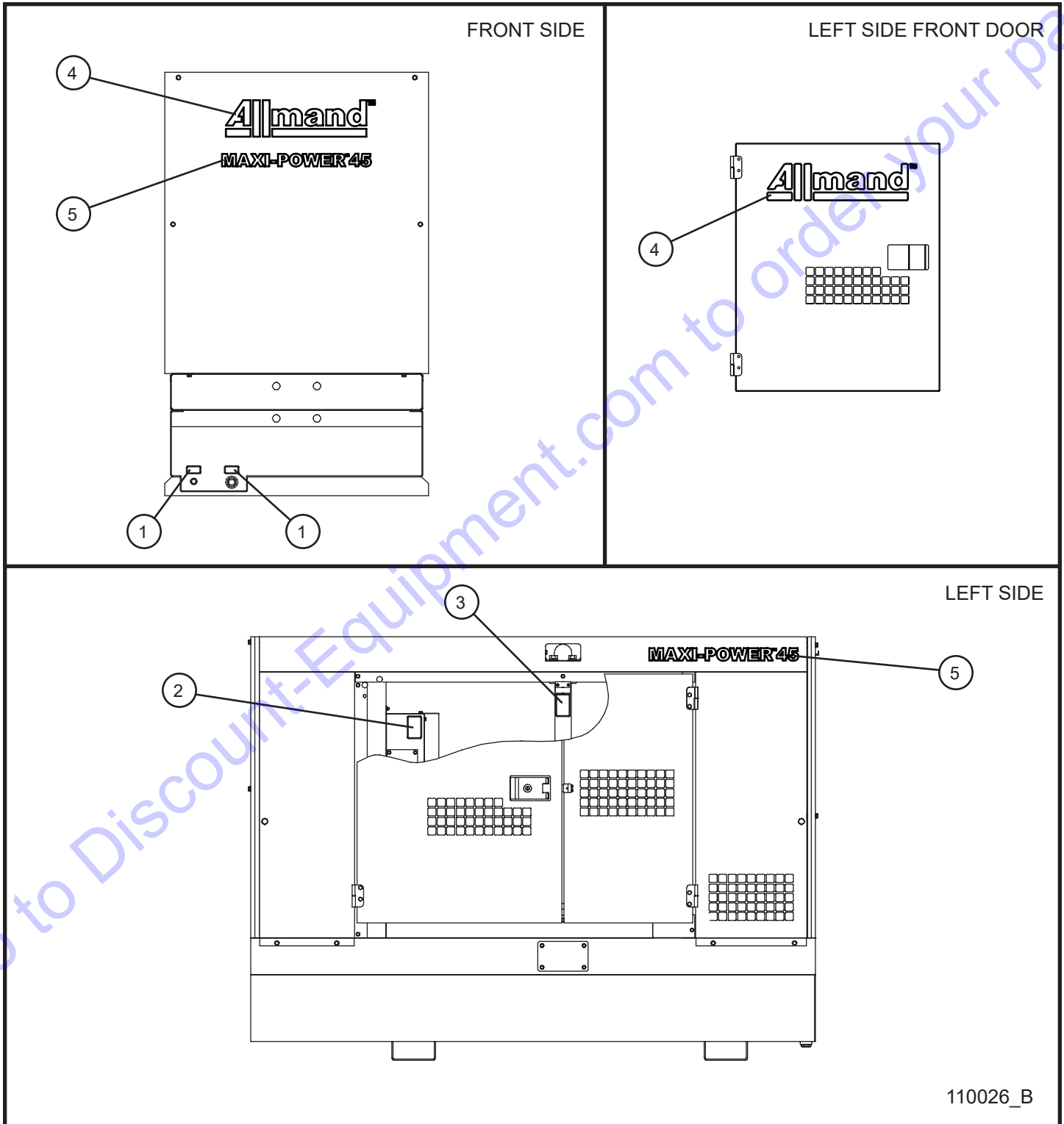



# Maxi-Power™ 45 T4F

SN 23-000001 and UP

## 4.2 - Left and Front Side Enclosure Decals

Item	Allmand No.	Part Description	Qty.
1	116784	PLATE COMPLETE SET (FUEL, RADIATOR, ENGINE OIL, AND OIL FENCE DRAINS)	1
2	114418	PLATE (WARNING, PULLEY)	1
3	114416	PLATE (CAUTION, HIGH TEMP.)	1
4	110286	SMALL BLACK ALLMAND BRANDING DECAL	1
5	109014	MAXI-POWER 45 DECAL	1

NS - Not Shown

\*\*\* - Contact Allmand for more information.

Go to Discount-Equipment.com to order your parts

## 4.3 - Rear Side Enclosure and Control Box Decals

CONTROL BOX DETAIL

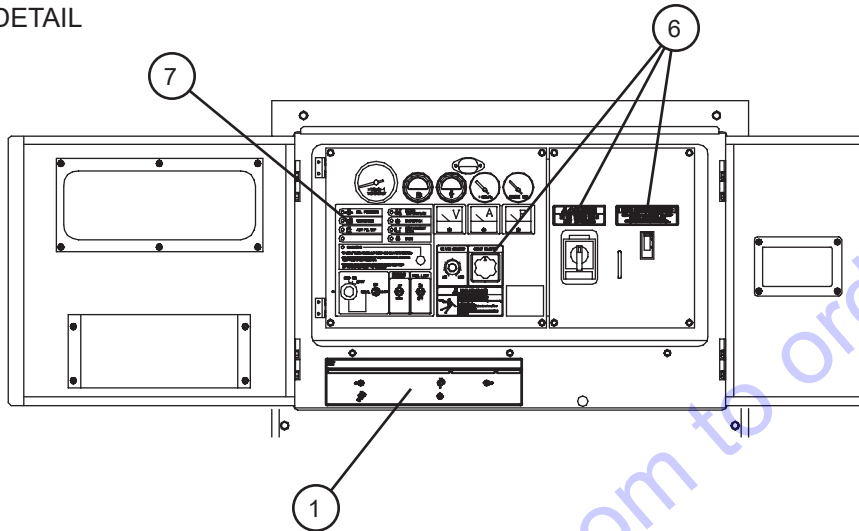

RIGHT SIDE

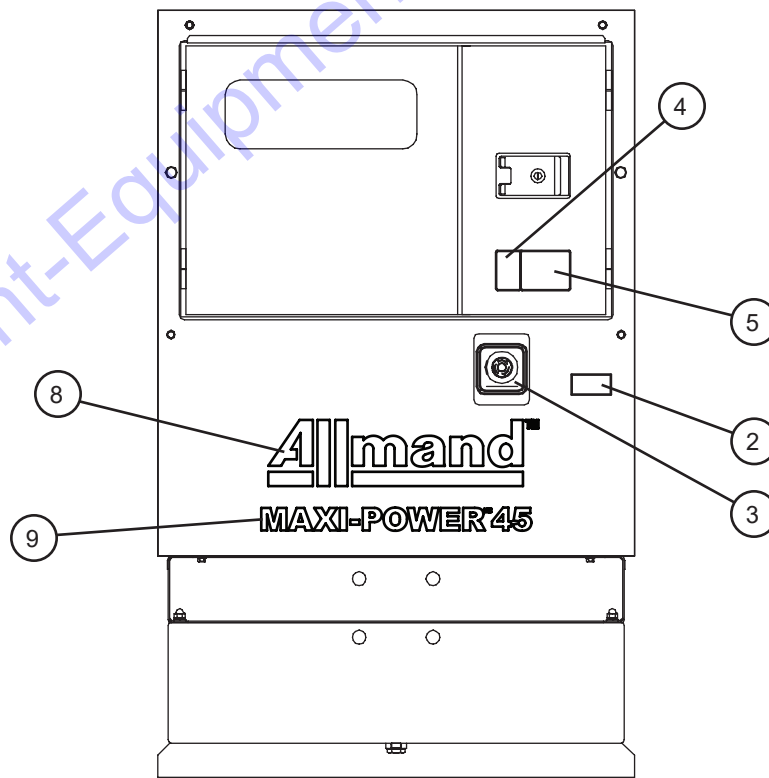

110026\_B

# Maxi-Power™ 45 T4F

SN 23-000001 and UP

## 4.3 - Rear Side Enclosure and Control Box Decals

Item	Allmand No.	Part Description	Qty.
1	***	PLATE (OPERATION)	1
2	***	PLATE (CALIFORNIA)	1
3	112844	PLATE (EMERGENCY STOP)	1
4	116787	PLATE (WARNING, EXHAUST GASES)	1
5	112811	PLATE (DANGER, EXHAUST GASES)	1
6	***	PLATE (IN-PANE)	1
7	***	PLATE (WARNING, LAMP)	1
8	110286	SMALL BLACK ALLMAND BRANDING DECAL	1
9	109014	MAXI-POWER 45 DECAL	1

NS - Not Shown

\*\*\* - Contact Allmand for more information.

Go to Discount-Equipment.com to order your parts

## 4.4 - Electrical Decals

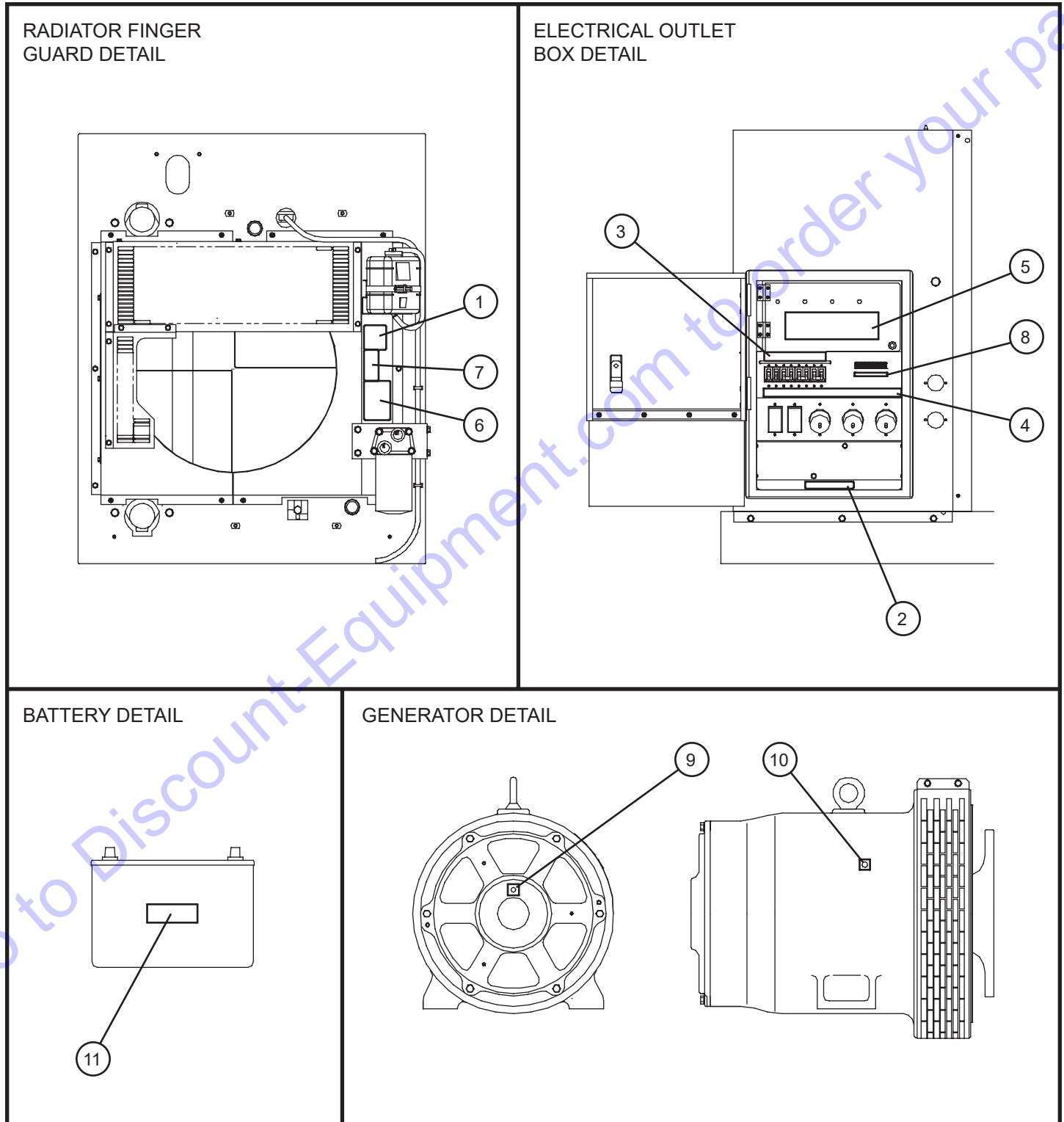

# Maxi-Power™ 45 T4F

SN 23-000001 and UP

## 4.4 - Electrical Decals

Item	Allmand No.	Part Description	Qty.
1	116790	PLATE (LLC)	1
2	112804	PLATE COMPLETE SET (CAUTION, CABLE)	1
3	116805	PLATE (BREAKER)	1
4	116796	PLATE (SOCKET)	1
5	116779	PLATE (WIRING CHART)	1
6	116795	PLATE (CHANGED FUEL REFILL)	1
7	114418	PLATE (WARNING, PULLEY)	1
8	116792	PLATE (2 WIRE TERMINAL PLATE)	1
9	116782	PLATE (INDICATOR)	1
10	116783	PLATE (INDICATOR)	1
11	116785	PLATE (DANGER, BATTERY)	1

NS - Not Shown

\*\*\* - Contact Allmand for more information.

## 4.3 - Cam Lock and Arctic Package Decals

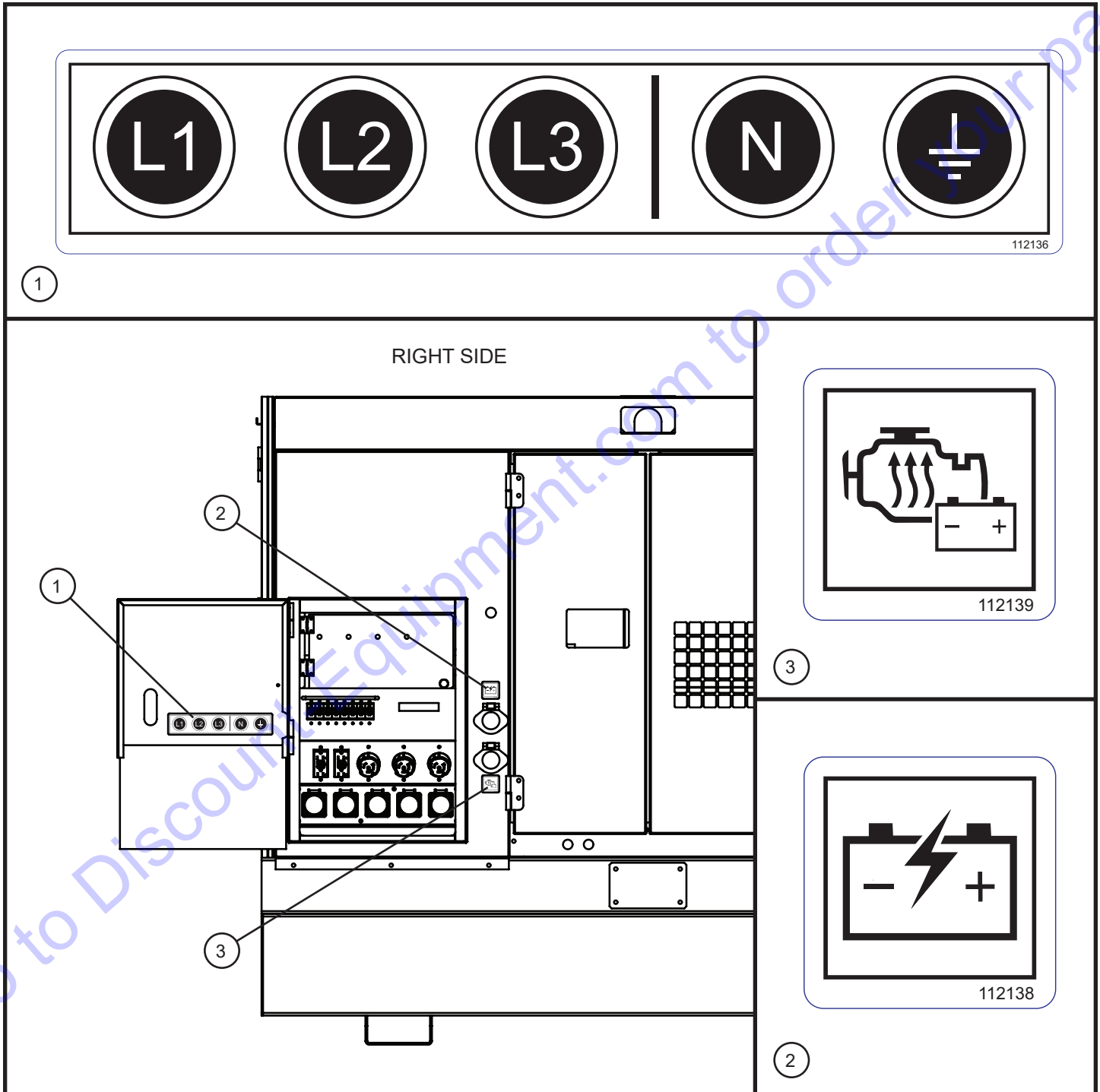

# Maxi-Power™ 45 T4F

SN 23-000001 and UP

## 4.3 - Cam Lock and Arctic Package Decals

Item	Allmand No.	Part Description	Qty.
1	112136	CAM LOCK MAXI-POWER DECAL	1
2	112138	BATTERY CHARGER DECAL	1
3	112139	ENGINE AND BATTERY HEATER DECAL	1

NS - Not Shown

\* \* \* - Contact Allmand for more information.

Go to Discount-Equipment.com to order your parts

# PARTS FINDER

**Search Website  
by Part Number**



**Search Manual  
Library For Parts  
Manual & Lookup Part  
Numbers – Purchase  
or Request Quote**

**Search Manuals**

Enter your information to help us find the right parts manual for your machine.

\* Brand:

\* Model:

\* Serial:

\* Part Number:

SEARCH

**Can't Find Part or  
Manual? Request Help  
by Manufacturer,  
Model & Description**

**Parts Order Form**

Please fill in the following information to help us find the right part for your machine.

MANUFACTURER:

MODEL:

DESCRIPTION:

SEARCH

Discount-Equipment.com is your online resource for quality parts & equipment.

Florida: **561-964-4949** Outside Florida TOLL FREE: **877-690-3101**

**Need parts?**

Click on this link: <http://www.discount-equipment.com/category/5443-parts/> and choose one of the options to help get the right parts and equipment you are looking for. Please have the machine model and serial number available in order to help us get you the correct parts. If you don't find the part on the website or on one of the online manuals, please fill out the request form and one of our experienced staff members will get back to you with a quote for the right part that your machine needs.

We sell worldwide for the brands: Genie, Terex, JLG, MultiQuip, Mikasa, Essick, Whiteman, Mayco, Toro Stone, Diamond Products, Generac Magnum, Airman, Haulotte, Barreto, Power Blanket, Nifty Lift, Atlas Copco, Chicago Pneumatic, Allmand, Miller Curber, Skyjack, Lull, Skytrak, Tsurumi, Husquvarna Target, Stow, Wacker, Sakai, Mi-T-M, Sullair, Basic, Dynapac, MBW, Weber, Bartell, Bennar Newman, Haulotte, Ditch Runner, Menegotti, Morrison, Contec, Buddy, Crown, Edco, Wyco, Bomag, Laymor, EZ Trench, Bil-Jax, F.S. Curtis, Gehl Pavers, Heli, Honda, ICS/PowerGrit, IHI, Partner, Imer, Clipper, MMD, Koshin, Rice, CH&E, General Equipment, Amida, Coleman, NAC, Gradall, Square Shooter, Kent, Stanley, Tamco, Toku, Hatz, Kohler, Robin, Wisconsin, Northrock, Oztec, Toker TK, Rol-Air, APT, Wylie, Ingersoll Rand / Doosan, Innovatech, Con X, Ammann, Mecalac, Makinex, Smith Surface Prep, Small Line, Wanco, Yanmar



# Maxi-Power™ 45 T4F

**Allmand®**

**Discount  
Equipment**

[www.discount-equipment.com](http://www.discount-equipment.com)

Go to [Discount-Equipment.com](http://Discount-Equipment.com) to order your parts