

en **Schematic Manual**
MAXI-POWER™ 15XR



www.discount-equipment.com

PARTS FINDER

**Search Website
by Part Number**



**Search Manual
Library For Parts
Manual & Lookup Part
Numbers – Purchase
or Request Quote**

Search Manuals

Enter your information to help us find the right parts manual for your machine.

* Brand:

* Model:

* Serial:

* Part Number:

SEARCH

**Can't Find Part or
Manual? Request Help
by Manufacturer,
Model & Description**

Parts Order Form

Please fill in the following information to help us find the right part for your machine.

Manufacturer:	<input type="text"/>
Model:	<input type="text"/>
Description:	<input type="text"/>
Part Number:	<input type="text"/>
Quantity:	<input type="text"/>
Notes:	<input type="text"/>

Submit

Discount-Equipment.com is your online resource for quality parts & equipment.

Florida: **561-964-4949** Outside Florida TOLL FREE: **877-690-3101**

Need parts?

Click on this link: <http://www.discount-equipment.com/category/5443-parts/> and choose one of the options to help get the right parts and equipment you are looking for. Please have the machine model and serial number available in order to help us get you the correct parts. If you don't find the part on the website or on one of the online manuals, please fill out the request form and one of our experienced staff members will get back to you with a quote for the right part that your machine needs.

We sell worldwide for the brands: Genie, Terex, JLG, MultiQuip, Mikasa, Essick, Whiteman, Mayco, Toro Stone, Diamond Products, Generac Magnum, Airman, Haulotte, Barreto, Power Blanket, Nifty Lift, Atlas Copco, Chicago Pneumatic, Allmand, Miller Curber, Skyjack, Lull, Skytrak, Tsurumi, Husquvarna Target, Stow, Wacker, Sakai, Mi-T-M, Sullair, Basic, Dynapac, MBW, Weber, Bartell, Bennar Newman, Haulotte, Ditch Runner, Menegotti, Morrison, Contec, Buddy, Crown, Edco, Wyco, Bomag, Laymor, EZ Trench, Bil-Jax, F.S. Curtis, Gehl Pavers, Heli, Honda, ICS/PowerGrit, IHI, Partner, Imer, Clipper, MMD, Koshin, Rice, CH&E, General Equipment, Amida, Coleman, NAC, Gradall, Square Shooter, Kent, Stanley, Tamco, Toku, Hatz, Kohler, Robin, Wisconsin, Northrock, Oztec, Toker TK, Rol-Air, APT, Wylie, Ingersoll Rand / Doosan, Innovatech, Con X, Ammann, Mecalac, Makinex, Smith Surface Prep, Small Line, Wanco, Yanmar

TABLE OF CONTENTS

Tail Light and Electric Brake Harness Schematic (114032)	(1.1)
4/4 50/60Hz 11/15kW Generator Cord Schematic (115225)	(1.2)
CAT C1.5T Engine Harness Schematic (106553)	(1.3)
MP 15XR Deep Sea Control Harness Schematic (118347)	(1.4)
Low Fuel Sender Schematic (110089)	(1.5)
LSC or SLS Heated Fuel/Water Separator Schematic (105886)	(1.6)
Single Battery Charger Schematic (120199)	(1.7)
2-GFCI, 2-30A Twistlock, 2-50A Twistlock 15kW Outlet Schematic (118325)	(1.8)
2-GFCI, 2-30A Twistlock, 2-50A RV 15kW Outlet Schematic (118326)	(1.9)
2-GFCI, 2-30A RV, 2-50A RV 15/20kW Outlet Schematic (117461)	(1.10)
Shocker Valve Harness Schematic (106156)	(1.11)

Go to Discount-Equipment.com to order your parts

MAXI-POWER™ 15XR

WIRE SCHEMATIC PAGE CONNECTION TABLE

Schematic Page	1st Connection Page(s)	2nd Connection Page(s)	3rd Connection Page(s)	4th Connection Page(s)
Tail Light and Electric Brake Harness Schematic (1.1)	n/a	n/a	n/a	n/a
4/4 50/60Hz 11/15kW Generator Cord Schematic (1.2)	(1.4-5th)	(1.8-1st), (1.9-1st), or (1.10-1st)	(1.8-2nd), (1.9-2nd), or (1.10-2nd)	n/a
CAT C1.5T Engine Harness Schematic (1.3)	(1.4-1st)	(1.4-2nd)	(1.4-3rd)	(1.4-4th)
MP 15XR Deep Sea Control Harness Schematic (1.4)	(1.3-1st)	(1.3-2nd)	(1.3-3rd)	(1.3-4th)

Schematic Page	5th Connection Page(s)	6th Connection Page(s)	7th Connection Page(s)	8th Connection Page(s)
CAT C1.5T Engine Harness Schematic (1.3)	(1.4-6th)	(1.5-1st)	n/a	n/a
MP 15XR Deep Sea Control Harness Schematic (1.4)	(1.2-1st)	(1.3-5th)	(1.6-1st)	(1.6-2nd)

Schematic Page	1st Connection Page(s)	2nd Connection Page(s)	3rd Connection Page(s)	4th Connection Page(s)
Low Fuel Sender Schematic (1.5)	(1.3-6th)	n/a	n/a	n/a
LSC or SLS Heated Fuel/Water Separator Schematic (1.6)	(1.4-7th)	(1.4-8th)	n/a	n/a

WIRE SCHEMATIC PAGE CONNECTION TABLE

Schematic Page	1st Connection Page(s)	2nd Connection Page(s)	3rd Connection Page(s)	4th Connection Page(s)
Single Battery Charger Schematic (1.7)	n/a	n/a	n/a	n/a
2-GFCI, 2-30A Twistlock, 2-50A Twistlock 15kW Outlet Schematic (1.8)	(1.2-2nd)	(1.2-3rd)	n/a	n/a
2-GFCI, 2-30A Twistlock, 2-50A RV 15kW Outlet Schematic (1.9)	(1.2-2nd)	(1.2-3rd)	n/a	n/a
2-GFCI, 2-30A RV, 2-50A RV 15/20kW Outlet Schematic (1.10)	(1.2-2nd)	(1.2-3rd)	n/a	n/a
Shocker Valve Harness Schematic (1.11)	n/a	n/a	n/a	n/a

Go to Discount-Equipment.com to order your parts

MAXI-POWER™ 15XR

Go to Discount-Equipment.com to order your parts

1.1 - Tail Light and Electric Brake Harness Schematic

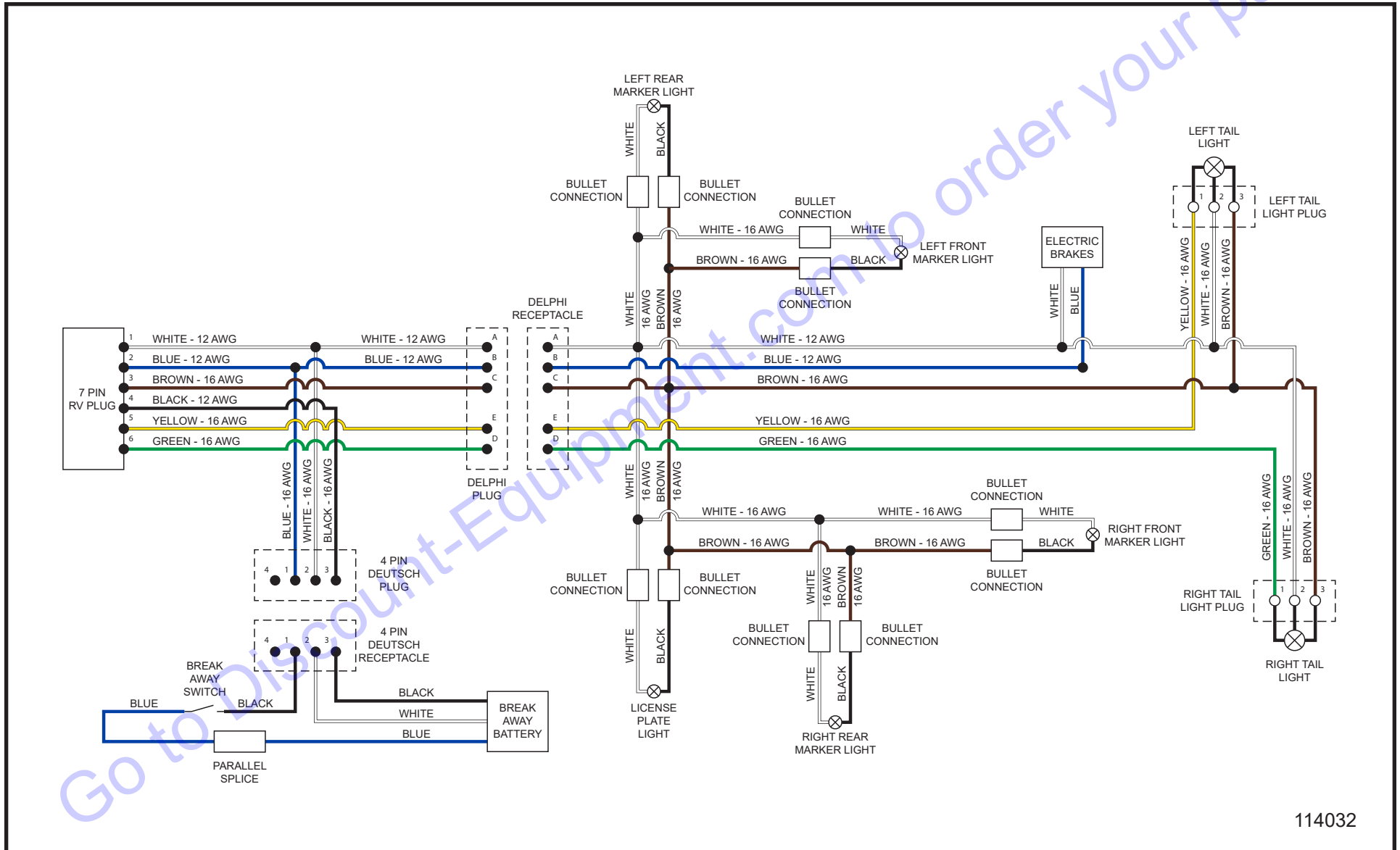

MAXI-POWER™ 15XR

1.2 - 4/4 50/60Hz 11/15kW Generator Cord Schematic

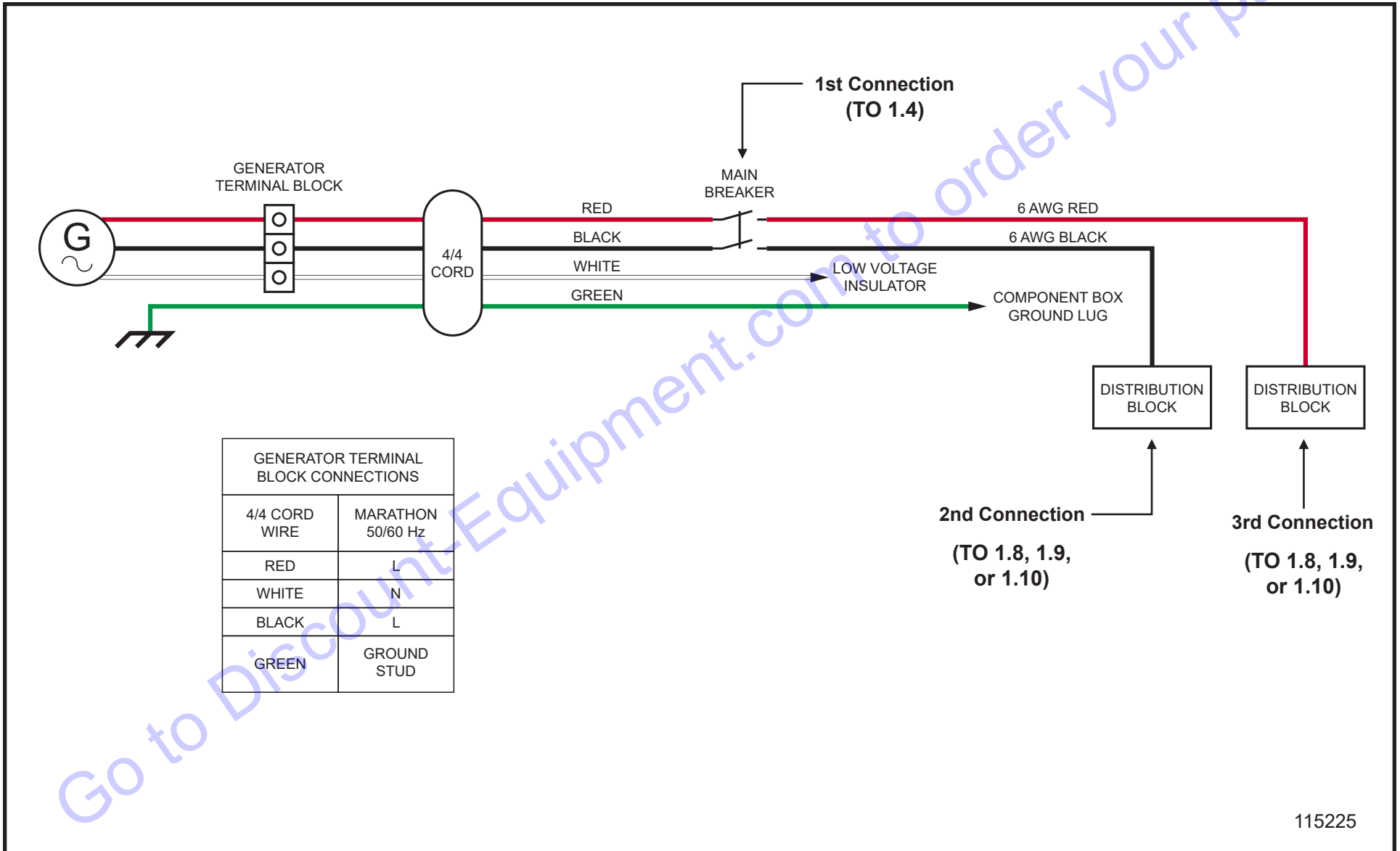

115225

1.3 - CAT C1.5T Engine Harness Schematic

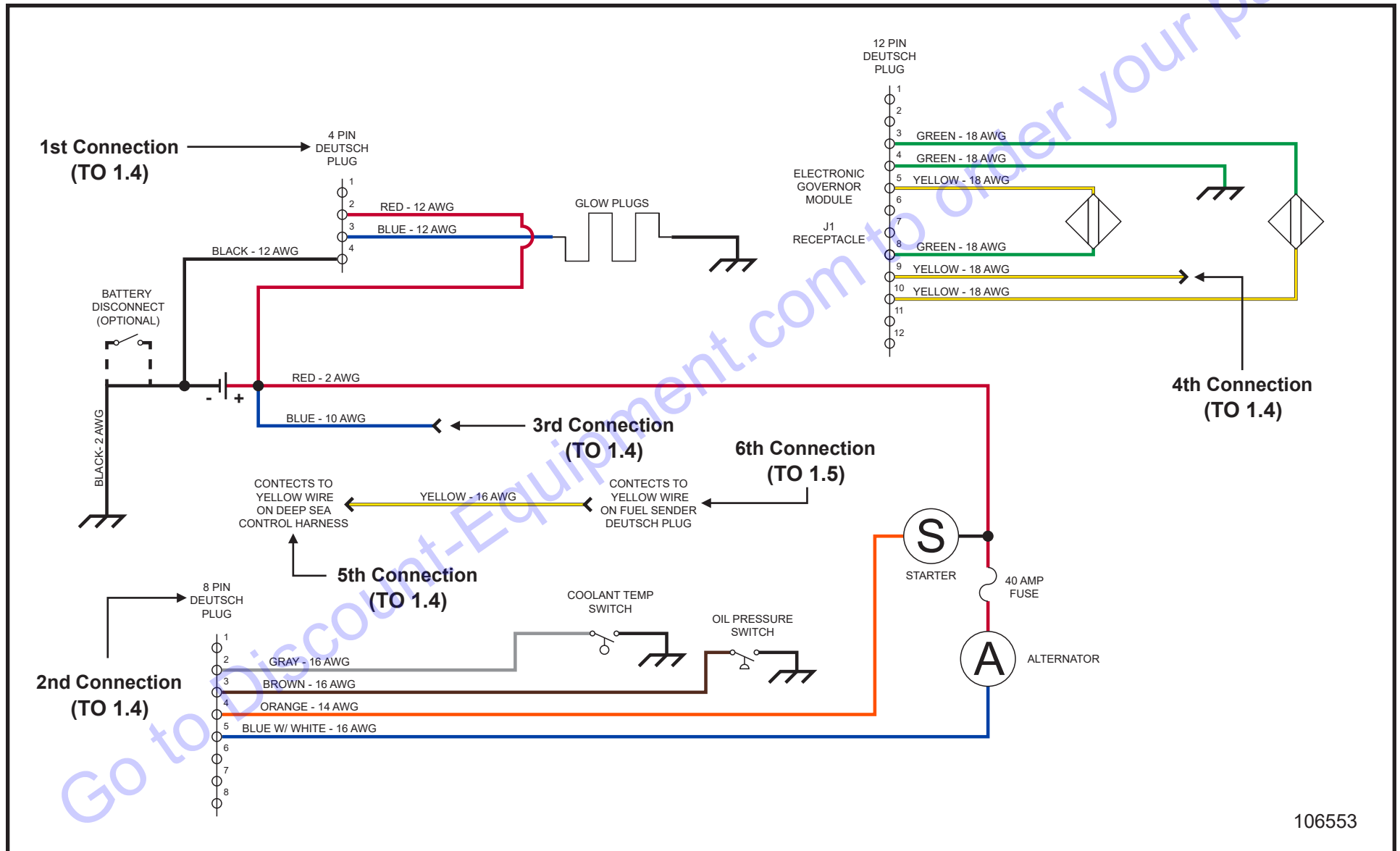

106553

MAXI-POWER™ 15XR

1.4 - MP 15XR Deep Sea Control Harness Schematic

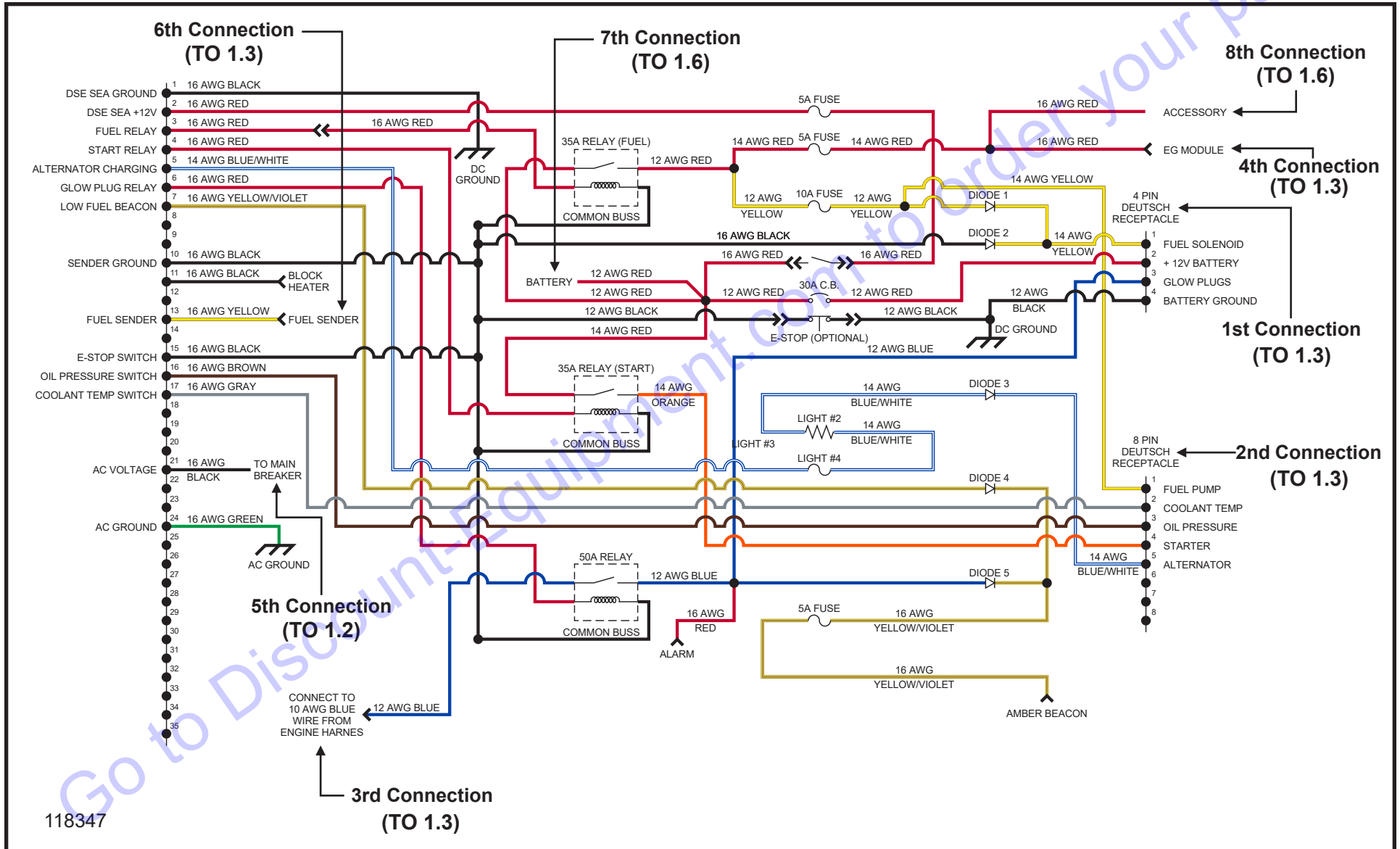

1.5 - Low Fuel Sender Schematic

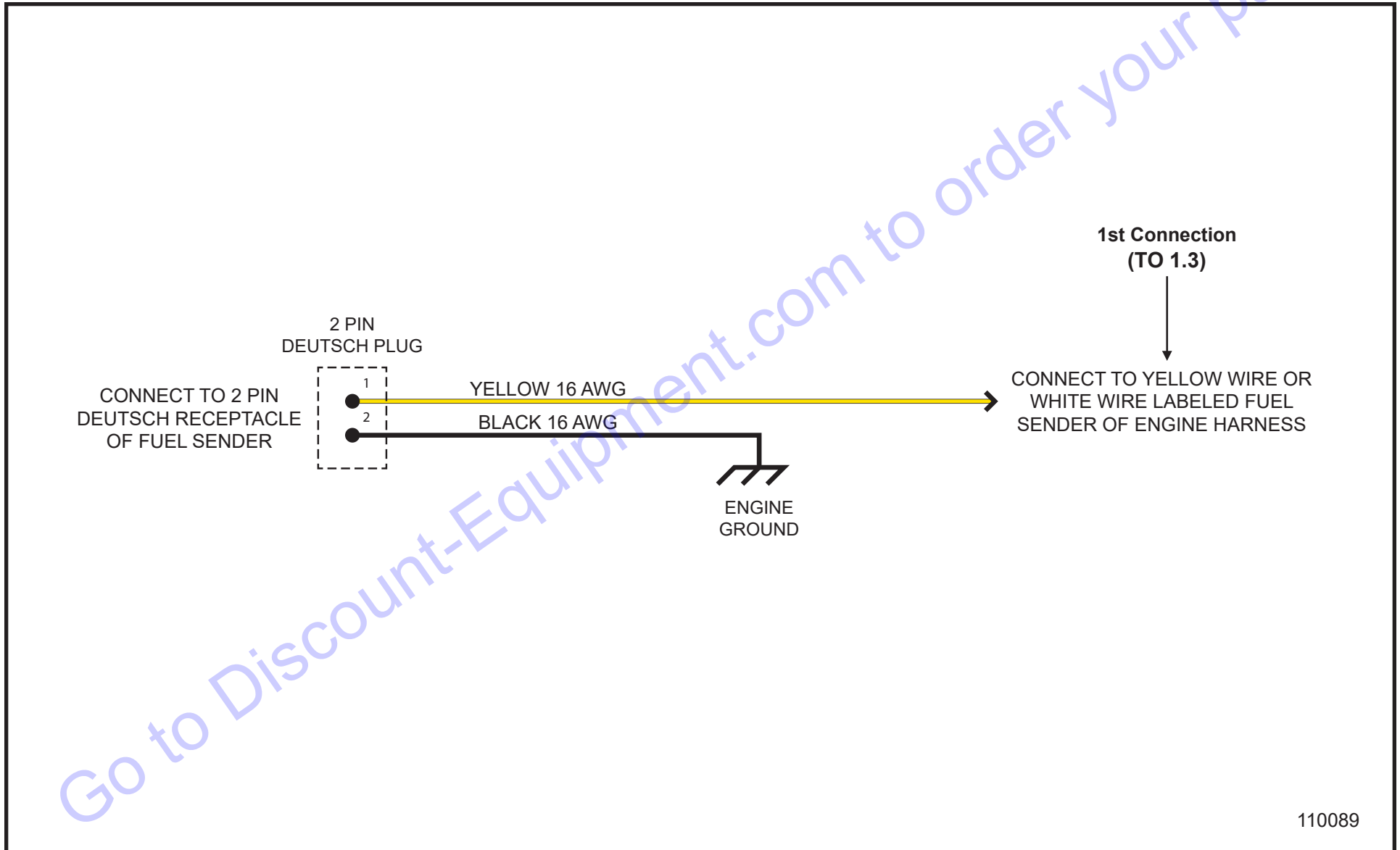

110089

MAXI-POWER™ 15XR

1.6 - LSC or SLS Heated Fuel/Water Separator Schematic

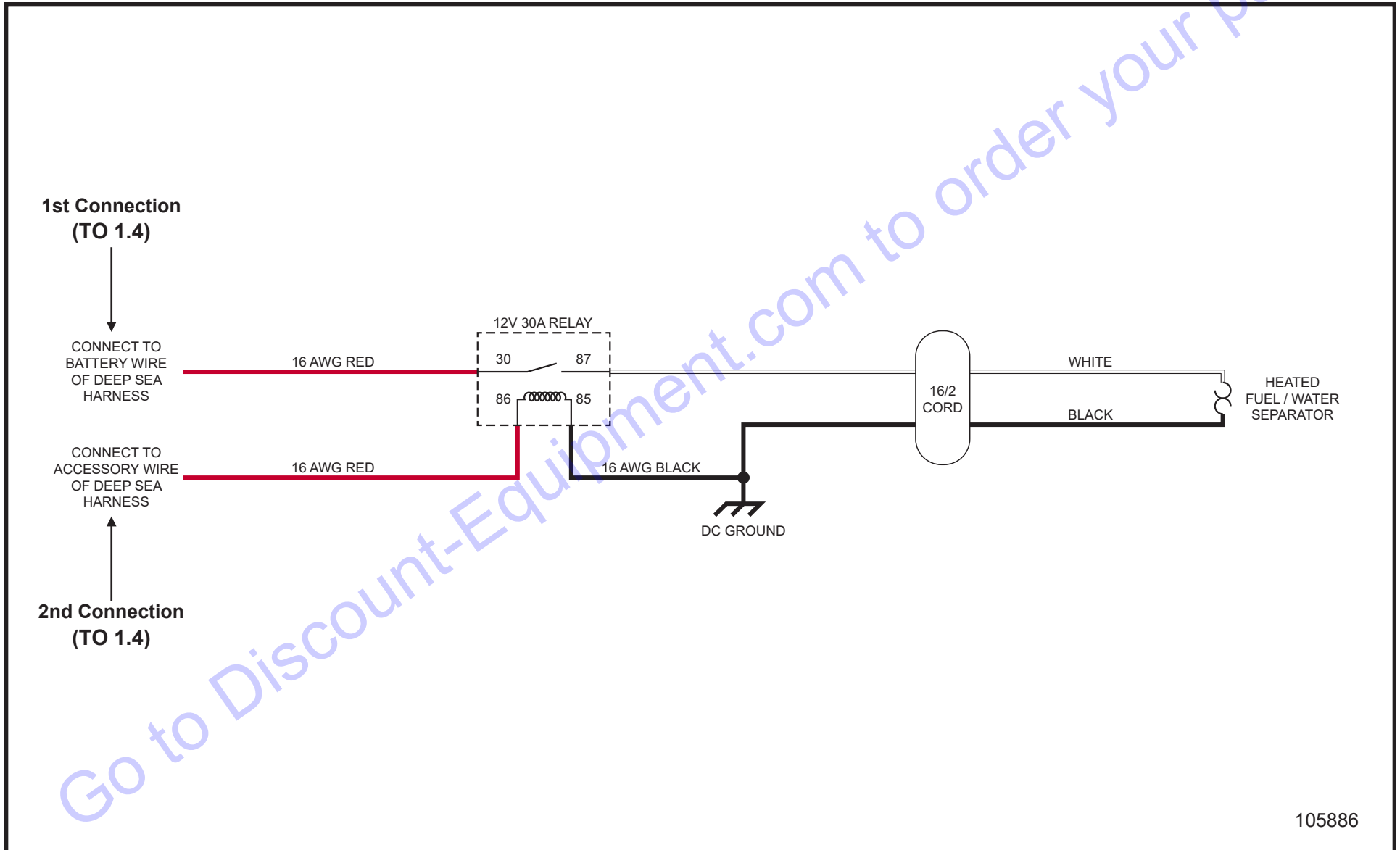

1.7 - Single Battery Charger Schematic

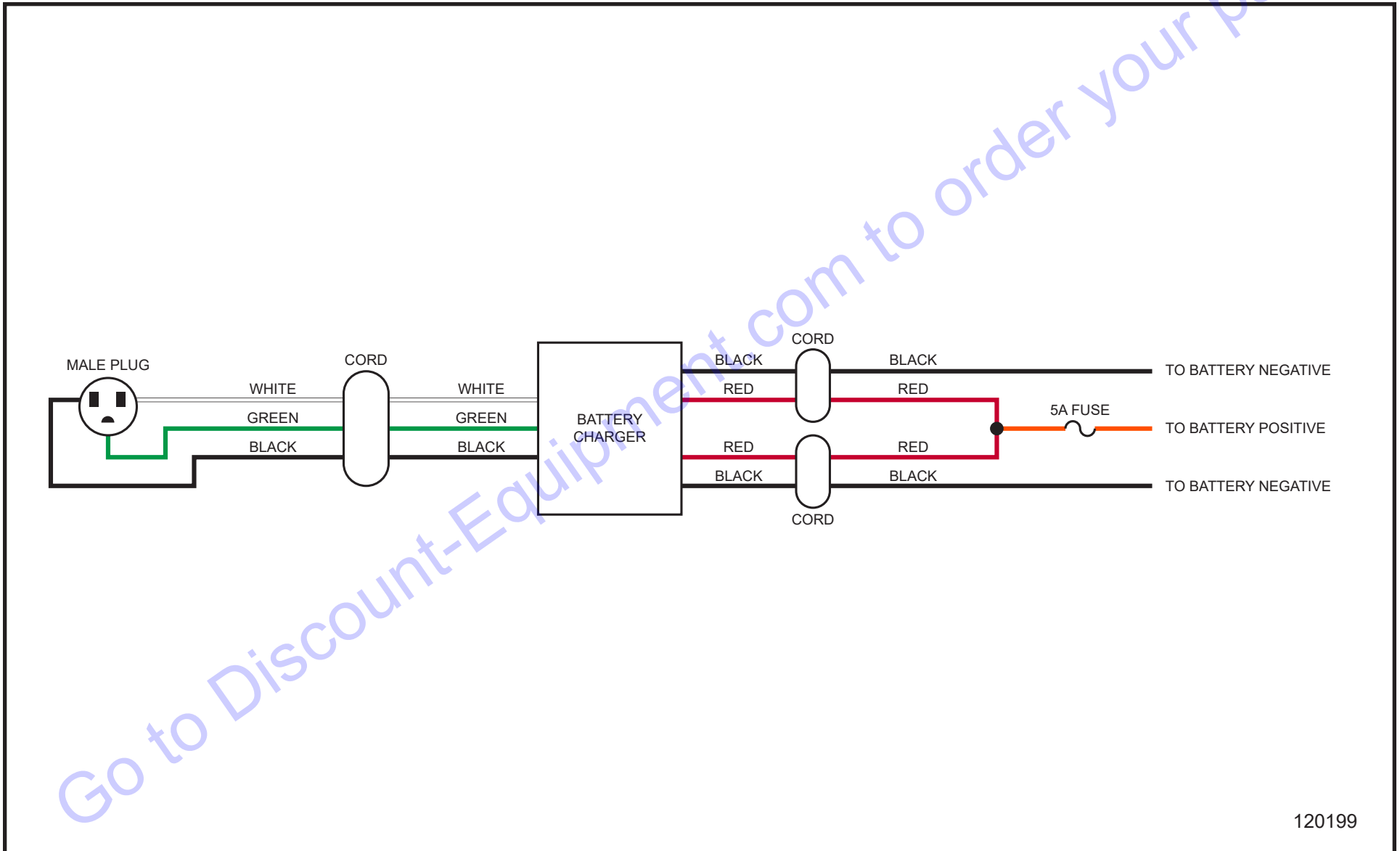

120199

MAXI-POWER™ 15XR

1.8 - 2-GFCI, 2-30A Twistlock, 2-50A Twistlock 15kW Outlet Schematic

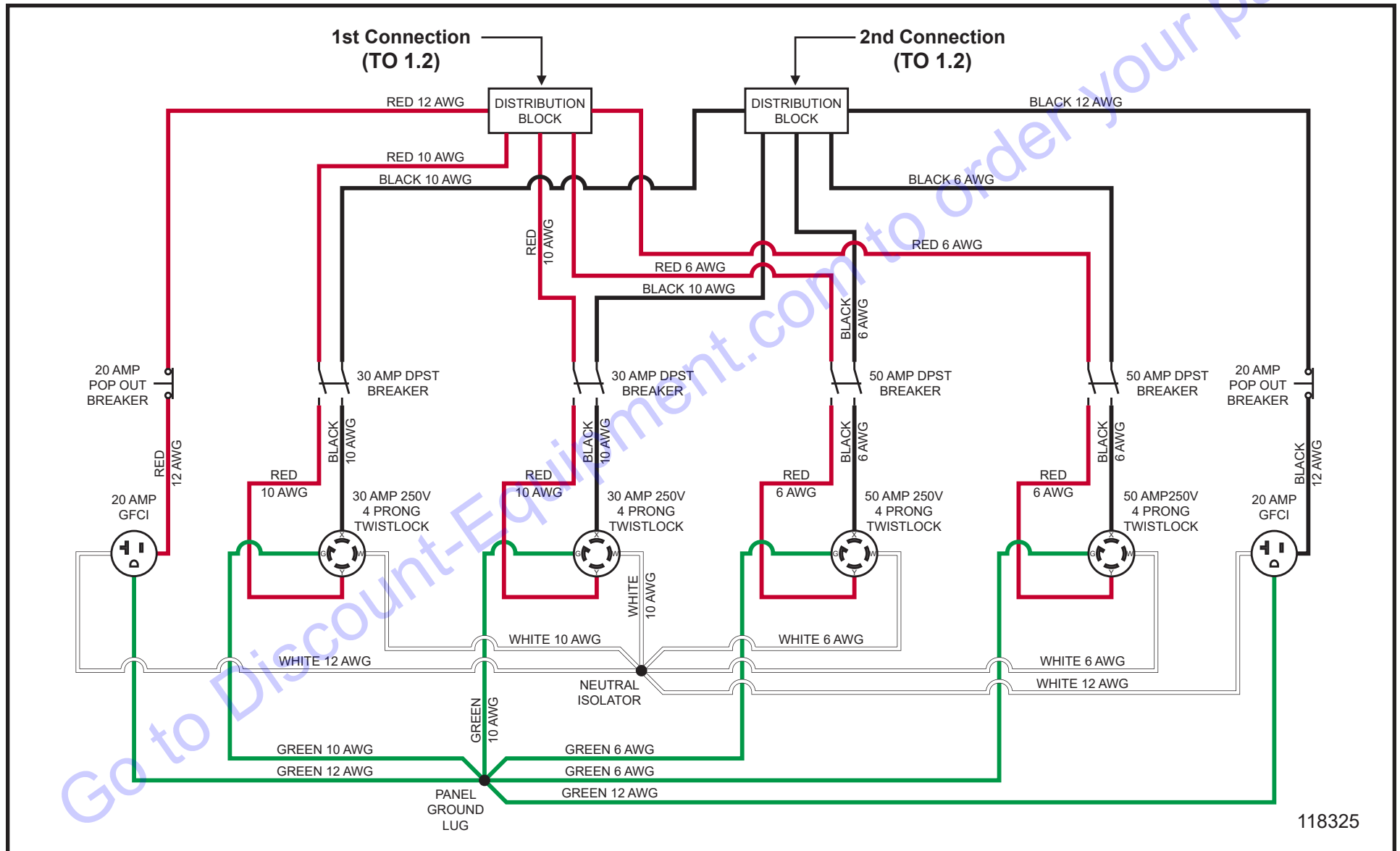

1.9 - 2-GFCI, 2-30A Twistlock, 2-50A RV 15kW Outlet Schematic

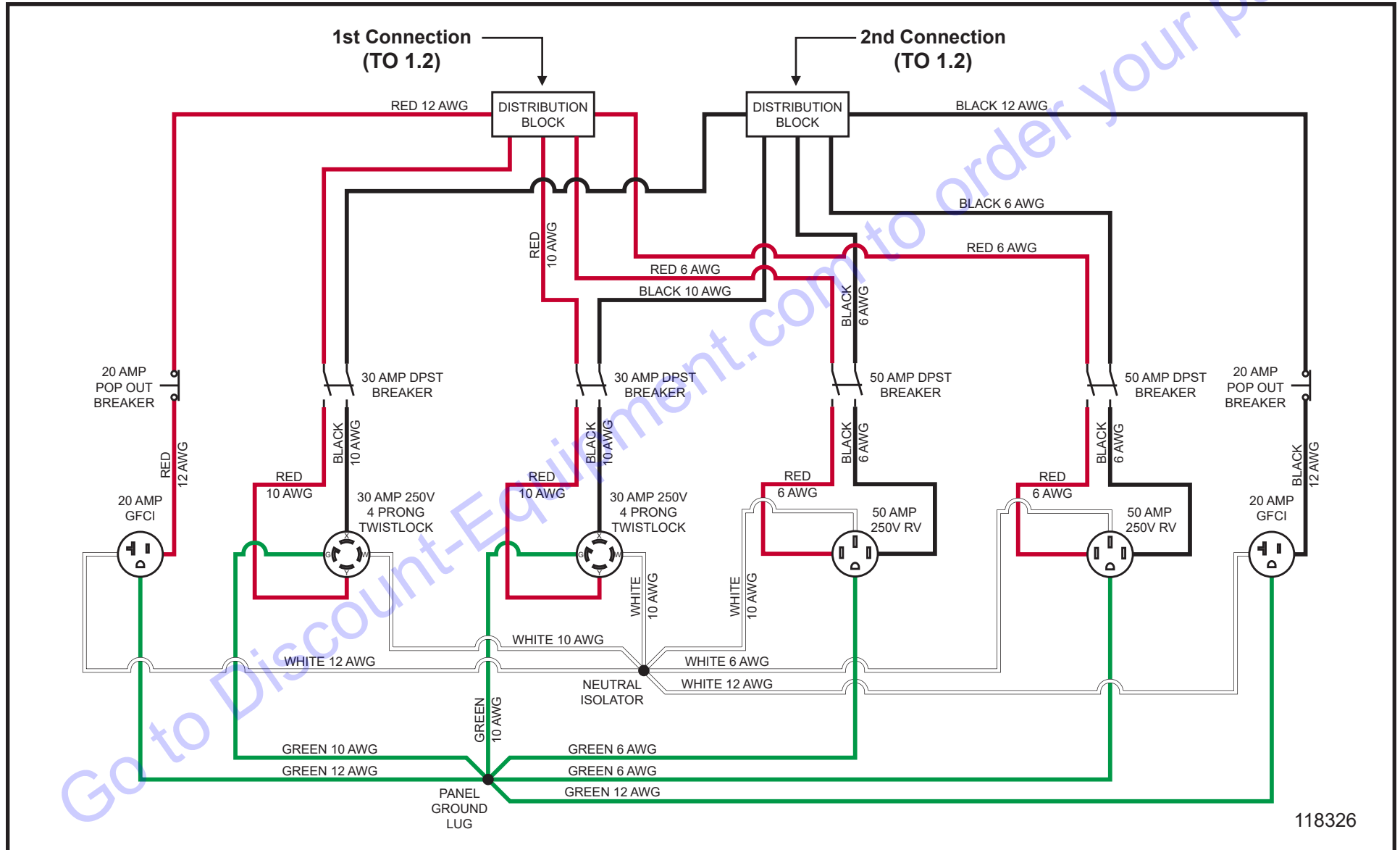

MAXI-POWER™ 15XR

1.10 - 2-GFCI, 2-30A RV, 2-50A RV 15kW Outlet Schematic

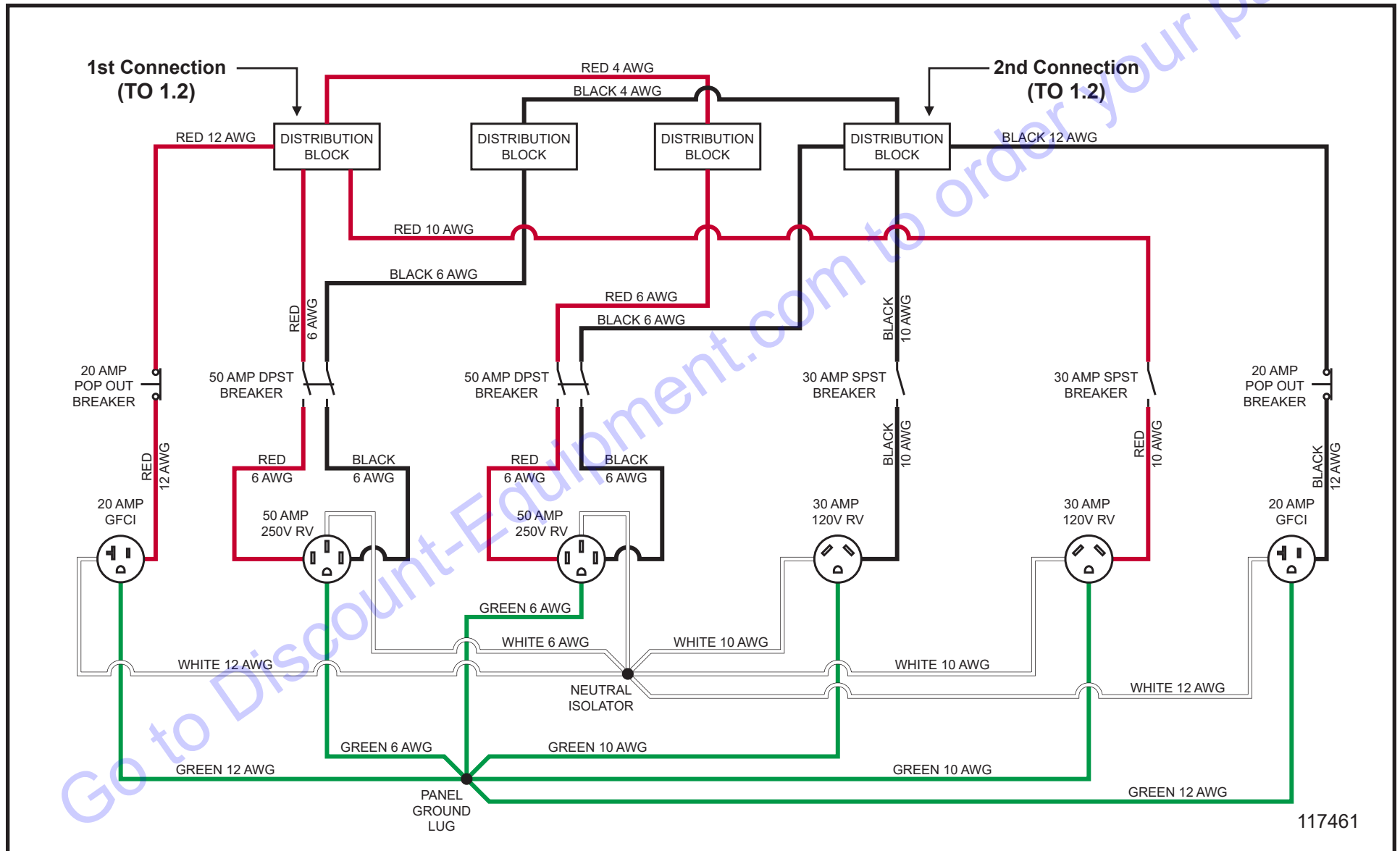

1.11 - Shocker Valve Harness Schematic

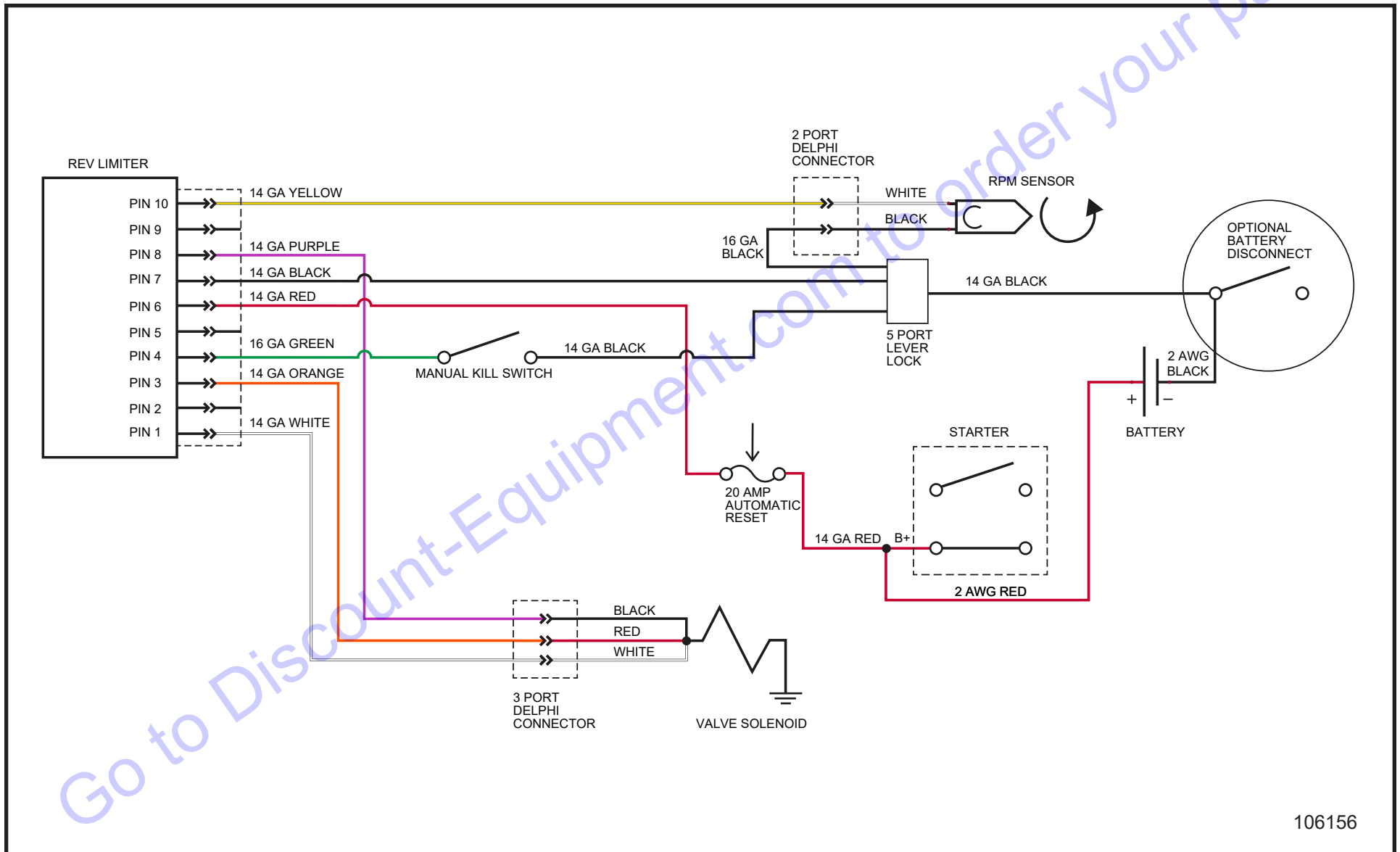

106156

MAXI-POWER™ 15XR

Go to Discount-Equipment.com to order your parts

MAXI-POWER™ 15XR

Allmand®

**Discount
Equipment**

www.discount-equipment.com

Go to Discount-Equipment.com to order your parts

PARTS FINDER

**Search Website
by Part Number**



**Search Manual
Library For Parts
Manual & Lookup Part
Numbers – Purchase
or Request Quote**

Search Manuals

Enter your information to help us find the right parts manual for your machine.

* Brand:

* Model:

* Serial:

* Part Number:

SEARCH

**Can't Find Part or
Manual? Request Help
by Manufacturer,
Model & Description**

Parts Order Form

Please fill in the following information to help us find the right part for your machine.

Manufacturer:	<input type="text"/>
Model:	<input type="text"/>
Description:	<input type="text"/>
Part Number:	<input type="text"/>
Quantity:	<input type="text"/>
Notes:	<input type="text"/>

Submit

Discount-Equipment.com is your online resource for quality parts & equipment.

Florida: **561-964-4949** Outside Florida TOLL FREE: **877-690-3101**

Need parts?

Click on this link: <http://www.discount-equipment.com/category/5443-parts/> and choose one of the options to help get the right parts and equipment you are looking for. Please have the machine model and serial number available in order to help us get you the correct parts. If you don't find the part on the website or on one of the online manuals, please fill out the request form and one of our experienced staff members will get back to you with a quote for the right part that your machine needs.

We sell worldwide for the brands: Genie, Terex, JLG, MultiQuip, Mikasa, Essick, Whiteman, Mayco, Toro Stone, Diamond Products, Generac Magnum, Airman, Haulotte, Barreto, Power Blanket, Nifty Lift, Atlas Copco, Chicago Pneumatic, Allmand, Miller Curber, Skyjack, Lull, Skytrak, Tsurumi, Husquvarna Target, Stow, Wacker, Sakai, Mi-T-M, Sullair, Basic, Dynapac, MBW, Weber, Bartell, Bennar Newman, Haulotte, Ditch Runner, Menegotti, Morrison, Contec, Buddy, Crown, Edco, Wyco, Bomag, Laymor, EZ Trench, Bil-Jax, F.S. Curtis, Gehl Pavers, Heli, Honda, ICS/PowerGrit, IHI, Partner, Imer, Clipper, MMD, Koshin, Rice, CH&E, General Equipment, Amida, Coleman, NAC, Gradall, Square Shooter, Kent, Stanley, Tamco, Toku, Hatz, Kohler, Robin, Wisconsin, Northrock, Oztec, Toker TK, Rol-Air, APT, Wylie, Ingersoll Rand / Doosan, Innovatech, Con X, Ammann, Mecalac, Makinex, Smith Surface Prep, Small Line, Wanco, Yanmar