

Allmand®



www.discount-equipment.com

MAXI-POWER™ 15XR™

MOBILE GENERATOR

The Maxi-Power 15XR, is an Allmand® premium single-phase towable generator providing the highest runtime in its class with a 100-gallon fuel tank. The rugged design is the most durable for job site applications, powering job site trailers and work sheds, as well as special events. Allmand has built its reputation in these industries and understands the rigor required to handle the tough job site challenges and needs. Allmand gets the job done.



A SUBSIDIARY OF



BRIGGS & STRATTON
CORPORATION

KEY FEATURES

Maxi-Power™ 15XR™ Mobile Generator

- 
- 15 kW / 15 kVA Single-Phase Towable Generator
 - Deep Sea 4520 controller with on screen fuel gauge, low fuel shutdown, scheduling, and auto-start
 - Remote engine oil and coolant drain Easily accessible at rear of trailer
 - All steel construction with durable powder coat finish
 - Emergency Stop
 - 100 Gallon fuel tank for extended runtime
 - Lift Ring and forklift pockets below the frame
 - 4-pin Trailer Connector
 - Tubular Axle with elliptical leaf springs
 - Reversible Coupler: Adjustable height - 2" ball / 3" pintle
 - Two-Stage Engine Air Filter
 - Heavy-duty Battery
 - CAT 1.5 Turbo engine with Marathon alternator
 - 110% Fluid Containment System of all on-board fluids
 - Electric Brakes
 - Tires ST205/75R15 radial load range D
 - VIN Package: stop, turn, tail lights / side marker lights / illuminated license plate bracket
 - Standard Outlet Package: (2) 20A GFCI, (2) 30A Twist Lock, (2) 50A 4-wire Twist Lock (single-phase only)

Model Number	15XR
Engine Make	Caterpillar
Engine Model	C1.5T
Engine- Generator Control Interface	Deep Sea 4520
Prime Power kVA (kw)*	15 (15)
Maximum Ambient Operating Temperature @ Full Output	118 °F (48 °C)
Run Time @ Full Load (hr)**	81.7
Sound Level @ 23'- Full Load- dBA	66
Sound Level @ 23'- 75% Full Load- dBA	64.8
Mechanical Output (Gross Hp)***	22.3
Engine Oil Capacity (gal)	1.75
Insulation Class	Class H
Battery (V)	12
Oil Change Interval (hr)	500
Weights	
Net Dry Weight (lbs)	2,417
Operating Wet Weight fuel FULL (lbs)	3,160
Number of Units on 48' Flatbed	7 units

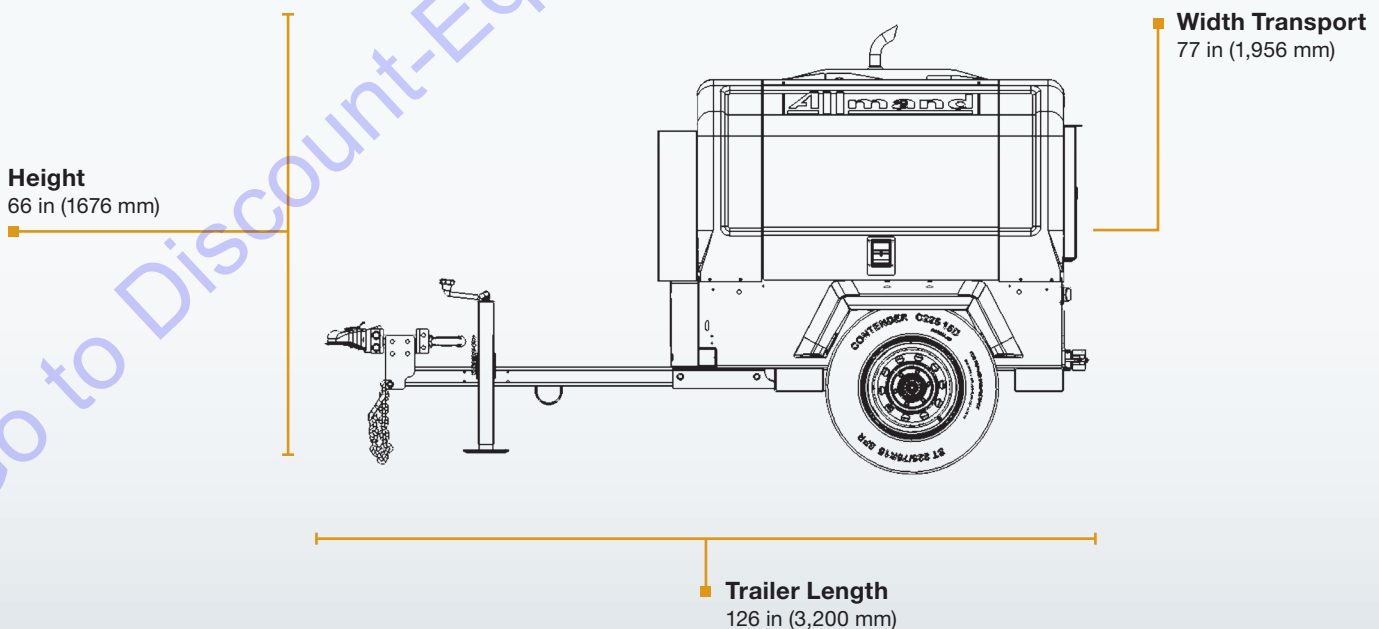

* Prime generator electrical output per Allmand® testing. ** Based on one hour run test full fuel tank consumption. *** All power levels are stated gross horsepower as rated by the engines manufacturers. Allmand® has a policy of continuous product improvement and reserves the right to modify its specifications at any time and without prior notice. See operator's manual or www.allmand.com website for complete warranty details.

OPTIONS

Maxi-Power™ 15XR™ Mobile Generator



Cold Weather Package

- Block Heater

Arctic Package

(Only available with Cold Weather Package)

- Heated fuel/water separator
- Radiator cover



Battery Charger

(loose cord)

Battery Heater

(loose cord)

Lockable Battery Disconnect

2" Bulldog Coupler

2-5/16" Bulldog Coupler

Intake Air Shutdown

Customer Telematics (Contact factory for lead time)

Skid Mount

CSA (Canada only)

Custom Paint

Outlet Package Option A

- (2) 20A GFCI
- (2) 30A Twist Lock
- (2) 50A RV

Outlet Package Option B

- (2) 20A GFCI
- (2) 30A RV
- (2) 50A RV



COMPROMISE NOTHING.

At Allmand, our sole focus is providing jobsite support equipment to help your customers get the job done. Whenever they need it. Wherever they are. And whatever it takes. What's more, our genuine commitment to you — the highest standard of service and lowest total cost of ownership — is simply unmatched. Choose the equipment that comes with complete confidence that jobsite productivity won't go dark at 2 a.m. **Allmand. Above All.**



www.discount-equipment.com



ALLMAND BROS., INC.
A subsidiary of Briggs & Stratton Corporation
Copyright ©2020. All rights reserved.

TO PURCHASE THIS PRODUCT PLEASE CONTACT US



**Equipment Financing and
Extended Warranties Available**



**Discount-Equipment.com is your online resource for
commercial and industrial quality parts and equipment sales.**

561-964-4949

visit us on line @ www.discount-equipment.com

Select an option below to find your Equipment

Search by Manufacturer

Search by Product Type

Request a Quote

We sell worldwide for the brands: Genie, Terex, JLG, MultiQuip, Mikasa, Essick, Whiteman, Mayco, Toro Stone, Diamond Products, Generac Magnum, Airman, Haulotte, Barreto, Power Blanket, Nifty Lift, Atlas Copco, Chicago Pneumatic, Allmand, Miller Curber, Skyjack, Lull, Skytrak, Tsurumi, Husquvarna Target, Stow, Wacker, Sakai, Mi-T-M, Sullair, Basic, Dynapac, MBW, Weber, Bartell, Bennar Newman, Haulotte, Ditch Runner, Menegotti, Morrison, Contec, Buddy, Crown, Edco, Wyco, Bomag, Laymor, EZ Trench, Bil-Jax, F.S. Curtis, Gehl Pavers, Heli, Honda, ICS/PowerGrit, IHI, Partner, Imer, Clipper, MMD, Koshin, Rice, CH&E, General Equipment, Amida, Coleman, NAC, Gradall, Square Shooter, Kent, Stanley, Tamco, Toku, Hatz, Kohler, Robin, Wisconsin, Northrock, Oztec, Toker TK, Rol-Air, APT, Wylie, Ingersoll Rand / Doosan, Innovatech, Con X, Ammann, Mecalac, Makinex, Smith Surface Prep, Small Line, Wanco, Yanmar