



MASONRY SAW PARTS LIST

MODEL CC500MXL2

June 2017

Part # 1801098

PARTS FINDER

**Search Website
by Part Number**



**Search Manual
Library For Parts
Manual & Lookup Part
Numbers – Purchase
or Request Quote**

Search Manuals

Enter your information to help us find the right parts manual for your machine.

* Brand:

* Model:

* Serial:

* Part Number:

SEARCH

**Can't Find Part or
Manual? Request Help
by Manufacturer,
Model & Description**

Parts Order Form

Please fill in the following information to help us find the right part for your machine.

Manufacturer:	<input type="text"/>
Model:	<input type="text"/>
Description:	<input type="text"/>
Part Number:	<input type="text"/>
Quantity:	<input type="text"/>
Notes:	<input type="text"/>

Discount-Equipment.com is your online resource for quality parts & equipment.

Florida: **561-964-4949** Outside Florida TOLL FREE: **877-690-3101**

Need parts?

Click on this link: <http://www.discount-equipment.com/category/5443-parts/> and choose one of the options to help get the right parts and equipment you are looking for. Please have the machine model and serial number available in order to help us get you the correct parts. If you don't find the part on the website or on one of the online manuals, please fill out the request form and one of our experienced staff members will get back to you with a quote for the right part that your machine needs.

We sell worldwide for the brands: Genie, Terex, JLG, MultiQuip, Mikasa, Essick, Whiteman, Mayco, Toro Stone, Diamond Products, Generac Magnum, Airman, Haulotte, Barreto, Power Blanket, Nifty Lift, Atlas Copco, Chicago Pneumatic, Allmand, Miller Curber, Skyjack, Lull, Skytrak, Tsurumi, Husquvarna Target, Stow, Wacker, Sakai, Mi-T-M, Sullair, Basic, Dynapac, MBW, Weber, Bartell, Bennar Newman, Haulotte, Ditch Runner, Menegotti, Morrison, Contec, Buddy, Crown, Edco, Wyco, Bomag, Laymor, EZ Trench, Bil-Jax, F.S. Curtis, Gehl Pavers, Heli, Honda, ICS/PowerGrit, IHI, Partner, Imer, Clipper, MMD, Koshin, Rice, CH&E, General Equipment, Amida, Coleman, NAC, Gradall, Square Shooter, Kent, Stanley, Tamco, Toku, Hatz, Kohler, Robin, Wisconsin, Northrock, Oztec, Toker TK, Rol-Air, APT, Wylie, Ingersoll Rand / Doosan, Innovatech, Con X, Ammann, Mecalac, Makinex, Smith Surface Prep, Small Line, Wanco, Yanmar

**Proposition 65
State of California**

Warning !

Engine exhaust and some its constituents are known to the State of California to cause cancer, birth defects, and/or other reproductive harm.

**Notification of Spark Arrester Requirement for
State of California**

It is a violation of Section 4442 or 4443 to use or operate the engine on any forest-covered, brush-covered, or grass-covered land unless the engine is equipped with a spark arrester, as defined in Section 4442, maintained in effective working order or the engine is constructed, equipped, and maintained for the prevention of fire pursuant to Section 4443.

TABLE OF CONTENTS

<u>Description</u>	<u>Page No.</u>
Pictorial Page Index – Electric Saw	4-5
Pictorial Page Index – Gas Saw	6-7
1.5HP-1PH Electric Motor Mount Assembly	8-9
2.0HP-1PH Electric Motor Mount Assembly	10-11
2.5HP-1PH Electric Motor Mount Assembly	12-13
3.0HP-1PH Electric Motor Mount Assembly	14-15
4.8HP Gas Engine Mount Assembly	16-17
6.5HP Gas Engine Mount Assembly - Vanguard	18-19
6.5HP Gas Engine Mount Assembly - Lifan.....	20-21
Frame Assembly	22
Upper Frame Head Weldment.....	24-25
Depth Lock Assembly.....	24-25
Leveling Arm Assembly.....	26
Conveyor Cart Assembly.....	27
Blade Guard Assembly – Electric	28
Blade Guard Assembly – Gas	29
Blade Shaft Assembly-Electric	30
Blade Shaft Assembly-Gas.....	31
Belt Guard Assembly – Electric	32
Belt Guard Assembly – Gas	33
Motor Belt Drive – Electric.....	34
Motor Belt Drive – Gas	35
Diaphragm Pump Assembly – Gas.....	36
Water Hose Assembly – Gas	37
Water Pump Assembly – Electric 115V	38
Water Pump Mounting Bracket and Belt Guard - Gas	39
Warranty	Rear Cover

CC500MXL2 Electric Saw
Pictorial Page Index

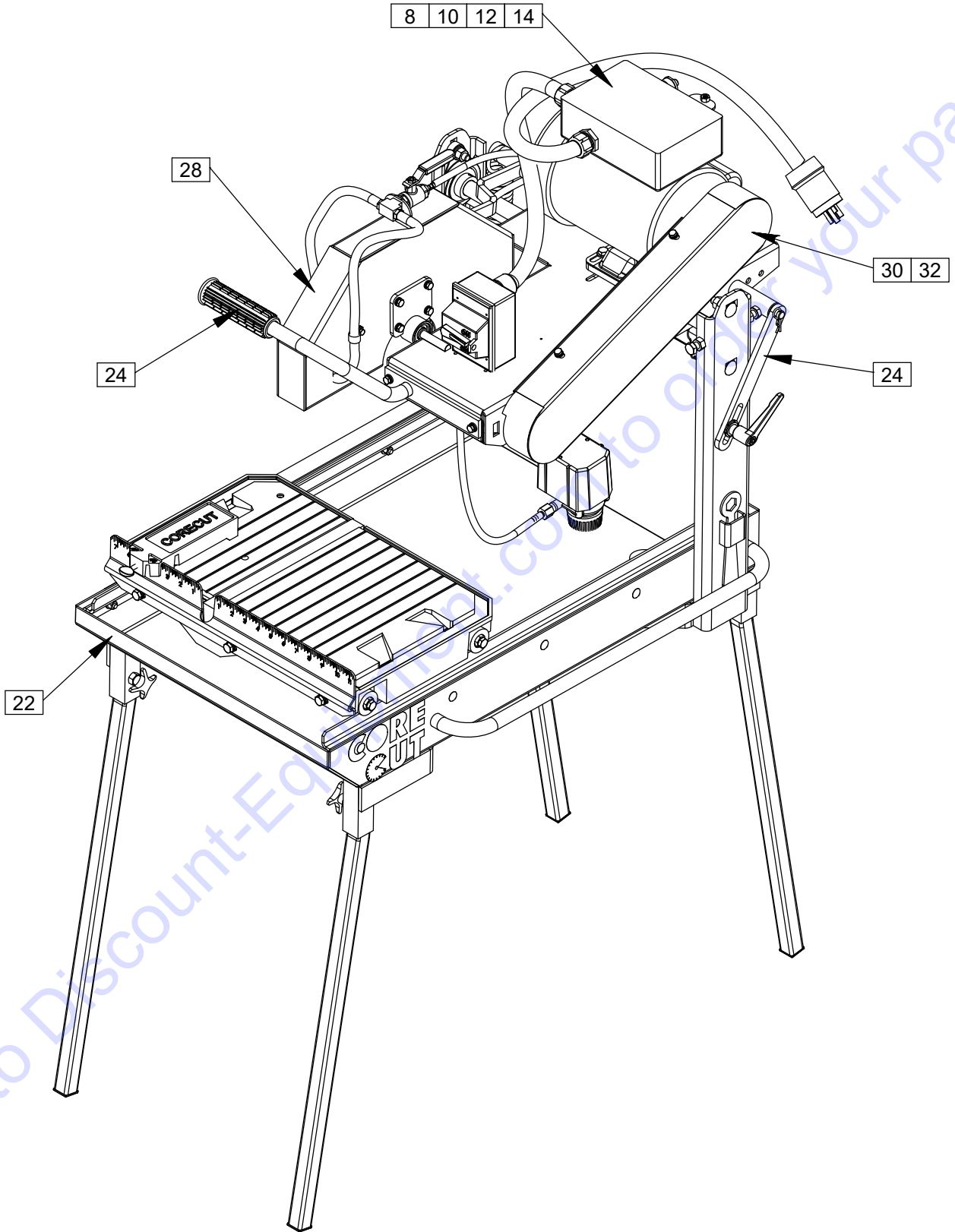

CC500MXL2 Electric Saw
Pictorial Page Index

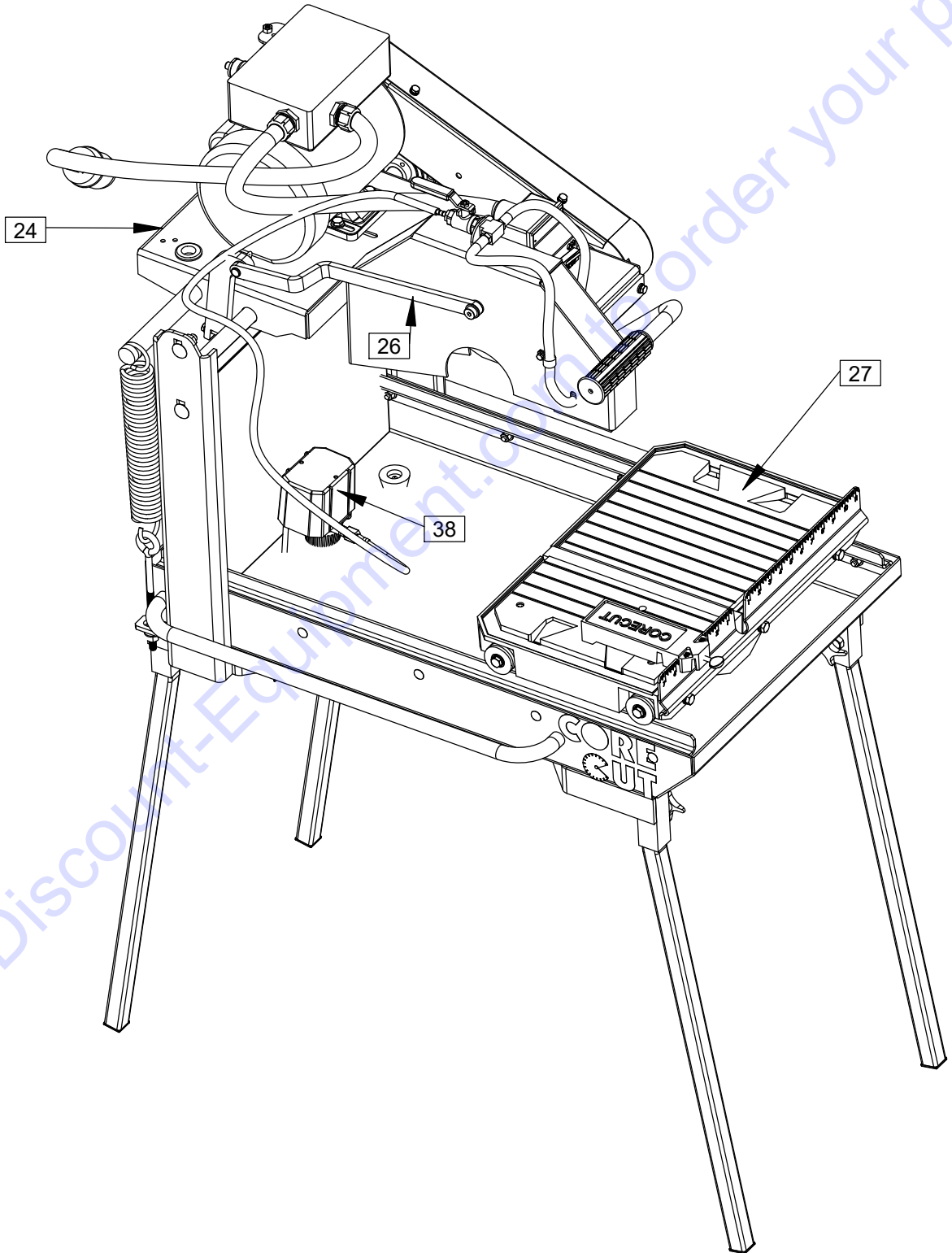

CC500M XL2 Gas Saw
Pictorial Page Index

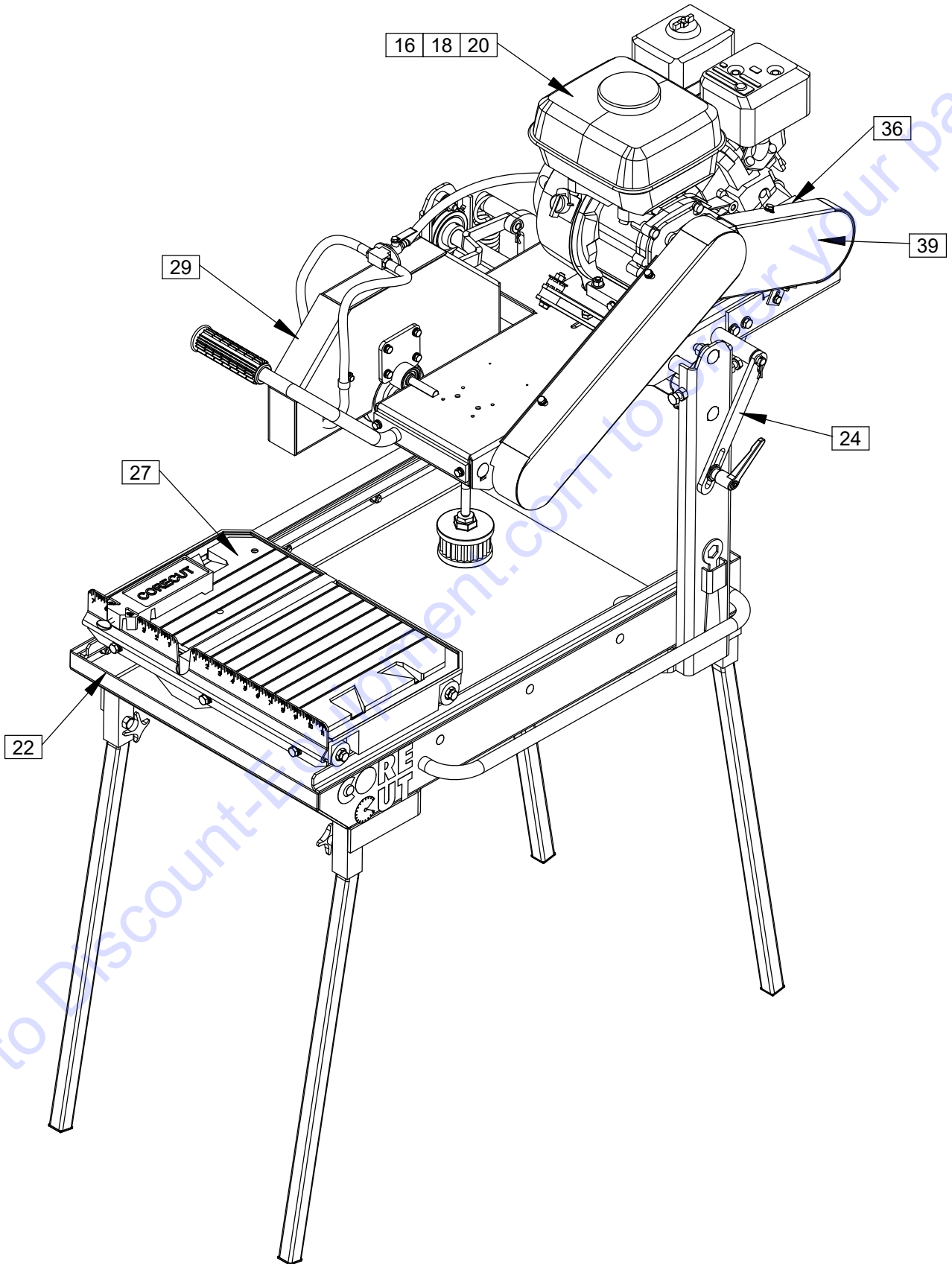

CC500MXL2 Gas Saw
Pictorial Page Index

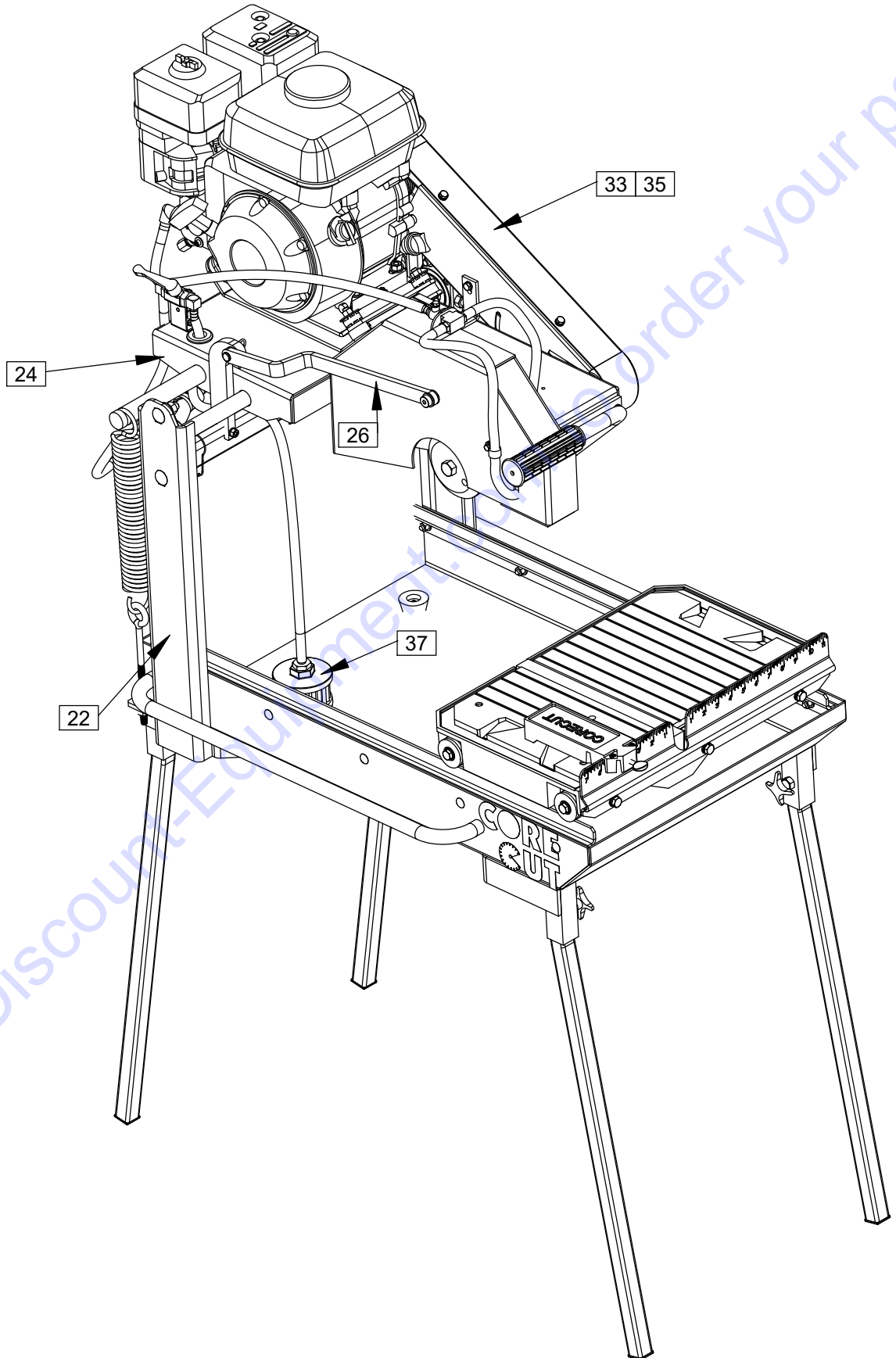

1.5 HP - 1 Phase Electric Motor Mount Assembly

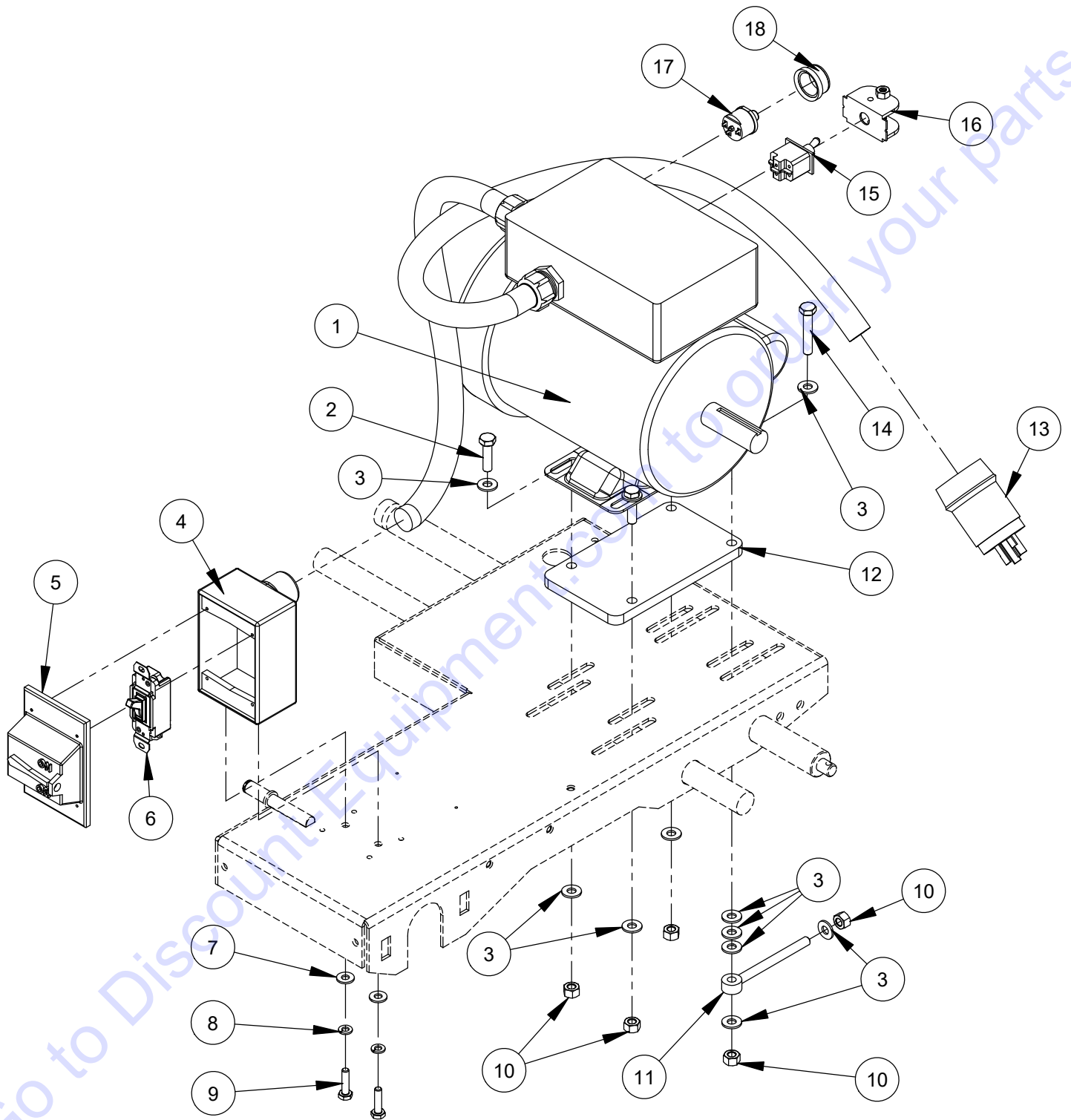

1.5 HP - 1 Phase Electric Motor Mount Assembly

ITEM	PART NO.	QTY.	DESCRIPTION
1	2600573	1	Baldor 1.5HP 115/230V Induction Motor
2	2900313	3	Cap Screw, Hex Hd., M8-1.25 x 30mm
3	2901583	12	M8 Washer (18mm OD)
4	2701762	1	Switch Box
5	2800309	1	Switch Box Lid W/Gaskets & Screws
6	2800232	1	Switch, On/ Off
7	2900009	2	Flat Washer, 1/4" SAE
8	2900024	2	Lock Washer, 1/4" Split
9	2900008	2	Cap Screw, Hex Hd., 1/4-20 x 1"
10	2900303	5	Lock Nut, M8-1.25 Nylon Insert
11	2902021	1	D18 x d8 - M8 x 1.25 x 87L Swing bolt
12	6030398	1	Motor Offset Mounting Plate
13	2800087	1	Plug, Nema L5-20P, 125VAC-20Amp
14	2900336	1	Cap Screw, Hex Hd., M8-1.25 x 45mm
15	2800159	1	Toggle Switch, DPDT, On/On
16	2704740	1	Guard for Voltage Switch
17	2800355	1	Thermal Overload Switch - 1.5 HP Baldor
18	2800354	1	Rubber Reset Cover

Go to Discount-Equipment.com to order your parts

2.0 HP - 1 Phase Electric Motor Mount Assembly

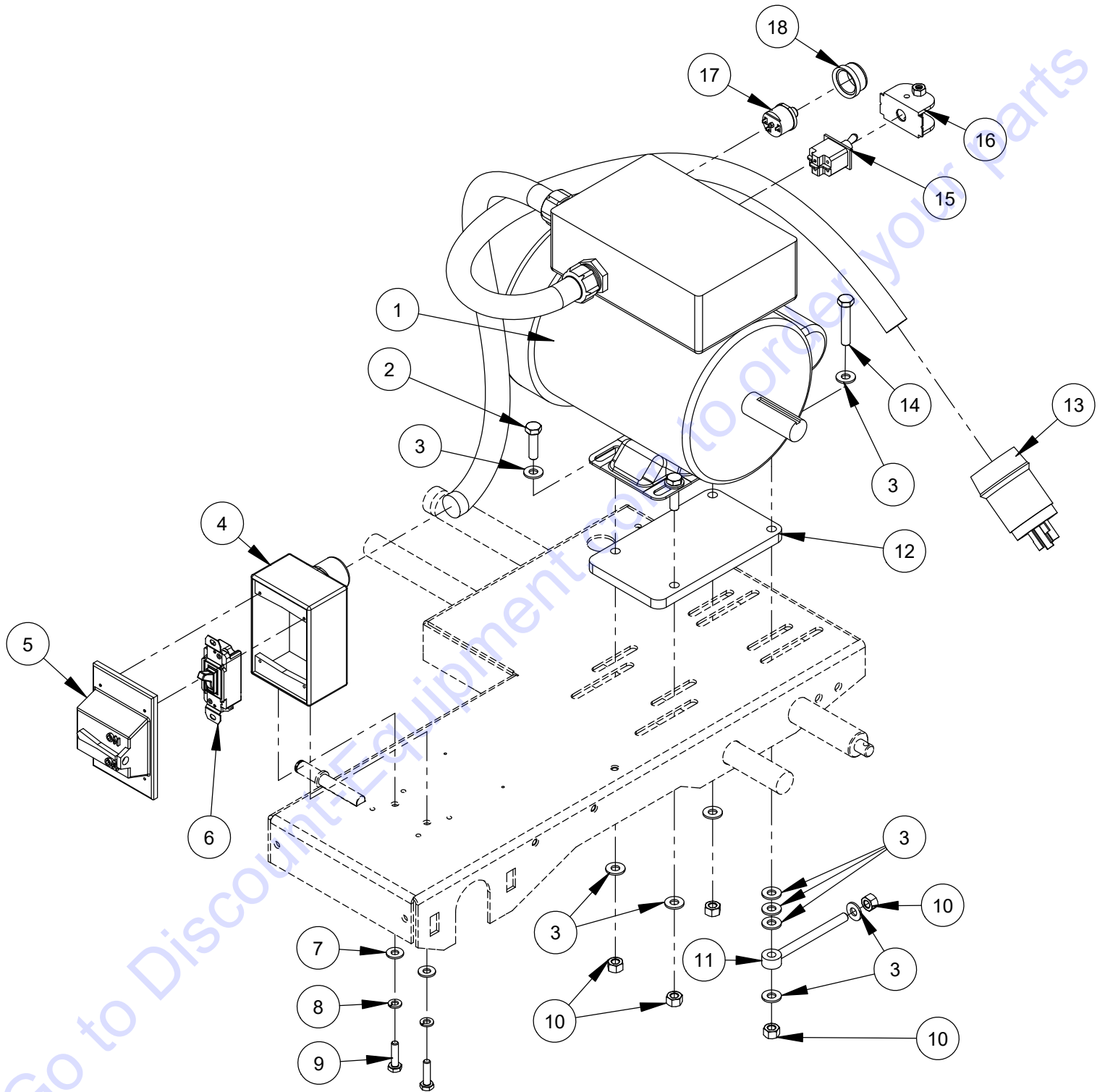

2.0 HP - 1 Phase Electric Motor Mount Assembly

ITEM	PART NO.	QTY.	DESCRIPTION
1	2600675	1	Baldor 2HP 1PH 115/230 Dual Voltage
2	2900313	3	Cap Screw, Hex Hd., M8-1.25 x 30mm
3	2901583	12	M8 Washer (18mm OD)
4	2701762	1	Switch Box
5	2800309	1	Switch Box Lid W/Gaskets & Screws
6	2800232	1	Switch, On/ Off
7	2900009	2	Flat Washer, 1/4" SAE
8	2900024	2	Lock Washer, 1/4" Split
9	2900008	2	Cap Screw, Hex Hd., 1/4-20 x 1"
10	2900303	5	Lock Nut, M8-1.25 Nylon Insert
11	2902021	1	D18 x d8 - M8 x 1.25 x 87L Swing bolt
12	6030398	1	Motor Offset Mounting Plate
13	2800087	1	Plug, Nema L5-20P, 125VAC-20Amp
14	2900336	1	Cap Screw, Hex Hd., M8-1.25 x 45mm
15	2800159	1	Toggle Switch, DPDT, On/On
16	2704740	1	Guard for Voltage Switch
17	2801027	1	Thermal Overload Switch - 2HP Baldor
18	2800354	1	Rubber Reset Cover

2.5HP - 1PH - Electric Motor Mount Assembly

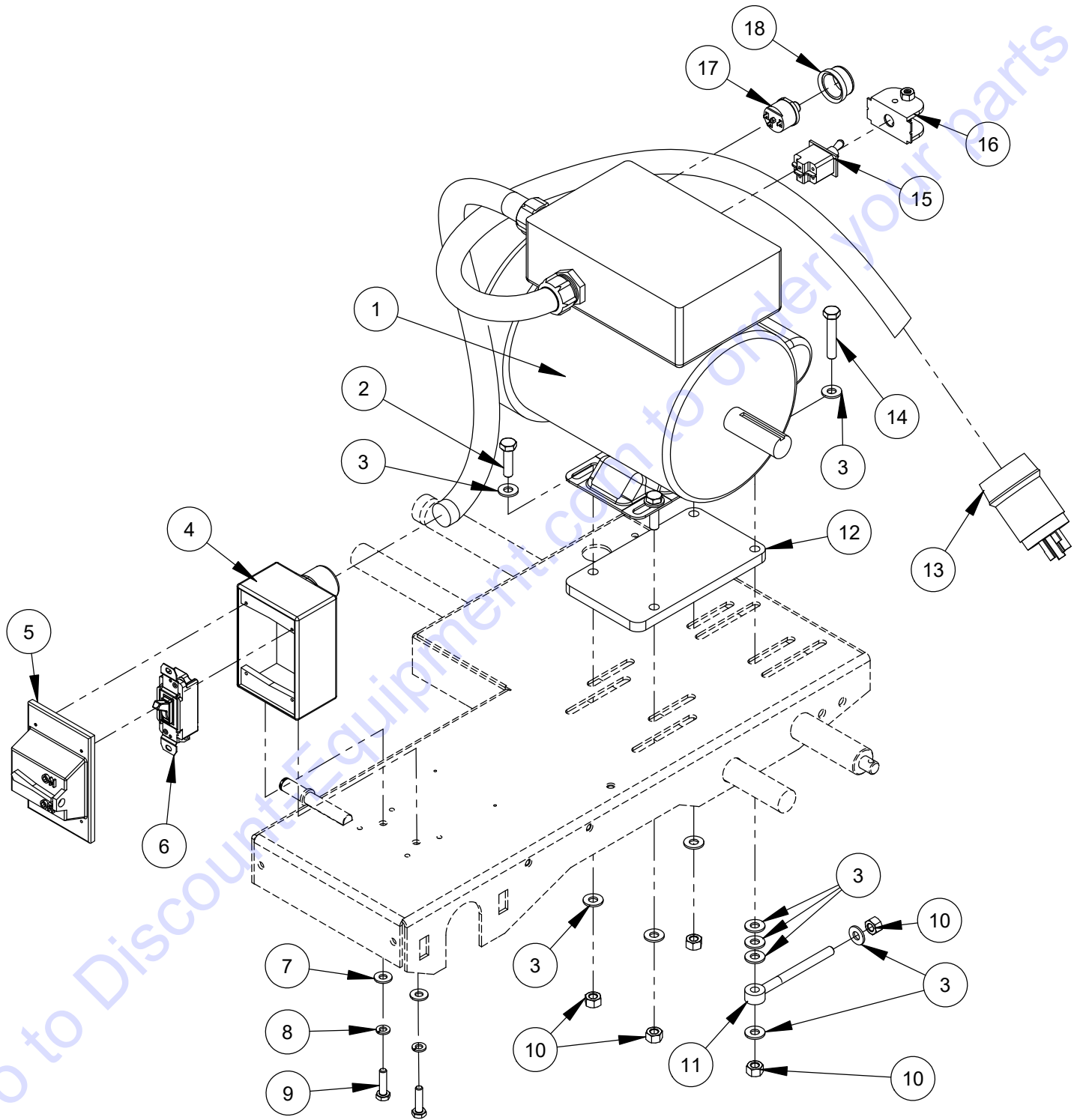

2.5HP - 1PH Electric Motor Mount Assembly

ITEM	PART NO.	QTY.	DESCRIPTION
1	2600574	1	Baldor 2.5HP 1PH 115/230V Induction Motor
2	2900313	3	Cap Screw, Hex Hd., M8-1.25 x 30mm
3	2901583	12	M8 Washer (18mm OD)
4	2701762	1	Switch Box
5	2800309	1	Switch Box Lid W/Gaskets & Screws
6	2800232	1	Switch, On/ Off
7	2900009	2	Flat Washer, 1/4" SAE
8	2900024	2	Lock Washer, 1/4" Split
9	2900008	2	Cap Screw, Hex Hd., 1/4-20 x 1"
10	2900303	5	Lock Nut, M8-1.25 Nylon Insert
11	2902021	1	D18 x d8 - M8 x 1.25 x 87L Swing bolt
12	6030398	1	Motor Offset Mounting Plate
13	2800087	1	Plug, Nema L5-20P, 125VAC-20Amp
14	2900336	1	Cap Screw, Hex Hd., M8-1.25 x 45mm
15	2800159	1	Toggle Switch, DPDT, On/On
16	2704740	1	Guard for Voltage Switch
17	2701650	1	Thermal Overload Switch - 2.5 HP Baldor
18	2800354	1	Rubber Reset Cover

3.0HP - 1 PH Electric Motor Mount Assembly
Counter Clockwise Rotation

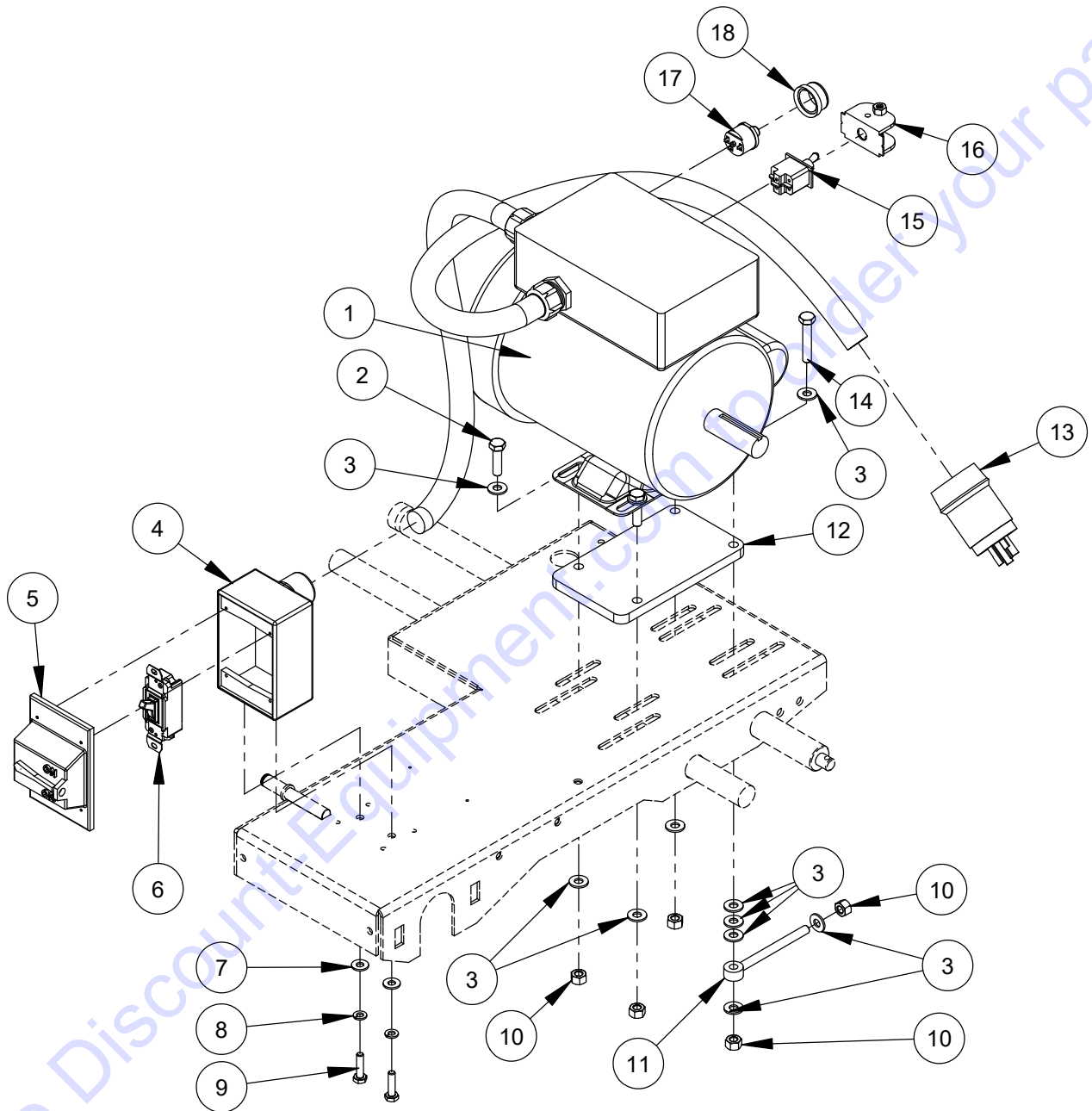

3.0HP - 1 PH Electric Motor Mount Assembly
Counter Clockwise Rotation

ITEM	PART NO.	QTY.	DESCRIPTION
1	2600575	1	Baldor 3HP 1PH 220V-50 CCW Rotation
2	2900313	3	Cap Screw, Hex Hd., M8-1.25 x 30mm
3	2901583	12	M8 Washer (18mm OD)
4	2701762	1	Switch Box
5	2800309	1	Switch Box Lid W/Gaskets & Screws
6	2800232	1	Switch, On/ Off
7	2900009	2	Flat Washer, 1/4" SAE
8	2900024	2	Lock Washer, 1/4" Split
9	2900008	2	Cap Screw, Hex Hd., 1/4-20 x 1"
10	2900303	5	Lock Nut, M8-1.25 Nylon Insert
11	2902021	1	D18 x d8 - M8 x 1.25 x 87L Swing bolt
12	6030398	1	Motor Offset Mounting Plate
13	2800087	1	Plug, Nema L5-20P, 125VAC-20Amp
14	2900336	1	Cap Screw, Hex Hd., M8-1.25 x 45mm
15	2800159	1	Toggle Switch, DPDT, On/On
16	2704740	1	Guard for Voltage Switch
17	2801028	1	Thermal Overload Switch - 3HP Baldor
18	2800354	1	Rubber Reset Cover

Go to Discounted Equipment Supply to order your parts

Honda 4.8HP Engine Assembly

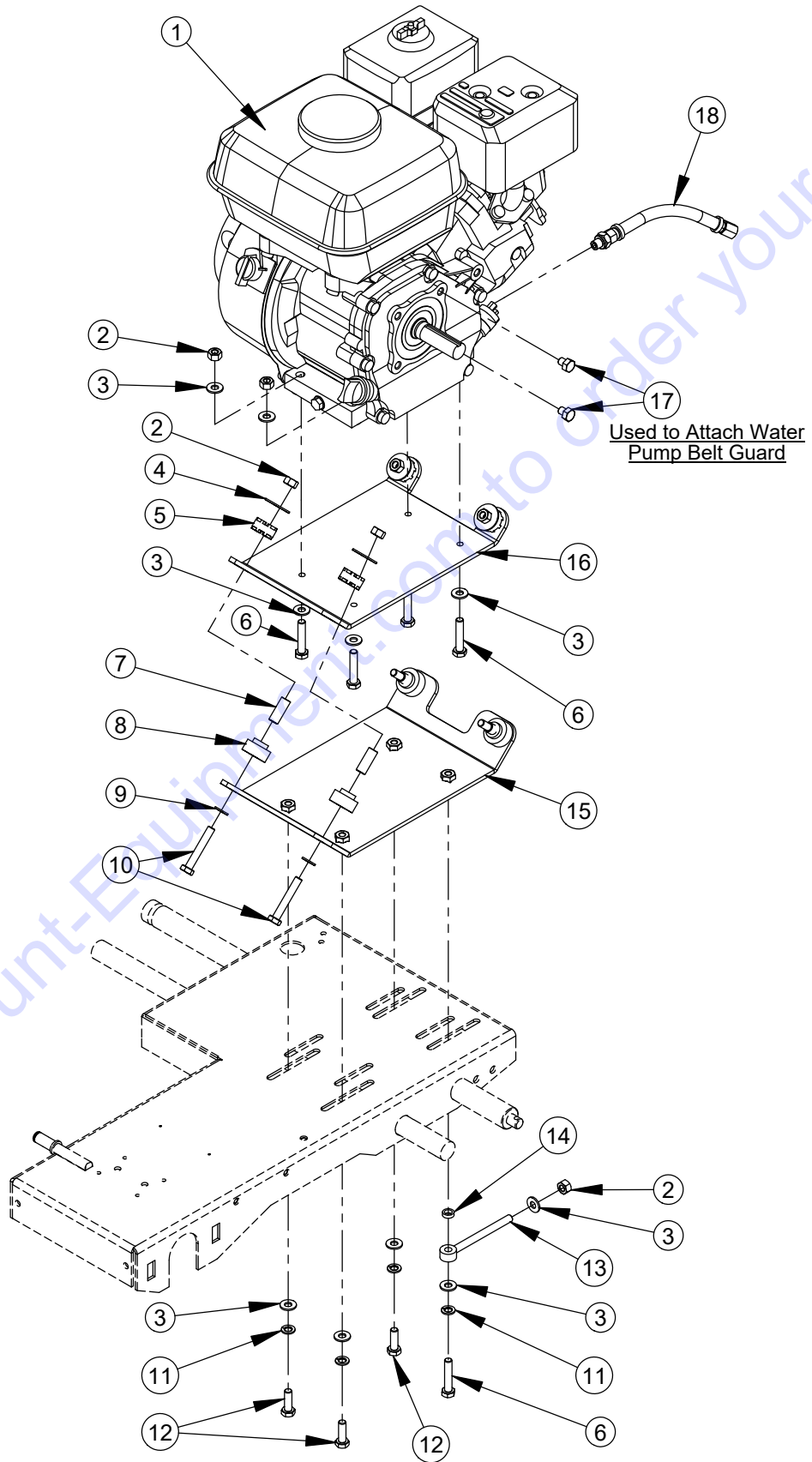

Honda 4.8HP Engine Assembly

ITEM	PART NO.	QTY.	DESCRIPTION
1	2600091	1	Honda GX160 4.8 HP Horizontal engine
2	2900303	9	Lock Nut, M8-1.25 Nylon Insert
3	2901583	13	M8 Washer (18mm OD)
4	2902025	4	Fender Washer 5/16 x 1.175 x 0.063"
5	2502149	4	Ring Bushing
6	2902024	5	Hex cap screw, M8 x 1.25 x 40L
7	6030278	4	Tube
8	2502151	4	Step Bushing
9	2901336	4	Flat Washer, M8
10	2907018	4	Cap Screw, Hex Hd., M8-1.25 x 50mm
11	2900763	4	Lock Washer, M8 Split
12	2900360	3	Cap Screw, Hex Hd., M8-1.25 x 25mm
13	2902022	1	D18 x d8 - M8 x 1.25 x 86L Swing bolt
14	6030475	1	Spacer, D12.5 x d8.5 x 4L
15	6030427	1	Vibration Damping Plate
16	6030426	1	Engine Mounting Plate
17	2900589	2	Cap Screw, Hex Hd., 5/16-24 x 3/4"
18	6030108	1	Oil Drain Assembly

Briggs 6.5HP Engine Assembly

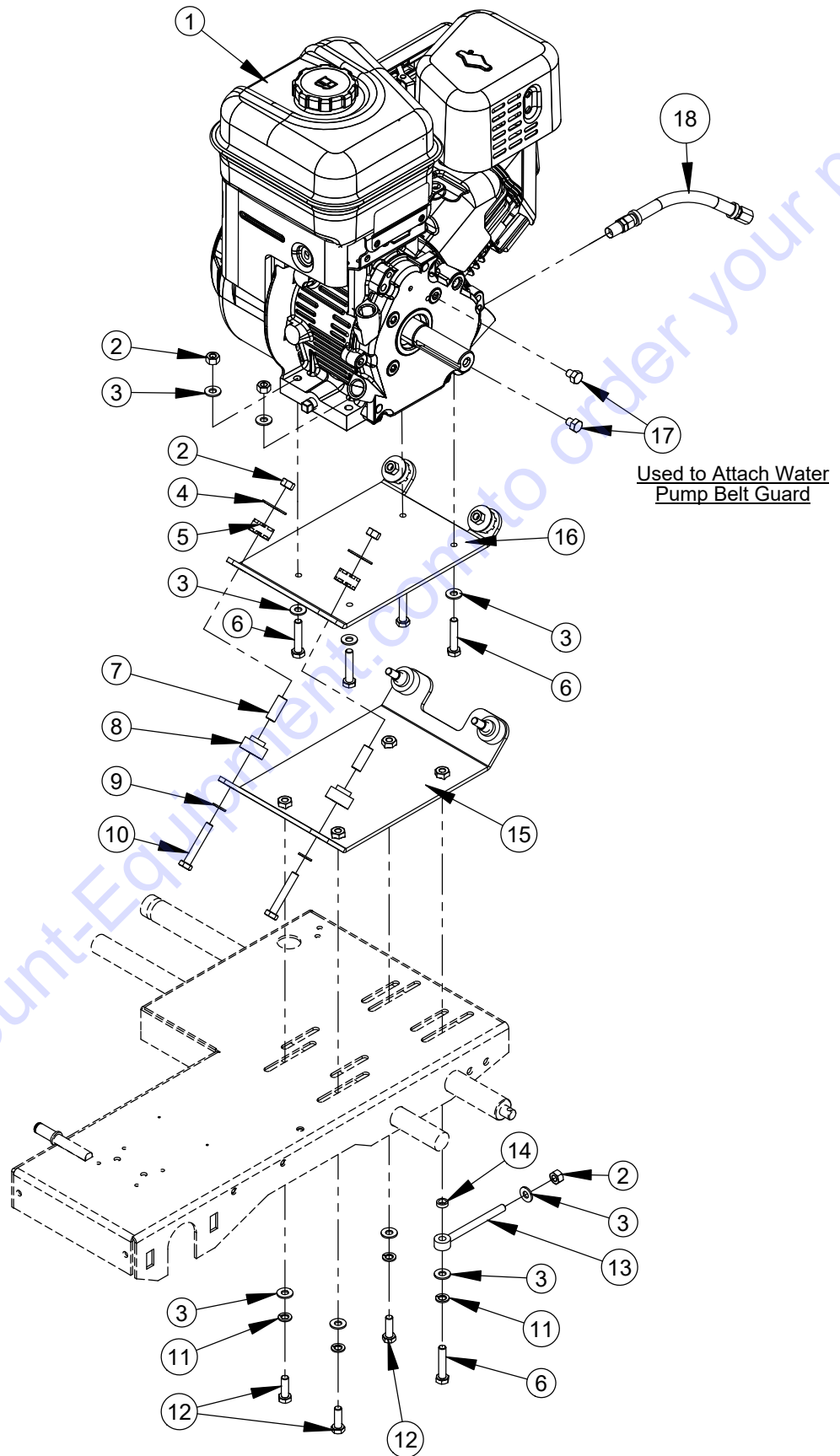

Briggs 6.5HP Engine Assembly

ITEM	PART NO.	QTY.	DESCRIPTION
1	2600601	1	Briggs 6.5HP Vanguard
2	2900303	9	Lock Nut, M8-1.25 Nylon Insert
3	2901583	13	M8 Washer (18mm OD)
4	2902025	4	Fender Washer 5/16 x 1.175 x 0.063"
5	2502149	4	Ring Bushing
6	2902024	5	Hex cap screw, M8 x 1.25 x 40L
7	6030278	4	Tube
8	2502151	4	Step Bushing
9	2901336	4	Flat Washer, M8
10	2907018	4	Cap Screw, Hex Hd., M8-1.25 x 50mm
11	2900763	4	Lock Washer, M8 Split
12	2900360	3	Cap Screw, Hex Hd., M8-1.25 x 25mm
13	2902022	1	D18 x d8 - M8 x 1.25 x 86L Swing bolt
14	6030475	1	Spacer, D12.5 x d8.5 x 4L
15	6030427	1	Vibration Damping Plate
16	6030426	1	Engine Mounting Plate
17	2900589	2	Cap Screw, Hex Hd., 5/16-24 x 3/4"
18	6030249	1	Oil Drain Assembly

Lifan 6.5HP Engine Assembly

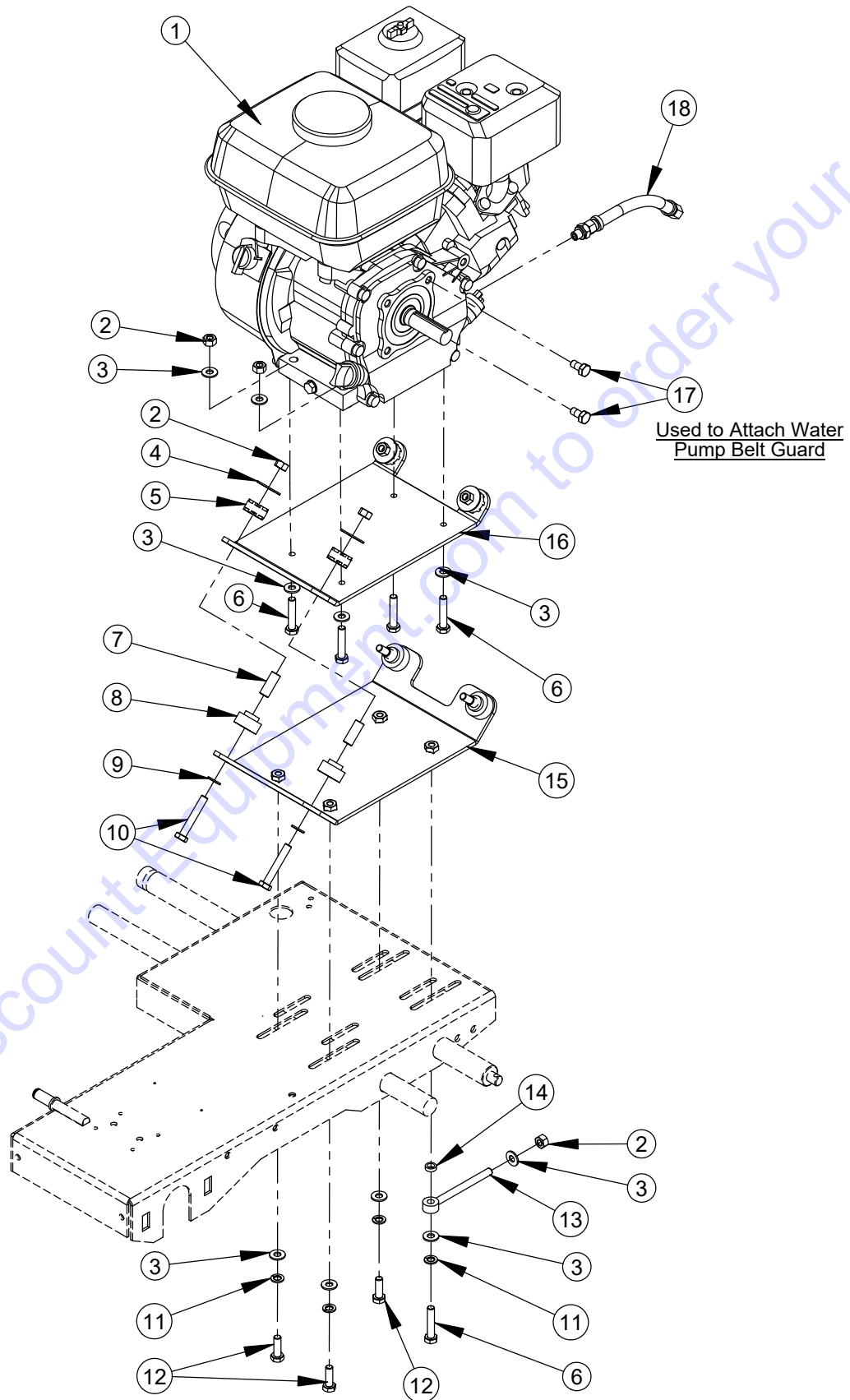

Lifan 6.5HP Engine Assembly

ITEM	PART NO.	QTY.	DESCRIPTION
1	2601708	1	Lifan 6.5HP Engine
2	2900303	9	Lock Nut, M8-1.25 Nylon Insert
3	2901583	13	M8 Washer (18mm OD)
4	2902025	4	Fender Washer 5/16 x 1.175 x 0.063"
5	2502149	4	Ring Bushing
6	2902024	5	Hex cap screw, M8 x 1.25 x 40L
7	6030278	4	Tube
8	2502151	4	Step Bushing
9	2901336	4	Flat Washer, M8
10	2907018	4	Cap Screw, Hex Hd., M8-1.25 x 50mm
11	2900763	4	Lock Washer, M8 Split
12	2900360	3	Cap Screw, Hex Hd., M8-1.25 x 25mm
13	2902022	1	D18 x d8 - M8 x 1.25 x 86L Swing bolt
14	6030475	1	Spacer, D12.5 x d8.5 x 4L
15	6030427	1	Vibration Damping Plate
16	6030426	1	Engine Mounting Plate
17	2900868	2	Cap Screw, Hex Hd., M8-1.25 x 16mm
18	6030108	1	Oil Drain Assembly

Frame Assembly

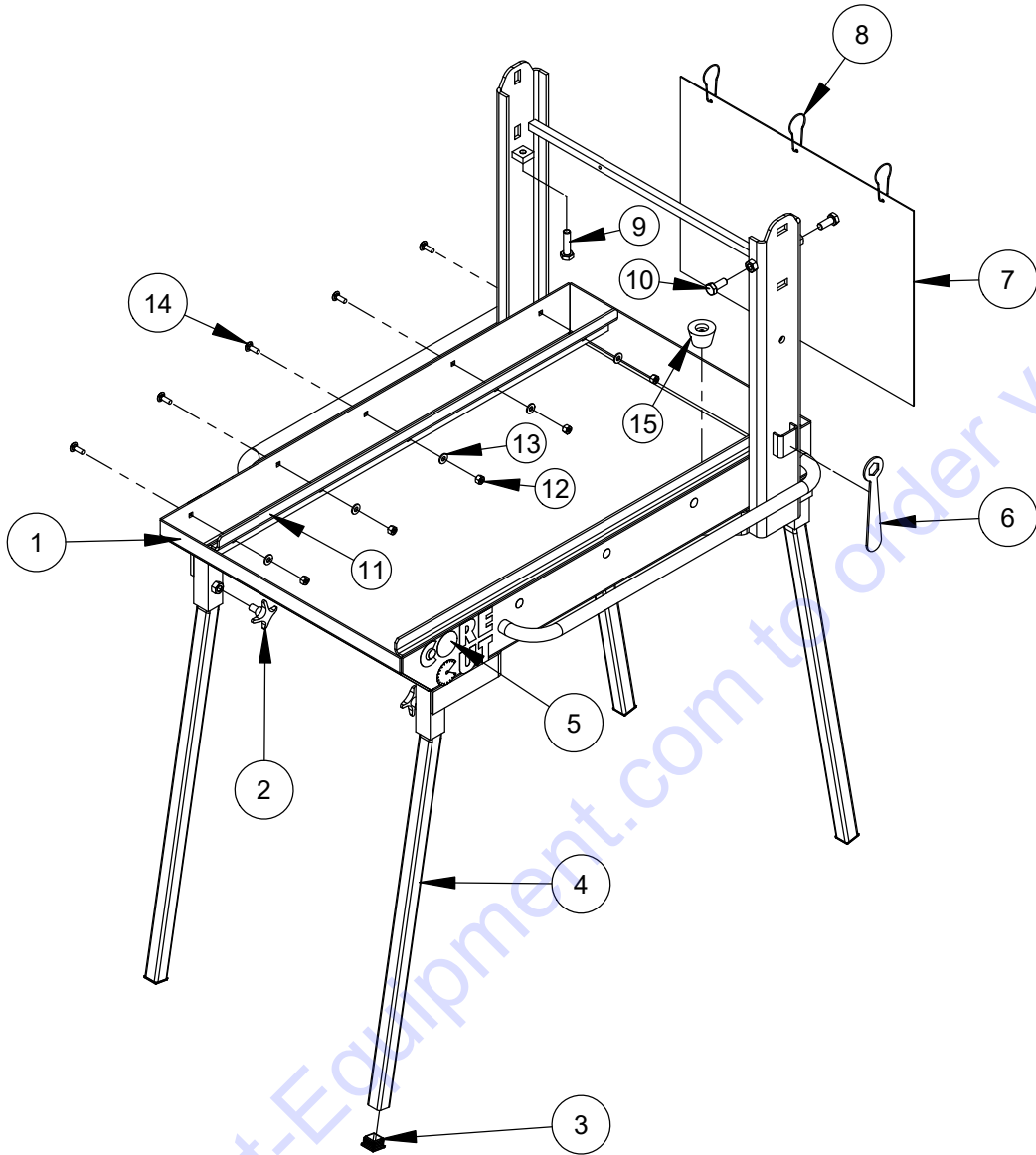

ITEM	PART NO.	QTY.	DESCRIPTION
1	6030395	1	Frame Weldment
2	2907007	4	M10 x 15L Knob
3	2506354	4	25mm Square tube cap
4	6030423	4	Leg
5	1800506	2	Core Cut Decal
6	6030021	1	Hex Wrench, 3/4"
7	6030030	1	Splash Curtain
8	2500816	3	Curtain Ring, 1"
9	2900799	1	Cap Screw, Hex Hd., M10-1.25 x 40mm
10	2900333	2	Cap Screw, Hex Hd., M10-1.5 x 25mm
11	6030404	2	Frame Rails CC500MXL2
12	2900010	10	Lock Nut, 1/4-20 Nylon
13	2900009	10	Flat Washer, 1/4" SAE
14	2900591	10	RHSNBOLT 0.25-20 X 0.75-N
15	6043052	1	Drain Plug with Chain

Upper Frame - Head Weldment Assembly

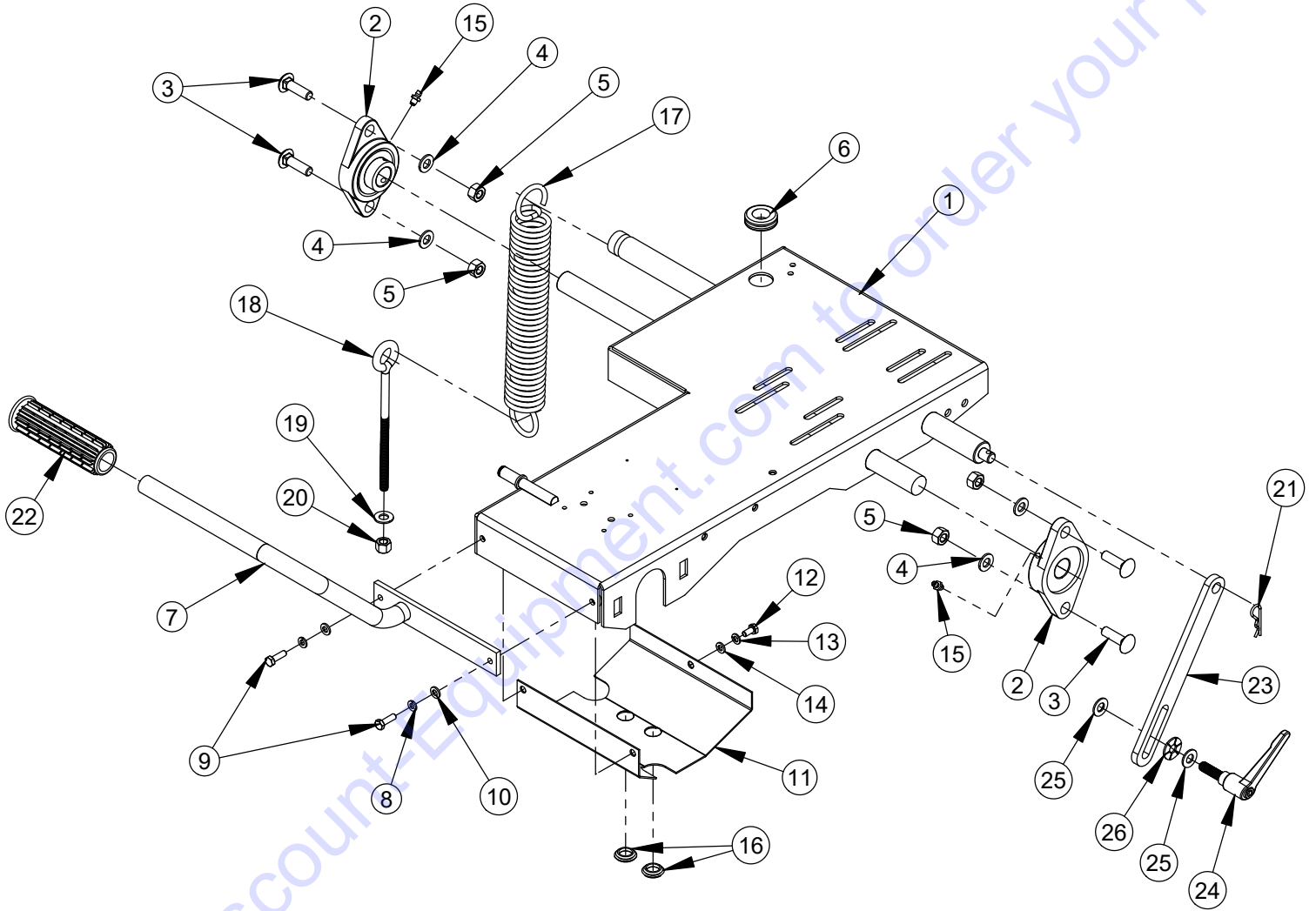

Upper Frame - Head Weldment Assembly

ITEM	PART NO.	QTY.	DESCRIPTION
1	6030406	1	Cutting head mounting plate
2	2500575	2	Flange Block Bearing, 7/8"
3	2900372	4	Carriage Bolt M10 x 35
4	2901356	4	Flat Washer, M10
5	2900304	4	Lock Nut, M10-1.5 Nylon Insert
6	2500203	1	Grommet, 3/4" I.D.
7	6091205	1	Cutting Head Plunge Handle Assembly
8	2907014	2	M6 Washer, Lock
9	2900310	2	Cap Screw, Hex Hd., M6-1.0 x 20mm
10	2907011	2	M6 Washer, Narrow
11	6030419	1	Blade Shaft Cover Weldment
12	2900544	1	Cap Screw, Hex Hd., M6-1.0 x 12mm
13	2900765	1	Lock Washer, M6 Split
14	2901494	1	Flat Washer, M6
15	2900706	2	Grease Zerk, 1/4-28 Straight
16	2506356	2	18mm End cap
17	2500559	1	Lee Spring LE-031 D8
18	2900602	1	Eye Bolt, 3/8-16 x 6"
19	2900014	1	Flat Washer, 3/8" SAE
20	2900018	1	Locknut, 3/8-16, Nylon
21	2900262	1	Hairpin Cotter
22	2500001	1	7/8" Handle Grip

Depth Lock #6053541

ITEM	PART NO.	QTY.	DESCRIPTION
23	6030269	1	Depth Lock
24	2504589	1	M10 x 1.5 x 32mm Adjustable Handle
25	2900014	2	Flat Washer, 3/8" SAE
26	2902016	1	3/8 Waved Lock Washer

Leveling Arm Assembly

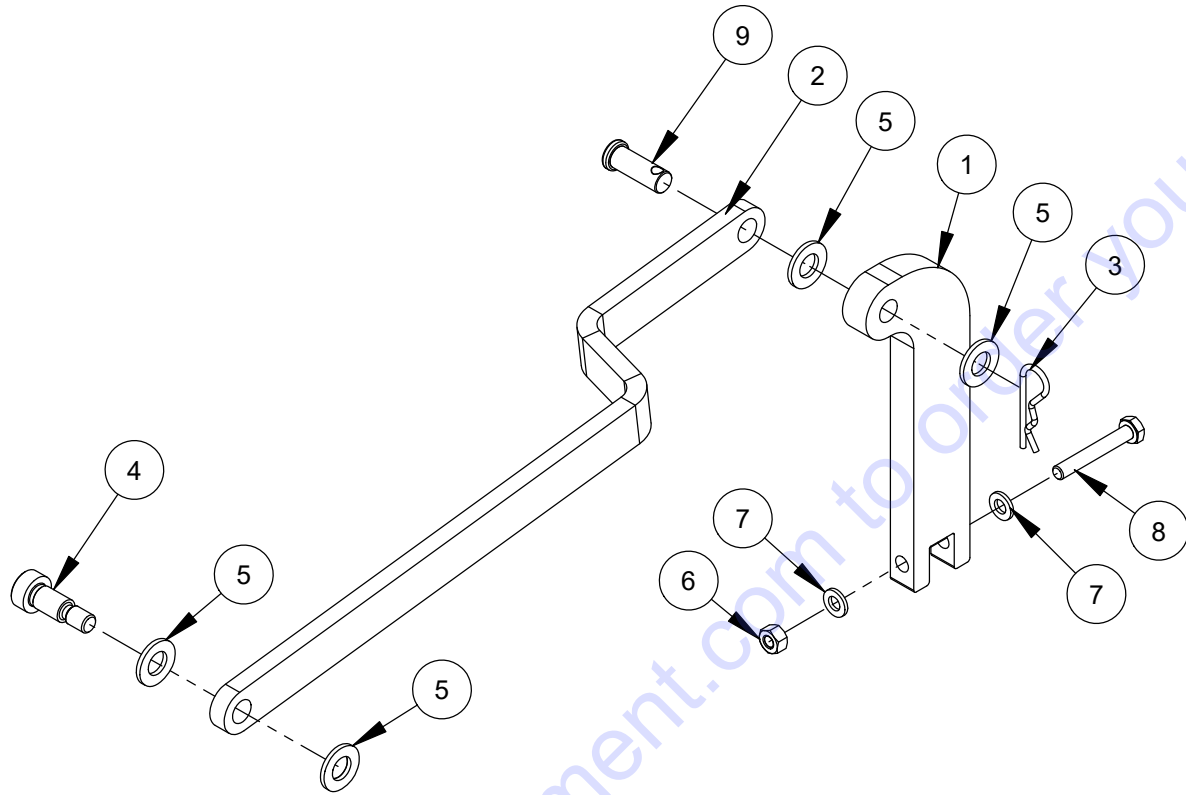

ITEM	PART NO.	QTY.	DESCRIPTION
1	6030271	1	Leveling Bracket
2	6030422	1	Leveling Arm
3	2900262	1	Hairpin Cotter
4	2907016	1	8mm X 10mm Shoulder Screw
5	2901356	4	Flat Washer, M10
6	2900302	1	Lock Nut, M6-1.0 Nylon Insert
7	2901494	2	Flat Washer, M6
8	2907012	1	Cap Screw, Hex Hd., M6-1.0 x 40mm
9	2900600	1	Clevis Pin, 3/8" Dia. x 1"

Conveyor Cart - #6030443

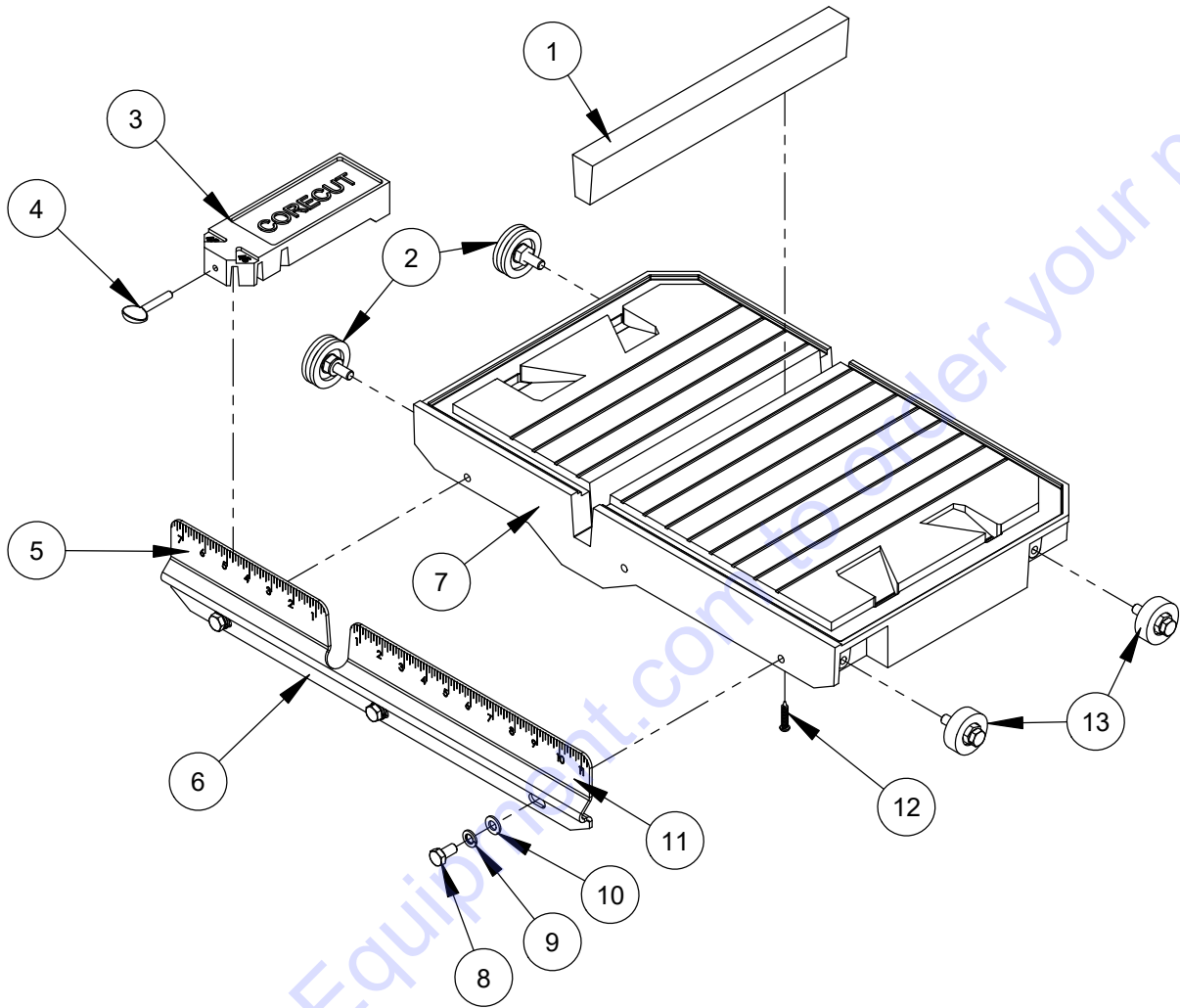

ITEM	PART NO.	QTY.	DESCRIPTION
1	6030413	1	Cart Insert
2	6030409	2	Guide Roller Assembly
3	6030022	1	Rip Guide (Tapped) Block Saw
4	2900540	1	Thumb Screw, M6 X 30mm
5	2500659	1	Rule, Adhesive 12" L-R
6	6030408	1	Measuring Stop
7	6030407	1	Conveyor Cart Cast with Injected Rubber
8	2900868	3	Cap Screw, Hex Hd., M8-1.25 x 16mm
9	2900763	3	Lock Washer, M8 Split
10	2901336	3	Flat Washer, M8
11	2500660	1	Rule, Adhesive 12" R-L
12	2900070	2	Wood Screw, #8 X 1.00"
13	6030410	2	Type 10 Flat Roller Assembly

Blade Guard Assembly - Electric

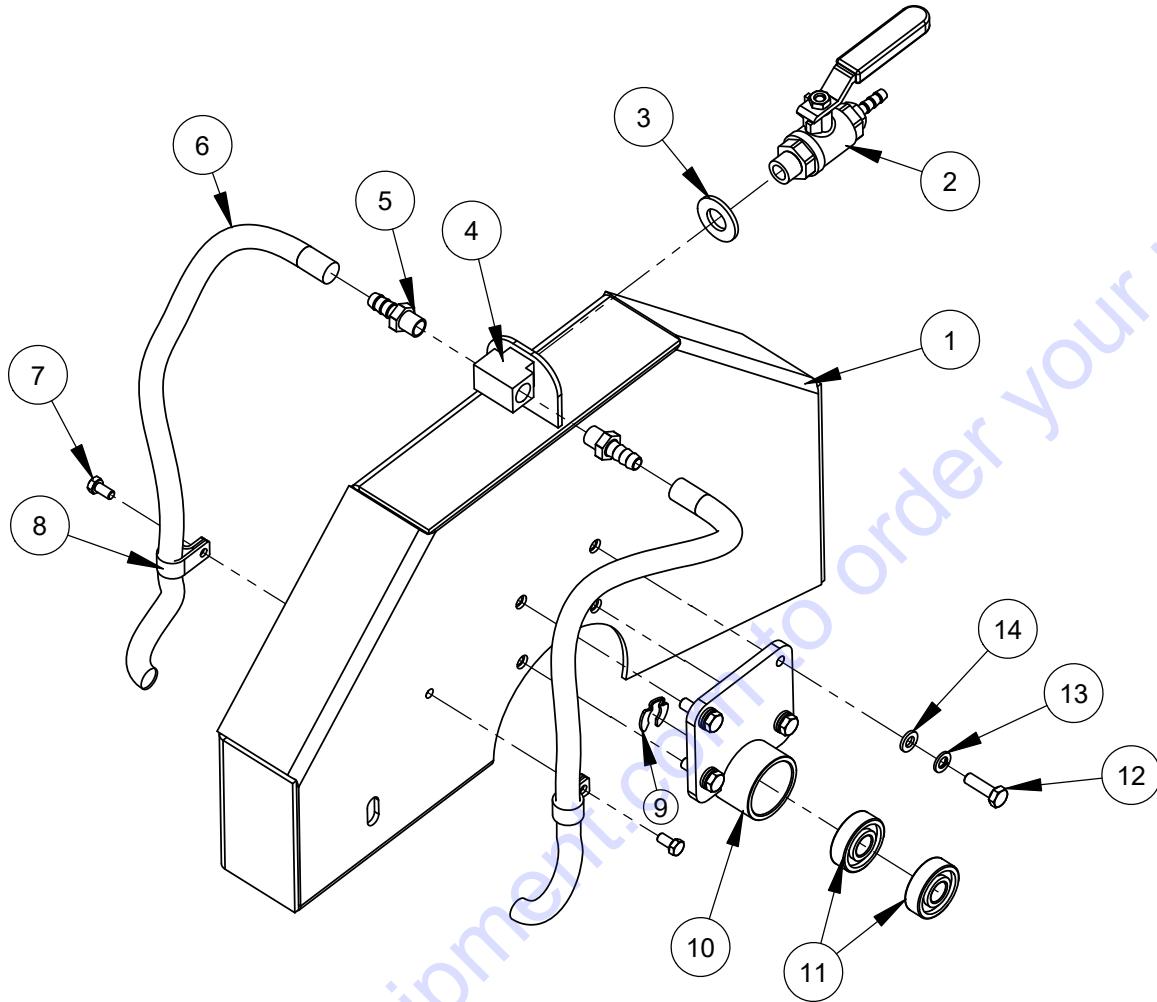

ITEM	PART NO.	QTY.	DESCRIPTION
1	6030405	1	Blade Guard Weldment
2	6015135	1	Male 1/4" PT to 5/16" Barbed Valve Fitting
3	2900058	1	Flat Washer, 1/2" SAE
4	3202095	1	1/4 PT T-Shape Female Connector
5	3202094	2	Male 1/4 PT to barbed 5/16" adapter
6	3203004	2	8mm x 12mm x 330L Water Hose
7	2902019	2	B18.2.3.1M - Hex cap screw, M5 x 0.8 x 10 --10N
8	3204611	2	Clamp, 1/2" Black Nylon
9	2502165	1	1/2" Heavy Duty E-Style Retaining Clip
10	6030273	1	Bearing Housing Weldment
11	2502162	2	12 X 10 X 32mm Bearing
12	2900310	4	Cap Screw, Hex Hd., M6-1.0 x 20mm
13	2900765	4	Lock Washer, M6 Split
14	2901494	4	Flat Washer, M6

Blade Guard Assembly - Gas

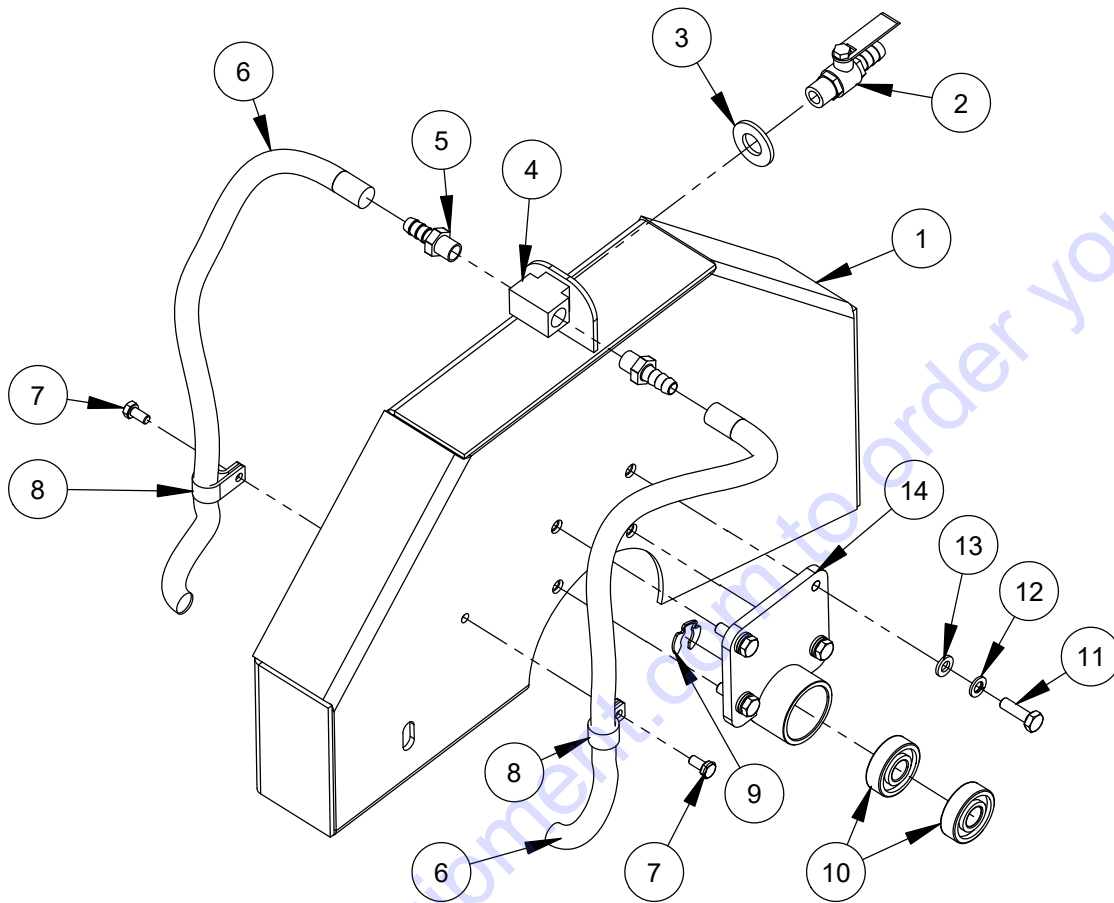

ITEM	PART NO.	QTY.	DESCRIPTION
1	6030405	1	Blade Guard Weldment
2	3204211	1	Male 1/4 PT to barbed 3/8" straight valve fitting
3	2900058	1	Flat Washer, 1/2" SAE
4	3202095	1	1/4 PT T-Shape Female Connector
5	3202094	2	Male 1/4 PT to barbed 5/16" adapter
6	3203004	2	8mm x 12mm x 330L Water Hose
7	2902019	2	B18.2.3.1M - Hex cap screw, M5 x 0.8 x 10 --10N
8	3204611	2	Clamp, 1/2" Black Nylon
9	2502165	1	1/2" Heavy Duty E-Style Retaining Clip
10	2502162	2	12 X 10 X 32mm Bearing
11	2900310	4	Cap Screw, Hex Hd., M6-1.0 x 20mm
12	2900765	4	Lock Washer, M6 Split
13	2901494	4	Flat Washer, M6
14	6030273	1	Bearing Housing Weldment

Blade Shaft Assembly - Electric

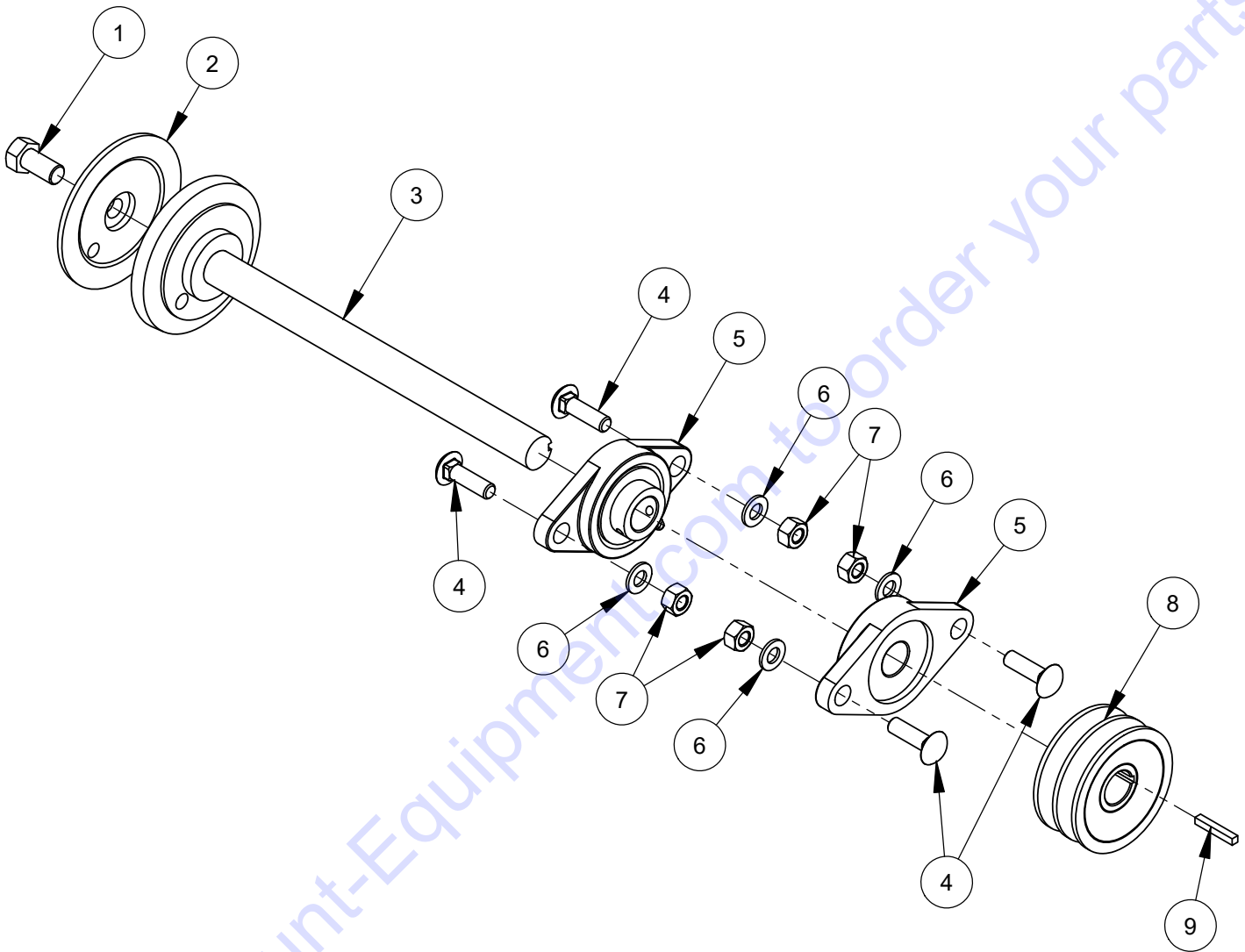

ITEM	PART NO.	QTY.	DESCRIPTION
1	2900539	1	Cap Screw, Hex Hd., 1/2-20 x 1" LH
2	6030313	1	Outer Flange, 4" w/o Pin
3	6030097	1	Bladeshaft w/ Inner Flange LH
4	2900372	4	Carriage Bolt M10 x 35
5	2500575	2	Flange Block Bearing, 7/8"
6	2901356	4	Flat Washer, M10
7	2900304	4	Lock Nut, M10-1.5 Nylon Insert
8	2500640	1	Pulley, 2AK30 - 7/8"
9	6048229	1	Key, 3/16" Sq. x 1-1/4"

Blade Shaft Assembly- Gas

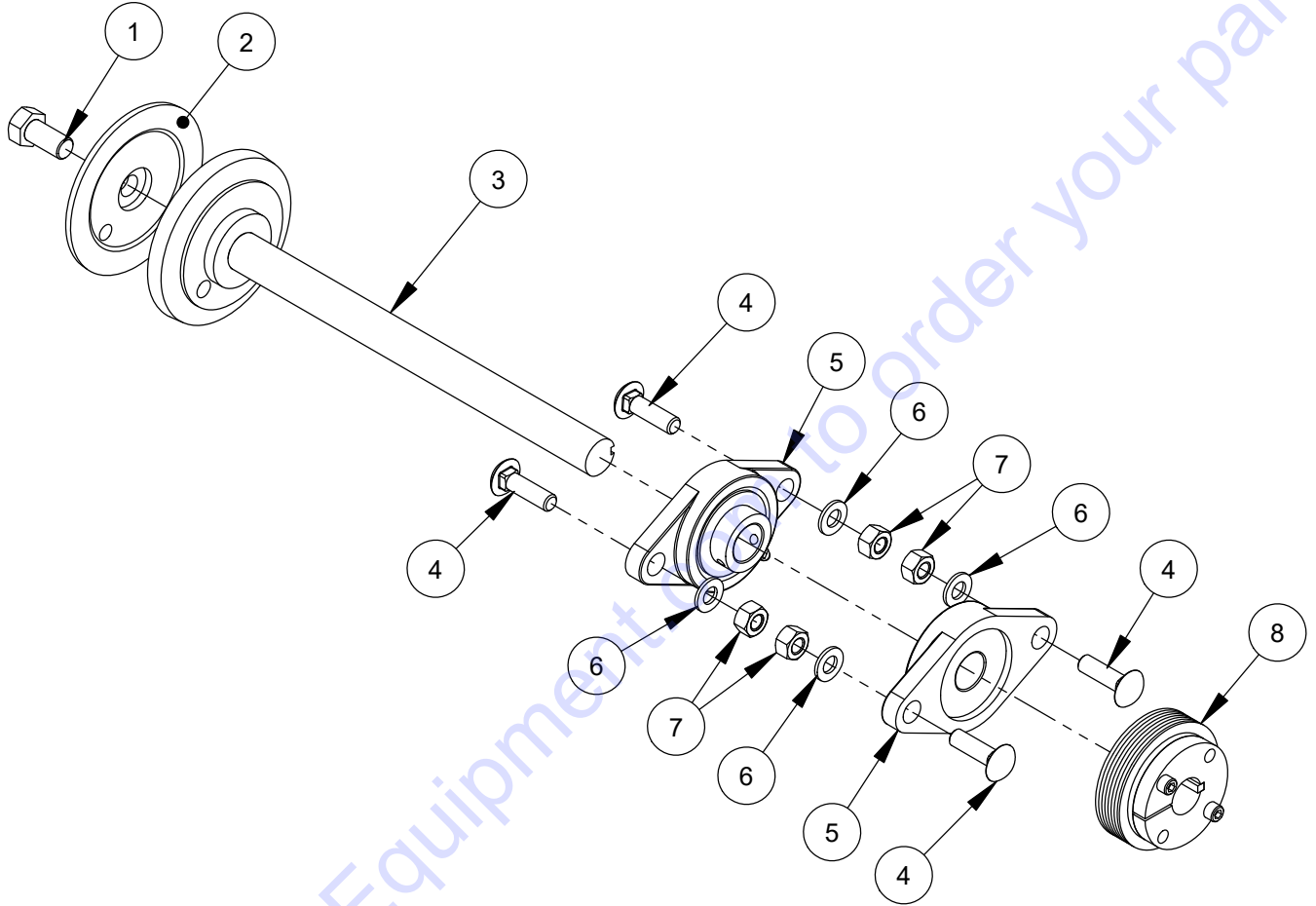

ITEM	PART NO.	QTY.	DESCRIPTION
1	2900539	1	Cap Screw, Hex Hd., 1/2-20 x 1" LH
2	6030313	1	Outer Flange, 4" w/o Pin
3	6030097	1	Bladeshaft w/ Inner Flange LH
4	2900372	4	Carriage Bolt M10 x 35
5	2500575	2	Flange Block Bearing, 7/8"
6	2901356	4	Flat Washer, M10
7	2900304	4	Lock Nut, M10-1.5 Nylon Insert
8	2505431	1	Ribbed J Pulley (40mm) and Bushing (22.2mm)

Belt Guard Assembly
(Electric Models Only)

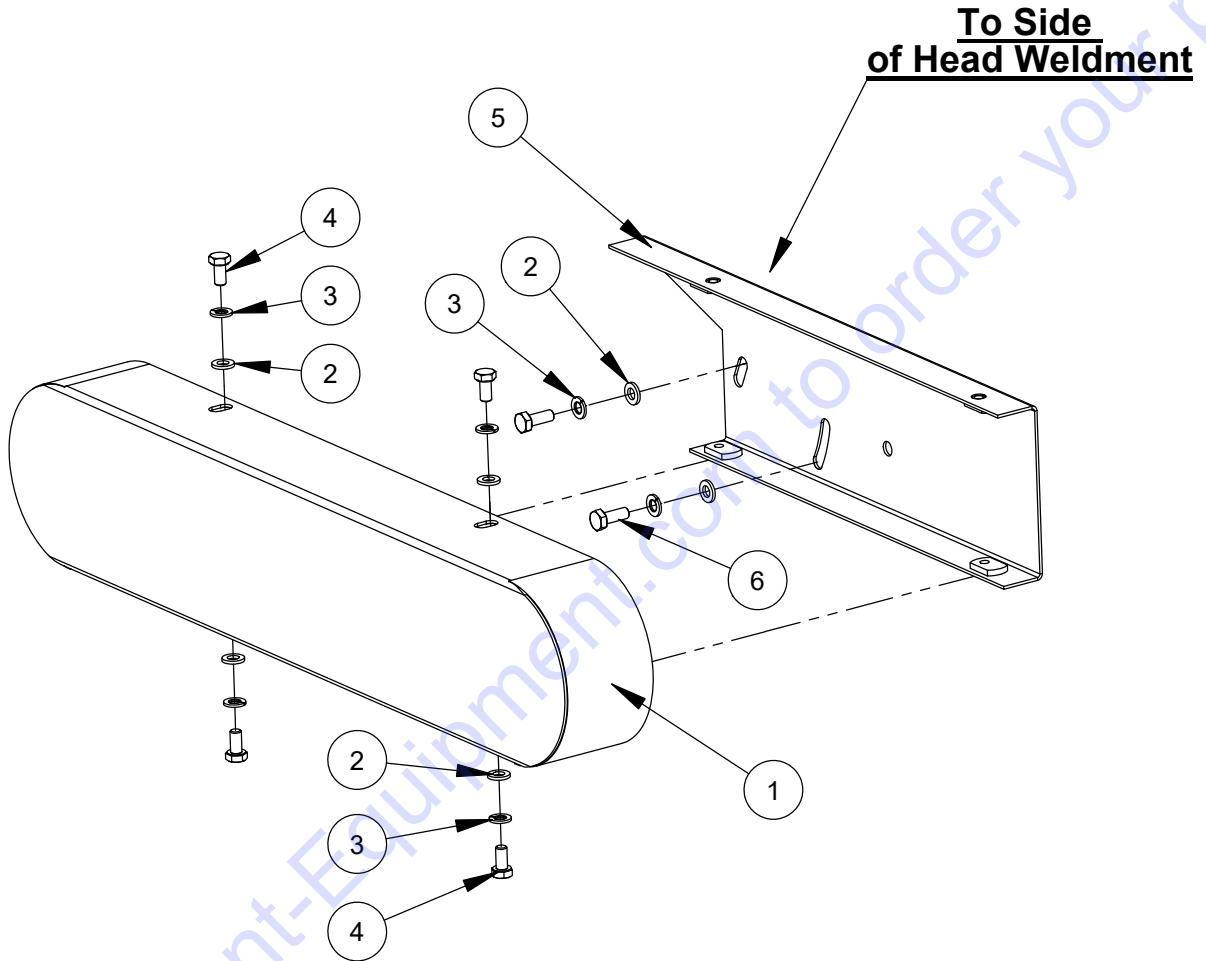

ITEM	PART NO.	QTY.	DESCRIPTION
1	6030416	1	Belt Guard, Electric
2	2901494	6	Flat Washer, M6
3	2900765	6	Lock Washer, M6 Split
4	2900544	4	Cap Screw, Hex Hd., M6-1.0 x 12mm
5	6030401	1	Belt guard mounting bracket
6	2900341	2	Cap Screw, Hex Hd., M6-1.0 x 16mm

Belt Guard Assembly (Gas Models Only)

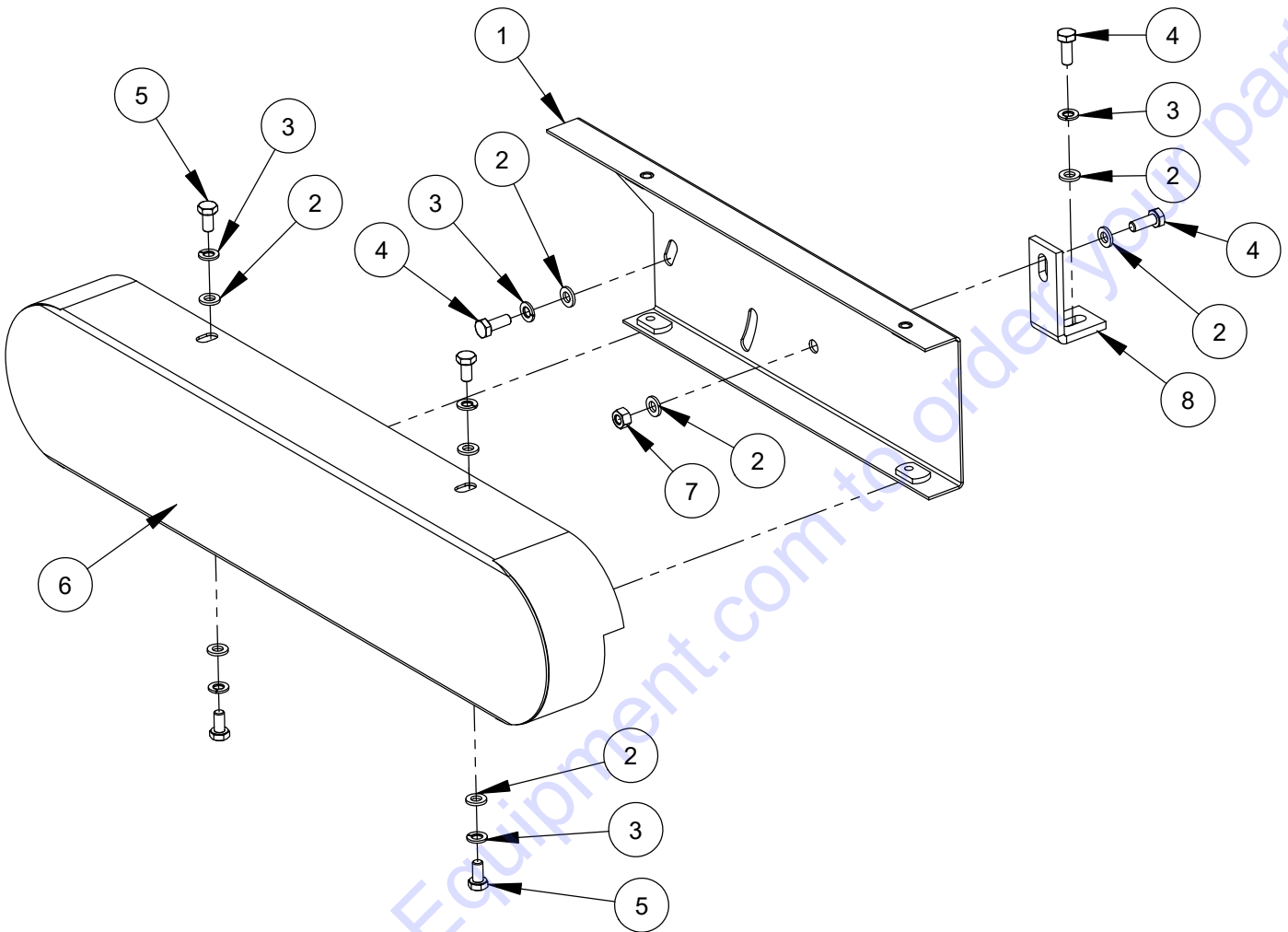

ITEM	PART NO.	QTY.	DESCRIPTION
1	6030401	1	Belt guard mounting bracket
2	2901494	8	Flat Washer, M6
3	2900765	6	Lock Washer, M6 Split
4	2900341	3	Cap Screw, Hex Hd., M6-1.0 x 16mm
5	2900544	4	Cap Screw, Hex Hd., M6-1.0 x 12mm
6	6030417	1	Belt Guard -Gas
7	2900302	1	Lock Nut, M6-1.0 Nylon Insert
8	6047716	1	Belt Guard Brace

Electric Motor Belt Drive Assembly

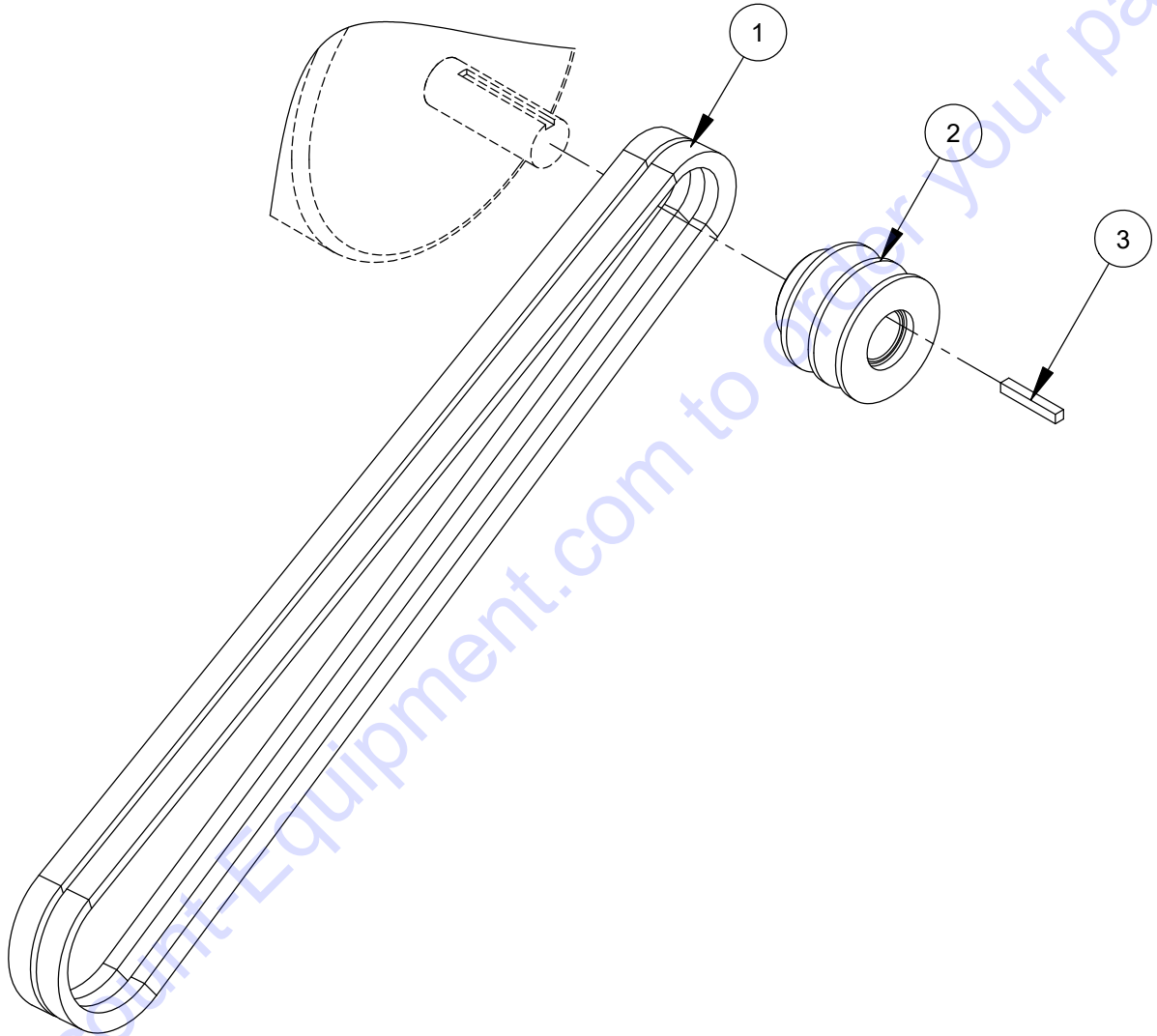

ITEM	PART NO.	QTY.	DESCRIPTION
1	2500032	2	V-Belt 4L-390
2	2500639	1	Pulley, 2AK22 X 7/8"
3	6048229	1	Key, 3/16" Sq. x 1-1/4"

Gas Engine Belt Drive

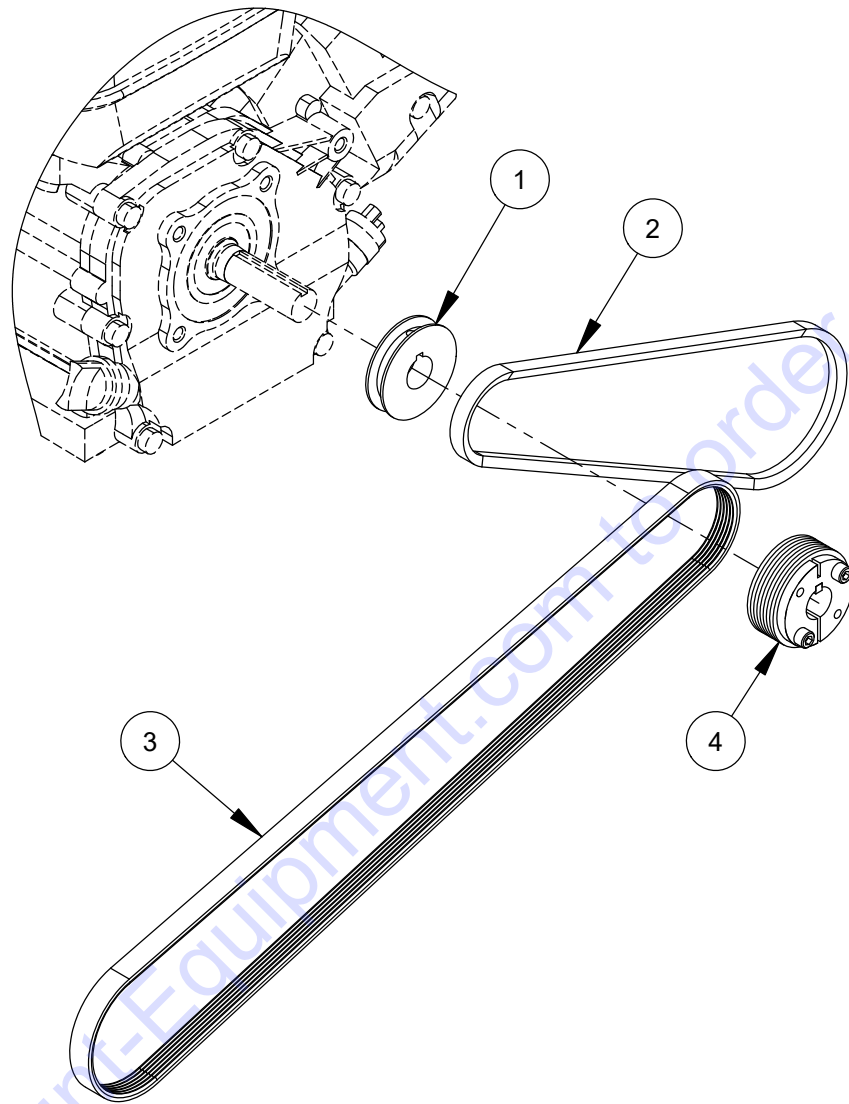

ITEM	PART NO.	QTY.	DESCRIPTION
1	2500921	1	Pulley, 3L-2.17-1G X 3/4"
2	2506476	1	V-Belt 3L-290
3	2500683	1	Poly V-Belt, 400J6
4	2505424	1	34MM Bore 6 ribbed J pulley and 19.1MM Bore QD Bushing

Diaphragm Pump Assembly Gas Model

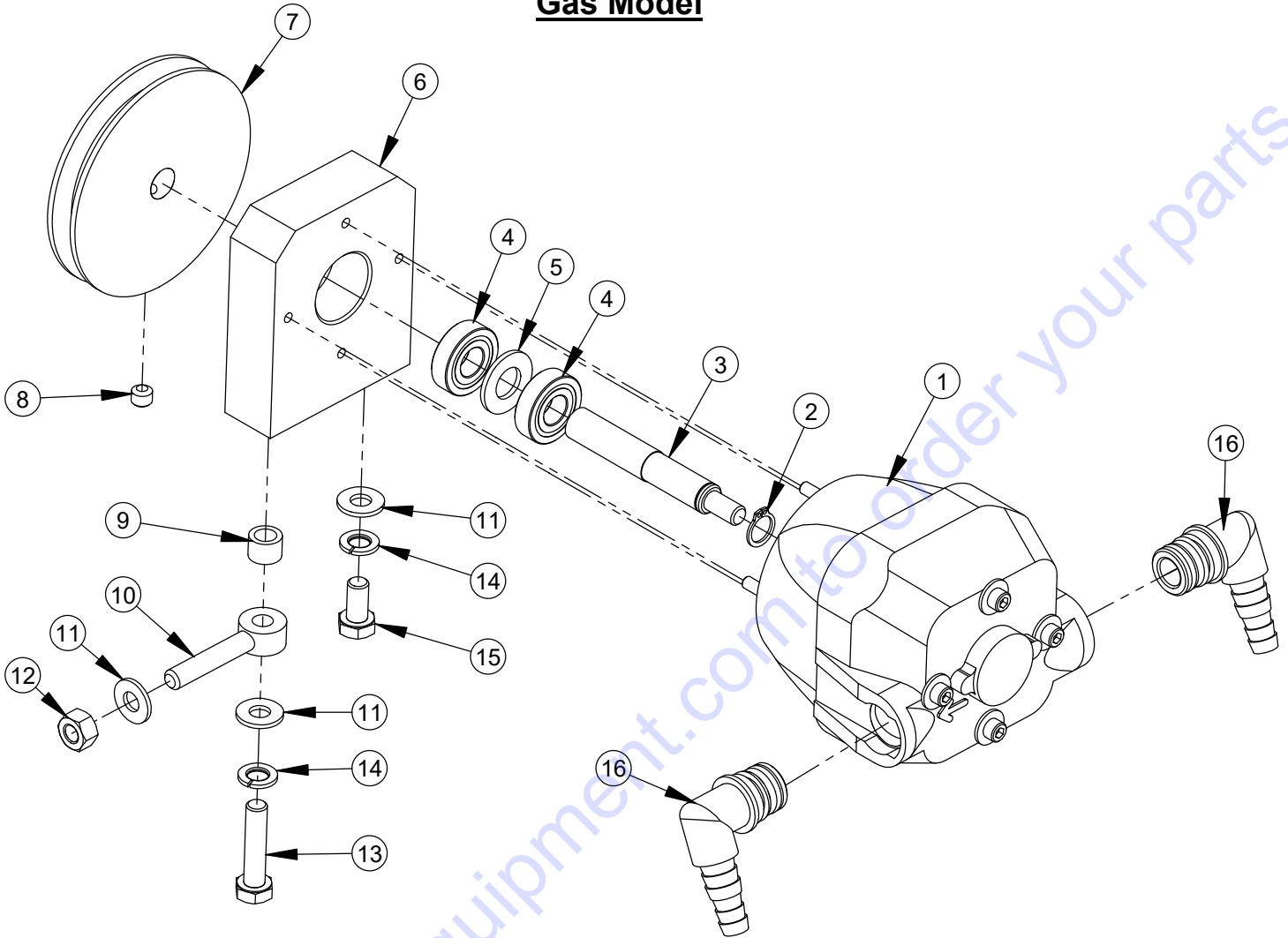

ITEM	PART NO.	QTY.	DESCRIPTION
1	2600288	1	Diaphragm Pump
2	2502247	1	Retaining Ring, Ext 12mm
3	6030428	1	Diaphragm Pump Shaft
4	2708042	2	6001 Bearing 12mm ID X 28mm OD X 8mm
5	2900239	1	Friction Washer, 1/2"
6	6030429	1	Pump Bearing Stand
7	6030431	1	1/2" (12.7mm) Bore V-belt pulley
8	2900036	1	Set Screw, Soc. Hd., 5/16-18 x 1/4"
9	6030411	1	Spacer, Outter Cart
10	2902023	1	D18 x d8 - M8 x 1.25 x 40L Eyebolt
11	2901583	3	M8 Washer (18mm OD)
12	2900303	1	Lock Nut, M8-1.25 Nylon Insert
13	2900760	1	Cap Screw, Hex Hd., M8-1.25 x 35mm
14	2900763	2	Lock Washer, M8 Split
15	2900868	1	Cap Screw, Hex Hd., M8-1.25 x 16mm
16	2702175	2	Port Fitting, 3/8" Barb 90 Degree

Water Hose Assembly - Gas

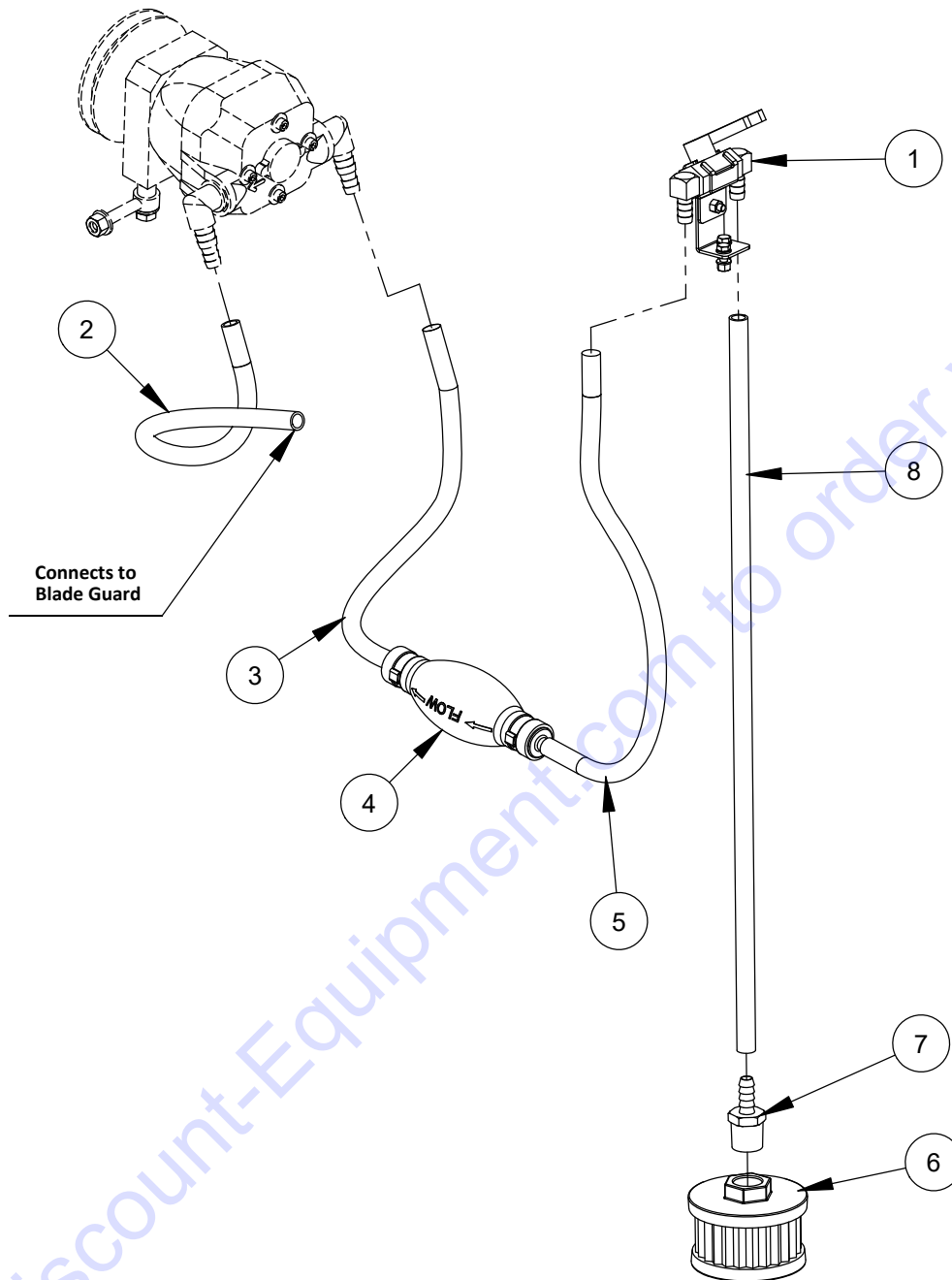

ITEM	PART NO.	QTY.	DESCRIPTION
1	6084207	1	Water Flow Valve Assembly
2	6079575	1	Hose, 1/2" OD x 3/8" ID Clear Braided - 40" L
3	6060416	1	Hose, 1/2" OD x 3/8" ID Clear Braided - 9" L
4	2500926	1	Ultra Flow Bulb, Primer
5	6075108	1	Hose, 1/2" OD x 3/8" ID Clear Braided - 10" L
6	2501373	1	Plug, 3/4" Hole
7	3200234	1	Fitting, 1/2" MPT to 3/8" Hose Barb
8	6082203	1	Hose, 1/2" OD x 3/8" ID Clear Braided - 21" L

Water Pump Assembly - Electric
#6030060

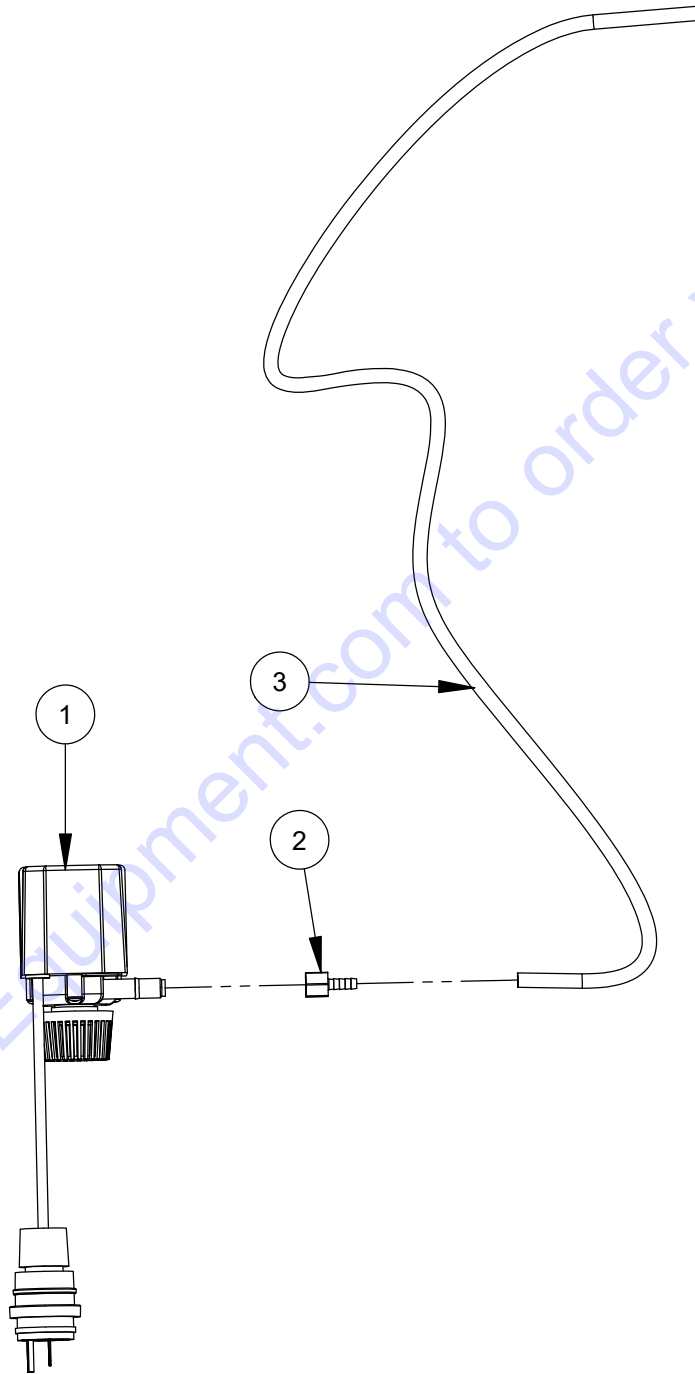

ITEM	PART NO.	QTY.	DESCRIPTION
1	2600201	1	Water Pump, Submersible 115V, 2.5 GPM (150 GPH)
2	3200231	1	Fitting, 1/4 FPT to 1/4 Hose Barb
3	6030035	1	Hose, 1/4 x 3/8 x 40" for Water Pump

Water Pump Mounting Bracket and Belt Guard Gas Engine

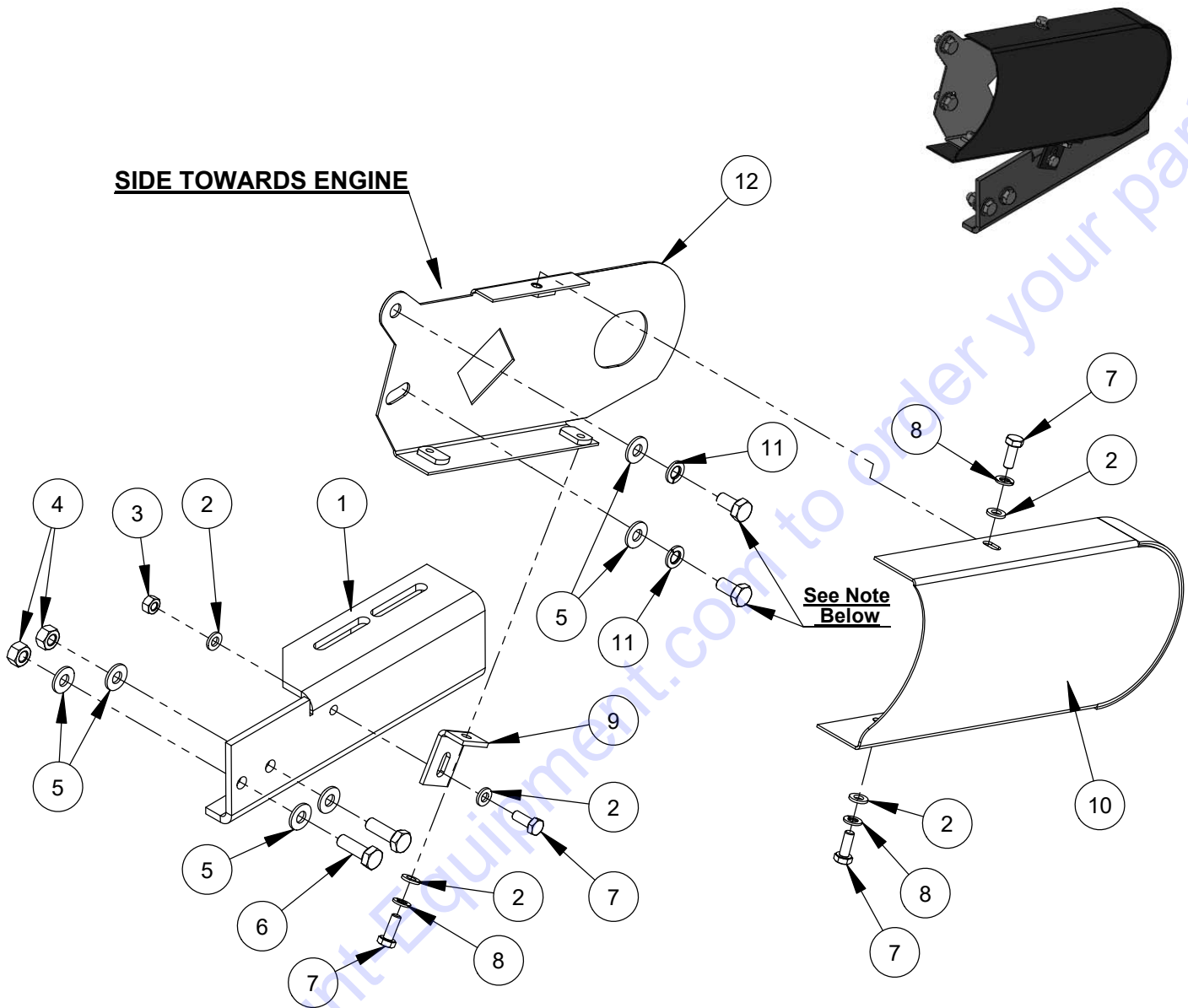

ITEM	PART NO.	QTY.	DESCRIPTION
1	6030445	1	Pump Bracket
2	2901494	5	Flat Washer, M6
3	2900302	1	Lock Nut, M6-1.0 Nylon Insert
4	2900303	2	Lock Nut, M8-1.25 Nylon Insert
5	2901583	6	M8 Washer (18mm OD)
6	2900360	2	Cap Screw, Hex Hd., M8-1.25 x 25mm
7	2900341	4	Cap Screw, Hex Hd., M6-1.0 x 16mm
8	2900765	3	Lock Washer, M6 Split
9	6051156	1	Water Pump Belt Guard Brace
10	6030446	1	Belt Guard for Pump
11	2900763	2	Lock Washer, M8 Split
12	6030399	1	Water pump belt guard bracket

Note: Refer to specific engine assembly for cap screw part number and description.

EQUIPMENT AND PARTS WARRANTY

Discount-equipment warrants all equipment sold by it against defects in workmanship or materials for a period of one (1) year from the date of shipment to Customer.

The responsibility of Discount-equipment under this Warranty is limited to replacement or repair of defective parts, of such parts as shall appear to us upon inspection at such parts, to have been defective in material or workmanship, with expense for transportation and labor borne by Customer.

In no event shall Discount-equipment be liable for consequential or incidental damages arising out of the failure of any Product to operate properly.

Integral units such as engines, electric motors, batteries, transmissions, etc., are excluded from this Warranty and are subject to the prime manufacturer's warranty.

**THIS WARRANTY IS IN LIEU OF ALL OTHER WARRANTIES,
EXPRESSED OR IMPLIED, AND ALL SUCH OTHER WARRANTIES ARE
HEREBY DISCLAIMED.**



PARTS FINDER

**Search Website
by Part Number**



**Search Manual
Library For Parts
Manual & Lookup Part
Numbers – Purchase
or Request Quote**

Search Manuals

Enter your information to help us find the right parts manual for your machine.

* Brand:

* Model:

* Serial:

* Part Number:

SEARCH

**Can't Find Part or
Manual? Request Help
by Manufacturer,
Model & Description**

Parts Order Form

Please fill in the following information to help us find the right part for your machine.

Manufacturer:	<input type="text"/>
Model:	<input type="text"/>
Description:	<input type="text"/>
Part Number:	<input type="text"/>
Quantity:	<input type="text"/>
Notes:	<input type="text"/>

Submit

Discount-Equipment.com is your online resource for quality parts & equipment.

Florida: **561-964-4949** Outside Florida TOLL FREE: **877-690-3101**

Need parts?

Click on this link: <http://www.discount-equipment.com/category/5443-parts/> and choose one of the options to help get the right parts and equipment you are looking for. Please have the machine model and serial number available in order to help us get you the correct parts. If you don't find the part on the website or on one of the online manuals, please fill out the request form and one of our experienced staff members will get back to you with a quote for the right part that your machine needs.

We sell worldwide for the brands: Genie, Terex, JLG, MultiQuip, Mikasa, Essick, Whiteman, Mayco, Toro Stone, Diamond Products, Generac Magnum, Airman, Haulotte, Barreto, Power Blanket, Nifty Lift, Atlas Copco, Chicago Pneumatic, Allmand, Miller Curber, Skyjack, Lull, Skytrak, Tsurumi, Husquvarna Target, Stow, Wacker, Sakai, Mi-T-M, Sullair, Basic, Dynapac, MBW, Weber, Bartell, Bennar Newman, Haulotte, Ditch Runner, Menegotti, Morrison, Contec, Buddy, Crown, Edco, Wyco, Bomag, Laymor, EZ Trench, Bil-Jax, F.S. Curtis, Gehl Pavers, Heli, Honda, ICS/PowerGrit, IHI, Partner, Imer, Clipper, MMD, Koshin, Rice, CH&E, General Equipment, Amida, Coleman, NAC, Gradall, Square Shooter, Kent, Stanley, Tamco, Toku, Hatz, Kohler, Robin, Wisconsin, Northrock, Oztec, Toker TK, Rol-Air, APT, Wylie, Ingersoll Rand / Doosan, Innovatech, Con X, Ammann, Mecalac, Makinex, Smith Surface Prep, Small Line, Wanco, Yanmar