

**DIAMOND
PRODUCTS**

**WALL SAW
OPERATOR'S MANUAL**

**MODEL
CC1600**

Part #: 1800745

TO PURCHASE THIS PRODUCT PLEASE CONTACT US



**Equipment Financing and
Extended Warranties Available**



**Discount-Equipment.com is your online resource for
commercial and industrial quality parts and equipment sales.**

561-964-4949

visit us on line @ www.discount-equipment.com

Select an option below to find your Equipment

Search by Manufacturer

Search by Product Type

Request a Quote

We sell worldwide for the brands: Genie, Terex, JLG, MultiQuip, Mikasa, Essick, Whiteman, Mayco, Toro Stone, Diamond Products, Generac Magnum, Airman, Haulotte, Barreto, Power Blanket, Nifty Lift, Atlas Copco, Chicago Pneumatic, Allmand, Miller Curber, Skyjack, Lull, Skytrak, Tsurumi, Husquvarna Target, Stow, Wacker, Sakai, Mi-T-M, Sullair, Basic, Dynapac, MBW, Weber, Bartell, Bennar Newman, Haulotte, Ditch Runner, Menegotti, Morrison, Contec, Buddy, Crown, Edco, Wyco, Bomag, Laymor, EZ Trench, Bil-Jax, F.S. Curtis, Gehl Pavers, Heli, Honda, ICS/PowerGrit, IHI, Partner, Imer, Clipper, MMD, Koshin, Rice, CH&E, General Equipment, Amida, Coleman, NAC, Gradall, Square Shooter, Kent, Stanley, Tamco, Toku, Hatz, Kohler, Robin, Wisconsin, Northrock, Oztec, Toker TK, Rol-Air, APT, Wylie, Ingersoll Rand / Doosan, Innovatech, Con X, Ammann, Mecalac, Makinex, Smith Surface Prep, Small Line, Wanco, Yanmar

Table of Contents

Description	Page No.
Chapter 1 – Safety	3
Personal Safety.....	3
Blade Safety.....	3
General Saw Safety.....	4
Cutting/Work Area Safety.....	4
Chapter 2 – Technical Data.....	5
Dimensions.....	5
Weight.....	5
Blade Drive.....	5
Hydraulic System.....	6
Maximum Cutting Depth.....	6
Chapter 3 – Wall Saw Set Up Instructions.....	7
Mounting the Track.....	7
Mounting the Saw.....	7
Mounting a Standard Blade.....	8
Mounting a Flush Cut Blade.....	9
Chapter 4 – Operating the Saw.....	10
Standard Cutting.....	10
Horizontal Bottom Cut.....	11
Chapter 5 – Troubleshooting.....	12
Chapter 6 – Maintenance.....	14
Daily.....	14
Weekly.....	14
Annually.....	14
Miscellaneous.....	14

List of Tables

Table 1 – Suggested Blade Speeds.....	6
Table 2 – Maximum Cutting Depth.....	6
Table 3 – Anchor Bolt Distances.....	7
Table 4 – Capacities and Recommended Specifications.....	15

Chapter 1

SAFETY

Your Diamond Products CC1600 wall saw has been designed to be as safe and efficient as possible. However, wall sawing can be hazardous if proper safety precautions are not taken and operating instructions are not followed carefully. Study this manual and remember all warnings, cautions, and tips. Keep a copy of the manual near the job site to allow the operator to review any section as needed.

SAFETY WARNINGS

PERSONAL SAFETY

- Read and understand instructions before operating saw.
- Wear proper safety clothing, including hardhat, respirator, gloves, and safety glasses. Avoid loose fitting clothing.
- Sturdy boots with non-skid soles aid in providing proper footing. Steel-toed safety boots are recommended.
- Cutting steel reinforcing bar produces sparks, avoid clothing of flammable material.
- Know how to stop the saw quickly in an emergency.
- Noise levels can be very high. Wear OSHA-approved hearing protection at all times while the saw is operating.
- Keep all parts of your body away from the blade and all other moving parts.
- Be sure that the blade guard is the correct type (flush cut or standard), is set to protect the operator, and is mounted securely on the saw.
- Do not operate the wall saw if you are under the influence of drugs or alcohol.

BLADE SAFETY

- Inspect the blade carefully before use. The blade should have no cracks, nicks, or flaws. The arbor hole should be undamaged. Use only steel centered wet cutting diamond blades manufactured for use on wall saws and recommended for your saw.
- **Do not** use dry cutting diamond blades, high-speed steel blades, carbide tipped blades, or abrasive blades.
- Only use blades marked with a maximum operating speed higher than the blade shaft speed.
- Cut only stone, concrete, reinforced concrete, and masonry materials. **Do not** cut materials such as wood, glass, or plastic.
- Inspect flanges for damage, excessive wear, and cleanliness before mounting the blade. The blade should fit snugly on a clean, undamaged shaft.
- Hydraulic power units are designed with the ability to vary the blade speed. **Never** operate the saw at a speed higher than the maximum safe allowable speed indicated on the blade. If you are unsure of the operating speed, contact Discount-equipment.
- Always keep the blade guard in place, seated firmly on the blade guard support.
- Avoid getting in direct line with the blade.

GENERAL SAW SAFETY

- Never leave the saw unattended while running.
- Do not exceed the rated pressure of hydraulic components. If you are unsure, contact Discount-equipment.
- Ensure that the track is securely mounted to the wall, with the track stop bolts in place, before starting the saw. (Track assemblies with stiffener only)
- Verify that the saw is operating properly before cutting. The track rollers must be adjusted properly and rotating freely. The motor must be connected to the power unit to rotate the blade in a clockwise direction (facing the saw from the blade). The blade must be properly mounted in the flanges. The guard must be in place and set to protect the operator. All saw functions should be checked before mounting the blade.
- Set the blade guard to give maximum protection for the operator. Inspect the blade guard frequently for damage, cracks, and wear.
- Never operate the saw without sufficient water flow to cool the blade and flush out cutting debris.
- Always disconnect the power unit before servicing the saw.
- Never try to connect or disconnect the power unit while the power unit is running and/or the hoses are under pressure.
- Before cutting, be sure that there are no electric, water, or gas lines in the area you are working. Do not saw if you are unsure of the presence of utility lines in the work area.
- The cut out section can be very heavy. (For example, a 3' x 7' door cut from a 12" thick wall will weigh over 3000 lb.) Be sure that the slab is properly secured before making the final cut.

CUTTING/WORK AREA SAFETY

- Never operate the saw in any application or job where you are not properly trained or supervised.
- Operate only in well-ventilated areas.
- Place barricades or tape to block off the work area on both sides of the wall. Keep bystanders, animals, and unnecessary equipment out the work area.
- Do not operate the saw near combustible material or fumes. Sparks occur during sawing that may cause a fire or explosion.

***FAILURE TO COMPLY WITH THE PRECEDING WARNINGS COULD
RESULT IN SERIOUS BODILY INJURY.***

Chapter 2

TECHNICAL DATA

DIMENSIONS

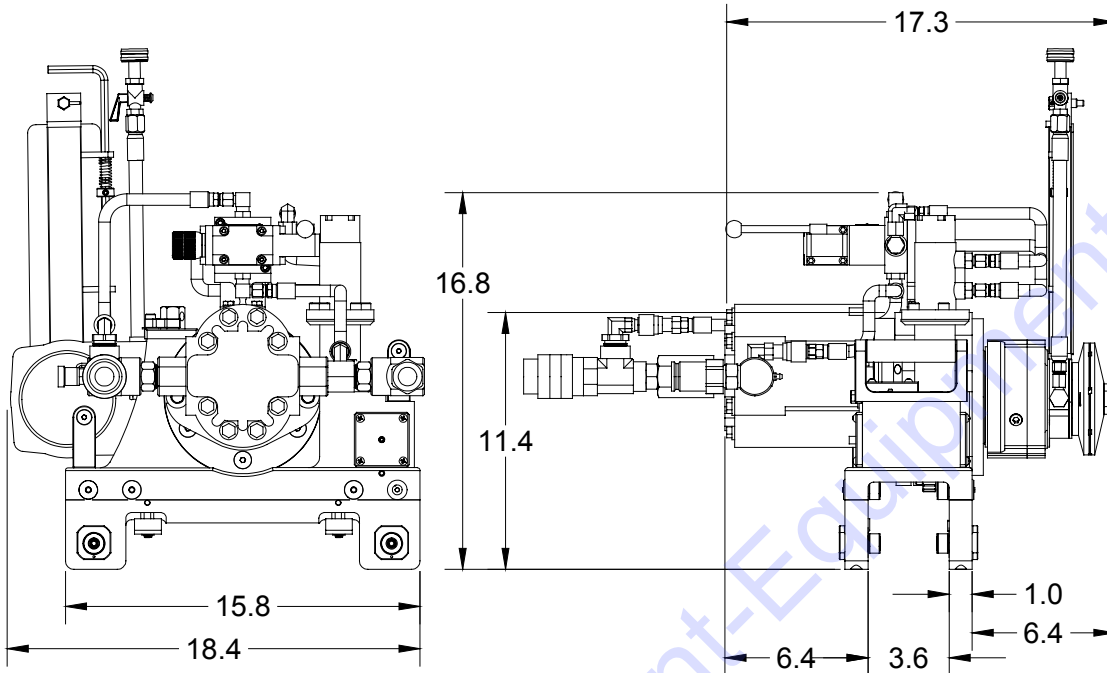

WEIGHT

Saw only (1:1 blade drive ratio)	87 lb. (37.2 kg)
Saw + Lamina motor	90 lb. (38.5 kg)
P-T Saw + Cross motor	118 lb. (49.9 kg)
Track (With stiffener), per ft.	10.9 lb. (4.9 kg)
Track (Without stiffener), per ft.	4.9 lb. (2.2 kg)

BLADE DRIVE

- Std. 3.8 hydraulic motor rated at 2500 psi (172 bar), wt 18 lb. (8.2 kg.)
- Opt. 5.2 hydraulic motor rated at 2500 psi (172 bar), wt 19 lb. (8.6 kg.)
- Travel: Hydraulic Travel motor rated at 1500 psi (103 bar)

WARNING!



Spinning the blade faster than the manufacturer's recommended speed can damage the blade and cause serious personal injury. Some manufacturers mark the maximum safe RPM on the blade.



TABLE 1
SUGGESTED BLADE SPEEDS

BLADE DIAMETER	OPTIMUM RPM	MAX SAFE RPM (D-P BLADES)	GPM 3.80 CU IN MOTOR	GPM 5.20 CU IN MOTOR
18"	2100	3400	30	
24"	1600	2500	26	
30"	1300	2000	21	
36"	1100	1700	18	24
42"	900	1400	16	20
48"	800	1200	13	18
54"	700	1100	11	16

HYDRAULIC SYSTEM

Your CC1600 wall saw is designed to operate from a separate hydraulic power unit providing up to 30 gpm at 2500 psi (up to 129 l/min at 172 bar). See blade speed table above for flow requirements with a specific blade/motor combination.

MAXIMUM CUTTING DEPTH

The CC1600 saw will cut to within 2 3/4" of the blade center. For example, a 36" blade has a radius of 18". The maximum depth of cut is 18" - 2 3/4" = 15 1/4".

TABLE 2
MAXIMUM CUTTING DEPTH

BLADE DIAMETER	MAXIMUM CUTTING DEPTH
18"	6.3"
24"	9.3"
30"	12.3"
36"	15.3"
42"	18.3"
48"	21.3"
54"	24.3"

Chapter 3

WALL SAW SET UP INSTRUCTIONS

MOUNTING THE TRACK

1. Locate the cut line on the wall.



WARNING!

Before cutting or drilling, be sure there are no electric, gas, or water lines in the area you are working. Cutting a live wire could cause electrocution, injury or death.



2. Locate a second line from the cut line in accordance with table 3 and place 1/2" anchors for the track feet on this line.

Table 3

Anchor Bolt Distances

	Longyear Style with Non-Stiffened Track	All Other Styles
Anchor Bolt Distance from Cut Line	8-1/2"	12-1/2"

3. Locate a second line 12-1/2" from the cut line, on the side you will cut from. Place 1/2" anchors for the track feet on this line. For Longyear style feet used with non-stiffened track, the anchor bolt should be 8-1/2" from the cut.
4. Thru-bolt the mounting foot on brick or concrete block walls. Use a back-up plate if needed to ensure a secure mounting. Read and follow the safety rules and mounting procedure provided by the anchor manufacturer.
5. Use leveling screws to correct for unevenness in the walls and provide stability for the mounting feet. The head of hex head leveling screws should be against the wall to prevent damage to the screw threads.
6. Mount the track on the wall with the rack on the cut side. Normally, two track feet will be sufficient on each track section however, with the non-stiffened track, a third foot may be needed when mounting the 90" or 122" length to reduce flexing when using large blades or cutting difficult materials. When using stiffened track, attach the track stop bolt into the stiffener at the top end of the track. (This acts as a safety stop in case the track slips.)

MOUNTING THE SAW

1. The saw rides the track on ten rollers, six fixed and four moveable. It is guided on the track by two fixed rollers and two adjustable slides.
2. Before mounting the saw, be sure the moveable rollers are in the "out" position.
3. Place the saw on the track with the pinion on the saw engaging the rack.
4. Push the moveable rollers to the "in" position to lock the saw onto the track. Check that the saw is secure and tight. If necessary, adjust the rollers or slides as follows:

To adjust the rollers: loosen the set screw, rotate the roller assembly with a 1-1/2" wrench until the roller is in contact with the track, then tighten the set screw. If the rollers are too loose, the saw will not cut smoothly and may jam the blade. If a roller is adjusted too tight, it will be difficult to pull out when removing the saw.

To adjust the slides: loosen the set screw, turn the adjusting shaft with a 1/2" wrench until the slide is in contact with the track, then tighten the set screw.



WARNING!

Never try to connect or disconnect the hoses while the power unit is running and/or the hoses are under pressure.



5. Connect the hydraulic lines to the blade drive motor and travel motors (if used) and the water line to the blade guard support.
6. Run the saw along the track and rotate the arm through a complete circle before mounting the blade to be sure the setup is correct.
7. Check the hydraulic and water lines while doing this to be sure they will not interfere with travel or be cut by the blade.
8. Before mounting the blade, be sure the blade shaft turns **clockwise** (looking toward the saw at the blade). Incorrect blade rotation will cause increased wear, damage the blade, and may blow out motor seals.
9. Select the correct blade, based on the depth to cut and the stage of cutting. (See Table 2) Walls over 15" thick will need more than one blade, a starting blade up to Ø36" to start the cut and one or more larger blades to complete the cut.
10. Check blade speed, either with a shaft tachometer or by checking the hydraulic fluid GPM rate and comparing it to Table 1 on page 6. **Do not exceed the rated blade speed.**
11. The CC1600 wall saw can take a blade of Ø36" or less out of the cut. To use a larger blade, you must first make a cut with a Ø36" or smaller blade.

MOUNTING A STANDARD BLADE

1. Be sure you have the correct diamond wall saw blade. Using a blade not manufactured for wall saw use could result in serious bodily injury.
2. Inspect the flanges and clean or replace if necessary. Inspect the blade for damage to the arbor hole before mounting the blade.
3. Place the blade over the arbor on the inner flange. Be sure the blade is mounted correctly. The "tails" behind the diamonds should point opposite the blade rotation. Reversing the blade will cause higher blade wear.
4. Place the outer flange over the arbor, making sure the waterways are clear.
5. Tighten the flange nut to lock the blade in place. **(NOTE: This is a left-hand nut.)**

MOUNTING A FLUSH CUT BLADE

NOTE

Always use a flush cut blade guard when flush cutting and a standard style blade guard for all other cutting.

1. Remove the standard flange from the blade shaft.
2. Mount the flush cut flange to the blade shaft.
3. Place the blade on the flush cut flange. Be sure the blade is mounted correctly. The “tails” behind the diamonds should point opposite the blade rotation. Reversing the blade will cause higher blade wear.
4. Fasten the blade to the flange with six 5/16-18 x 1” flat head socket cap screws.

To order go to Discount-Equipment.com

Chapter 4

OPERATING THE SAW

NOTE

Ensure the saw is properly set up and ready for operation in accordance with Chapter 3 of this manual.

CAUTION

To prevent seal damage, do not operate the saw without sufficient water flow. The water also assists in cooling the blade and carrying away cutting debris.

STANDARD CUTTING

1. Two operating options are available: full manual, and power travel.
 - **FULL MANUAL** – Open the inlet ball valve to start the blade rotation. Using the 15/16” socket and speed handle, turn the blade depth shaft to the desired cutting depth. Feed the saw along the cut by turning the manual travel shaft with the 15/16” socket and speed handle. The pressure needed to drive the blade will increase considerably when cutting steel, so resist forcing the saw and stalling the blade. If the blade jams, back it up to free it. If this does not work, lift the blade out of the cut until it starts turning again, then lower it back into the cut and resume cutting.
 - **POWER TRAVEL USING STANDARD HYDRAULIC ASSEMBLY** – Open the inlet ball valve to start the blade rotation. Blade depth is set manually as above. To feed the saw along the cut, set the flow control valve to “0”. Shift the directional valve in the direction you want to travel then, slowly turn the flow control valve-adjusting knob until the desired speed is attained. Continue to adjust the flow control knob as necessary to maintain desired speed.
 - **POWER TRAVEL USING OPTIONAL HYDRAULIC ASSEMBLY** – Open the inlet ball valve to start the blade rotation. Blade depth is set manually as above. To feed the saw along the cut, turn the adjusting knob counter-clockwise to the full out position. Shift the directional lever in the direction you want to travel then, slowly turn the adjusting knob clockwise until the desired speed is attained. If the saw does not move, manual assistance using the speed handle may be required to move the blade into the cut and build up enough back pressure to allow for saw movement. Continue to adjust the control knob as necessary to maintain desired speed. Feathering the directional lever toward the neutral position can attain some speed control.

WARNING!



Never stand directly in line with a spinning blade. Severe injury could result if a segment breaks off or the blade fractures.



2. All cuts must be made in steps. The first cut should be 2-3" deep. Each following cut can add up to 6" depth until the wall is cut through or the next size blade is needed.
 - If the cut runs lengthwise through a reinforcing bar, cut completely through it in one pass to prevent the blade from deviating in the cut and jamming.
 - Attempting to cut too deep in one pass will result in a poor quality cut and may cause the blade to jam.
 - When the blade diameter exceeds 36", you will have to mount the blade on the saw off the track, or place the blade in the cut then flex it slightly to fit it over the saw arbor.
3. At the end of the cut, rotate the arm deeper into the cut or take it out of the cut while the blade is still running. Do not stop the blade in the cut.
4. When the cut is complete, rotate the arm away from the cut and shut off the power unit and water supply. Remove the blade guard and blade from the saw if required. Take the saw off the track by pushing the removable rollers to the "out" position, being careful it does not fall when the last roller is released. Set the saw in a safe place while you move the track for the next cut.
5. When the final cut is complete, turn off the power unit and water supply, relieve the pressure in the hoses, and disconnect the hoses from the saw. Wash down the saw to remove all concrete slurry. Remove the blade guard and blade and store everything in a secure location.

HORIZONTAL BOTTOM CUT

1. If a horizontal bottom cut is needed, you should make it first and drive in shims to support the slab while the other cuts are made. This will prevent the slab from pinching the blade during this cut.
2. As you make additional cuts, add shims or restraining bars to keep the slab in place.
3. When making the final cut, the track should be mounted on the surrounding wall, rather than the section to be removed. If this is not possible, shims and retaining bars must be used to hold the slab in position.
4. When the final cut is complete, turn off the power unit and water supply, relieve the pressure in the hoses, and disconnect the hoses from the saw. Wash down the saw to remove all concrete slurry. Remove the blade guard and blade and store everything in a secure location.

Chapter 5

TROUBLESHOOTING

1. If your saw does not operate properly, the following table may be used as a guide in diagnosing and eliminating the problem. If you cannot fix it using this table, call our service representative.
2. Before calling, be sure you can describe the problem clearly so our representative can help you. Have this manual at hand.

TROUBLE	CAUSE	REMEDY
Saw does not move or moves erratically.	Rollers or slides out of adjustment.	Adjust rollers and slides.
	Rack is dirty.	Clean rack.
	Loose nut on Blade Depth Control Assembly	Remove assembly and tighten nut using loctite 262
	Loose nut on Manual Travel Assembly	Same as above
Blade drive pressure fluctuates.	Speed of motor is too low.	Change to a smaller motor or increase GPM.
	Power unit is defective.	Check power unit.
Blade does not rotate when valve is opened.	Blade is jammed in cut.	Remove blade from cut and try again.
	Power unit is defective.	Check power unit.
Saw motor leaks.	Motor seals are defective.	Replace motor or motor seal.
Coupling leaks.	Coupling is defective.	Replace coupling or coupling seal.

<p>Saw does not move past track joints.</p>	<p>Tracks are not aligned. Tracks are warped. Saw rollers too tight.</p>	<p>Mount tracks correctly, using jack screws to correct alignment. Readjust rollers until saw travels past joint properly.</p>
<p>No water at blade.</p>	<p>Water valve is shut. Water hose not connected properly. Low water pressure.</p>	<p>Check water supply. Check hose connections. Check water pressure (min. 15 psi)</p>
<p>Poor cutting performance.</p>	<p>Defective saw motor. Blade is glazed. Defective power unit.</p>	<p>Replace saw motor. Dress blade. Check power unit.</p>
<p>Loss of gear oil or water present in pivoting arm</p>	<p>Defective seals in support blade guard mount</p>	<p>Replace water seals</p>

To order go to Discount-Equipment.com

Chapter 6

MAINTENANCE

Proper preventative maintenance is essential to ensure a long service life, minimize downtime for repair and provide for safe, efficient operation. We recommend the following service schedule.



WARNING!

Disconnect the power unit before servicing the saw.



DAILY

- Check roller and slide alignment and for flat spots on the rollers or other conditions which might prevent free rotation. Grease rollers at least once a day.
- Check for smooth, free arm and travel motion.
- Check water flow.
- Check for hydraulic fluid leaks at the blade and travel motor connections.
- Check blade guards and flanges for damage. Replace if damaged.

WEEKLY

- Check hydraulic couplings for damage and replace if necessary.

ANNUALLY

- Major service to be carried out by Diamond Products or an authorized service representative.

MISCELLANEOUS

- Periodically check for low gear oil in the pivoting gearbox assembly and add gear oil in accordance with table 4 as required.
- Periodically check the lubrication of the main housing gears. If replacement is necessary, wipe out the old lubricant and fill the gear cavity with new lubricant in accordance with table 4 as required.

TABLE 4**CAPACITIES AND RECOMMENDED SPECIFICATIONS**

	Recommended Specifications	Capacities	Location of Use
Motor Oil	Mobile 10W30	3 oz.	Pivoting Gearbox Assembly
Grease	Mobile AW2	28 oz.	Main Housing gears (Do not lubricate the travel pinion) Roller Bearings
Thread Locking Compound	Loctite 262 High Strength (Red) Loctite 242 Medium Strength (Blue)	- -	Miscellaneous hardware (See Parts List Manual)

To order go to Discount-Equipment.com

EQUIPMENT AND PARTS WARRANTY

Discount-equipment warrants all equipment sold by it against defects in workmanship or materials for a period of one (1) year from the date of shipment to Customer.

The responsibility of Discount-equipment under this Warranty is limited to replacement or repair of defective parts, of such parts as shall appear to us upon inspection at such parts, to have been defective in material or workmanship, with expense for transportation and labor borne by Customer.

In no event shall Discount-equipment be liable for consequential or incidental damages arising out of the failure of any Product to operate properly.

Integral units such as engines, electric motors, batteries, transmissions, etc., are excluded from this Warranty and are subject to the prime manufacturer's warranty.

**THIS WARRANTY IS IN LIEU OF ALL OTHER WARRANTIES,
EXPRESSED OR IMPLIED, AND ALL SUCH OTHER WARRANTIES ARE
HEREBY DISCLAIMED.**



TO PURCHASE THIS PRODUCT PLEASE CONTACT US



**Equipment Financing and
Extended Warranties Available**



**Discount-Equipment.com is your online resource for
commercial and industrial quality parts and equipment sales.**

561-964-4949

visit us on line @ www.discount-equipment.com

Select an option below to find your Equipment

Search by Manufacturer

Search by Product Type

Request a Quote

We sell worldwide for the brands: Genie, Terex, JLG, MultiQuip, Mikasa, Essick, Whiteman, Mayco, Toro Stone, Diamond Products, Generac Magnum, Airman, Haulotte, Barreto, Power Blanket, Nifty Lift, Atlas Copco, Chicago Pneumatic, Allmand, Miller Curber, Skyjack, Lull, Skytrak, Tsurumi, Husquvarna Target, Stow, Wacker, Sakai, Mi-T-M, Sullair, Basic, Dynapac, MBW, Weber, Bartell, Bennar Newman, Haulotte, Ditch Runner, Menegotti, Morrison, Contec, Buddy, Crown, Edco, Wyco, Bomag, Laymor, EZ Trench, Bil-Jax, F.S. Curtis, Gehl Pavers, Heli, Honda, ICS/PowerGrit, IHI, Partner, Imer, Clipper, MMD, Koshin, Rice, CH&E, General Equipment, Amida, Coleman, NAC, Gradall, Square Shooter, Kent, Stanley, Tamco, Toku, Hatz, Kohler, Robin, Wisconsin, Northrock, Oztec, Toker TK, Rol-Air, APT, Wylie, Ingersoll Rand / Doosan, Innovatech, Con X, Ammann, Mecalac, Makinex, Smith Surface Prep, Small Line, Wanco, Yanmar