

# GENERAL ARRANGEMENT



ITEM	QTY	PART#	DESCRIPTION
1	1	46032-01	Saw-I Frame
2	1	26001-01	Dash Decal
7	1	46035-01	Support Pipe, Crank
8	1	46035-06	Crank
9	1	MS0400	Ball Knob
11	1	46041-01	Handlebars
11A	2	CG0100	Handle Bar Grips
12	1	46046-01	R.H. Cut Belt Guard
17	1	46037-01	Undercarriage
18	1	46036-01	Lock Lever for Crank
18A	1	SN0200	Spring for Lock Lever
19	1	46044-01	Motor Mount
23	2	46045-32	Saw Blade Pointer Arm
24	1	46037-09	Rear Axle
25	1	CT0100	Throttle Cable
26	1	40013-09	Blade Wrench
28	2	PM0200	3 Groove, 3V Section Q.D. Sheave
29	1	100040	Stop Switch Assembly
29A	1	EM0100	Stop Switch (Only)
32	2	HW0001	#8-32 X 1/2" LG. Hex Socket Button Head Cap Screw with Flatwasher & Locknut (46031-32)
33	2	40015-33	4" X 2" Front Wheel
34	1	BE0500	Thrust Bearing, Crank
35	2	46035-18	Acme Nut, Crank
36	2	HW0001	3/8" NC Tap Bolt X 3-1/2" LG. W/ Spring Lockwasher & Hex Nut (46031-36)
37	1	BS0200	S.H. Q.D. Hub W/ 1-1/4" Bore
38	1	GR0100	Rubber Grommet (46031-38)
40	5	HW0001	3/4" SAE Flat Washer (46031-40)
43	4	46037-14	Set Collar 3/4" I.D. (Front & Rear Wheel)
44	2	46031-44	8" X 2" Rear Wheel
45	2	BE0350	Pillow Block Ball Bearing, Arbor Shaft
50	8	40015-48	Replacement 3/4" Bore Bearing for Part# 46031-44 (8" Wheel) and 46031-33 (4" wheel) NOTE: (2 Bearings per Wheel) Old# 46031-50
52	4	HW0001	3/8" NC X 3/4" LG. HHCS with Locknut (46031-52)
53	4	HW0001	3/8" NC X 2" LG. HHCS w/ (2) USS Flatwasher and (1) Locknut (46031-53)
57	1	HW0001	3/8" NC X 2" LG. HHCS with Locknut (46031-57)
58	2	HW0001	3/8" USS Flatwasher Plated (46031-58)
59	3	HW0001	3/8" NC X 1" LG. HHCS W/ Locknut (46031-59)
60	2	40014-13	Bearing Support Plate
64	2	DE0900	"STURDI-SAW" Decal (46003-01)
66	1	DE2100	"NO OIL IN ENGINE" Decal
67	1	DE0300	"CAUTION/ SAFETY" Decal for Blade Guard
68	1	DE1700	ENGINE CALIFORNIA EXHAUST (Warning Decal)
69	1	BS0400	S.H. Q.D. Bushing W/ 1" Bore (Engine)



NOTE:  
 REAR LOCK BAR UNDER CHANGE UNIT SHOULD BE DRAWN FROM POINT. THE TWIN SPRINGS WILL REMAIN PLAC. BEHIND THE LOCKING UNDER THE CHANGE UNIT ENOUGH TO HOLD THE SPRING CLOSURE TO THE LOCKED OR UNLOCKED POSITION DURING SAW CUTTING OPERATIONS.

- SAW LEVEL ADJUSTMENT**  
 PLACE SAW ON FLAT SURFACE  
 IF SAW ROCKS, ADJUST AS FOLLOWS.
- 1) LOOSEN JAW NUT.
  - 2) THEN SET SCREW CLOCKWISE TO REWIND SAW ROCK ON FRONT FROM AND LEFT REAR WHEELS.
  - 3) TURN SET SCREW COUNTER CLOCKWISE TO REMOVE SAW ROCK ON LEFT FROM AND RIGHT REAR WHEELS.
  - 4) HOLDING SET SCREW, TIGHTEN JAW NUT.

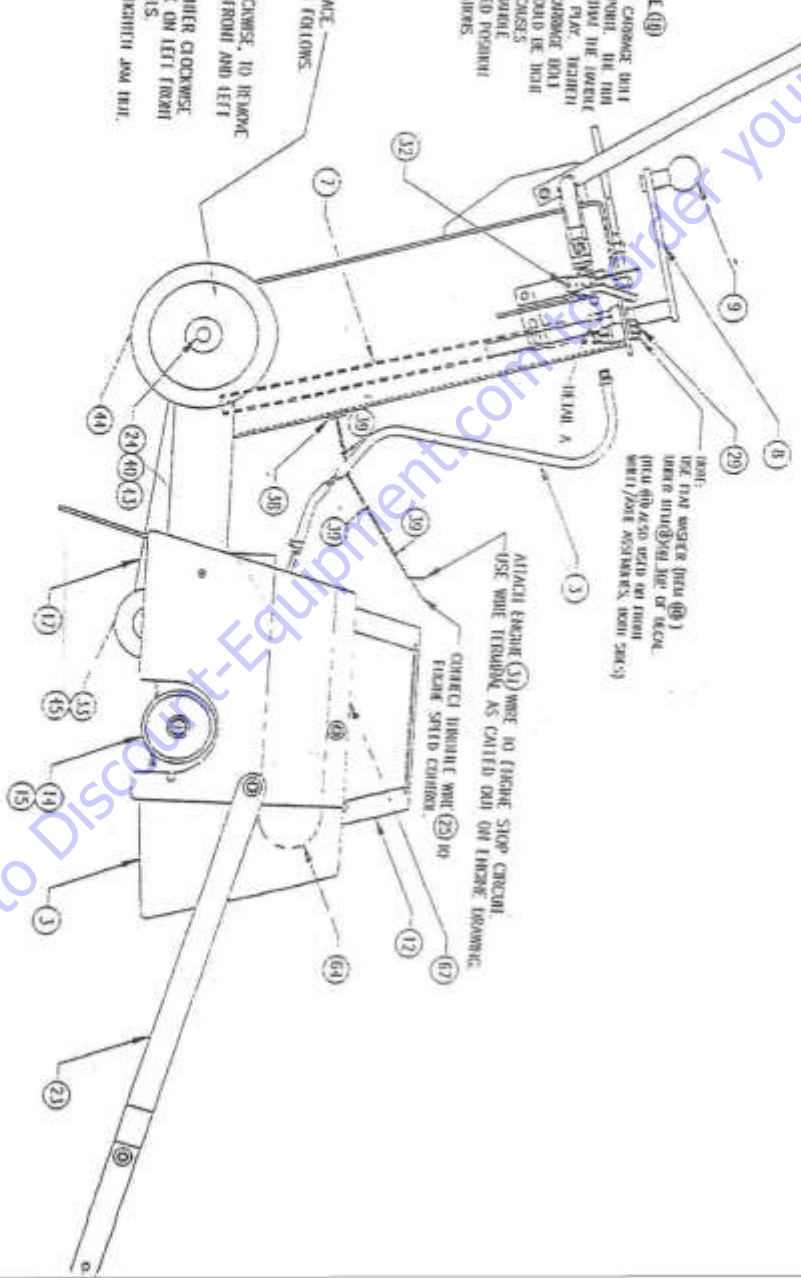

Go to Discount-Equipment.com to order your parts

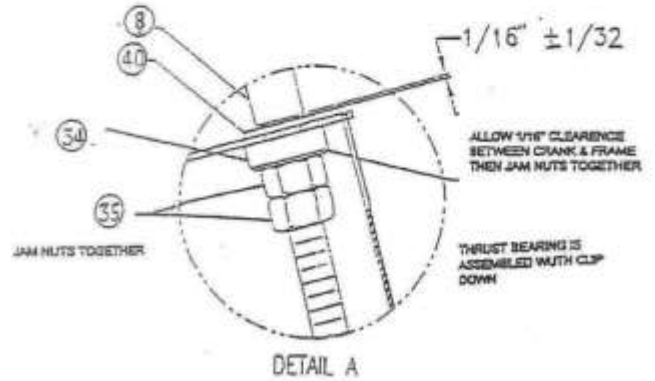
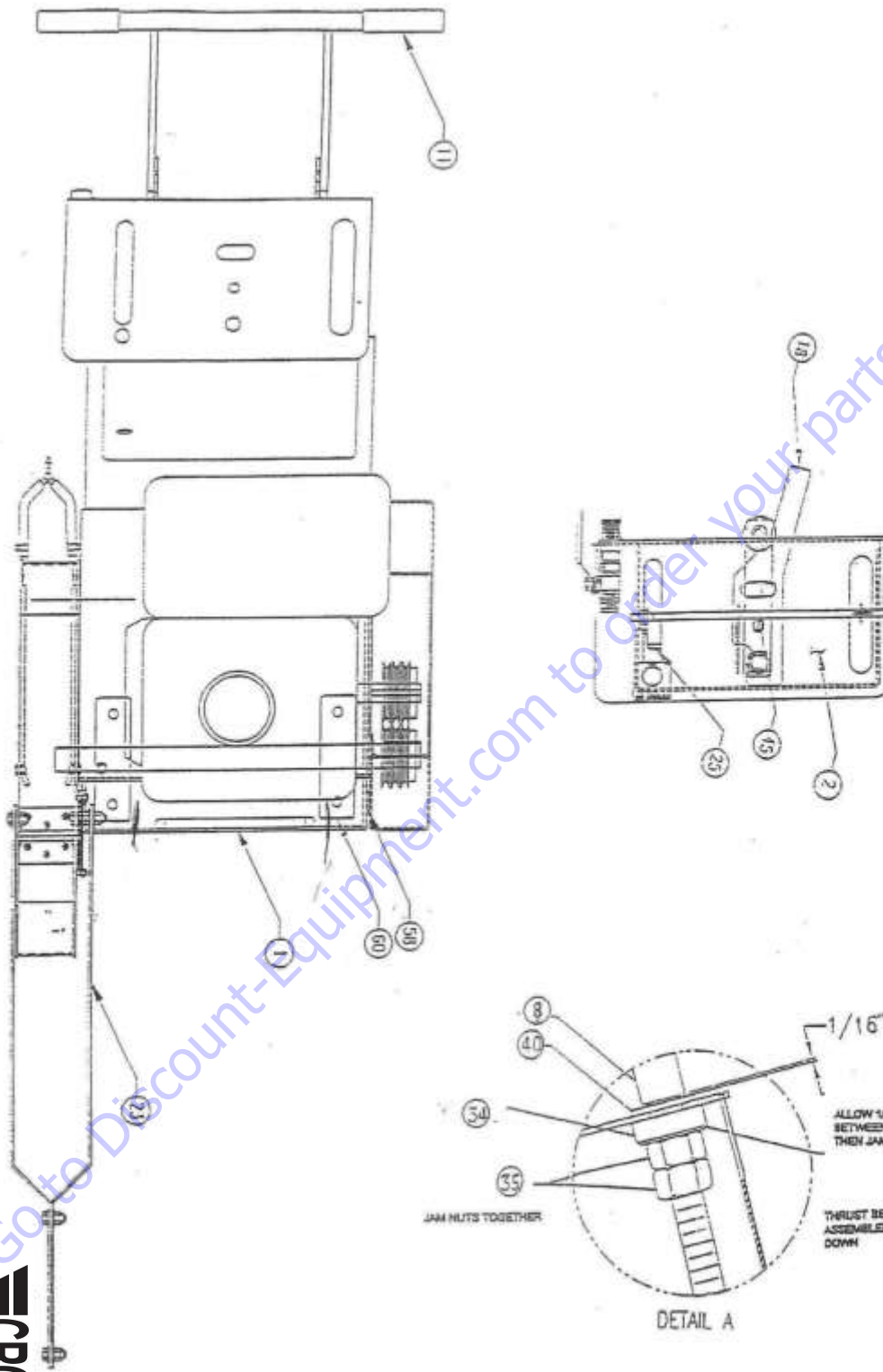

Go to [Discount-Equipment.com](http://Discount-Equipment.com) to order your parts



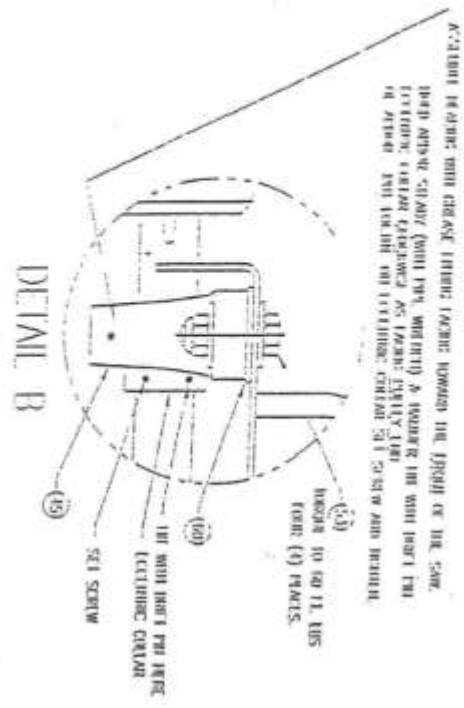
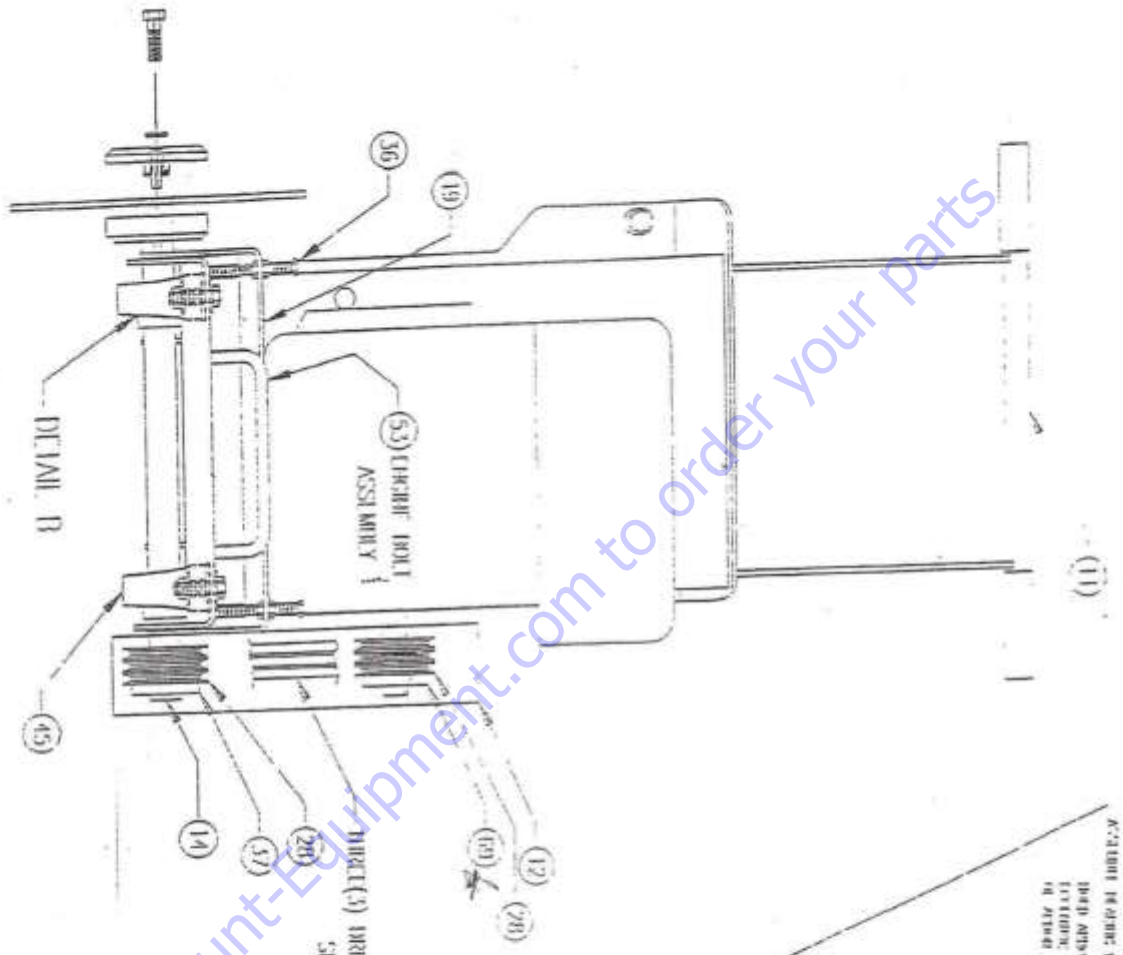



DETAIL ITEM (2)  
DUAL CUT ARBOR ASSEMBLY

ASSEMBLY NOTE: CLEAN DIRT AND OIL FROM INSIDE BLADE COLLAR (8), KEY (10), AND 1-1/16" KEYWAY IN ARBOR (3) OR (4). APPLY THREE (3) DROPS OF SAE 1-10K "1-70" THREAD LOCKING SEALANT (OR EQUIV.) TO BOTH KEYWAY AND ON STEPPED SHOULDER OF ARBOR SHAFT (5) OR (4). FULLY SEAL KEY (10) IN BOTTOM OF KEYWAY IN ARBOR SHAFT. HOLE DIRECTION OF KEY END OF KEY IN KEYWAY OF ARBOR SHAFT. TO ASSEMBLE BLADE COLLARS, FIRST POSITION INSIDE BLADE COLLAR ON STEPPED SHOULDER OF ARBOR SHAFT WITH 1/4" GAP/FACE FACING TOWARD ARBOR SHAFT. PRESS COLLAR ON AS FAR AS POSSIBLE BY HAND THEN ASSEMBLE STEPPED SHOULDER OF OUTSIDE BLADE COLLAR (5) INTO BORE OF INSIDE BLADE COLLAR, ALIGNING PIN (7) WITH HOLE IN INSIDE COLLAR. INSERT BOLT ASSEMBLY (1) INTO END OF ARBOR SHAFT AS SHOWN. TIGHTEN BOLT ASSEMBLY UNTIL INSIDE BLADE COLLAR (8) IS FULLY SEALED AGAINST STEPPED SHOULDER OF ARBOR SHAFT (3) OR (4). CAUTION: DO NOT PUT ANY THREAD LOCKING SEALANT ON BOLT ASSEMBLY (1) ON DUAL CUT SHAFT ASSEMBLY, ASSEMBLE COLLAR ON BOTH ENDS.

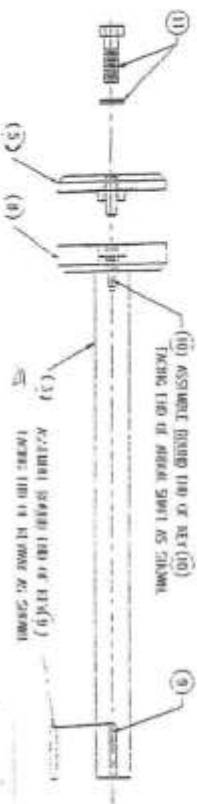

DETAIL ITEM (1)  
RIGHT HAND CUT ARBOR ASSEMBLY



## SAW-I ENGINE (13HP HONDA)

ITEM	QTY.	PART#	DESCRIPTION
1	1	EN0650	13HP Honda QXC-Engine
2	4	HW0001	3/8" NC HHCS x 1-3/4" LG. w/ SAE F W & L.N (46038-02)
3	3	BL0400	3V Cog Belt (Matched Set)
4	1	BS0400	SH QD Bushing W/ 1" Diameter Hole
5	1	HW0001	1/4" Square Key X 2" LG (46038-05)
6	1	HW0001	Quick Splice Terminal (46038-06)
7	1	HW0001	1/4" I D Loom Clamp (46038-07)
8	2	PM0200	3 Groove, 3V Section Q.D Sheave

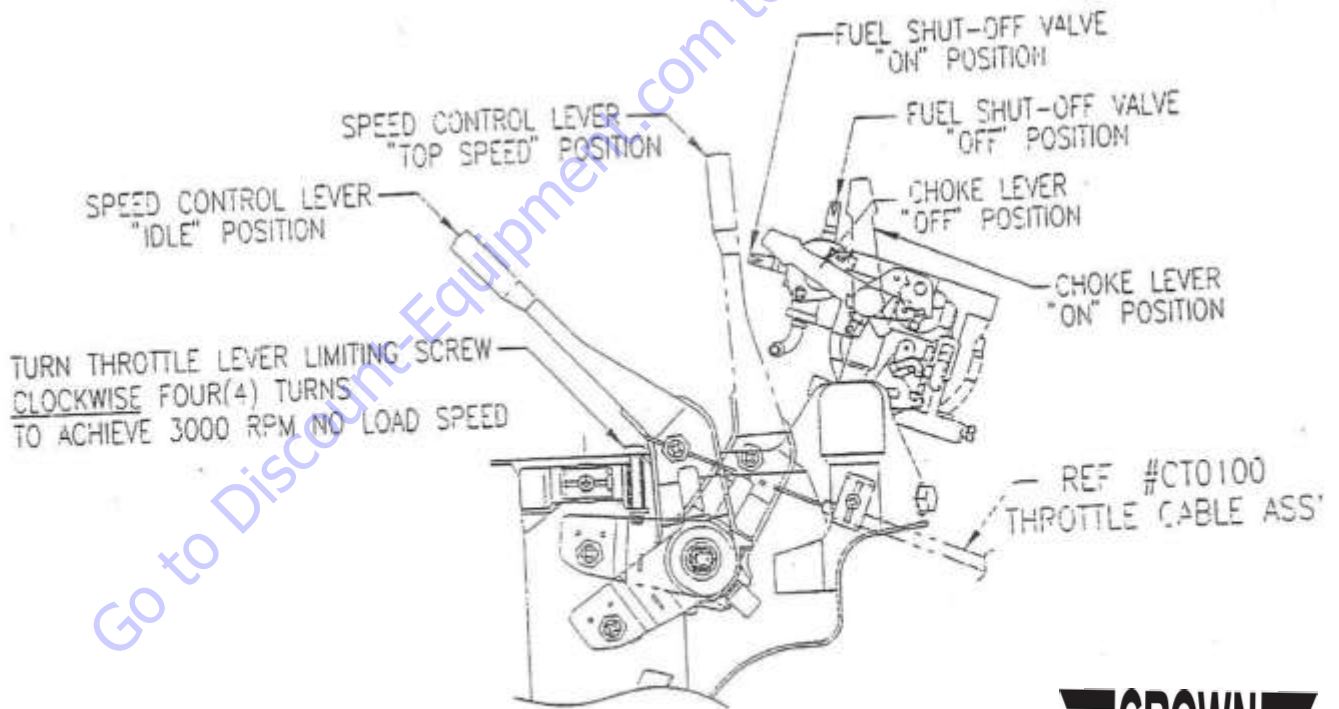

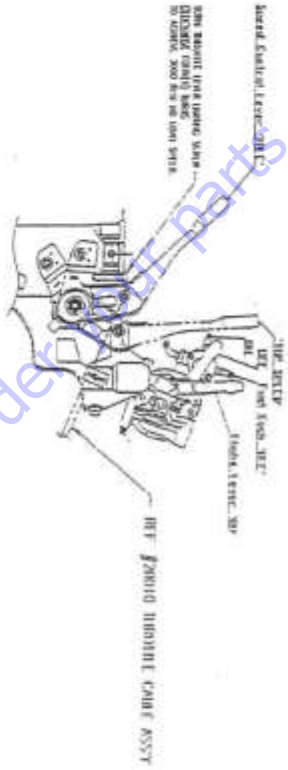
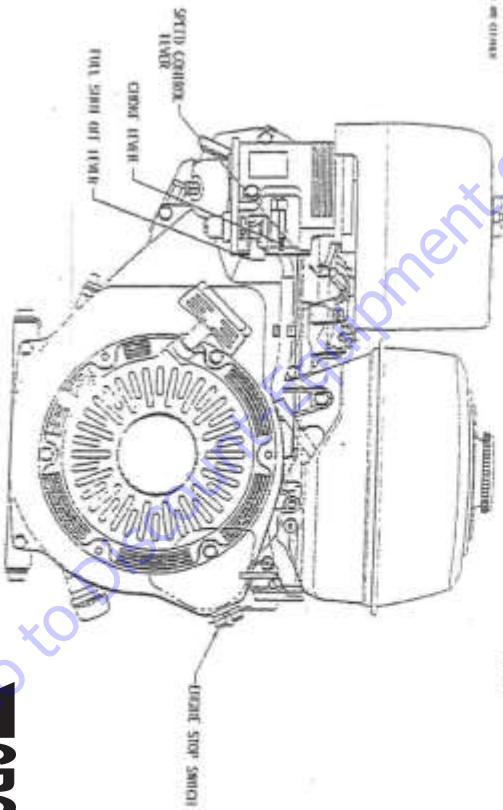
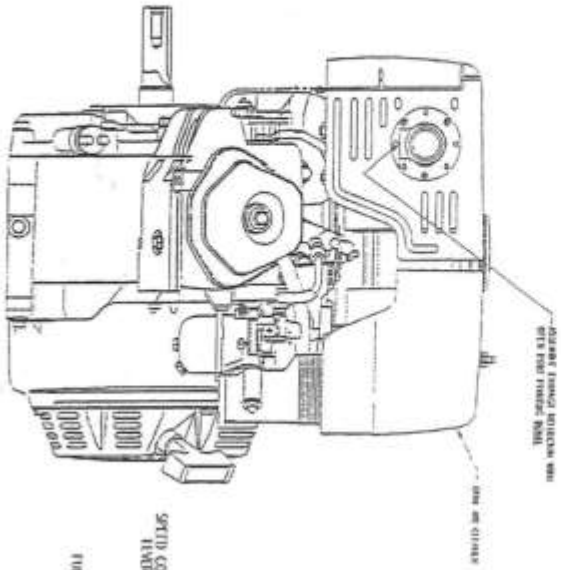



## SAW-I ENGINE (KOHLER)

ITEM	QTY.	PART#	DESCRIPTION
1	1	EN0250	15HP Kohler Recoil Start Engine (46040-01)
2	1	EN0050	Muffler/ Manifold Assembly (46040-02)
3	4	HW0001	3/8" NC HHCS x 1-1/4" LG. w/ USS F.W. & Split Lock-washer (46040-02)
4	3	BL0200	3V Cog Belt
5	1	BS0400	SH QD Bushing W/ 1" Diameter Hole
6	1	HW0001	1/4" Square Key X 2" LG. (46040-05)
7	1	HW0001	Insulated Male Blade Terminal (46040-06)
8	2	PM0200	3 Groove, Q.D. Sheave
9	1	HW0001	Pipe Nipple X 4" Long (46040-08)
10	1	HW0001	Pipe Clamp (46040-09)

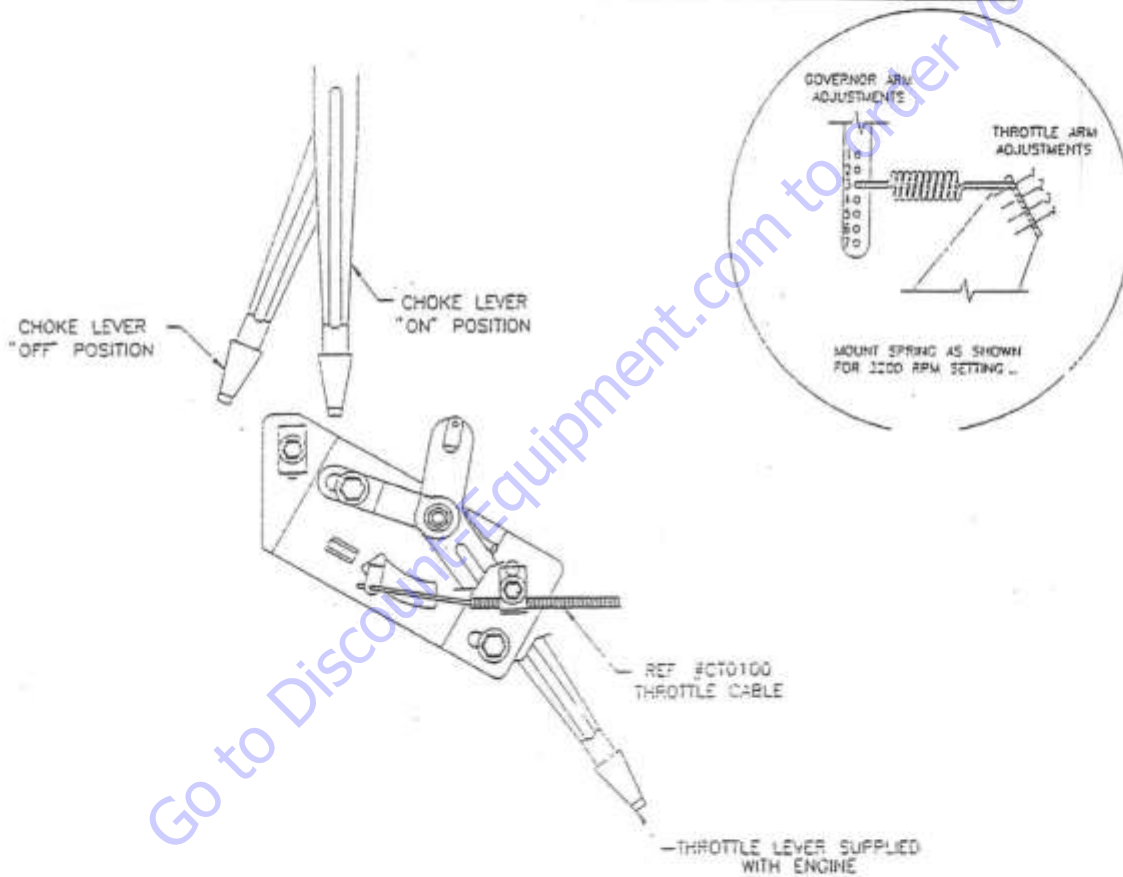

# PARTS SECTION

## Sturdi-Saw 1

SAW MODELS	ENGINE DESCRIPTION	BELT SIZE PART#	ENGINE SHEAVE (PULLEY)	Q.D. BUSHING FOR ENGINE SHEAVE
MCS-1	Saw Less Engine	Customer Supplies		
MCS-13H	13HP Honda "QXC" Model Part# EN650	3VX-315 Part# BL0400	PM0200 3-Groove Pulley	BS0400
MCS-15K	15HP Kohler Model C15T Part# EN0250	3VX-315 Part# BL0200	PM0200 3-Groove Pulley	BS0400

\*\*\* NOTE: Three (3) belts required for Sturdi-Saw 1.  
Belts are COG TYPE and should be purchased in matched sets.  
Miller part number is for one (1) belt. Always order three (3) belts.

### INSTALLATION OF ENGINE ON SAW OTHER THAN ABOVE:

Gas engines (11 to 16 HP) other than those listed above can be mounted on this saw. Consult the factory for mounting templates. Follow engine manufacturer's manual for throttle and stop switch hookup. Set governed engine speed at 3,000 RPM for wet cut diamond blades. For blades other than wet cut diamond, set engine speed at RPM required for blade being used, or set RPM at engine manufacturer's maximum allowable RPM, WHICHEVER IS LESS. NEVER EXCEED ENGINE MANUFACTURER'S MAXIMUM ALLOWABLE RPM OR ENGINE DAMAGE MAY OCCUR.

## BLADE GUARD SAW-I

ITEM	PART#	QTY. R.H. Arbor	QTY. Dual Arbor	DESCRIPTION
2	46045-02	1	2	12-18" Blade Guard Front Weldment
9	46045-09	1	2	12-18" Blade Guard Back Weldment
16	HW0001	2	4	1/4" NC HHCS X 1" LG w/Lock Nut (46045-16)
17	SH0500	1	2	Stainless Steel Hinge
18	HW0001	6	12	#10-32 Button-Head Cap Screw X 5/8" LG. W/ SAE FW & Nylock Nut Stainless(46045-18)
21	SN0400	1	2	Spring, Blade Guard(46045-21)
24	HW0001	3	5	3/8" NC HHCS X 1" LG. W/USS FW & Locknut (46045-24)
25	46045-25	2	4	Water Tubes
26	HW0001	2	4	Loom Clamp (46045-26)
27	HW0001	2	4	1/4" NC HHCS X 1/2" LG. W/ Locknut (46045-27)
28	HW0001	1	2	3/8" NC HHCS X 1" LG. W/ (4) USS FW & (1) Locknut (46045-28)
29	HW0001	1	2	3/8" NC HHCS X 1-1/4" LG. W/(2) USS FW & (1) Locknut (46045-29)
30	MS0600	1	2	Rubber Mud Flap
32	46045-32	2	4	Pointer Arm Only
33	HW0001	1	2	3/8" NC Tap Bolt X 1-1/2" LG. W/ (2) Hex Nuts, (3) USS F.W.; (1) Locknut (46045-33)
34	HW0001	3	6	3/8" NC HHCS X 1" LG. W/ (2) USS F.W. & (1) Locknut (46045-34)
35	46045-35	1	2	Nylon Rope, Pointer
37	46045-37	1	1	Vinyl Washer
38	HH0500	1	1	Garden Hose Adapter
39	MS0800	1	2	Water Valve
40	46045-40	1	2	Reducer Bushing
41	HW0001	1	2	Close Nipple (46045-41)
42	46045-42	1	2	Male Pipe to Male Barbed Hose Adapter
43	46045-43	1	1	24" Water Hose
44	FG0300	1	2	"Y" Connector (46045-44)
45	46045-45	2	4	4" Water Hose
46	46045-46	2	4	Water Hose Clamp
47	HW0001	0	1	Pipe Nipple (46045-47)
48	46045-48	0	1	36" Water Hose
49	HW0001	0	1	Pipe Tee (46045-49)
51	46045-51	1	1	Pointer Wheel
52	HW0001	1	2	7/16" HHCS X 2"lg w/Hex Nut & Hex Lock Nut

ASSEMBLY INSTRUCTIONS:

- 1) REMOVE EXISTING BOLT ASSEMBLY IN FRONT HOLE OF POINTER.
- 2) INSERT 2" LONG BOLT INTO BORE OF WHEEL.
- 3) THREAD HEX NUT ONTO BOLT AND SNUG AGAINST WHEEL.
- 4) INSERT WHEEL/BOLT ASSEMBLY INTO FRONT HOLE OF POINTER ASSEMBLY. INSTALL WHEEL/BOLT ASSEMBLY ON LEFT SIDE OF POINTER.
- 5) THREAD HEX LOCKNUT ONTO END OF BOLT.
- 6) BACK HEX NUT OFF 1/2 TURN.
- 7) HOLD BOLT WITH WRENCH AND TIGHTEN HEX LOCKNUT.
- 8) WHEEL SHOULD TURN FREELY WHEN LOCKNUT IS TIGHTENED.

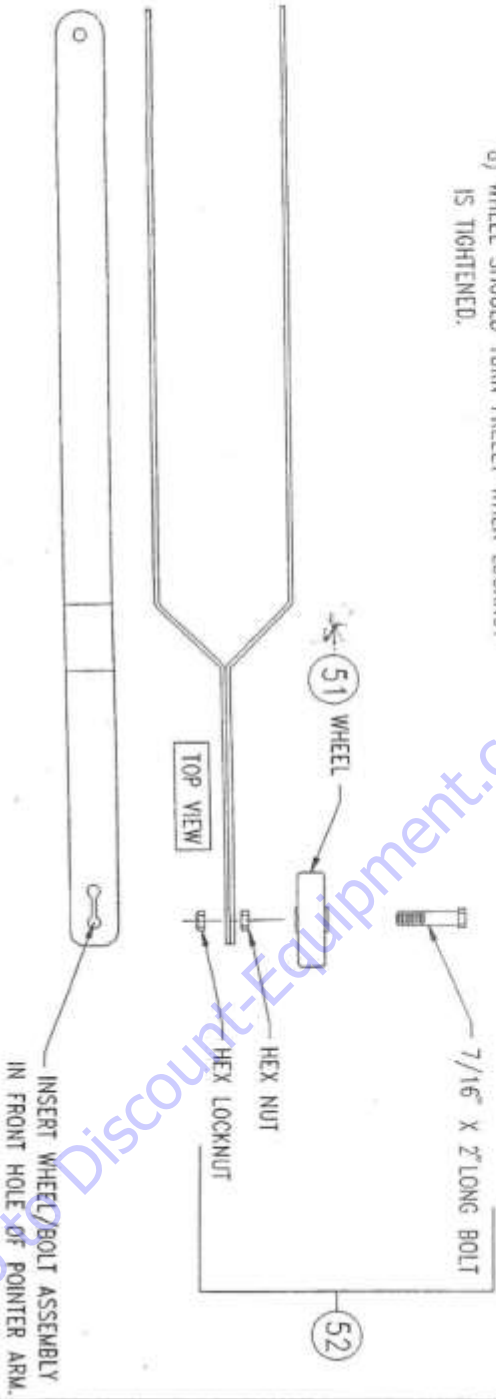

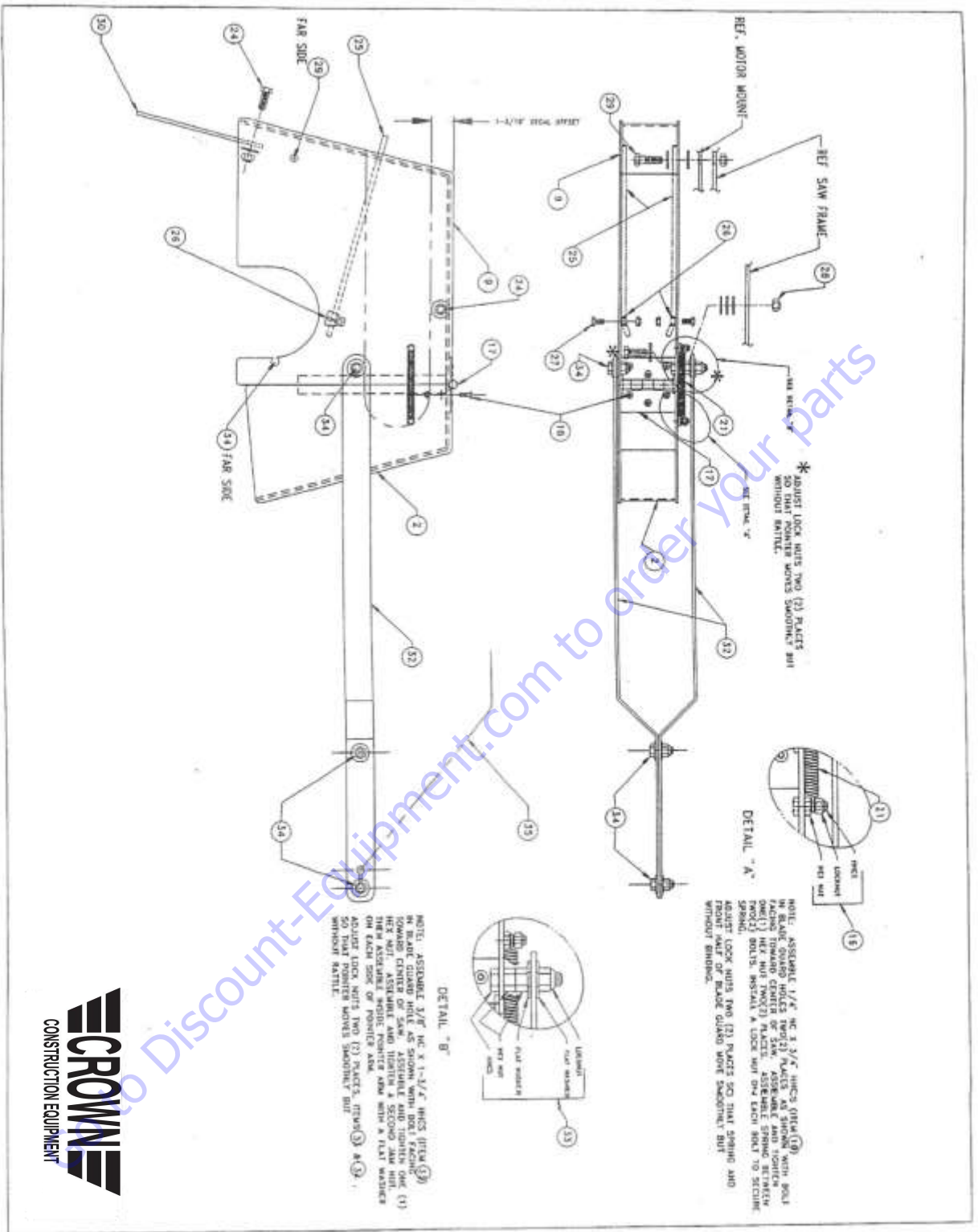

\* ADJUST LOCK NUTS TWO (2) PLACES SO THAT POINTER MOVES SMOOTHLY BUT WITHOUT RATTLE.

DETAIL "A"

NOTE: ASSEMBLE 1/4" NE 3 1/4" NUTS (ITEM 18) IN BLADE GUIDER HOLE AS SHOWN WITH BOLT (1) FACING TOWARD CENTER OF SAW. ASSEMBLE AND TIGHTEN ONE (1) HEX NUT (ITEM 21) PLACES AS SHOWN WITH BOLT (1) FACING TOWARD CENTER OF SAW. ASSEMBLE SPRING BETWEEN POINT 2) BOLTS. INSTALL A LOCK WASH (ITEM 19) TO EACH SPRING. LOCK NUTS TWO (2) PLACES SO THAT SPRING AND POINT END OF BLADE GUIDER MOVE SMOOTHLY BUT WITHOUT SHOCKS.

DETAIL "B"

NOTE: ASSEMBLE 1/4" NE 3 1/4" NUTS (ITEM 18) IN BLADE GUIDER HOLE AS SHOWN WITH BOLT (1) FACING TOWARD CENTER OF SAW. ASSEMBLE AND TIGHTEN ONE (1) HEX NUT (ITEM 21) PLACES AS SHOWN WITH BOLT (1) FACING TOWARD CENTER OF SAW. ASSEMBLE SPRING BETWEEN POINT 2) BOLTS. INSTALL A LOCK WASH (ITEM 19) TO EACH SPRING. LOCK NUTS TWO (2) PLACES SO THAT SPRING AND POINT END OF BLADE GUIDER MOVE SMOOTHLY BUT WITHOUT RATTLE.



Discount-Equipment.com to order your parts



107 SAW FRAME W/WELDED COUPLING.

NOTE SUBASSEMBLE ITEM (38) FOR SHIPPING  
SHIP ALL OTHER WATER SYSTEM ITEMS  
LOOSE IN A BOX FOR CUSTOMER  
ASSEMBLY

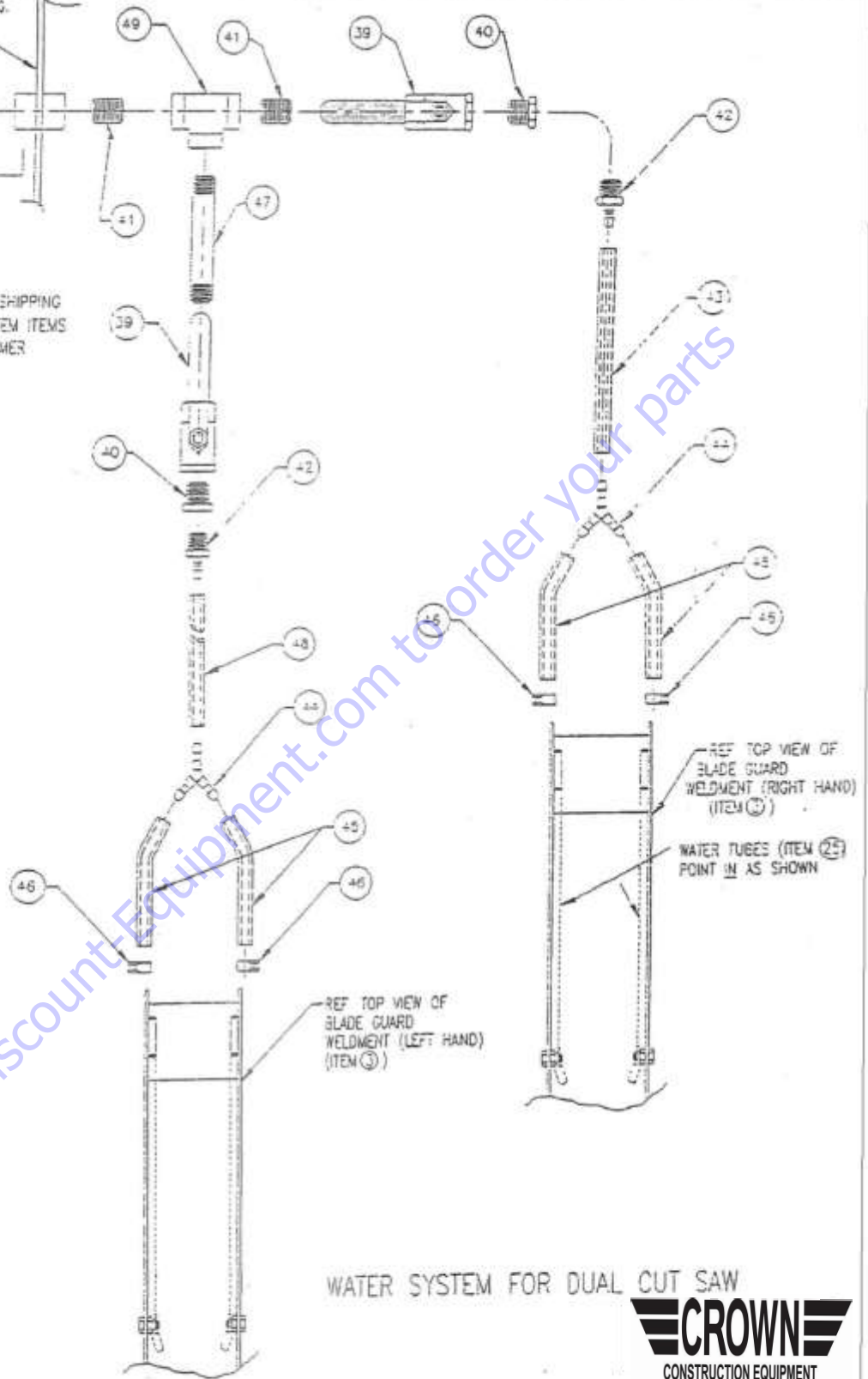

WATER SYSTEM FOR DUAL CUT SAW



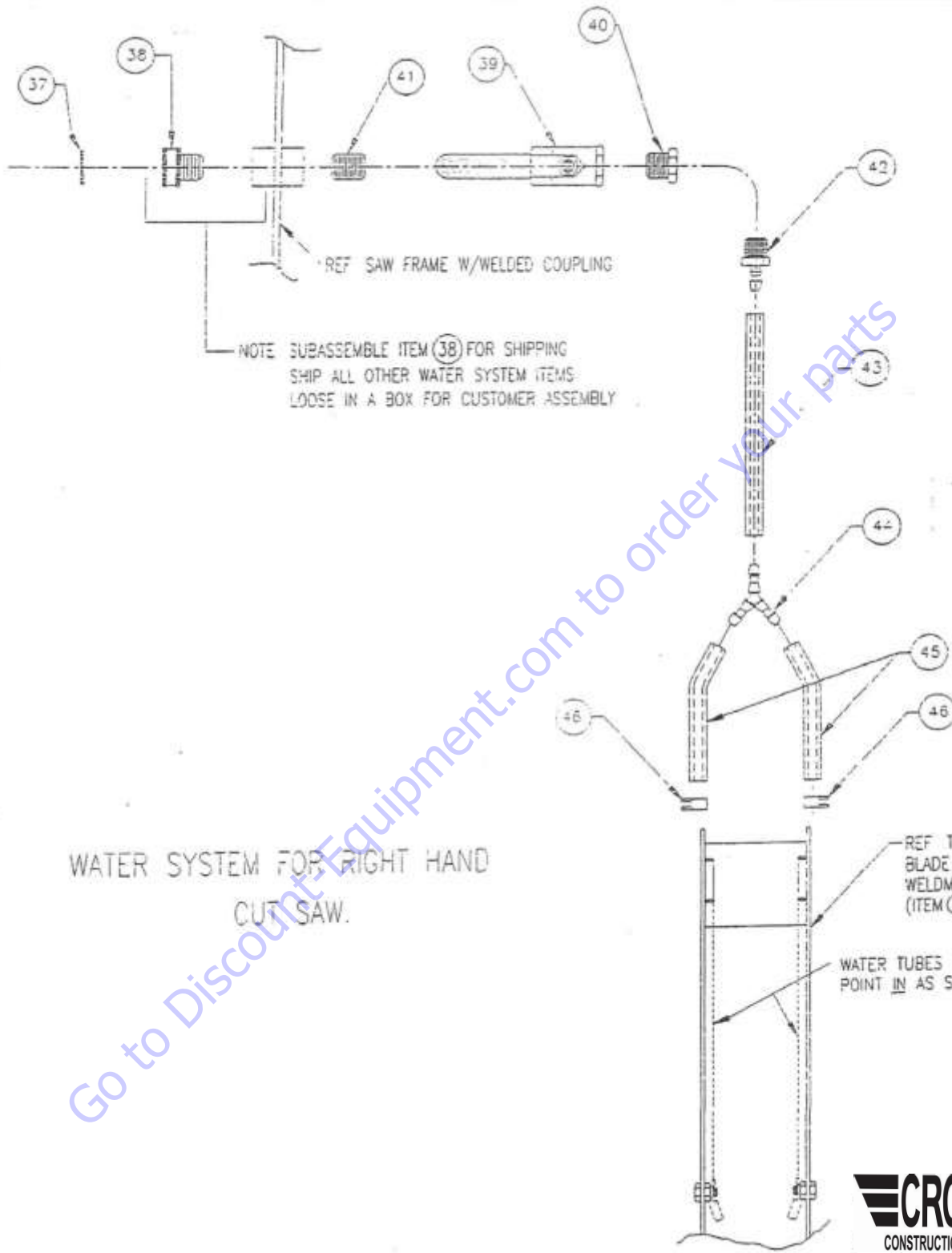

Go to [DiscountEquipment.com](http://DiscountEquipment.com) to order your parts



**SAW-I**  
**DEPTH INDICATOR**  
(Optional Equipment)

ITEM	QTY	PART#	DESCRIPTION
1	1	46006-1	Depth Indicator Assy (Complete)
2	1	46006-2	Threaded Shaft
7	1	46006-7	Depth Indicator Bar
8	2	46006-8	3/8" NC Hex Nylock Locknut, Plated
9	2	46006-9	3/8" NC Hex Nut, Plated
10	1	46006-10	1/2" Belleville Spring Washer
11	1	46006-11	3/8" HHCS X 3/4" LG
12	2	46006-12	3/8" SAE Flatwasher
13	1	46006-13	Depth Indicator Scale Decal

Go to [Discount-Equipment.com](http://Discount-Equipment.com) to order your parts

## GENERAL ARRANGEMENT

ITEM	QTY	PART#	DESCRIPTION
1	1	46032-01	Saw-I Frame
2	1	26001-01	Dash Decal
7	1	46035-01	Support Pipe, Crank
8	1	46035-06	Crank
9	1	MS0400	Ball Knob
11	1	46041-01	Handlebars
11A	2	CG0100	Handle Bar Grips
12	1	46046-01	R.H. Cut Belt Guard
17	1	46037-01	Undercarriage
18	1	46036-01	Lock Lever for Crank
18A	1	SN0200	Spring for Lock Lever
19	1	46044-01	Motor Mount
23	2	46045-32	Saw Blade Pointer Arm
24	1	46037-09	Rear Axle
25	1	CT0100	Throttle Cable
26	1	40013-09	Blade Wrench
28	2	PM0200	3 Groove, 3V Section Q.D. Sheave
29	1	100040	Stop Switch Assembly
29A	1	EM0100	Stop Switch (Only)
32	2	HW0001	#8-32 X 1/2" LG. Hex Socket Button Head Cap Screw with Flatwasher & Locknut (46031-32)
33	2	40015-33	4" X 2" Front Wheel
34	1	BE0500	Thrust Bearing, Crank
35	2	46035-18	Acme Nut, Crank
36	2	HW0001	3/8" NC Tap Bolt X 3-1/2" LG. W/ Spring Lockwasher & Hex Nut (46031-36)
37	1	BS0200	S.H. Q.D. Hub W/ 1-1/4" Bore
38	1	GR0100	Rubber Grommet (46031-38)
40	5	HW0001	3/4" SAE Flat Washer (46031-40)
43	4	46037-14	Set Collar 3/4" I.D. (Front & Rear Wheel)
44	2	46031-44	8" X 2" Rear Wheel
45	2	BE0350	Pillow Block Ball Bearing, Arbor Shaft
50	8	40015-48	Replacement 3/4" Bore Bearing for Part# 46031-44 (8" Wheel) and 46031-33 (4" wheel) NOTE: (2 Bearings per Wheel) Old# 46031-50
52	4	HW0001	3/8" NC X 3/4" LG. HHCS with Locknut (46031-52)
53	4	HW0001	3/8" NC X 2" LG. HHCS w/ (2) USS Flatwasher and (1) Locknut (46031-53)
57	1	HW0001	3/8" NC X 2" LG. HHCS with Locknut (46031-57)
58	2	HW0001	3/8" USS Flatwasher Plated (46031-58)
59	3	HW0001	3/8" NC X 1" LG. HHCS W/ Locknut (46031-59)
60	2	40014-13	Bearing Support Plate
64	2	DE0900	"STURDI-SAW" Decal (46003-01)
66	1	DE2100	"NO OIL IN ENGINE" Decal
67	1	DE0300	"CAUTION/ SAFETY" Decal for Blade Guard
68	1	DE1700	ENGINE CALIFORNIA EXHAUST (Warning Decal)
69	1	BS0400	S.H. Q.D. Bushing W/ 1" Bore (Engine)



## GENERAL ARRANGEMENT

ITEM	QTY	PART#	DESCRIPTION
1	1	46032-01	Saw-I Frame
2	1	26001-01	Dash Decal
7	1	46035-01	Support Pipe, Crank
8	1	46035-06	Crank
9	1	MS0400	Ball Knob
11	1	46041-01	Handlebars
11A	2	CG0100	Handle Bar Grips
12	1	46046-01	R.H. Cut Belt Guard
17	1	46037-01	Undercarriage
18	1	46036-01	Lock Lever for Crank
18A	1	SN0200	Spring for Lock Lever
19	1	46044-01	Motor Mount
23	2	46045-32	Saw Blade Pointer Arm
24	1	46037-09	Rear Axle
25	1	CT0100	Throttle Cable
26	1	40013-09	Blade Wrench
28	2	PM0200	3 Groove, 3V Section Q.D. Sheave
29	1	100040	Stop Switch Assembly
29A	1	EM0100	Stop Switch (Only)
32	2	HW0001	#8-32 X 1/2" LG. Hex Socket Button Head Cap Screw with Flatwasher & Locknut (46031-32)
33	2	40015-33	4" X 2" Front Wheel
34	1	BE0500	Thrust Bearing, Crank
35	2	46035-18	Acme Nut, Crank
36	2	HW0001	3/8" NC Tap Bolt X 3-1/2" LG. W/ Spring Lockwasher & Hex Nut (46031-36)
37	1	BS0200	S.H. Q.D. Hub W/ 1-1/4" Bore
38	1	GR0100	Rubber Grommet (46031-38)
40	5	HW0001	3/4" SAE Flat Washer (46031-40)
43	4	46037-14	Set Collar 3/4" I.D. (Front & Rear Wheel)
44	2	46031-44	8" X 2" Rear Wheel
45	2	BE0350	Pillow Block Ball Bearing, Arbor Shaft
50	8	40015-48	Replacement 3/4" Bore Bearing for Part# 46031-44 (8" Wheel) and 46031-33 (4" wheel) NOTE: (2 Bearings per Wheel) Old# 46031-50
52	4	HW0001	3/8" NC X 3/4" LG. HHCS with Locknut (46031-52)
53	4	HW0001	3/8" NC X 2" LG. HHCS w/ (2) USS Flatwasher and (1) Locknut (46031-53)
57	1	HW0001	3/8" NC X 2" LG. HHCS with Locknut (46031-57)
58	2	HW0001	3/8" USS Flatwasher Plated (46031-58)
59	3	HW0001	3/8" NC X 1" LG. HHCS W/ Locknut (46031-59)
60	2	40014-13	Bearing Support Plate
64	2	DE0900	"STURDI-SAW" Decal (46003-01)
66	1	DE2100	"NO OIL IN ENGINE" Decal
67	1	DE0300	"CAUTION/ SAFETY" Decal for Blade Guard
68	1	DE1700	ENGINE CALIFORNIA EXHAUST (Warning Decal)
69	1	BS0400	S.H. Q.D. Bushing W/ 1" Bore (Engine)





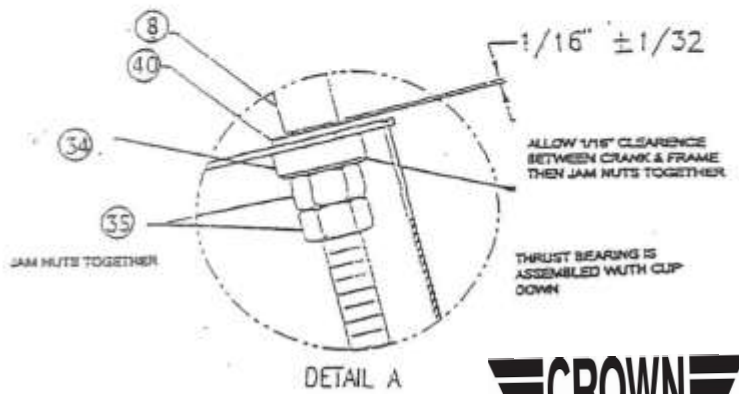
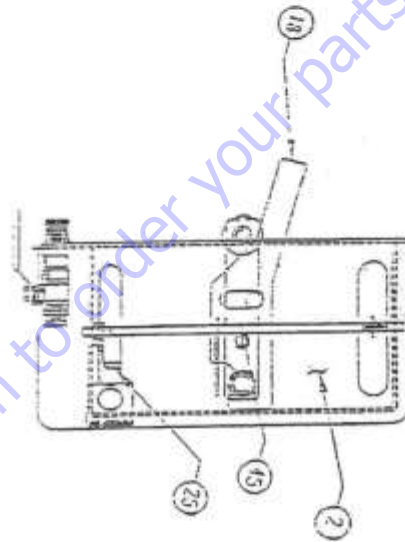
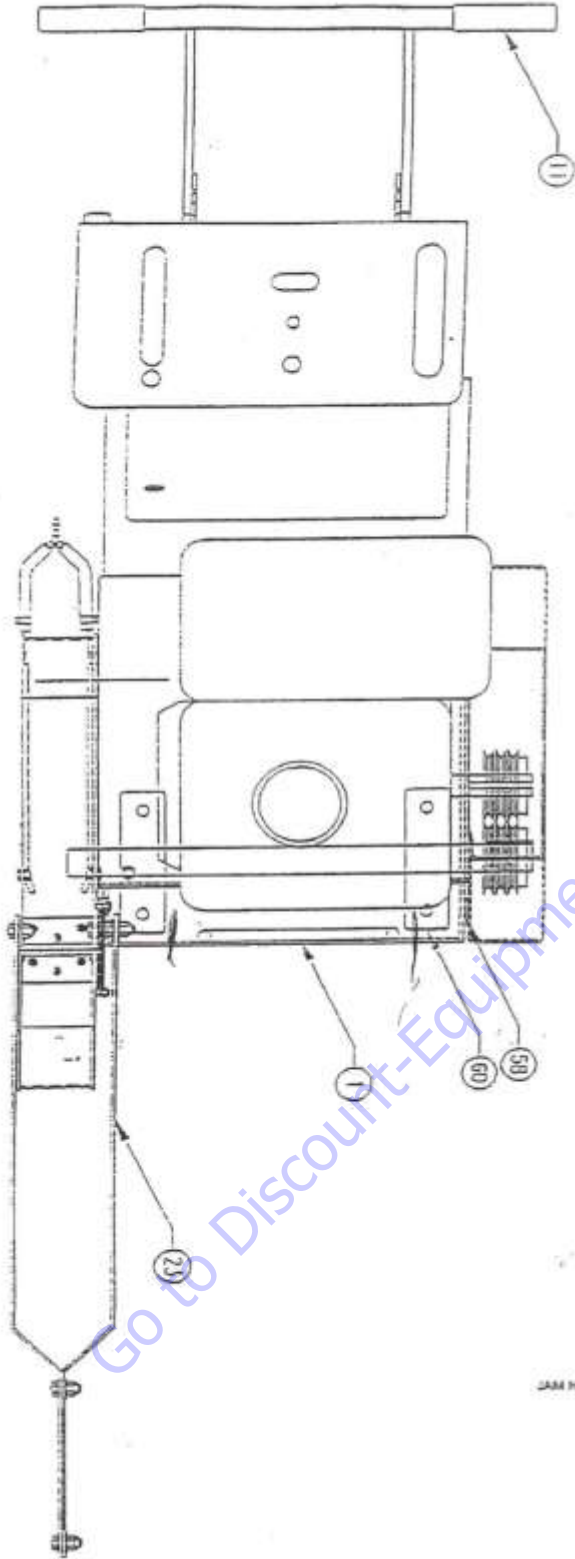

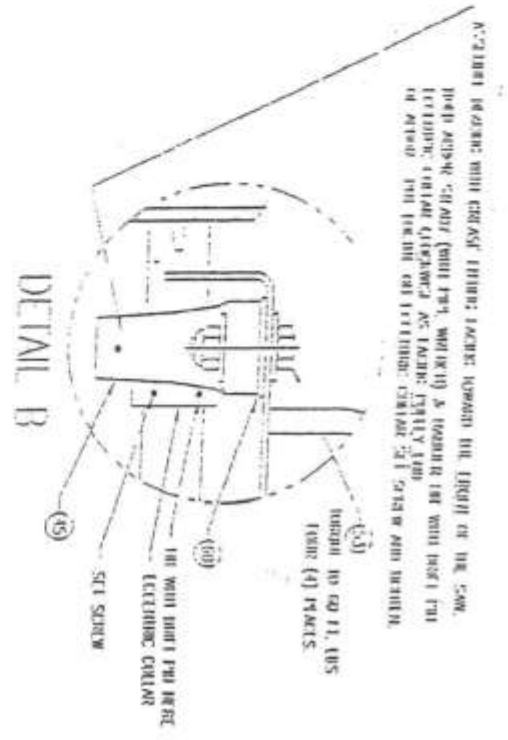
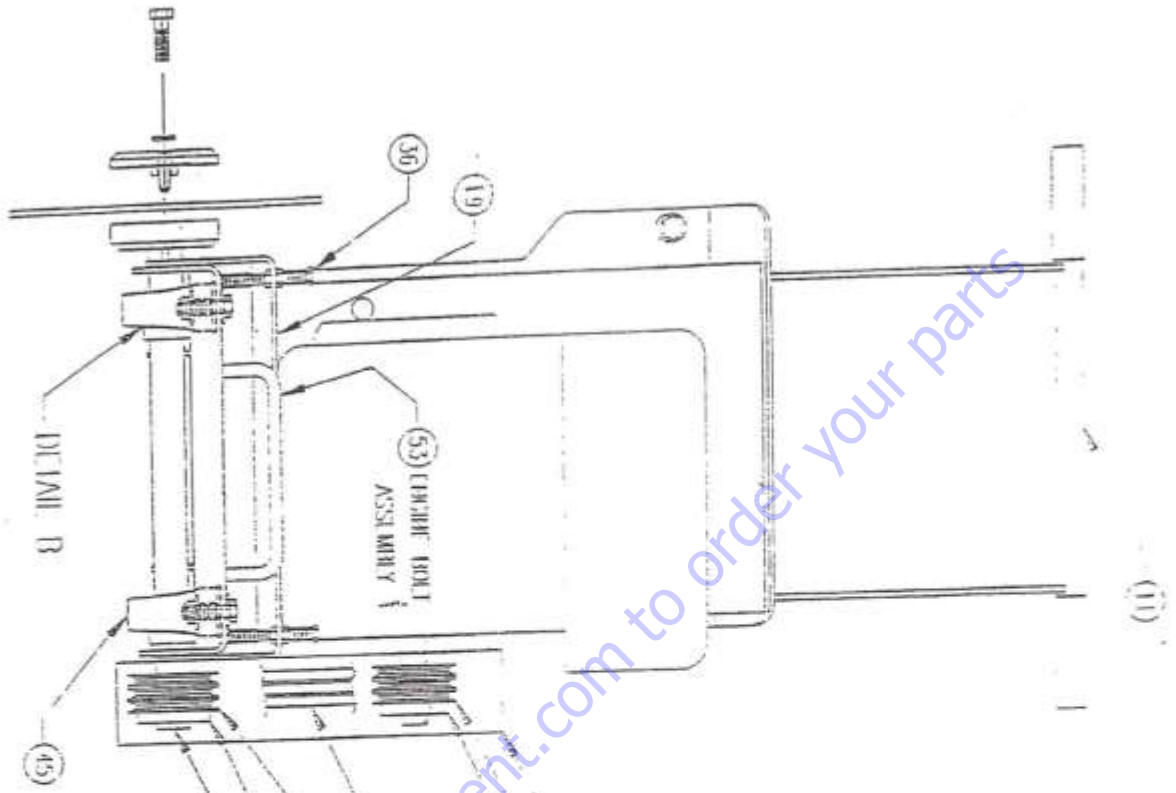

NOTE: BEARING WITH CRASH FITTING LOCATED UPWARD END OF THE SAW. THIS BEARING SHOULD BE REMOVED AS FACTOR OF SAFETY FOR THE OPERATOR. THE BEARING IS LOCATED INSIDE THE SAW AND BEARING.

IRREGULAR DRIVE BELLS, MATCHED SET  
SEE ENGINE PARTS LIST



Go to Discount-Equipment.com to order your parts

## ARBOR SHAFT ASSY.

ITEM	PART#	QTY. R.H. ARBOR	QTY. DUAL ARBOR	DESCRIPTION
1	46033-01	1	0	Right Hand Q R Arbor Shaft Assy
3	46033-3	1	0	Right Hand Arbor Shaft, Q R
4	46033-4	0	1	Dual Cut Arbor Shaft, Q R
5	46033-5	1	2	Outside Blade Collar W/ Pin
7	46033-7	1	2	Alloy Dowell Pin
8	46033-8	1	2	Inside Blade Collar
9	HW0001	1	1	1/4" X 2" Sqare Key (46033-09)
10	HW0001	1	2	1/4" X 1" Sqare Key (46033-10)
11	HW0001	1	2	1/2" NC HHCS X 1-3/4" LG W/ Spring-Lock Washer (46033-11)
13	40013-09	1	1	Blade Wrench, Q R

Go to Discount-Equipment.com to find your parts



DETAIL ITEM (2)  
DUAL CUT ARBOR ASSEMBLY

ASSEMBLY NOTE. CLEAN DIRT AND OIL FROM INSIDE BLADE COLLAR (8), KEY (10), AND 1-1/16" LG. KEYWAY IN ARBOR (3) OR (4). APPLY THREE(3) DROPS OF SAE-1-TOR "1" 30 THREAD LOCKING SEALANT (OR EQUIV.) TO BOTH KEYWAY AND ON STEPPED SHOULDER OF ARBOR SHIRT (3) OR (4). FULLY SEAL KEY (10) IN BOTH END OF KEYWAY IN ARBOR SHIRT. HOLE DIRECTION OF ROUNDED END OF KEY IN KEYWAY OF ARBOR SHIRT.

TO ASSEMBLE BLADE COLLARS, FIRST POSITION INSIDE BLADE COLLAR ON STEPPED SHOULDER OF ARBOR SHIRT WITH 1/4" DIAMETER FACING TOWARD ARBOR SHAFT. PRESS COLLAR ON AS FAR AS POSSIBLE BY HAND THEN ASSEMBLE STEPPED SHOULDER OF OUTSIDE BLADE COLLAR (5) INTO BORE OF INSIDE BLADE COLLAR, ALIGNING PIN (7) WITH HOLE IN INSIDE COLLAR. INSERT BOLT ASSEMBLY (11) INTO END OF ARBOR SHIRT AS SHOWN. TIGHTEN BOLT ASSEMBLY UNTIL INSIDE BLADE COLLAR (8) IS FULLY SEATED AGAINST STEPPED SHOULDER OF ARBOR SHIRT (3) OR (4). CAUTION: DO NOT PUT ANY THREAD LOCKING SEALANT ON BOLT ASSEMBLY (11) ON DUAL CUT SHIRT ASSEMBLY, ASSEMBLE COLLARS ON BOTH ENDS.

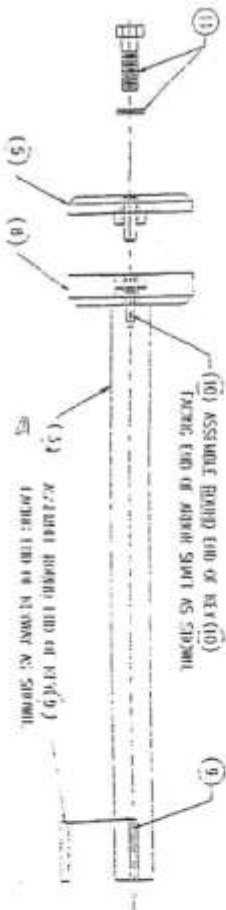

DETAIL ITEM (1)



# PARTS FINDER

**Search Website  
by Part Number**



**Search Manual  
Library For Parts  
Manual & Lookup Part  
Numbers – Purchase  
or Request Quote**

**Search Manuals**

Enter your information to search for manuals and parts.

\* Brand:

\* Model:

\* Serial:

\* Part Number:

SEARCH

**Can't Find Part or  
Manual? Request Help  
by Manufacturer,  
Model & Description**

**Parts Order Form**

Please fill in the following information:

Manufacturer:

Model:

Description:

Quantity:

Part Number:

Part Name:

Part Description:

Part Location:

Part Condition:

Part Status:

Part Material:

Part Color:

Part Weight:

Part Dimensions:

Part Price:

Part Notes:

Submit

Discount-Equipment.com is your online resource for quality parts & equipment.

Florida: **561-964-4949** Outside Florida TOLL FREE: **877-690-3101**

**Need parts?**

Click on this link: <http://www.discount-equipment.com/category/5443-parts/> and choose one of the options to help get the right parts and equipment you are looking for. Please have the machine model and serial number available in order to help us get you the correct parts. If you don't find the part on the website or on once of the online manuals, please fill out the request form and one of our experienced staff members will get back to you with a quote for the right part that your machine needs.

We sell worldwide for the brands: Genie, Terex, JLG, MultiQuip, Mikasa, Essick, Whiteman, Mayco, Toro Stone, Diamond Products, Generac Magnum, Airman, Haulotte, Barreto, Power Blanket, Nifty Lift, Atlas Copco, Chicago Pneumatic, Allmand, Miller Curber, Skyjack, Lull, Skytrak, Tsurumi, Husquvarna Target, , Stow, Wacker, Sakai, Mi-T- M, Sullair, Basic, Dynapac, MBW, Weber, Bartell, Bennar Newman, Haulotte, Ditch Runner, Menegotti, Morrison, Contec, Buddy, Crown, Edco, Wyco, Bomag, Laymor, Barreto, EZ Trench, Bil-Jax, F.S. Curtis, Gehl Pavers, Heli, Honda, ICS/PowerGrit, IHI, Partner, Imer, Clipper, MMD, Koshin, Rice, CH&E, General Equipment, ,AMida, Coleman, NAC, Gradall, Square Shooter, Kent, Stanley, Tamco, Toku, Hatz, Kohler, Robin, Wisconsin, Northrock, Oztec, Toker TK, Rol-Air, Small Line, Wanco, Yanmar

## SAW-I ENGINE (13HP HONDA)

ITEM	QTY.	PART#	DESCRIPTION
1	1	EN0650	13HP Honda QXC-Engine
2	4	HW0001	3/8" NC HHCS x 1-3/4" LG. w/ SAE F W & L.N (46038-02)
3	3	BL0400	3V Cog Belt (Matched Set)
4	1	BS0400	SH QD Bushing W/ 1" Diameter Hole
5	1	HW0001	1/4" Square Key X 2" LG (46038-05)
6	1	HW0001	Quick Splice Terminal (46038-06)
7	1	HW0001	1/4" I D Loom Clamp (46038-07)
8	2	PM0200	3 Groove, 3V Section Q.D. Sheave

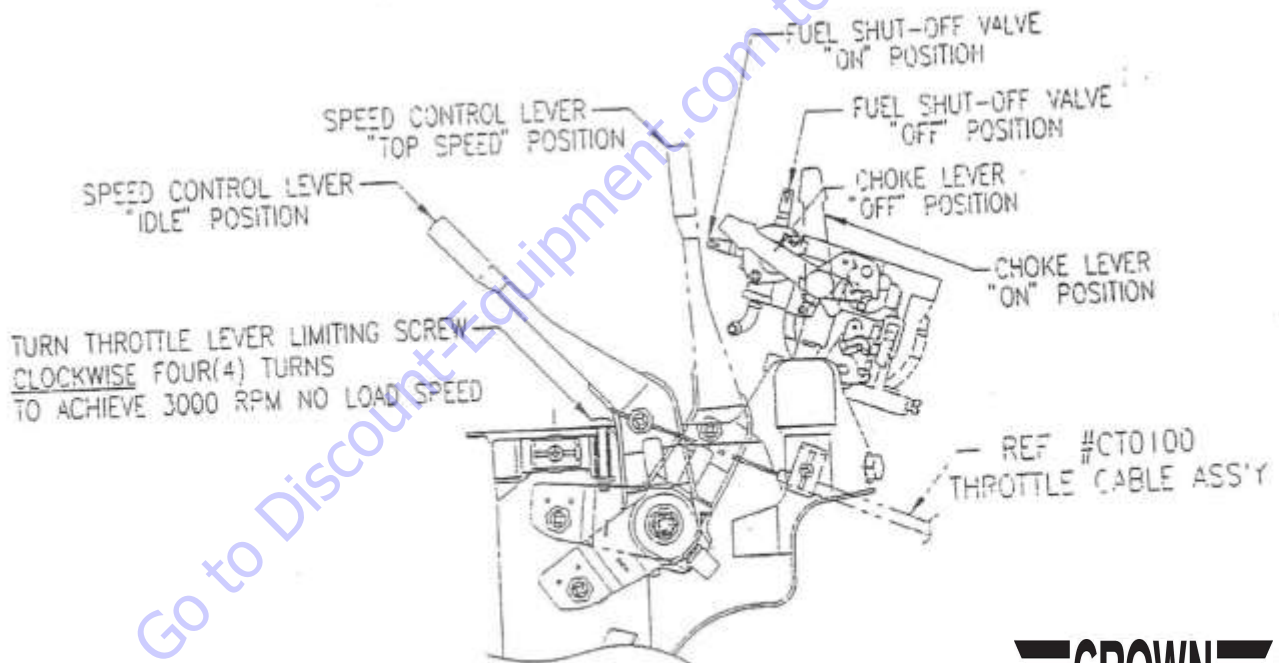

[www.Discount-Equipment.com](http://www.Discount-Equipment.com)