



**SKYJACK**

# PARTS MANUAL

**SJ45 AJ+**

ARTICULATING BOOM



**238271AAA**

March 2021

ANSI/CSA, CE, AS

# PARTS FINDER

**Search Website  
by Part Number**



**Search Manual  
Library For Parts  
Manual & Lookup Part  
Numbers – Purchase  
or Request Quote**

**Search Manuals**

Enter your information to help us find the right parts manual for your machine.

\* Brand:

\* Model:

\* Serial:

\* Part Number:

SEARCH

**Can't Find Part or  
Manual? Request Help  
by Manufacturer,  
Model & Description**

**Parts Order Form**

Please fill in the following information to help us find the right part for your machine.

Manufacturer:	<input type="text"/>
Model:	<input type="text"/>
Description:	<input type="text"/>
Part Number:	<input type="text"/>
Quantity:	<input type="text"/>
Notes:	<input type="text"/>

Discount-Equipment.com is your online resource for quality parts & equipment.

Florida: **561-964-4949** Outside Florida TOLL FREE: **877-690-3101**

**Need parts?**

Click on this link: <http://www.discount-equipment.com/category/5443-parts/> and choose one of the options to help get the right parts and equipment you are looking for. Please have the machine model and serial number available in order to help us get you the correct parts. If you don't find the part on the website or on one of the online manuals, please fill out the request form and one of our experienced staff members will get back to you with a quote for the right part that your machine needs.

We sell worldwide for the brands: Genie, Terex, JLG, MultiQuip, Mikasa, Essick, Whiteman, Mayco, Toro Stone, Diamond Products, Generac Magnum, Airman, Haulotte, Barreto, Power Blanket, Nifty Lift, Atlas Copco, Chicago Pneumatic, Allmand, Miller Curber, Skyjack, Lull, Skytrak, Tsurumi, Husquvarna Target, Stow, Wacker, Sakai, Mi-T-M, Sullair, Basic, Dynapac, MBW, Weber, Bartell, Bennar Newman, Haulotte, Ditch Runner, Menegotti, Morrison, Contec, Buddy, Crown, Edco, Wyco, Bomag, Laymor, EZ Trench, Bil-Jax, F.S. Curtis, Gehl Pavers, Heli, Honda, ICS/PowerGrit, IHI, Partner, Imer, Clipper, MMD, Koshin, Rice, CH&E, General Equipment, Amida, Coleman, NAC, Gradall, Square Shooter, Kent, Stanley, Tamco, Toku, Hatz, Kohler, Robin, Wisconsin, Northrock, Oztec, Toker TK, Rol-Air, APT, Wylie, Ingersoll Rand / Doosan, Innovatech, Con X, Ammann, Mecalac, Makinex, Smith Surface Prep, Small Line, Wanco, Yanmar

**This manual is for MEWPs with serial numbers:**

**SJ45 AJ+:** A301 100 001 - A301 199 999

**SJ45 AJ+:** B301 100 001 - B301 199 999

Please refer to the website ([www.discount-equipment.com](http://www.discount-equipment.com))  
for contact information, other serial numbers, the most  
recent technical manuals, and USB software.

Go to Discount-Equipment.com to order your parts

---

# Table of Contents

Foreword.....	7
General.....	7
Parts Ordering Information.....	7
Method of Listing.....	7
Quantities.....	7
How To Order Repair Parts.....	7
Recommended Service Parts.....	8
<b>Section 1 – Platform.....</b>	<b>11</b>
1.1 Platform with Drop Bars.....	12
1.2 Platform with Swing Gate.....	14
1.3 Railings.....	16
1.4 Platform Base.....	18
1.5 Swing Gate.....	20
1.6 Drop Bar.....	21
1.7 Platform Control Box.....	22
1.8 Boom / Turret Controller.....	26
1.9 Drive / Steer Controller.....	28
1.10 Riser Controller.....	30
1.11 Platform Terminal Strip.....	31
1.12 SGE.....	32
1.13 Footswitch.....	33
1.14 Power to Platform - CE & AS.....	34
1.15 Power to Platform - ANSI/CSA.....	36
<b>Section 2 – Boom.....</b>	<b>37</b>
2.1 Main & Fly Boom Assembly.....	38
2.2 Boom Limit Switches.....	42
2.3 Fly Boom.....	44
2.4 Riser.....	46
2.5 Cable Track.....	50
2.6 Jib.....	52
2.7 Jib Manifold.....	54
2.8 Rotary Actuator.....	56
<b>Section 3 – Cylinders.....</b>	<b>57</b>
3.1 Extension Cylinder.....	58
3.2 Lift Cylinder.....	60
3.3 Riser Cylinder Mounting.....	61

3.4	Riser Cylinder .....	62
3.5	Master Cylinder .....	63
3.6	Slave Cylinder .....	64
3.7	Jib Cylinder .....	65
3.8	Axle Lock Cylinder .....	66
<b>Section 4 – Turret .....</b>		<b>67</b>
4.1	Turret .....	68
4.2	Engine Tray .....	70
4.3	Counterweight .....	71
4.4	Cowling - Engine Side .....	72
4.5	Cowling - Controls Side .....	74
4.6	Cowling - Front .....	76
4.7	Manifold Hardware .....	78
4.8	Main Manifold .....	80
4.9	Brake Manifold .....	84
4.10	Fuel Tank - Kubota D1305 .....	86
4.11	Fuel Tank - Kubota WG972 .....	88
4.12	Hydraulic Tank .....	90
4.13	High Pressure Filter .....	92
4.14	Auxiliary Pump .....	93
4.15	Battery .....	94
4.16	Base Control Box .....	96
4.17	Base Terminal Strip .....	100
4.18	Grease Line .....	101
<b>Section 5 – Base .....</b>		<b>103</b>
5.1	Base .....	104
5.2	Axle Hardware .....	106
5.3	Rear Axle .....	108
5.4	Differential - Rear Axle .....	110
5.5	Brake - Rear Axle .....	112
5.6	Central Housing - Rear Axle .....	116
5.7	Gear Box - Rear Axle .....	118
5.8	Drive Motor .....	120
5.9	Front Axle .....	122
5.10	Differential - Front Axle .....	124
5.11	Central Housing - Front Axle .....	126
5.12	Steering Assembly .....	127
5.13	Trunnion - Front Axle .....	128
5.14	Drive Shaft .....	129
5.15	Tires .....	130

<b>Section 6 – Engines</b> .....	<b>131</b>
6.1 Kubota D1305 Engine .....	132
6.2 Air Intake & Exhaust - Kubota D1305 .....	136
6.3 Fuel Lines - Kubota D1305 .....	138
6.4 Kubota WG972 Engine .....	140
6.5 Air Intake & Exhaust - Kubota WG972 .....	144
6.6 Regulator/Vaporizer Mount .....	146
6.7 Propane Tank & Lines - Kubota WG972 .....	148
6.8 Fuel Lines - Kubota WG972 .....	150
6.9 Drive & System Pumps .....	152
<b>Section 7 – Electrical Harnesses</b> .....	<b>155</b>
7.1 Main Electrical & Fuel Level Switch Harnesses .....	156
7.2 Engine Harness - Kubota D1305 .....	158
7.3 Engine Fuse Box - Kubota D1305 .....	160
7.4 Engine Harness - Kubota WG972 .....	162
7.5 ECU Power Harness - Kubota WG972 .....	164
7.6 Fuel Pump Harness - Kubota WG972 .....	165
7.7 Battery Cables .....	166
7.8 Control & CANbus Cables .....	168
7.9 Jib & Platform Rotate Valve Harnesses .....	169
<b>Section 8 – Hydraulic Hoses</b> .....	<b>171</b>
8.1 Standard Hose Numbering System .....	172
8.2 Boom Hoses .....	174
8.3 Turret Hoses .....	176
8.4 Base Hoses .....	178
<b>Section 9 – Optional Equipment</b> .....	<b>181</b>
9.1 Flashing Light .....	182
9.2 Oil Quick Drain .....	183
9.3 Welder & Mount .....	184
9.4 Glazier Tray .....	188
9.5 Control Box Cover .....	190
9.6 Pipe Rack .....	192
9.7 Tool Caddy .....	194
9.8 Half-Height Platform Mesh .....	196
9.9 External Railing .....	200
9.10 Elevate Telematics .....	202
9.11 Elevate Telematics Subscription .....	204
<b>Section 10 – Labels</b> .....	<b>205</b>
10.1 Label Kit .....	206
10.2 Labels - Front and Back .....	207

---

10.3	Labels - Left & Right Sides .....	208
10.4	Labels - Platform .....	210
10.5	Labels - Controls Compartment .....	212
10.6	Labels - Engine Compartment .....	214

Go to [Discount-Equipment.com](http://Discount-Equipment.com) to order your parts

# Foreword

## General

The information contained in this manual is designed to aid the user in locating and identifying replacement parts. Component parts of various assemblies and subassemblies comprising the work platform are illustrated and accompanied by a descriptive parts list. Exploded drawings are used to show relative location of component parts in disassembly order. If a part cannot be found in this manual, contact Discount-equipment for assistance.

## Parts Ordering Information

When ordering replacement parts, the complete part number and description should be used to ensure proper identification and delivery of the desired item. This complete identification should also be used when requesting equipment information.

## Method of Listing

Parts are listed in order according to the reference number shown in the illustration, followed by a full description based upon the "NOUN FIRST" method. That is, the noun name of the part is listed first, then the modifying description information which serves to specifically identify the item. For example: PIN, Clevis.

Assemblies at the beginning of a parts list may be identified with a reference letter: A, B, C, etc. These letters are used to identify different configurations of the assembly. Individual parts in these lists have corresponding letters after their description to identify which assembly it is used in. If a part does not have a reference letter, it is used in all of the assemblies.

Bullets (•) are used to show the assembly structure, or parent/child relationship. A part listed at the beginning of the parts list without a bullet before the description is the main assembly, and all of the parts below it with one bullet are the subcomponent parts of that assembly. Two bullets denote a subcomponent of a subcomponent, etc.

### Example:

Main Assembly A

- Part 1 (subcomponent of Main Assembly A)
- Part 2 (subcomponent of Main Assembly A)
- • Part 3 (subcomponent of Part 2)

## Quantities

The quantities required to complete the assembly are given for each part. If the quantity is (AR), it is understood that the quantity may vary when the machine is equipped with certain options. Order quantity as needed.

## How To Order Repair Parts

1. Address all orders to Discount-equipment.
2. Specify model and serial number of the work platform (found on the serial number plate).
3. List the quantity needed.
4. List the length needed (if it is a bulk item).
5. List the part number and description as shown in this manual for each item.
6. Show the billing and shipping address and the name of the individual, if possible.
7. Suggest the best routing.

**Customer:** \_\_\_\_\_

**Dealer:** \_\_\_\_\_

**Model Number:** \_\_\_\_\_

**Serial Number:** \_\_\_\_\_

**Date Purchased:** \_\_\_\_\_



## Recommended Service Parts

Description	Year 1 Qty	Year 2 Qty	Year 3 Qty	Skyjack Part No.
<b>Engine - Kubota D1305</b>				
FILTER, Oil - inner	2	2	2	236071
CARTRIDGE, Oil filter	2	2	2	147129
FILTER, Fuel	2	2	2	236089
ELEMENT, Air cleaner	2	2	2	132913
THERMOSTAT	0	0	1	136109
BELT, Fan	0	0	1	236079
PUMP, Fuel transfer	1	1	1	236080
STARTER	0	0	1	236072
ALTERNATOR	0	0	1	236073
<b>Engine - Kubota WG972</b>				
ELEMENT, Air cleaner	2	2	2	132913
ALTERNATOR	0	0	1	237570
BELT, Fan	0	1	1	136114
ELEMENT, Fuel Filter	2	2	2	136118
PUMP, Fuel	1	1	1	163557
FILTER, LP	0	1	1	142300
FILTER, Oil	2	2	2	237654
SPARK PLUG	3	3	3	166642
STARTER	0	0	1	159216
THERMOSTAT	0	0	1	237573
<b>Electrical</b>				
BATTERY	2	2	2	144676
RELAY, Micro	5	5	5	931298
SOCKET, Micro relay	1	1	1	218997
SWITCH, Toggle	2	2	2	102853
SWITCH, Toggle	1	1	1	148988
SWITCH, Toggle	1	1	1	138278
SWITCH, Toggle	1	1	1	115747
SWITCH, Toggle	1	1	1	124446
SWITCH, Toggle	1	1	1	115574
BLOCK, N.C. Contact (red plunger, key switch and e-stop)	1	1	1	147053
BLOCK, N.O. Contact (black plunger, key switch)	1	1	1	166141
BLOCK, N.C. Contact (yellow plunger, key switch)	1	1	1	166142
SWITCH, Limit - riser up	0	1	1	199546

## Recommended Service Parts

Description	Year 1 Qty	Year 2 Qty	Year 3 Qty	Skyjack Part No.
SWITCH, Limit - boom extension	0	1	1	207016
SWITCH, Limit - boom angle	0	1	1	207017
SWITCH, Limit - direction sensing	0	1	1	199486
COIL, Valve	0	1	1	159819
KIT, Drive/steer joystick handle	0	1	1	141338
<b>Hydraulic</b>				
ELEMENT, High pressure filter - hydraulic	1	1	1	161947
ELEMENT, Return filter - hydraulic	2	2	2	161949
SEAL KIT, Extension cylinder - SJ46AJ	0	0	1	154537
SEAL KIT, Extension cylinder - SJ51AJ	0	0	1	154655
SEAL KIT, Lift cylinder	0	0	1	154528
SEAL KIT, Riser cylinder	0	0	1	154562
SEAL KIT, Master cylinder	0	0	1	154524
SEAL KIT, Slave cylinder	0	0	1	152254
SEAL KIT, Jib cylinder	0	0	1	154549
SEAL KIT, Axle lockout cylinder	0	0	1	154557
SEAL KIT, Rotary actuator	0	0	1	144709
SEAL KIT, Steer cylinder	0	0	1	168050
<b>Boom</b>				
SHIM, 16 gauge (top)	0	1	1	148829
SHIM, 20 gauge (top)	0	1	1	148830
SHIM, 16 gauge (side)	0	1	1	148837
SHIM, 20 gauge (side)	0	1	2	148838
PAD, Wear - top	0	1	2	148827
PAD, Wear - bottom	0	1	2	148826
<b>Cowling</b>				
LATCH, Flexible draw	2	2	2	144002
<b>Axles</b>				
SEAL, Differential pinion - front axle	0	0	1	140976
SEAL, Planetary hub - front and rear axle	0	0	1	154631
O-RING, Planetary hub - front axle	0	0	1	140970
SEAL, Inner axle shaft - front axle	0	0	1	154625
SEAL, Outer axle shaft - front axle	0	0	1	154625
SEAL, Differential pinion - rear axle	0	0	1	141074
O-RING, Planetary hub - rear axle	0	0	1	140970



# Section 1 – Platform

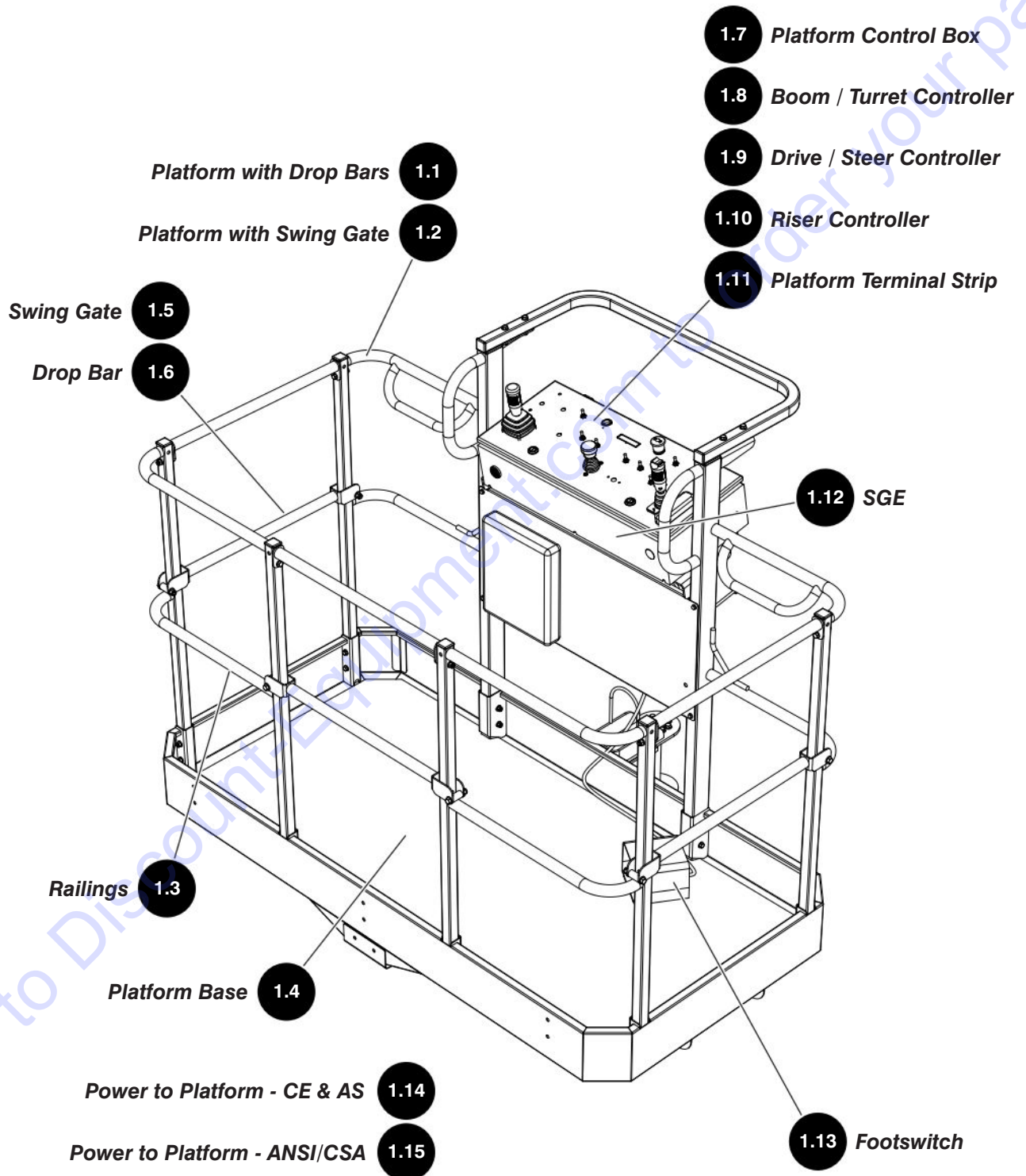

# 1.1 Platform with Drop Bars

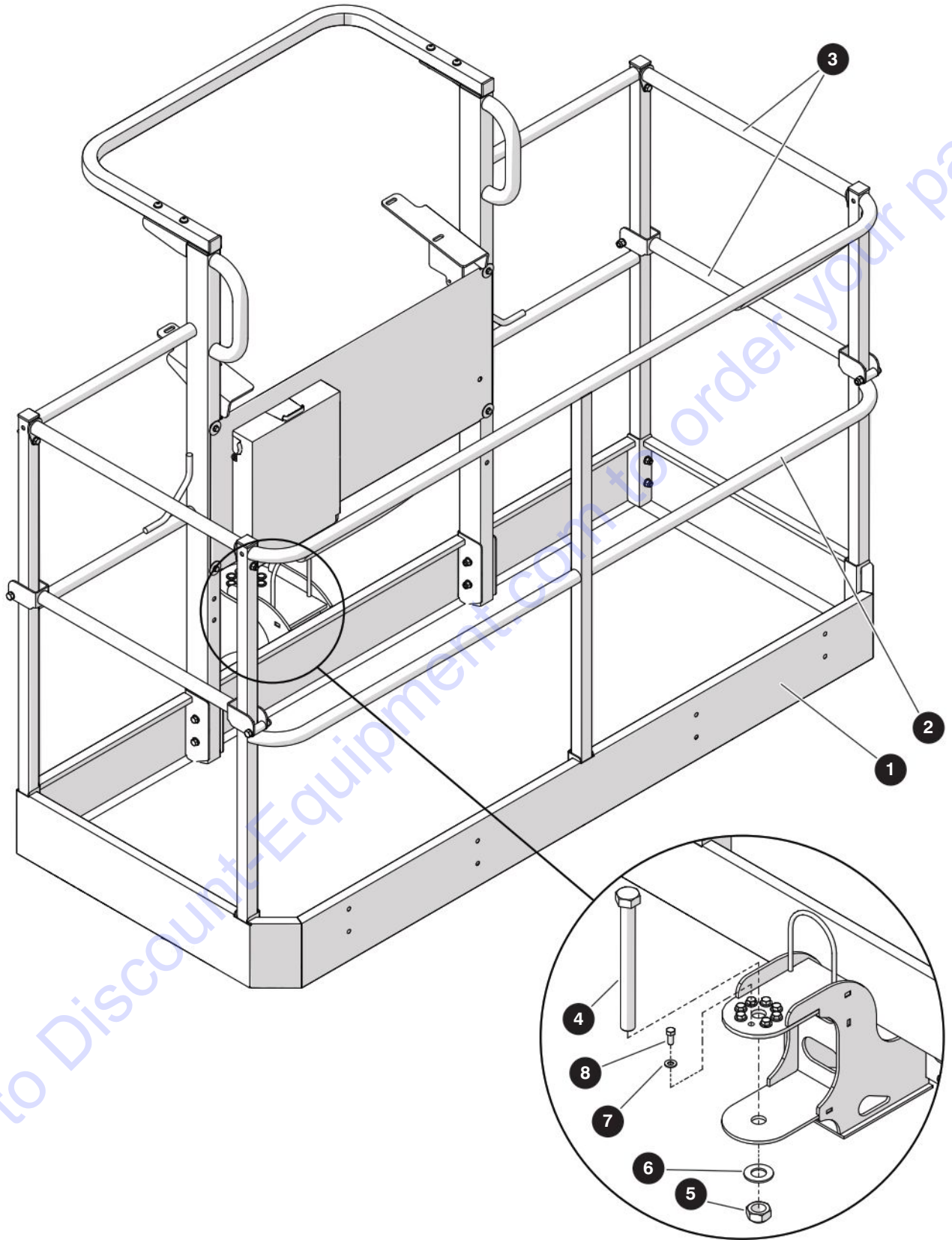

M163273AB

238271AAA

SJ45 AJ+

## 1.1 Platform with Drop Bars

Index No.	Skyjack Part No.	Qty.	Description
-	218723	1	PLATFORM ASSEMBLY - 6' with Drop Bar
-	218725	1	PLATFORM ASSEMBLY - 5' with Drop Bar
1	(Ref.)	1	<ul style="list-style-type: none"> <li>RAILINGS (For components, refer to 1.3 Railings)</li> </ul>
2	(Ref.)	1	<ul style="list-style-type: none"> <li>PLATFORM BASE (For components, refer to 1.4 Platform Base)</li> </ul>
3	(Ref.)	2	<ul style="list-style-type: none"> <li>GATE, Drop (For components, refer to 1.6 Drop Bar)</li> </ul>
4	138696	1	<ul style="list-style-type: none"> <li>BOLT, Hex head (1"-8 x 10-1/2" Grade 8, zinc)</li> </ul>
5	138559	1	<ul style="list-style-type: none"> <li>NUT, Torque lock (1"-8 Grade 8)</li> </ul>
6	102646	1	<ul style="list-style-type: none"> <li>WASHER, Flat (1")</li> </ul>
7	125959	8	<ul style="list-style-type: none"> <li>WASHER, Flat (3/8")</li> </ul>
8	139193	8	<ul style="list-style-type: none"> <li>BOLT, Hex head (3/8"-16 x 0.78", Grade 8)</li> </ul>
9	173200	1	MANUAL OF RESPONSIBILITIES (not shown)

## 1.2 Platform with Swing Gate

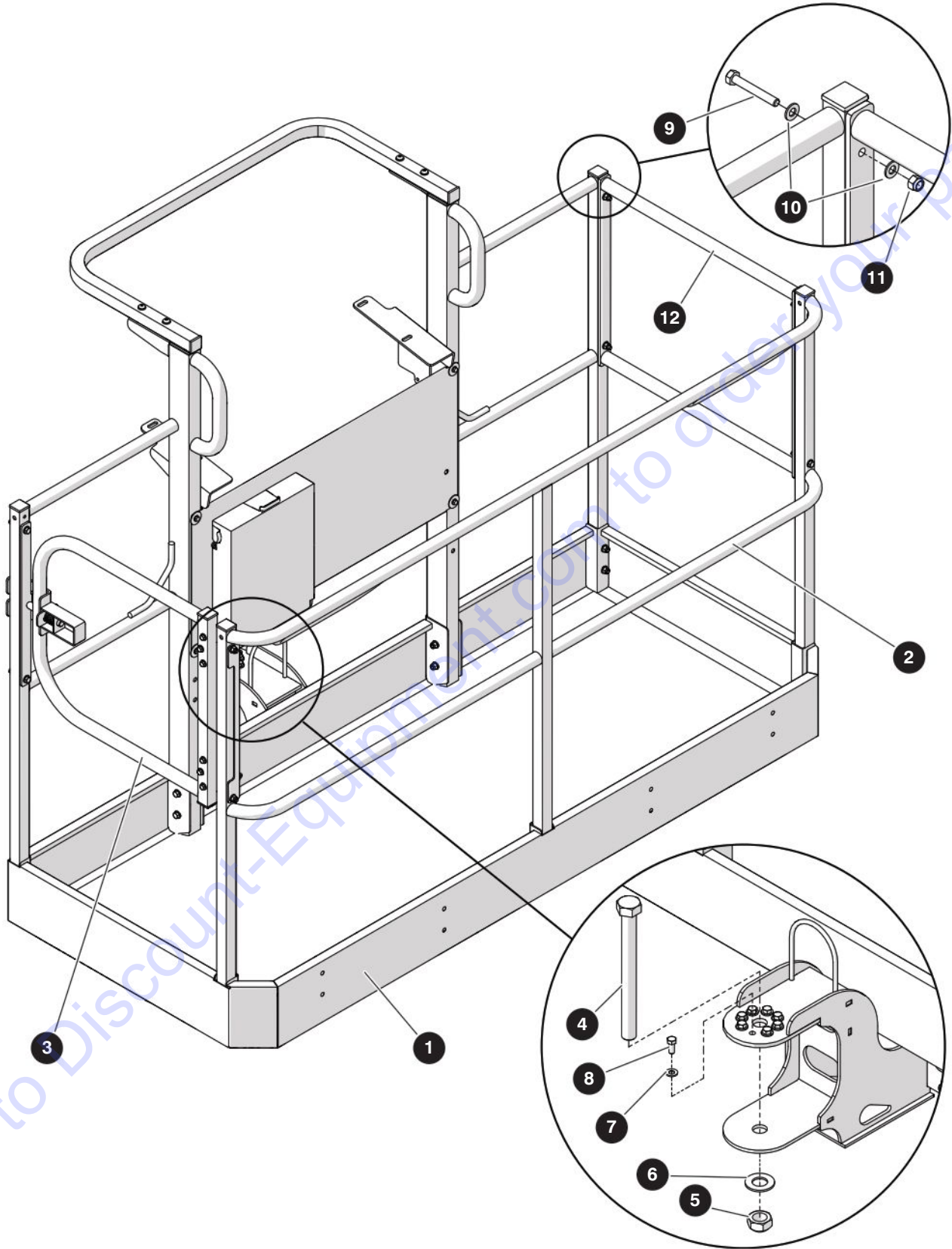

M163274AB

238271AAA

SJ45 AJ+

## 1.2 Platform with Swing Gate

Index No.	Skyjack Part No.	Qty.	Description
-	218724	1	PLATFORM ASSEMBLY - <b>6' with Swing Gate</b>
-	218726	1	PLATFORM ASSEMBLY - <b>5' with Swing Gate</b>
1	(Ref.)	1	<ul style="list-style-type: none"> <li>RAILINGS (For components, refer to 1.3 Railings)</li> </ul>
2	(Ref.)	1	<ul style="list-style-type: none"> <li>PLATFORM BASE (For components, refer to 1.4 Platform Base)</li> </ul>
3	(Ref.)	1	<ul style="list-style-type: none"> <li>SWING GATE (For components, refer to 1.5 Swing Gate)</li> </ul>
4	138696	1	<ul style="list-style-type: none"> <li>BOLT, Hex head (1"-8 x 10-1/2" Grade 8, zinc)</li> </ul>
5	138559	1	<ul style="list-style-type: none"> <li>NUT, Torque lock (1"-8 Grade 8)</li> </ul>
6	102646	1	<ul style="list-style-type: none"> <li>WASHER, Flat (1")</li> </ul>
7	125959	8	<ul style="list-style-type: none"> <li>WASHER, Flat (3/8")</li> </ul>
8	139193	8	<ul style="list-style-type: none"> <li>BOLT, Hex head (3/8"-16 x 0.78", Grade 8)</li> </ul>
9	103866	4	<ul style="list-style-type: none"> <li>BOLT, Hex head (5/16"-18 x 2-1/4", gr 5)</li> </ul>
10	103996	8	<ul style="list-style-type: none"> <li>WASHER, Flat (5/16")</li> </ul>
11	103984	4	<ul style="list-style-type: none"> <li>NUT, Lock (5/16"-18, gr 5)</li> </ul>
12	218716	1	<ul style="list-style-type: none"> <li>RAILING, Side</li> </ul>
13	173200	1	MANUAL OF RESPONSIBILITIES (not shown)



# 1.3 Railings

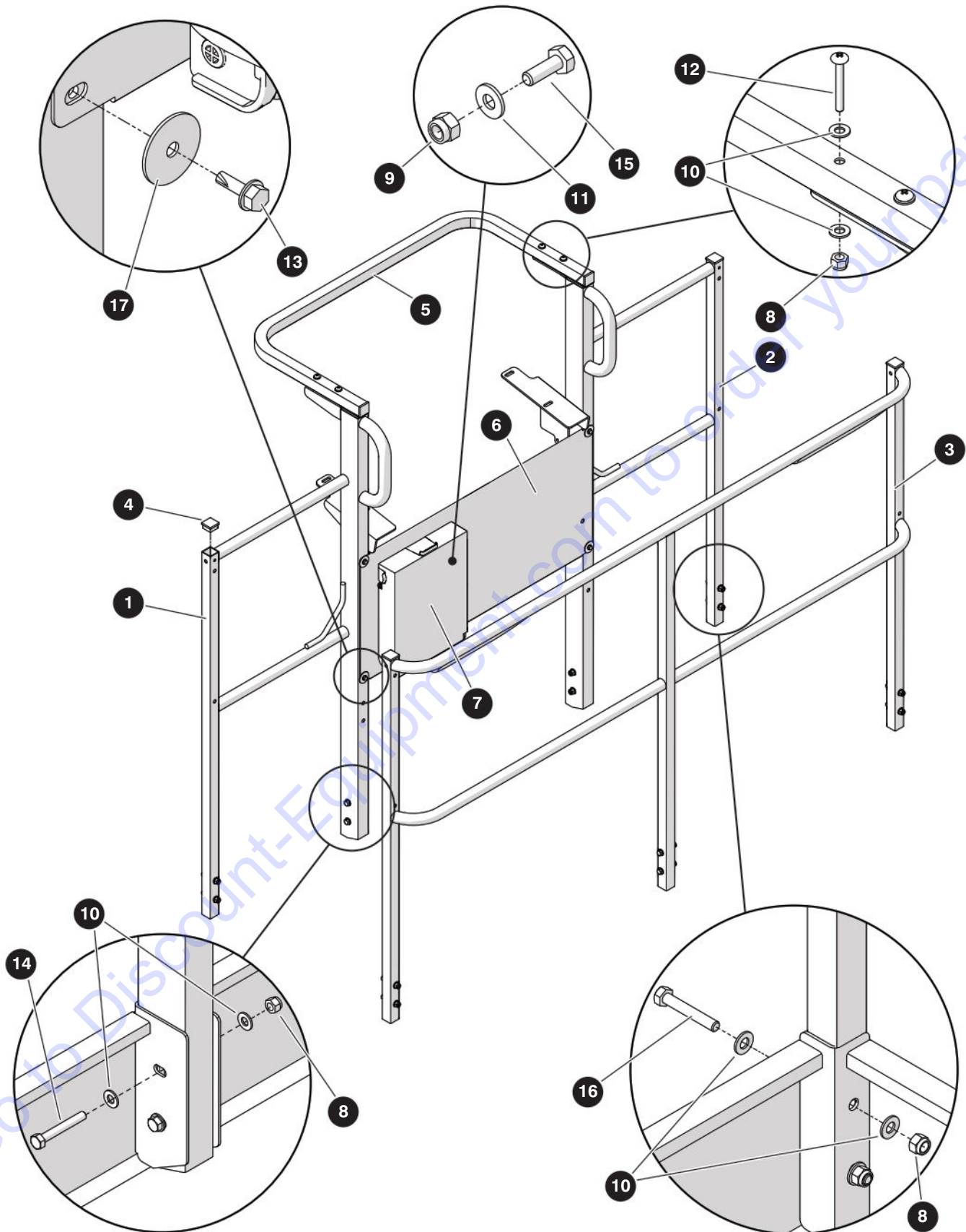

M218716AB

238271AAA

SJ45 AJ+

## 1.3 Railings

Index No.	Skyjack Part No.	Qty.	Description
<b>A</b>	-	1	RAILINGS - <b>6' platform</b>
<b>B</b>	-	1	RAILINGS - <b>5' platform</b>
1	160997	1	• RAILING, Front left, <b>A</b>
	160996	1	• RAILING, Front left, <b>B</b>
2	160999	1	• RAILING, Front right, <b>A</b>
	160998	1	• RAILING, Front right, <b>B</b>
3	165820	1	• RAILING, Rear, <b>A</b>
	165823	1	• RAILING, Rear, <b>B</b>
4	100702	6	• CAP, Plastic end
5	149098	1	• RAILING, Front
6	159586	1	• PLATE, Front guard
7	198789	1	• MANUAL BOX
8	103984	18	• NUT, Hex lock (5/16"-18 Grade 5, nylon)
9	115649	4	• NUT, Hex lock (1/4"-20 Grade 5, nylon)
10	103996	36	• WASHER, Flat (5/16")
11	103995	4	• WASHER, Flat (1/4")
12	139008	4	• SCREW, Round head machine (5/16"-18 x 2")
13	103632	4	• SCREW, Hex head self tapping (1/4"-14 x 3/4")
14	103866	4	• BOLT, Hex head (5/16"-18 x 2 1/4" Grade 5)
15	103856	4	• BOLT, Hex head (1/4"-20 x 3/4" Grade 5)
16	103865	10	• BOLT, Hex head (5/16"-18 x 2" Grade 5)
17	700598	4	• WASHER, Fender
18	207981	1	• BAG, Resealable (not shown)
19	173200	1	MANUAL, Manual of responsibilities (not shown)

## 1.4 Platform Base

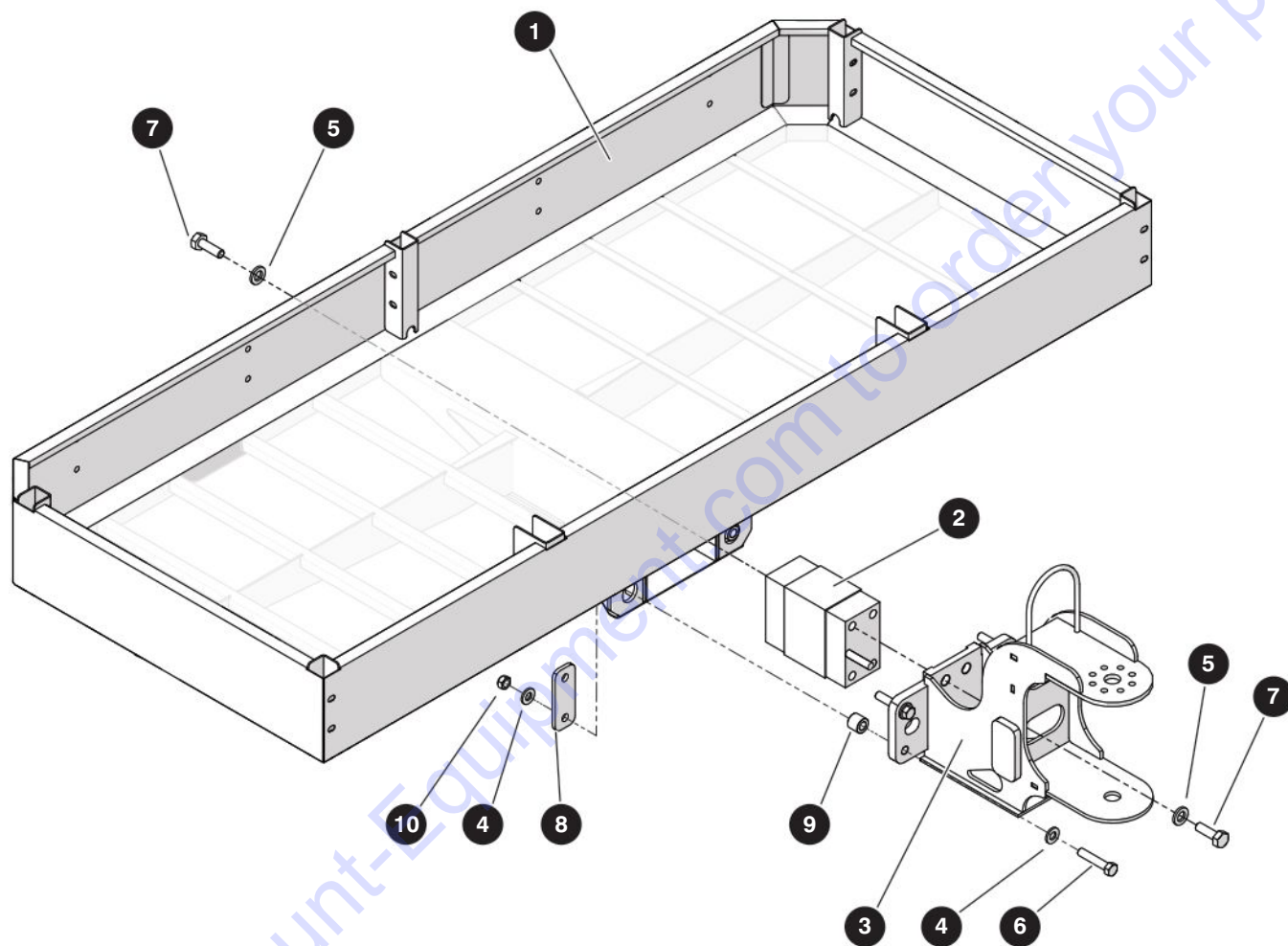

M218716AB-1

238271AAA

SJ45 AJ+

# 1.4 Platform Base

Index No.	Skyjack Part No.	Qty.	Description
1	218664	1	• PLATFORM BASE - <b>6' platform</b>
	218678	1	• PLATFORM BASE - <b>5' platform</b>
2	218368	1	• LOAD CELL, CAN MOBA
3	168230	1	• MOUNT, Rotary Actuator
4	104379	8	• WASHER, Flat hardened (1/2")
5	144329	8	• WASHER, Flat hardened (M16)
6	144575	4	• BOLT, Hex head (1/2"-13 x 2-1/2" gr 8)
7	144502	8	• BOLT, Hex head (M16 x 1.5 x 45 gr 8.8)
8	144365	2	• WASHER, Safety
9	144574	4	• SPACER, Load cell
10	138791	4	• NUT, Torque lock (1/2"-13 gr C)

## 1.5 Swing Gate

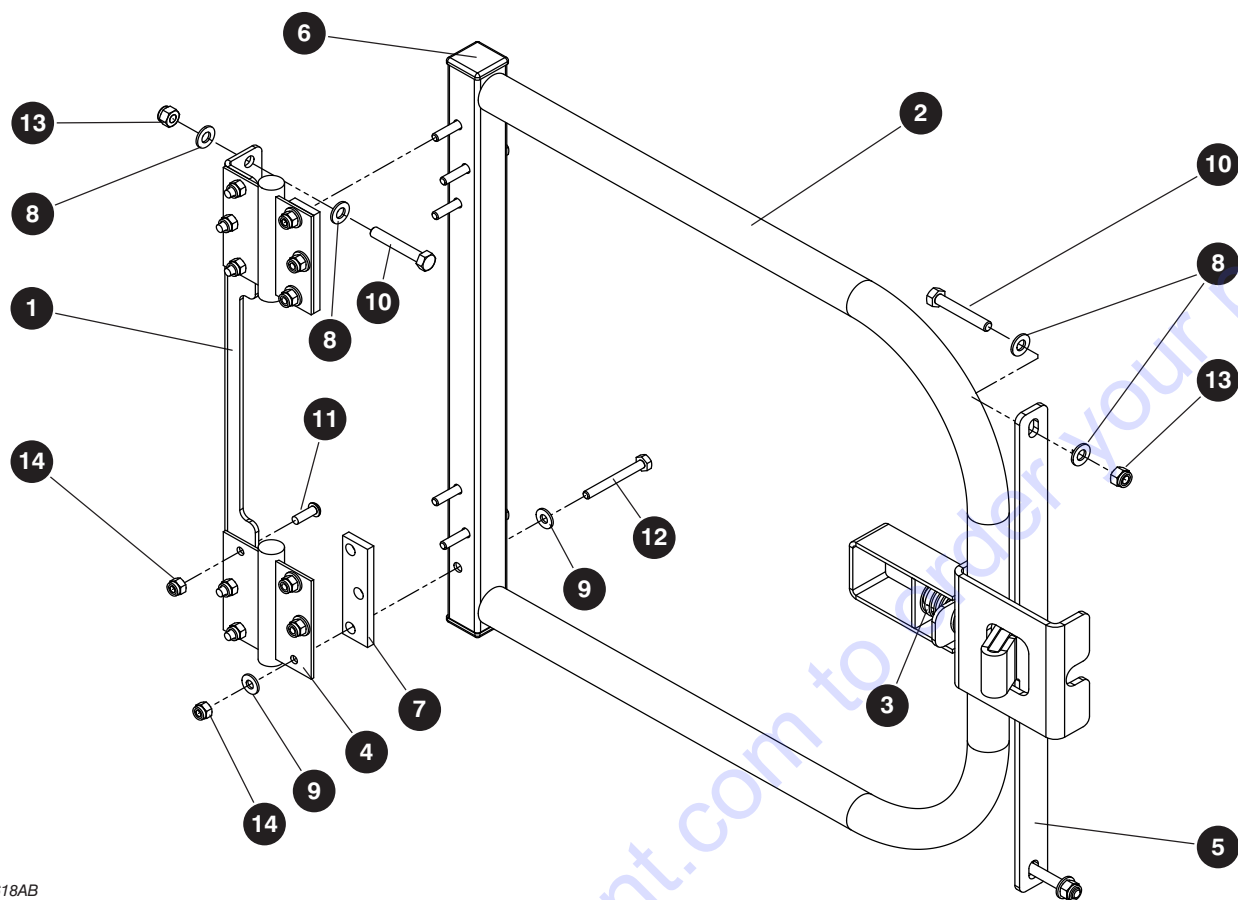

M164618AB

Index No.	Skyjack Part No.	Qty.	Description
<b>A</b>	164589	1	SWING GATE ASSEMBLY (30" x 60")
<b>B</b>	164618	1	SWING GATE ASSEMBLY (30" x 72")
1	164590	1	• BRACKET, Hinge mounting
2	164593	1	• WELDMENT, Gate <b>A</b>
	164619	1	• WELDMENT, Gate <b>B</b>
3	110824	1	• PIN LATCH, Door spring
4	209527	2	• HINGE, Spring
5	166288	1	• PLATE, Locking <b>A</b>
5	166287	1	• PLATE, Locking <b>B</b>
6	100702	2	• CAP, End
7	164592	2	• TAB, Hinge
8	103996	10	• WASHER, Flat (5/16")
9	103995	12	• WASHER, Flat (1/4")
10	103865	5	• BOLT, Hex head (5/16"-18 x 2.00", Grade 5)
11	139168	6	• BOLT, Button head cap screw (1/2"-20 x 0.75", Grade 5)
12	103862	6	• BOLT, Hex head (1/4"-20 x 2.25", Grade 5)
13	103984	5	• NUT, Hex head nylon lock (5/16"-18, Grade 5)
14	115649	12	• NUT, Hex head nylon lock (1/4"-20, Grade 5)

## 1.6 Drop Bar

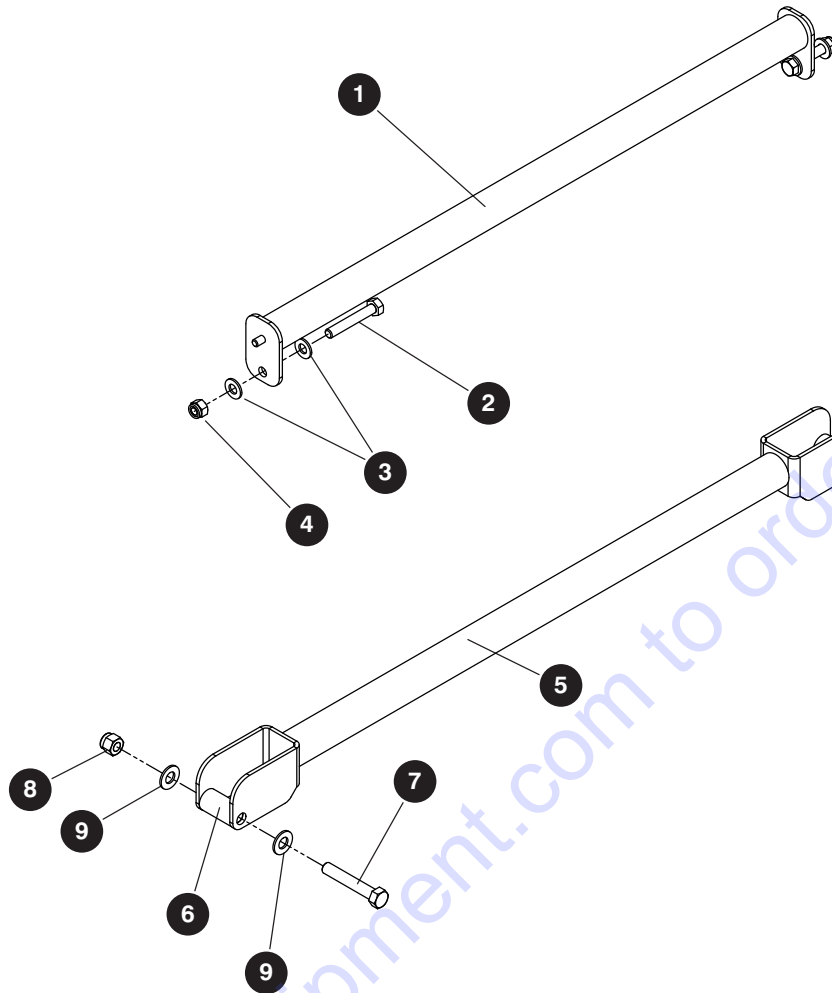

M160707AC

Index No.	Skyjack Part No.	Qty.	Description
-	160707	1	DROP GATE ASSEMBLY
1	160708	1	• WELDMENT, Tie bar
2	103865	2	• BOLT, Hex head (5/16"-18 x 2.00", Grade 5)
3	103996	4	• WASHER, Flat (5/16")
4	103984	2	• NUT, Hex head nylon lock (5/16"-18, Grade 5)
-	162965	1	• DROP BAR ASSEMBLY
5	162958	1	• • WELDMENT, Drop bar
6	154386	2	• • SPACER (3/8" ID x 0.75" OD x 1.375" long)
7	103872	2	• • BOLT, Hex head (3/8"-16 x 2.25", Grade 5)
8	104606	2	• • NUT, Hex head nylon lock (3/8"-16, Grade 5)
9	103472	4	• • WASHER, Flat (3/8")

# 1.7 Platform Control Box

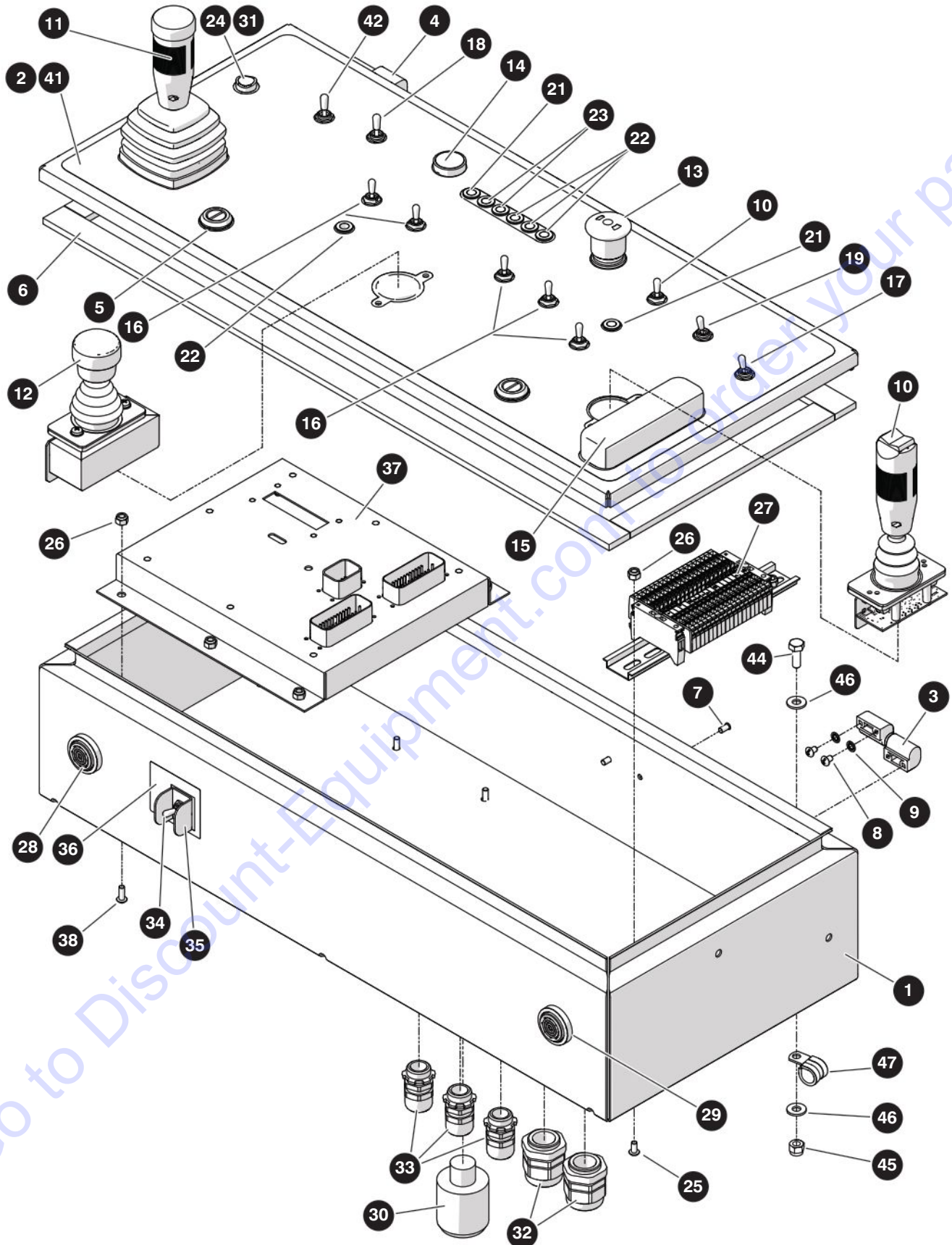

M218375AF

238271AAA

22

SJ45 AJ+

SKYJACK

## 1.7 Platform Control Box

Index No.	Skyjack Part No.	Qty.	Description
-	218375	1	PLATFORM CONTROL BOX
-	218345	1	• CONTROL BOX, Platform
1	218346	1	• • BODY, Control box
2	218421	1	• • LID, Control box
3	149384	1	• • HINGE, Nylon (Left hand)
4	149385	1	• • HINGE, Nylon (Right hand)
5	138715	2	• • LATCH, Slotted door
6	138334	1	• • WEATHER STRIP, Cut
7	159879	2	• • STUD, Aluminum (#10-32 x 3/8")
8	103959	8	• • SCREW, Round head machine (#10-24 x 1/4")
9	163512	8	• • WASHER, Lock (#10)
10	(Ref.)	1	• CONTROLLER, Drive / Steer (For components, refer to 1.9 Drive / Steer Controller)
11	(Ref.)	1	• CONTROLLER, Boom / Turret (For components, refer to 1.8 Boom / Turret Controller)
12	(Ref.)	1	• CONTROLLER, Riser (For components, refer to 1.10 Riser Controller)
13	144647	1	• SWITCH ASSEMBLY, PLATFORM E-STOP
	147056	1	• • LATCH, Mounting
	147229	1	• • SWITCH, LED Block (Red)
	147053	2	• • BLOCK, NC Contact
	147051	1	• • SWITCH HEAD, Emergency stop
14	144648	1	• SWITCH ASSEMBLY, HORN PUSHBUTTON
	147056	1	• • LATCH, Mounting
	147054	1	• • BLOCK, NO Contact
	147058	1	• • SWITCH HEAD, Horn pushbutton
15	149402	1	• HANDREST
16	102853	6	• SWITCH, Toggle (1NT1-7)
17	115747	1	• SWITCH, Toggle (1NT1-3)
18	124446	1	• SWITCH, Toggle (2NT1-50)
19	115574	1	• SWITCH, Toggle (1NT1-2)
20	144016	9	• SEAL, Panel bushing (not shown)
21	213303	2	• LIGHT, LED - green
22	213307	4	• LIGHT, LED - amber
23	213308	2	• LIGHT, LED - red
24	166087	1	• PUSHBUTTON, Yellow
25	115545	2	• SCREW, Round head machine (#10-32 x 3/8")
26	300450	8	• NUT, Hex lock (#10-32 Grade 5, nylon)
27	(Ref.)	1	• PLATFORM TERMINAL STRIP (For components, refer to 1.11 Platform Terminal Strip)
28	103057	1	• BEEPER, 4-28VDC Slow pulsing
29	144387	1	• ALARM, Overload
30	166110	1	• ALARM/FLASHER, 12V red light
31	166086	1	• BODY, Contact block - N/O yellow LED 12-24 V
32	116266	2	• CONNECTOR, Strain relief (PG21)
33	103036	3	• CONNECTOR, Strain relief (1/2")
34	218481	1	• SWITCH, Toggle (1NT1-3D)



# 1.7 Platform Control Box

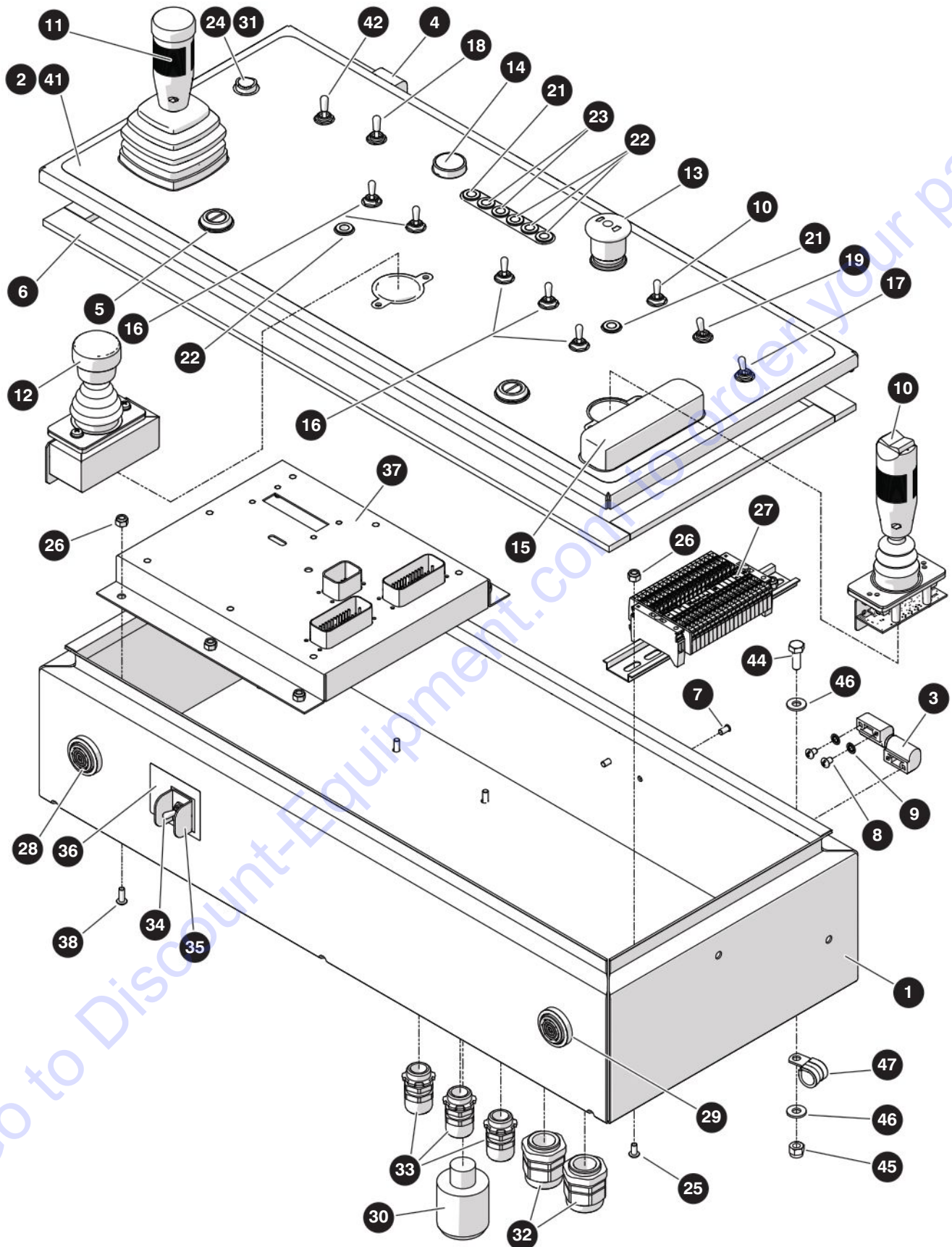

M218375AF

238271AAA

SJ45 AJ+

## 1.7 Platform Control Box

Index No.	Skyjack Part No.	Qty.	Description
35	111181	1	• GUARD, Toggle switch
36	231398	1	• LABEL, Override switch
37	218382	1	• MODULE, Slave
	218277	1	• • SERVICE TOOL
	218276	1	• • • HARNESS, SMB1 to peak
	218278	1	• • • ADAPTER, PCAN-USB
38	103962	6	• SCREW, Round head machine (#10-32 x 1/2")
39	103855	2	• BOLT, Hex head (1/4"-20 x 1/2" Grade 5)
40	103995	2	• WASHER, Flat (1/4")
41	(Ref.)	1	• LABEL, Platform controls (For components, refer to 10.4 Labels - Platform)
42	115747	1	SWITCH, Toggle (dual fuel) - <b>Kubota WG972</b>
43	144016	1	SEAL, Panel bushing (not shown) - <b>Kubota WG972</b>
44	103856	4	BOLT, Hex head (1/4"-20 x 3/4" gr 5)
45	115649	4	NUT, Hex head nylon (1/4"-20 gr 5)
46	103995	8	WASHER, Flat (1/4")
47	103024	1	CLIP, Single (G8)

# 1.8 Boom / Turret Controller

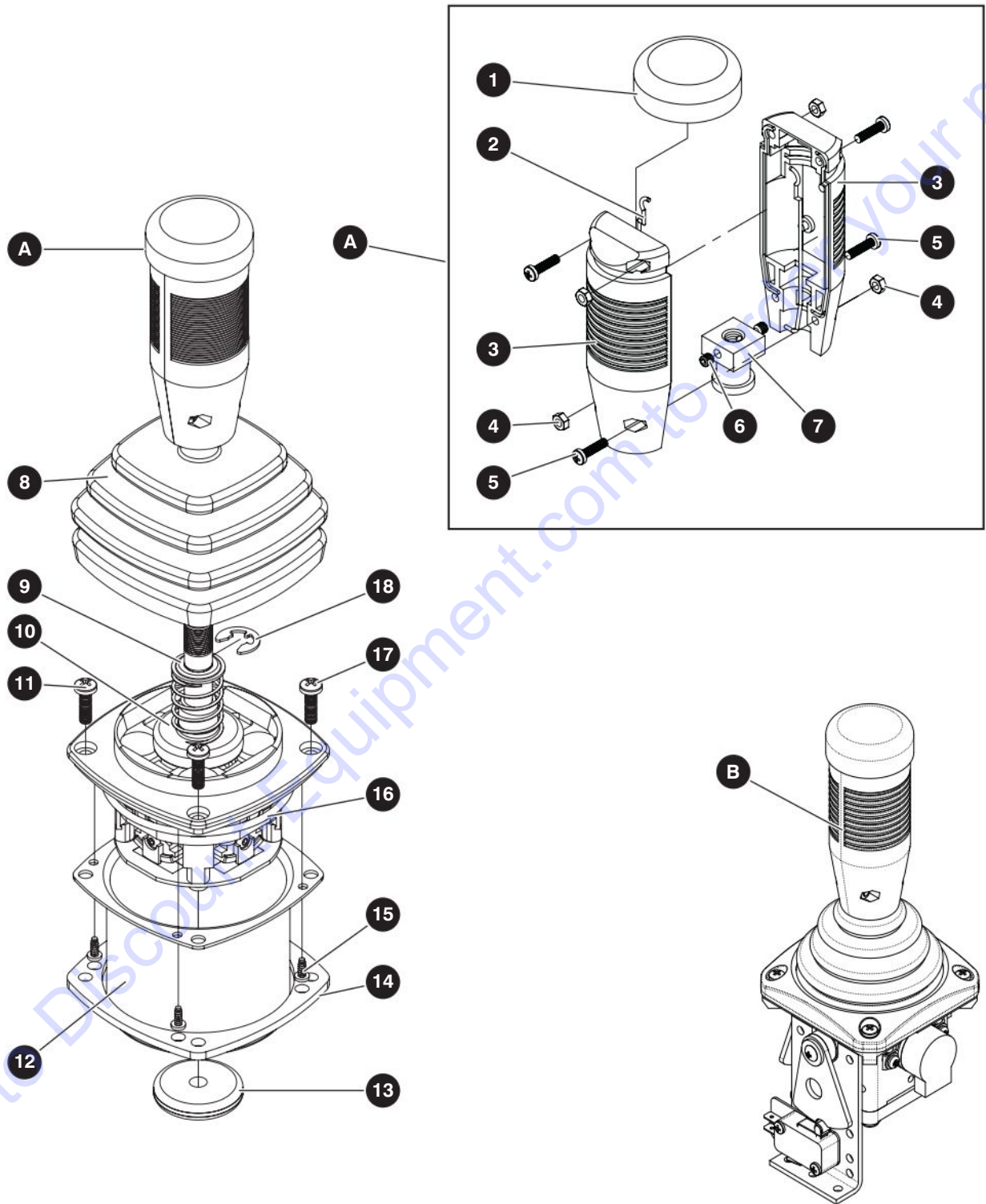

M138225AA\_M220628AA

238271AAA

SJ45 AJ+

## 1.8 Boom / Turret Controller

Index No.	Skyjack Part No.	Qty.	Description
<b>A</b>	138225	1	BOOM / TURRET CONTROLLER ASSEMBLY (DUAL AXIS)
1	141326	1	• CAP, Rubber
2	141327	2	• GASKET
3	141325	2	• HANDLE, Half
4	141328	4	• NUT
5	141329	4	• SCREW
6	141331	2	• SCREW, Set
7	141330	1	• COUPLING, (10 mm)
8	141313	1	• BOOT
9	141323	1	• WASHER, Retainer
10	141315	1	• SHOE, Spring
11	141321	4	• SCREW, Mounting (M4)
12	141316	1	• CAN, Enclosure
13	141320	1	• GROMMET, Rubber
14	141317	1	• GASKET, Mounting
15	141319	4	• SCREW
16	141318	1	• O-RING
17	141324	1	• SPRING, Compression
18	141322	1	• CLIP, Retainer
19	216879	1	• CONNECTOR, Male (4-pin) (not shown)
20	216880	1	• CONNECTOR, Female (4-pin) (not shown)
<b>B</b>	220628	1	RISER BOOM CONTROLLER (Single Axis) - Potentiometer style - <b>Optional</b>

# 1.9 Drive / Steer Controller

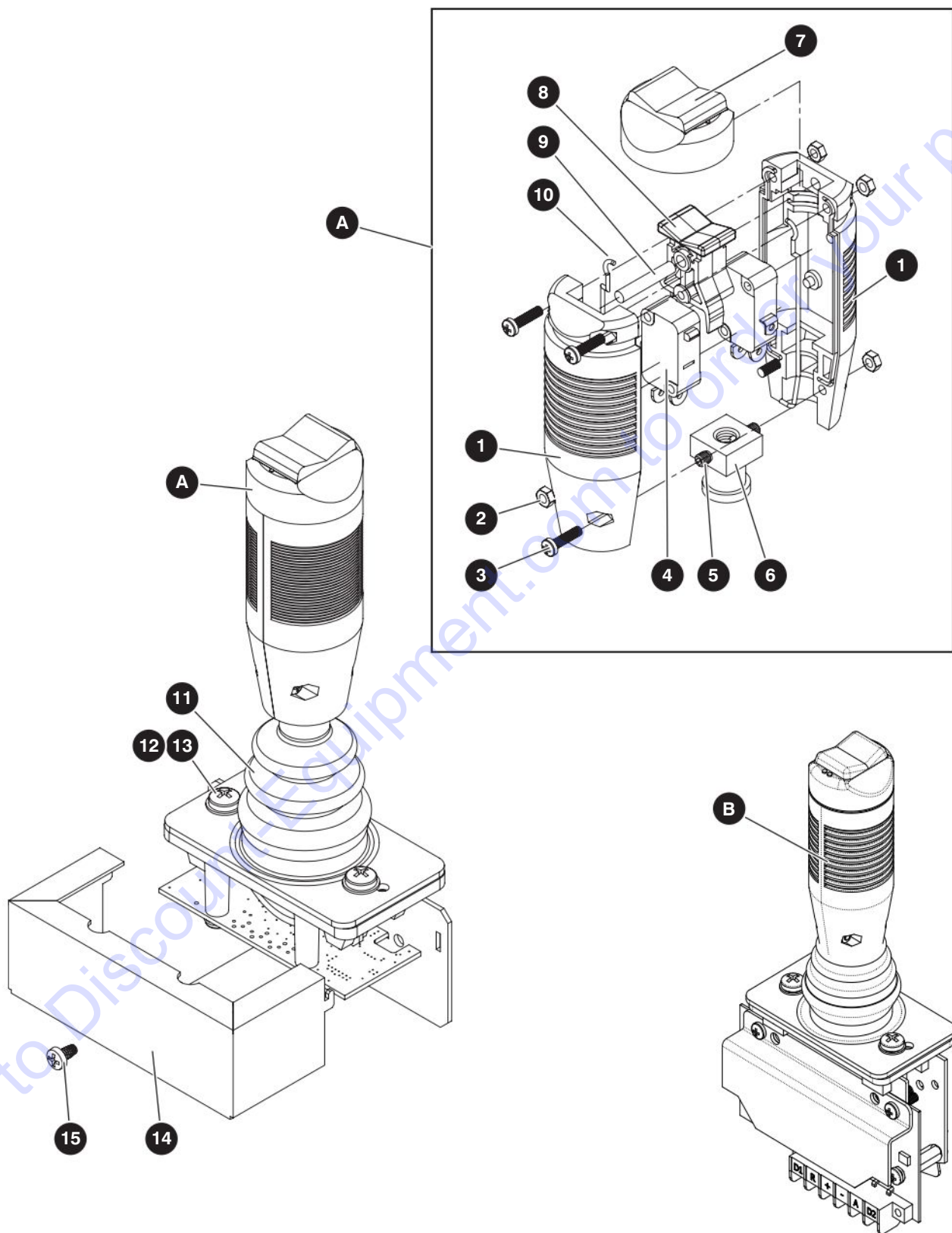

M138224AA\_M220627AA

238271AAA

SJ45 AJ+

## 1.9 Drive / Steer Controller

Index No.	Skyjack Part No.	Qty.	Description
<b>A</b>	138224	1	DRIVE / STEER CONTROLLER ASSEMBLY (SINGLE AXIS)
1	141338	2	• HANDLE, Half
2	141328	4	• NUT
3	141329	4	• SCREW
4	141342	2	• MICROSWITCH
5	141331	2	• SCREW, Set
6	141343	1	• COUPLING, (8 MM)
7	141339	1	• CAP, Rubber
8	141340	1	• ROCKER
9	141341	1	• ROCKER, Axle
10	141327	2	• GASKET
11	141334	1	• BOOT ASSEMBLY, Standard
12	141336	2	• SCREW Mounting
13	141335	2	• WASHER, Mounting
14	141333	1	• ENCLOSURE
15	141337	1	• SCREW, Enclosure
<b>B</b>	220627	1	DRIVE / STEER CONTROLLER (SINGLE AXIS) - Potentiometer style - <b>Optional</b>

## 1.10 Riser Controller

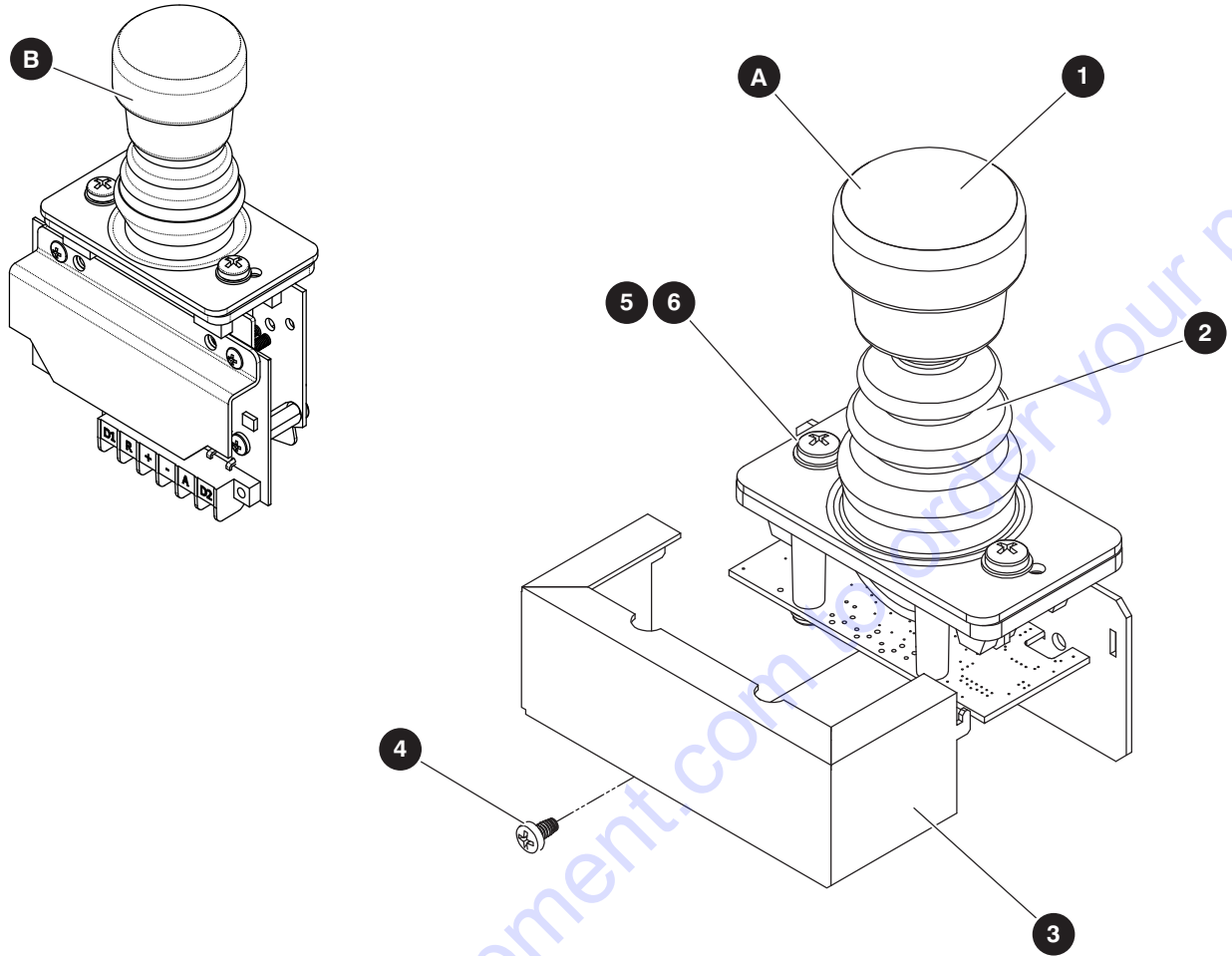

M148707AA\_M220626AA

Index No.	Skyjack Part No.	Qty.	Description
<b>A</b>	148707	1	RISER BOOM CONTROLLER (Single Axis)
1	154648	1	• CAP, Handle
2	141334	1	• BOOT ASSEMBLY, Standard
3	141333	1	• ENCLOSURE
4	141337	1	• SCREW, Enclosure
5	141336	2	• SCREW, Mount
6	141335	2	• WASHER, Mount
<b>B</b>	220626	1	RISER BOOM CONTROLLER (Single Axis) - Potentiometer style - <b>Optional</b>

## 1.11 Platform Terminal Strip

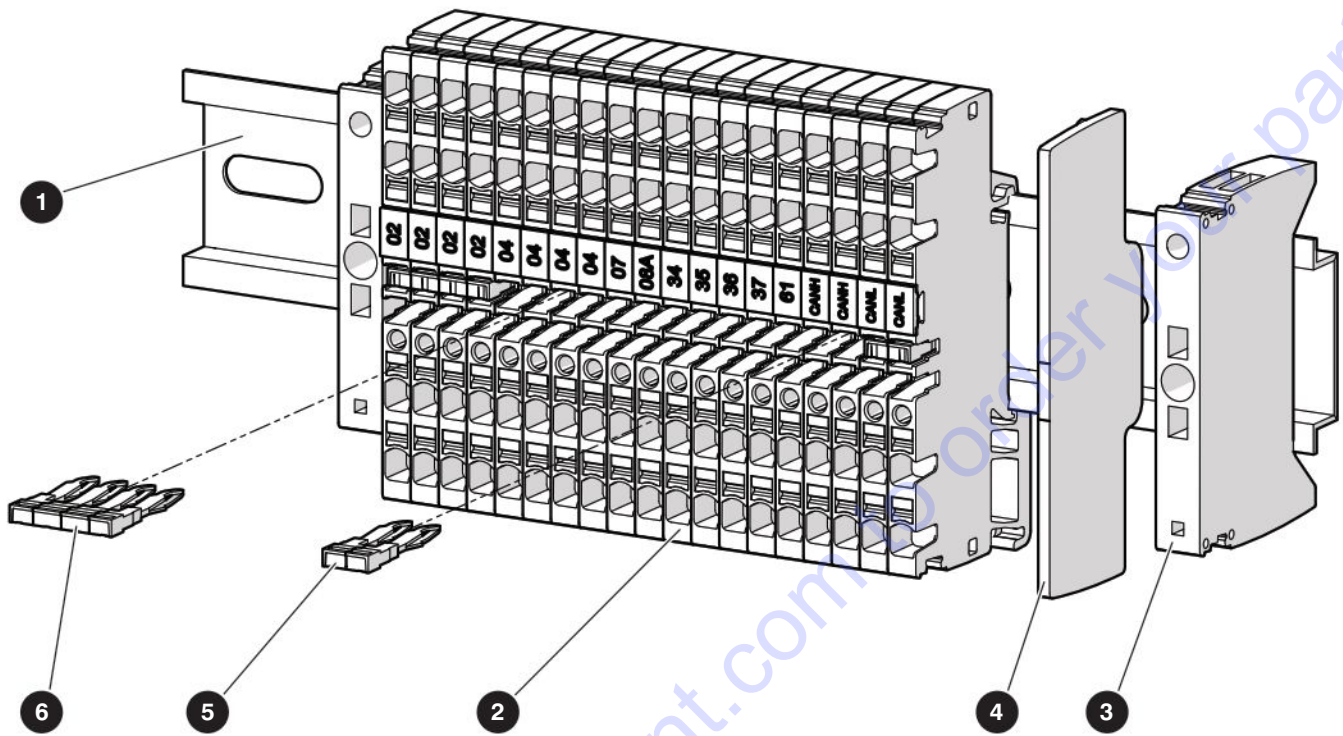

M218402AD

Index No.	Skyjack Part No.	Qty.	Description
-	218402	1	PLATFORM TERMINAL STRIP
1	233337	205 mm	• RAIL
2	233338	19	• BLOCK, Terminal
3	233341	2	• PLATE, End
4	233342	1	• PLATE, Separator
5	233343	2	• JUMPER, 2-pin
6	233344	2	• JUMPER, 4-pin



# 1.12 SGE

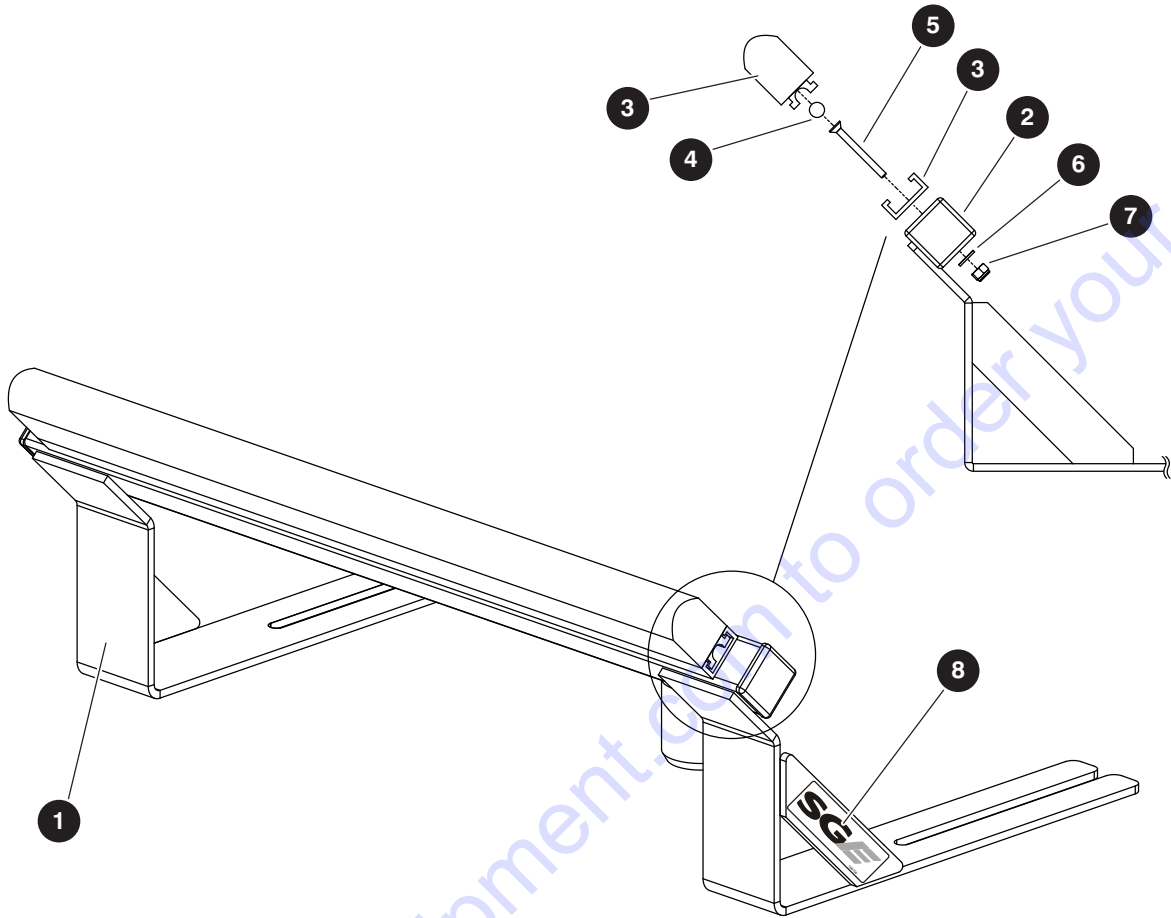

M198348AA

Index No.	Skyjack Part No.	Qty.	Description
-	198348	1	SGE
1	166101	1	• SUPPORT, Sensing edge
2	100702	2	• PLUG, Tube (1.25" x 1.25")
3	166107	1	• SENSING EDGE
4	166104	1	• ROD, Sensing edge lock
5	166105	3	• SCREW, Flat head cap (10-32 x 1.75" gr 5)
6	104694	3	• WASHER, Flat (#10)
7	300450	3	• NUT, Lock (10-32 gr 5 nylon)
8	166756	2	• LABEL, SGE
9	167218	1	• SCREW, Slotted binding head (6-32 x 0.25") (not shown)

## 1.13 Footswitch

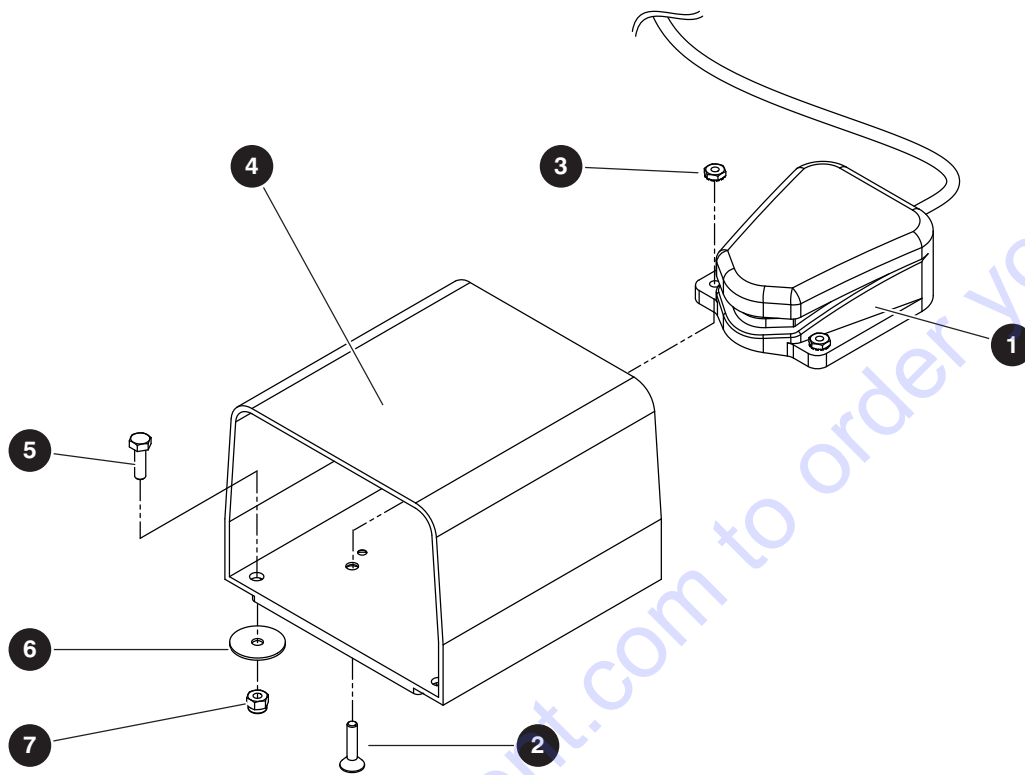

M154127AC

Index No.	Skyjack Part No.	Qty.	Description
-	154127	1	FOOTSWITCH ASSEMBLY
1	700187	1	• FOOTSWITCH
2	139688	2	• SCREW, Flat head machine (1/4"-20 x 1.00")
3	130017	2	• NUT, K-lock (#10-32, zinc)
4	700188	1	• COVER, Footswitch
5	103891	4	BOLT, Hex head (1/4"-20 x 0.87", Grade 5)
6	700598	4	WASHER, Fender
7	115649	4	NUT, Hex lock (1/4"-20 Grade 5, nylon)

# 1.14 Power to Platform - CE & AS

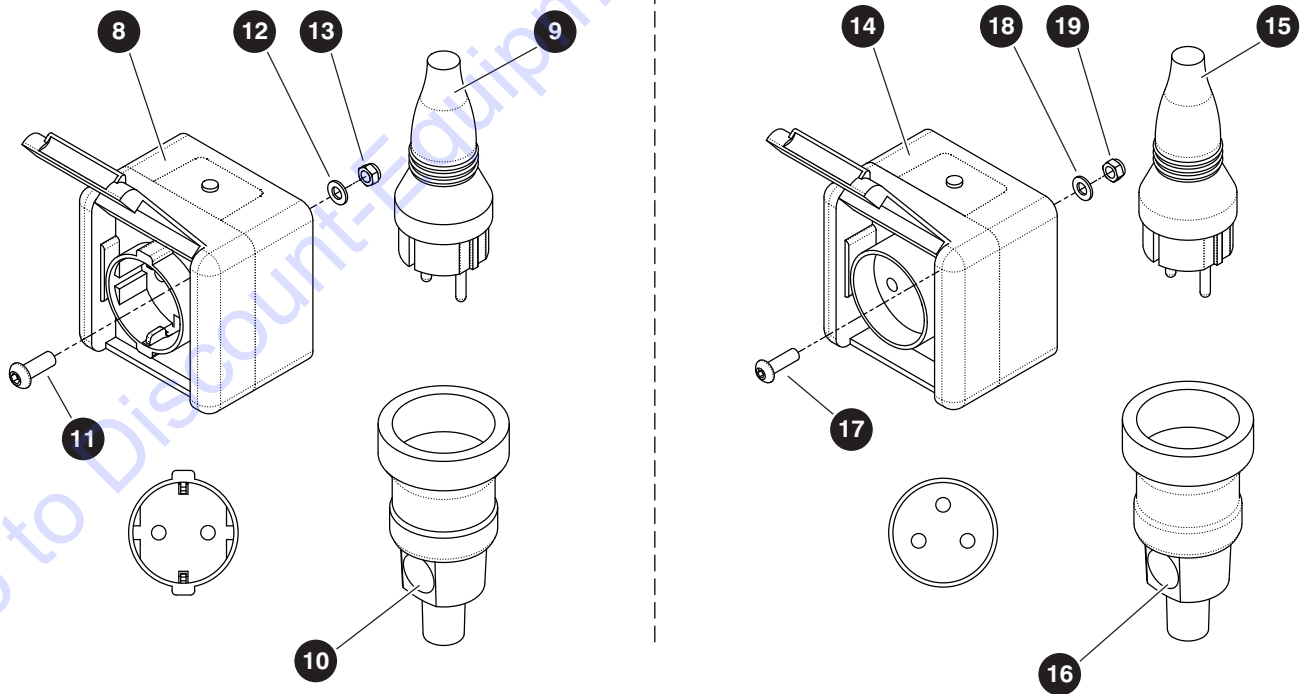
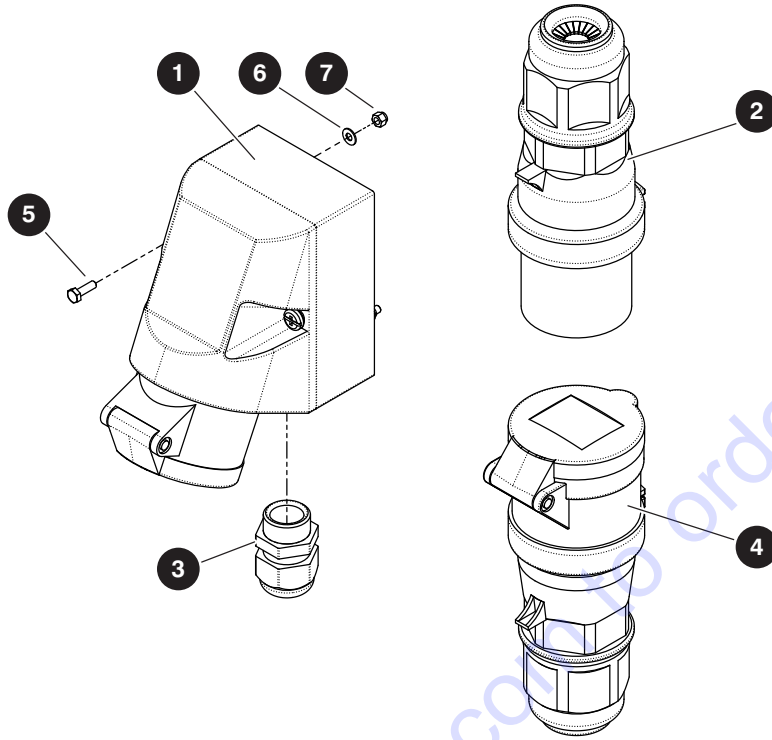

M226505AA\_M226509AA\_M226513AA

238271AAA

SJ45 AJ+

## 1.14 Power to Platform - CE & AS

Index No.	Skyjack Part No.	Qty.	Description
<b>A</b>	226505	1	POWER TO PLATFORM OUTLET - <b>UK with generator</b>
<b>B</b>	226507	1	POWER TO PLATFORM OUTLET - <b>UK no generator</b>
1	226503	1	• RECEPTACLE, 16 amp 110 VAC 2P+E
2	226501	1	• PLUG, 16 amp 110 VAC 2P+E
3	138373	1	• STRAIN RELIEF, M20
4	226502	1	• RECEPTACLE, 16 amp 110 VAC 2P+E, <b>A</b>
5	228463	2	• BOLT, Hex head (M3 x 0.5 x 10, cl 8.8)
6	600579	2	• WASHER, Flat (M4)
7	217626	2	• NUT, Hex head nylon lock (M3 x 0.5, cl 8)
<b>C</b>	226509	1	POWER TO PLATFORM OUTLET - <b>Type F with generator</b>
<b>D</b>	226511	1	POWER TO PLATFORM OUTLET - <b>Type F no generator</b>
8	226454	1	• OUTLET, Socket - 16 amp 250 V
9	157192	1	• PLUG, 250 V
10	226504	1	• RECEPTACLE, 250 V 16 amp, <b>C</b>
11	228459	2	• BOLT, Hex head (M5 x 0.8 x 16, cl 10.9)
12	933816	2	• WASHER, Flat (M5)
13	217628	2	• NUT, Hex head nylon lock (M5 x 0.8, cl 8)
<b>E</b>	226513	1	POWER TO PLATFORM OUTLET - <b>Type E with generator</b>
<b>F</b>	226515	1	POWER TO PLATFORM OUTLET - <b>Type E no generator</b>
14	226455	1	• OUTLET, Socket - 16 amp 250 V
15	157192	1	• PLUG, 250 V
16	226504	1	• RECEPTACLE, 250 V 16 amp, <b>E</b>
17	228459	2	• BOLT, Hex head (M5 x 0.8 x 16, cl 10.9)
18	933816	2	• WASHER, Flat (M5)
19	217628	2	• NUT, Hex head nylon lock (M5 x 0.8, cl 8)
-	103259	734"	CABLE, 220V (not shown)

## 1.15 Power to Platform - ANSI/CSA

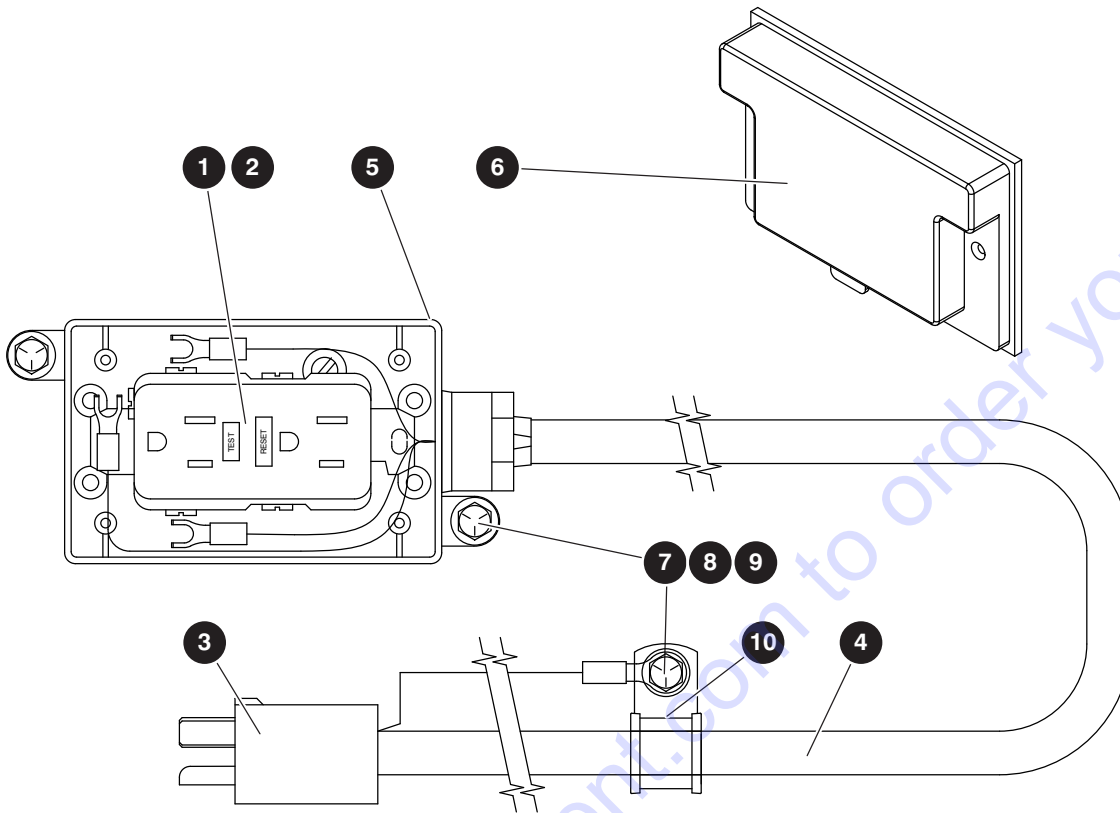

M1448634AA

Index No.	Skyjack Part No.	Qty.	Description
-	148634	1	110V OUTLET ASSEMBLY
1	109698	1	• RECEPTACLE, GFI
2	121461	2	• BOLT, Machine round head (6-32 UNC x 3/8")
-	149492	1	• 110V CABLE ASSEMBLY
3	104208	1	• • PLUG, Male (15A - 225V)
4	103259	758"	• • CABTIRE (12/3 300V)
4	136328	1	• BOX, AC outlet
5	109699	1	• PLATE, Weatherproof cover
6	115649	3	• NUT, Hex nylon lock (1/4"-20, Grade 5)
7	103857	3	• BOLT, Hex head (1/4"-20 x 1", Grade 5)
8	103995	3	• WASHER, Flat (1/4")
9	103024	1	• CLIP, Single (G8)

# Section 2 – Boom

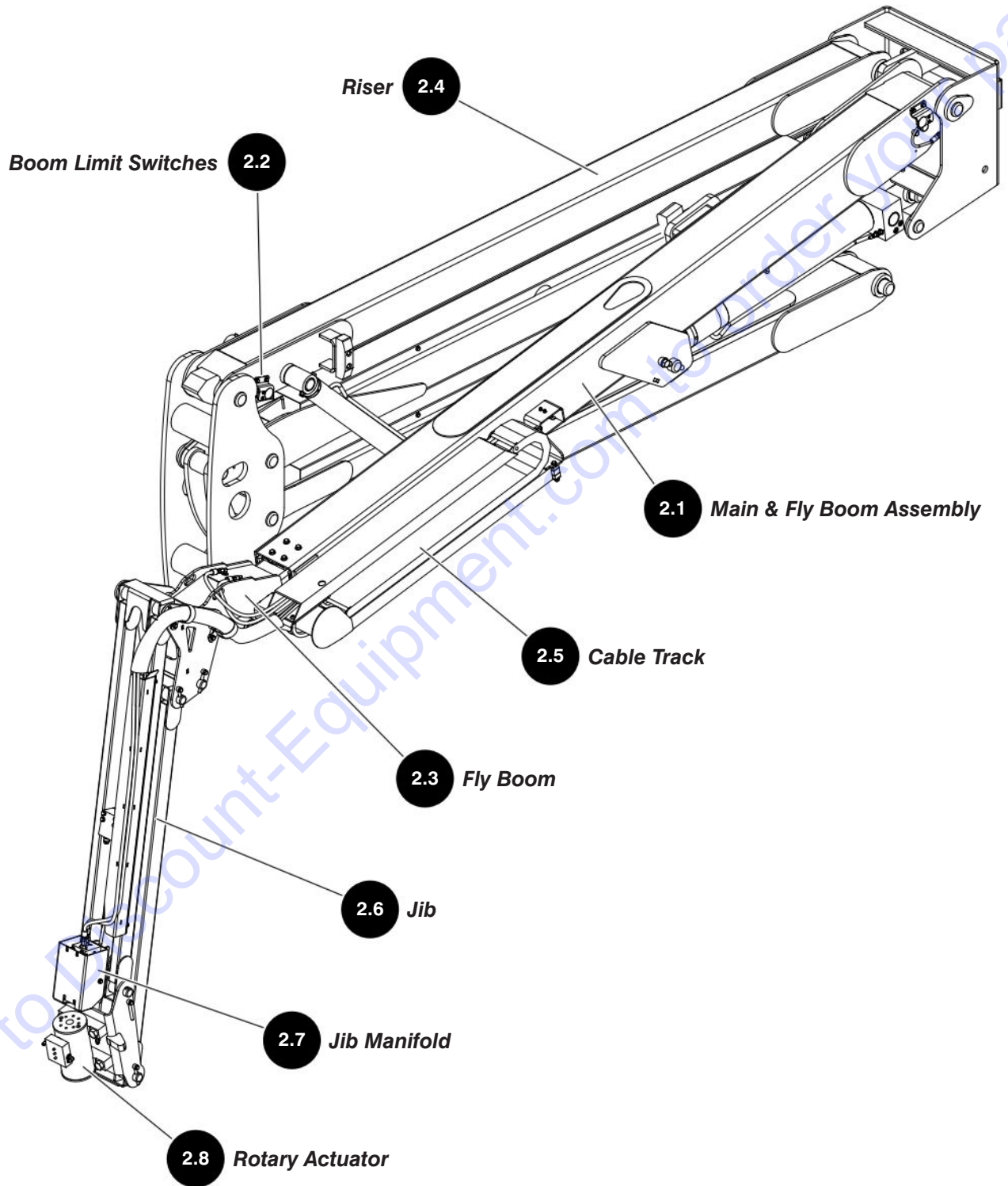

## 2.1 Main & Fly Boom Assembly

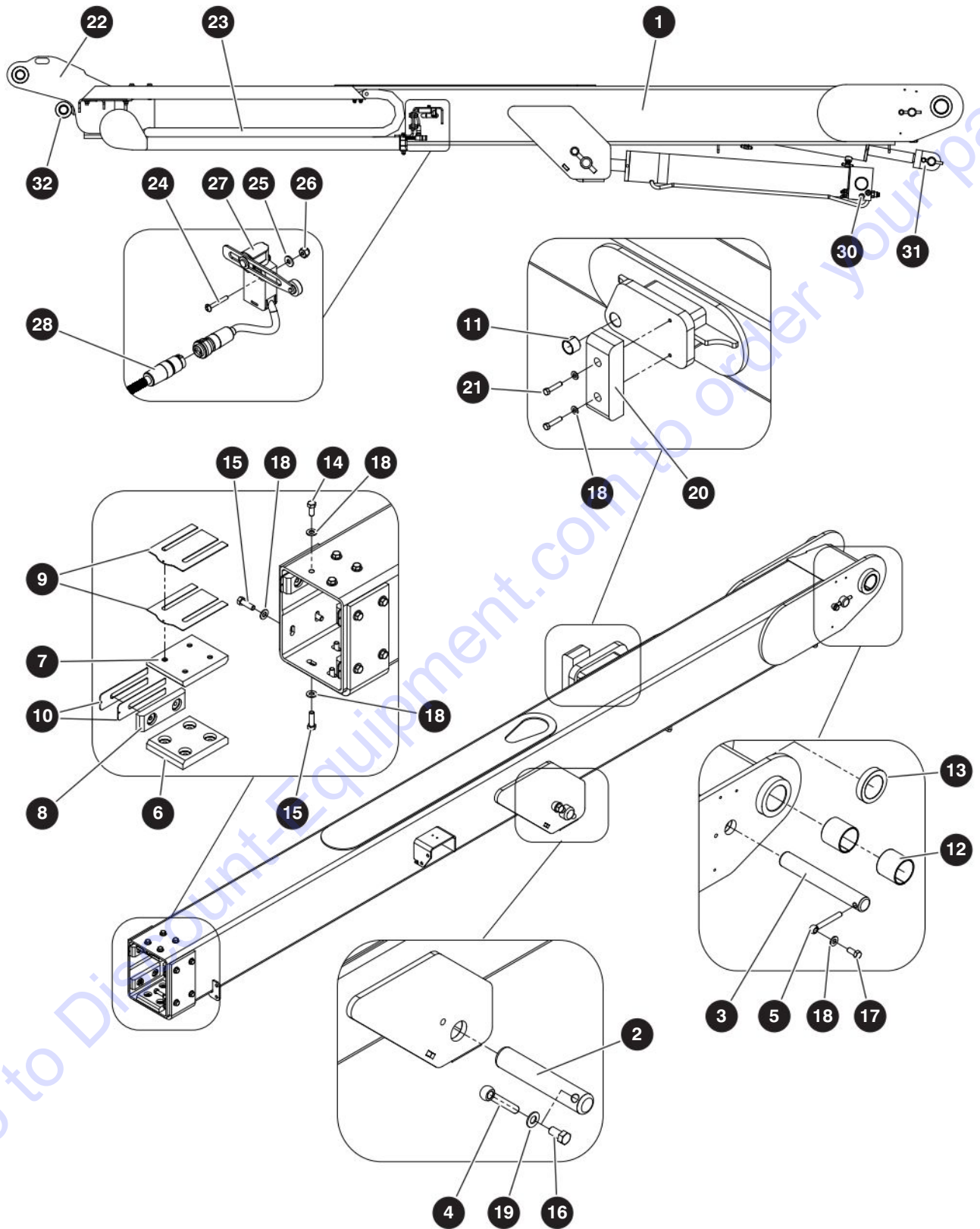

M162409AA

238271AAA

38

SJ45 AJ+

SKYJACK

## 2.1 Main & Fly Boom Assembly

Index No.	Skyjack Part No.	Qty.	Description
-	218930	1	MAIN AND FLY BOOM ASSEMBLY
	161977	1	• MAIN BOOM ASSEMBLY
1	161981	1	• • MAIN BOOM WELDMENT
2	148843	1	• • PIN (1 3/4" diameter x 9 1/2")
3	148844	1	• • PIN (1.25" diameter x 9")
4	146898	1	• • KEEPER PIN (5/8")
5	146897	1	• • KEEPER PIN (3/8")
6	148826	1	• • PAD, Bottom
7	148827	1	• • PAD, Top
8	148828	4	• • PAD, Side
9	148829	AR	• • SHIM, 16 Gauge (top)
	148830	AR	• • SHIM, 20 Gauge (top)
10	148837	AR	• • SHIM, 16 Gauge (side)
	148838	AR	• • SHIM, 20 Gauge (side)
11	148817	2	• • BUSHING (2" ID x 2")
12	148847	1	• • BUSHING (1 1/4" ID x 1")
13	149267	2	• • SPACER (Extension cylinder)
14	300437	4	• • BOLT, Hex head (3/8"-16 x 7/8" Grade 5)
15	101297	12	• • BOLT, Hex head (3/8"-16 x 1 1/4" Grade 5)
16	149015	1	• • BOLT, Hex head/patch (5/8"-16 x 7/8" Grade 8, ZP)
17	139193	1	• • BOLT, Hex head patch (3/8"-16 x 7/8" Grade 8, ZP)
18	125959	19	• • WASHER, Flat (3/8")
19	700782	1	• • WASHER, Flat (5/8")
20	152306	1	• • PAD, Wear - boom
21	103871	2	• • BOLT, Hex head (3/8"-16 x 1.75" Grade 5)
22	(Ref.)	1	• FLY BOOM ASSEMBLY (For components, refer to 2.3 Fly Boom)
23	(Ref.)	1	• E-CHAIN ASSEMBLY (For components, refer to 2.5 Cable Track)
-	161980	1	• BOOM EXTEND LIMIT SWITCH ASSEMBLY
24	112248	2	• • SCREW, Round head machine (#8-32 x 1")
25	103991	2	• • WASHER, Flat (#8)
26	138765	2	• • NUT, Hex lock (#8-32 Grade 5, nylon)
27	207016	1	• • SWITCH, Limit (with adjustable lever arm)
	207849	1	• • • BODY, Limit switch
	160009	1	• • • HEAD, Limit switch
	160011	1	• • • LEVER, Limit switch
28	207853	1	• • • CORD, Limit Switch (17 m)
29	(Ref.)	1	• EXTENSION CYLINDER (For components, refer to 3.1 Extension Cylinder)
30	(Ref.)	1	• MAIN BOOM LIFT CYLINDER (For components, refer to 3.2 Lift Cylinder)



## 2.1 Main & Fly Boom Assembly

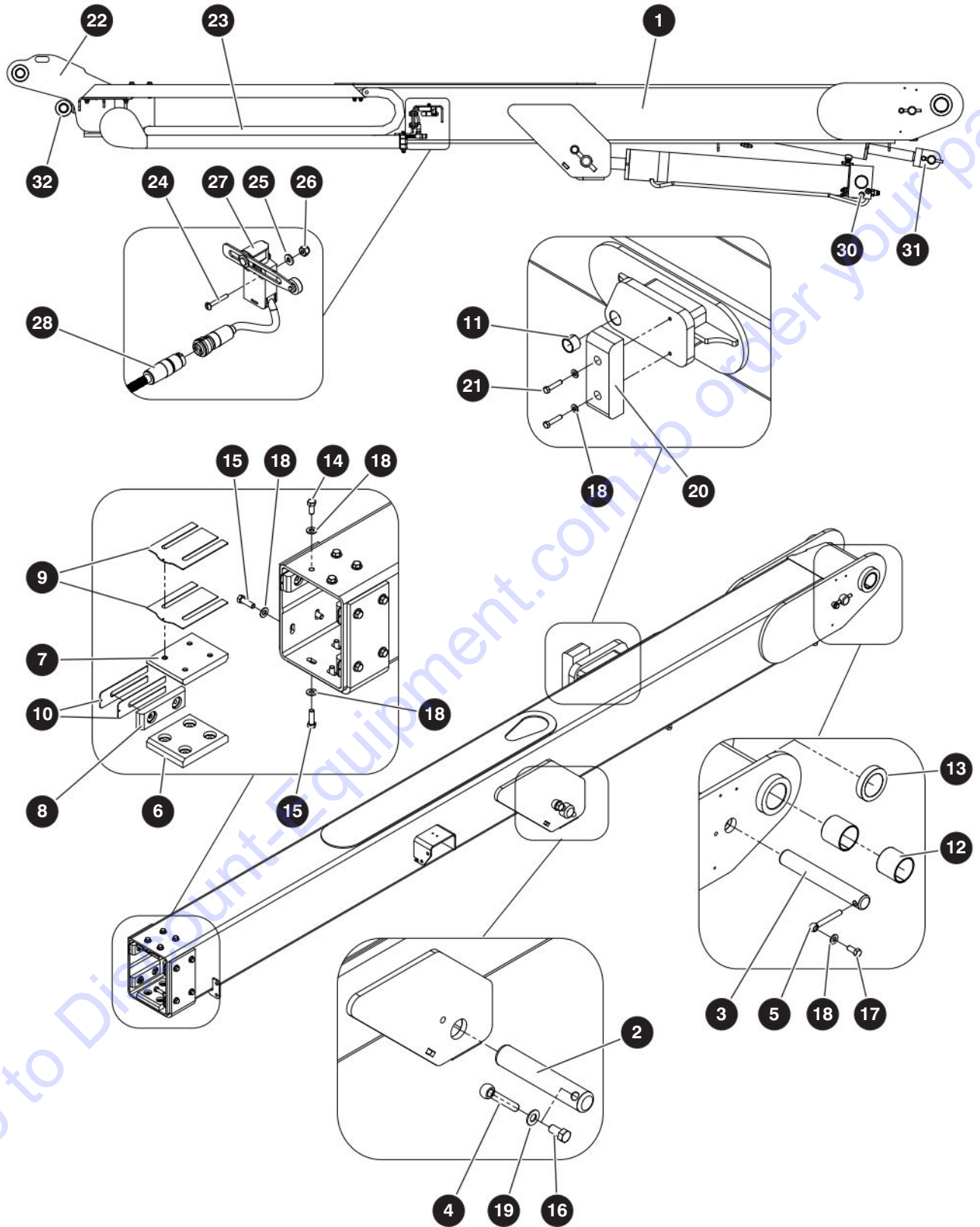

M162409AA

238271AAA

40

SJ45 AJ+

SKYJACK

## 2.1 Main & Fly Boom Assembly

Index No.	Skyjack Part No.	Qty.	Description
31	(Ref.)	1	<ul style="list-style-type: none"> <li>• MASTER CYLINDER (For components, refer to 3.5 Master Cylinder)</li> </ul>
32	(Ref.)	1	<ul style="list-style-type: none"> <li>• SLAVE CYLINDER (For components, refer to 3.6 Slave Cylinder)</li> </ul>
33	(Ref.)	1	<ul style="list-style-type: none"> <li>• E-CHAIN HOSE KIT (Not Shown) (For components, refer to 8.2 Boom Hoses)</li> </ul>

## 2.2 Boom Limit Switches

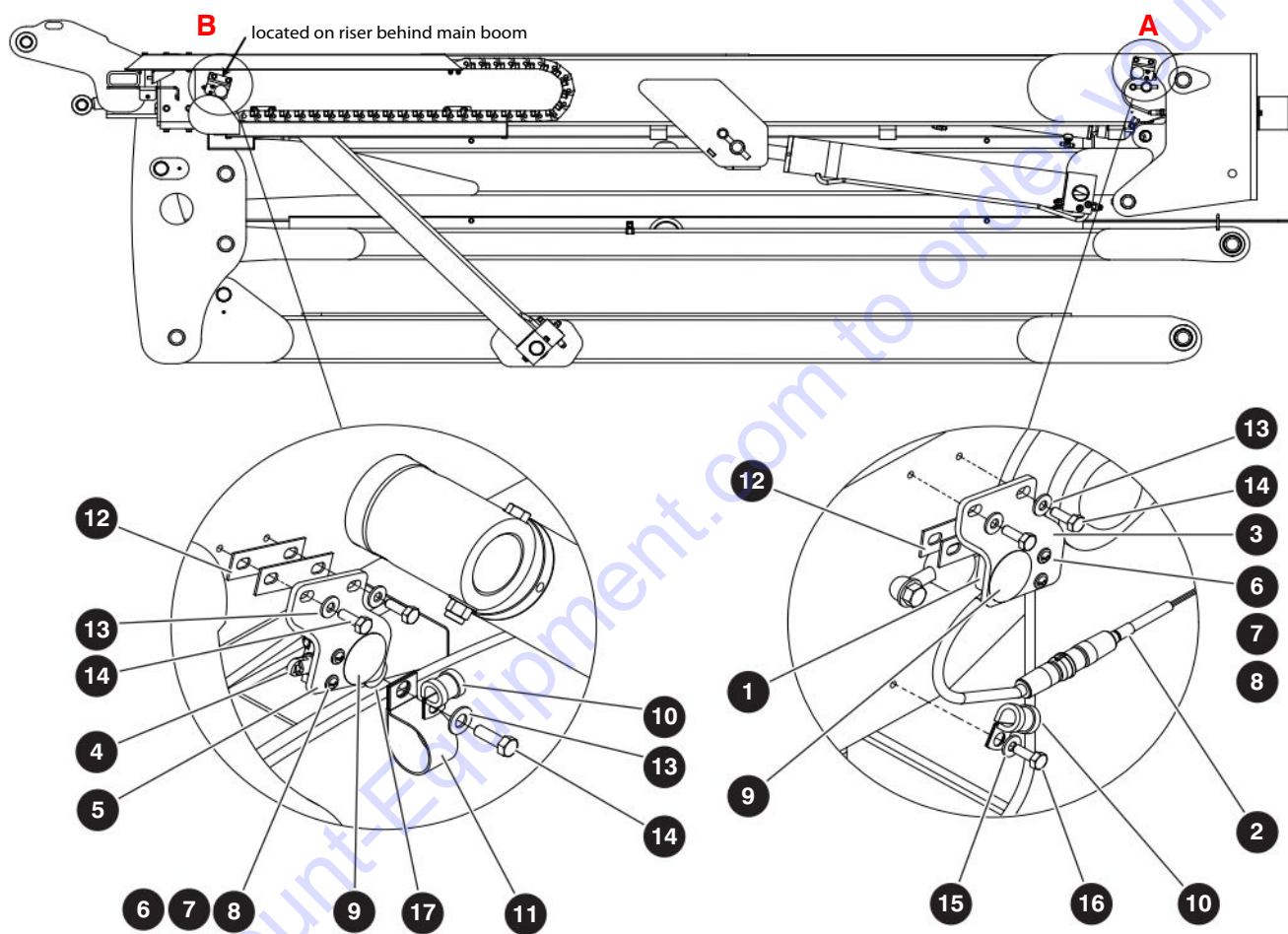

M162345AB

238271AAA

SJ45 AJ+

## 2.2 Boom Limit Switches

Index No.	Skyjack Part No.	Qty.	Description
-	162345	1	LIMIT SWITCH ASSEMBLY - MAIN AND RISER BOOM
<b>A</b>	162362	1	• BRACKET ASSEMBLY, Limit Switch
1	207017	1	• • SWITCH ASSEMBLY, Roller plunger
2	207853	1	• • • CORD, Switch
	207849	1	• • • BODY, Limit switch
	207850		• • • HEAD, Limit switch
3	162363	1	• • BRACKET
<b>B</b>	162370	1	• BRACKET ASSEMBLY, Limit Switch
4	199546	1	• • SWITCH, Limit, roller plunger
	207850		• • • HEAD, Limit switch
5	162363	1	• • BRACKET
6	152294	2	• • SCREW, Round head machine (#8-32 x 1.25"), <b>A, B</b>
7	138765	2	• • NUT, Hex head nylon lock (#8-32, Grade 5), <b>A, B</b>
8	103991	4	• • WASHER, Flat (#8), <b>A, B</b>
9	156613	1	• • LABEL, Do not alter, <b>A, B</b>
10	149495	2	• CLAMP, Tube (cushioned)
11	409187	1	• CLAMP, Hose (1-1/2")
12	161053	4	• SHIM
13	103995	5	• WASHER, Flat (1/4")
14	103856	5	• BOLT, Hex head (1/4"-20 x 0.75", Grade 5)
15	103472	2	• WASHER, Flat (3/8")
16	103864	1	• BOLT, Hex head (5/16"-18 x 1.00", Grade 5)
17	103984	1	• NUT, Hex head nylon lock (5/16"-18, Grade 5)

## 2.3 Fly Boom

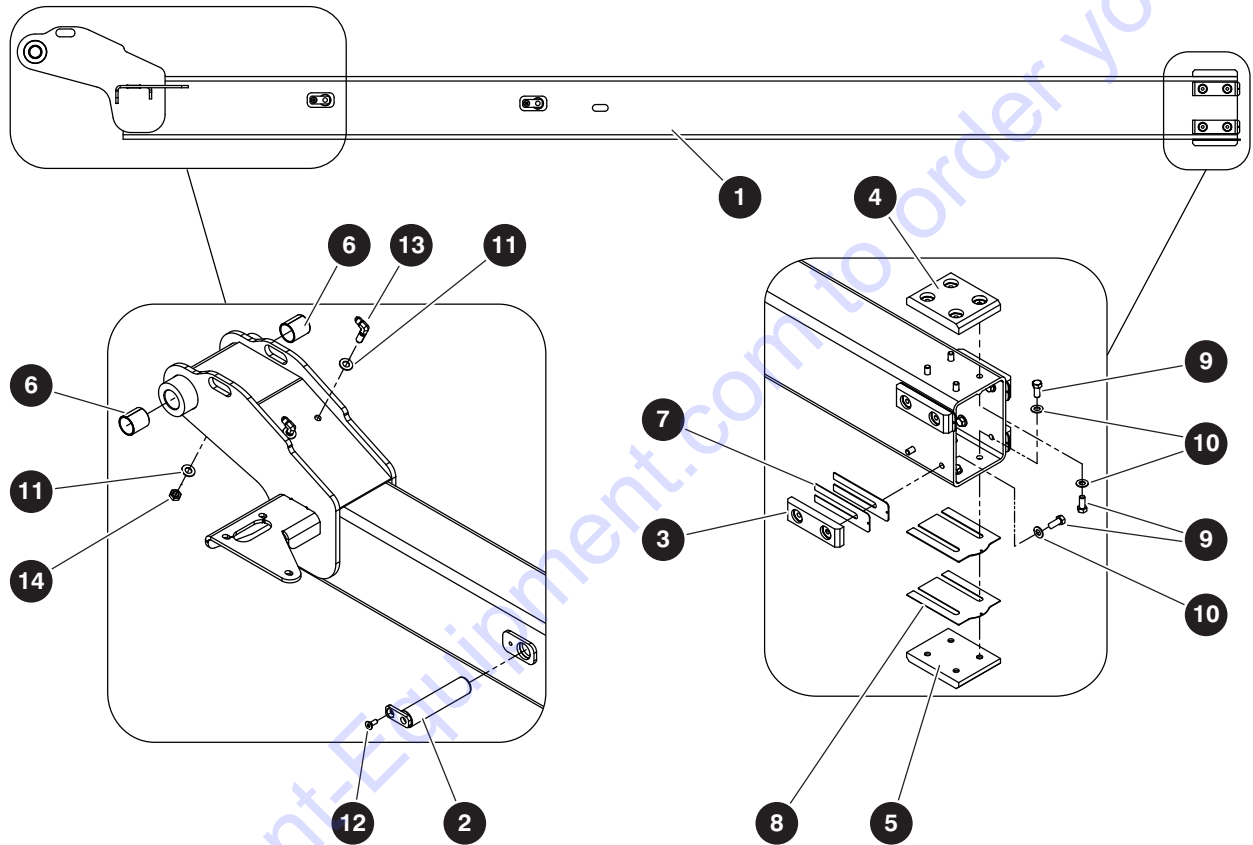

M161978AB

238271AAA

SJ45 AJ+

## 2.3 Fly Boom

Index No.	Skyjack Part No.	Qty.	Description
-	218069	1	FLY BOOM
1	161986	1	• FLY BOOM WELDMENT
2	148839	2	• PIN WELDMENT (1 1/4" diameter x 5 11/16")
3	148828	4	• PAD, Side
4	148826	1	• PAD, Top
5	148827	1	• PAD, Bottom
6	125262	2	• BUSHING, CJS 2024 (1.25" ID x 1.50" lg)
7	148837	AR	• SHIM, 16 Gauge (side)
	148838	AR	• SHIM, 20 Gauge (side)
8	148829	AR	• SHIM, 16 Gauge (bottom)
	148830	AR	• SHIM, 20 Gauge (bottom)
9	300437	16	• BOLT, Hex head (3/8"-16 x 7/8" Grade 5)
10	103472	24	• WASHER, Flat (3/8")
11	119313	4	• WASHER, Flat (7/16")
12	704642	2	• SCREW, Flat head cap (5/16"-18 x 3/4" Grade 5)
13	149418	2	• FITTING, Elbow 90° bulkhead (04 JICM - 04 JICM)
14	143963	2	• FITTING, Nut bulkhead (04 JIC)

## 2.4 Riser

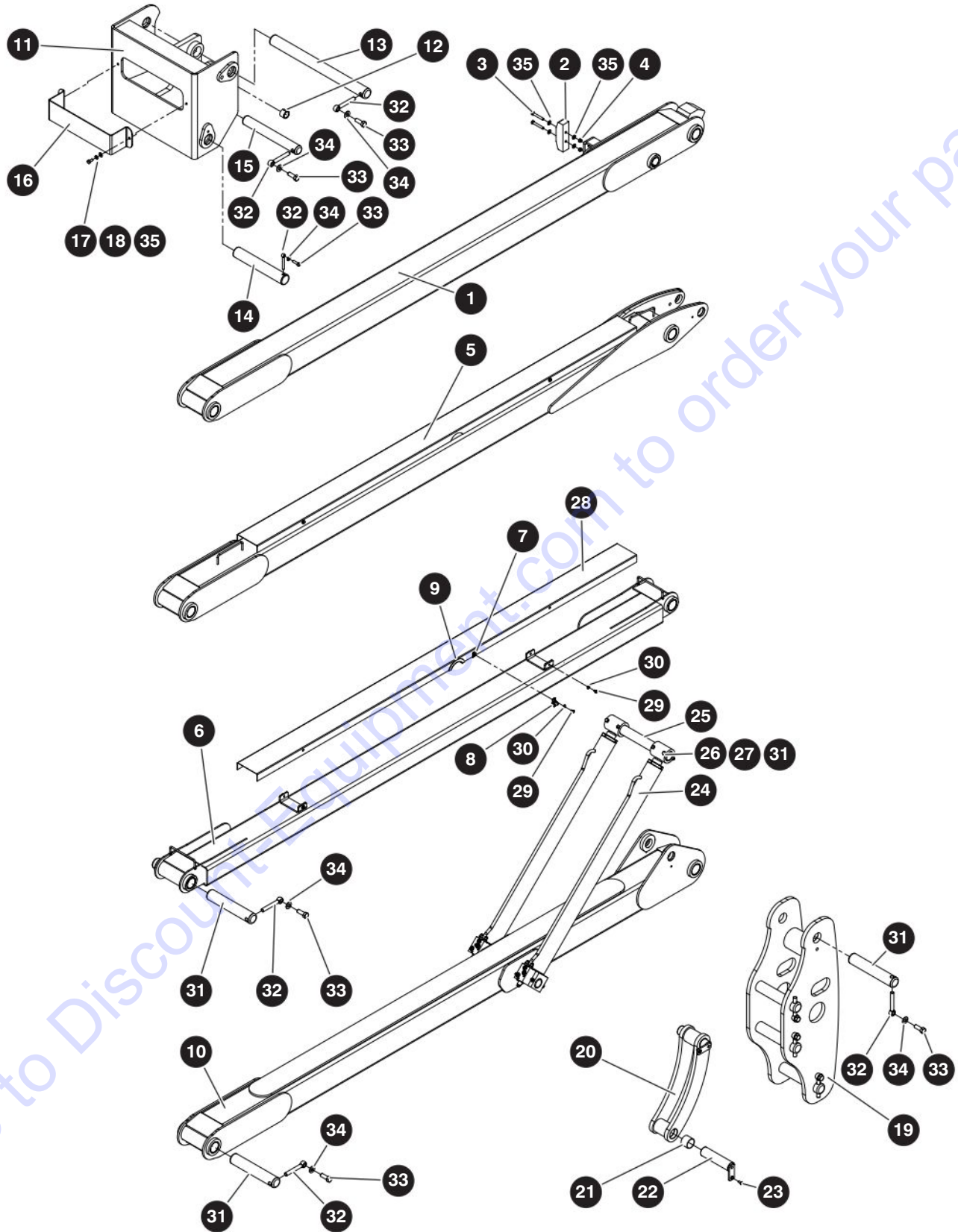

M162334AA

238271AAA

## 2.4 Riser

Index No.	Skyjack Part No.	Qty.	Description
-	231357	1	RISER BOOM ASSEMBLY
-	162337	1	• UPPER RISER BOOM
1	162338	1	• • WELDMENT, Upper riser boom
	148861	2	• • BUSHING (1 3/4" ID x 2")
	148817	4	• • BUSHING (2" ID x 2")
2	152525	1	• • PAD, Bumper
3	103873	2	• • BOLT, Hex head (3/8"-16 x 2 1/2" Grade 5)
4	144238	2	• • NUT, Torque lock (3/8"-16, Grade C)
5	148786	1	• THIRD RISER BOOM
	148787	1	• • WELDMENT, Third riser boom
	148817	4	• • BUSHING (2" ID x 2")
-	218062	1	• SECOND RISER BOOM
6	148781	1	• • WELDMENT, Second riser boom
	148817	4	• • BUSHING (2" ID x 2")
7	152516	2	• • NUT RETAINER, J-Type (1/4"-20)
8	144129	2	• • CLIP, Single
9	117398	7.4"	• • TRIM, Protective
10	158763	1	• LOWER RISER BOOM
	158764	1	• • WELDMENT, Lower riser boom
	148861	2	• • BUSHING (1 3/4" ID x 2")
	148817	4	• • BUSHING (2" ID x 2")
-	162339	1	• UPPER PIVOT WELDMENT
11	169109	1	• • WELDMENT, Upper pivot
12	148847	1	• • BUSHING (1 1/4" ID x 1")
13	148823	1	• • PIN (2" diameter x 24.188")
14	169110	1	• • PIN (2" diameter x 12.375")
15	148824	1	• • PIN (2" diameter x 13.75")
16	148906	1	• • PLATE, Guard
17	101632	2	• • BOLT, Hex head (3/8"-16 x 3/4" Grade 5)
18	103999	2	• • WASHER, Lock (3/8")
-	162335	1	• LOWER PIVOT
19	162336	1	• • WELDMENT, Lower pivot
-	148813	1	• RISER LINK WELDMENT
20	148814	1	• • WELDMENT, Riser link
21	101564	6	• • BUSHING (1-3/4" ID x 1")
22	152319	2	• • PIN (1.75" diameter x 7")
23	704642	2	• • SCREW, Flat head cap (5/16"-18 x 3/4" Grade 5)
-	158769	1	• RISER LIFT CYLINDER ASSEMBLY
24	(Ref.)	2	• • CYLINDER, Riser lift (For components, refer to 3.4 Riser Cylinder)
25	158770	2	• • PIN (1.75" diameter x 15.00")
26	103916	2	• • BOLT, Hex head (3/8"-16 x 3.25", Grade 5)
27	104606	4	• • NUT, Hex head nylon lock (3/8"-16, Grade 5)
28	148855	2	• COVER, Riser
29	112495	10	• BOLT, Hex head (1/4"-20 x 3/8" Grade 5)
30	103995	10	• WASHER, Flat hardened (1/4")



## 2.4 Riser

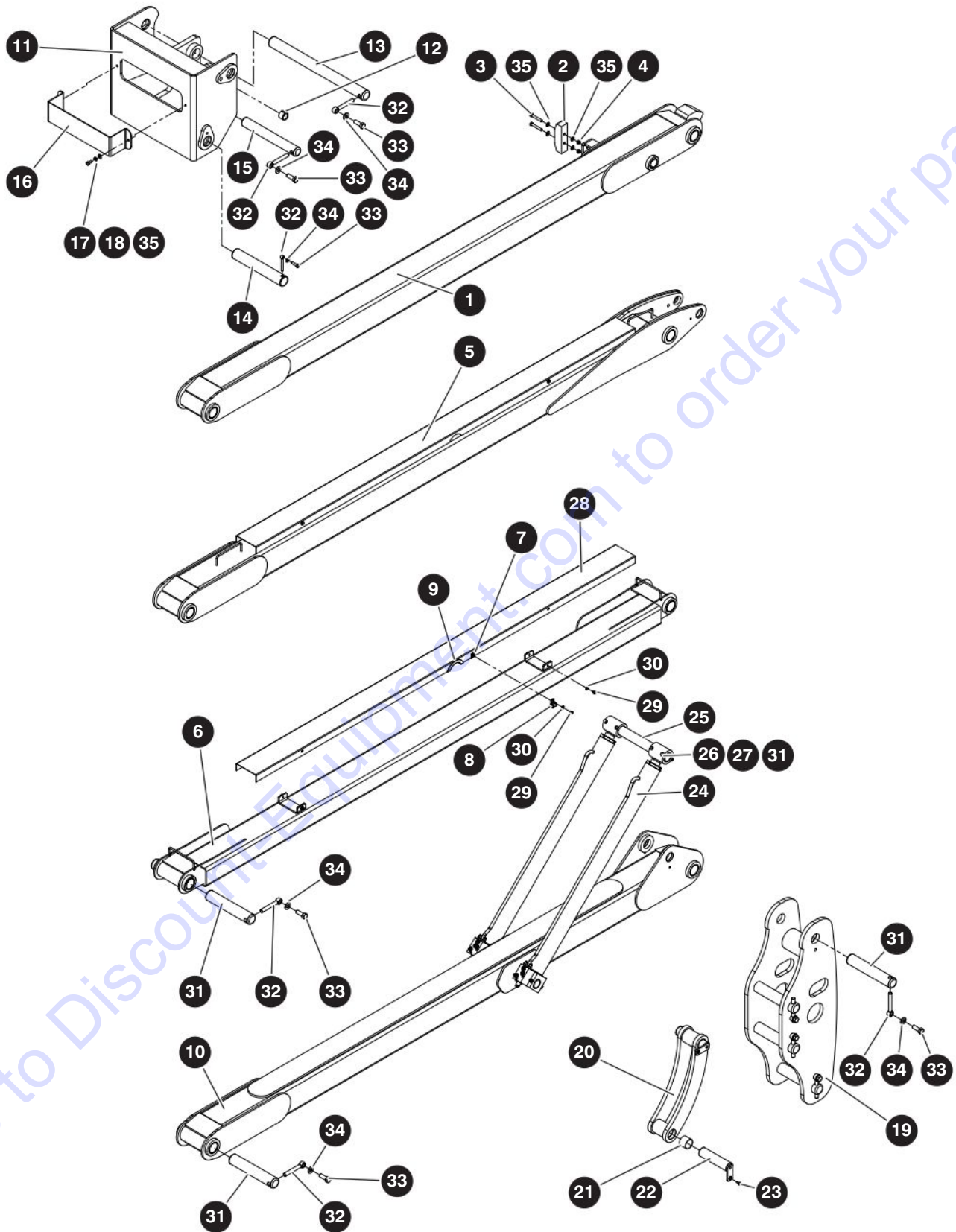

M162334AA

238271AAA

## 2.4 Riser

Index No.	Skyjack Part No.	Qty.	Description
31	148819	6	• PIN (2" diameter x 11.063")
32	146898	9	• KEEPER PIN (5/8")
33	148944	9	• BOLT, Hex head patch (5/8"-11 x 1 3/4" Grade 8)
34	700782	9	• WASHER, Flat hardened (5/8")
35	103472	6	• WASHER, Flat (3/8")

# PARTS FINDER

**Search Website  
by Part Number**



**Search Manual  
Library For Parts  
Manual & Lookup Part  
Numbers – Purchase  
or Request Quote**

**Search Manuals**

Enter your information to help us find the right parts manual for your machine.

\* Brand:

\* Model:

\* Serial:

\* Part Number:

SEARCH

**Can't Find Part or  
Manual? Request Help  
by Manufacturer,  
Model & Description**

**Parts Order Form**

Please fill in the following information to help us find the right part for your machine.

MANUFACTURER:

MODEL:

DESCRIPTION:

DATE:

TIME:

PHONE:

EMAIL:

ADDRESS:

CITY:

STATE:

ZIP:

COUNTRY:

SEARCH

Discount-Equipment.com is your online resource for quality parts & equipment.

Florida: **561-964-4949** Outside Florida TOLL FREE: **877-690-3101**

**Need parts?**

Click on this link: <http://www.discount-equipment.com/category/5443-parts/> and choose one of the options to help get the right parts and equipment you are looking for. Please have the machine model and serial number available in order to help us get you the correct parts. If you don't find the part on the website or on one of the online manuals, please fill out the request form and one of our experienced staff members will get back to you with a quote for the right part that your machine needs.

We sell worldwide for the brands: Genie, Terex, JLG, MultiQuip, Mikasa, Essick, Whiteman, Mayco, Toro Stone, Diamond Products, Generac Magnum, Airman, Haulotte, Barreto, Power Blanket, Nifty Lift, Atlas Copco, Chicago Pneumatic, Allmand, Miller Curber, Skyjack, Lull, Skytrak, Tsurumi, Husquvarna Target, Stow, Wacker, Sakai, Mi-T-M, Sullair, Basic, Dynapac, MBW, Weber, Bartell, Bennar Newman, Haulotte, Ditch Runner, Menegotti, Morrison, Contec, Buddy, Crown, Edco, Wyco, Bomag, Laymor, EZ Trench, Bil-Jax, F.S. Curtis, Gehl Pavers, Heli, Honda, ICS/PowerGrit, IHI, Partner, Imer, Clipper, MMD, Koshin, Rice, CH&E, General Equipment, Amida, Coleman, NAC, Gradall, Square Shooter, Kent, Stanley, Tamco, Toku, Hatz, Kohler, Robin, Wisconsin, Northrock, Oztec, Toker TK, Rol-Air, APT, Wylie, Ingersoll Rand / Doosan, Innovatech, Con X, Ammann, Mecalac, Makinex, Smith Surface Prep, Small Line, Wanco, Yanmar

## 2.5 Cable Track

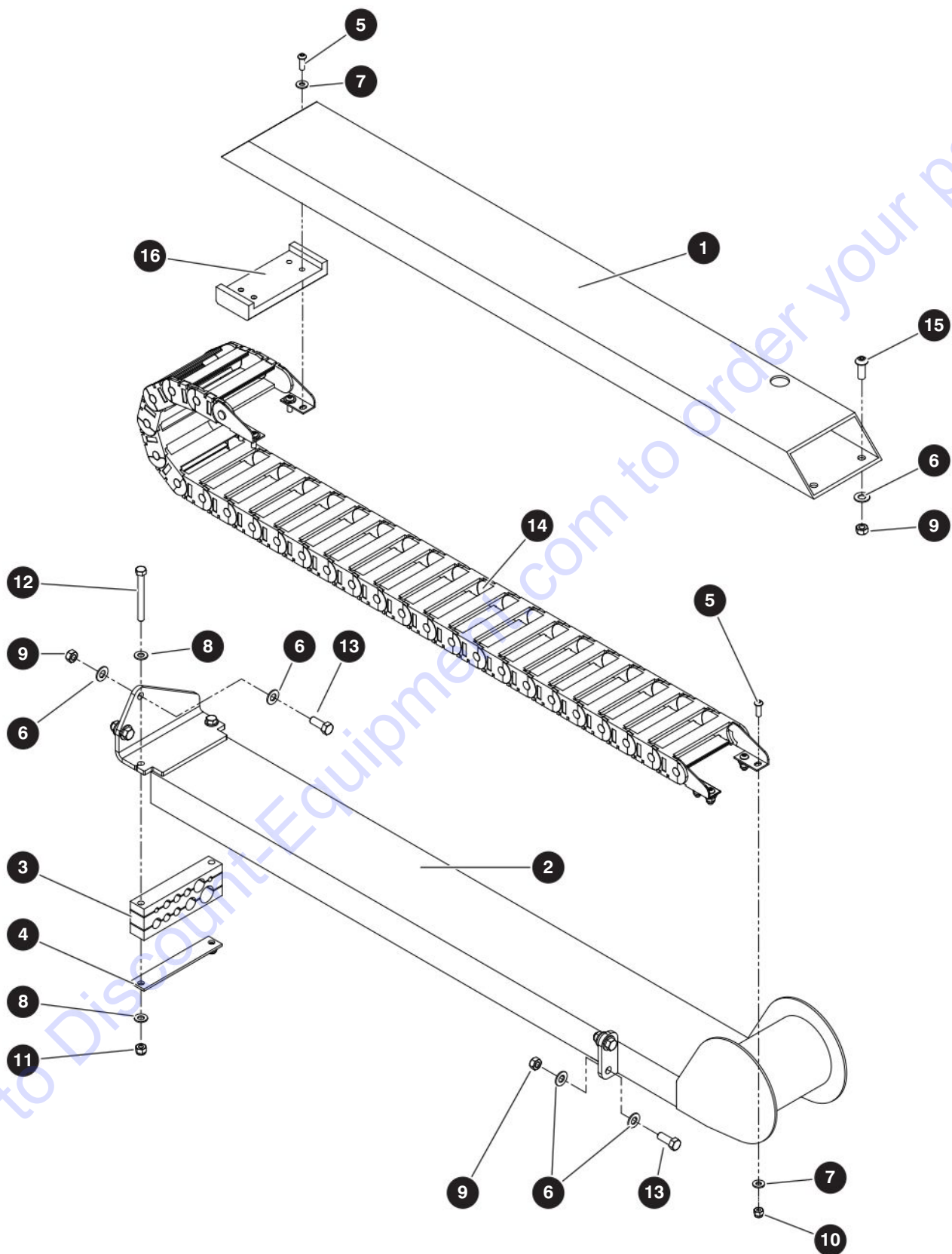

M161979AD

238271AAA

SJ45 AJ+

## 2.5 Cable Track

Index No.	Skyjack Part No.	Qty.	Description
-	231507	1	CABLE TRACK
1	161990	1	• TUBE, E-chain upper
2	161992	1	• TUBE, E-chain lower
3	231503	1	• CLAMP, Hose
4	710210	1	• PLATE, Hose guide
5	139168	8	• SCREW, Button head cap (1/4"-20 x 0.75")
6	103472	11	• WASHER, Flat (3/8")
7	103995	8	• WASHER, Flat (1/4")
8	103996	4	• WASHER, Flat (5/16")
9	144238	7	• NUT, Torque lock (3/8"-16 Grade C)
10	115649	4	• NUT, Hex head nylon lock (1/4"-20 Grade 5)
11	103984	2	• NUT, Hex head nylon lock (5/16"-18 Grade 5)
12	103867	2	• BOLT, Hex head (5/16"-18 x 3.00" Grade 5)
13	103473	4	• BOLT, Hex head (3/8"-16 x 1.00" Grade 5)
14	168334	1	• E-CHAIN, 250 series, 26 links, A
	210078	1	• • MOUNTING BRACKET SET
	210077	A/R	• • LINK, E-Chain
	210074	A/R	• • SEPARATOR, E-Chain
15	103949	3	• SCREW, Button head cap (3/8"-16 x 1.00")
16	196488	1	• PAD, Wear

## 2.6 Jib

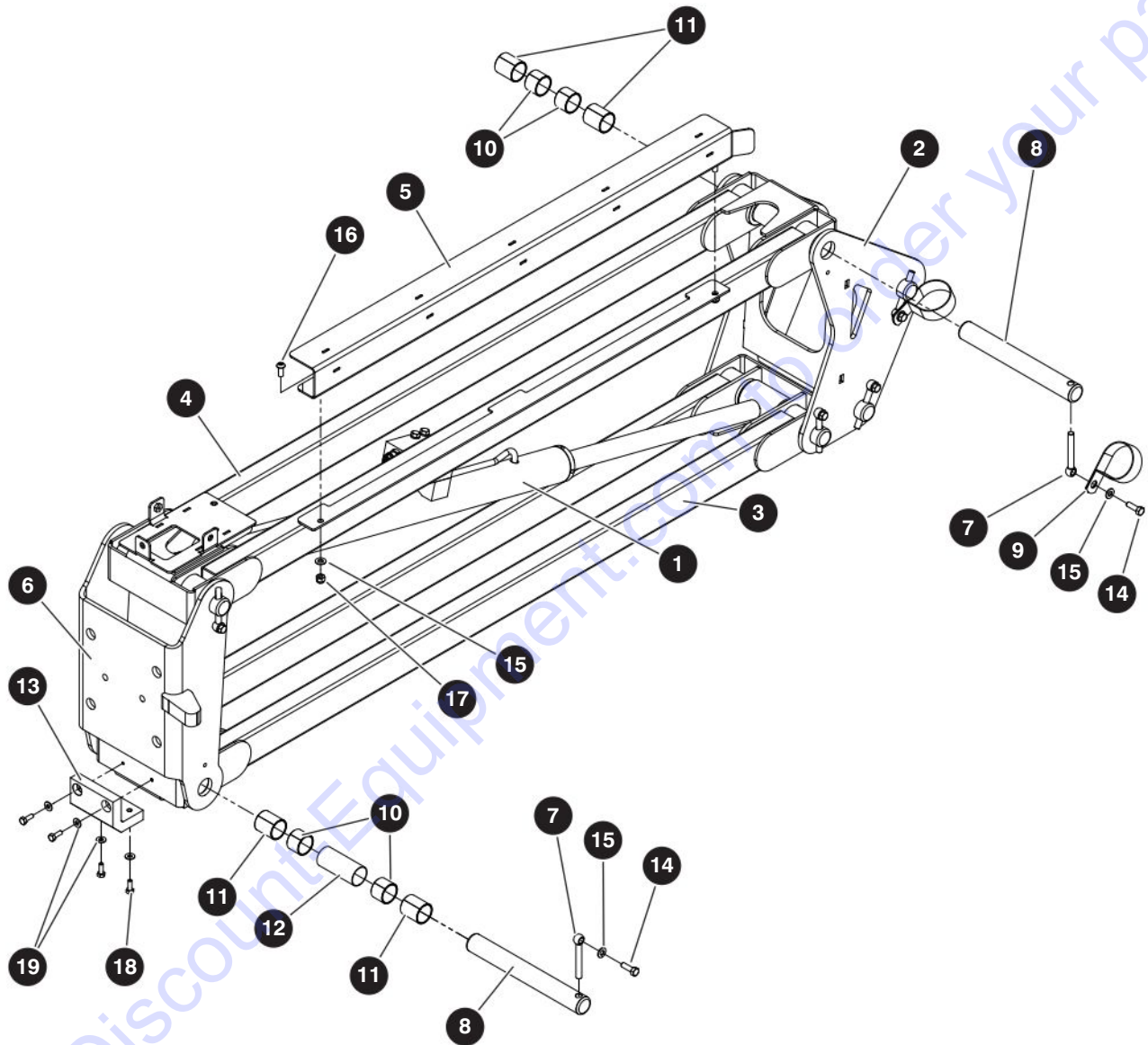

M167645AA

238271AAA

SJ45 AJ+

## 2.6 Jib

Index No.	Skyjack Part No.	Qty.	Description
-	218053	1	JIB BOOM
1	(Ref.)	1	<ul style="list-style-type: none"> <li>JIB CYLINDER (For components, refer to 3.7 Jib Cylinder)</li> </ul>
2	218054	1	<ul style="list-style-type: none"> <li>BRACKET, Jib mount</li> </ul>
3	218059	1	<ul style="list-style-type: none"> <li>WELDMENT, Lower arm</li> </ul>
4	218056	1	<ul style="list-style-type: none"> <li>WELDMENT, Upper arm</li> </ul>
5	148891	1	<ul style="list-style-type: none"> <li>COVER, Hose</li> </ul>
6	167659	1	<ul style="list-style-type: none"> <li>BRACKET, Platform mount</li> </ul>
7	146897	6	<ul style="list-style-type: none"> <li>KEEPER PIN (3/8")</li> </ul>
8	148890	6	<ul style="list-style-type: none"> <li>PIN (1 1/4" diameter x 10 3/16")</li> </ul>
9	143987	2	<ul style="list-style-type: none"> <li>CLAMP (2 1/2")</li> </ul>
10	148847	8	<ul style="list-style-type: none"> <li>BUSHING (1 1/4" ID x 1")</li> </ul>
11	125262	8	<ul style="list-style-type: none"> <li>BUSHING (1 1/4" ID x 1 1/2")</li> </ul>
12	148920	2	<ul style="list-style-type: none"> <li>SPACER</li> </ul>
13	148936	1	<ul style="list-style-type: none"> <li>PAD, Wear</li> </ul>
14	148943	6	<ul style="list-style-type: none"> <li>BOLT, Hex head patch (5/16"-18 x 1" Grade 8)</li> </ul>
15	103996	8	<ul style="list-style-type: none"> <li>WASHER, Flat (5/16")</li> </ul>
16	300064	2	<ul style="list-style-type: none"> <li>SCREW, Button head cap (5/16"-18 x 3/4")</li> </ul>
17	103984	2	<ul style="list-style-type: none"> <li>NUT, Hex lock (5/16"-18 Grade 5, nylon)</li> </ul>
18	103856	4	<ul style="list-style-type: none"> <li>BOLT, Hex head (1/4"-20 x 3/4" Grade 5)</li> </ul>
19	103995	4	<ul style="list-style-type: none"> <li>WASHER, Flat (1/4")</li> </ul>

## 2.7 Jib Manifold

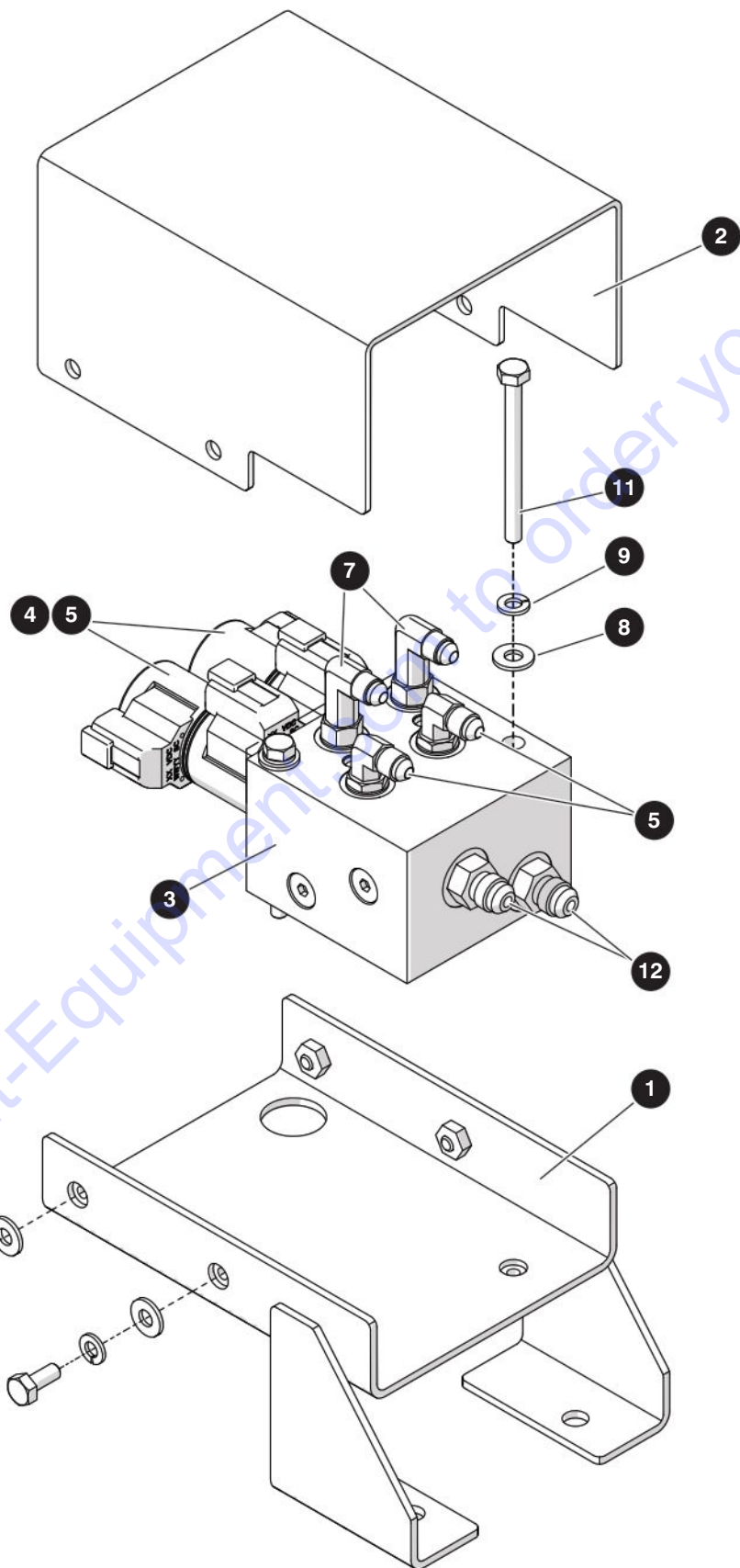

M167646AB

238271AAA



## 2.7 Jib Manifold

Index No.	Skyjack Part No.	Qty.	Description
-	231510	1	JIB MANIFOLD
1	231514	1	• SUPPORT, Manifold
2	231517	1	• COVER
3	231501	1	• MANIFOLD, Jib
4	166036	2	• • VALVE
5	208881	4	• • COIL
6	125883	2	• • FITTING, 90° (04JICM-04ORBM)
7	147552	2	• • FITTING, 90° long (04JICM004ORBM)
8	103995	6	• WASHER, Flat (1/4")
9	104000	6	• WASHER, Lock (1/4")
10	103892	4	• BOLT, Hex head (0.25"-20 x 0.625" Grade 5)
11	113583	2	• BOLT, Hex head (0.25"-20 x 3.00" Grade 5)
12	701956	2	• FITTING, Straight (04 JICM - 06 ORBM)

## 2.8 Rotary Actuator

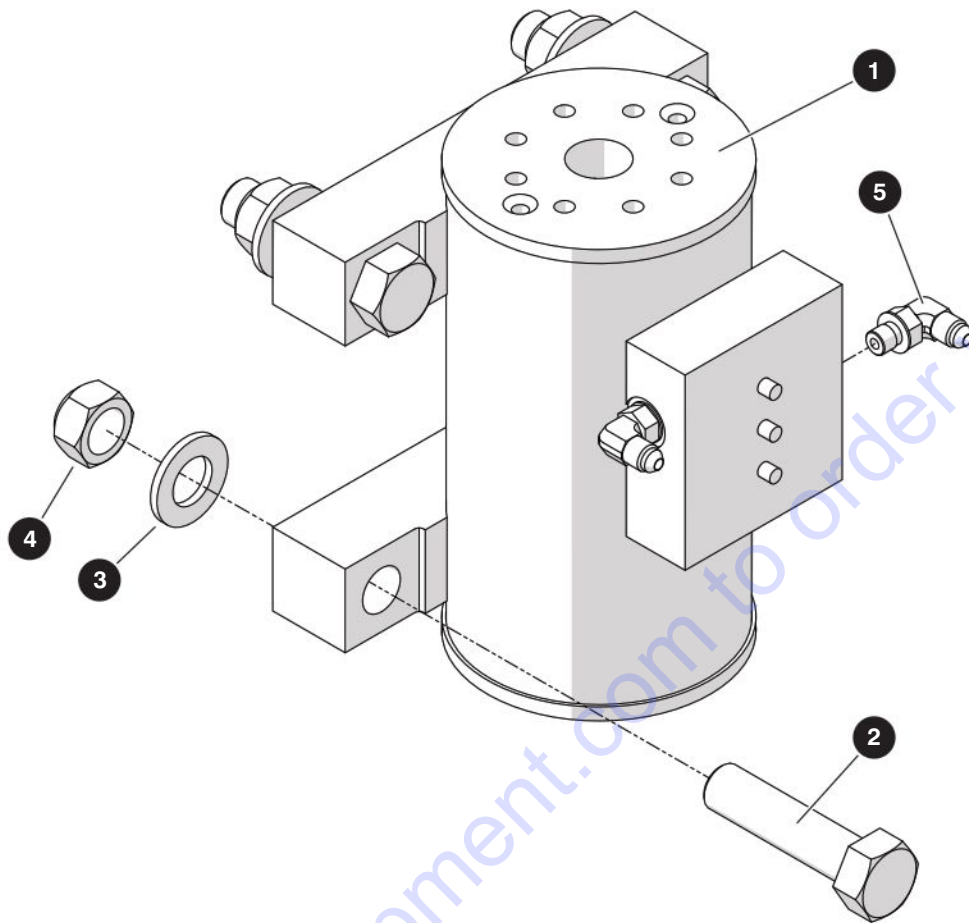

M1467687AA

Index No.	Skyjack Part No.	Qty.	Description
-	231518	1	ROTARY ACTUATOR
1	144710	1	• ACTUATOR, Rotary
2	103894	4	• BOLT, Hex head (3/4"-10 x 3" Grade 8)
3	702194	4	• WASHER, Flat (3/4")
4	700575	4	• NUT, Crownlock (3/4"-10 Grade 8)
5	125883	2	• FITTING, 90° (04 JICM - 04 ORBM)
<b>K</b>	144709	1	SEAL KIT

# Section 3 – Cylinders

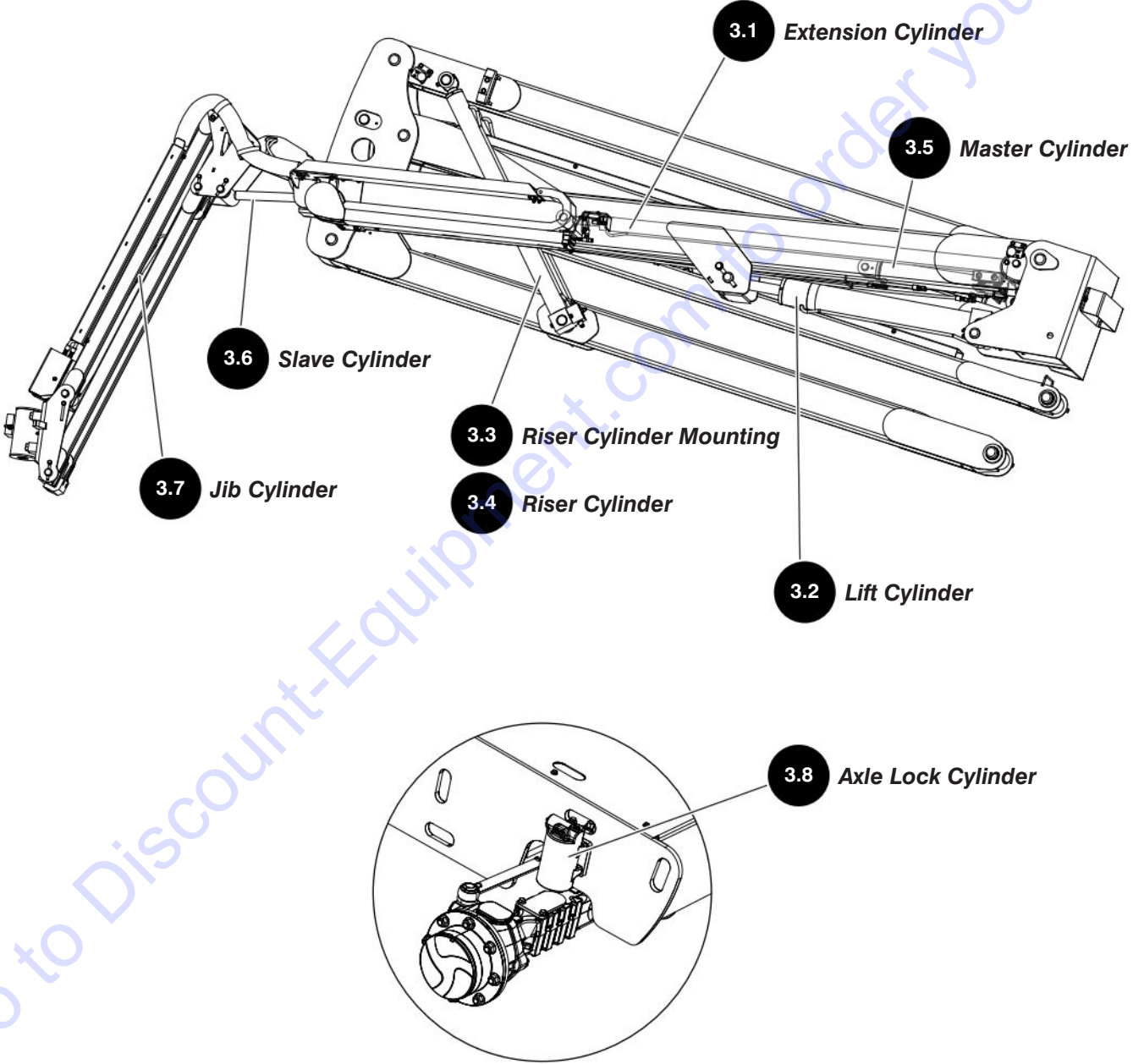

### 3.1 Extension Cylinder

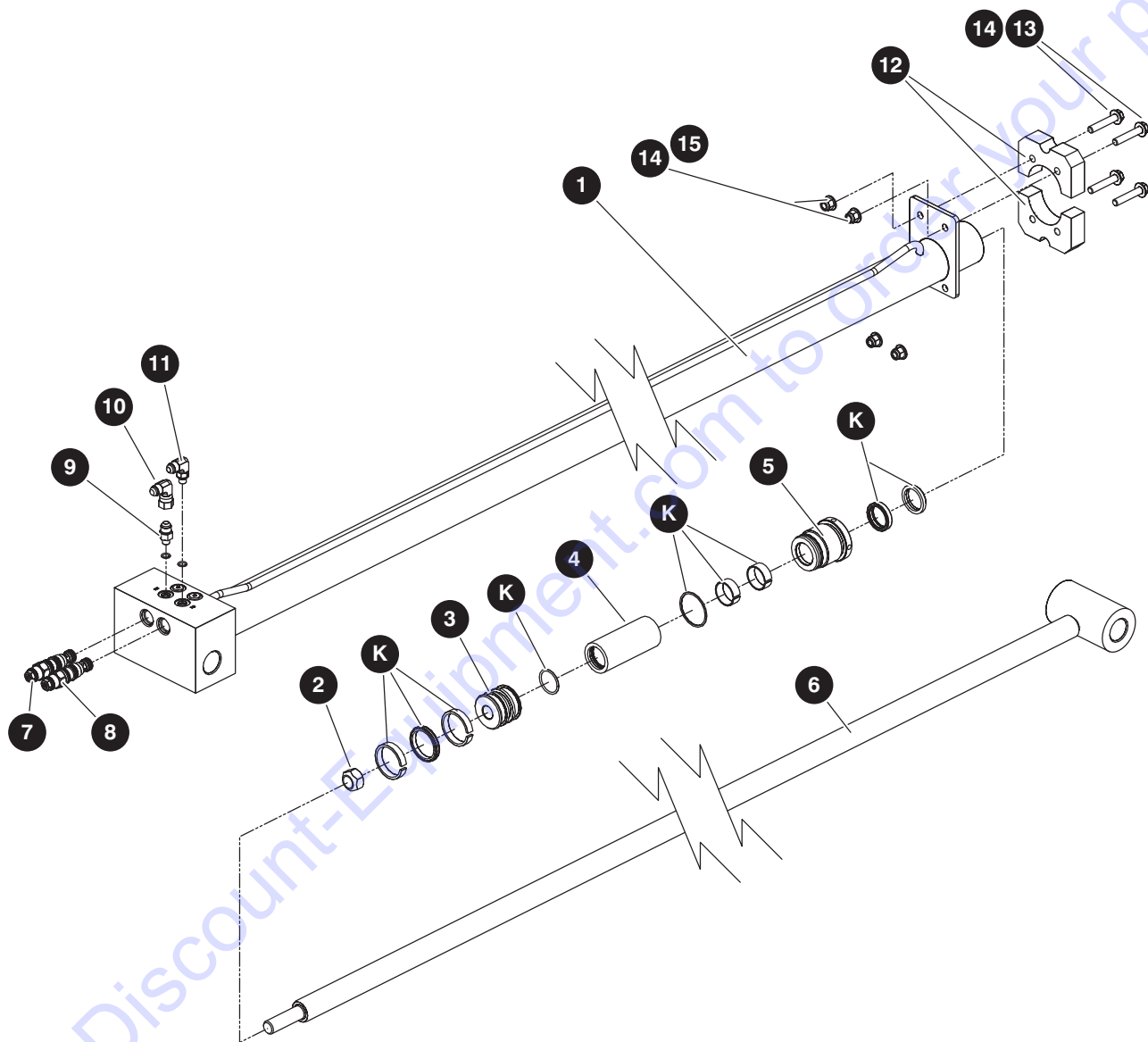

M148700AA

238271AAA

SJ45 AJ+

### 3.1 Extension Cylinder

Index No.	Skyjack Part No.	Qty.	Description
-	148700	1	EXTENSION CYLINDER
-	148712	1	• EXTENSION CYLINDER
1	154547	1	• • WELDMENT, Tube
2	154539	1	• • NUT, Rod
3	154543	1	• • PISTON
4	154546	1	• • STOP SLEEVE
5	154544	1	• • GLAND
6	154548	1	• • WELDMENT, Rod
7	141453	1	• • VALVE, Counterbalance (1000 psi)
8	149228	1	• • VALVE, Counterbalance (3000 psi)
9	103069	1	• FITTING, Straight (06 JICM - 06 ORBM)
10	702761	1	• FITTING, Elbow 90° (06 JICM - 06 JICFSW)
11	114578	1	• FITTING, Elbow 90° (06 JICM - 06 ORBM)
12	152417	2	• PAD, Wear
13	103596	4	• BOLT, Hex head (3/8"-16 x 2" Grade 5)
14	103472	8	• WASHER, Flat (3/8")
15	104606	4	• NUT, Hex lock (3/8"-16 Grade 5, nylon)
<b>K</b>	154537	1	SEAL KIT

## 3.2 Lift Cylinder

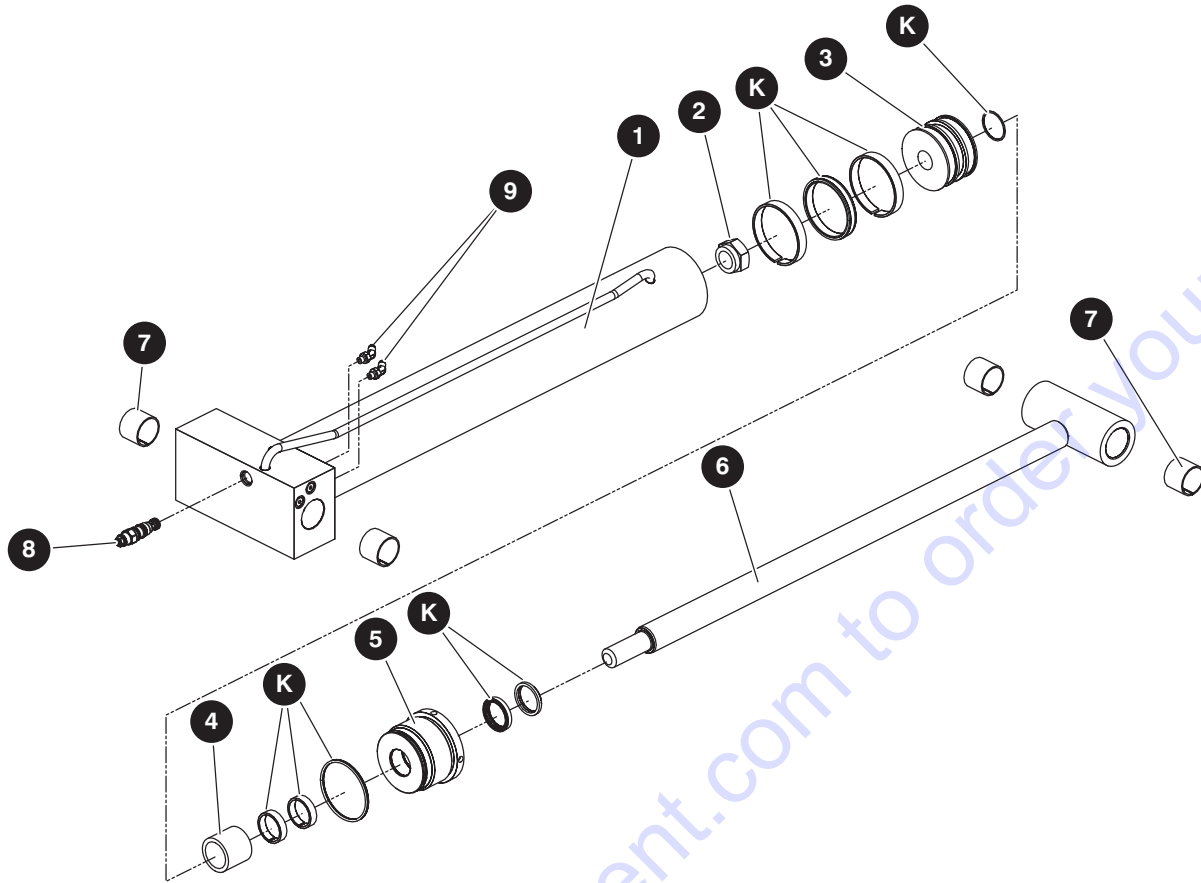

M148627AA

Index No.	Skyjack Part No.	Qty.	Description
-	220590	1	LIFT CYLINDER
-	210452	1	• CYLINDER, LIFT
1	229055	1	• • BARREL
2	154530	1	• • NUT, Rod
3	230692	1	• • PISTON
5	154535	1	• • GLAND
6	230693	1	• • ROD
7	154533	4	• • BEARING
8	152326	1	• • VALVE, Counterbalance
9	131716	2	• FITTING, Elbow 45° (04 JICM - 04 ORBM)
<b>K</b>	229058	1	SEAL KIT

### 3.3 Riser Cylinder Mounting

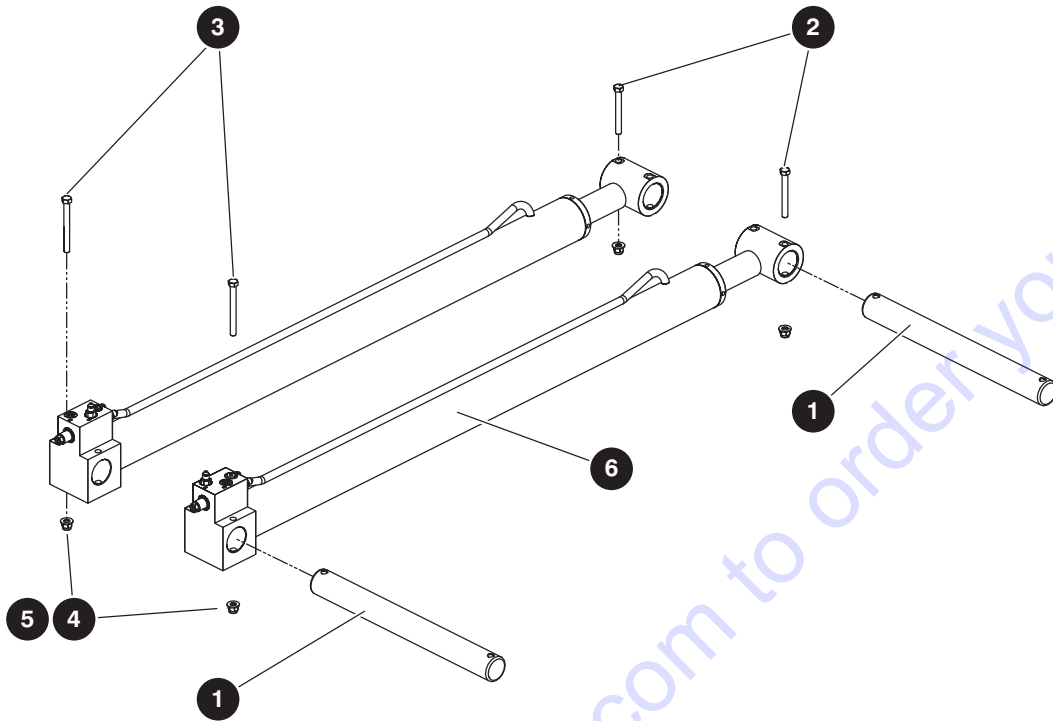

M148619AA

Index No.	Skyjack Part No.	Qty.	Description
1	158770	2	PIN (1 3/4" diameter x 15")
2	103916	2	BOLT, Hex head (3/8"-16 x 3 1/4" Grade 5)
3	152350	2	BOLT, Hex head (3/8"-16 x 4" Grade 5)
4	103472	4	WASHER, Flat (3/8")
5	104606	4	NUT, Hex lock (3/8"-16 Grade 5, nylon)
6	(Ref.)	2	RISER CYLINDER ASSEMBLY <a href="#">(For components, refer to 3.4 Riser Cylinder)</a>

### 3.4 Riser Cylinder

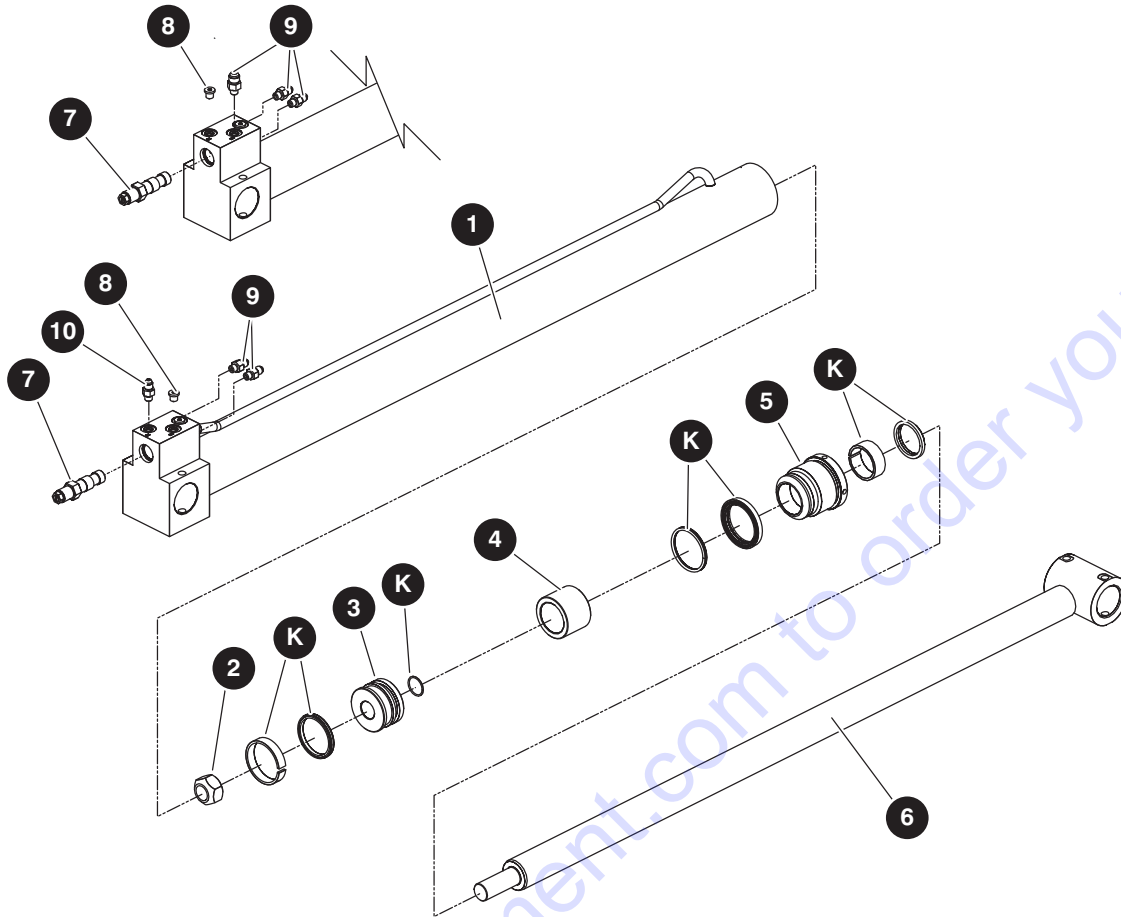

M148710AB

Index No.	Skyjack Part No.	Qty.	Description
-	148710	2	RISER CYLINDER ASSEMBLY
1	154563	1	• WELDMENT, Tube
2	152256	1	• NUT, Rod
3	154566	1	• PISTON
4	154568	1	• TUBE STOP
5	154567	1	• GLAND
6	154564	1	• WELDMENT, Rod
7	149488	1	• VALVE, Counterbalance
8	121250	2	• PLUG, Hex socket (04 ORBM)
9	128869	5	FITTING, Straight (06 JICM - 04 ORBM)
10	126128	1	FITTING, Straight (04 JICM - 04 ORBM)
<b>K</b>	154562	1	SEAL KIT



## 3.5 Master Cylinder

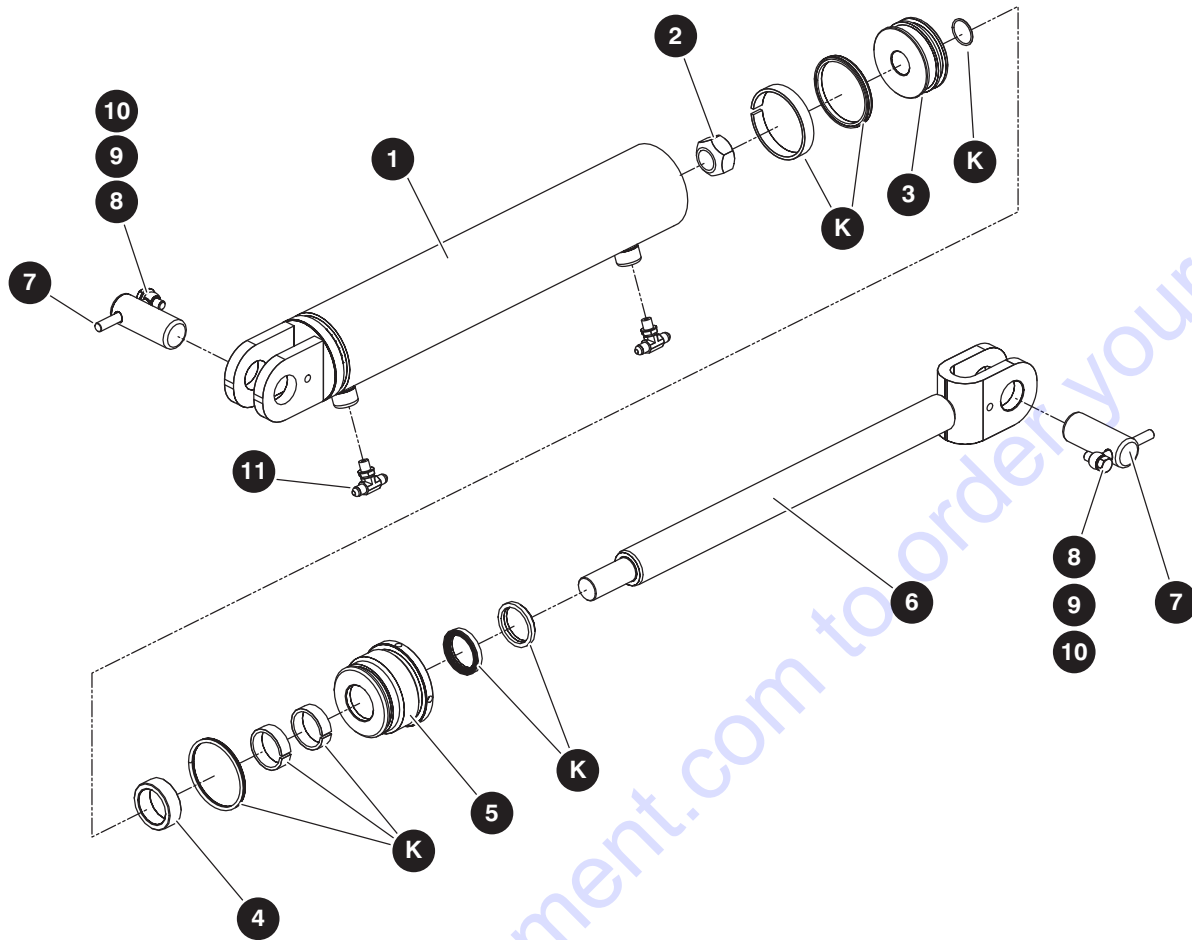

M148628AA

Index No.	Skyjack Part No.	Qty.	Description
-	148628	1	MASTER CYLINDER ASSEMBLY
-	148715	1	• MASTER CYLINDER
1	154525	1	• • WELDMENT, Tube
2	152256	1	• • NUT, Rod
3	154522	1	• • PISTON
4	154527	1	• • TUBE STOP
5	154523	1	• • GLAND
6	154526	1	• • WELDMENT, Rod
7	148846	2	• PIN (1 1/4" diameter x 3 1/8")
8	146897	2	• KEEPER PIN (3/8")
9	139193	2	• BOLT, Hex head patch (3/8"-16 x 7/8" Grade 8, ZP)
10	103472	2	• WASHER, Flat (3/8")
11	132463	2	• FITTING, Tee (04MJ04MB04MJ)
<b>K</b>	154524	1	SEAL KIT

## 3.6 Slave Cylinder

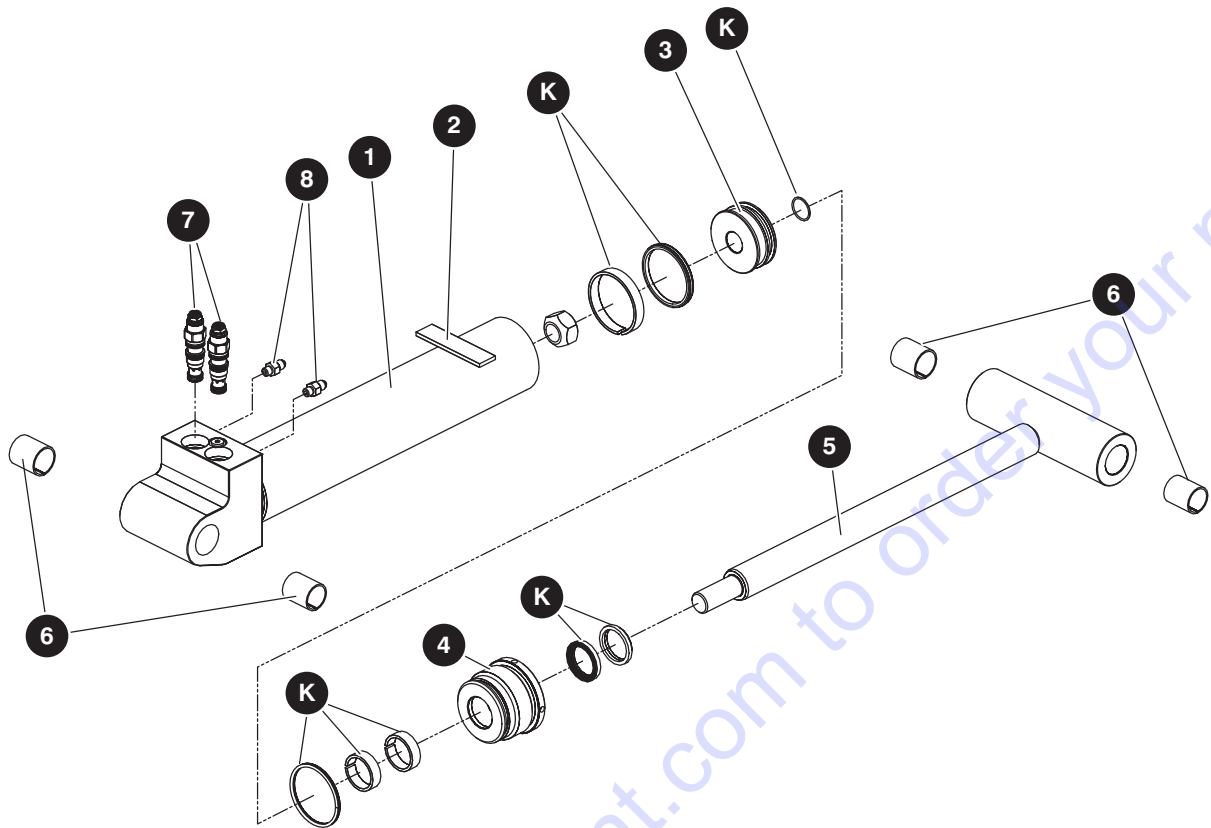

M148629AA

Index No.	Skyjack Part No.	Qty.	Description
-	148629	1	SLAVE CYLINDER ASSEMBLY
-	148716	1	• SLAVE CYLINDER
1	152255	1	• • WELDMENT, Tube
2	152256	1	• • NUT, Rod
3	154522	1	• • PISTON
4	154523	1	• • GLAND
5	154519	1	• • WELDMENT, Rod
6	154521	4	• • BEARING
7	701827	1	• • VALVE, Counterbalance
8	126128	2	• FITTING, Straight (04 JICM - 04 ORBM)
<b>K</b>	152254	1	SEAL KIT

### 3.7 Jib Cylinder

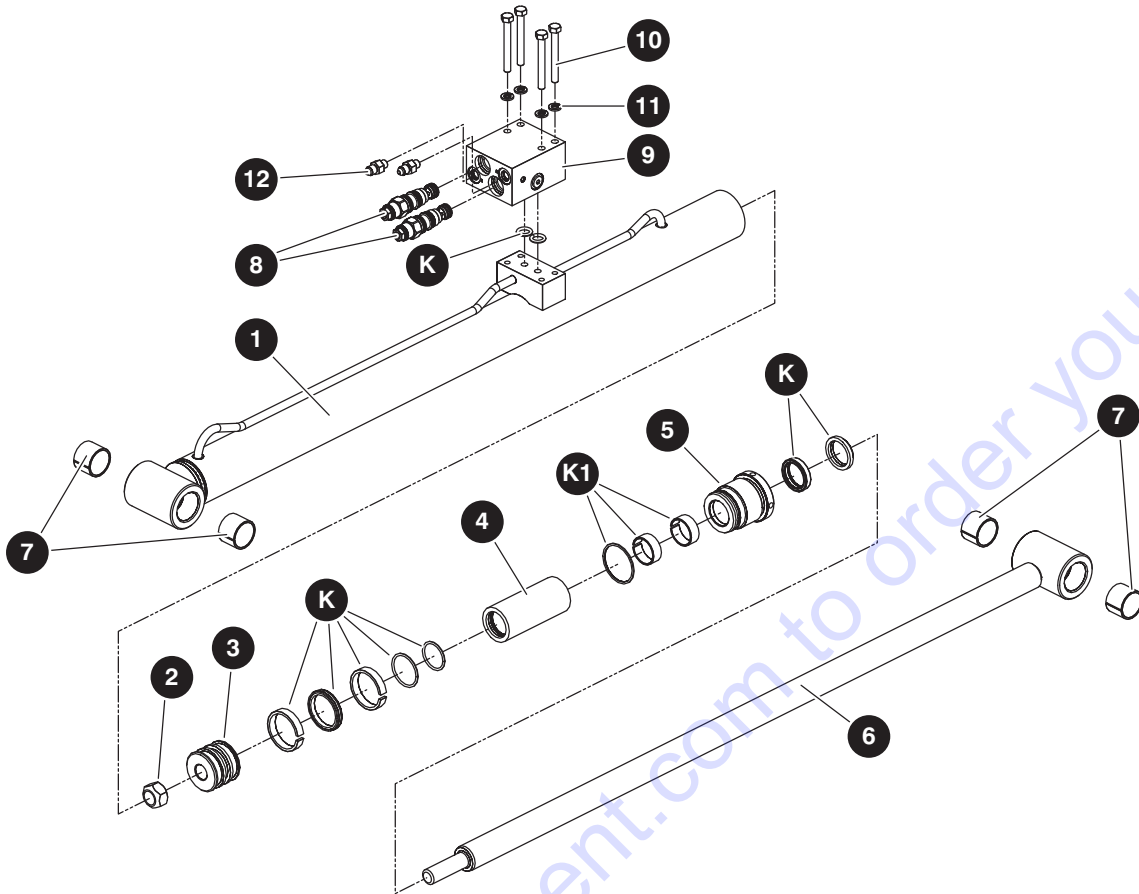

M148714AB

Index No.	Skyjack Part No.	Qty.	Description
-	218750	1	JIB CYLINDER
1	236648	1	• BARREL
2	154539	1	• NUT, Rod
3	236650	1	• PISTON
4	154546	1	• STOP SLEEVE
5	236651	1	• GLAND
6	236649	1	• ROD
7	236652	4	• BEARING
8	236654	1	• VALVE, Counterbalance
9	154556	1	• BLOCK, Manifold
10	154554	4	• BOLT, Hex head (5/16"-18 x 2 3/4" Grade 5, zinc)
11	154555	4	• WASHER, Flat zinc (5/16")
12	126128	2	• FITTING, Straight (04 JICM - 04 ORBM)
<b>K</b>	236653	1	SEAL KIT

### 3.8 Axle Lock Cylinder

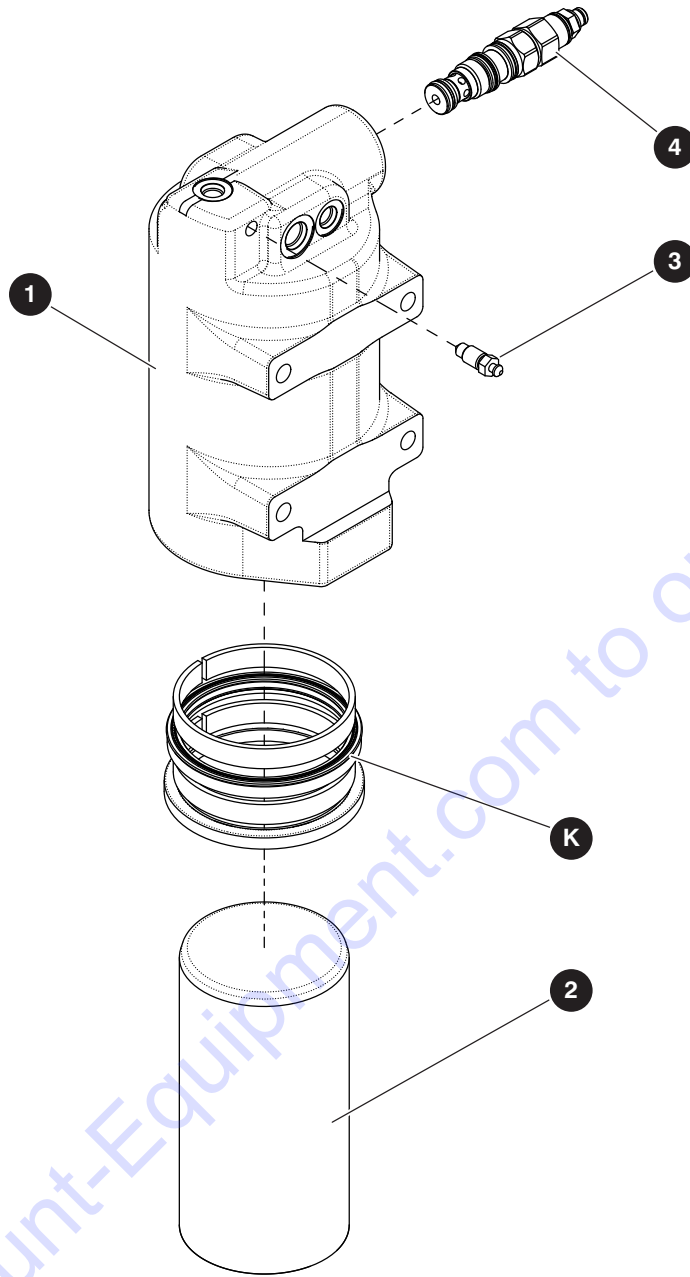

M198433AB

Index No.	Skyjack Part No.	Qty.	Description
-	212871	1	AXLE LOCK CYLINDER
1	154558	1	• BARREL
2	154559	1	• ROD
3	154561	1	• SCREW, Bleed
4	212872	1	• VALVE, Counterbalance - 4800 psi
K	154557	1	SEAL KIT, Axle lock cylinder

# Section 4 – Turret

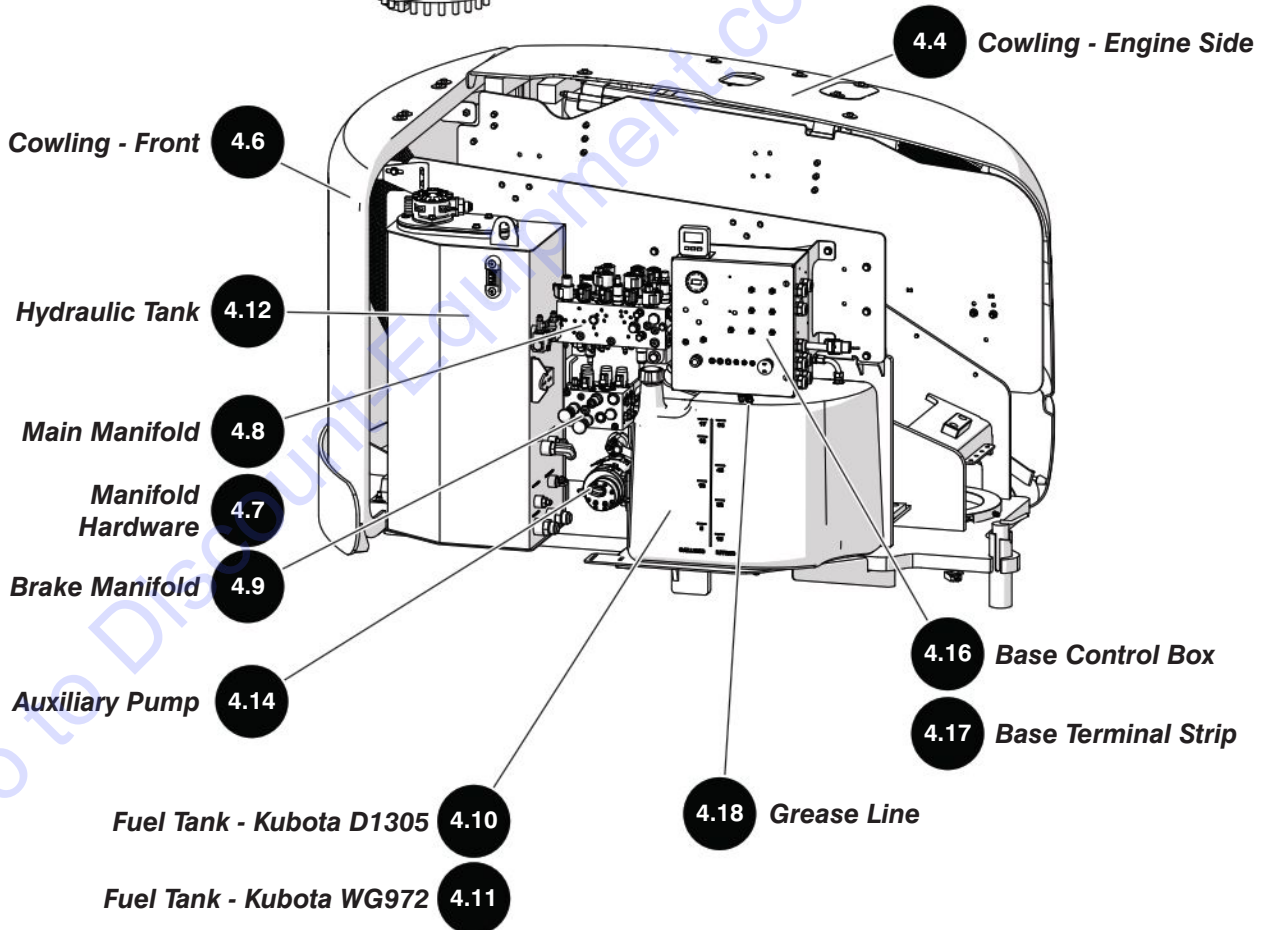
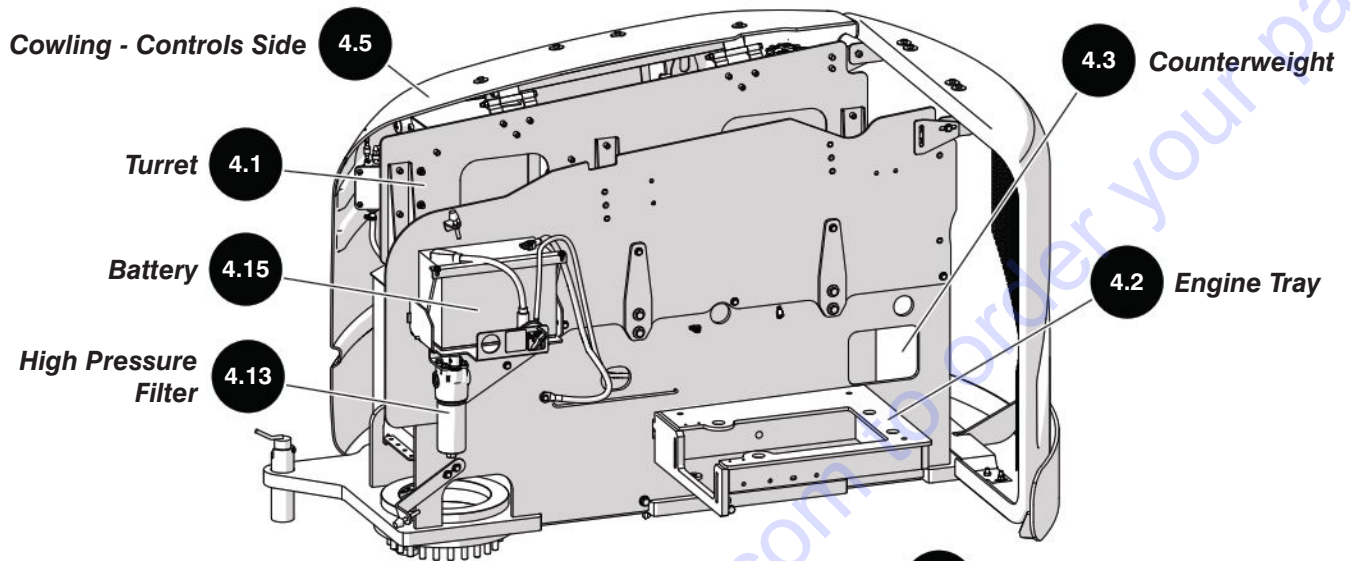

# 4.1 Turret

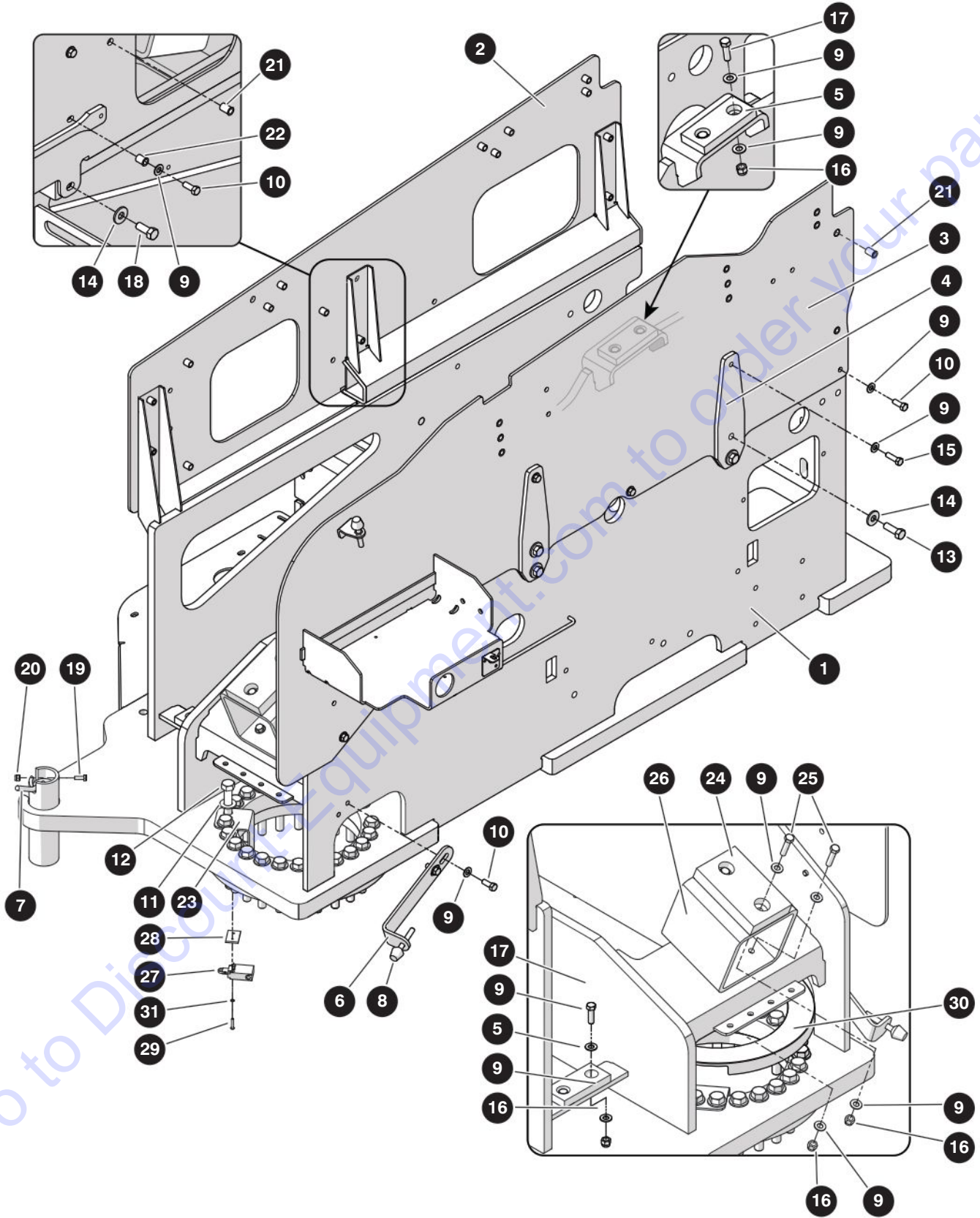

M237995AC

238271AAA

SJ45 AJ+

## 4.1 Turret

Index No.	Skyjack Part No.	Qty.	Description
-	237995	1	TURRET ASSEMBLY
1	237996	1	• WELDMENT, Turret
2	238361	1	• PLATE, Turret - upper left
3	238363	1	• PLATE, Turret - upper right
4	162292	2	• PLATE, Stiffener - turret
5	162293	2	• PAD, Guide (5.00" x 2.00" x 0.625")
6	162294	1	• BRACKET, Bumper - lower cowling
7	238049	1	• PIN, Transportation locking
8	116494	2	• BUMPER, Engine guard
9	103472	33	• WASHER, Lock (3/8")
10	103473	15	• BOLT, Hex head (3/8"-16 x 1" Grade 5)
11	700782	23	• WASHER, Flat hardened (5/8")
12	701762	23	• BOLT, Hex head (5/8"-11 x 4.5" Grade 8)
13	103907	4	• BOLT, Hex head (1/2"-13 x 1.5" Grade 5)
14	103468	5	• WASHER, Flat (1/2")
15	117430	2	• BOLT, Hex head (3/8"-16 x 1.25" Grade 8)
16	104606	8	• NUT, Hex head nylon lock (3/8"-16 Grade 5)
17	101297	4	• BOLT, Hex head (3/8"-16 x 1 1/4" Grade 5)
18	103910	1	• BOLT, Hex head (1/2"-13 x 1.25" Grade 8)
19	103856	1	• BOLT, Hex head (1/4"-20 x 0.75" Grade 5)
20	115649	1	• NUT, Hex head nylon lock (1/4"-20 Grade 5)
21	167459	25	• INSERT, 3/8"-16 AK series (0.150"-0.312")
22	167460	7	• INSERT, 3/8"-16 AK series (0.027"-0.150")
23	216472	1	• BRACKET, Limit switch
24	162293	1	• PAD, Guide (5.00" x 2.00" x 0.625")
25	101297	4	• BOLT, Hex head (0.375"-16 x 1.25" Grade 5)
26	238050	1	• TUBE, Boom rest
-	210399	1	DIRECTION SENSING LIMIT SWITCH ASSEMBLY
27	199486	1	• SWITCH, Limit - roller plunger (5 m)
28	211213	1	• PLATE, Limit switch - threaded
29	126499	2	• SCREW, Round head machine (8-32 x 0.875")
30	208815	1	• RING, Protector - plastic
31	122249	2	• WASHER, Lock (#8)

## 4.2 Engine Tray

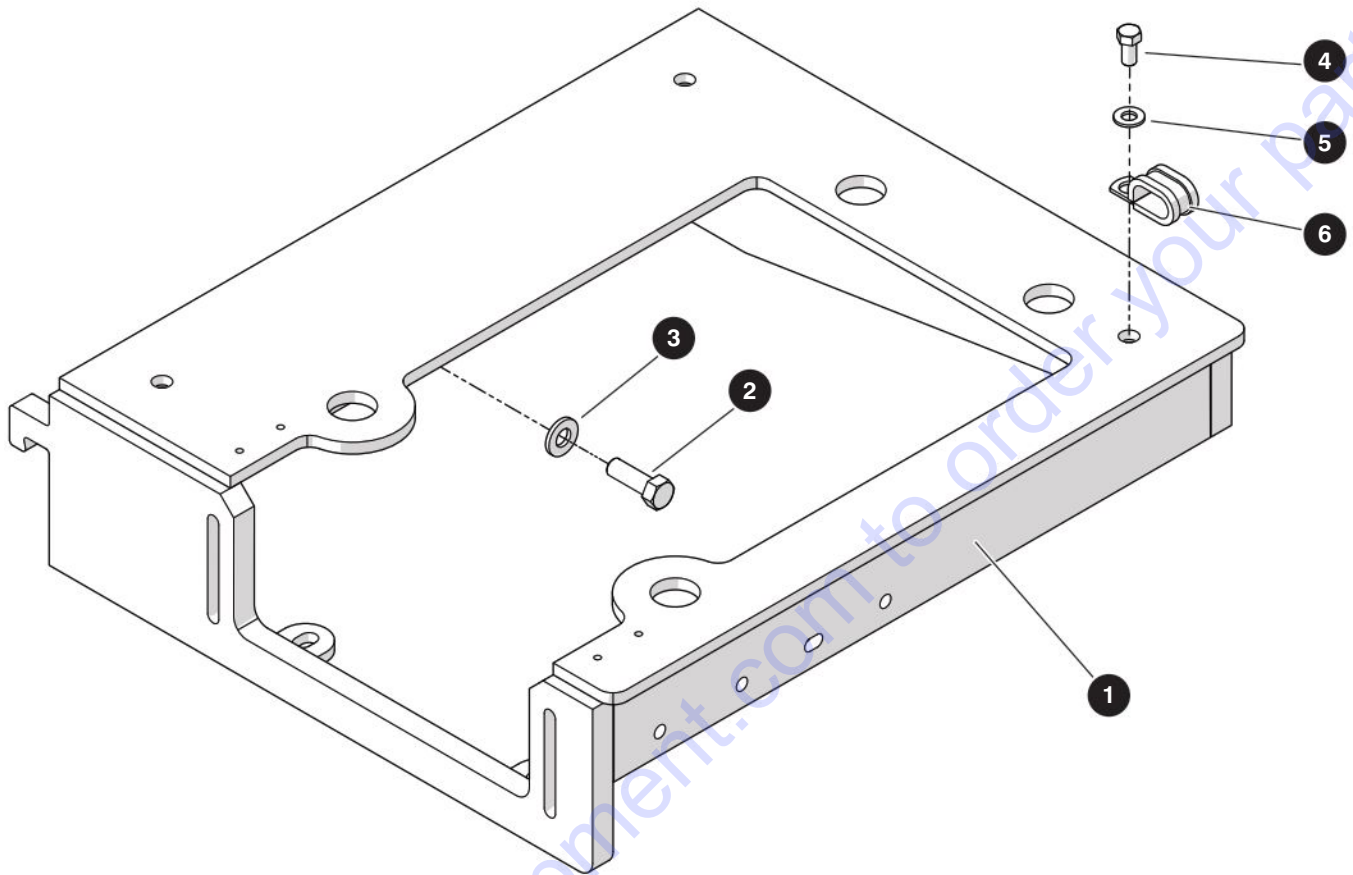

M238732AB

Index No.	Skyjack Part No.	Qty.	Description
-	238732	1	ENGINE TRAY ASSEMBLY
1	235796	1	• ENGINE TRAY WELDMENT
2	103907	3	• BOLT, Hex head (1/2"-13 x 1-1/2", gr 5)
3	104379	3	• WASHER, Flat hardened (1/2")
4	101632	1	• BOLT, Hex head (3/8"-16 x 3/4", gr 5)
5	125959	1	• WASHER, Flat hardened (3/8")
6	152333	1	• CLAMP, Tube - cushioned (5/8" with 17/32" hole)



## 4.3 Counterweight

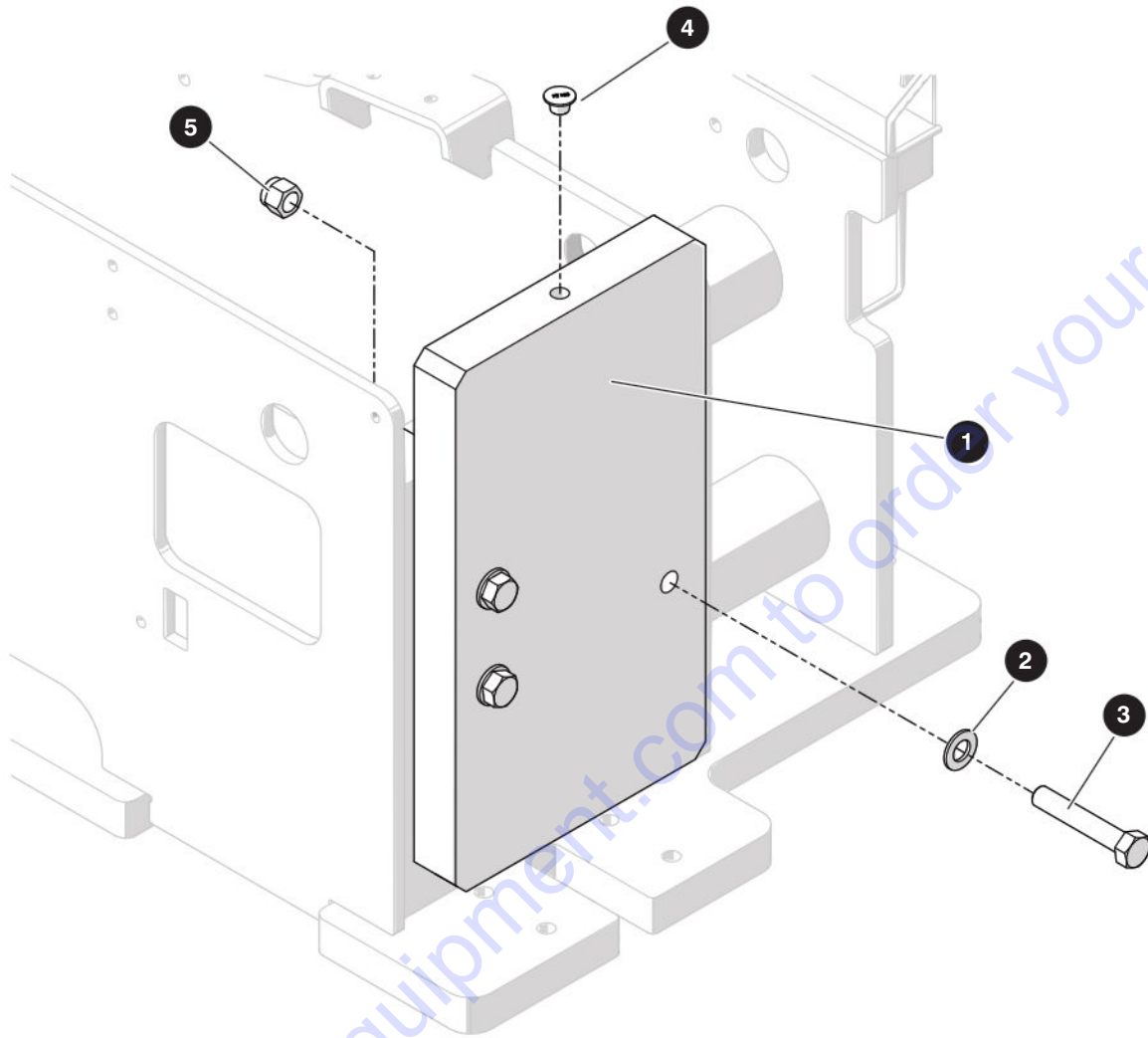

M239536AA

Index No.	Skyjack Part No.	Qty.	Description
-	239536	1	COUNTERWEIGHT
1	239537	1	• COUNTERWEIGHT
2	702194	6	• WASHER, Flat hardened (3/4")
3	191836	3	• BOLT, Hex head (3/4"-10 x 4-1/4", gr 8)
4	144105	1	• PLUG (3/4" threaded hole)
5	138266	3	• NUT, Lock (3/4"-10, gr 8)

## 4.4 Cowling - Engine Side

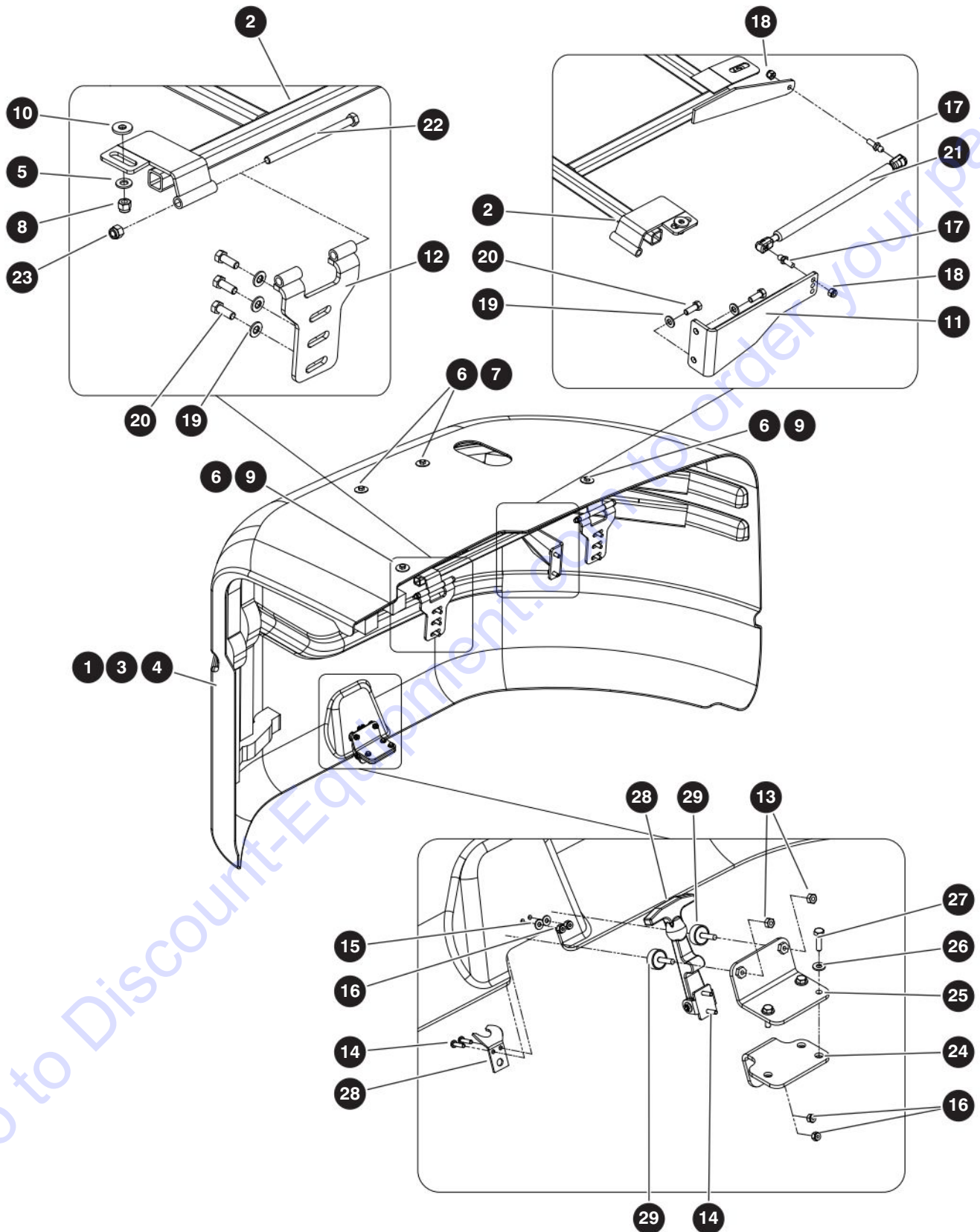

M148615AF

238271AAA

72

SJ45 AJ+

SKYJACK

## 4.4 Cowling - Engine Side

Index No.	Skyjack Part No.	Qty.	Description
-	218579	1	ENGINE SIDE COWLING
-	149259	1	• COWLING, Assembly (Engine Side)
1	149261	1	• • COWLING, Shell (Engine Side)
2	160214	1	• • WELDMENT, Cowling frame (Engine Side)
3	152426	2	• • PLATE, Perforated
4	148368	1	• • FOAM, 2" x 2" (#1441FR)
5	125959	4	• • WASHER, Flat hardened (3/8")
6	127067	4	• • WASHER, Flat (3/8" Style BB)
7	101297	2	• • BOLT, Hex head (3/8"-16 x 1 1/4" Grade 5)
8	104606	4	• • NUT, Hex lock (3/8"-16 Grade 5, nylon)
9	103870	2	• • BOLT, Hex head (3/8"-16 x 1 1/2" Grade 5)
10	152416	2	• • WASHER, Rubber (1x 3/7 x 1/8 TK)
11	149360	1	• WELDMENT, Gas spring mount
12	152427	2	• WELDMENT, Hinge lower RHS
13	103980	2	• NUT, Hex head (1/4"-20 Grade 8)
14	138834	4	• SCREW, Round machine (#10-24 x 3/4")
15	104694	2	• WASHER, Flat (#10)
16	126642	4	• NUT, Hex lock (#10-24 Grade 5, nylon)
17	146903	2	• STUD, Ball (10mm)
18	103984	2	• NUT, Hex lock (5/16"-18 Grade 5, nylon)
19	125959	10	• WASHER, Flat hardened (3/8")
20	103473	10	• BOLT, Hex head (3/8"-16 x 1" Grade 5)
21	152431	1	• GAS SPRING, Cowling
22	138736	2	• BOLT, Hex head (3/8"-16 x 6" Grade 5)
23	104606	2	• NUT, Hex lock (3/8"-16 Grade 5, nylon)
24	149333	1	• WELDMENT, Latch mount
25	149334	1	• WELDMENT, Cowling bumper
26	103995	3	• WASHER, Flat (1/4")
27	103857	3	• BOLT, Hex head (1/4"-20 x 1" Grade 5)
28	144002	1	• LATCH, Flexible draw
29	144015	2	• MOUNT, Anti-vibration

## 4.5 Cowling - Controls Side

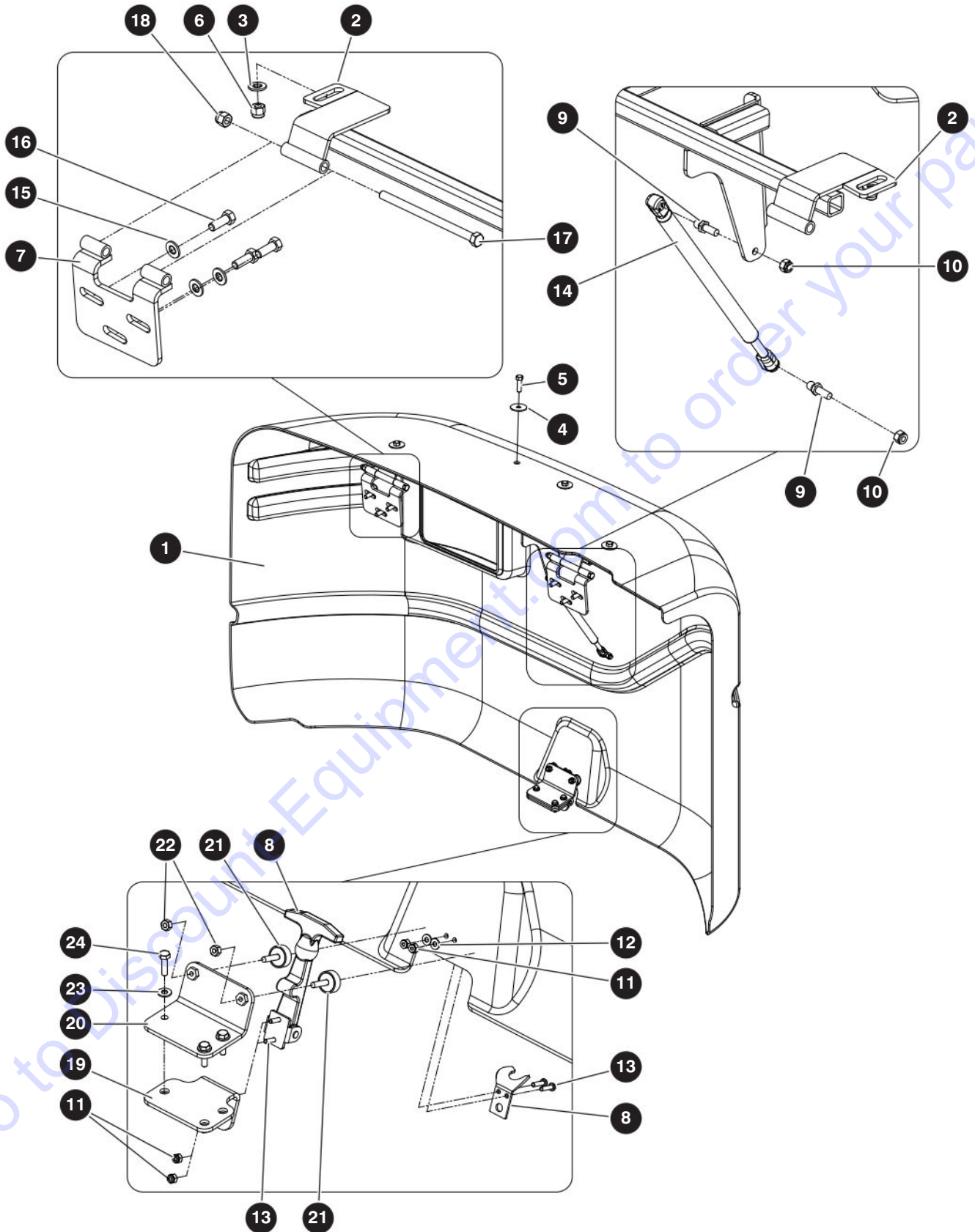

M148614AE

238271AAA

SJ45 AJ+

## 4.5 Cowling - Controls Side

Index No.	Skyjack Part No.	Qty.	Description
-	218576	1	CONTROLS SIDE COWLING
-	149260	1	• COWLING, Assembly (Controls Side)
1	149262	1	• • COWLING, Shell (Controls Side)
2	160204	1	• • WELDMENT, Cowling frame (Controls Side)
3	125959	4	• • WASHER, Flat hardened (3/8")
4	127067	4	• • WASHER, Flat (3/8" Style BB)
5	101297	4	• • BOLT, Hex head (3/8"-16 x 1 1/4" Grade 5)
6	104606	4	• • NUT, Hex lock (3/8"-16 Grade 5, nylon)
7	149483	2	• WELDMENT, Hinge lower LHS
8	144002	1	• LATCH, Flexible draw
9	146903	2	• STUD, Ball (10mm)
10	103984	2	• NUT, Hex lock (5/16"-18 Grade 5, nylon)
11	126642	4	• NUT, Hex lock (#10-24 Grade 5, nylon)
12	104694	2	• WASHER, Flat (#10)
13	138834	4	• SCREW, Round machine (#10-24 x 3/4")
14	152431	1	• GAS SPRING, Cowling
15	125959	6	• WASHER, Flat hardened (3/8")
16	103473	6	• BOLT, Hex head (3/8"-16 x 1" Grade 5)
17	138736	2	• BOLT, Hex head (3/8"-16 x 6" Grade 5)
18	104606	2	• NUT, Hex lock (3/8"-16 Grade 5, nylon)
19	149333	1	• WELDMENT, Latch mount
20	149334	1	• WELDMENT, Cowling bumper
21	144015	2	• MOUNT, Anti-vibration
22	103980	2	• NUT, Hex head (1/4"-20 Grade 8)
23	103995	3	• WASHER, Flat (1/4")
24	103857	3	• BOLT, Hex head (1/4"-20 x 1" Grade 5)

## 4.6 Cowling - Front

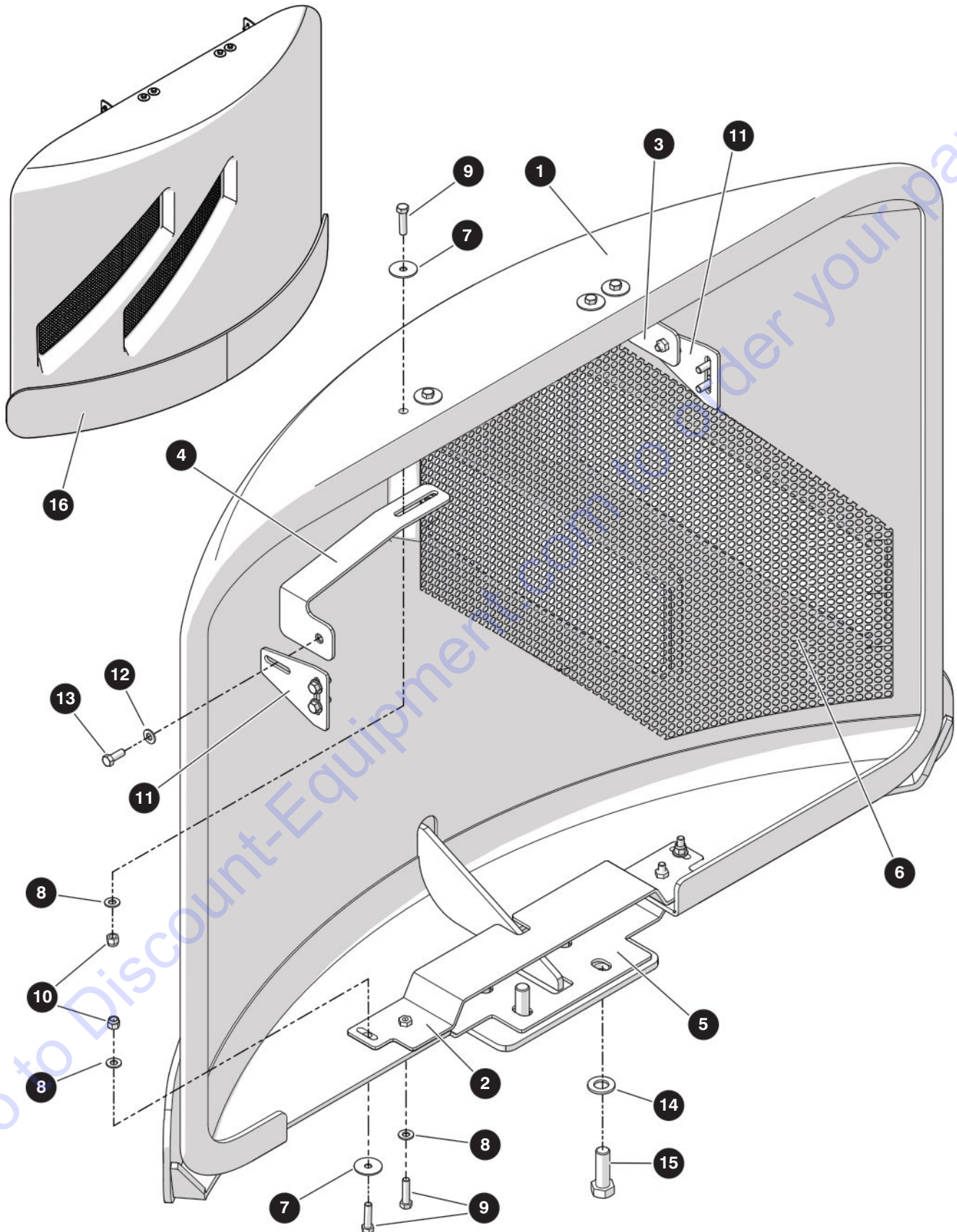

M230854AA

238271AAA

76

SJ45 AJ+

SKYJACK

## 4.6 Cowling - Front

Index No.	Skyjack Part No.	Qty.	Description
-	238335	1	FRONT COWLING
-	238336	1	• COWLING, Front
1	238337	1	• • COWLING SHELL, Front
2	238338	1	• • BRACKET, Cowling - bottom
3	238340	1	• • BRACKET, Cowling - top RH
4	238342	1	• • BRACKET, Cowling - top LH
5	238344	1	• • BRACKET, Mounting
6	238345	1	• • PLATE, Perforated
7	127067	6	• • WASHER, Flat BB style (3/8")
8	125959	8	• • WASHER, Flat hardened (3/8")
9	103870	8	• • BOLT, Hex head (3/8"-16 x 1-1/2", gr 5)
10	104606	6	• • NUT, Lock (3/8"-16, gr 5)
11	238346	2	• PLATE, Mounting
12	125959	6	• WASHER, Flat hardened (3/8")
13	103476	6	• BOLT, Hex head (3/8"-16 x 1", gr 5)
14	702194	4	• WASHER, Flat hardened (3/4")
15	153606	4	• BOLT, Hex head (3/4"-10 x 2 1/4", gr 8)
16	238837	1	PROTECTION, Cowling - <b>CE</b>

## 4.7 Manifold Hardware

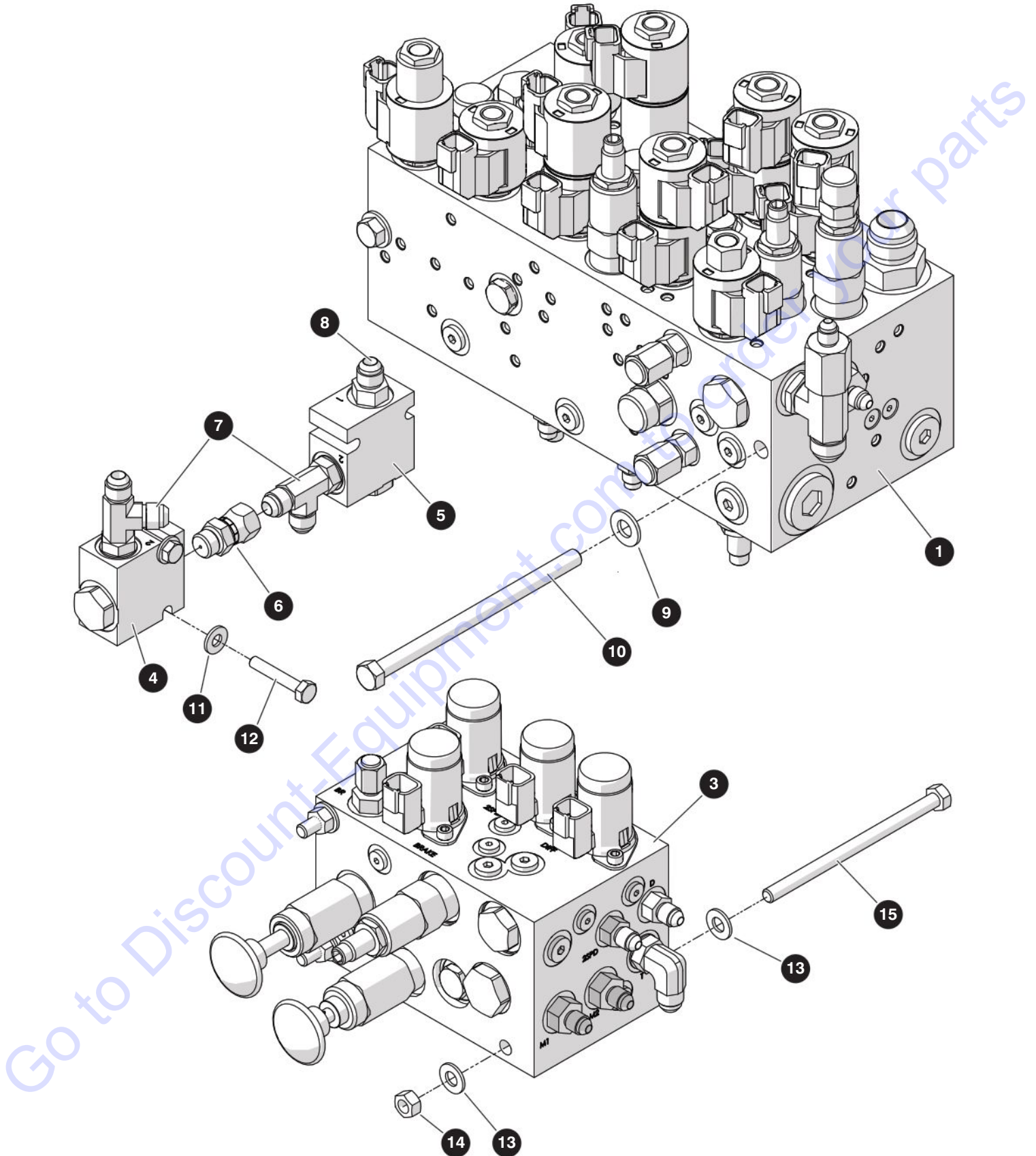

M230147AB

238271AAA



## 4.7 Manifold Hardware

Index No.	Skyjack Part No.	Qty.	Description
-	230147	1	MANIFOLD ASSEMBLY WITH HARDWARE
1	(Ref.)	1	<ul style="list-style-type: none"> <li>MAIN MANIFOLD (For components, refer to 4.8 Main Manifold)</li> </ul>
3	(Ref.)	1	<ul style="list-style-type: none"> <li>BRAKE MANIFOLD (For components, refer to 4.9 Brake Manifold)</li> </ul>
-	213881	1	<ul style="list-style-type: none"> <li>LINE BODY VALVE</li> </ul>
4	163182	1	<ul style="list-style-type: none"> <li>VALVE ASSEMBLY, Check</li> </ul>
	166075	1	<ul style="list-style-type: none"> <li>BLOCK, Check Valve</li> </ul>
	159815	1	<ul style="list-style-type: none"> <li>VALVE, Check</li> </ul>
5	163183	1	<ul style="list-style-type: none"> <li>VALVE ASSEMBLY, Check</li> </ul>
	166075	1	<ul style="list-style-type: none"> <li>BLOCK, Check Valve</li> </ul>
	166066	1	<ul style="list-style-type: none"> <li>VALVE, Check</li> </ul>
6	228312	1	<ul style="list-style-type: none"> <li>FITTING, Straight (06JIC-06ORBM, 0.67 orifice)</li> </ul>
7	114581	2	<ul style="list-style-type: none"> <li>FITTING, Tee (06 JICM - 06 ORBM - 06 JICM)</li> </ul>
8	103069	1	<ul style="list-style-type: none"> <li>FITTING, Straight (06 JICM - 06 ORBM)</li> </ul>
9	125959	2	<ul style="list-style-type: none"> <li>WASHER, Flat hardened (3/8")</li> </ul>
10	138736	2	<ul style="list-style-type: none"> <li>BOLT, Hex head (0.375"-16 x 6.00 gr 5)</li> </ul>
11	103995	2	<ul style="list-style-type: none"> <li>WASHER, Flat (1/4")</li> </ul>
12	103859	2	<ul style="list-style-type: none"> <li>BOLT, Hex head (1/4"-20 x 1.50" Grade 5)</li> </ul>
13	103996	8	<ul style="list-style-type: none"> <li>WASHER, Flat (5/16")</li> </ul>
14	100397	3	<ul style="list-style-type: none"> <li>NUT, Hex head (5/16"-18, Grade 5)</li> </ul>
15	138762	3	<ul style="list-style-type: none"> <li>BOLT, Hex head (5/16"-18 x 5.00", Grade 5)</li> </ul>

# 4.8 Main Manifold

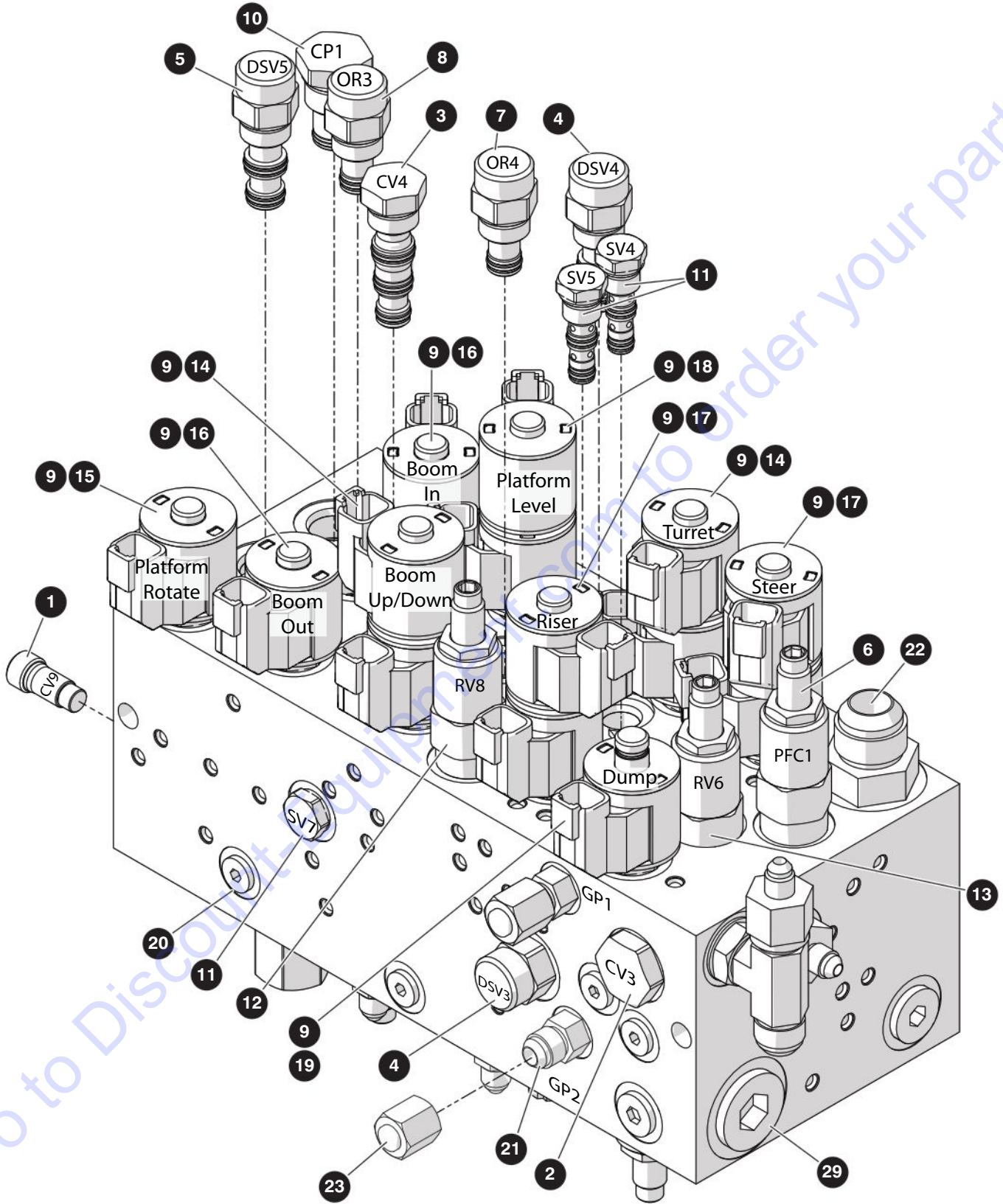

M218327AA-1

238271AAA

SJ45 AJ+

## 4.8 Main Manifold

Index No.	Skyjack Part No.	Qty.	Description
-	218327	1	MAIN MANIFOLD
1	166067	1	• VALVE, Check
2	166064	1	• VALVE, Check
3	159817	1	• VALVE, Check (Pilot operated)
4	166063	2	• COMPENSATOR, Pressure
5	166062	1	• COMPENSATOR, Pressure
6	166055	1	• REGULATOR, Pressure
7	166057	1	• REGULATOR, Pressure
8	166056	1	• REGULATOR, Pressure
9	159821	14	• COIL, 12 VDC
10	231437	1	• PLUG, Cavity
11	166054	5	• VALVE, Shuttle
12	166044	1	• VALVE, Differential relief
13	166043	1	• VALVE, Differential relief
14	166041	3	• VALVE, Spool (3 position 4 way)
15	231438	1	• VALVE, Spool (2 position 2 way)
16	166037	2	• VALVE, Spool (3 way)
17	158186	1	• VALVE, Spool (3 position 4 way)
18	166036	1	• VALVE, Spool (3 position 4 way)
19	166039	1	• VALVE, Spool (2 way)
20	121250	3	• PLUG, Hex socket (04 ORBM)
21	128869	2	• FITTING, Straight (06 JICM - 06 ORBM)
22	702118	1	• FITTING, Straight (12 JICM - 12 ORBM)
23	107666	2	• FITTING, Cap (06 JICF)
			<b><i>The parts list is continued on the next page.</i></b>

## 4.8 Main Manifold

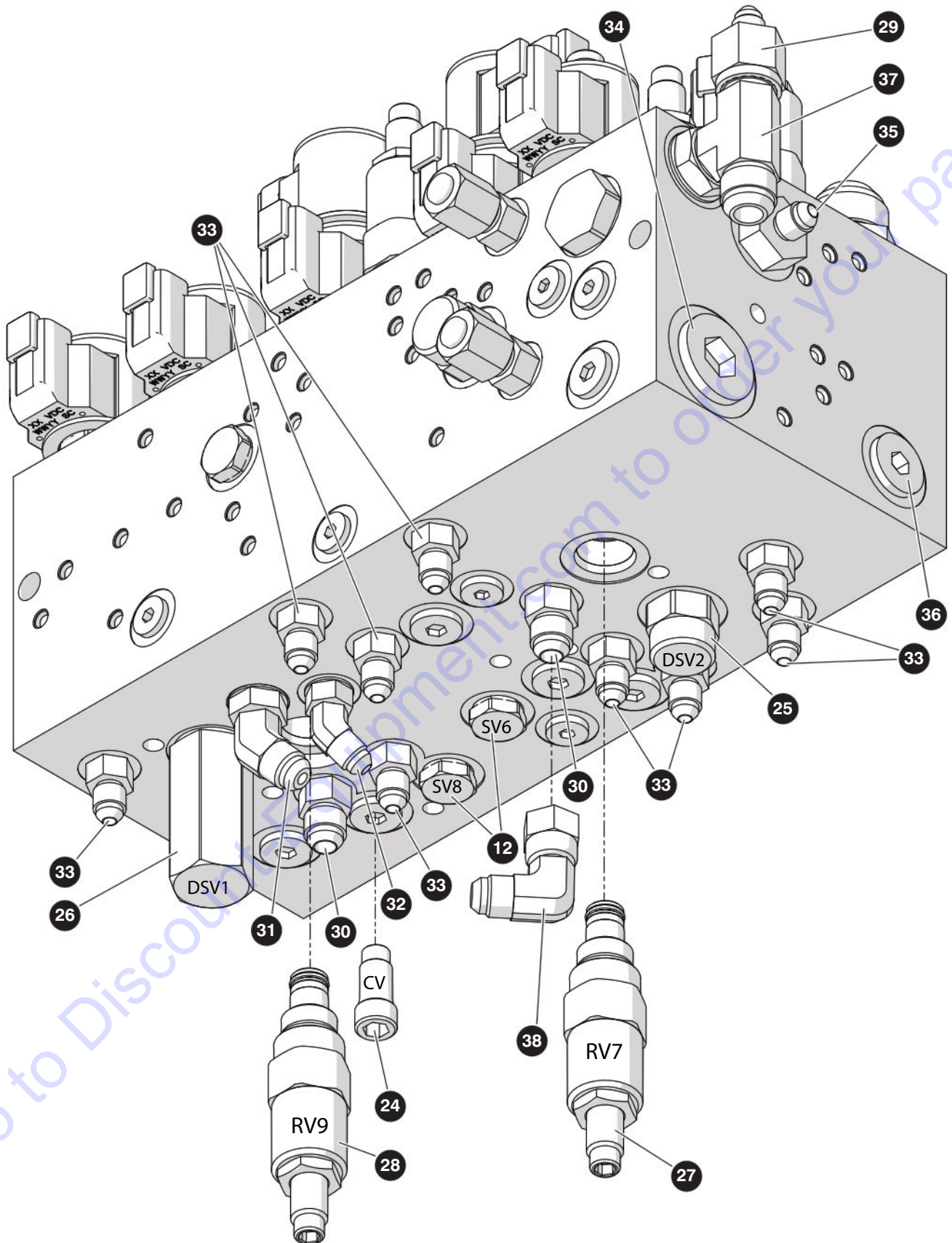

M218327AA-2

238271AAA

SJ45 AJ+

## 4.8 Main Manifold

Index No.	Skyjack Part No.	Qty.	Description
<i>The parts list is continued from the previous page.</i>			
24	166067	5	<ul style="list-style-type: none"> <li>• VALVE, Check</li> </ul>
25	166062	1	<ul style="list-style-type: none"> <li>• COMPENSATOR, Pressure</li> </ul>
26	166059	1	<ul style="list-style-type: none"> <li>• COMPENSATOR, Pressure</li> </ul>
27	168975	1	<ul style="list-style-type: none"> <li>• VALVE, Relief</li> </ul>
28	159809	1	<ul style="list-style-type: none"> <li>• VALVE, Relief</li> </ul>
29	706812	1	<ul style="list-style-type: none"> <li>• FITTING, Straight (08 JICF - 04 JICM)</li> </ul>
30	128869	2	<ul style="list-style-type: none"> <li>• FITTING, Straight (06 JICM - 06 ORBM)</li> </ul>
31	701478	1	<ul style="list-style-type: none"> <li>• FITTING, Elbow 45° (06 JICM - 04 ORBM)</li> </ul>
32	131716	1	<ul style="list-style-type: none"> <li>• FITTING, Elbow 45° (04 JICM - 04 ORBM)</li> </ul>
33	126128	10	<ul style="list-style-type: none"> <li>• FITTING, Straight (04 JICM - 04 ORBM)</li> </ul>
34	111392	1	<ul style="list-style-type: none"> <li>• PLUG, Hex socket (12 ORBM)</li> </ul>
35	131705	1	<ul style="list-style-type: none"> <li>• FITTING, Straight (08 ORBM - 04 JICM)</li> </ul>
36	702796	1	<ul style="list-style-type: none"> <li>• PLUG, Hex socket (08 ORBM)</li> </ul>
37	135061	1	<ul style="list-style-type: none"> <li>• FITTING, Tee (08 JICM - 08 JICM - 08 ORBM)</li> </ul>
38	702761	1	<ul style="list-style-type: none"> <li>• FITTING, Elbow 90° (06 JICM - 06 JICFSW)</li> </ul>

## 4.9 Brake Manifold

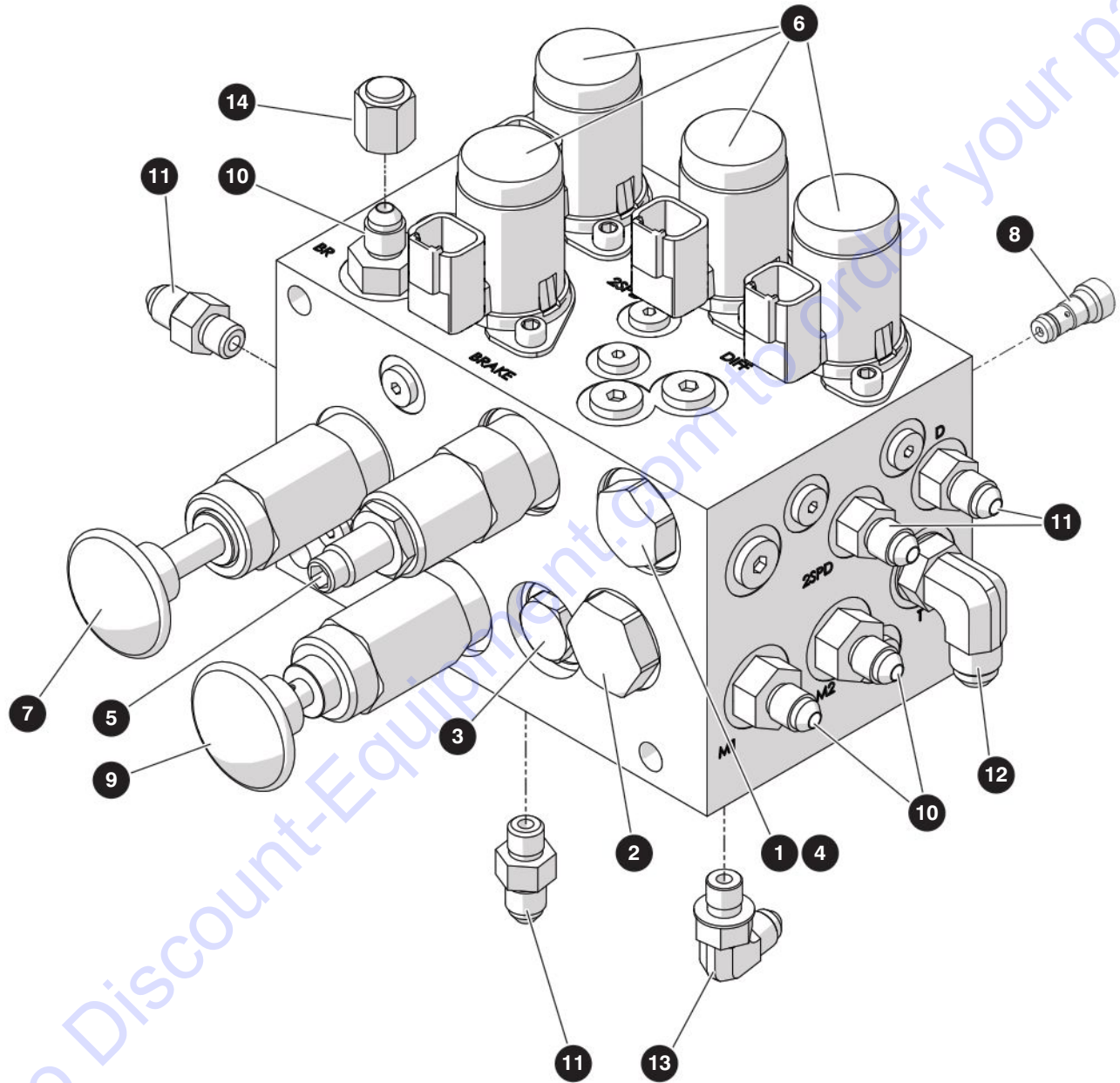

M195803AC

238271AAA

SJ45 AJ+

## 4.9 Brake Manifold

Index No.	Skyjack Part No.	Qty.	Description
-	195803	1	BRAKE MANIFOLD
-	168642	1	• MANIFOLD, Brake
1	171413	1	• • VALVE, Check
2	166053	1	• • VALVE, Shuttle
3	166054	1	• • VALVE, Shuttle
4	171420	1	• • ORIFICE, Disc (0.073")
5	168754	1	• • VALVE, Pressure reducer
6	159827	4	• • VALVE, Solenoid
7	159831	1	• • PUMP, Hand
8	141414	1	• • VALVE, Shuttle
9	141436	1	• • VALVE, Brake release override
10	701956	3	• FITTING, Straight (04 JICM - 06 ORBM)
11	126128	4	• FITTING, Straight (04 JICM - 04 ORBM)
12	114578	1	• FITTING, 90° elbow (06 JICM - 06 ORBM)
13	125883	1	• FITTING, 90° elbow (04 JICM - 04 ORBM)
14	131286	1	• FITTING, Cap (04 JICF)

## 4.10 Fuel Tank - Kubota D1305

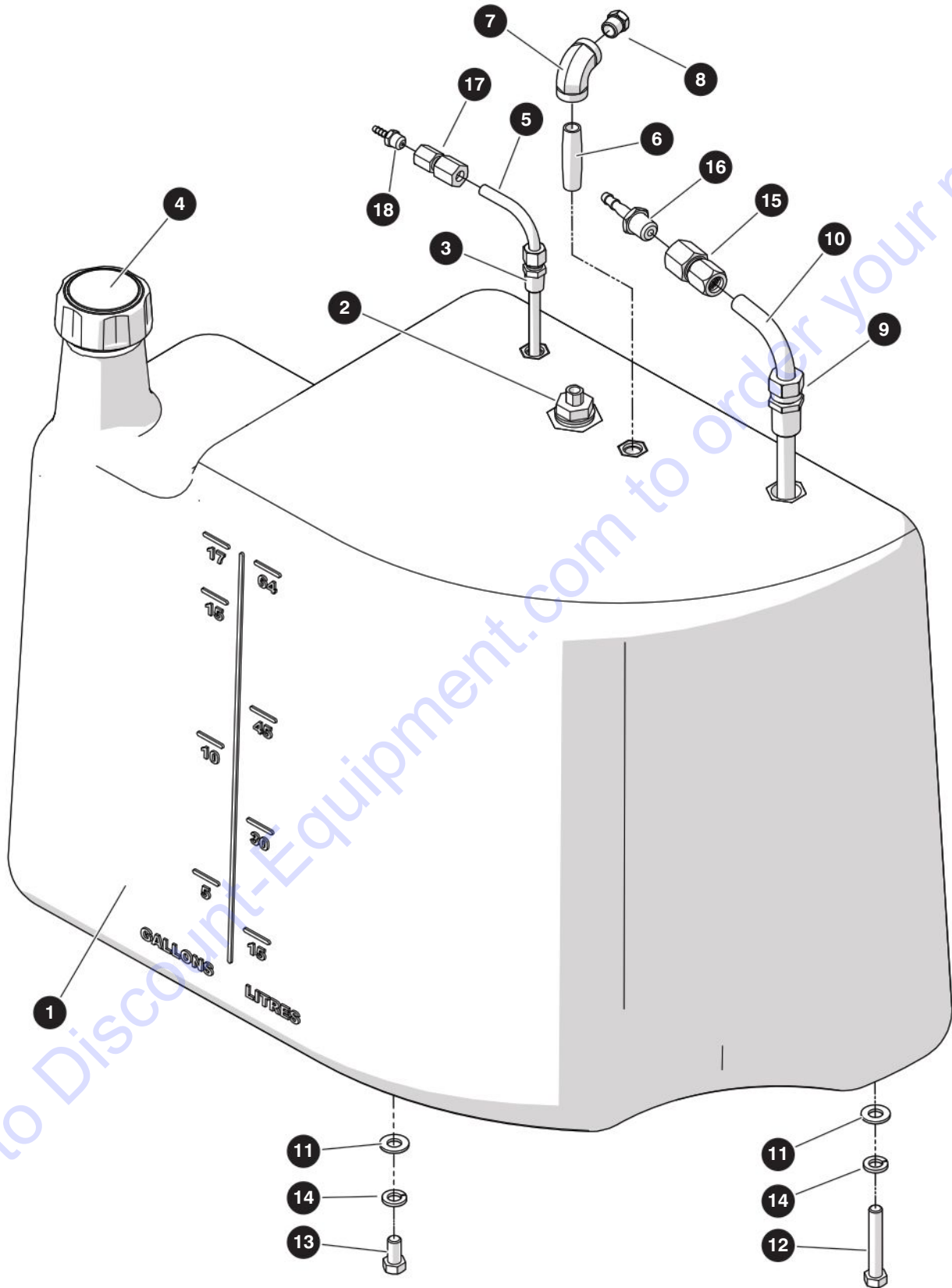

M238514AB

238271AAA

SJ45 AJ+



## 4.10 Fuel Tank - Kubota D1305

Index No.	Skyjack Part No.	Qty.	Description
-	238514	1	FUEL TANK
-	210465	1	• FUEL TANK, Diesel
1	210466	1	• • TANK, Fuel - diesel
2	103155	1	• • FITTING, Brass tank (#T68-5B)
3	138491	1	• • TUBE, Fuel send/return
4	144410	1	• • CAP, Fuel (Non EPA)
5	138230	1	• • SWITCH, Fuel level
6	116408	1	• • BREATHER VENT (1/4" NPT)
7	143478	1	• • FITTING, Brass nipple (1/4" NPT x 2" lg)
8	144325	1	• • FITTING, Brass 90° (1/4" NPTF x 1/4" NPTF)
9	164674	1	• • FITTING, Compression tube (1/2" OD x 1/2" NPT)
10	164673	1	• • TUBE, Fuel suction
11	125959	4	• WASHER, Flat hardened (3/8")
12	103872	2	• BOLT, Hex head (3/8"-16 x 2-1/4", gr 5)
13	101632	2	• BOLT, Hex head (3/8"-16 x 3/4", gr 5)
14	103999	4	• WASHER, Lock (3/8")
15	165716	1	• FITTING, Straight (08BT-06FP)
16	165719	1	• FITTING, Hose barb - beaded (5/16" tube)
17	237600	1	• FITTING, Straight adapter (05BT-02FP)
18	237603	1	• FITTING, Hose barb (1/8" line)

# 4.11 Fuel Tank - Kubota WG972

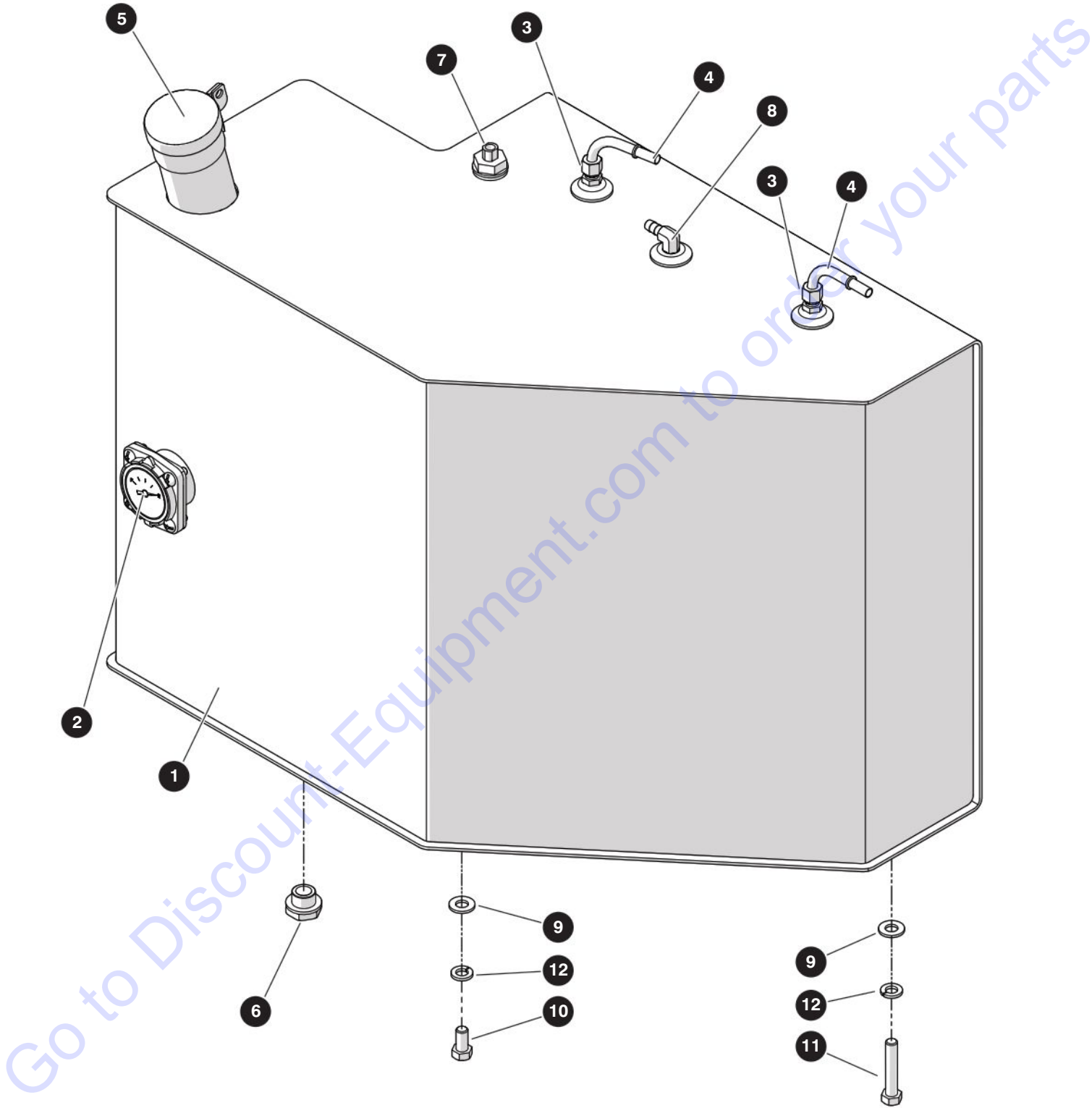

M238722AB

238271AAA

## 4.11 Fuel Tank - Kubota WG972

Index No.	Skyjack Part No.	Qty.	Description
-	238722	1	FUEL TANK - Kubota WG972
-	238727	1	• FUEL TANK, Gasoline
1	238728	1	• • TANK, Fuel
2	144393	4	• • GAUGE, Fuel level
3	103155	1	• • FITTING, Brass tank (#T68-5B)
4	144338	2	• • TUBE, Gas send/return
5	238744	1	• • CAP, Filler - non-vented
6	117701	1	• • PLUG, Tank - magnetic (3/4" UNF)
7	138230	1	• • SWITCH, Fuel level
8	102907	1	• • FITTING, Brass - 90° (5/16" hose 1/4" NPT)
9	125959	4	• WASHER, Flat hardened (3/8")
10	101632	2	• BOLT, Hex head (3/8"-16 x 3/4", gr 5)
11	103596	2	• BOLT, Hex head (3/8"-16 x 2", gr 5)
12	103999	4	• WASHER, Lock (3/8")

## 4.12 Hydraulic Tank

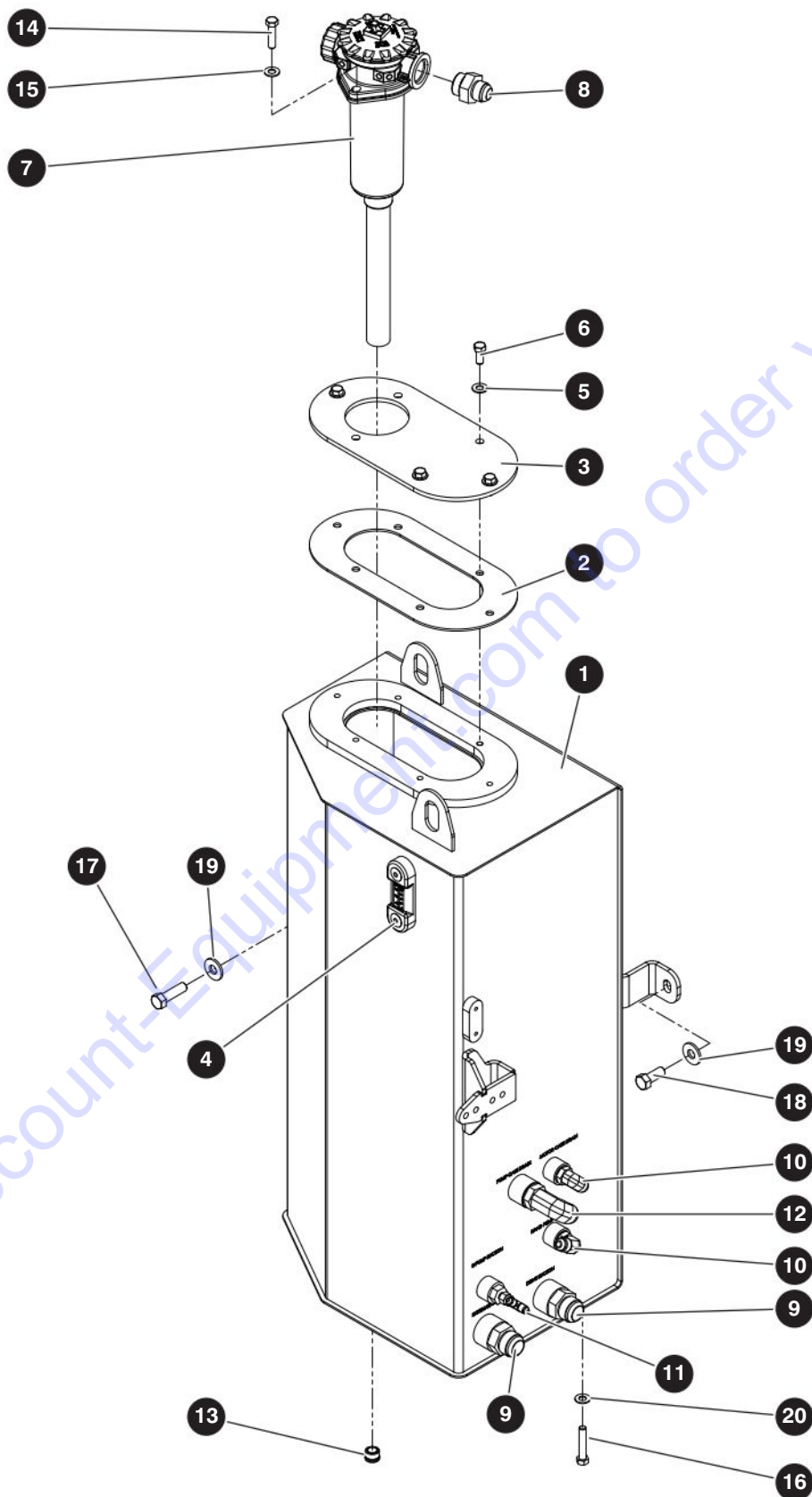

M162287AC

238271AAA

## 4.12 Hydraulic Tank

Index No.	Skyjack Part No.	Qty.	Description
-	162287	1	HYDRAULIC TANK
-	209553	1	• HYDRAULIC TANK ASSEMBLY with fittings
-	162322	1	• • HYDRAULIC TANK ASSEMBLY
1	162323	1	• • • TANK WELDMENT, Hydraulic
2	152393	1	• • • GASKET, Hydraulic tank
3	152392	1	• • • COVER, Hydraulic tank
4	103236	1	• • • INDICATOR, Level
5	103472	4	• • • WASHER, Flat hardened (3/8")
6	300437	4	• • • BOLT, Hex head (3/8"-16 x 0.875" Grade 5)
7	161934	1	• • FILTER ASSEMBLY, Return
	161949	1	• • • ELEMENT, Return filter
	168869	1	• • • ELEMENT, Breather
	168870	1	• • • LID, Return filter
	168871	1	• • • CAP, Air element
8	702122	1	• • FITTING, Straight (12 JICM - 16 ORBM)
9	138667	2	• • FITTING, Straight (16 JICM - 16 ORBM)
10	114583	2	• • FITTING, Elbow 90° (08 JICM - 08 ORBM)
11	103070	1	• • FITTING, Straight (06 JICM - 08 ORBM)
12	139207	1	• • FITTING, Elbow 90° long (12 JICM - 12 ORBM)
13	143980	1	• • FITTING, Plug - magnetic (08 ORBM)
14	103870	2	• • BOLT, Hex head (3/8"-16 x 1 1/2" Grade 5)
15	103472	2	• • WASHER, Flat (3/8")
16	103596	2	• BOLT, Hex head (3/8"-16 x 2" Grade 5)
17	103907	1	• BOLT, Hex head (1/2"-13 x 1-1/2" Grade 8)
18	103909	1	• BOLT, Hex head (1/2"-13 x 1-1/4" Grade 8)
19	104379	2	• WASHER, Flat (1/2" hard)
20	103472	2	• WASHER, Flat (3/8")

## 4.13 High Pressure Filter

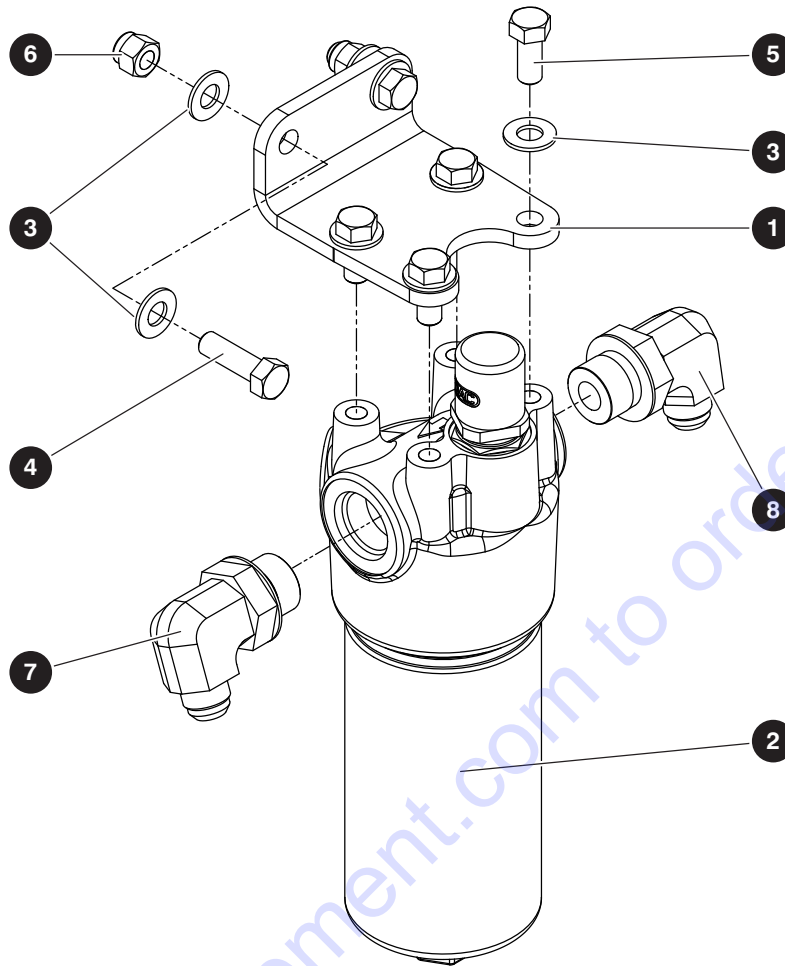

M162288AB

Index No.	Skyjack Part No.	Qty.	Description
-	162288	1	HIGH PRESSURE FILTER ASSEMBLY
1	162327	1	• BRACKET, High pressure filter
2	161932	1	• FILTER ASSEMBLY, High pressure
	161947	1	• • ELEMENT, High pressure filter
	169246	1	• • PLUG, Indicator with seals
	204202	1	• • O-RING
	204203	1	• • O-RING, Backup
3	103472	8	• WASHER, Flat (3/8")
4	101297	2	• BOLT, Hex head (3/8"-16 x 1.25" Grade 5)
5	300437	4	• BOLT, Hex head (3/8"-16 x 0.875" Grade 5)
6	104606	2	• NUT, Hex head nylon lock (3/8"-16 Grade 5)
7	112366	1	FITTING, Elbow 90° (08 JICM - 12 ORBM) <i>(no oil cooler option)</i>
8	138981	1	FITTING, Elbow 90° (10 JICM - 12 ORBM) <i>(no oil cooler option)</i>

## 4.14 Auxiliary Pump

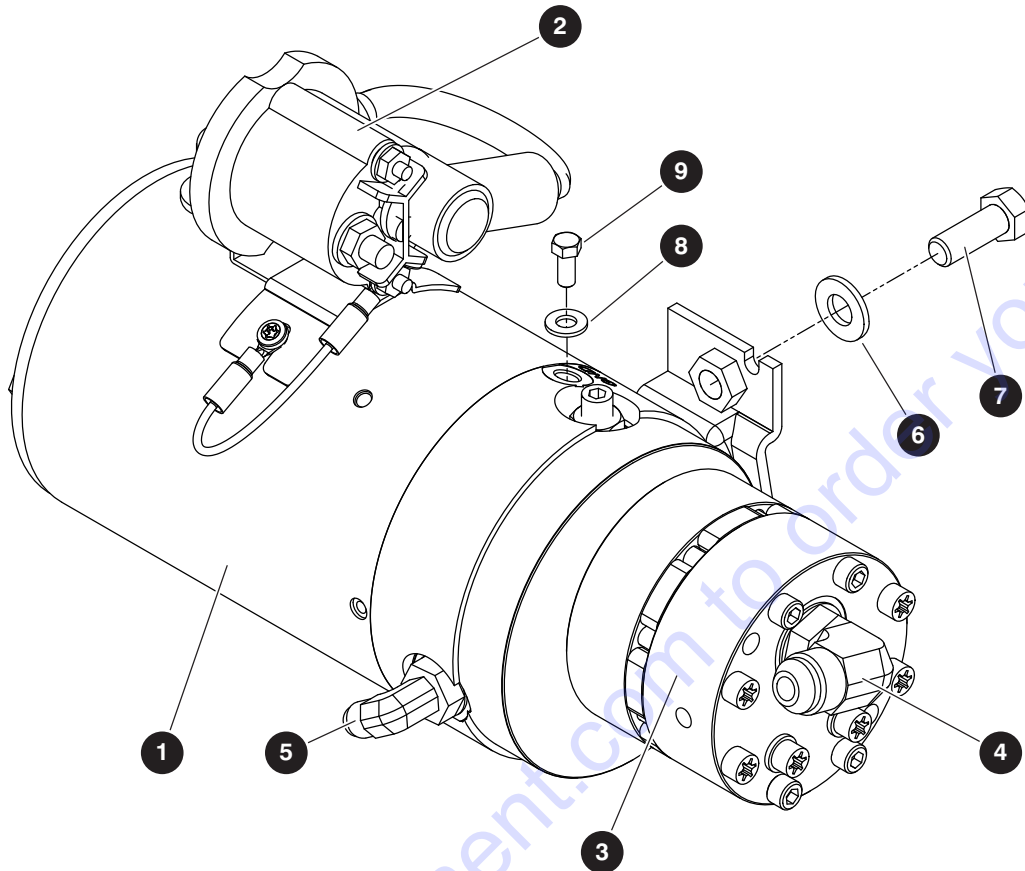

M167489AC

Index No.	Skyjack Part No.	Qty.	Description
-	167489	1	AUXILIARY PUMP
-	220500	1	• AUXILIARY PUMP WITH FITTINGS
-	160923	1	• • PUMP, Auxiliary
1	168897	1	• • • MOTOR
2	168898	1	• • • CONTACTOR
3	169244	1	• • • PUMP
4	114583	1	• • FITTING, Elbow, 90° (08 ORBM - 08 JICM)
5	129127	1	• • FITTING, Elbow, 90° (04 JICM - 06 ORBM)
6	125959	2	• WASHER, Flat hardened (0.375")
7	103473	2	• BOLT, Hex head (0.375"-16 x 1.00" Grade 5)
8	103404	1	• WASHER, Lock (0.312")
9	148331	1	• BOLT, Hex head (0.312"-18 x 0.625" Grade 5)

## 4.15 Battery

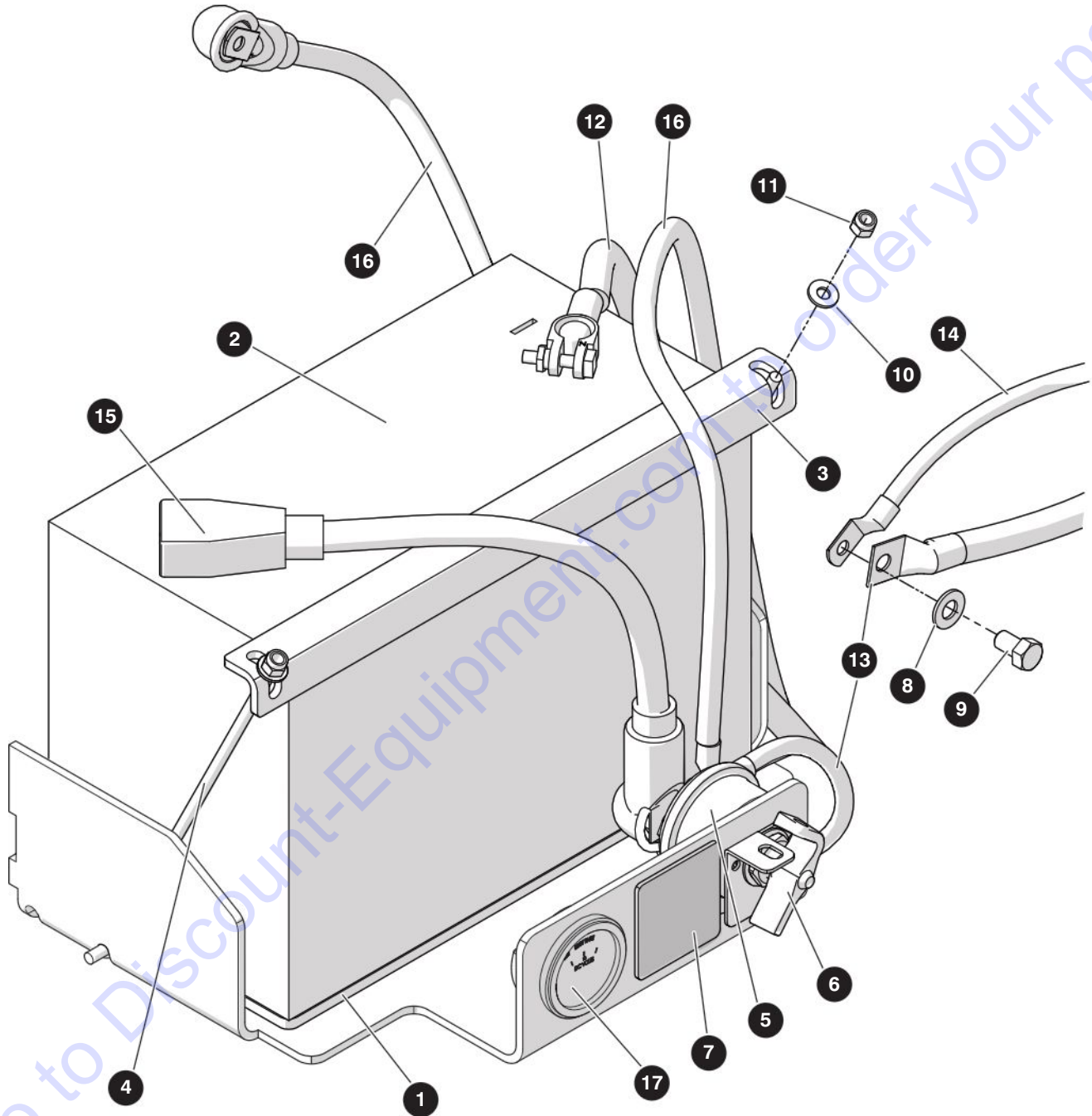

M238395AB

238271AAA

SJ45 AJ+



## 4.15 Battery

Index No.	Skyjack Part No.	Qty.	Description
-	238395	1	BATTERY ASSEMBLY
1	157464	1	• PAD, Battery
2	144676	1	• BATTERY (12V, 950 CCA)
3	150959	1	• BRACKET, Battery retainer
4	128572	1	• HOLD DOWN, Battery (pair)
5	119725	1	• SWITCH, Main lockout
6	108714	1	• MOUNT, Lock out switch
7	119674	1	• LABEL, Battery Disconnect
8	103472	1	• WASHER, Flat (3/8")
9	138464	1	• BOLT, Hex head (3/8"-16 x 0.650" Grade 5)
10	103995	2	• WASHER, Flat (1/4")
11	115649	2	• NUT, Lock (1/4"-20 gr 5)
12	238430	1	• CABLE, Weld (#2/0 3/8" x 33 x 3/8") (00,00)
13	238393	1	• CABLE, Weld (1GA 3/8" x 102 x 5/16") (103,103)
14	238394	1	• CABLE, Weld (1GA 3/8" x 80 x 5/16") (00,00)
15	138700	1	• CABLE, Battery (post + to disc)
	139032	1	• • BOOT, Battery post - red
	139105	1	• • BOOT, Terminal - red
16	138704	1	• CABLE, Weld (1GA 5/16" x 86" x 5/16") (03,03)
	139106	1	• • BOOT, Terminal - red
-	170482	1	CHARGE INDICATOR ASSEMBLY
17	152323	1	• INDICATOR, Charge
18	152344	1	• WIRE ASSEMBLY, Charge indicator (00) (not shown)
19	152345	1	• WIRE ASSEMBLY, Charge indicator (03) (not shown)

## 4.16 Base Control Box

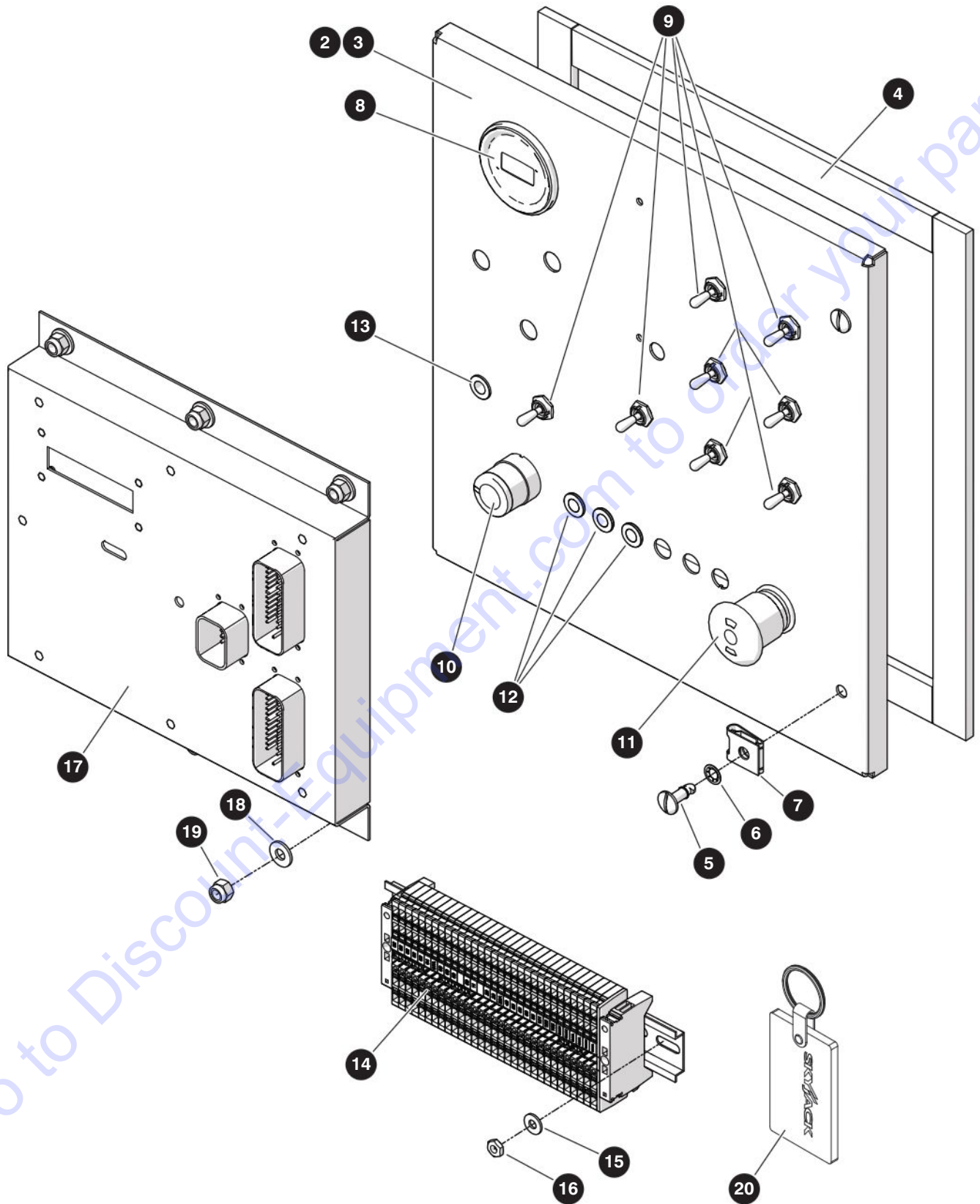

M238424AB-1

238271AAA

SJ45 AJ+

## 4.16 Base Control Box

Index No.	Skyjack Part No.	Qty.	Description
-	238424	1	BASE CONTROL BOX
-	238408	1	• CONTROL BOX
1	238407	1	• • BODY, Control box
2	218243	1	• • DOOR, Control box
3	149281	1	• • HINGE, Continuous
4	149282	1	• • WEATHER STRIP
5	149437	2	• • BOLT - 1/4 turn
6	149320	2	• • RETAINER - 1/4 turn
7	149321	2	• • RECEPTACLE - 1/4 turn
8	195940	1	• HOUR METER
9	102853	8	• SWITCH, Toggle
10	218354	1	• SWITCH, Key
	147056	1	• • LATCH, Mounting
	149605	1	• • HEAD, Selector switch - keyed
	166141	1	• • BLOCK, Contact, NO (black plunger)
	166142	1	• • BLOCK, Contact, NO (yellow plunger)
	147053	1	• • BLOCK, NC Contact
11	144652	1	• SWITCH, Emergency stop
	147056	1	• • LATCH, Mounting
	147053	1	• • BLOCK, NC Contact
	147229	1	• • SWITCH, LED block
	147051	1	• • SWITCH HEAD, Emergency stop
12	213307	4	• LIGHT, LED amber - 12V
13	213308	1	• LIGHT, LED red - 12V
14	(Ref.)	1	• TERMINAL STRIP, Base (For components, refer to 4.17 Base Terminal Strip)
15	104694	2	• WASHER, Flat (#10)
16	104003	2	• NUT, Hex (10-32)
17	218381	1	• MODULE, Master
	218277	1	• • SERVICE TOOL
	218276	1	• • • HARNESS, SMB1 to peak
	218278	1	• • • ADAPTER, PCAN-USB
18	103995	6	• WASHER, Flat (1/4")
19	115649	6	• NUT, Hex lock (1/4"-20 Gr 5, nylon)
20	114710	1	KEYRING

## 4.16 Base Control Box

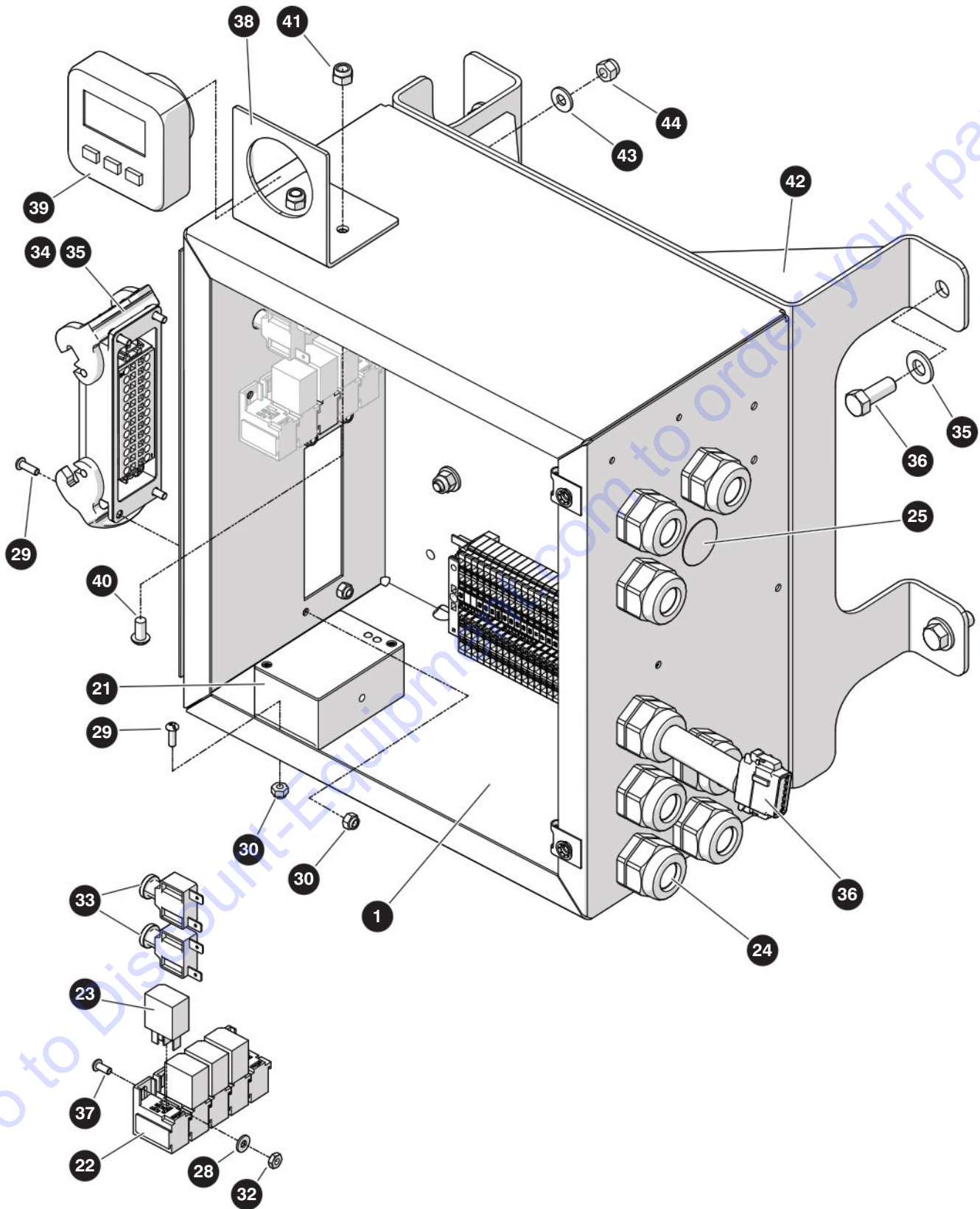

M238424AB-2

238271AAA

# PARTS FINDER

**Search Website  
by Part Number**



**Search Manual  
Library For Parts  
Manual & Lookup Part  
Numbers – Purchase  
or Request Quote**

**Search Manuals**

Enter your information to help us find the right parts manual for your machine.

\* Brand:

\* Model:

\* Serial:

\* Part Number:

SEARCH

**Can't Find Part or  
Manual? Request Help  
by Manufacturer,  
Model & Description**

**Parts Order Form**

Please fill in the following information to help us find the right part for your machine.

MANUFACTURER:

MODEL:

DESCRIPTION:

DATE:

NAME:

PHONE:

EMAIL:

ADDRESS:

CITY:

STATE:

ZIP:

PHONE:

EMAIL:

REQUEST QUOTE

Discount-Equipment.com is your online resource for quality parts & equipment.

Florida: **561-964-4949** Outside Florida TOLL FREE: **877-690-3101**

**Need parts?**

Click on this link: <http://www.discount-equipment.com/category/5443-parts/> and choose one of the options to help get the right parts and equipment you are looking for. Please have the machine model and serial number available in order to help us get you the correct parts. If you don't find the part on the website or on one of the online manuals, please fill out the request form and one of our experienced staff members will get back to you with a quote for the right part that your machine needs.

We sell worldwide for the brands: Genie, Terex, JLG, MultiQuip, Mikasa, Essick, Whiteman, Mayco, Toro Stone, Diamond Products, Generac Magnum, Airman, Haulotte, Barreto, Power Blanket, Nifty Lift, Atlas Copco, Chicago Pneumatic, Allmand, Miller Curber, Skyjack, Lull, Skytrak, Tsurumi, Husquvarna Target, Stow, Wacker, Sakai, Mi-T-M, Sullair, Basic, Dynapac, MBW, Weber, Bartell, Bennar Newman, Haulotte, Ditch Runner, Menegotti, Morrison, Contec, Buddy, Crown, Edco, Wyco, Bomag, Laymor, EZ Trench, Bil-Jax, F.S. Curtis, Gehl Pavers, Heli, Honda, ICS/PowerGrit, IHI, Partner, Imer, Clipper, MMD, Koshin, Rice, CH&E, General Equipment, Amida, Coleman, NAC, Gradall, Square Shooter, Kent, Stanley, Tamco, Toku, Hatz, Kohler, Robin, Wisconsin, Northrock, Oztec, Toker TK, Rol-Air, APT, Wylie, Ingersoll Rand / Doosan, Innovatech, Con X, Ammann, Mecalac, Makinex, Smith Surface Prep, Small Line, Wanco, Yanmar

## 4.16 Base Control Box

Index No.	Skyjack Part No.	Qty.	Description
21	149426	1	• ANGLE TRANSDUCER - DUAL AXIS
22	218997	5	• SOCKET, Micro relay
23	931298	4	• RELAY
24	116266	8	• CONNECTOR, Liquid tight (Heyco)
25	131938	1	• PLUG, Hole (1-1/8")
26	103056	1	• BEEPER (7.5 - 16 VDC)
27	146652	1	• HORN. (12V)
28	103991	2	• WASHER, Flat (#8)
29	103957	6	• SCREW, Round head machine (8-32 x 1/2")
30	138765	8	• NUT, Lock (8-32 Grade5, zinc-nylon)
31	126499	2	• SCREW, Round head machine (8-32 x 7/8")
32	103986	2	• NUT, Hex (8-32)
33	117325	2	• BREAKER, Circuit (15 AMP)
34	138751	1	• HOUSING - OPEN BOT. 24 POLE DBL. LEVER
35	138756	1	• SOCKET, 24 POLE SPRING 16A
36	221144	1	• HARNESS, Elevate telematics bypass
37	204325	2	• SCREW, Round head machine (8-32 x 3/8")
38	238420	1	• BRACKET, Engine display
39	166739	1	• DISPAY, Engine parameter
40	300060	2	• BOLT, Button head cap (1/4"-20 x 1/2")
41	115649	2	• NUT, Lock (1/4"-20, gr 5)
42	149056	1	BRACKET, Control box mount
43	103995	4	WASHER, Flat (1/4")
44	115649	4	NUT, Lock (1/4"-20, gr 5)
45	125959	3	WASHER, Flat (3/8")
46	103473	3	BOLT, Hex head (3/8"-16 x 1, gr 5)

## 4.17 Base Terminal Strip

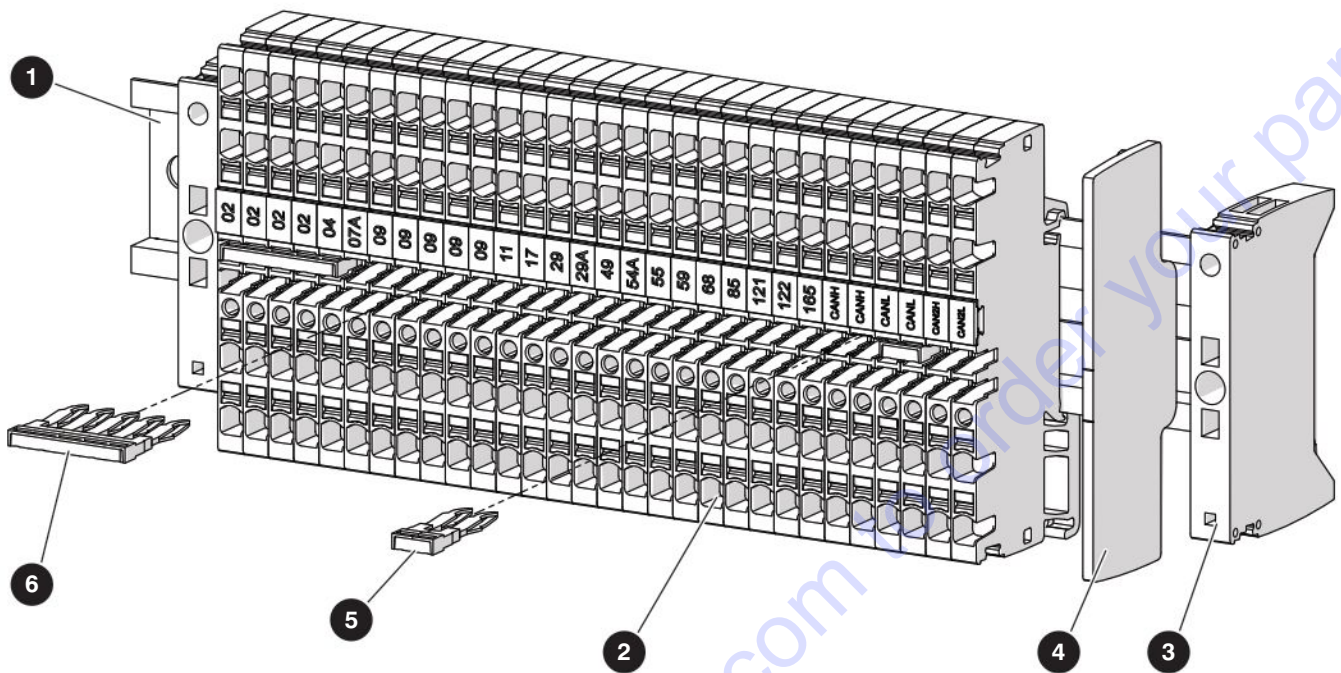

M218498AD

Index No.	Skyjack Part No.	Qty.	Description
-	218498	1	BASE TERMINAL STRIP
1	233337	224 mm	• RAIL
2	233338	32	• BLOCK, Terminal
3	233341	2	• PLATE, End
4	233342	1	• PLATE, Separator
5	233343	2	• JUMPER, 2-pin
6	233345	2	• JUMPER, 5-pin

## 4.18 Grease Line

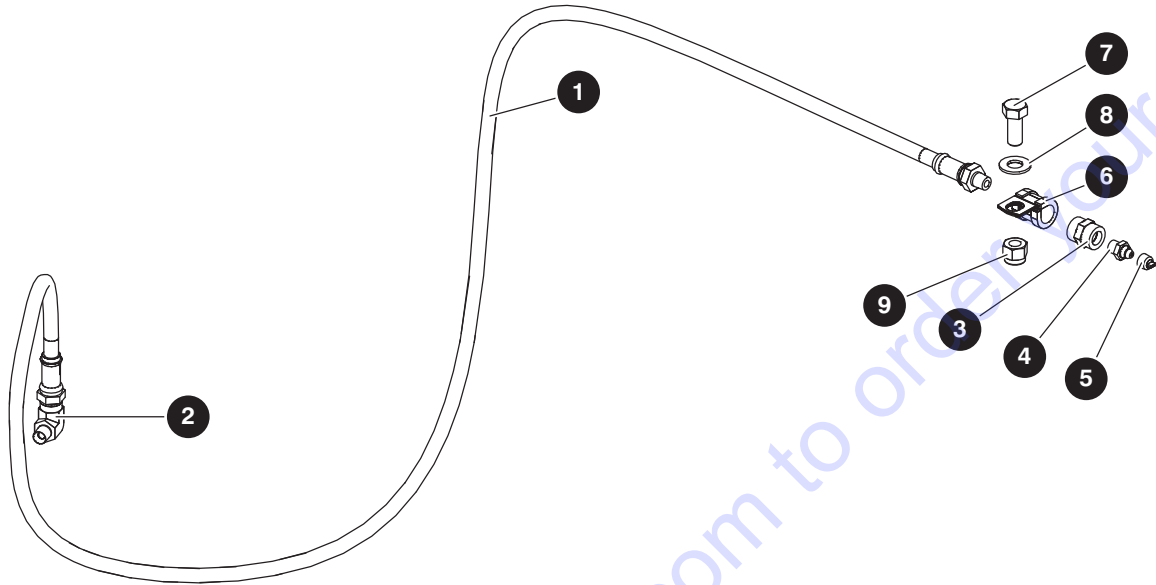

M148613AB

Index No.	Skyjack Part No.	Qty.	Description
-	148613	1	GREASE LINE HOSE ASSEMBLY
1	139090	1	• LINE, Grease
2	139094	1	• FITTING, Elbow 90° (1/8 NPTM - 1/8 NPTF)
3	139095	1	• FITTING, Straight (1/8 NPTF - 1/8 NPTF)
4	102027	1	• FITTING, Straight grease (1/8 NPT)
5	132565	1	• CAP
6	144129	1	• CLIP, Single
7	300437	1	• BOLT, Hex head (3/8"-16 x 7/8", Grade 5)
8	103472	1	• WASHER, Flat (3/8")
9	104606	1	• NUT, Hex lock (3/8"-16 Grade 5, nylon)



# Section 5 – Base

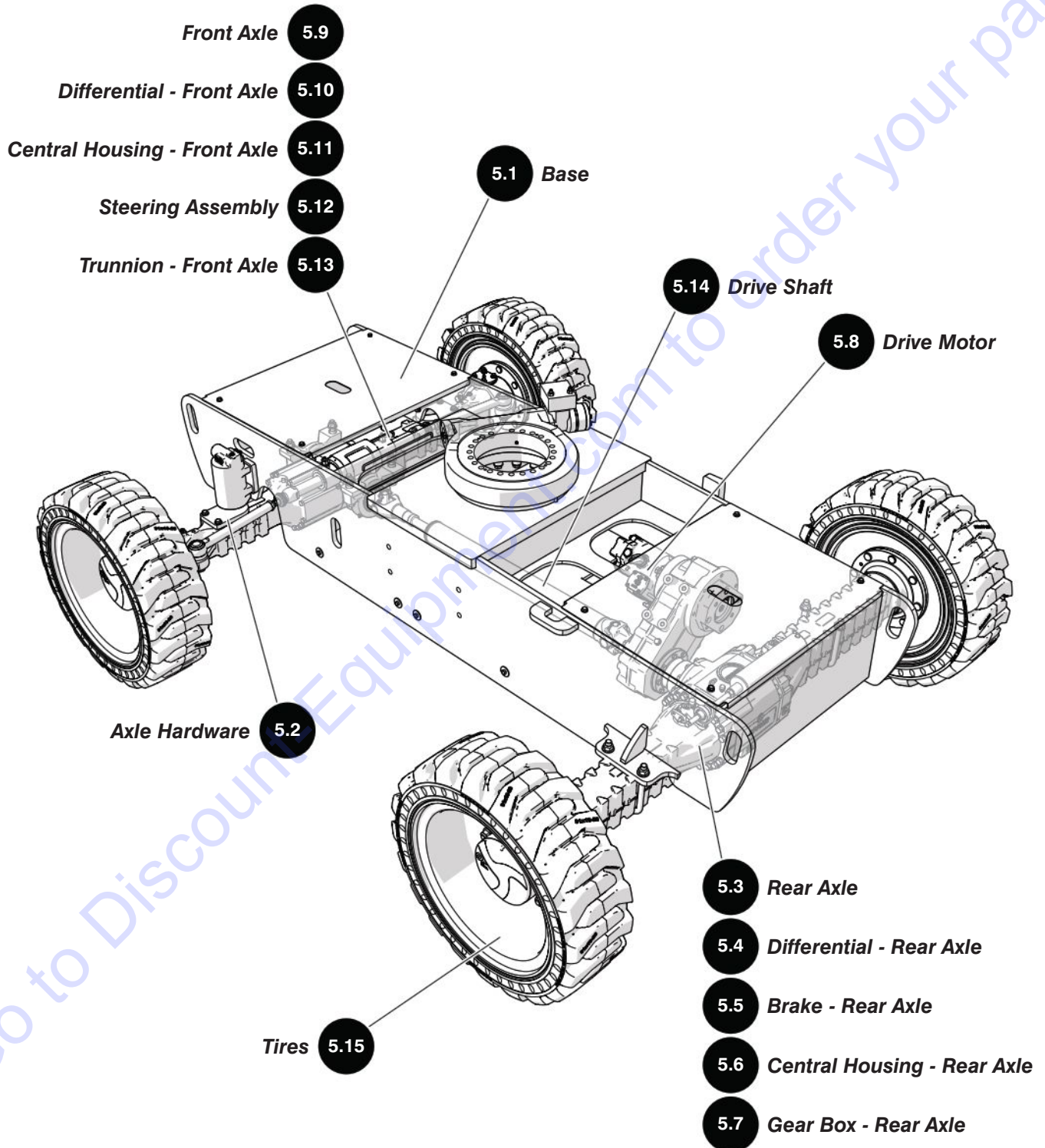

## 5.1 Base

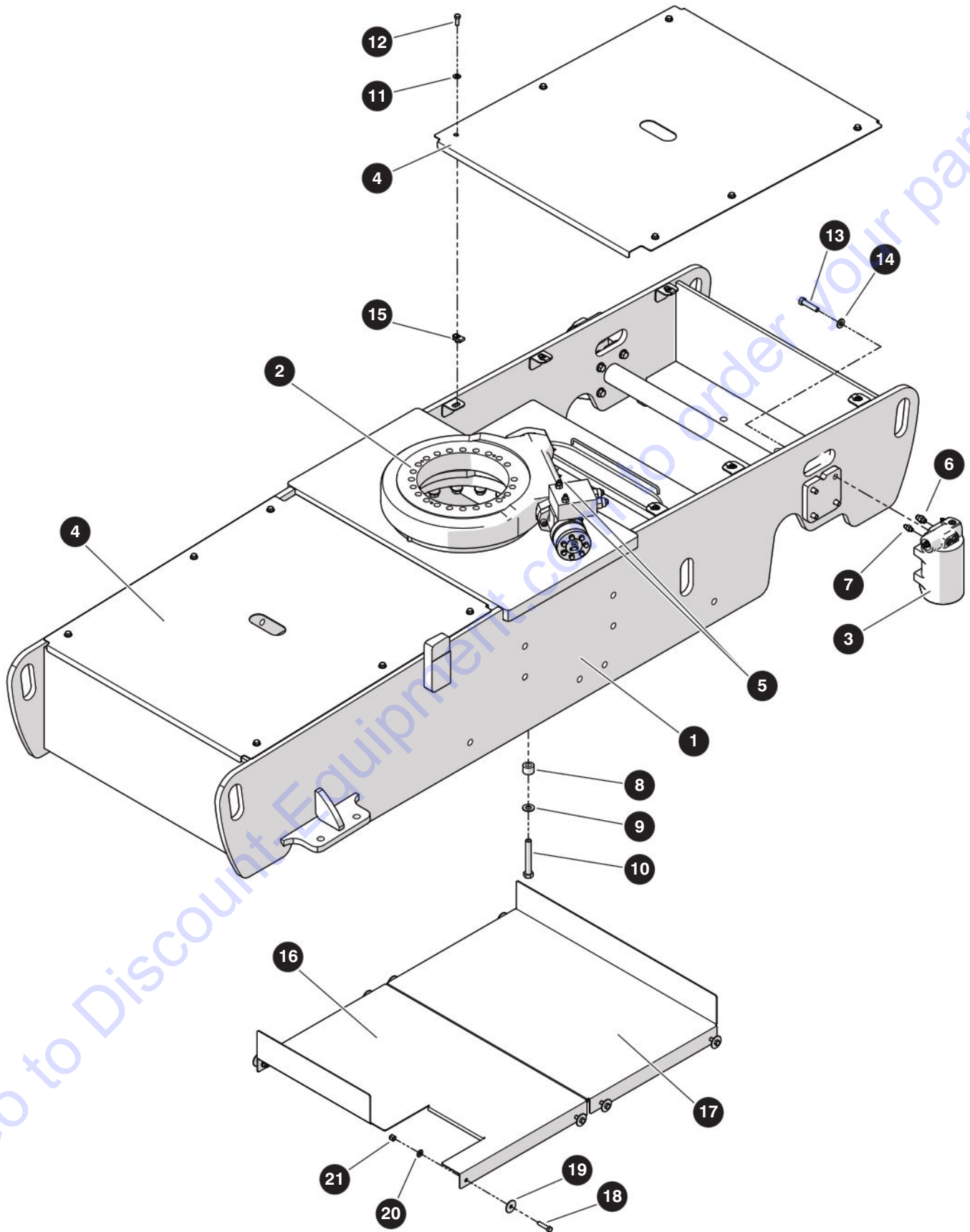

M231439AB

238271AAA

104

SJ45 AJ+

SKYJACK

## 5.1 Base

Index No.	Skyjack Part No.	Qty.	Description
-	231439	1	CHASSIS
1	210405	1	• WELDMENT, Base
2	216673	1	• GEAR, Worm
	213546	1	• • MOTOR, Hydraulic - worm gear
	213545	1	• • SEAL KIT, Worm gear
	207357	1	• • SHIM KIT, Worm gear
3	(Ref.)	2	• AXLE LOCK CYLINDER ASSEMBLY (For components, refer to 3.8 Axle Lock Cylinder)
4	161172	2	• COVER, Chassis
5	701956	2	• FITTING, Straight (04 JICM - 08 ORBM)
6	103069	2	• FITTING, Straight (06 JICM - 06 ORBM)
7	126128	2	• FITTING, Straight (04 JICM - 04 ORBM)
8	149024	18	• SPACER
9	700782	18	• WASHER, Flat hardened (5/8")
10	701762	18	• BOLT, Hex head (5/8"-11 x 4.5", Grade 8)
11	103472	12	• WASHER, Flat (3/8")
12	103473	12	• BOLT, Hex head (3/8"-16 x 1.00", Grade 5)
13	207654	8	• BOLT, Hex head patch (1/2"-13 x 2.25", Grade 8)
14	104379	8	• WASHER, Flat hardened (1/2")
15	159294	8	• NUT, Speed clip (3/8"-16)
-	210408	1	HOSE TRAY
16	208638	1	• PLATE, Botton rear
17	208639	1	• PLATE, Bottom front
18	208945	8	• BOLT, Hex head (0.375"-16 x 1.625 gr 5)
19	127067	8	• WASHER, Flat (0.375" BB)
20	103472	8	• WASHER, Flat (0.375")
21	104606	8	• NUT, Lock (0.375"-16 gr 5 nylon)

## 5.2 Axle Hardware

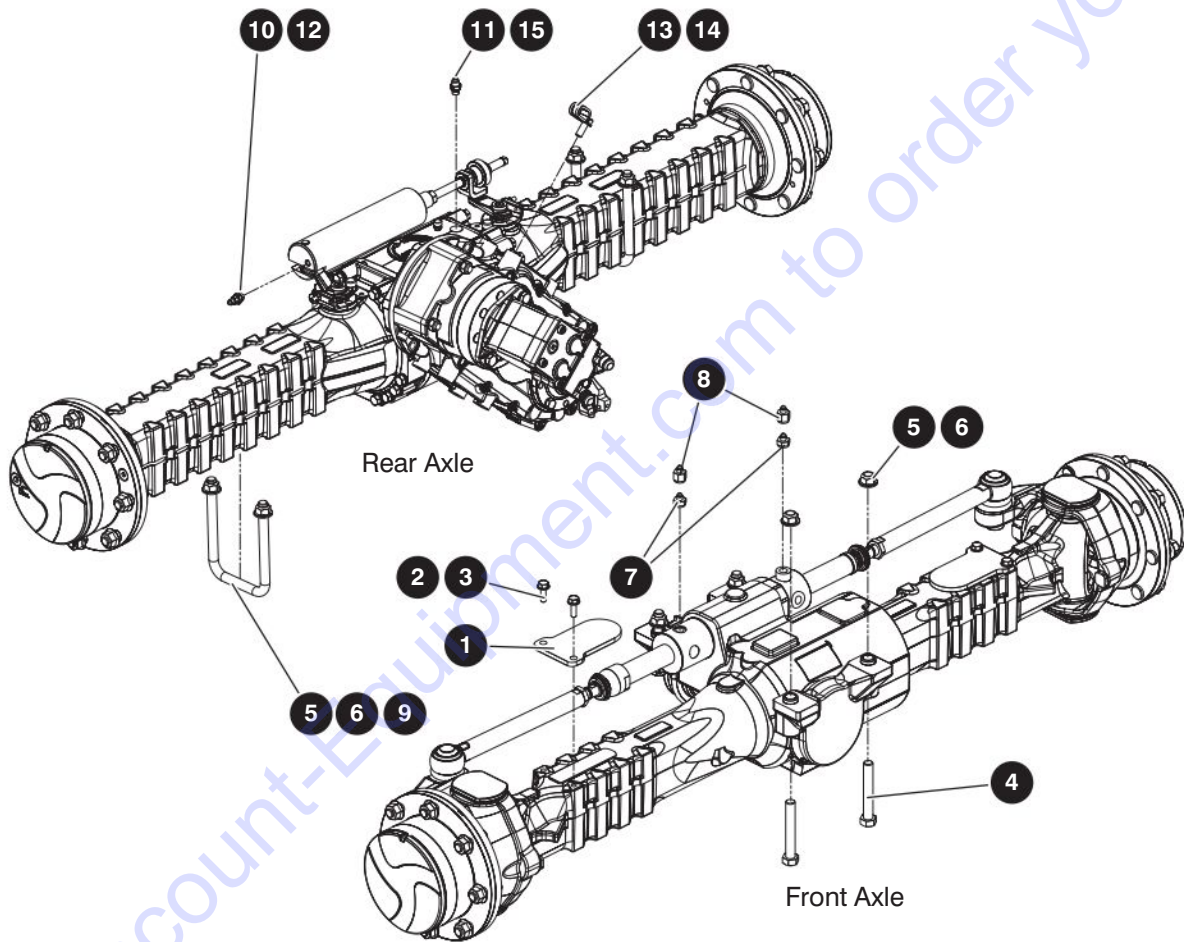

M148602AC\_M163573AA

238271AAA

SJ45 AJ+

## 5.2 Axle Hardware

Index No.	Skyjack Part No.	Qty.	Description
1	231407	2	PLATE, Wear pad
2	149419	4	BOLT, Hex head (M12 x 1.75 x 25mm, Grade 8.8)
3	104379	4	WASHER, Flat hardened (1/2")
4	146773	4	BOLT, Hex head (3/4"-10 x 5", Grade 8)
5	702194	8	WASHER, Flat hardened (3/4")
6	700575	8	NUT, Torque lock (3/4"-10, Grade C)
7	152304	2	FITTING, Straight (08 JICM - M18 DIN 3852-1)
8	706812	2	FITTING, Straight (08 JICF - 04 JICM)
9	148866	2	U-BOLT, Axle mount
10	144128	1	FITTING, 90° (04 JICM - 04 BSPPM)
11	149181	1	FITTING, Straight (06 JICM - M14 ISO6149)
12	139126	1	SEAL, British bonded (04BSPPM)
13	152333	1	CLAMP, Tube (5/8" cus double 17/32 hole)
14	138734	1	BOLT, Hex head (M14 x 2 x 30 mm, grade 8.8)
17	702875	1	FITTING, Straight (04JICM-04JICFS)

## 5.3 Rear Axle

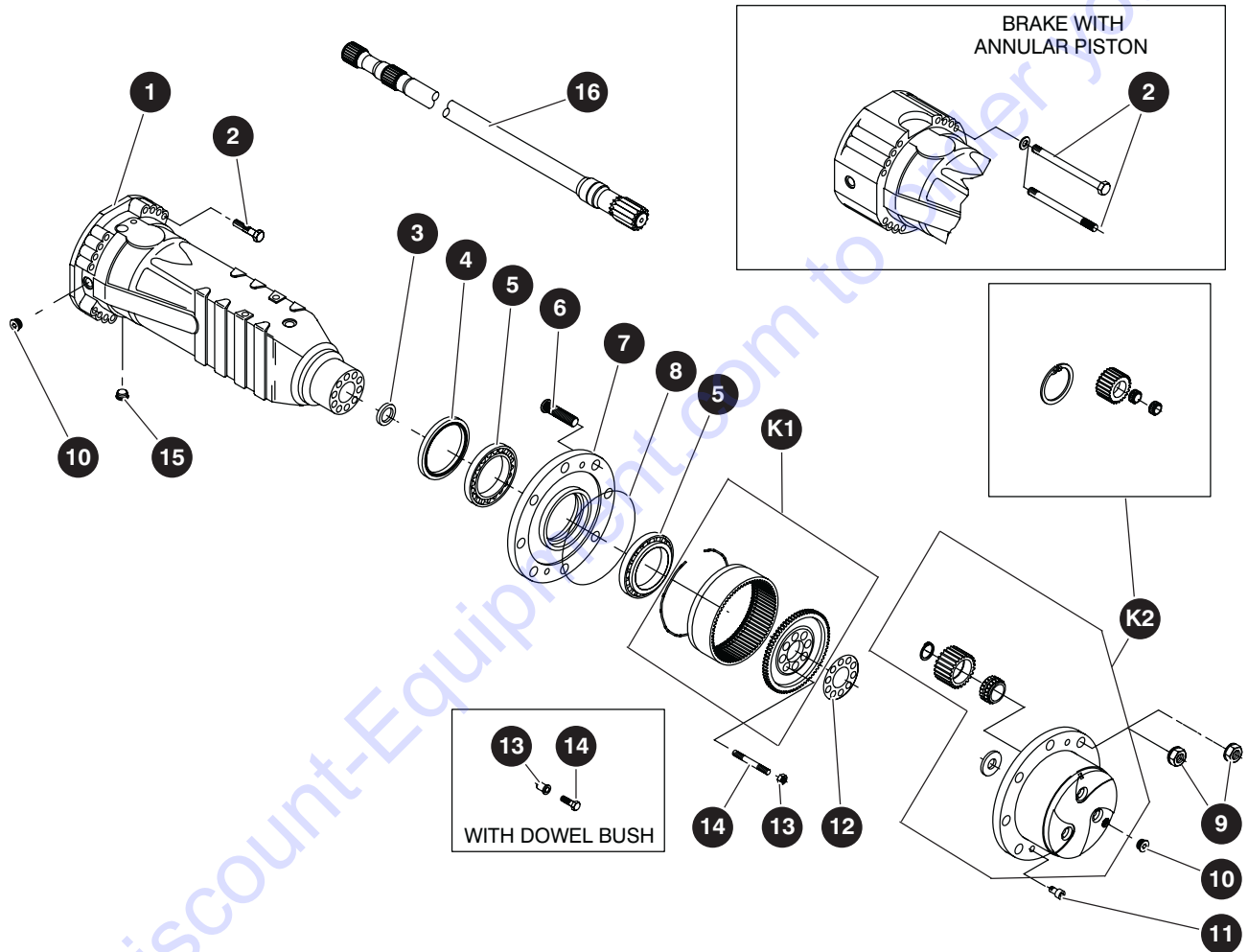

## 5.3 Rear Axle

Index No.	Skyjack Part No.	Qty.	Description
-	148916	1	REAR AXLE ASSEMBLY (with gear box)
1	141078	2	• CASE, Axle
2	141079	32	• BOLT
3	141082	2	• SEAL
4	141018	2	• SEAL
5	141019	4	• BEARING
6	141021	16	• STUD, Wheel
7	141020	2	• HUB, Wheel
8	140970	2	• O-RING
9	154590	16	• NUT
10	140969	4	• PLUG
11	141033	4	• BOLT, Countersunk
12	141081	2	• PLATE, Locking
13	141027	16	• NUT
14	141026	16	• STUD
15	140968	2	• PLUG, Magnet
16	141080	2	• SHAFT, Half
17	(Ref.)	2	• DIFFERENTIAL ASSEMBLY (For components, refer to 5.4 Differential - Rear Axle)
18	(Ref.)	1	• BRAKES - REAR AXLE (For components, refer to 5.5 Brake - Rear Axle)
19	(Ref.)	1	• CENTRAL HOUSING ASSEMBLY (For components, refer to 5.6 Central Housing - Rear Axle)
<b>K1</b>	141042	2	KIT, Ring gear support
<b>K2</b>	141034	2	KIT, Planet gear carrier

# 5.4 Differential - Rear Axle

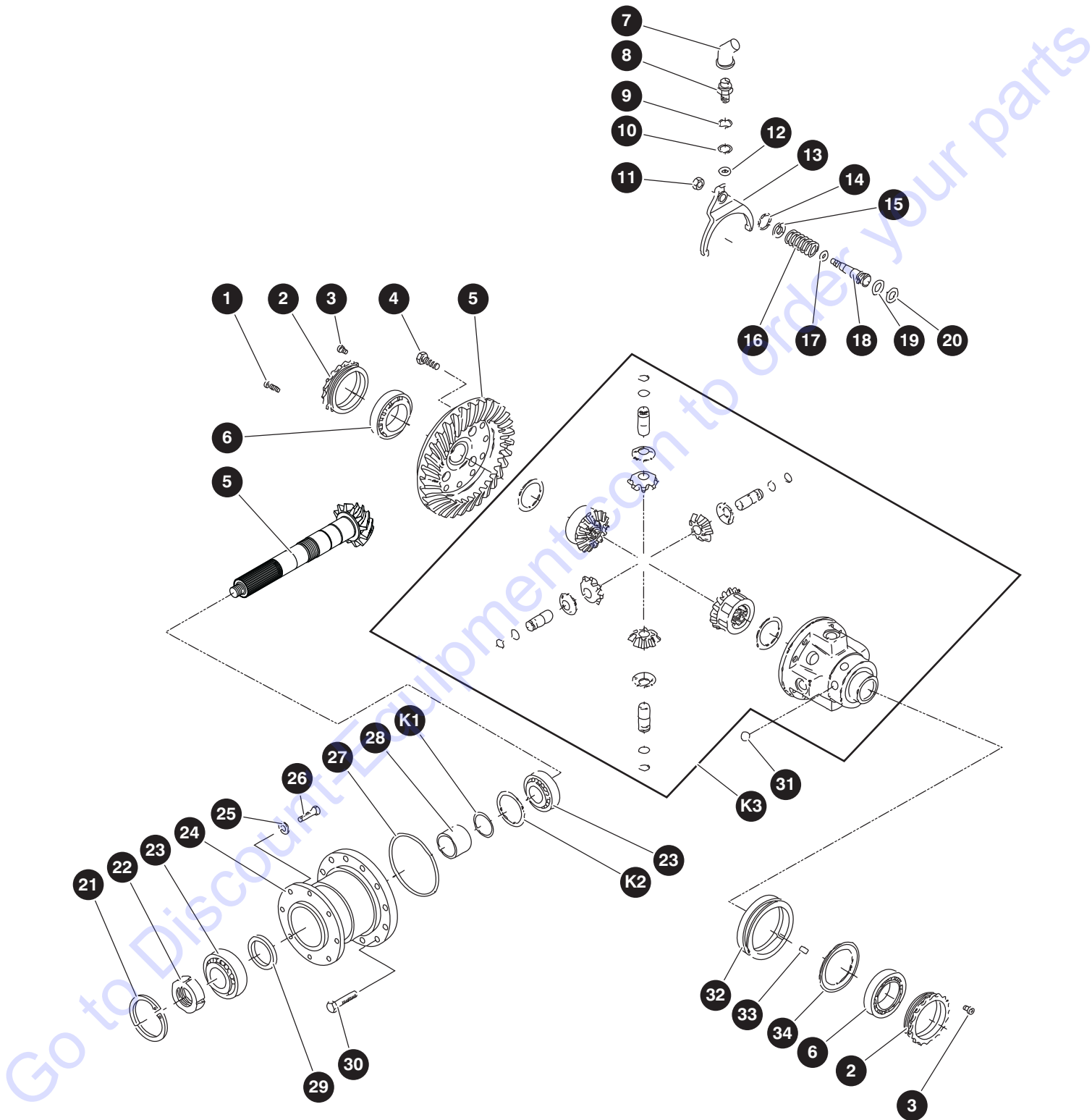

M148916AA\_D

238271AAA

SJ45 AJ+



## 5.4 Differential - Rear Axle

Index No.	Skyjack Part No.	Qty.	Description
1	140977	4	BOLT
2	141068	2	NUT, Ring
3	151768	2	BOLT
4	140993	12	BOLT
5	141065	1	GEAR SET, Bevel
6	140987	2	BEARING, Taper roller
7	154576	1	BOOT
8	154577	1	SWITCH, Security
9	154589	1	WASHER, Seal
10	154578	1	WASHER, Seal
11	154580	1	NUT
12	154579	1	O-RING
13	154588	1	SELECTOR FORK
14	154587	1	CIRCLIP
15	154586	1	PLUG
16	154585	1	SPRING
17	154571	1	CIRCLIP
18	154584	1	PISTON
19	154583	1	O-RING
20	154575	1	RING
21	140966	1	CIRCLIP
22	140980	1	RING NUT
23	140984	2	BEARING, Taper roller
24	141063	1	COVER
25	141075	8	WASHER, Spring
26	141076	8	BOLT, Hexagon
27	141064	1	O-RING
28	141062	1	SPACER
29	141074	1	SEAL
30	141072	12	BOLT, Hexagon
31	154574	6	BALL, Detent
32	154582	1	SELECTOR
33	154572	1	KEY
34	154581	1	SHEET
<b>K1</b>	140982	1	KIT, Shim
<b>K2</b>	140983	1	KIT, Shim
<b>K3</b>	154573	1	KIT, Differential position

## 5.5 Brake - Rear Axle

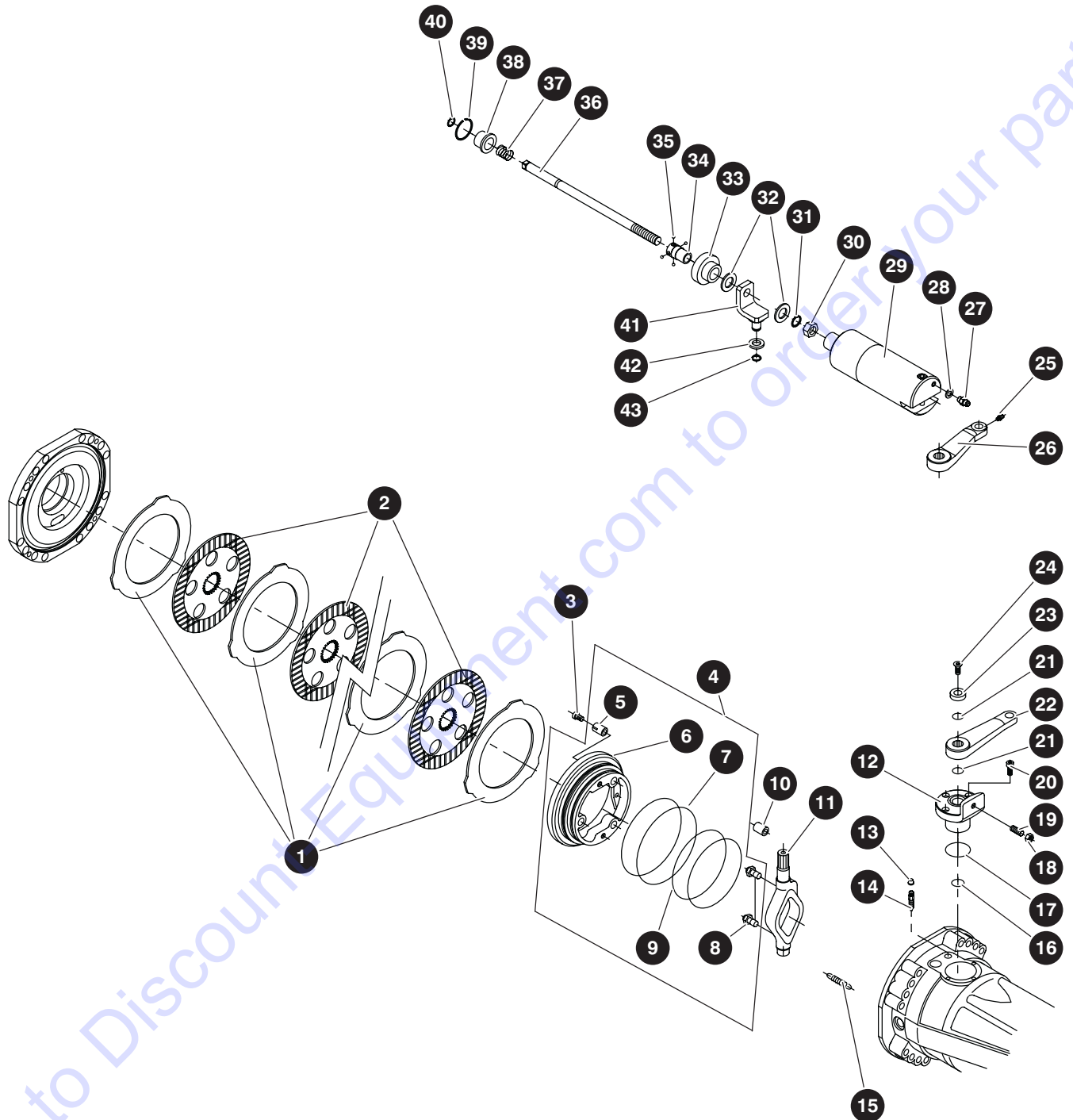

M141084AB

238271AAA

112

SJ45 AJ+

SKYJACK

## 5.5 Brake - Rear Axle

Index No.	Skyjack Part No.	Qty.	Description
1	141096	10	BRAKE DISC, Intermediate
2	141108	8	DISC, Brake
3	141097	6	BOLT, Adjusting
4	151757	1	PISTON <b>(Right)</b>
	151758	1	PISTON <b>(Left)</b>
5	141098	3	• SPRING
6	141109	1	• PISTON <b>(Right)</b>
	141099	1	• PISTON <b>(Left)</b>
7	141101	1	• O-RING
8	151759	2	• PUSHER
9	141107	1	• O-RING
10	141102	2	DOWEL
11	141085	1	LEVER <b>(Right)</b>
	141103	1	LEVER <b>(Left)</b>
12	141089	2	BUSHING, Reduction
13	141006	2	PLUG
14	141086	2	BOLT, Bleeding
15	141104	6	SPRING
16	141129	2	O-RING
17	141088	2	O-RING
18	141091	2	NUT
19	141090	2	BOLT
20	141087	6	BOLT
21	141092	2	O-RING
22	141093	1	LEVER
23	141094	2	WASHER
24	141095	2	BOLT, Countersunk
25	141112	1	FITTING, Grease
26	141110	1	LEVER
27	139126	1	SEAL, British bonded
28	149195	1	FITTING, Elbow 90° (04 JICM - 04 BSPPM)
29	141123	1	CYLINDER, Wheel
30	141122	1	NUT
31	141121	1	CIRCLIP
32	141113	2	WASHER
33	141119	1	BUSHING, Reduction
34	141124	1	BUSHING, Reduction
35	141118	4	BALL, Detend
36	141117	1	CAM, Brake
37	141116	1	SPRING
38	141115	1	BUSHING, Reduction

## 5.5 Brake - Rear Axle

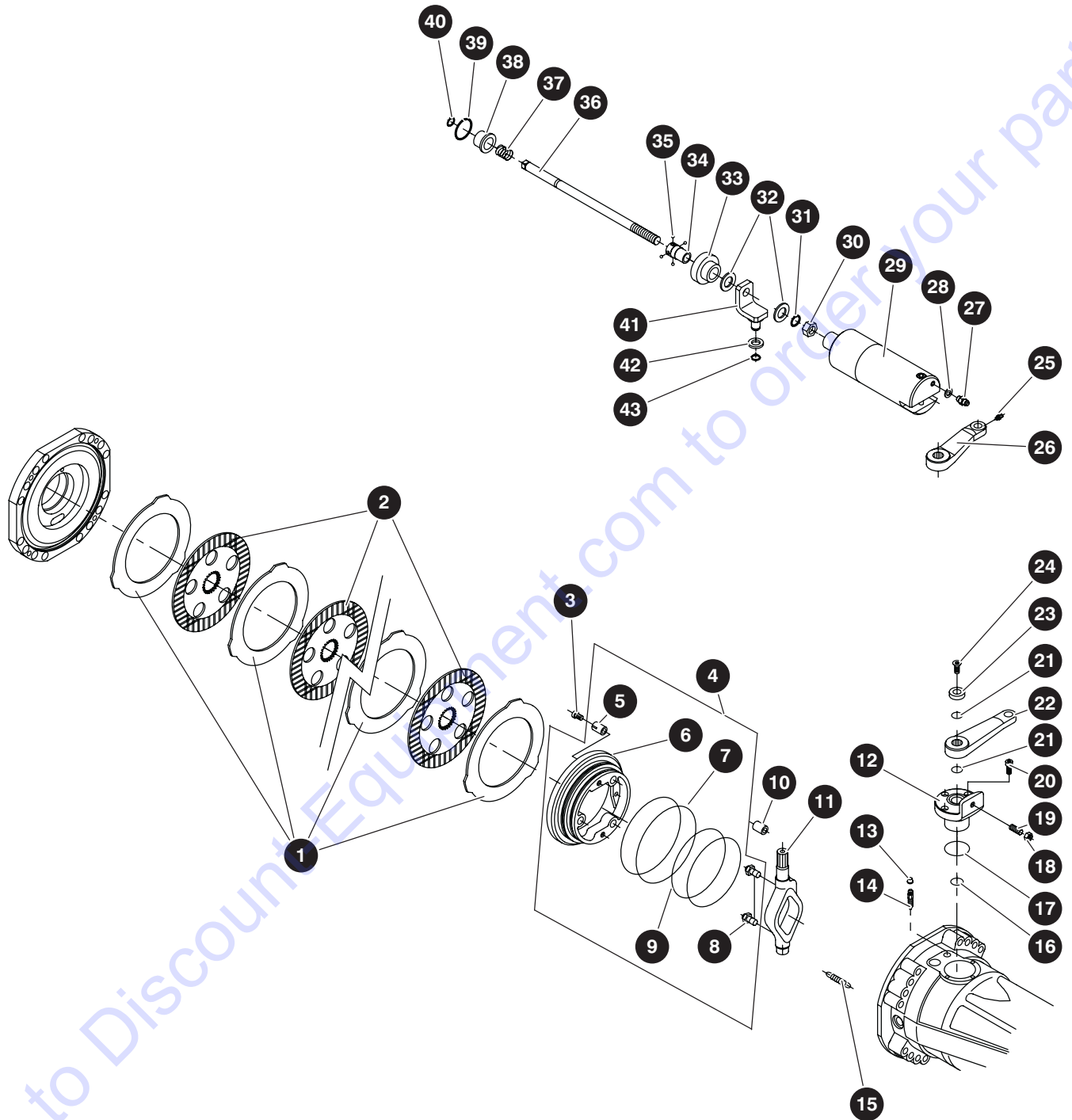

M141084AB

238271AAA

SJ45 AJ+

## 5.5 Brake - Rear Axle

Index No.	Skyjack Part No.	Qty.	Description
39	141114	1	RING, Snap
40	141111	1	CIRCLIP
41	141120	1	SUPPORT
42	141126	1	SPACER
43	141125	1	CIRCLIP
<b>K1</b>	408688	1	KIT, Seal (Brake cylinder) (Not Shown)

## 5.6 Central Housing - Rear Axle

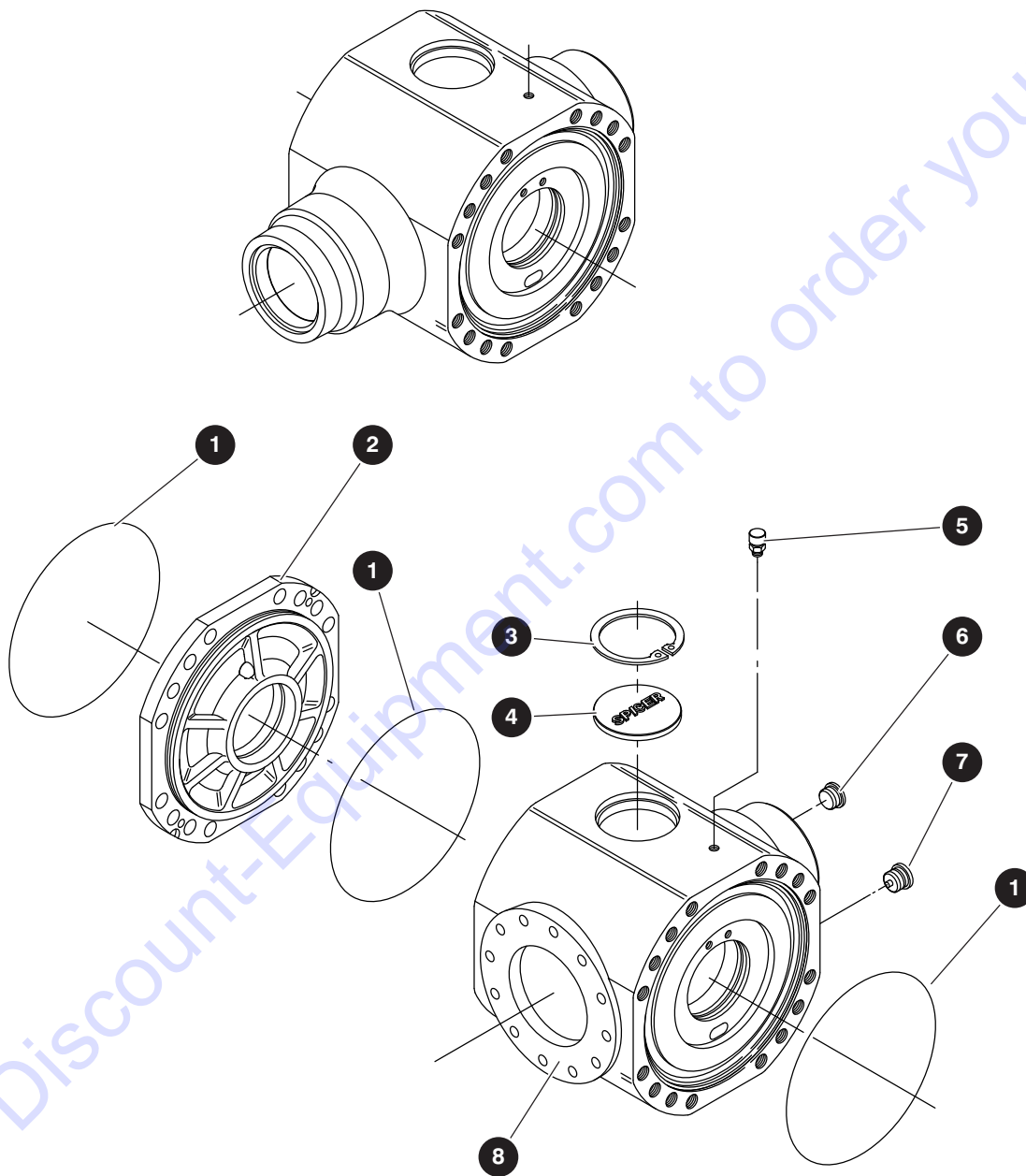

M141057AA\_2

238271AAA

SJ45 AJ+

## 5.6 Central Housing - Rear Axle

Index No.	Skyjack Part No.	Qty.	Description
-	154602	1	CENTRAL HOUSING - Rear Axle
1	140970	3	• O-RING
2	141054	1	• COVER, Intermediate
3	140966	1	• CIRCLIP
4	140967	1	• PLUG
5	141059	1	• VENT
6	140969	1	• PLUG
7	140968	1	• PLUG, Magnet
8	154570	1	• HOUSING

## 5.7 Gear Box - Rear Axle

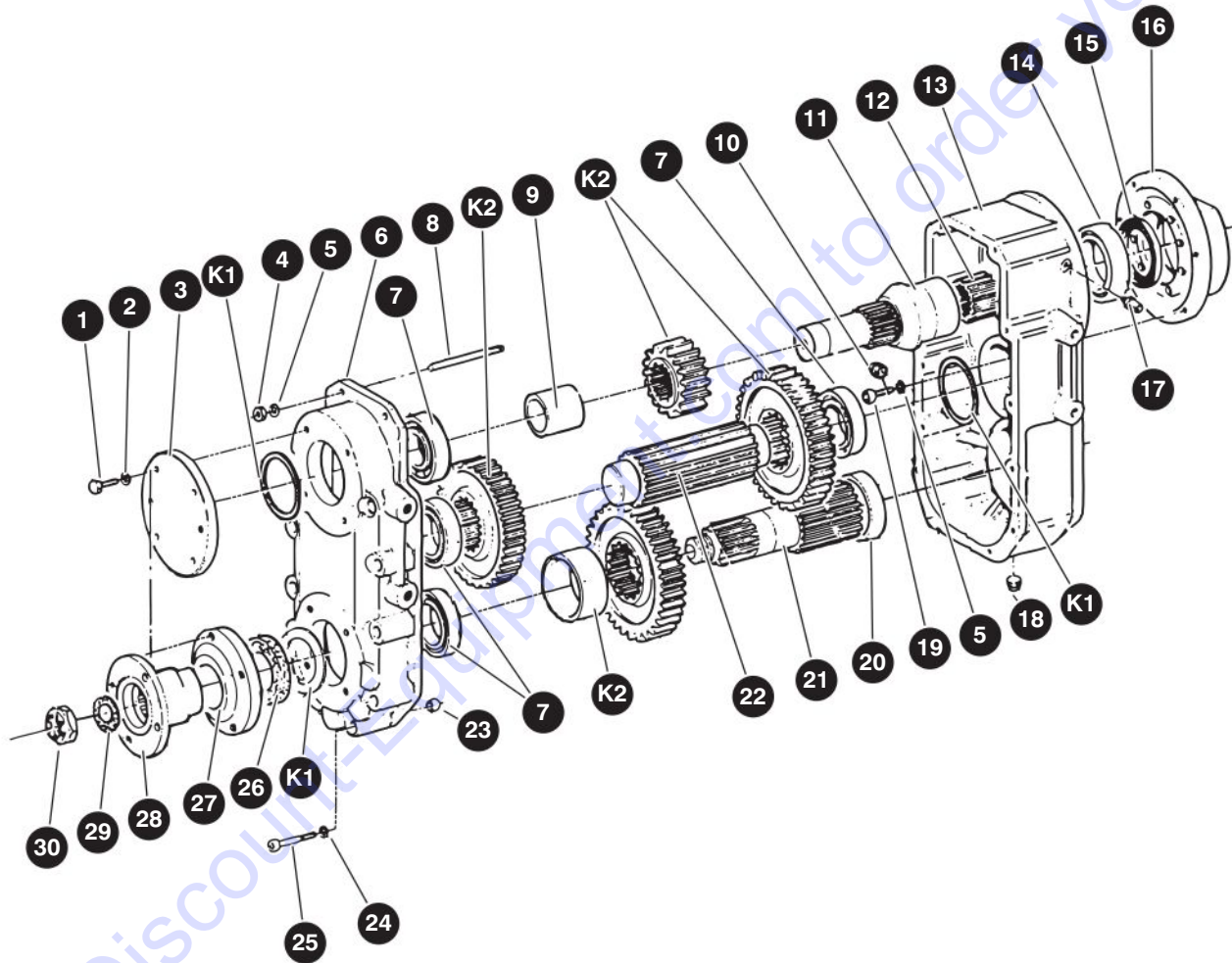



## 5.7 Gear Box - Rear Axle

Index No.	Skyjack Part No.	Qty.	Description
-	154591	1	BOX, Gear
1	141072	4	• BOLT, Hex
2	141373	4	• WASHER, Spring
3	154592	1	• COVER
4	141363	2	• NUT
5	141364	4	• WASHER, Spring
6	154593	1	• HOUSING
7	141137	3	• BEARING, Ball
8	141367	2	• STUD
9	141378	1	• SPACER
10	141143	1	• PLUG
11	154594	2	• SHAFT, Input
12	154595	2	• BUSHING
13	154596	1	• COVER
14	141366	1	• BEARING, Ball
15	141370	1	• SEAL
16	141371	1	• COVER
17	141134	1	• VENT
18	141144	1	• PLUG, Magnet
19	141383	4	• BOLT
20	141375	1	• SPACER
21	141376	1	• SHAFT, Output
22	141377	1	• SHAFT
23	141379	2	• BUSHING, Reduction
24	141380	10	• WASHER, Spring
25	141381	10	• BOLT
26	141149	1	• SEAL
27	141374	1	• COVER
28	141151	1	• FLANGE
29	141152	1	• O-RING
30	141372	1	• NUT
<b>K1</b>	140994	2	KIT, Shim
<b>K2</b>	141385	1	KIT, Gear

## 5.8 Drive Motor

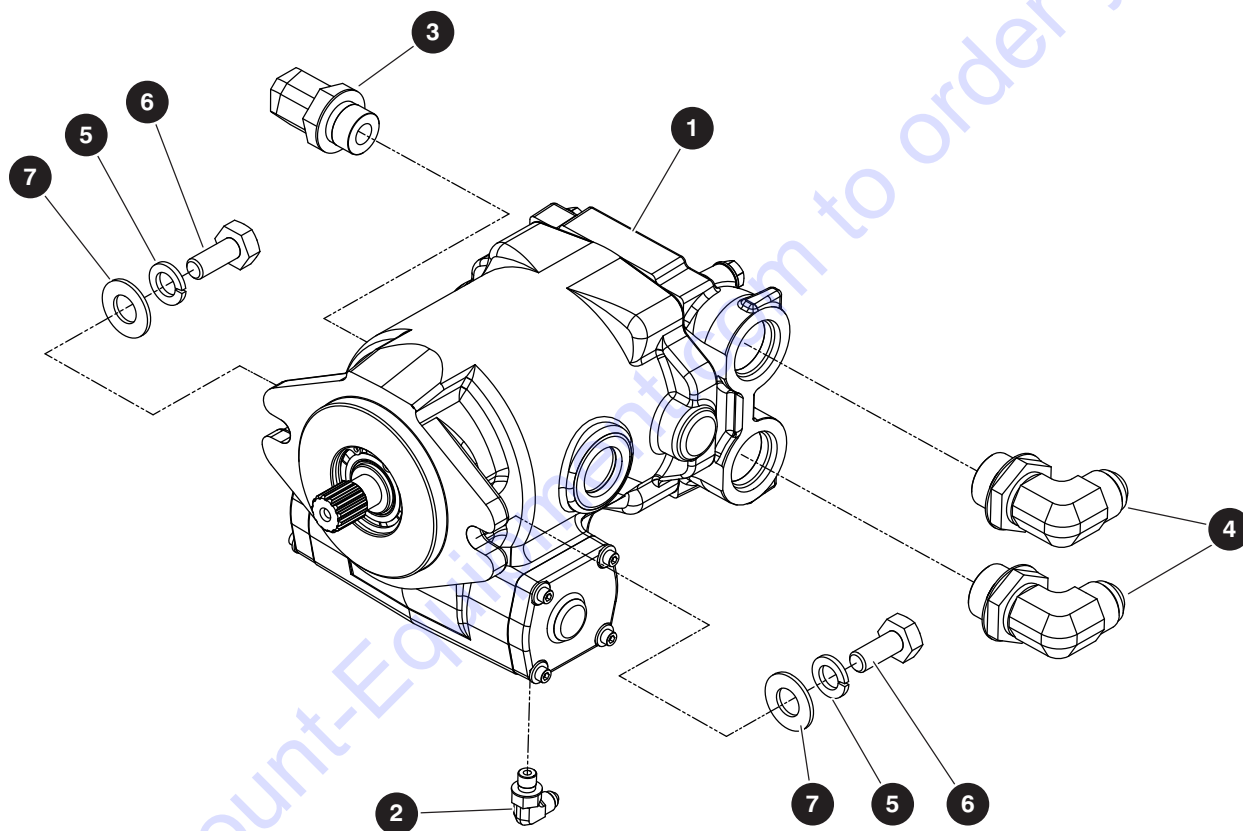

M161762AA

238271AAA

**120**

SJ45 AJ+

**SKYJACK**

## 5.8 Drive Motor

Index No.	Skyjack Part No.	Qty.	Description
-	161762	1	DRIVE MOTOR ASSEMBLY
1	161964	1	• MOTOR, Hydraulic drive
2	125883	1	• FITTING, Elbow, 90° (04 JICM - 04 ORBM)
3	112366	1	• FITTING, Elbow, 90° (08 JICM - 12 ORBM)
4	710124	2	• FITTING, Elbow, 90° (12 JICM - 16 ORBM)
5	138738	2	• WASHER, Lock (M14)
6	138734	2	• BOLT, Hex head (M14 x 2 x 30mm, ZP, Grade 8.8)
7	700782	2	• WASHER, Flat hardened (5/8")

# 5.9 Front Axle

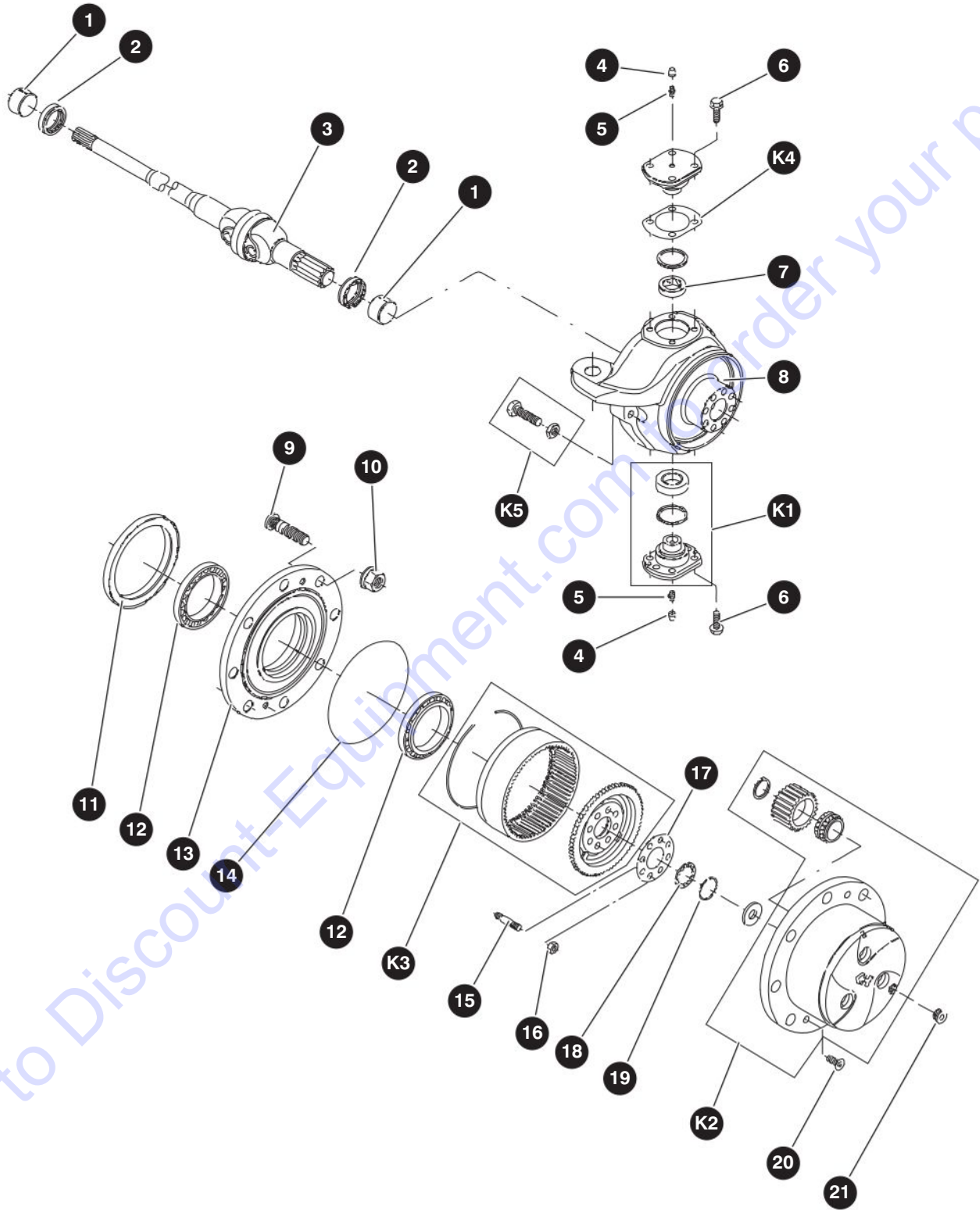

M148701AA\_HR

238271AAA

SJ45 AJ+

## 5.9 Front Axle

Index No.	Skyjack Part No.	Qty.	Description
-	218895	1	FRONT AXLE ASSEMBLY
1	TBD	2	• BUSHING, Thrust
2	TBD	4	• SEAL
3	TBD	2	• JOINT
4	TBD	4	• PLUG
5	TBD	4	• FITTING, Grease
6	TBD	20	• BOLT
7	TBD	2	• BUSHING
8	TBD	1	• CASE, Steering (Left)
	TBD	1	• CASE, Steering (Right)
9	TBD	16	• STUD, Wheel
10	TBD	16	• NUT
11	TBD	2	• SEAL
12	TBD	4	• BEARING
13	TBD	2	• HUB, Wheel
14	TBD	2	• O-RING
15	TBD	16	• STUD
16	TBD	16	• NUT
17	TBD	2	• PLATE, Locking
18	TBD	2	• SPACER
19	TBD	2	• CIRCLIP
20	TBD	4	• BOLT, Countersunk
21	TBD	2	• PLUG
<b>K1</b>	TBD	2	• KIT, Pivot pin
<b>K2</b>	TBD	2	• KIT, Planet gear carrier
<b>K3</b>	TBD	2	• KIT, Ring gear support
<b>K4</b>	TBD	2	• KIT, Shim
<b>K5</b>	TBD	4	• KIT, Steering adjust bolt

# 5.10 Differential - Front Axle

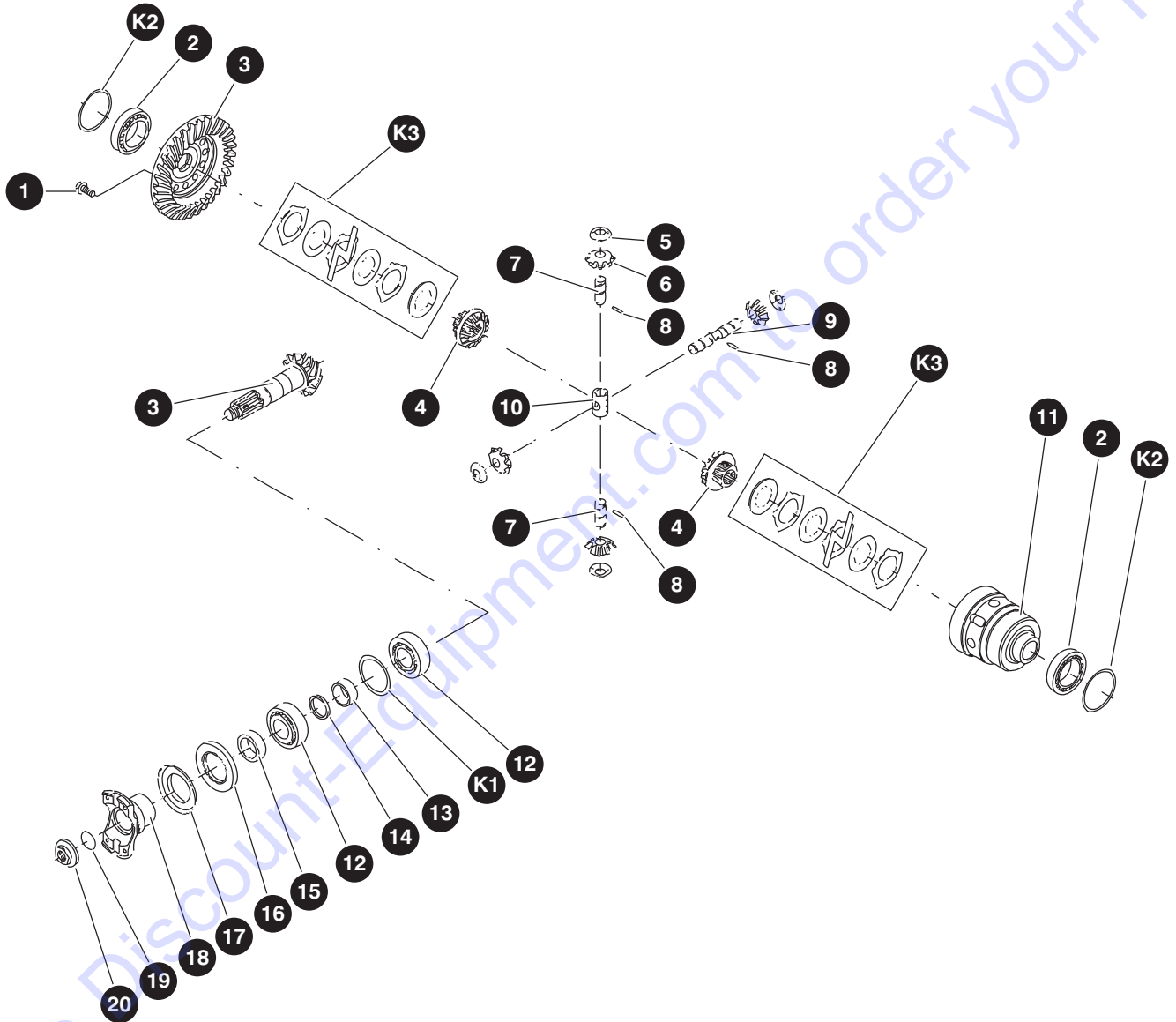

M148701AA\_D

238271AAA

SJ45 AJ+

## 5.10 Differential - Front Axle

Index No.	Skyjack Part No.	Qty.	Description
1	TBD	12	BOLT
2	TBD	2	BEARING, Taper roller
3	TBD	1	GEAR SET, Bevel
4	TBD	2	DIFFERENTIAL SIDE GEAR
5	TBD	4	WASHER, Friction
6	TBD	4	DIFFERENTIAL PINION
7	TBD	2	PIN
8	TBD	3	DOWEL
9	TBD	1	PIN
10	TBD	1	SHAFT RETAINER
11	TBD	1	DIFFERENTIAL CARRIER
12	TBD	2	BEARING
13	TBD	1	SPACER
14	TBD	1	RING
15	TBD	1	SPACER
16	TBD	1	SEAL
17	TBD	1	COVER PLATE
18	TBD	1	FLANGE
19	TBD	1	O-RING
20	TBD	1	NUT
<b>K1</b>	TBD	1	KIT, Shim
<b>K2</b>	TBD	2	KIT, Shim
<b>K3</b>	TBD	2	KIT, Clutch disc

## 5.11 Central Housing - Front Axle

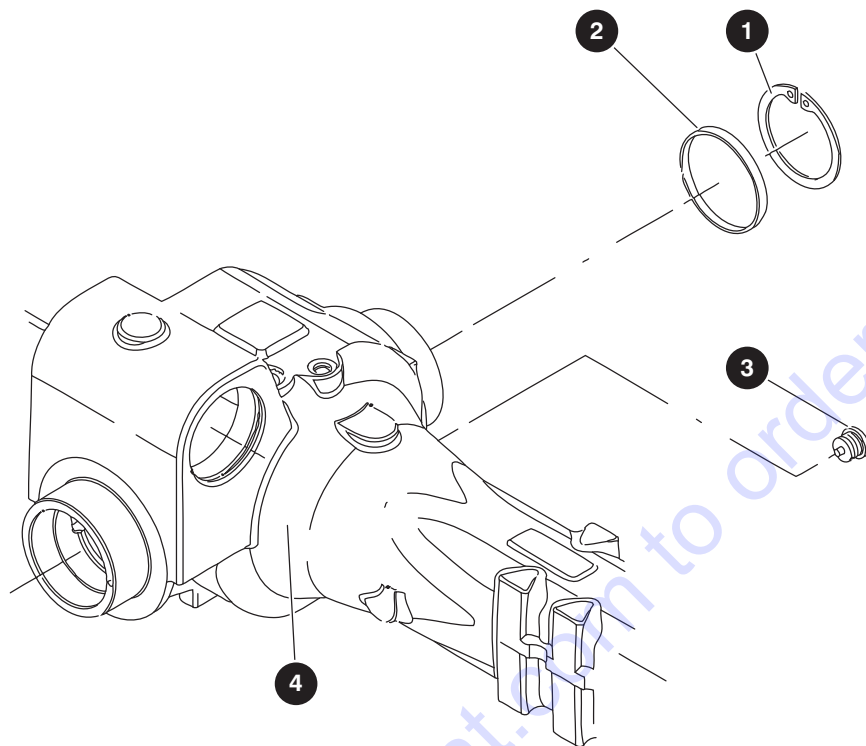

M148701AA\_CH

Index No.	Skyjack Part No.	Qty.	Description
-	154599	1	CENTRAL HOUSING ASSEMBLY
1	140966	1	• CIRCLIP
2	140967	1	• PLUG
3	154600	1	• PLUG, Magnet
4	154601	1	CASE, Axle



# 5.12 Steering Assembly

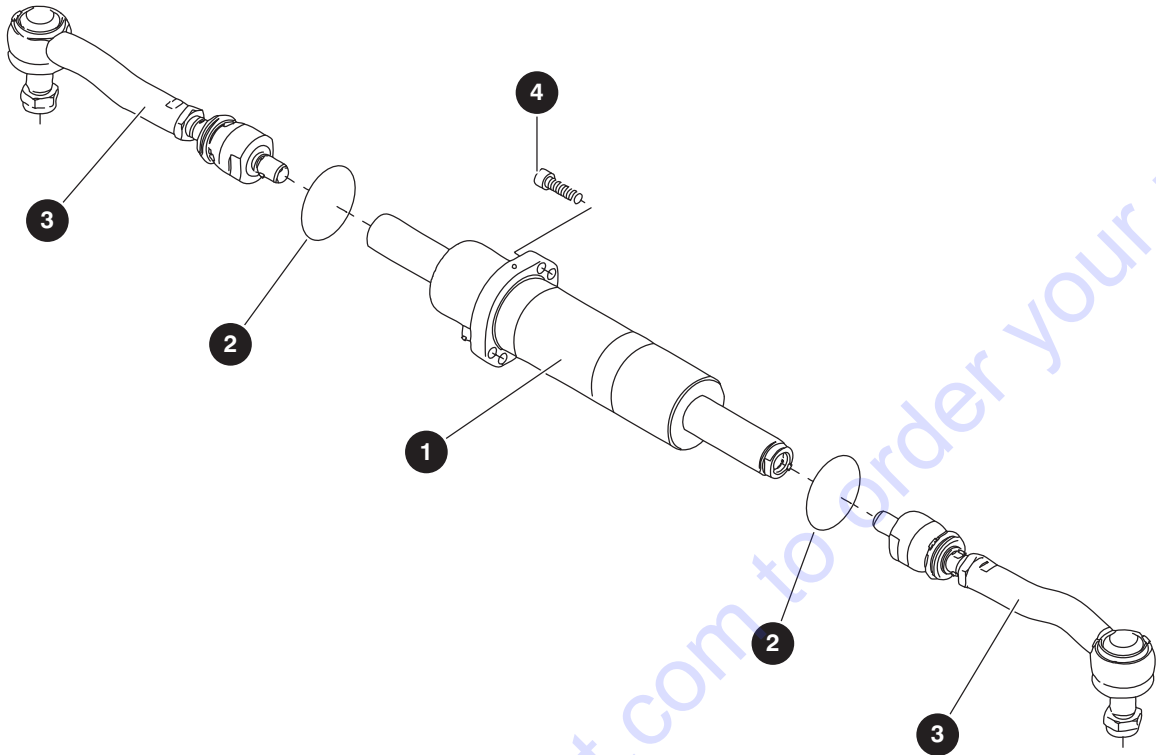

M148701AA\_S

Index No.	Skyjack Part No.	Qty.	Description
-	154640	1	STEERING ASSEMBLY
1	154641	1	• CYLINDER
2	154642	4	• RING
3	154643	2	• TIE ROD, Articulated
4	154644	4	• BOLT
<b>K</b>	168050	1	KIT, Seal (Steer Cylinder) (not shown)

## 5.13 Trunnion - Front Axle

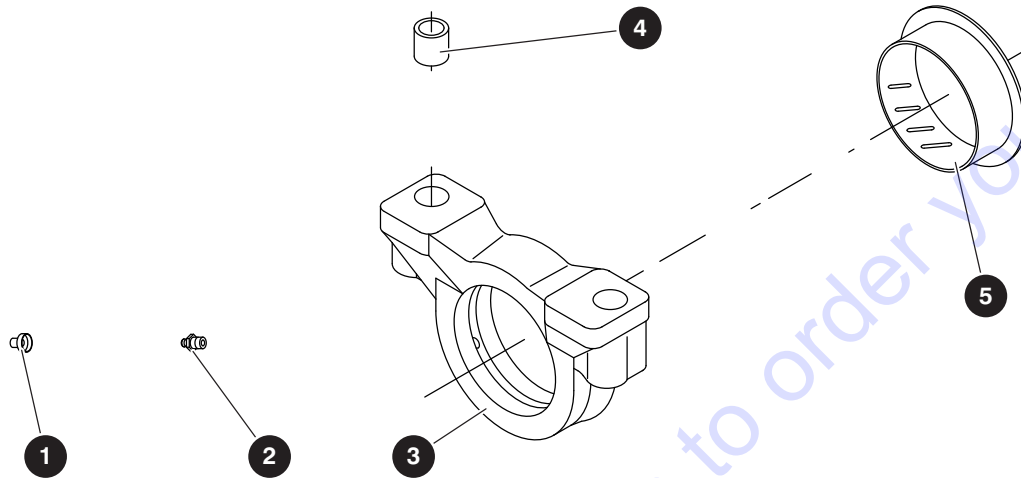

M148701AA\_T

Index No.	Skyjack Part No.	Qty.	Description
-	154647	2	SUPPORT
1	141006	2	• PLUG
2	141014	2	• FITTING, Grease
3	154646	2	• SUPPORT
4	141048	4	• BUSHING, Reduction
5	154645	2	• BUSHING, Thrust

## 5.14 Drive Shaft

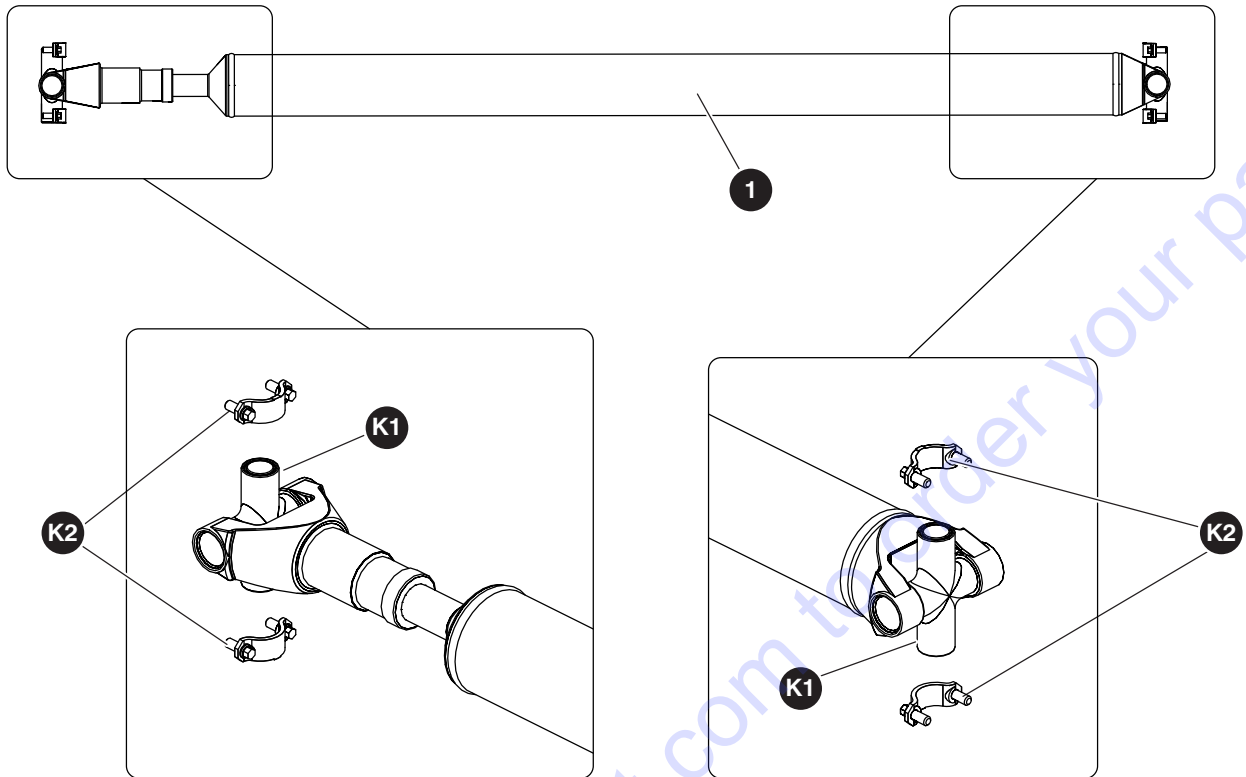

M146267AA

Index No.	Skyjack Part No.	Qty.	Description
1	148962	1	SHAFT, Drive
<b>K1</b>	216872	2	U-JOINT
<b>K2</b>	138731	2	STRAP KIT, U-joint

## 5.15 Tires

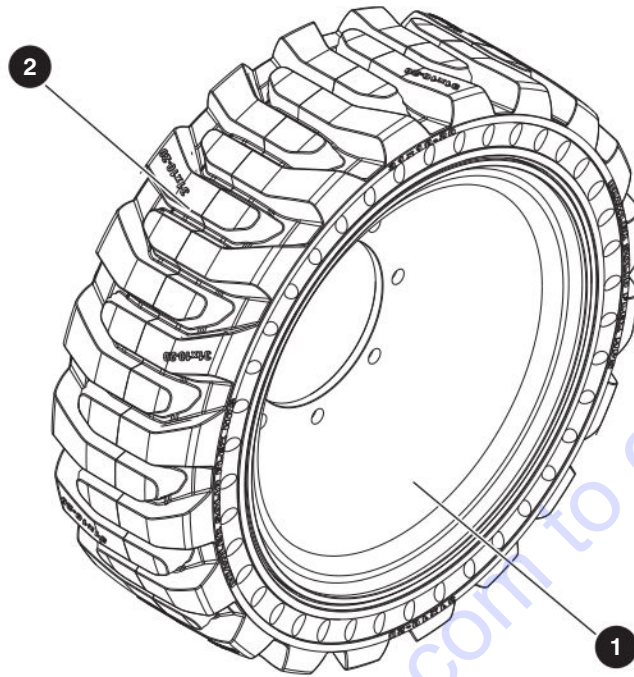

M222306AA

Index No.	Skyjack Part No.	Qty.	Description
<b>A</b>	222306	2	WHEEL ASSEMBLY, Left hand - <b>Solid</b>
	222307	2	WHEEL ASSEMBLY, Right hand - <b>Solid</b>
<b>B</b>	222078	2	WHEEL ASSEMBLY, Left hand - <b>Solid, Non-marking</b>
	222079	2	WHEEL ASSEMBLY, Right hand - <b>Solid, Non-marking</b>
1	215993	1	• RIM (7-1/2 " x 20", 2-1/2" offset)
2	215998	1	• TIRE, Brawler solid (31 x 10-20), <b>A</b>
	222080	1	• TIRE, Brawler solid (31 x 10-20), <b>B</b>

# Section 6 – Engines

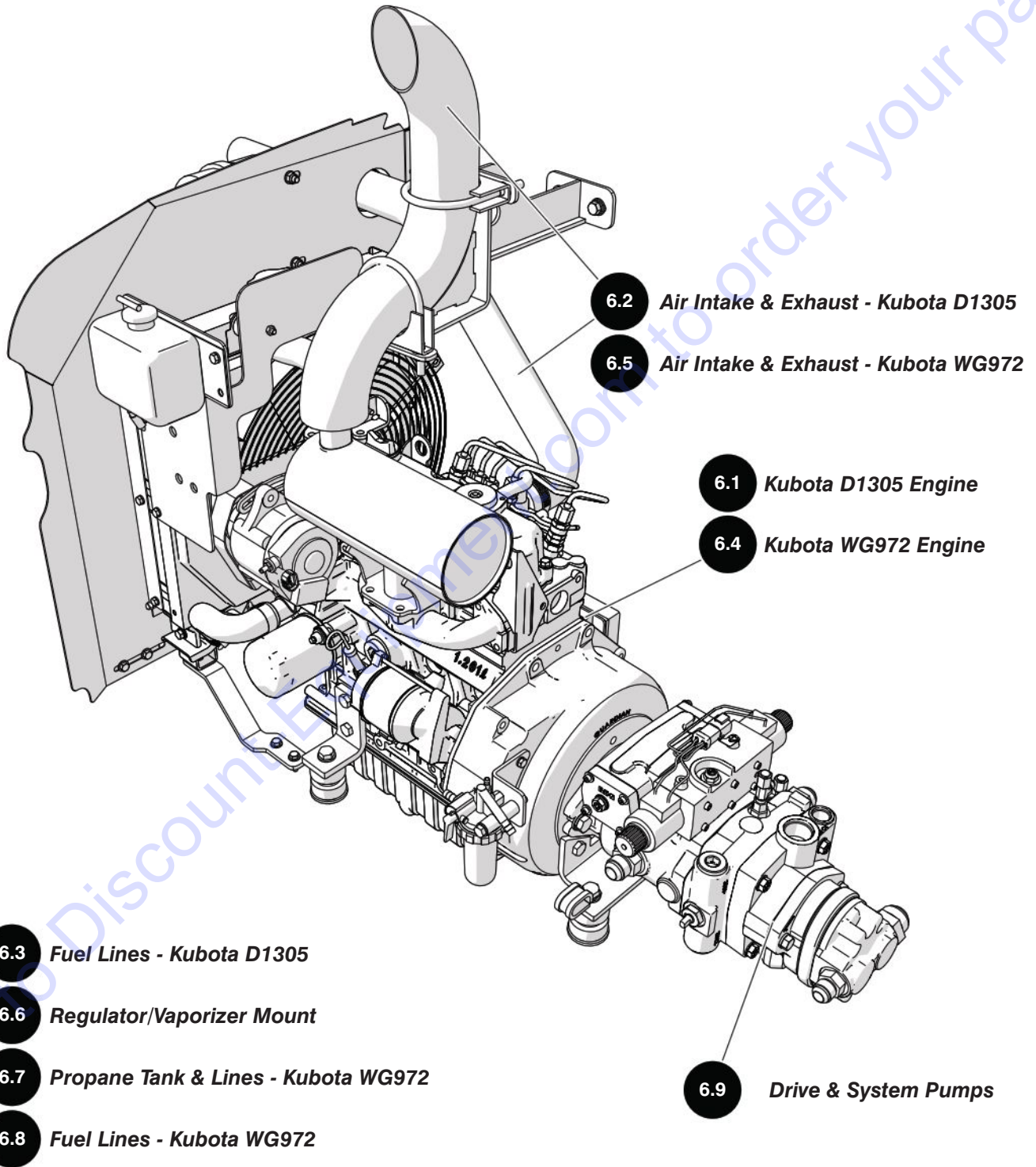

# 6.1 Kubota D1305 Engine

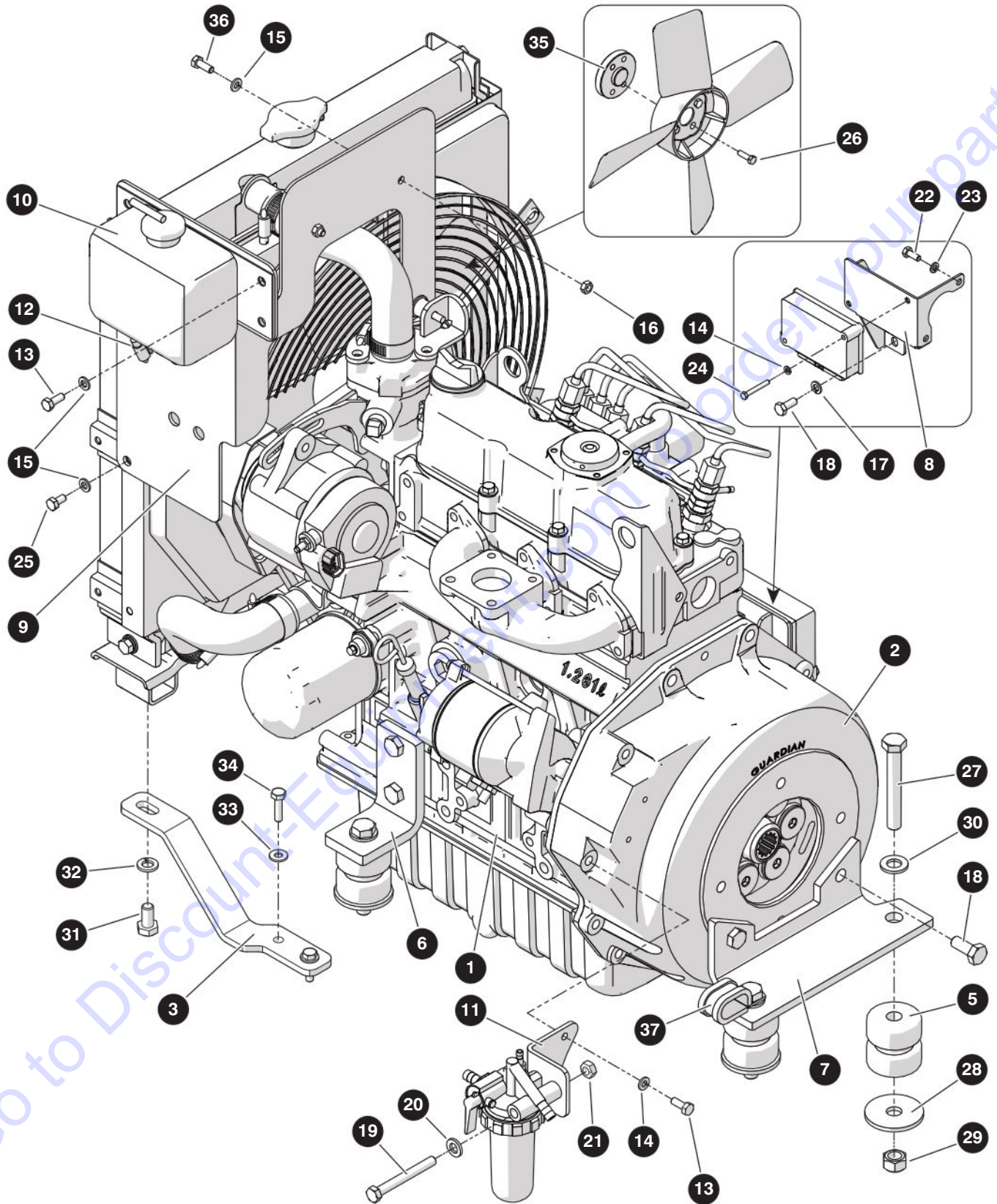

M237594AG

238271AAA

SJ45 AJ+

## 6.1 Kubota D1305 Engine

Index No.	Skyjack Part No.	Qty.	Description
-	237594	1	KUBOTA ENGINE - D1305
1	215012	1	• ENGINE, Kubota D1305 E4B
	236071	1	• • FILTER, Oil - inner
	147129	1	• • CARTRIDGE, Oil filter
	236072	1	• • STARTER
	236073	1	• • ALTERNATOR
	236074	1	• • STAY, Dynamo
	236075	1	• • GUARD, Alternator
	228540	1	• • GLOW PLUG
	236076	1	• • SOLENOID, Stop
	236077	1	• • PUMP, Water
	136109	1	• • THERMOSTAT
	210118	1	• • PIPE, Water return
	236078	1	• • FAN, Cooling
	236079	1	• • BELT, Fan
	236080	1	• • PUMP, Fuel transfer
	236081	1	• • DIPSTICK
	236082	1	• • SENSOR, Water temp
	236083	1	• • MANUAL, Operator's - Kubota D1305
	236084	1	• • GASKET, Exhaust
	236090	1	• • ECU
	236088	1	• • FUEL FILTER ASSEMBLY
	236089	1	• • • FILTER, Fuel
	236091	1	• • RADIATOR KIT
2	239474	1	• HOUSING, Flywheel - D1305
3	238504	1	• BRACKET, Radiator mount (shown)
4	238505	1	• BRACKET, Radiator mount (not shown - opposite side)
5	237586	4	• MOUNT, Vibration - 75A
6	215021	2	• BRACKET, Engine mount
7	237601	1	• BRACKET, Engine mount
8	215249	1	• BRACKET, ECU
9	238766	1	• BRACKET, Overflow tank
10	147142	1	• RESERVOIR, Coolant
11	215108	1	• BRACKET, Fuel filter
12	103321	1	• CLAMP, Gear (SAE NO. 4 - 1/4"-13/16")
13	104608	4	• BOLT, Hex head (M6 x 1 x 16 mm, gr 9.8)
14	121758	4	• WASHER Lock (M6)
15	600190	6	• WASHER, Flat (M6)
16	800354	4	• NUT, Hex head (M6-1.00)
17	132497	1	• WASHER Lock (M10)
18	228454	7	• BOLT, Hex head (M10 x 1.25 x 25, cl 8.8)
19	217410	1	• BOLT, Hex head (M8 x 1.25 x 70, cl 8.8)
20	600184	1	• WASHER, Flat (M8)
21	121059	1	• NUT, Hex head (M8-1.25, gr 5)
22	133174	1	• BOLT, Hex head (M8-1.25 x 2,0 gr 8.8)
23	116218	1	• WASHER Lock (M8)

# 6.1 Kubota D1305 Engine

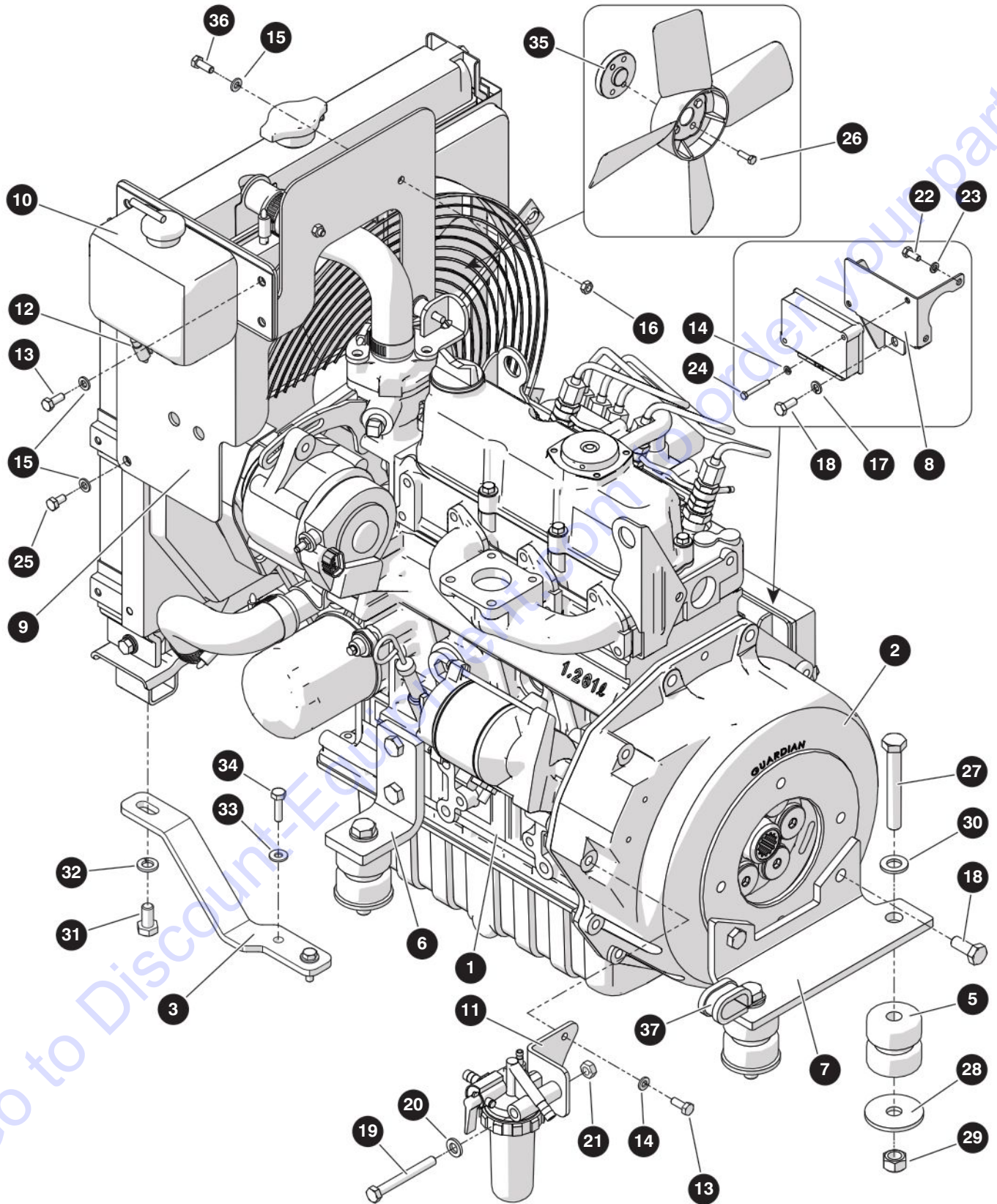

M237594AG

238271AAA

SJ45 AJ+



## 6.1 Kubota D1305 Engine

Index No.	Skyjack Part No.	Qty.	Description
24	217225	2	• BOLT, Hex head (M6 x 1 x 45, cl 8.8)
25	933646	2	• BOLT, Hex head (M6 x 1 x 12 mm, cl 8.8)
26	217871	4	• BOLT, Hex head (M6 x 1 x 20, cl 10.9)
27	217278	4	• BOLT, Hex head (M12 x 1.75 x 85, cl 8.8)
28	212939	4	• WASHER, Flat (1/2" style BB)
29	217619	4	• NUT, Torque lock (M12 x 1.75, cl 10)
30	933817	4	• WASHER, Flat (M12, cl 200 Y)
31	933740	2	• BOLT, Hex head (M10 x 1.5 x 20, cl 10.9)
32	130884	2	• WASHER Lock (M10)
33	103995	4	• WASHER, Flat (1/4")
34	103857	4	• BOLT-Hex head/ZINC (1/4"-20 x 1", gr 5)
35	238516	1	• FAN SPACER, (3/8")
36	217392	2	• BOLT, Hex head (M6 x 1 x 16, cl 8.8)
37	152333	1	• CLAMP, Tube - cushioned (5/8" with 17/32" hole)

## 6.2 Air Intake & Exhaust - Kubota D1305

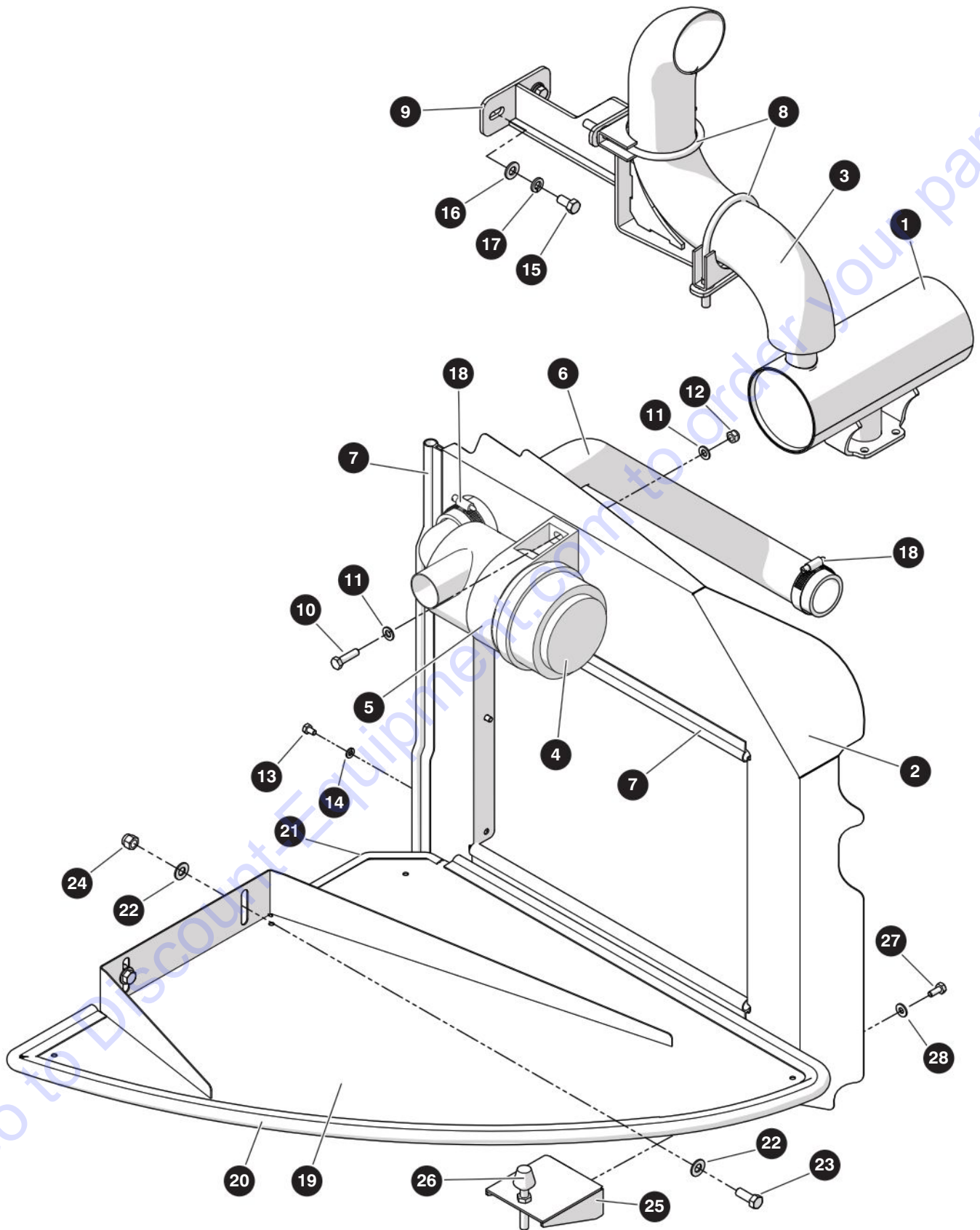

M238499AG

238271AAA

136

SJ45 AJ+

SKYJACK

## 6.2 Air Intake & Exhaust - Kubota D1305

Index No.	Skyjack Part No.	Qty.	Description
-	238499	1	AIR INTAKE & EXHAUST
1	237590	1	• MUFFLER, Kubota D1305
2	237584	1	• BAFFLE, Engine intake
3	239497	1	• TUBE, Exhaust - D1305
4	128601	1	• AIR CLEANER
	132913	1	• • ELEMENT, Filter
5	128602	1	• BAND, Mounting - air cleaner
6	238520	1	• HOSE, Intake - air cleaner
7	137625	58"	• TRIM, Rubber
8	928271	2	• CLAMP, Exhaust (3")
9	239701	1	• BRACKET, Exhaust
10	217878	2	• BOLT, Hex head (M8 x 1.25 x 30, cl 10.9)
11	933832	4	• WASHER, Flat (M8)
12	223162	2	• NUT, Lock - hex head nylon (M8 x 1.25, cl 10)
13	600723	6	• BOLT, Hex head (M6-1 x 10 mm, gr 8.8)
14	121758	6	• WASHER, Lock (M6)
15	101632	2	• BOLT, Hex head (3/8"-16 x 3/4, gr 5)
16	125959	2	• WASHER, Flat hardened (3/8")
17	103999	2	• WASHER, Lock (3/8")
18	133222	2	• CLAMP, Gear (#32)
19	238356	1	• BAFFLE, Horizontal
20	137625	21"	• TRIM, Rubber
21	220305	4"	• TRIM, Edge
22	103472	4	• WASHER, Flat (3/8")
23	103473	2	• BOLT, Hex head (3/8"-16 x 1", gr 5)
24	104606	2	• NUT, Lock (3/8"-16, gr 5)
25	238367	1	• BRACKET, Bumper
26	116494	1	• BUMPER, Vibration
27	103995	2	• WASHER, Flat (1/4")
28	103892	2	• BOLT, Hex head (1/4"-20 x 5/8", gr 5)

## 6.3 Fuel Lines - Kubota D1305

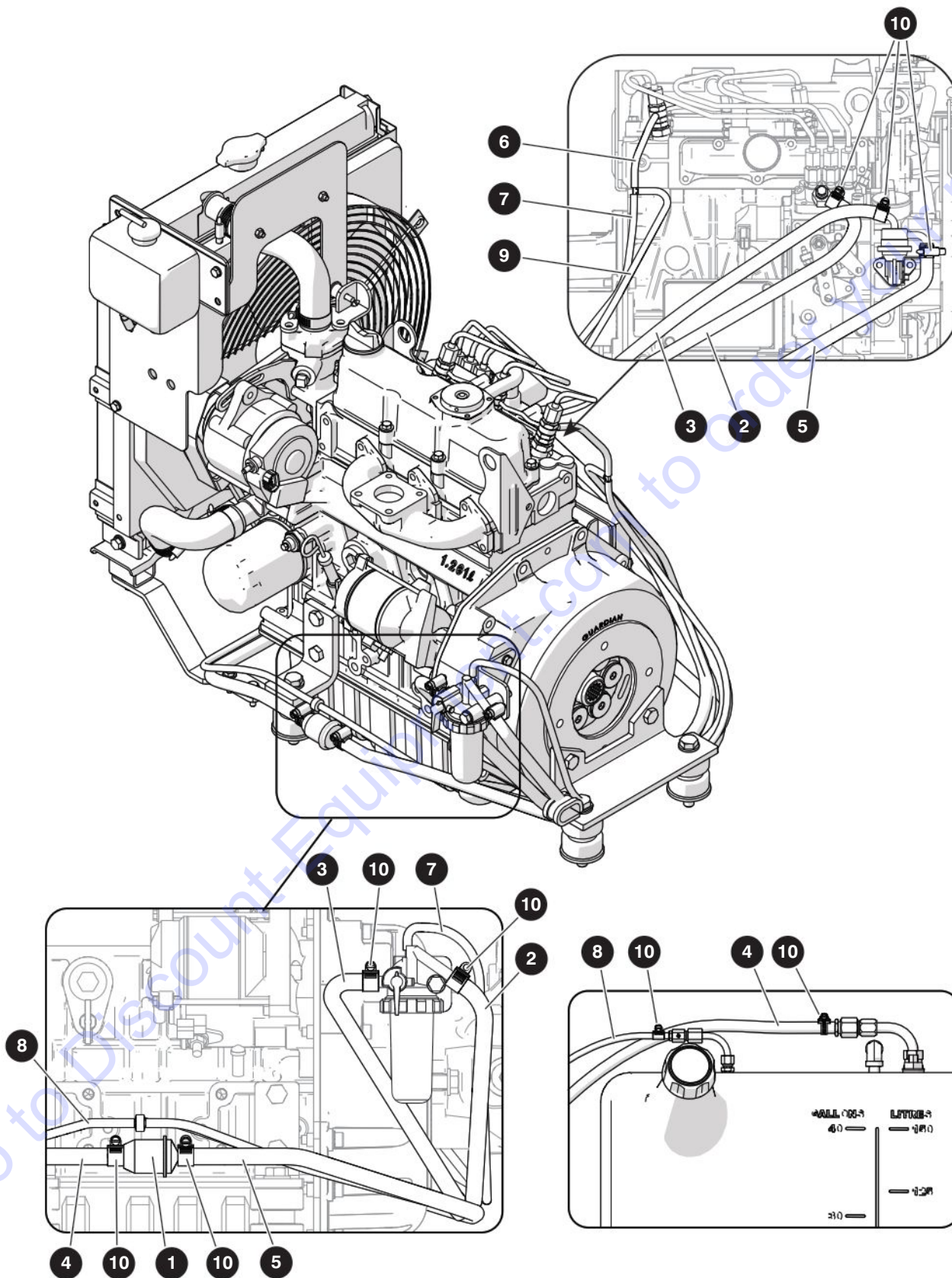

M238515AB

238271AAA

## 6.3 Fuel Lines - Kubota D1305

Index No.	Skyjack Part No.	Qty.	Description
-	238515	1	DIESEL FUEL LINES
1	139254	1	• FILTER, Fuel In-line
2	102984	48"	• FUEL LINE (5/16")
3	102984	50"	• FUEL LINE (5/16")
4	102984	120"	• FUEL LINE (5/16")
5	102984	50"	• FUEL LINE (5/16")
6	102660	5"	• HOSE, Fuel line (1/8")
7	102660	40"	• HOSE, Fuel line (1/8")
8	102660	110"	• HOSE, Fuel line (1/8")
9	102660	30"	• HOSE, Fuel line (1/8")
10	103321	9	• CLAMP, Gear

# 6.4 Kubota WG972 Engine

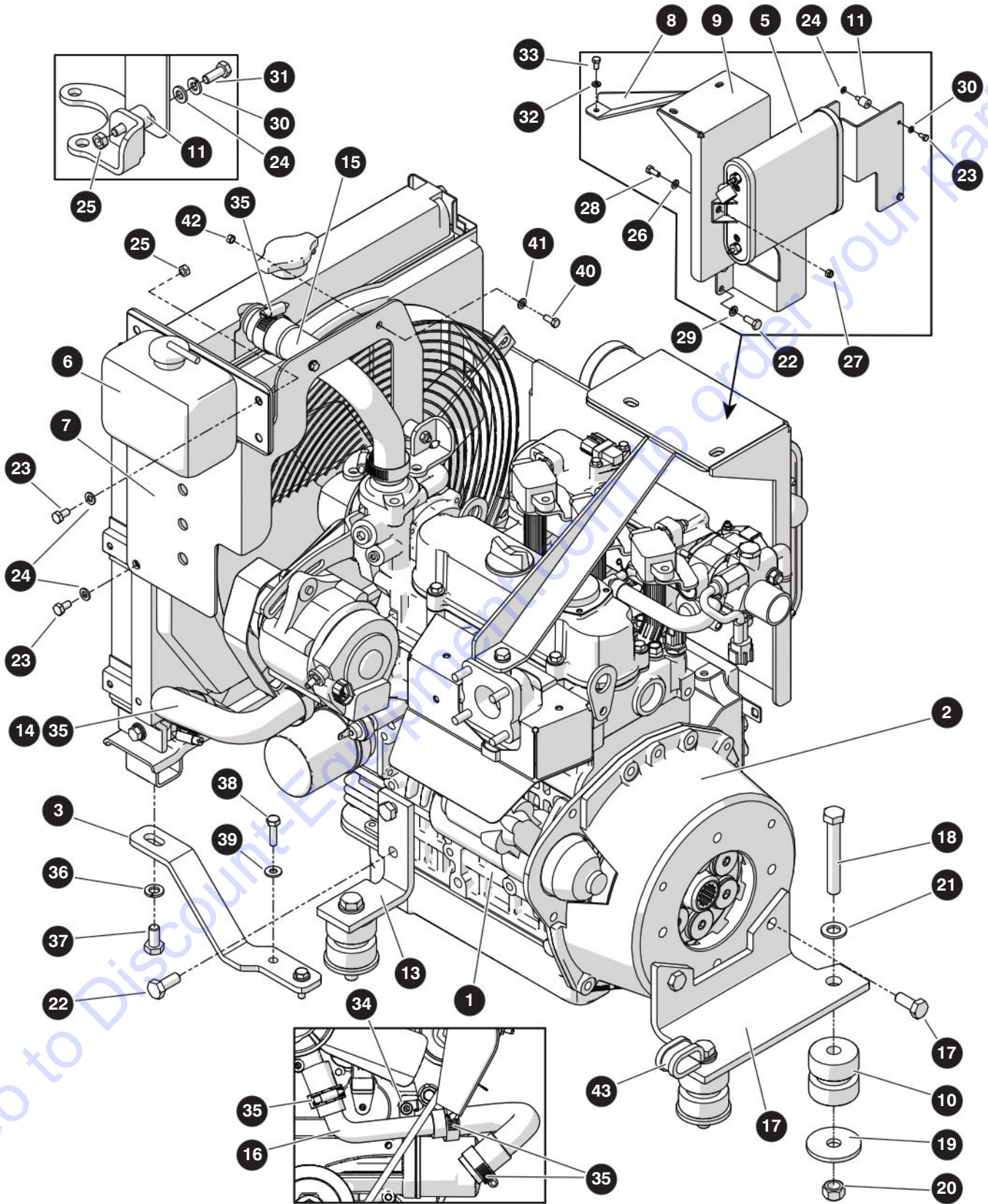

M237595AF

238271AAA

SJ45 AJ+

## 6.4 Kubota WG972 Engine

Index No.	Skyjack Part No.	Qty.	Description
-	237595	1	KUBOTA WG972 ENGINE
1	220411	1	• ENGINE, Kubota EG972 E3F
	236102	1	• • CRANKCASE
	136094	1	• • GUIDE, Oil gauge
	159207	1	• • PAN
	236103	1	• • GEAR CASE
	236104	1	• • PUMP, Water
	236105	1	• • INLET MANIFOLD
	166634	1	• • THROTTLE BODY
	236106	1	• • MIXER
	166636	1	• • EXHAUST MANIFOLD
	236107	1	• • COVER, Cylinder head
	237841	1	• • FILTER, Oil - inner
	237842	1	• • CARTRIDGE, Oil filter
	159213	1	• • DIPSTICK
	194646	1	• • PLUG, Oil gauge
	237843	1	• • ECU
	237844	1	• • STAY 1, ECU
	237845	1	• • STAY 2, ECU
	237846	1	• • WIRE HARNESS, ECU
	159216	1	• • STARTER
	237847	1	• • ALTERNATOR
	237760	1	• • STAY, Alternator
	136103	1	• • GUARD , Alternator
	166642	3	• • SPARK PLUG
	237761	1	• • FLANGE, Water
	237762	1	• • THERMOSTAT
	136110	1	• • COVER, Thermostat
	236078	1	• • FAN, Cooling
	237764	1	• • COLLAR, Fan
	136112	1	• • PULLEY, Fan
	220382	1	• • PULLEY, Fan drive
	136114	1	• • BELT, Fan
	237765	1	• • SWITCH, Oil
	237766	1	• • MANUAL, Operator's - WG972
	166645	1	• • SENSOR, O2
	136118	1	• • FILTER, Fuel
	158923	1	• • VAPORIZER
	237766	1	• • VALVE, 2 way
	166647	1	• • MUFLER, Cat
	166648	2	• • GASKET, Exhaust
	237768	1	• • COVER, Muffler
	237769	1	• • COVER, Muffler flange
	237770	1	• • HOSE Water
	237771	2	• • CLAMP, Hose
	237772	1	• • RADIATOR

# 6.4 Kubota WG972 Engine

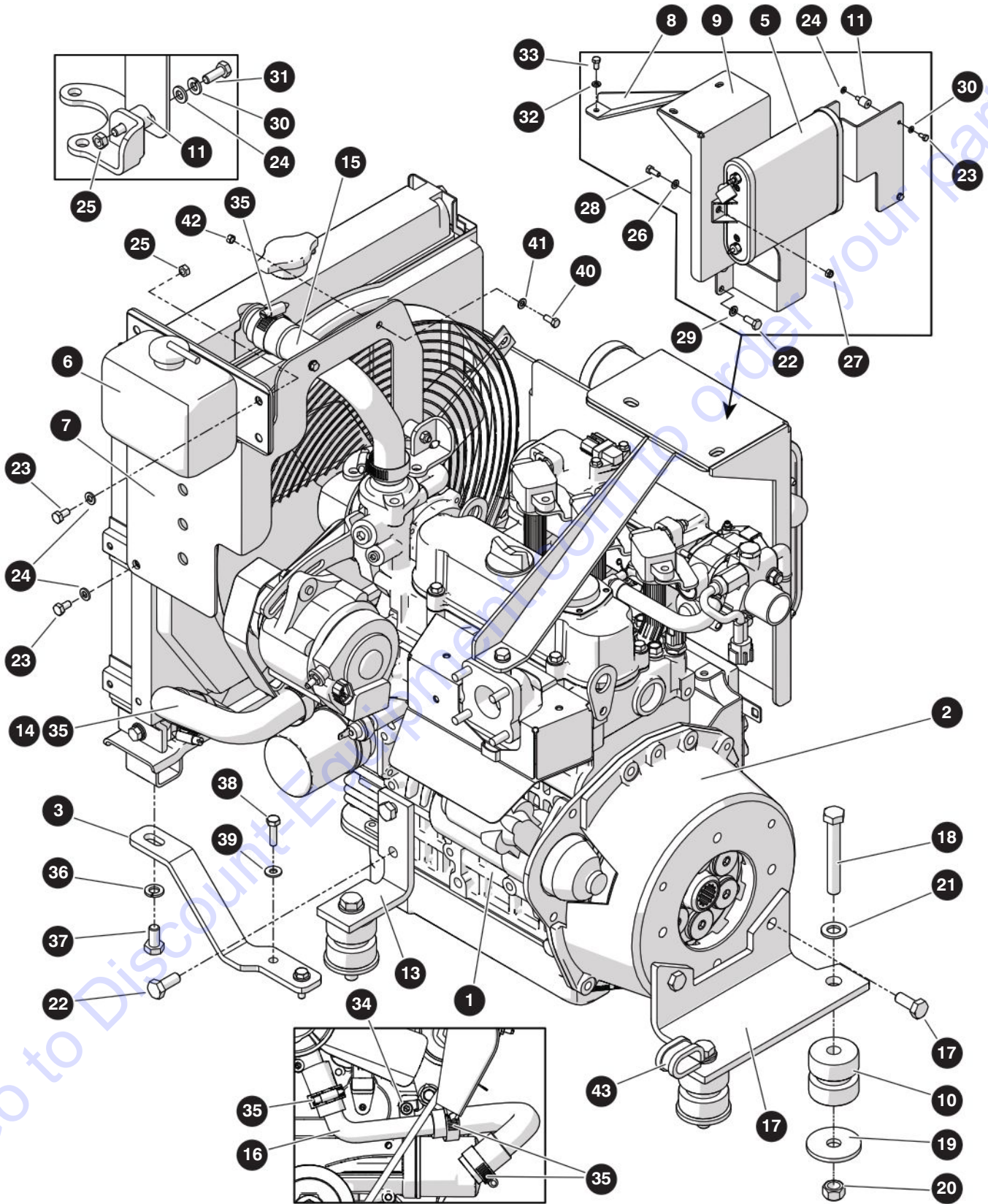

M237595AF

238271AAA

SJ45 AJ+



## 6.4 Kubota WG972 Engine

Index No.	Skyjack Part No.	Qty.	Description
2	239475	1	• HOUSING, Flywheel housing
3	238504	1	• BRACKET, Radiator mount (shown)
4	238505	1	• BRACKET, Radiator mount (not shown - opposite side)
5	158920	1	• CANISTER, Evaporative
6	147142	1	• RESERVOIR, Coolant
7	222072	1	• BRACKET, Overflow tank
8	222043	1	• SUPPORT, Evaporative canister
9	232945	1	• BRACKET, Evaporative canister
10	237586	4	• MOUNT, Vibration
11	165927	3	• MOUNT, Vibration
12	215174	1	• BRACKET, Engine mount – FL-RR (not shown - opposite side)
13	215173	1	• BRACKET, Engine mount – FR-RL (shown)
14	222074	1	• HOSE, Radiator outlet
15	222073	1	• HOSE, Radiator inlet
16	220367	1	• TUBE, Beaded
17	237602	1	• BRACKET, Engine mount
18	217278	4	• BOLT, Hex head (M12 x 1.75 x 85, cl 8.8)
19	212939	4	• WASHER, Flat hardened (0.536" x 2")
20	217619	4	• NUT, Torque lock (M12 x 1.75, cl 10)
21	933817	4	• WASHER, Flat (M12)
22	228454	10	• BOLT, Hex head (M10 x 1.25 x 25 cl 8.8)
23	933646	6	• BOLT, Hex head (M6 x 1 x 12mm cl 8.8)
24	600190	7	• WASHER, Flat (M6)
25	800354	3	• NUT, Hex head (M6-1)
26	933832	2	• WASHER, Flat (M8-16)
27	223163	2	• NUT, Hex head lock (M8 x 1.25, cl 8)
28	133174	2	• BOLT, Hex head (M8-1.25 x 20, gr 8.8)
29	132497	2	• WASHER, Lock (M10)
30	121758	3	• WASHER, Lock (M6)
31	217392	1	• BOLT, Hex head (M6 x 1 x 16, cl 8.8)
32	116218	1	• WASHER, Lock (M8)
33	217401	1	• BOLT, Hex head (M8 x 1.25 x 16, cl 10.9)
34	217083	1	• SCREW, Socket head cap (M8 x 1.25 x 20, cl 12.9)
35	133696	5	• CLAMP, Hose (1-1/2")
36	130884	2	• WASHER, Lock (M10)
37	933740	2	• BOLT, Hex head (M10 x 1.5 x 20, cl 10.9)
38	103857	4	• BOLT, Hex head (1/4"-20 x 1", gr 5)
39	103995	4	• WASHER, Flat (1/4")
40	228453	2	• BOLT, Hex head (M5 x 0.8 x 12 cl 8.8)
41	134530	2	• WASHER, Flat (M5)
42	217576	2	• NUT, Hex (M5 x 0.8, cl 8)
43	152333	1	• CLAMP, Tube - cushioned (5/8" with 17/32" hole)

## 6.5 Air Intake & Exhaust - Kubota WG972

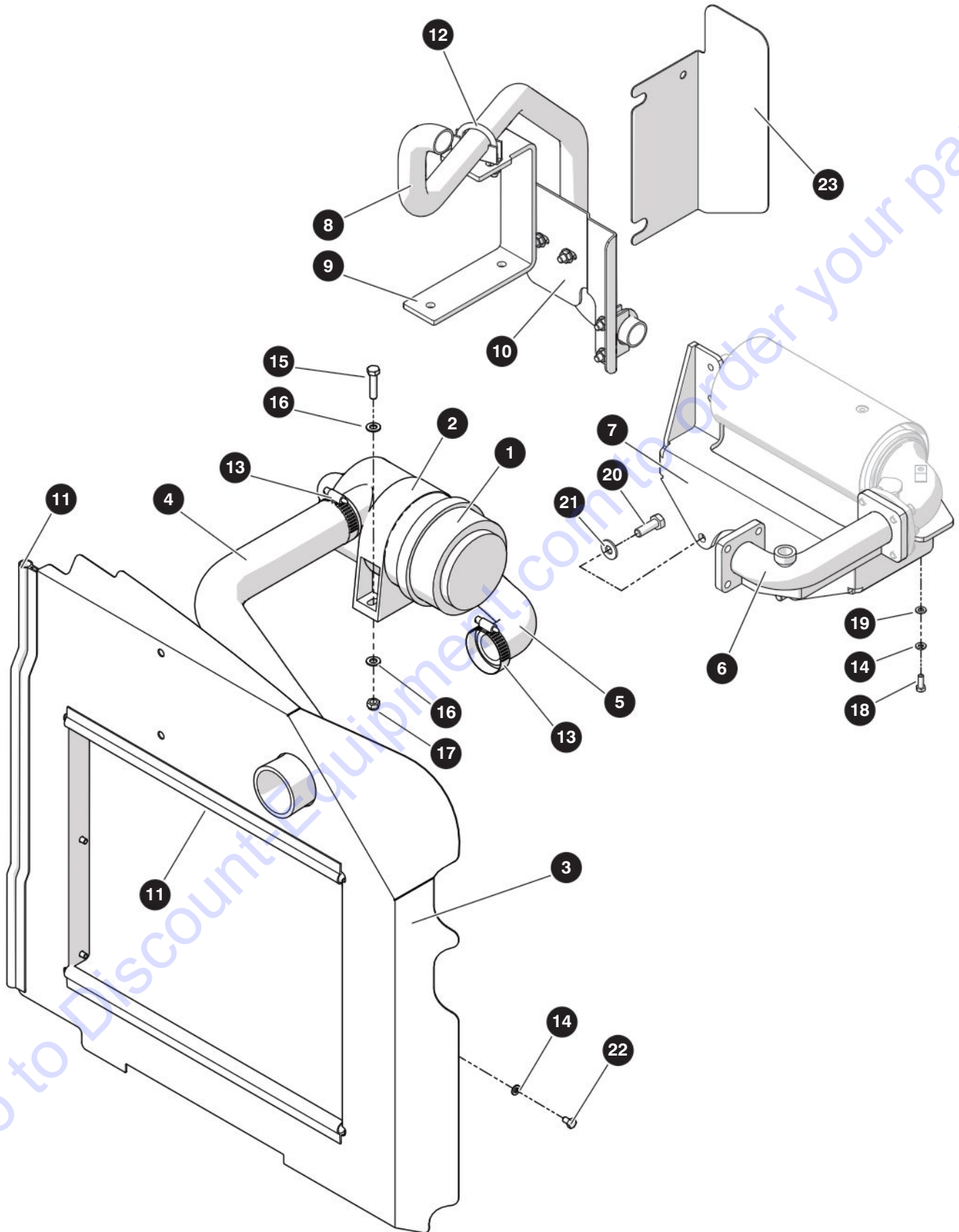

M171223AB-3

238271AAA

144

SJ45 AJ+

SKYJACK

## 6.5 Air Intake & Exhaust - Kubota WG972

Index No.	Skyjack Part No.	Qty.	Description
-	238748	1	AIR INTAKE & EXHAUST - <b>Kubota WG972</b>
1	128601	1	• AIR CLEANER
	133289	1	• • HOUSING, Filter
	132913	1	• • ELEMENT, Filter - air cleaner
2	128602	1	• BAND, Mounting - air cleaner
3	238750	1	• BAFFLE, Engine intake
4	215170	1	• TUBE, Air intake
5	220383	1	• HOSE, Air intake
6	222057	1	• ADAPTER, Exhaust
7	232946	1	• BRACKET, Exhaust
8	238719	1	• TUBE, Exhaust
9	238718	1	• BRACKET, Exhaust mount
10	238731	1	• HEAT SHIELD, Exhaust
11	137625	58	• TRIM, Rubber
12	136969	3	• CLAMP, Exhaust - U-bolt (1-1/4")
13	104528	3	• CLAMP, Hose (1-3/4")
14	121758	5	• WASHER, Lock (M6)
15	217879	2	• BOLT, Hex head (M8 x 1.25 x 30, cl 10.9)
16	933832	4	• WASHER, Flat (M8)
17	223162	2	• NUT, Lock - hex head nylon (M8 x 1.25, cl 10)
18	217870	1	• BOLT, Hex head (M6 x 1 x 16, cl 10.9)
19	600190	1	• WASHER, Flat (M6)
20	933658	2	• BOLT, Hex head (M10 x 1.5 x 30 mm, gr 10.9)
21	600572	2	• WASHER, Flat hardened (M10)
22	600723	6	• BOLT, Hex head (M6-1 x 10 mm, gr 8.8)
23	239472	1	• HEAT SHIELD, Exhaust

## 6.6 Regulator/Vaporizer Mount

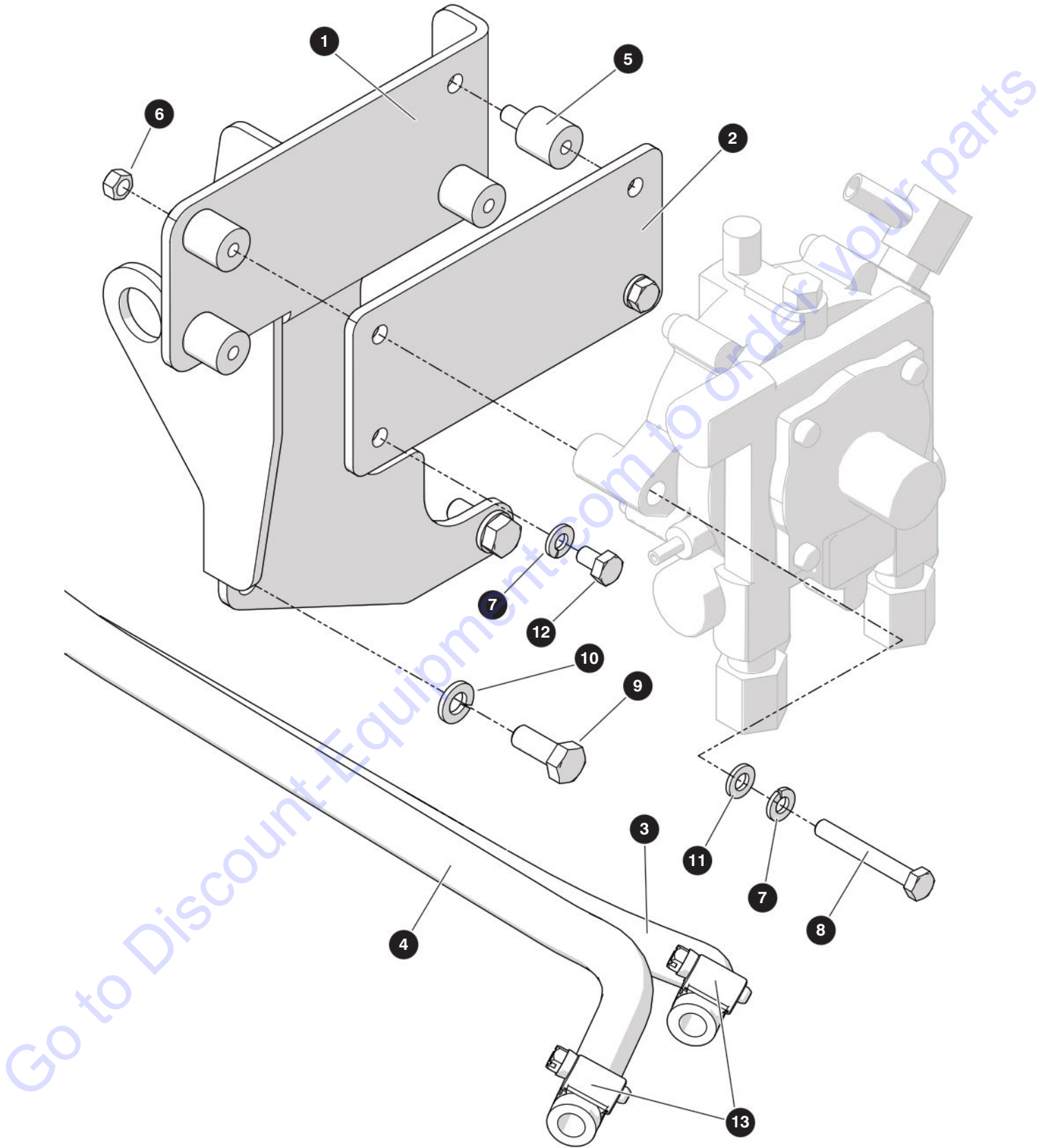

M238748AC-2

238271AAA

## 6.6 Regulator/Vaporizer Mount

Index No.	Skyjack Part No.	Qty.	Description
-	-	1	REGULATOR VAPORIZER MOUNT - <b>Kubota WG972</b>
1	220439	1	• WLDT, VAPORIZER BRACKET
2	220412	1	• PLATE, VAPORIZER MOUNTING
3	300797	17.25	• HOSE 3/8 IN 6 HORIZON 200
4	300797	20.5	• HOSE 3/8 IN 6 HORIZON 200
5	165927	4	• M6 VIBRATION DAMPING MOUNT
6	217578	4	• NUT HEX M6 X 0.75 CL 8 ZP
7	121758	6	• WASHER LOCK M6-PLATED DIN 127B
8	217398	2	• BOLT, HEX HD M6 X 1 X 45 CL 8.8 FT ZP
9	217876	2	• BOLT, HEX HD M8 X 1.25 X 20 CL 10.9 DIN 933
10	116218	2	• WASHER LOCK M8-PLATED DIN 127B
11	600190	3	• WASHER, FLAT M6 DIN 125 (600190)
12	600723	4	• BOLT, HEX HD M6 X 1 X 10, cl 8.8)
13	103321	2	• CLAMP, Gear

## 6.7 Propane Tank & Lines - Kubota WG972

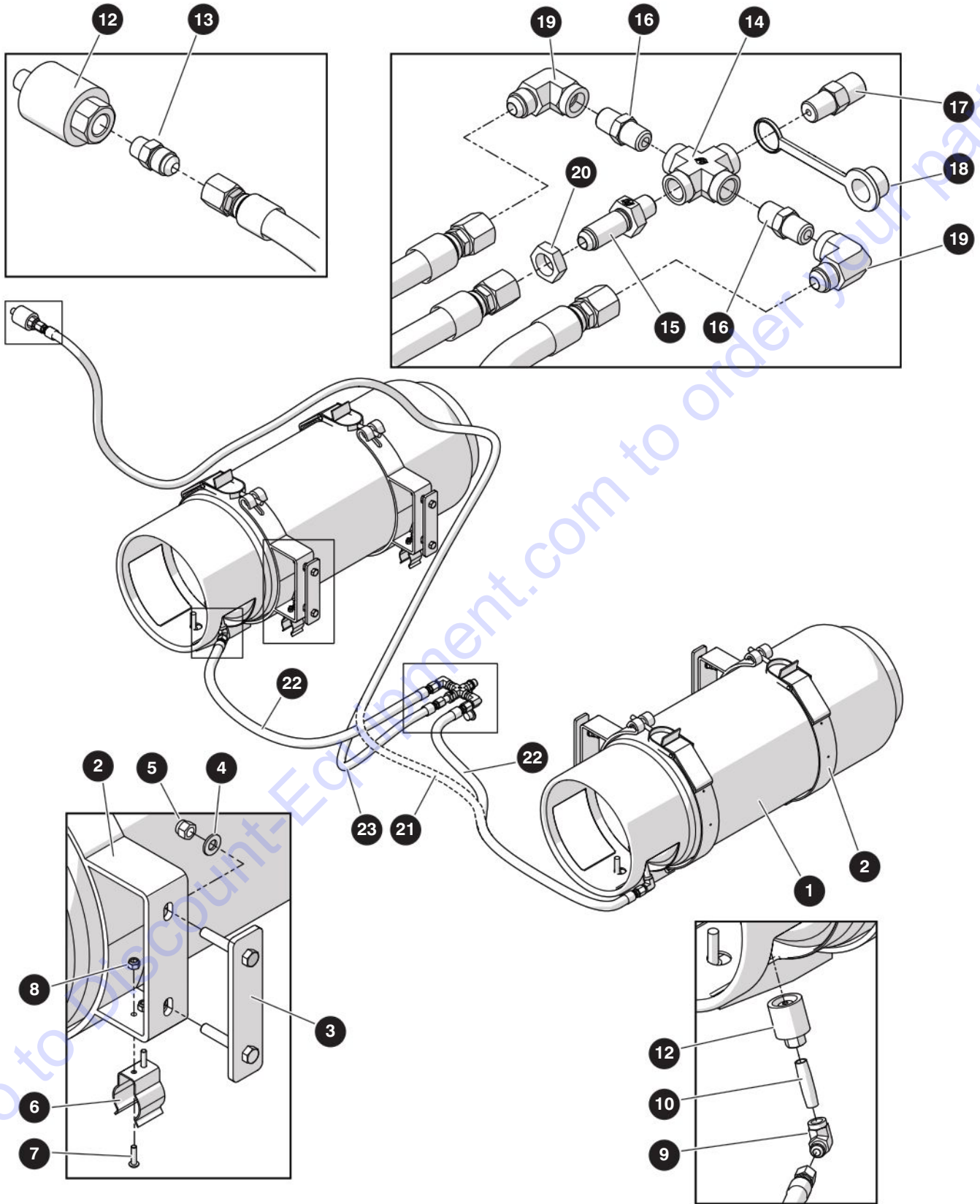

M238510AB

238271AAA

SJ45 AJ+

# PARTS FINDER

**Search Website  
by Part Number**



**Search Manual  
Library For Parts  
Manual & Lookup Part  
Numbers – Purchase  
or Request Quote**

**Search Manuals**

Enter your information to help us find the right parts manual for your equipment.

\* Brand:

\* Model:

\* Serial:

\* Part Number:

SEARCH

**Can't Find Part or  
Manual? Request Help  
by Manufacturer,  
Model & Description**

**Parts Order Form**

Please fill in the following information to help us find the right part for your equipment.

Manufacturer:	<input type="text"/>
Model:	<input type="text"/>
Description:	<input type="text"/>
Part Number:	<input type="text"/>
Quantity:	<input type="text"/>
Notes:	<input type="text"/>

Submit

Discount-Equipment.com is your online resource for quality parts & equipment.

Florida: **561-964-4949** Outside Florida TOLL FREE: **877-690-3101**

**Need parts?**

Click on this link: <http://www.discount-equipment.com/category/5443-parts/> and choose one of the options to help get the right parts and equipment you are looking for. Please have the machine model and serial number available in order to help us get you the correct parts. If you don't find the part on the website or on one of the online manuals, please fill out the request form and one of our experienced staff members will get back to you with a quote for the right part that your machine needs.

We sell worldwide for the brands: Genie, Terex, JLG, MultiQuip, Mikasa, Essick, Whiteman, Mayco, Toro Stone, Diamond Products, Generac Magnum, Airman, Haulotte, Barreto, Power Blanket, Nifty Lift, Atlas Copco, Chicago Pneumatic, Allmand, Miller Curber, Skyjack, Lull, Skytrak, Tsurumi, Husquvarna Target, Stow, Wacker, Sakai, Mi-T-M, Sullair, Basic, Dynapac, MBW, Weber, Bartell, Bennar Newman, Haulotte, Ditch Runner, Menegotti, Morrison, Contec, Buddy, Crown, Edco, Wyco, Bomag, Laymor, EZ Trench, Bil-Jax, F.S. Curtis, Gehl Pavers, Heli, Honda, ICS/PowerGrit, IHI, Partner, Imer, Clipper, MMD, Koshin, Rice, CH&E, General Equipment, Amida, Coleman, NAC, Gradall, Square Shooter, Kent, Stanley, Tamco, Toku, Hatz, Kohler, Robin, Wisconsin, Northrock, Oztec, Toker TK, Rol-Air, APT, Wylie, Ingersoll Rand / Doosan, Innovatech, Con X, Ammann, Mecalac, Makinex, Smith Surface Prep, Small Line, Wanco, Yanmar

## 6.7 Propane Tank & Lines - Kubota WG972

Index No.	Skyjack Part No.	Qty.	Description
<b>A</b>	238509	1	SINGLE PROPANE TANK
<b>B</b>	238510	1	DOUBLE PROPANE TANKS
1	702253	1	• BOTTLE, Propane (43.5#), <b>A</b>
	702253	2	• BOTTLE, Propane (43.5#), <b>B</b>
2	144295	1	• MOUNTING, Propane bottle, <b>A</b>
	144295	2	• MOUNTING, Propane bottle, <b>B</b>
	221768	2	• • BRACKET, Propane tank
	221769	2	• • LATCH
	221770	1	• • PIN, Locating
	221771	2	• • SCREW, Sem
3	149029	2	• RETAINER, Propane mount, <b>A</b>
	149029	4	• RETAINER, Propane mount, <b>B</b>
4	125959	4	• WASHER, Flat hardened (3/8"), <b>A</b>
	125959	8	• WASHER, Flat hardened (3/8"), <b>B</b>
5	104606	4	• NUT, Hex lock (3/8"-16 Grade 5, nylon), <b>A</b>
	104606	8	• NUT, Hex lock (3/8"-16 Grade 5, nylon), <b>B</b>
6	137235	2	• CLIP, Gripper (1.5"-2.5 diameter), <b>A</b>
	137235	4	• CLIP, Gripper (1.5"-2.5 diameter), <b>B</b>
7	138834	4	• SCREW, Round head machine (#10-24 x 3/4"), <b>A</b>
	138834	8	• SCREW, Round head machine (#10-24 x 3/4"), <b>B</b>
8	126642	4	• NUT, Hex lock (#10-24 Grade 5, nylon), <b>A</b>
	126642	8	• NUT, Hex lock (#10-24 Grade 5, nylon), <b>B</b>
9	144334	1	• FITTING, Elbow 90° (06 SAE 45M - 04 NPTF), <b>A</b>
	144334	2	• FITTING, Elbow 90° (06 SAE 45M - 04 NPTF), <b>B</b>
10	143478	1	• NIPPLE, Brass (1/4 NPT x 2"), <b>A</b>
	143478	2	• NIPPLE, Brass (1/4 NPT x 2"), <b>B</b>
11	103006	1	• QUICK COUPLING, Female tank, <b>A</b>
	103006	2	• QUICK COUPLING, Female tank, <b>B</b>
12	125793	1	• VALVE, Shut off
13	103156	1	• FITTING, Straight (06 SAE 45M - 04 NPTM), <b>A</b>
-	235352	1	• PROPANE TEE, <b>B</b>
14	235350	1	• • FITTING, Cross (04NPTF-04NPTF-04NPTF-04NPTF)
15	235351	1	• • FITTING, Bulkhead (04NPTM-06JICM)
16	230931	2	• • VALVE, Check - 2 psi
17	130099	1	• • VALVE, Relief - 04NPT
18	111622	1	• • CAP, Rain
19	144334	2	• • FITTING, 90° (06JICM-04NPTF)
20	139157	1	• • FITTING, Bulkhead nut (06JIC)
21	211434	1	• HOSE, Propane (156"), <b>A</b>
22	103098	2	• HOSE, Propane (42"), <b>B</b>
24	211429	1	• HOSE, Propane (135"), <b>B</b>



## 6.8 Fuel Lines - Kubota WG972

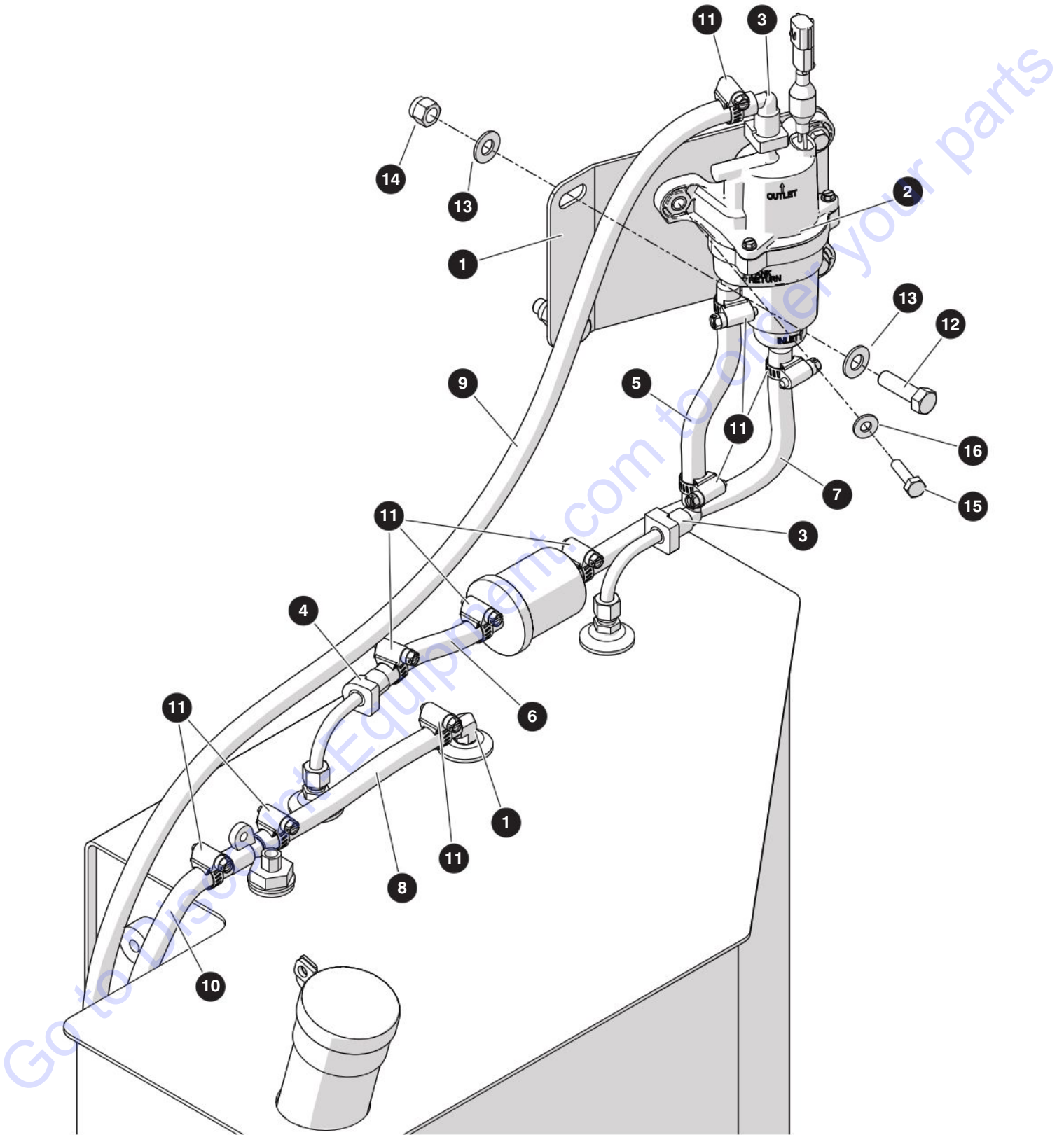

M238510AB

238271AAA

150

SJ45 AJ+

SKYJACK

## 6.8 Fuel Lines - Kubota WG972

Index No.	Skyjack Part No.	Qty.	Description
-	238517	1	FUEL LINES - <b>Kubota WG972</b>
1	238518	1	• BRACKET, Mount - fuel pump
2	237610	1	• FUEL PUMP, Gasoline
3	142398	2	• FITTING, 90° quick connect - fuel
4	142397	1	• FITTING, Straight quick connect - fuel
5	142405	7"	• FUEL LINE (5/16")
6	142405	5"	• FUEL LINE (5/16")
7	142405	10"	• FUEL LINE (5/16")
8	142405	7"	• FUEL LINE (5/16")
9	142405	120"	• FUEL LINE (5/16")
10	142405	115"	• FUEL LINE (5/16")
11	103321	12	• CLAMP, Gear
12	101297	2	• BOLT, Hex head (3/8"-16 x 1-1/4", gr 5)
13	103472	4	• WASHER, Flat (3/8")
14	104606	5	• NUT, Lock (3/8"-16, gr 5)
15	103857	6	• BOLT, Hex head (1/2"-20 x 1", gr 5)
16	103995	6	• WASHER, Flat (3/8")

## 6.9 Drive & System Pumps

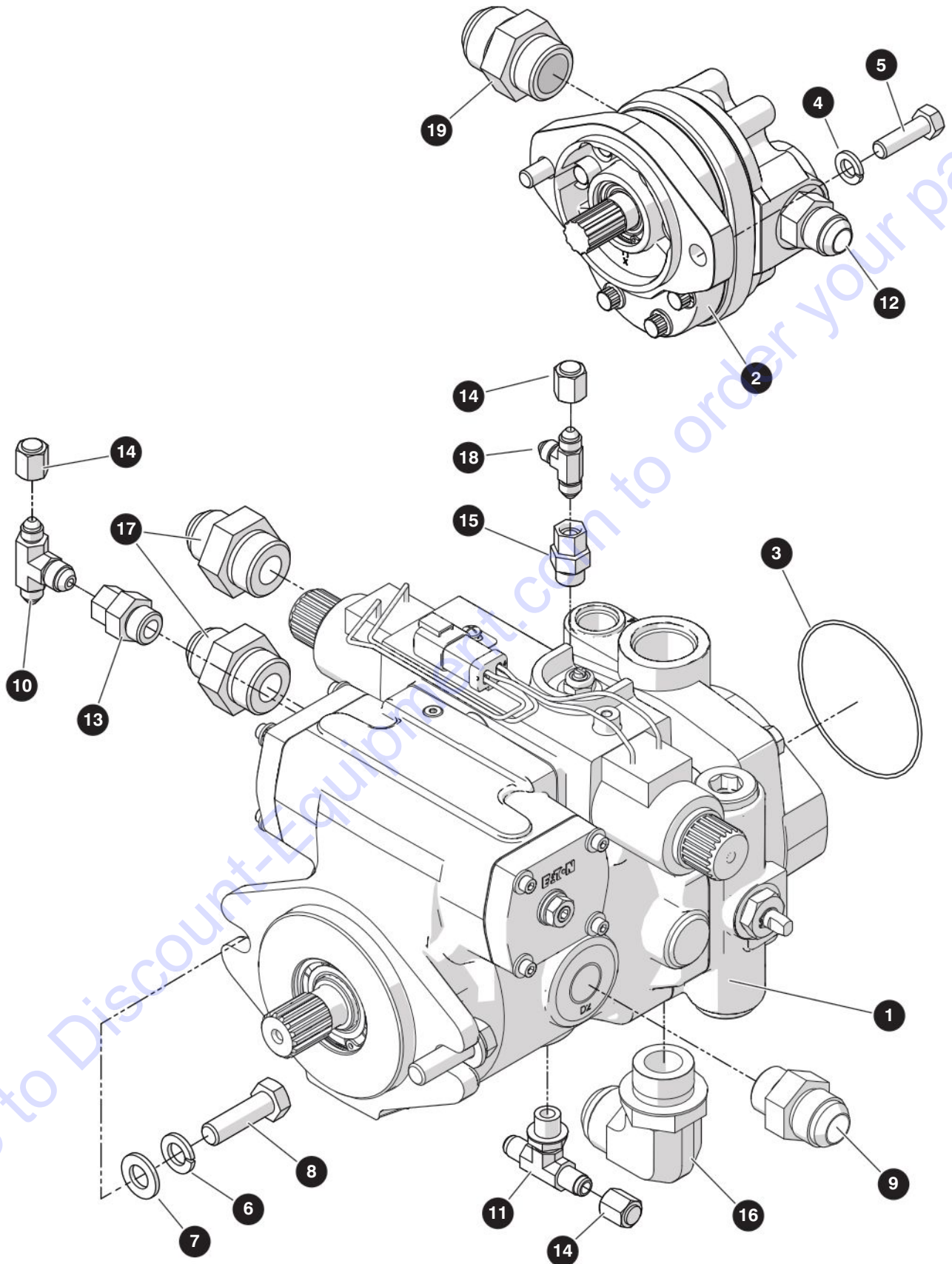

M238498AB

238271AAA

SJ45 AJ+

## 6.9 Drive & System Pumps

Index No.	Skyjack Part No.	Qty.	Description
-	237597	1	DRIVE & SYSTEM PUMPS
1	170599	1	• PUMP, Drive
2	161963	1	• PUMP, System
3	162387	1	• O-RING (3-1/4" x 1/16")
4	103999	2	• WASHER, Lock (3/8")
5	101297	2	• BOLT, Hex head (3/8"-16 x 1-1/4", gr 5)
6	600549	2	• WASHER, Lock (M12)
7	600426	2	• WASHER, Flat (M12)
8	217892	2	• BOLT, Hex head (M12 x 1.75 x 40, cl 10.9)
9	702118	1	• FITTING, Straight (12JICM-12ORBM)
10	162044	1	• FITTING, Tee (04JICM-04JICM-06JICM)
11	148490	1	• FITTING, Brach tee (04JICM-04JICM-06ORBM)
12	137630	1	• FITTING, Straight (10JICM-10ORBM)
13	162043	1	• FITTING, Straight (06JICFS-08ORBM)
14	131286	3	• FITTING, Cap (04JICF)
15	160885	1	• FITTING, Straight (06 ORBM-04 JICFS)
16	707040	1	• FITTING, 90° (16JICM-16ORBM)
17	702122	2	• FITTING, Straight (12JICM-16ORBM)
18	131697	1	• FITTING, Tee (04JICM)
19	138667	1	•
20	160637	1	SEAL KIT, Drive Pump

## Section 7 – Electrical Harnesses

**7.1** *Main Electrical & Fuel Level Switch Harnesses*

**7.2** *Engine Harness - Kubota D1305*

**7.3** *Engine Fuse Box - Kubota D1305*

**7.4** *Engine Harness - Kubota WG972*

**7.5** *ECU Power Harness - Kubota WG972*

**7.6** *Fuel Pump Harness - Kubota WG972*

**7.7** *Battery Cables*

**7.9** *Jib & Platform Rotate Valve Harnesses*

# 7.1 Main Electrical & Fuel Level Switch Harnesses

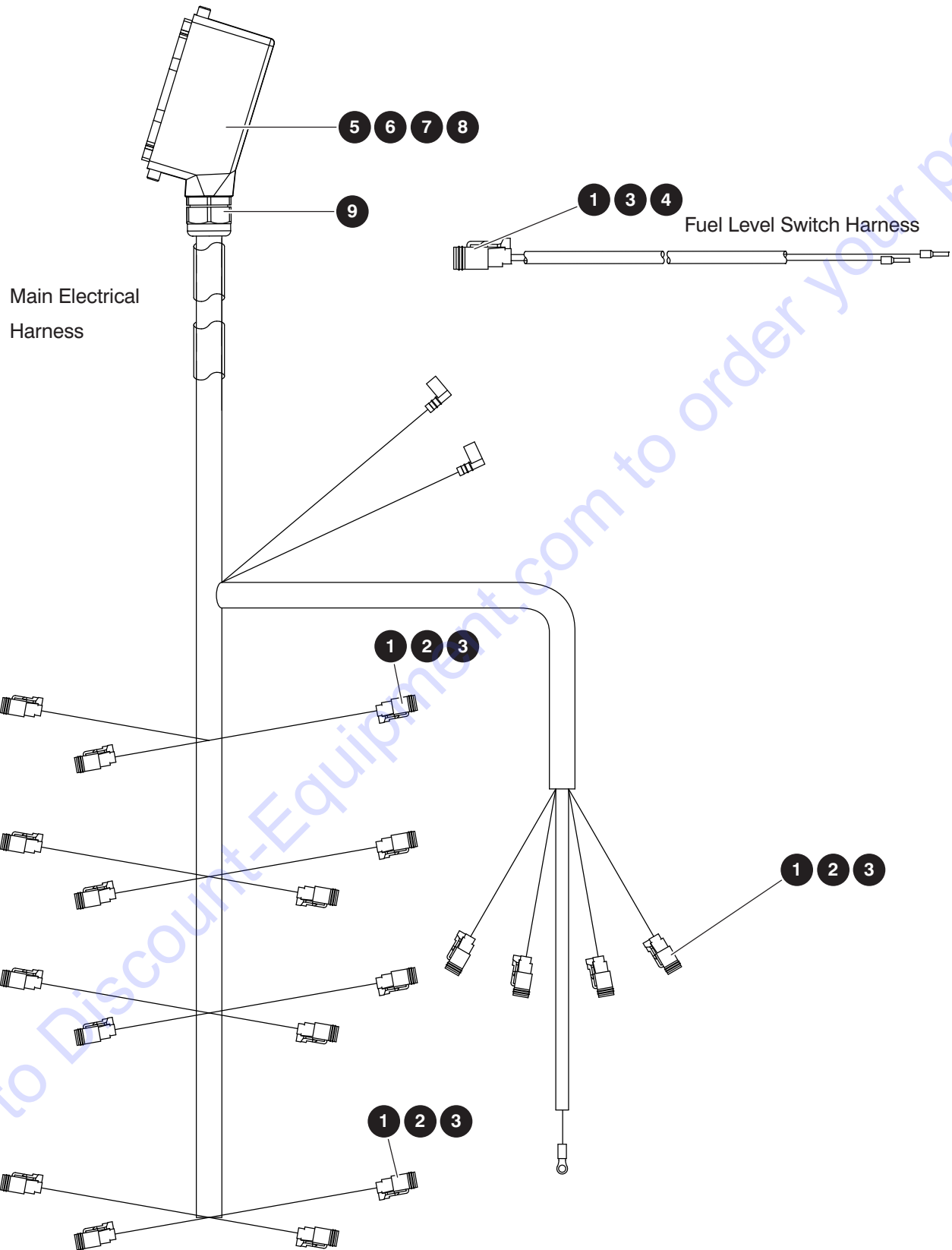

M149012AA

238271AAA

SJ45 AJ+

## 7.1 Main Electrical & Fuel Level Switch Harnesses

Index No.	Skyjack Part No.	Qty.	Description
<b>A</b>	218488	1	HARNESS, Main electrical
<b>B</b>	218487	1	HARNESS, Fuel level switch
1	117597	19	• PLUG, Deutsch (2-pin), <b>A</b>
		1	• PLUG, Deutsch (2-pin), <b>B</b>
2	117591	38	• SOCKET, Deutsch (16/18 GA)
3	117599	19	• WEDGE, Deutsch (2-pin), <b>A</b>
		1	• WEDGE, Deutsch (2-pin), <b>B</b>
4	117590	2	• CONNECTOR, Contact (16-18)
5	138753	1	• HOOD, Side 24 pole (M32)
6	138755	1	• PLUG, 24 pole spring (16A)
7	115401	21	• FERULE (18GA)
8	138044	4	• FERULE (14GA)
9	138754	1	• STRAIN, RELIEF (M32 x 1.5)

## 7.2 Engine Harness - Kubota D1305

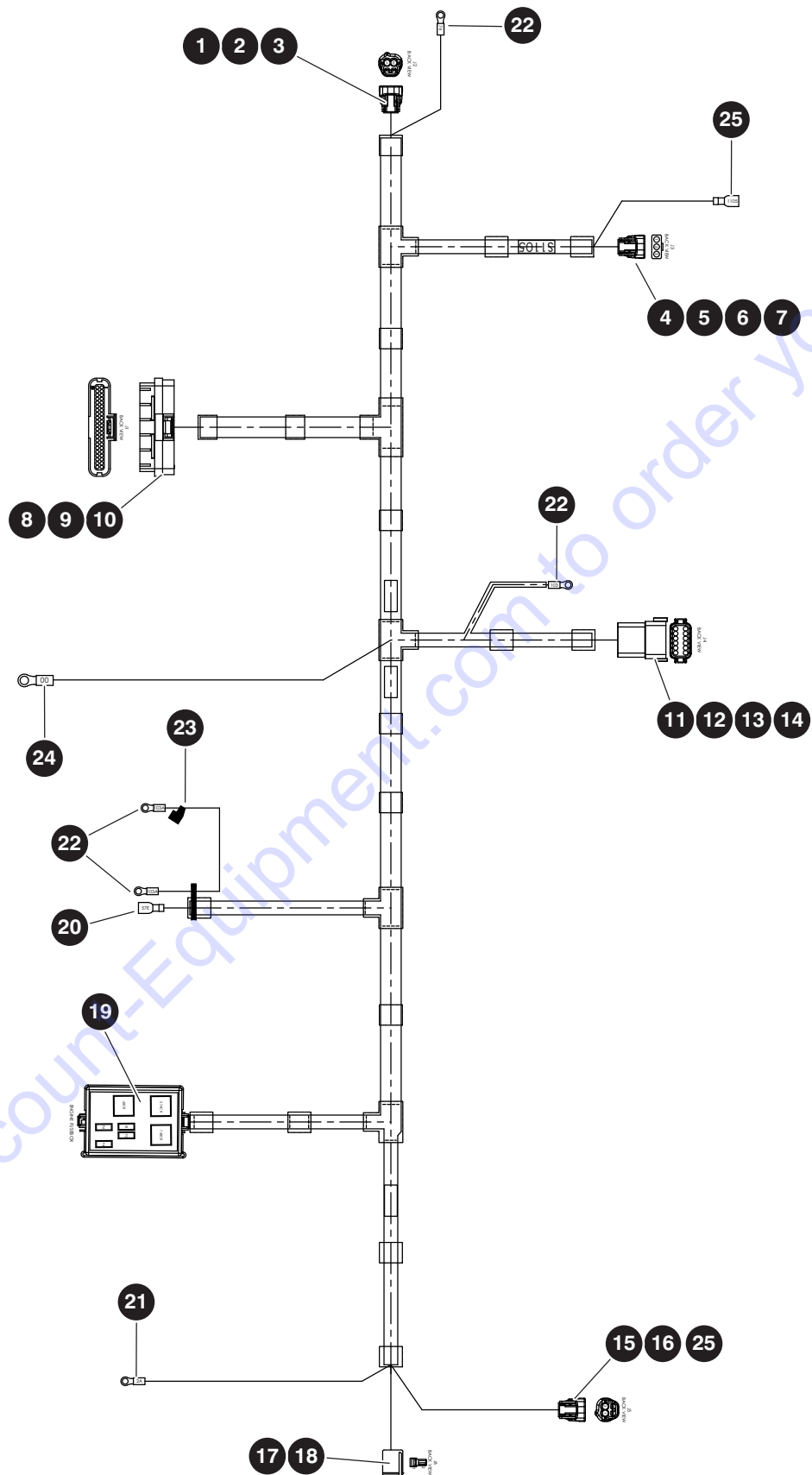

M218405AD-1

238271AAA



## 7.2 Engine Harness - Kubota D1305

Index No.	Skyjack Part No.	Qty.	Description
-	236167	1	ENGINE HARNESS
1	215850	1	• CONNECTOR, 2 Pole - automotive
2	215852	2	• CONTACT, Female - automotive
3	215853	2	• SEAL, Wire - automotive
4	215864	1	• CONNECTOR, 3 Pole - automotive
5	215866	3	• CONTACT, Female - automotive
6	215867	3	• SEAL, Wire - automotive
7	215865	1	• CONNECTOR, Rear holder
8	215868	1	• CONNECTOR, 44 position - ECU
9	215869	22	• CONTACT, Female - ECU
10	215870	22	• PLUG, Wire - ECU
11	117586	1	• CONNECTOR, Receptacle (12 pin)
12	117589	1	• CONNECTOR, Receptacle - wedge (12 pin)
13	117590	7	• CONNECTOR, Contact (PIN 16 - 18)
14	117594	5	• CONNECTOR, Sealing plug
15	215871	1	• CONNECTOR, 2 Pole - automotive
16	215872	2	• CONTACT, Female - automotive
17	215874	1	• CONNECTOR, 2 Pole - alternator
18	215875	2	• CONTACT, Female - alternator
19	(Ref.)	1	• FUSEBOX (For components, refer to 7.3 Engine Fuse Box - Kubota D1305)
20	105568	1	• TERMINAL, Female - yellow 10-12 AWG
21	216788	1	• TERMINAL, Ring - red 18-22 GA
22	108172	1	• TERMINAL, Ring 10-12 GA
23	117696	1	• BOOT, Terminal
24	114595	1	• TERMINAL, Female 18-22 GA
25	238414	2	• WIRE SEAL, Amp

## 7.3 Engine Fuse Box - Kubota D1305

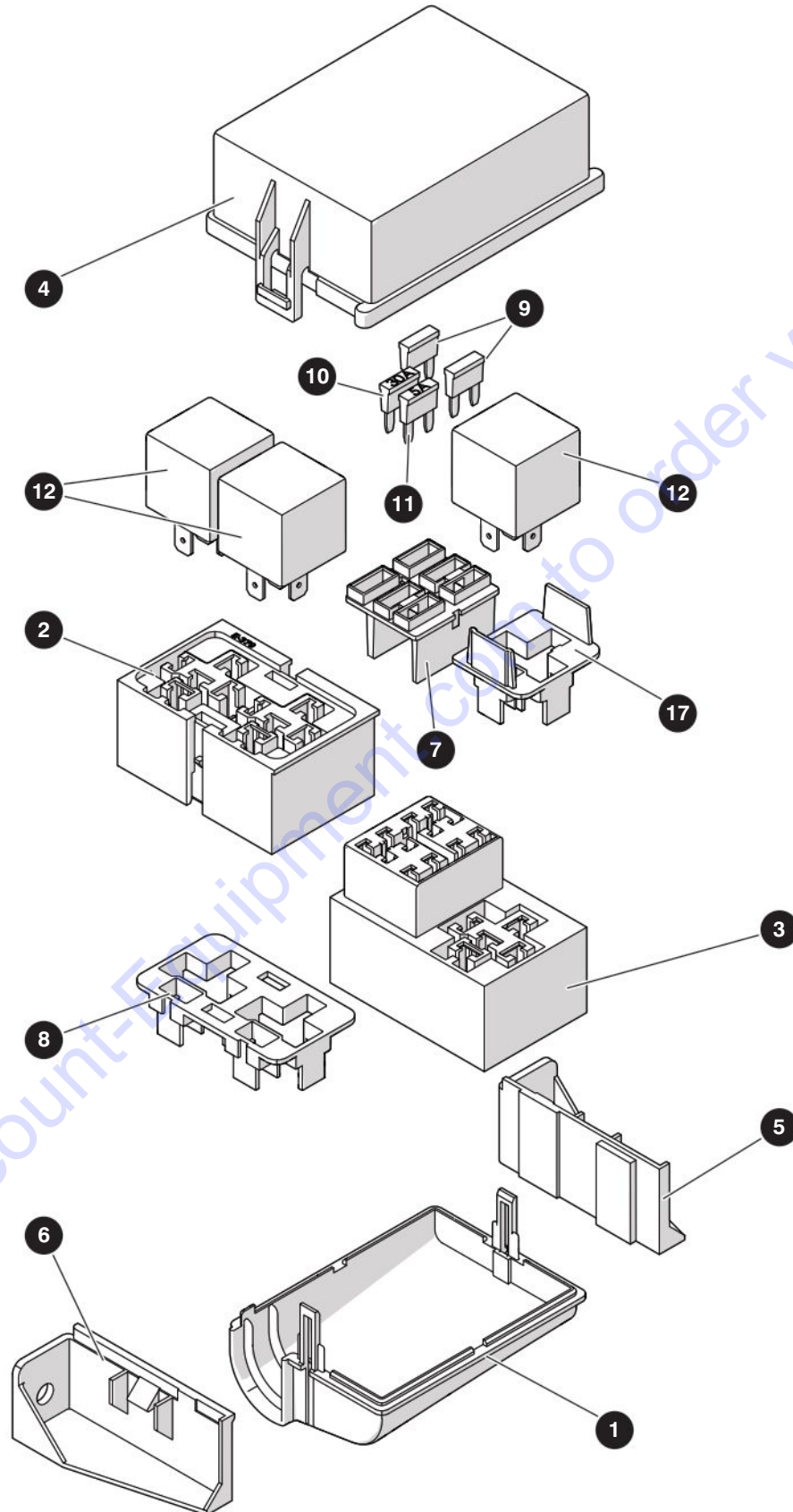

M236168AB

238271AAA

**160**

SJ45 AJ+

**SKYJACK**

## 7.3 Engine Fuse Box - Kubota D1305

Index No.	Skyjack Part No.	Qty.	Description
-	236168	1	FUSE BOX
1	198654	1	• COVER, Fuse box - bottom
2	198646	1	• BLOCK, Fuse box - dual ISO relay
3	198647	1	• BLOCK, Fuse box - ISO relay, 6 fuses
4	198651	1	• COVER, Fuse box - top
5	198652	1	• BRACKET, Fuse box - RH
6	198653	1	• BRACKET, Fuse box - LH
7	198649	1	• SPACER, Half module - mini fuse
8	198650	1	• SPACER, ISO relay
9	170626	2	• FUSE, ATM - 10A
10	198727	1	• FUSE, ATM - 30A
11	198725	1	• FUSE, ATM - 5A
12	127131	3	• RELAY, 12V 40 AMP
13	198657	4	• TERMINAL, Female - ISO relay (14/16 AWG) (not shown)
14	198658	4	• TERMINAL, Female - ISO relay (18/20 AWG) (not shown)
15	198662	1	• TERMINAL, Female - mini fuse (18/20 AWG) (not shown)
16	198661	5	• TERMINAL, Female - mini fuse (14/16 AWG) (not shown)
17	198648	1	• SPACER, Half module - ISO relay
18	198655	4	• TERMINAL, Female - ISO relay (10/12 AWG) (not shown)
19	198660	2	• TERMINAL, Female - mini fuse (10/12 AWG) (not shown)

## 7.4 Engine Harness - Kubota WG972

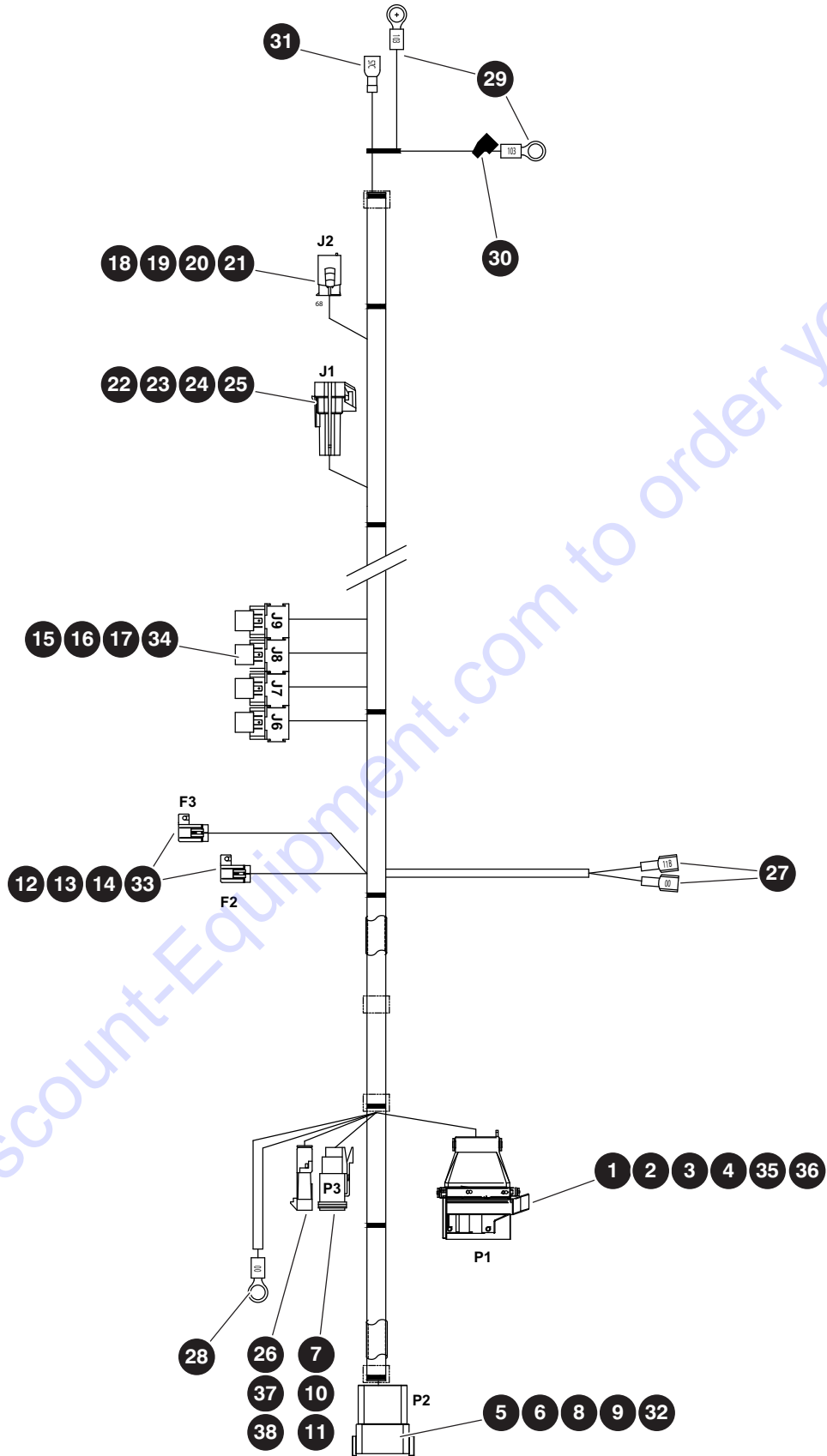

## 7.4 Engine Harness - Kubota WG972

Index No.	Skyjack Part No.	Qty.	Description
-	169377	1	ENGINE HARNESS - <b>Kubota WG972</b>
1	163675	1	• CONNECTOR (42M)
2	163676	11	• TERMINAL, Female (18 - 20 GA)
3	156173	4	• TERMINAL, Female (2.5 - 1.5 mm <sup>2</sup> )
4	156174	4	• TERMINAL, Female (1.0 - 0.5 mm <sup>2</sup> )
5	117586	1	• RECEPTACLE, Connector (12 pin)
6	117589	1	• CONNECTOR, Plug - wedge (12 pin)
7	117591	2	• SOCKET, Connector contact (16-18)
8	117592	3	• CONNECTOR, contact pin (14-16)
9	117594	5	• CONNECTOR, Sealing plug
10	117597	1	• CONNECTOR, Plug (2 PIN)
11	117599	1	• CONNECTOR, Plug - wedge (2 pin)
12	157850	2	• CONNECTOR, 2F Fuse holder
13	157851	4	• TERMINAL, Female (2.5 - 1.5 mm <sup>2</sup> )
14	156117	2	• COVER, Inline autofuse
15	138749	4	• SOCKET, Relay - automotive
16	126808	11	• TERMINAL, Female (14 - 18 GA)
17	163677	5	• TERMINAL, Female (12 - 16 GA)
18	141581	1	• CONNECTOR, 3 way socket
19	141582	1	• TERMINAL, Female (1.25 - 0.5 mm <sup>2</sup> )
20	142183	1	• SEAL, Wire (2.7 - 1.8 mm)
21	156167	2	• PLUG, Cavity
22	166481	1	• CONNECTOR, 4M, 150 M/P
23	163679	1	• TPA (4W)
24	163680	4	• TERMINAL, Male (0.8 - 0.5 mm <sup>2</sup> )
25	156146	4	• SEAL, Wire (2.9 - 2.0 mm)
26	156106	1	• CONNECTOR (1M)
27	114595	2	• TERMINAL, Female (18 - 22 AWG)
28	108172	1	• TERMINAL, Ring (10 - 12 GA x 3/8")
29	238222	1	• WIRE ASSEMBLY, Fuse link
30	117696	1	• TERMINAL, Boot
31	105359	1	• TERMINAL, Female (14 - 16 GA)
32	117590	4	• PIN, Connector contact (16-18)
33	156202	2	• FUSE (5A)
34	127131	4	• RELAY (12 V, 40 A)
35	166583	1	• BACKSHELL
36	166584	1	• SEAL, Inner
37	156116	1	• TERMINAL, Male (3.0 - 2.0 mm <sup>2</sup> )
38	157868	1	• SEAL, Wire (4.3 - 3.5 mm)
39	117590	4	• PIN, Connector contact (16-18)

## 7.5 ECU Power Harness - Kubota WG972

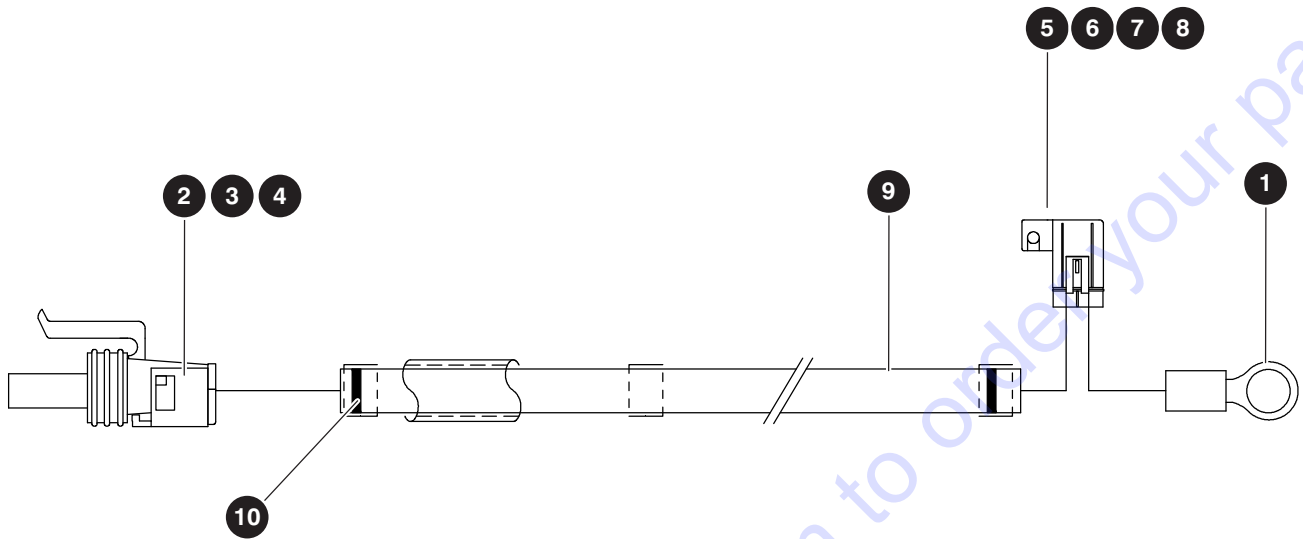

M166776AA

Index No.	Skyjack Part No.	Qty.	Description
-	166776	1	ECU POWER HARNESS
1	108172	1	• TERMINAL, Ring (10 - 12 GA, 3/8")
2	156108	1	• CONNECTOR, Female
3	156138	1	• TERMINAL, Female
4	157868	1	• SEAL, Wire
5	156127	1	• CONNECTOR, Female - Fuse holder
6	156118	2	• TERMINAL, Female
7	156117	1	• COVER, Inline autofuse
8	156164	1	• FUSE (30 A)
9	124399	183"	• PROTECTOR, Wire (1/4")
10	113719	2	• TIEWRAP (3 - 5/8")

## 7.6 Fuel Pump Harness - Kubota WG972

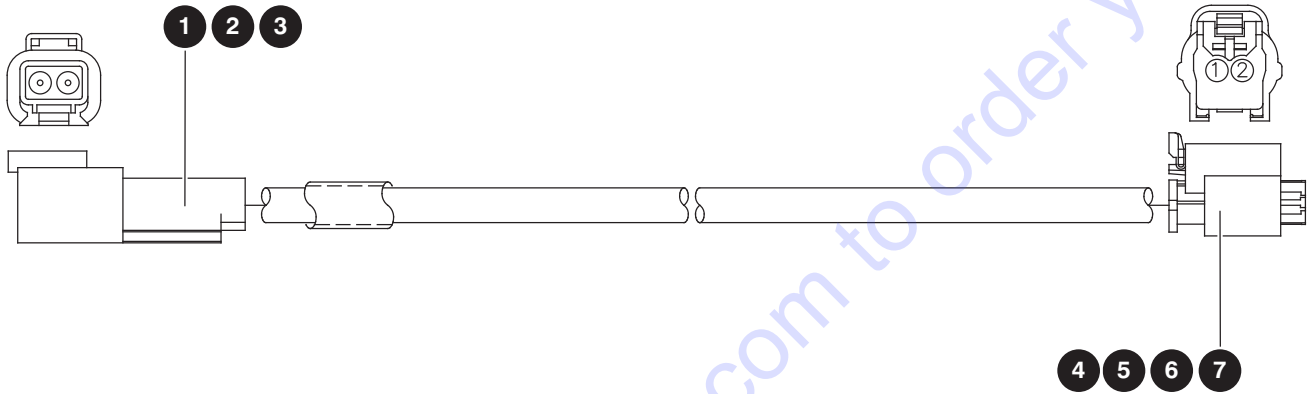

M238418AB

Index No.	Skyjack Part No.	Qty.	Description
-	238418	1	ECU POWER HARNESS
1	117596	1	• RECEPTACLE, Connector - deutsch 2 pin
2	117596	2	• PIN, Contact (16/18 GA)
3	117596	1	• WEDGE, Receptacle - deutsch 2 pin
4	117596	1	• CONNECTOR, 2 pole plug
5	117596	2	• SEAL, Wire - green (2-1.4 mm)
6	117596	1	• CONTACT, Female - automotive
7	117596	1	• PLATE, Connector 2P

## 7.7 Battery Cables

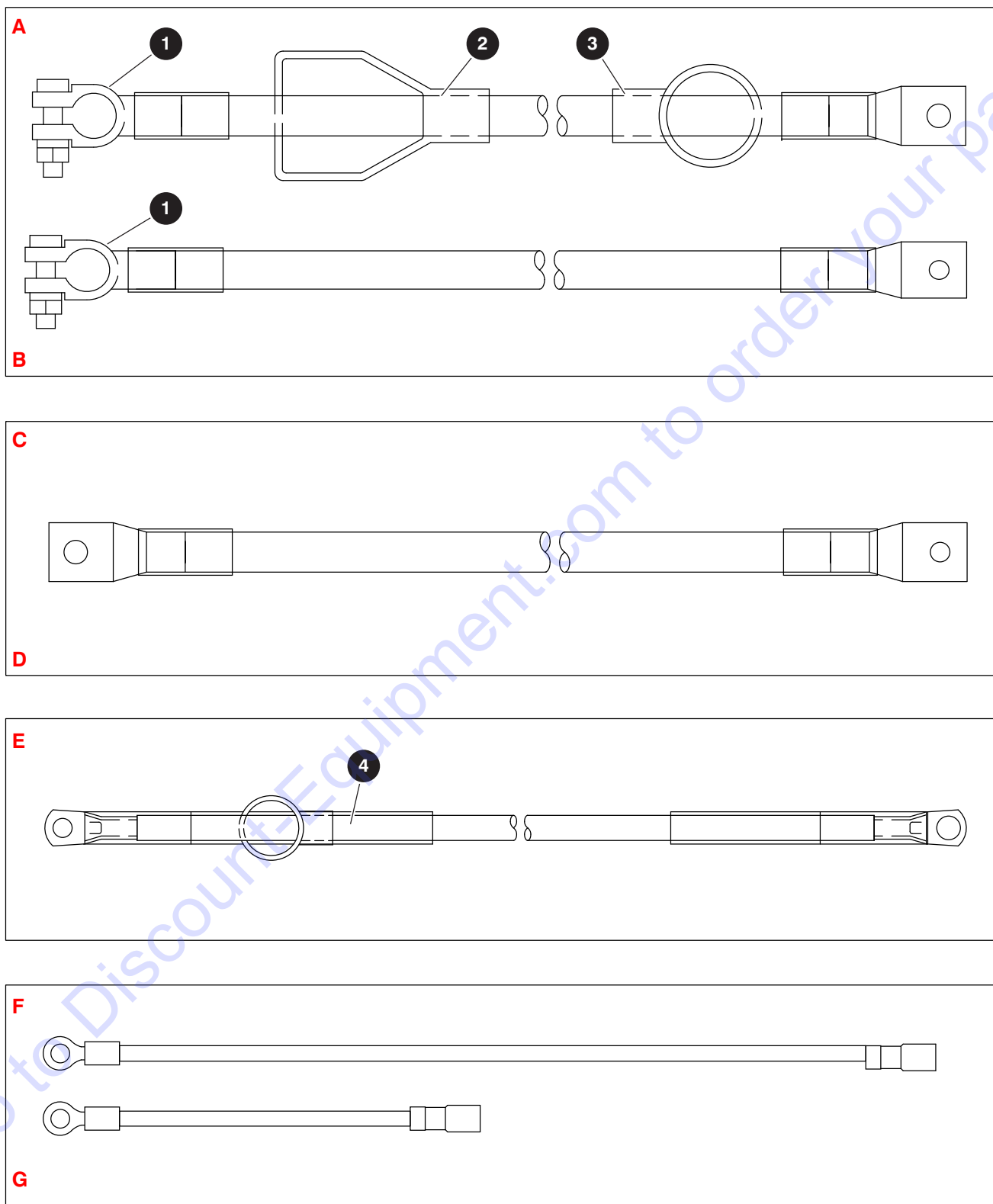

M167488AB1

238271AAA

SJ45 AJ+



## 7.7 Battery Cables

Index No.	Skyjack Part No.	Qty.	Description
<b>A</b>	138700	1	BATTERY CABLE (battery positive to battery disconnect)
<b>B</b>	238430	1	BATTERY CABLE (battery negative to turret ground)
<b>C</b>	238393	1	BATTERY CABLE (battery disconnect to starter)
<b>D</b>	238394	1	BATTERY CABLE (turret ground to starter)
<b>E</b>	138704	1	BATTERY CABLE (Emergency pump to battery disconnect)
<b>F</b>	152344	1	WIRE ASSEMBLY (Charge indicator, 00)
<b>G</b>	152345	1	WIRE ASSEMBLY (Charge indicator, 03)
1	139030	1	• POST CLAMP, Battery (#2/0 positive), <b>A</b>
	139031	1	• POST CLAMP, Battery (#2/0 negative), <b>B</b>
2	139032	1	• POST BOOT, Battery (#2/0 red), <b>A</b>
3	139105	1	• TERMINAL BOOT (#2/0 red), <b>A</b>
4	139106	1	• TERMINAL BOOT (#1 red), <b>D</b>

## 7.8 Control & CANbus Cables

---

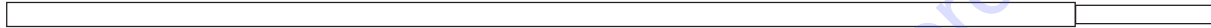

M218859AA

Index No.	Skyjack Part No.	Qty.	Description
1	218486	1	CONTROL CABLE (960")
2	218485	1	CANBUS CABLE (960")

## 7.9 Jib & Platform Rotate Valve Harnesses

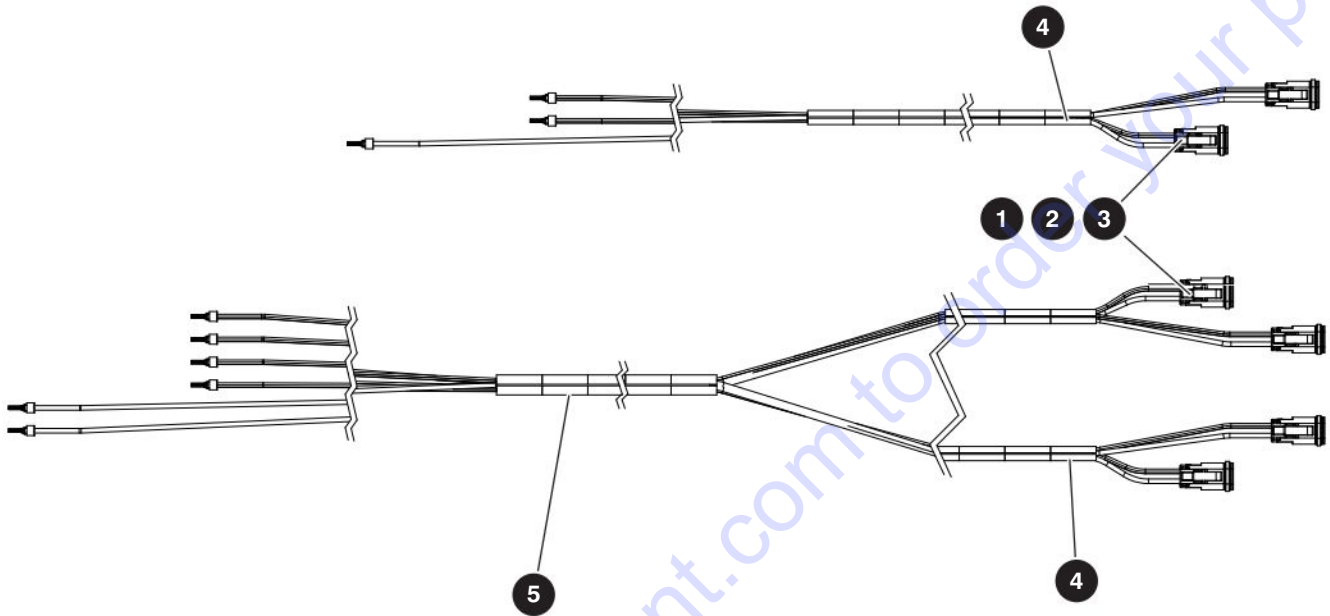

M167740AB\_M167698AB

Index No.	Skyjack Part No.	Qty.	Description
-	167698	1	HARNESS, Jib and platform rotate
1	117597	4	• CONNECTOR, Plug 2-pin
2	117599	4	• WEDGE, Connector plug 2-pin
3	117591	8	• SOCKET, Contact - connector plug 2-pin
4	124399	38"	• PROTECTOR, Wire (1/4")
5	111354	120"	• PROTECTOR, Wire (3/8")

# Section 8 – Hydraulic Hoses

**8.1** *Standard Hose Numbering System*

**8.2** *Boom Hoses*

**8.3** *Turret Hoses*

**8.4** *Base Hoses*

## 8.1 Standard Hose Numbering System

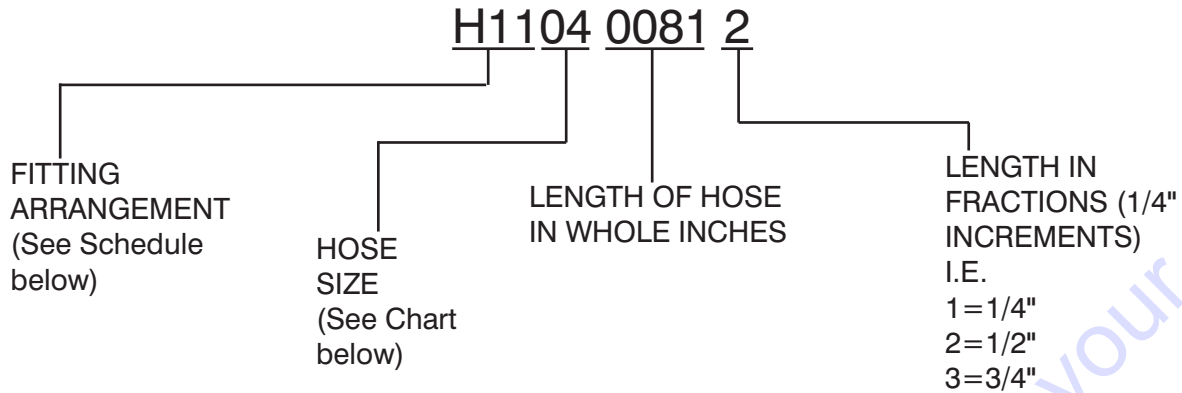

Using the number above as an example, H1104 0081 2, this hose requires a 37° JIC female swivel fitting on one end, and a medium length 90° JIC female swivel fitting for the other end. The hose must meet or exceed the S.A.E. 100R13 hose specification, and be a total of 81-1/2" long.



### NOTE

Hose ends and hose must be from same manufacturer per S.A.E. J1273 Nov. '91, Sections 3.10 and 4.2. Hose ends and hose must be of the same size i.e. #4 size fittings must be used with #4 size hose.

**Hose Size Chart**

Size	03	04	06	08	10	12	16	20	24	32	40	48	56	64
ID	3/16"	1/4"	3/8"	1/2"	5/8"	3/4"	1"	1-1/4"	1-1/2"	2"	2-1/2"	3"	3-1/2"	4"

**Fitting Arrangement Schedule**

Hose Prefix	Hose End Fitting	Hose End Fitting	S.A.E. Hose Specification
H01	FEMALE, 37° JIC, SWIVEL	FEMALE, 37° JIC, SWIVEL	100R17
H02	FEMALE, 37° JIC, SWIVEL	FEMALE, 37° JIC, SWIVEL	100R13
H03	FEMALE, 37° JIC, SWIVEL	45°, FEMALE, 37° JIC, SWIVEL	100R17
H04	FEMALE, 37° JIC, SWIVEL	45°, FEMALE, 37° JIC, SWIVEL	100R13
H05	FEMALE, 37° JIC, SWIVEL	LONG 90°, FEMALE, 37° JIC, SWIVEL	100R17
H06	FEMALE, 37° JIC, SWIVEL	SHORT 90°, FEMALE, 37° JIC, SWIVEL	100R17
H07	LONG 90°, FEMALE, 37° JIC, SWIVEL	LONG 90°, FEMALE, 37° JIC, SWIVEL	100R17
H08	FEMALE, 37° JIC, SWIVEL	FEMALE, 37° JIC, SWIVEL	100R4
H09	FEMALE, 37° JIC, SWIVEL	45°, FEMALE, 37° JIC, SWIVEL	100R4
H10	FEMALE, 37° JIC, SWIVEL	MALE PIPE THREAD FITTING	100R17
H11	FEMALE, 37° JIC, SWIVEL	MEDIUM 90°, FEMALE, 37° JIC, SWIVEL	100R13
H12	SHORT 90°, FEMALE, 37° JIC, SWIVEL	SHORT 90°, FEMALE, 37° JIC, SWIVEL	100R17
H13	FEMALE, 37° JIC, SWIVEL	REUSABLE MALE PIPE THREAD FITTING	300 PSI
H14	REUSABLE MALE PIPE THREAD FITTING	NO FITTING	300 PSI
H15	REUSABLE FEMALE, 37° JIC, SWIVEL	REUSABLE FEMALE, 37° JIC, SWIVEL	300 PSI
H16	NO FITTING	NO FITTING	100R4
H17	NO FITTING	NO FITTING	300 PSI
H18	REUSABLE, FEMALE, 37° JIC, SWIVEL	NO FITTING	300 PSI

## 8.1 Standard Hose Numbering System

Hose Prefix	Hose End Fitting	Hose End Fitting	S.A.E. Hose Specification
H19	LONG 90°, FEMALE, 37° JIC, SWIVEL	FEMALE, 37° JIC, SWIVEL	100R13
H20	FEMALE, SHORT 37° JIC, SWIVEL	SHORT 90°, FEMALE, 37° JIC, SWIVEL	100R4
H21	FEMALE, SHORT 37° JIC, SWIVEL	SHORT 90°, FEMALE, 37° JIC, SWIVEL	100R2AT
H22	FEMALE, 37° JIC, SWIVEL	FEMALE, 37° JIC, SWIVEL	100R2AT
H23	FEMALE, LONG 37° JIC, SWIVEL	LONG 90°, FEMALE, 37° JIC, SWIVEL	100R2AT
H24	FEMALE, SHORT 37° JIC, SWIVEL	SHORT 90°, FEMALE, 37° JIC, SWIVEL	100R13
H25	FEMALE, 37° JIC, SWIVEL	FEMALE, 37° JIC, SWIVEL	100R4
H30	MEDIUM 90°, FEMALE, 37° JIC, SWIVEL	FEMALE, 37° JIC, SWIVEL	100R17
H31	FEMALE, 37° JIC, SWIVEL	FEMALE, 37° JIC, SWIVEL	100R17
H32	SHORT 45°, FEMALE, 37° JIC, SWIVEL	FEMALE, 37° JIC, SWIVEL	100R17
H33	MEDIUM 45°, FEMALE, 37° JIC, SWIVEL	FEMALE, 37° JIC, SWIVEL	100R17
H34	SHORT 90°, FEMALE, 37° JIC, SWIVEL	FEMALE, 37° JIC, SWIVEL	100R17
H35	MEDIUM 90°, FEMALE, 37° JIC, SWIVEL	FEMALE, 37° JIC, SWIVEL	100R17
H36	LONG 90°, FEMALE, 37° JIC, SWIVEL	FEMALE, 37° JIC, SWIVEL	100R17
H37	SHORT 45°, FEMALE, 37° JIC, SWIVEL	FEMALE, 37° JIC, SWIVEL	100R4
H38	SHORT 90°, FEMALE, 37° JIC, SWIVEL	FEMALE, 37° JIC, SWIVEL	100R4
H39	LONG 90°, FEMALE, 37° JIC, SWIVEL	FEMALE, 37° JIC, SWIVEL	100R4
H40	SHORT 90°, FEMALE, 37° JIC, SWIVEL	FEMALE, 37° JIC, SWIVEL	100R16
H43	FEMALE, 37° JIC, SWIVEL	FEMALE, 37° JIC, SWIVEL	100R16
H51	FEMALE, 37° JIC, SWIVEL	FEMALE, 37° JIC, SWIVEL	100R17
H52	SHORT 45°, FEMALE, 37° JIC, SWIVEL	FEMALE, 37° JIC, SWIVEL	100R17
H53	MEDIUM 45°, FEMALE, 37° JIC, SWIVEL	FEMALE, 37° JIC, SWIVEL	100R17
H54	SHORT 90°, FEMALE, 37° JIC, SWIVEL	FEMALE, 37° JIC, SWIVEL	100R17
H55	MEDIUM 90°, FEMALE, 37° JIC, SWIVEL	FEMALE, 37° JIC, SWIVEL	100R17
H56	LONG 90°, FEMALE, 37° JIC, SWIVEL	FEMALE, 37° JIC, SWIVEL	100R17
H57	SHORT 45°, FEMALE, SAE ORFS, SWIVEL	FEMALE, SAE ORFS, SWIVEL	100R13
H58	FEMALE, SAE ORFS, SWIVEL	FEMALE, SAE ORFS, SWIVEL	100R13
H59	MEDIUM 90°, FEMALE, SAE ORFS, SWIVEL	FEMALE, SAE ORFS, SWIVEL	100R13
H60	FEMALE, 37° JIC, SWIVEL	FEMALE, 37° JIC, SWIVEL	100R17
H61	FEMALE, 37° JIC, SWIVEL	FEMALE, 37° JIC, SWIVEL	100R16
H62	SHORT 90°, FEMALE, 37° JIC, SWIVEL	FEMALE, 37° JIC, SWIVEL	100R16
H63	MEDIUM 90°, FEMALE, 37° JIC, SWIVEL	FEMALE, 37° JIC, SWIVEL	100R16
H64	LONG 90°, FEMALE, 37° JIC, SWIVEL	FEMALE, 37° JIC, SWIVEL	100R16
H65	MEDIUM 67°, FEMALE, 37° JIC, SWIVEL	FEMALE, 37° JIC, SWIVEL	100R12
H66	FEMALE, 37° JIC, SWIVEL	NO FITTING	100R4
H67	FEMALE, 37° JIC, SWIVEL	FEMALE, 37° JIC, SWIVEL	100R19
H68	SHORT 45°, FEMALE, 37° JIC, SWIVEL	FEMALE, 37° JIC, SWIVEL	100R19
H69	MEDIUM 90°, FEMALE, 37° JIC, SWIVEL	FEMALE, 37° JIC, SWIVEL	100R19
H70	LONG 90°, FEMALE, 37° JIC, SWIVEL	FEMALE, 37° JIC, SWIVEL	100R19
H71	LONG 90°, FEMALE, SAE ORFS, SWIVEL	FEMALE, SAE ORFS, SWIVEL	100R15

## 8.2 Boom Hoses

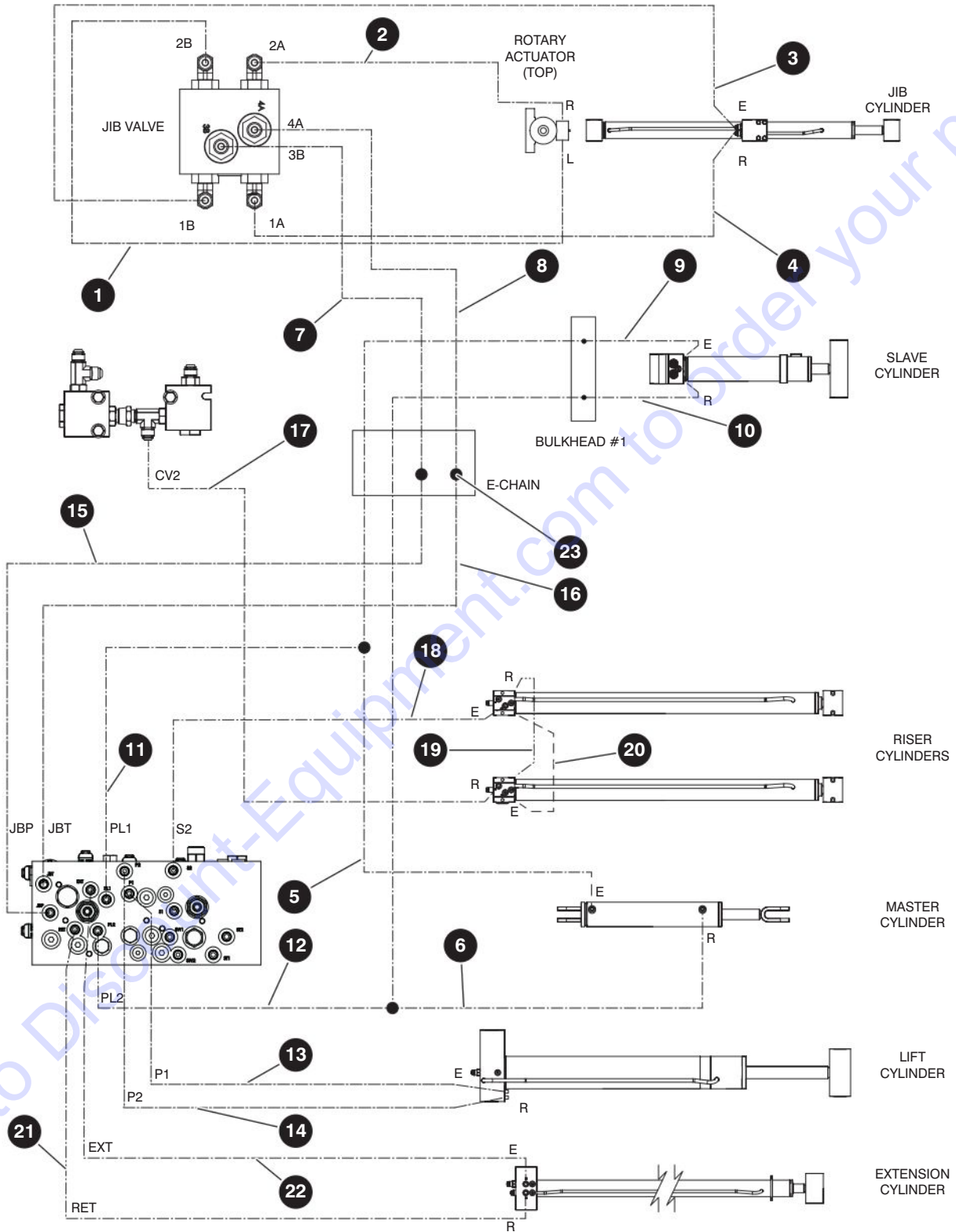

M218924AA\_M149104AG\_M149103AF

238271AAA

174

SJ45 AJ+

SKYJACK

## 8.2 Boom Hoses

Index No.	Hose P/N	From		To	
		Description	Port	Port	Description
-	218924	JIB HOSE KIT			
1	H3104 0096 0	Jib Manifold	2B	L	Rotart Actuator
2	H3104 0102 0	Jib Manifold	2A	R	Rotart Actuator
3	H3104 0077 0	Jib Manifold	1B	E	Jib Cylinder
4	H3104 0077 0	Jib Manifold	1A	R	Jib Cylinder
-	218929	BOOM HOSE KIT			
5	H3104 0219 0	Master Cylinder	E	-	Bulkhead 1 (Fly Boom)
6	H3104 0230 0	Master Cylinder	R	-	Bulkhead 1 (Fly Boom)
7	H3104 0210 0	Jib Manifold	3B	-	Union
8	H3104 0210 0	Jib Manifold	4A	-	Union
9	H3104 0028 2	Slave Cylinder	E	-	Bulkhead 1 (Fly Boom)
10	H3104 0028 2	Slave Cylinder	R	-	Bulkhead 1 (Fly Boom)
-	149103	RISER HOSE KIT			
11	H3104 0380 0	Main Manifold	PL1	E	Master Cylinder
12	H3104 0360 0	Main Manifold	PL2	R	Master Cylinder
13	H3104 0380 0	Main Manifold	P1	E	Boom Lift Cylinder
14	H3104 0374 0	Main Manifold	P2	R	Boom Lift Cylinder
15	H3104 0392 0	Main Manifold	JBP	-	Union
16	H3104 0392 0	Main Manifold	JBT	-	Union
17	H3206 0144 0	Check Valve	CV2	E	Riser Cylinder - RH
18	H3104 0144 0	Main Manifold	S2	R	Riser Cylinder - LH
19	H3106 0031 0	Riser Cylinder LH - Return	R	R	Riser Cylinder RH - Return
20	H3106 0031 0	Riser Cylinder LH - Return	E	E	Riser Cylinder RH - Return
21	H3106 0346 0	Main Manifold	RET	R	Extension Cylinder
22	H3106 0346 0	Main Manifold	EXT	E	Extension Cylinder
Index No.	Skyjack Part No.	Qty.	Description		
23	134835	2	FITTING, Straight (04 JICM - 04 JICM) (component of Riser Hose Kit)		
24	131732	48"	SLEEVE, Nylon hose protection (componen of E-Chain Hose Kit) (not shown)		
25	126128	2	FITTING (4 SAE - 04 JIC) (not shown)		



# 8.3 Turret Hoses

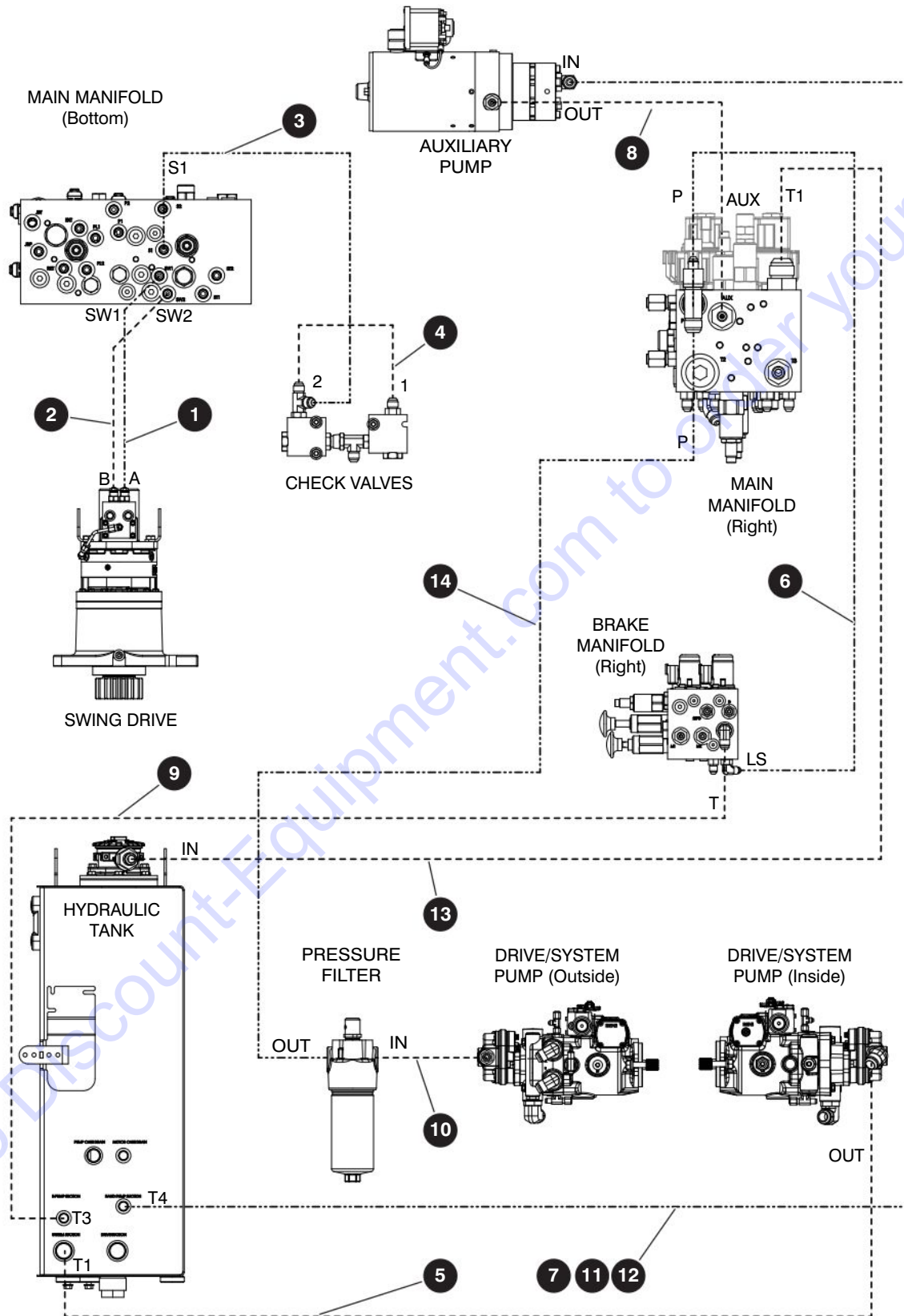

M211209AA\_M166841AA

238271AAA

## 8.3 Turret Hoses

Index No.	Hose P/N	From		To	
		Description	Port	Port	Description
-	238506	TURRET HOSE KIT			
1	H3404 0078 0	Main Manifold	SW1	A	Swing Drive
2	H3404 0078 0	Main Manifold	SW2	B	Swing Drive
3	H3206 0012 2	Main Manifold	S1	2	Check Valve
4	H3106 0016 0	Check Valve	1	2	Check Valve
-	237589	SYSTEM & AUXILIARY PUMP HOSE KIT			
5	H3916 0063 0	System Pump (Suction)	OUT	T1	Hydraulic Tank
6	H3204 0042 0	Main Manifold	P	LS	Brake Manifold
7	H1708 0007 0	Hydraulic Tank (H.P. Suction)	T4	IN	Auxiliary Pump
8	H3404 0034 0	Auxiliary Pump	OUT	AUX	Main Manifold
9	H5106 0018 0	Brake Manifold	T	T3	Main Manifold
10	H5410 0025 0	Pressure Filter	IN	-	System Pump
11	144087	Straight Fitting (08 BARB - 08 JICFS)			
12	144094	Hose Clamp (19-21 Mikalor)			
-	166752	NO OIL COOLER HOSE KIT			
13	H5112 0030 0	Return Filter	IN	T1	Main Manifold
14	H5108 0086 0	Pressure Filter	OUT	P	Main Manifold

# 8.4 Base Hoses

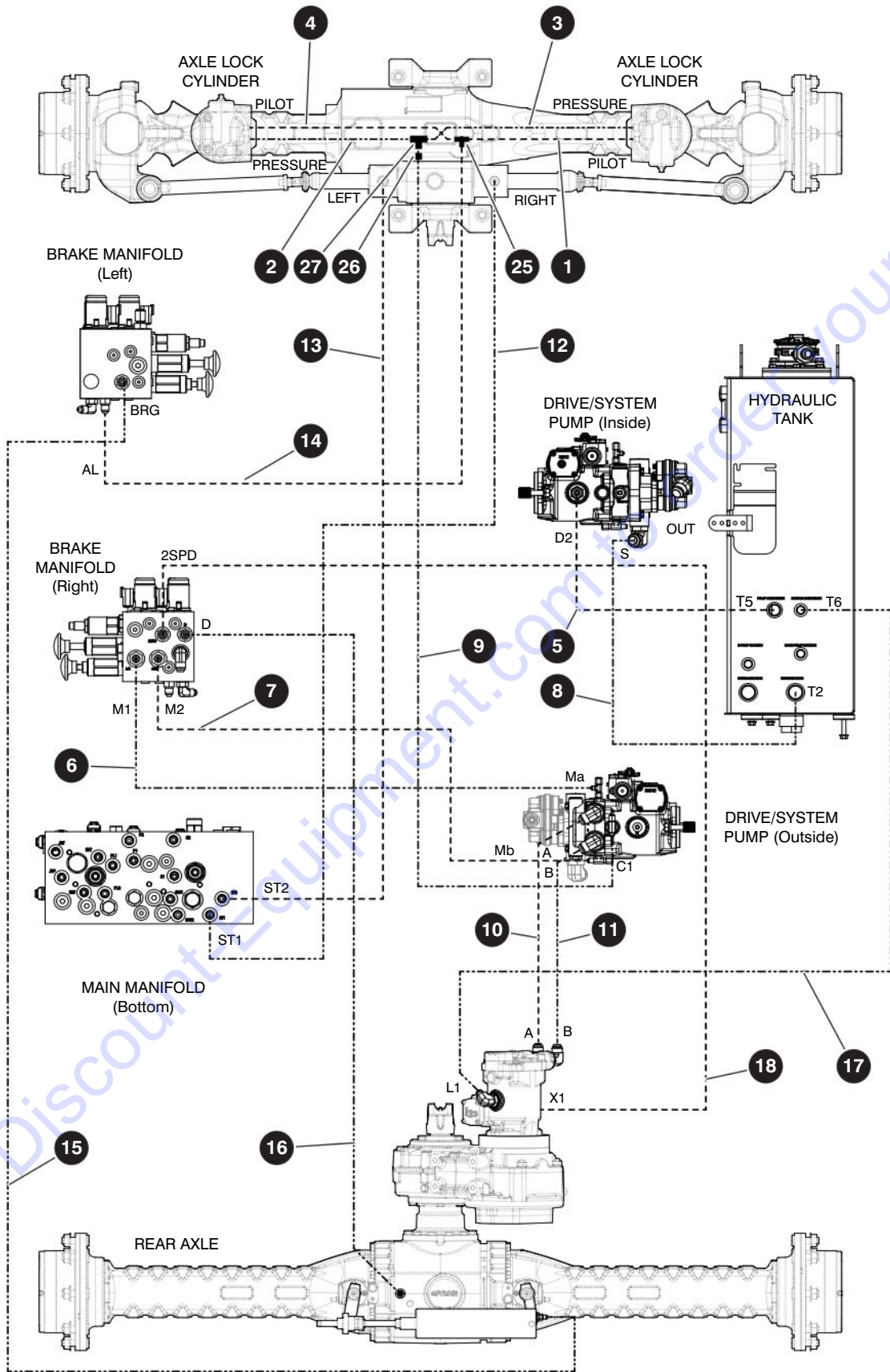

M238506AC\_M237588AC

238271AAA

## 8.4 Base Hoses

Index No.	Hose P/N	From		To	
		Description	Port	Port	Description
-	211212	CHASSIS HOSE KIT			
1	H3104 0031 0	Axle Lock - Pilot Right	-	-	Axle Lock - Pilot Tee
2	H3106 0031 0	Axle Lock - Pressure Left	-	-	Axle Lock - Pressure Tee
3	H3106 0031 0	Axle Lock - Pressure Right	-	-	Axle Lock - Pressure Tee
4	H3104 0031 0	Axle Lock - Pilot Left	-	-	Axle Lock - Pilot Tee
-	237588	DRIVE PUMP HOSE KIT			
5	H3812 0077 0	Drive Pump	D2	T5	Hydraulic Tank (P. Case Drain)
6	H4004 0080 0	Drive Pump	Ma	M1	Brake Manifold
7	H4004 0080 0	Drive Pump	Mb	M2	Brake Manifold
8	H3816 0056 0	Drive Pump	S	T2	Hydraulic Tank (Drive Suction)
9	H3104 0129 0	Drive Pump	C1	-	Axle Lock - Pressure Tee
10	H0212 0177 0	Drive Pump	A	A	Drive Motor
11	H0212 0177 0	Drive Pump	B	B	Drive Motor
-	238506	TURRET HOSE KIT (with hoses from 8.3)			
12	H3204 0144 0	Steering Cylinder	R	ST1	Main Manifold
13	H3204 0144 0	Steering Cylinder	L	ST2	Main Manifold
14	H3404 0127 0	Axle Lock - Pilot Tee	-	AL	Brake Manifold
15	H3404 0173 0	Rear Axle - Brake	-	BRG	Brake Manifold
16	H3404 0171 0	Rear Axle - Diff Lock	-	D	Brake Manifold
17	H3108 01420	Motor	L1	T6	Hydraulic Tank
18	H3404 0135 0	Motor	X1	2SPD	Brake Manifold
Index No.	Skyjack Part No.	Qty.	Description		
19	140914	140"	SLEEVE, Nylon (part of drive pump hose kit)		
20	140914	140"	SLEEVE, Nylon (part of drive pump hose kit)		
21	131732	24"	SLEEVE, Nylon (part of drive pump hose kit)		
22	131732	19"	SLEEVE, Nylon (part of drive pump hose kit)		
23	131732	13"	SLEEVE, Nylon (part of drive pump hose kit)		
24	131732	13"	SLEEVE, Nylon (part of turret hose kit)		
25	131697	1	FITTING, Tee (04 JICM - 04 JICM - 04 JICM)		
26	707041	1	FITTING, Straight (06 JICF - 04 JICM)		
27	131704	1	FITTING, Tee (06 JICM - 06 JICM - 06 JICM)		

## Section 9 – Optional Equipment

**9.1** *Flashing Light*

**9.2** *Oil Quick Drain*

**9.3** *Welder & Mount*

**9.4** *Glazier Tray*

**9.5** *Control Box Cover*

**9.6** *Pipe Rack*

**9.7** *Tool Caddy*

**9.8** *Half-Height Platform Mesh*

**9.9** *External Railing*

**9.10** *Elevate Telematics*

**9.11** *Elevate Telematics Subscription*

## 9.1 Flashing Light

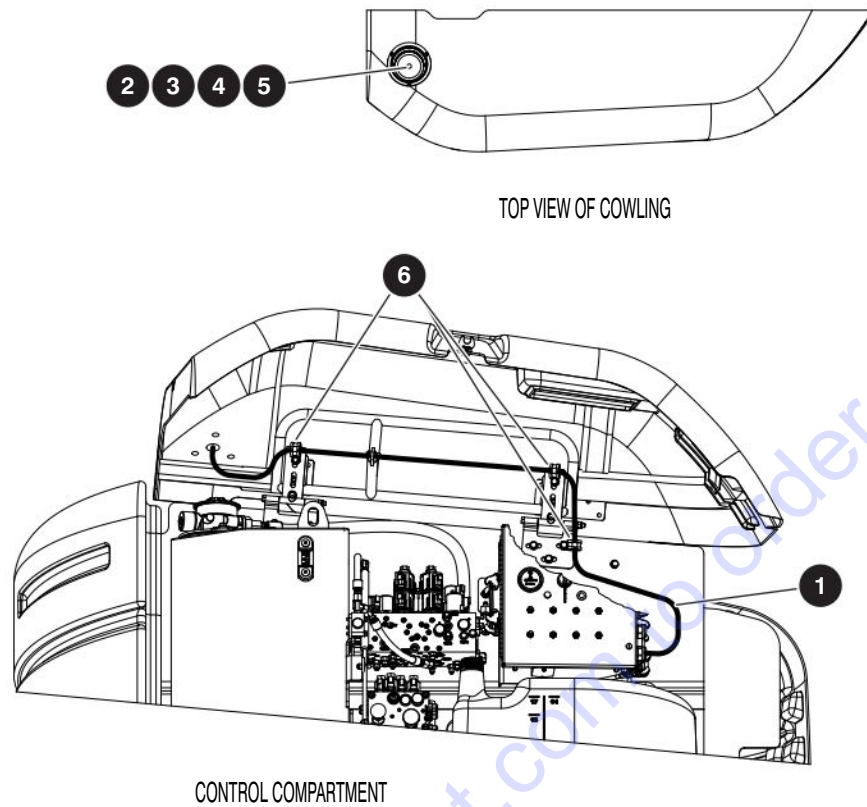

M148528AA

Index No.	Skyjack Part No.	Qty.	Description
-	148528	1	FLASHING AMBER LIGHT OPTION
1	152585	1	• HARNESS, Flash amber light
	117591	2	• • CONNECTOR, Contact socket (16/18 GA)
	117599	1	• • CONNECTOR, Wedge (2 pin)
	117597	1	• • CONNECTOR (2 pin)
2	144078	1	• FLASHING AMBER LIGHT ASSEMBLY
	143971	1	• • STROBE LIGHT, Amber (12/24 VDC)
	144215	1	• • • FLASH TUBE
	117596	1	• • CONNECTOR, Receptacle (2 pin)
	117590	2	• • CONNECTOR, Contact pin (16/18 GA)
	117598	1	• • WEDGE, Receptacle (2 pin)
	124399	4"	• • SPLIT LOOM (1/4")
3	122498	3	• SCREW, Round head machine (#10-32 x 1 1/4")
4	300450	3	• LOCKNUT, Hex (#10-32 UNF, nylon insulated)
5	104694	3	• WASHER, Flat (#10 SAE)
6	102972	3	• CLIP, Double (G8)

238271AAA

SJ45 AJ+

## 9.2 Oil Quick Drain

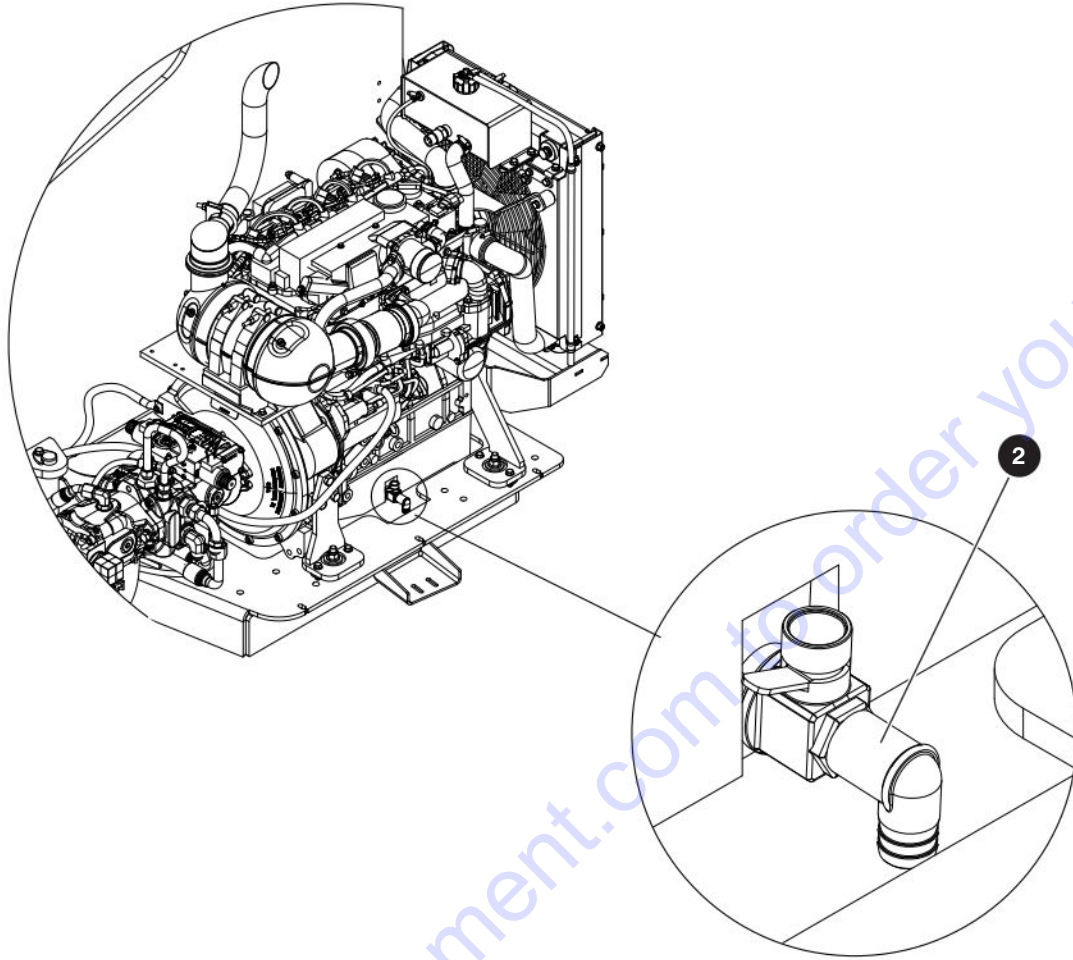

M169469AA

Index No.	Skyjack Part No.	Qty.	Description
-	171265	1	OIL QUICK DRAIN
1	170731	1	<ul style="list-style-type: none"> <li>VALVE, Oil drain</li> </ul>

## 9.3 Welder & Mount

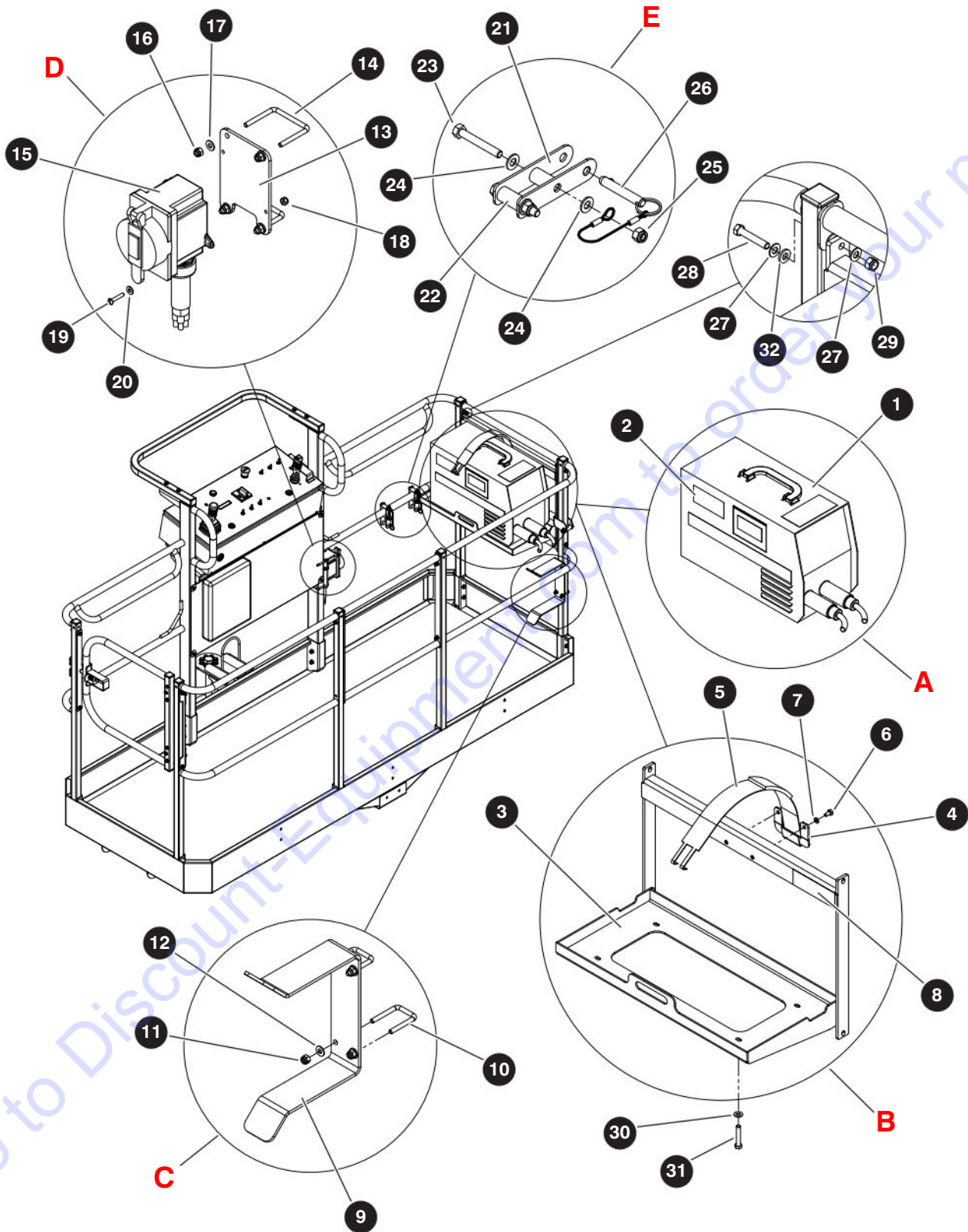

M159917AD

238271AAA

184

SJ45 AJ+

SKYJACK



## 9.3 Welder & Mount

Index No.	Skyjack Part No.	Qty.	Description
<b>A</b> 1	148383	1	WELDER ASSEMBLY - <b>12 kW generator</b>
	138811	1	• WELDER (275A)
	138813	1	• CABLE, Electrode (14')
	144376	1	• • ELECTRODE HOLDER (400A)
	144573	168"	• • CABLE
	138814	1	• CABLE, Work (14')
	144377	1	• • GROUND CLAMP (400A)
	144573	168"	• • CABLE
	144374	1	• PLUG, Locking (50A / 250V / 3P)
	144603	2	• CLAMP, Cushioned loop (0.875" diameter)
2	147112	1	• LABEL, Welder weight (90 lbs)
-	159917	1	MOUNTING ASSEMBLY, 12kW Welder
<b>B</b> 3 4 5 6 7 8	159948	1	• WELDER TRAY ASSEMBLY
	159955	1	• • TRAY, Welder
	137814	1	• • PLATE, Strap
	103020	1	• • STRAPS (pair)
	103855	2	• • BOLT, Hex head (1/4"-20 x 0.50", Grade 5)
	104000	2	• • WASHER, Lock (1/4")
	147112	1	• • LABEL, Welder weight (90 lbs)
	<b>C</b> 9 10 11 12	144218	1
144220		1	• • BRACKET, Welding cables
144219		2	• • U BOLT, Welder bracket
115649		4	• • NUT, Hex lock (1/4"-20 Grade 5, nylon)
103995		4	• • WASHER, Flat (1/4")
<b>D</b> 13 14 15 16 17 18 19 20	144221	1	• RECEPTACLE ASSEMBLY
	144222	1	• • PLATE, Receptacle mounting
	144223	2	• • U BOLT, Receptacle mounting
	141614	1	• • ELECTRICAL COMPONENTS ASSEMBLY
	139835	1	• • • FD BOX, 50A Receptacle
	139832	1	• • • RECEPTACLE, Single locking
	139836	1	• • • COVER, Weather resistant
	144367	1	• • • STRAIN RELIEF, 1-18" straight
	115649	4	• • NUT, Hex lock (1/4"-20 Grade 5, nylon)
	103995	4	• • WASHER, Flat (1/4")
	300450	2	• • NUT, Hex lock (#10-32 Grade 5, nylon)
	105621	2	• • SCREW, Round head machine (#10-32 x 1")
104694	2	• • WASHER, Flat (#10)	

## 9.3 Welder & Mount

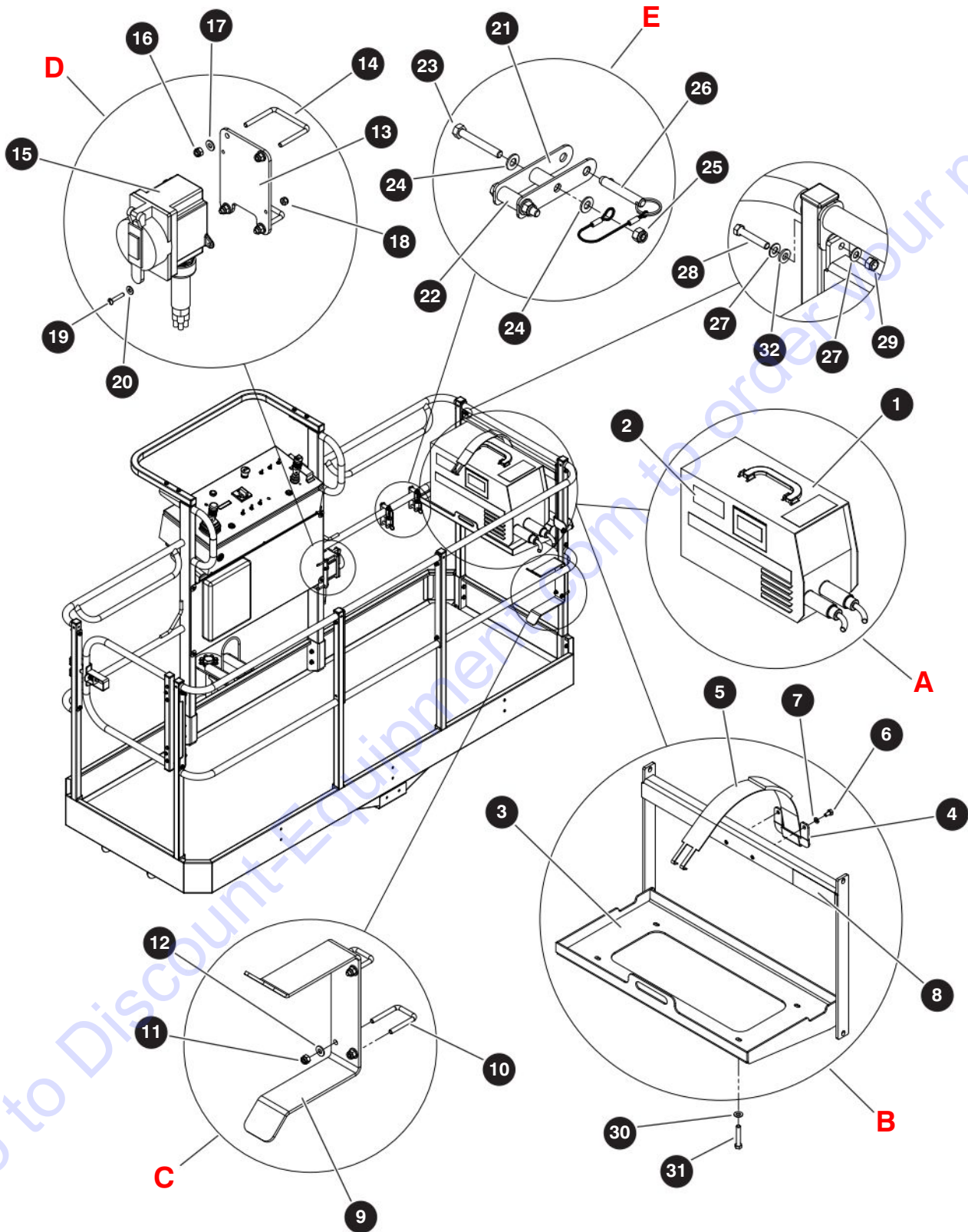

M159917AD

238271AAA

186

SJ45 AJ+

SKYJACK

## 9.3 Welder & Mount

Index No.	Skyjack Part No.	Qty.	Description
<b>E</b>	168530	2	• HANGER ASSEMBLY
21	169160	2	• • BRACKET, Welder cable
22	159947	2	• • SPACER, Welder tray
23	103866	2	• • BOLT, Hex head (5/16"-18 x 2 1/4 Grade 5)
24	103996	4	• • WASHER, Flat (5/16")
25	103984	2	• • NUT, Hex lock nylon lock (5/16"-18 Grade 5)
26	124548	1	• • PIN, Quick release
27	103996	8	• WASHER, Flat (5/16")
28	103884	4	• BOLT, Hex head (5/16"-18 x 2.50", Grade 5)
29	103984	4	• NUT, Hex head nylon lock (5/16"-18, Grade 5)
30	103995	4	• WASHER, Flat (1/4")
31	103857	4	• BOLT, Hex head (1/4"-20 x 1.00" Grade 5)
32	159960	2	• SPACER, Nylon (0.403" ID x 0.75" OD, x 0.312" long) (drop bar entrance)
	168336	2	• SPACER, Nylon (0.394" ID x 0.75" OD, x 0.125" long)

## 9.4 Glazier Tray

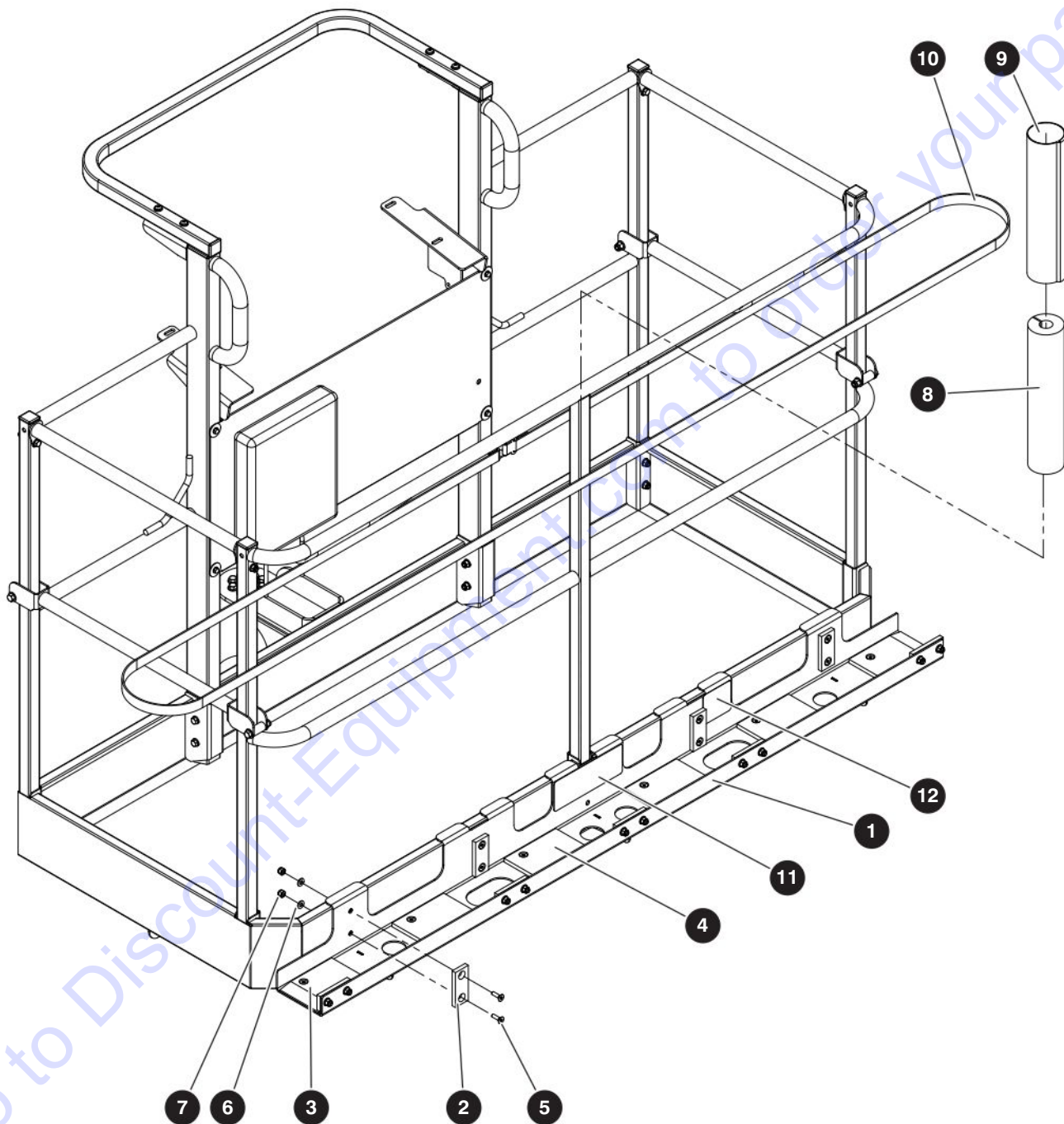

M169156AC

238271AAA

SJ45 AJ+

## 9.4 Glazier Tray

Index No.	Skyjack Part No.	Qty.	Description
-	169156	1	GLAZIER FIELD KIT
-	169157	1	• GLAZIER PACKAGE ASSEMBLY
-	169158	1	• • GLAZIER TRAY ASSEMBLY
1	154402	1	• • • TRAY WELDMENT, Glazier
2	154401	9	• • • PAD, Side tray
3	154399	2	• • • PAD, End tray
4	154400	4	• • • PAD, In tray
5	162116	30	• • • BOLT, Flat head cap screw (5/16"-18 x 1.00", Grade 5)
6	103996	30	• • • WASHER, Flat (5/16")
7	103984	30	• • • NUT, Hex head nylon lock (5/16-18, Grade 5)
8	144491	1	• • FOAM, Support
9	144604	1	• • COVER, Bumper
10	144613	1	• • STRAP, Glazier kit
11	172630	1	• • LABEL, Panel cradle capacity
12	171238	1	• • LABEL, Panel option weight
13	162026	1	• INSTRUCTION, Glazier package operation and installation (not shown)

## 9.5 Control Box Cover

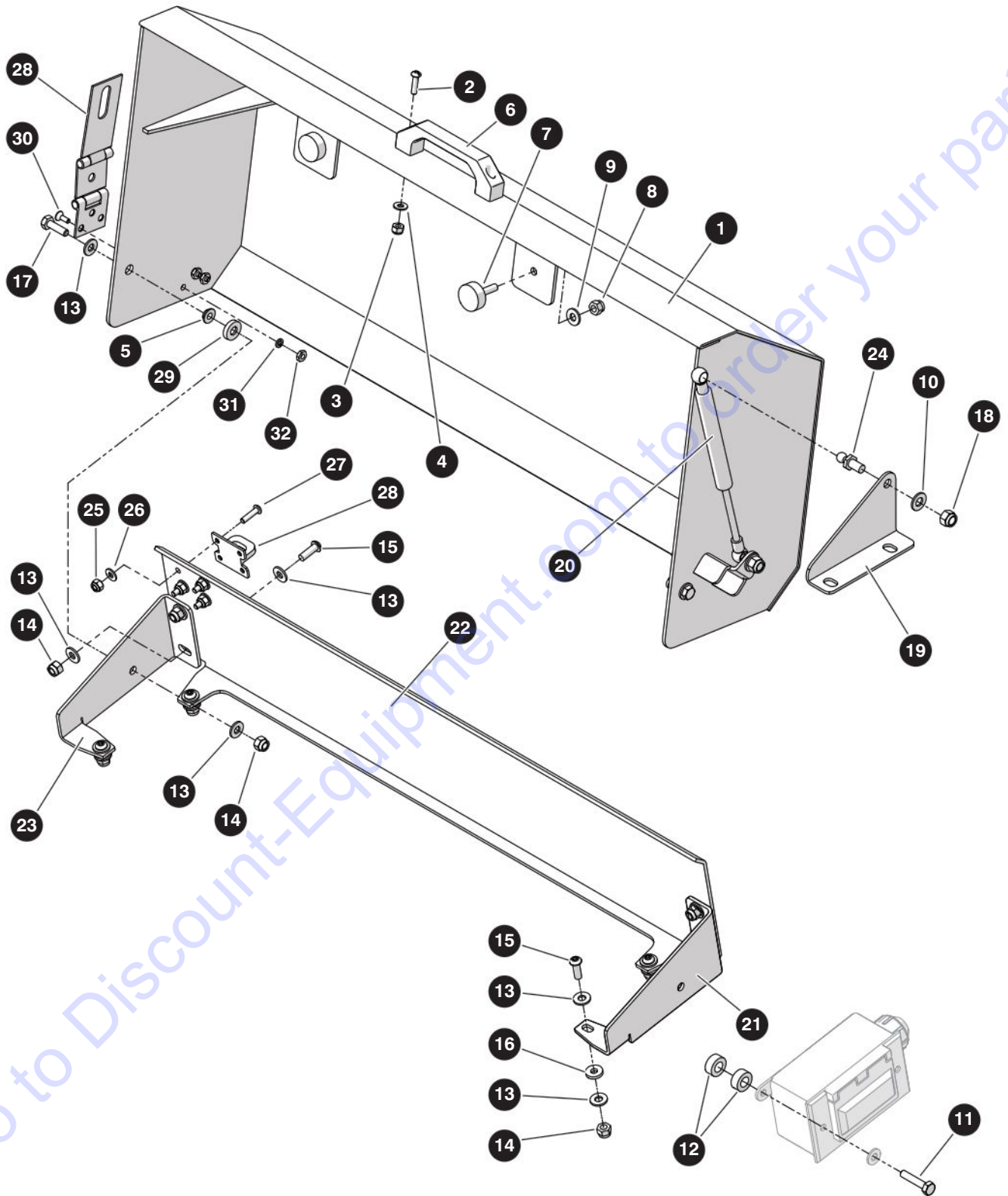

M216819AA

238271AAA

## 9.5 Control Box Cover

Index No.	Skyjack Part No.	Qty.	Description
-	216918	1	CONTROL BOX COVER
-	216917	1	• COVER ASSEMBLY, Control box
1	216919	1	• • COVER, Control box
2	104698	2	• • SCREW, Round machine (#10-32 x 1")
3	300450	2	• • NUT, Hex lock (#10-32 Grade 5, nylon)
4	104694	2	• • WASHER, Flat (#10)
5	154305	2	• • BUSHING, Flanged (0.25" ID x 0.1875")
6	137653	1	• • HANDLE, Pull
7	144015	2	• • MOUNT, Anti-vibration
8	115649	2	• • NUT, Hex lock (0.25"-20 Grade 5, nylon)
9	103995	2	• • WASHER, Flat (0.25")
10	103996	2	• WASHER, Flat (0.3125")
11	103858	2	• BOLT, Hex head (0.25"-20 x 1.25" Grade 5)
12	159960	4	• SPACER, (0.75" OD)
13	103995	16	• WASHER, Flat (0.25")
14	115649	10	• NUT, Hex lock (0.25"-20 Grade 5, nylon)
15	139168	8	• SCREW, Button head cap (0.25"-20 x 0.75")
16	159956	4	• WASHER, Rubber (0.25")
17	103891	2	• BOLT, Hex head (0.25"-20 x 0.875" Grade 5)
18	103984	2	• NUT, Hex lock (0.3125"-18 Grade 5, nylon)
19	154323	1	• BRACKET, Gas spring
20	162101	1	• GAS SPRING, Control box cover
21	162048	1	• PLATE, Right side cover
22	216921	1	• PLATE, Back cover
23	162049	1	• PLATE, Left side cover
24	162123	2	• STUD, Ball (10 mm x 0.54")
25	300450	4	• NUT, Hex head nylon lock (10-32, Grade 5)
26	104694	4	• WASHER, Flat (10)
27	104698	4	• SCREW, Round head machine (10-32 x 0.75")
28	216675	1	• HASP, Double hinge (3.25")
29	168336	3	• SPACER, Nylon (0.394" ID x 0.75" OD x 0.125" long)
30	124031	3	• SCREW, Flat head (10-32 x 0.50")
31	104185	3	• WASHER, Lock (10)
32	104003	3	• NUT, Hex (10-32)
33	162032	1	• INSTRUCTION, Control box cover installation (not shown)

## 9.6 Pipe Rack

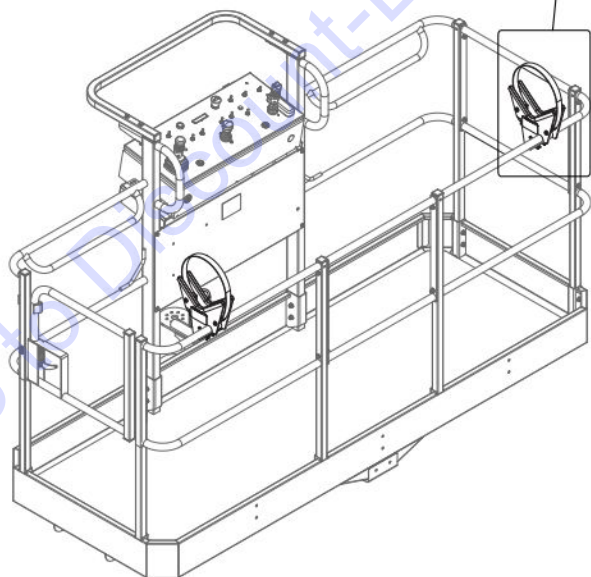
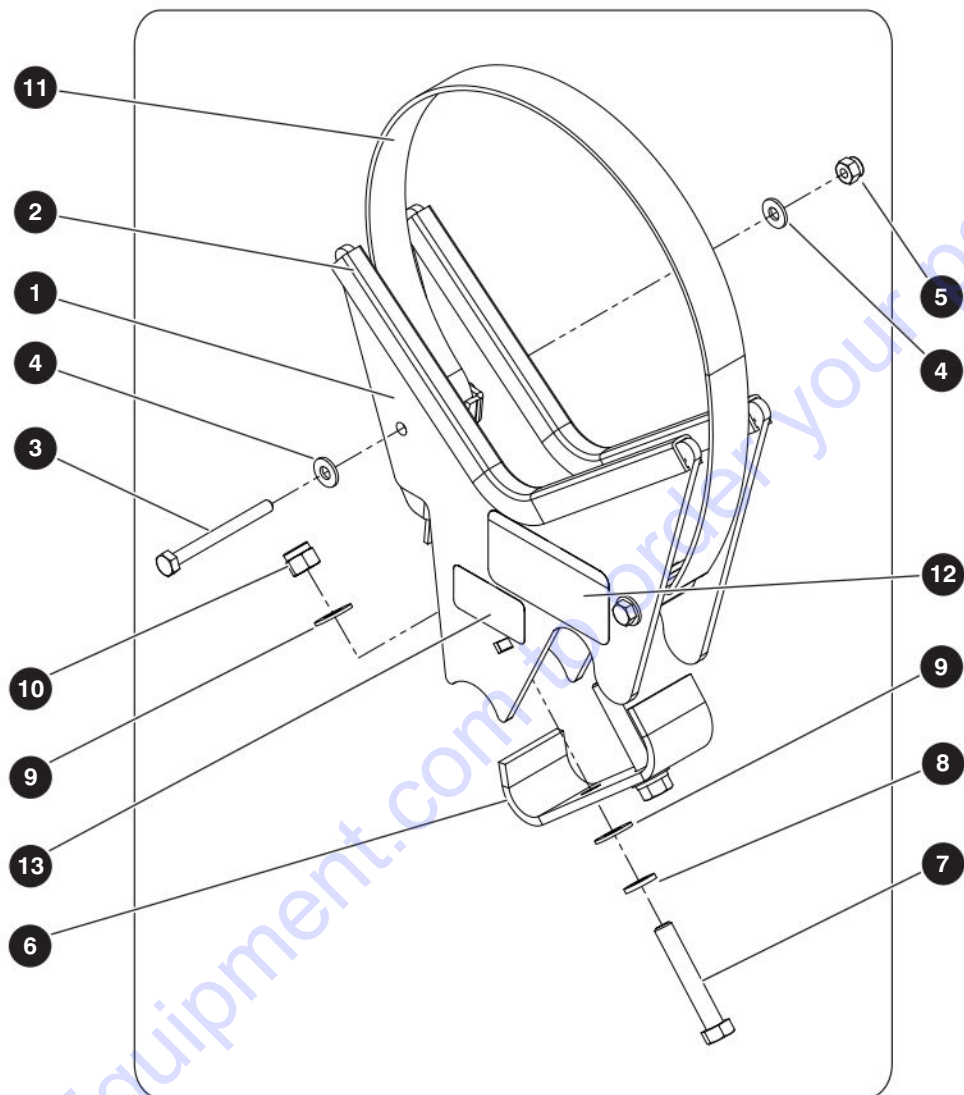

M162052AD

238271AAA

SJ45 AJ+



## 9.6 Pipe Rack

Index No.	Skyjack Part No.	Qty.	Description
-	148559	1	PIPE RACK
-	149112	1	• PIPE RACK ASSEMBLY
1	144495	1	• • WELDMENT, PIPE RACK
2	117398	48"	• • TRIM, Protective
3	144501	4	• • BOLT, Hex head (0.25"-20 x 2.75", Grade 5)
4	103995	8	• • WASHER, Flat (0.25")
5	115649	4	• • NUT, Hex head nylon lock (0.25"-20, Grade 5)
6	144499	2	• • PLATE, Pipe rack bottom
7	103872	4	• • BOLT, Hex head (0.375"-16 x 2.25", Grade 5)
8	103999	4	• • WASHER, Lock (0.375")
9	103472	4	• • WASHER, Flat (0.375")
10	104606	2	• • NUT, Hex head nylon lock (0.375"-16)
11	144500	2	• • STRAP, Pipe rack
12	172383	2	• • LABEL, Pipe rack capacity
13	171239	2	• • LABEL, Capacity reduction
14	162725	1	• INSTRUCTION, Pipe rack installation (not shown)

## 9.7 Tool Caddy

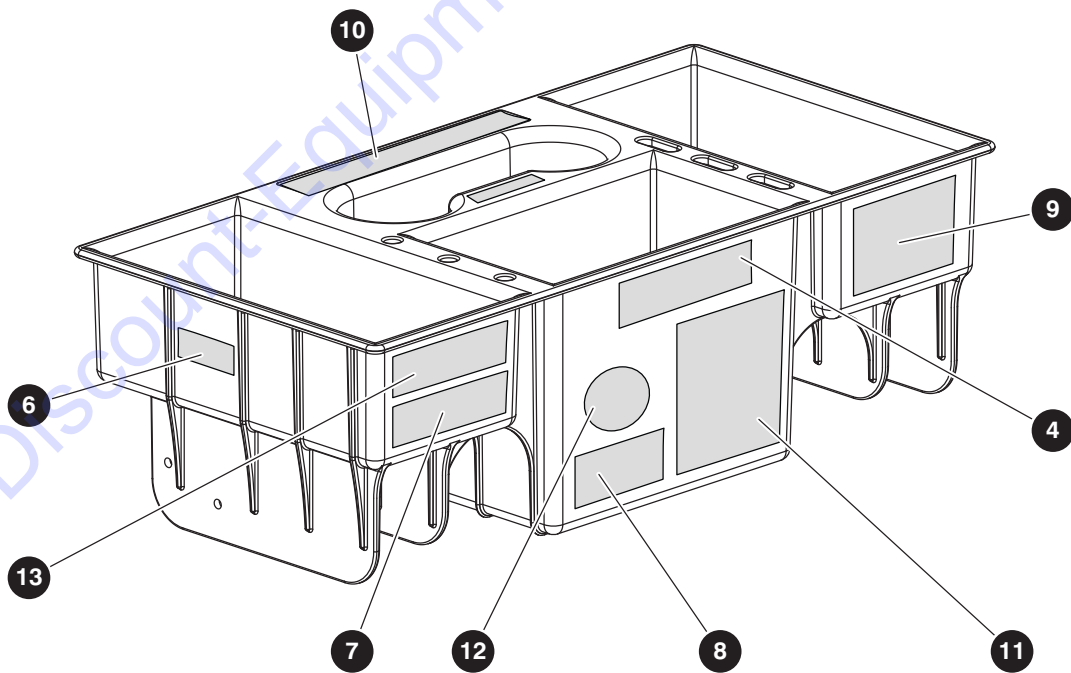
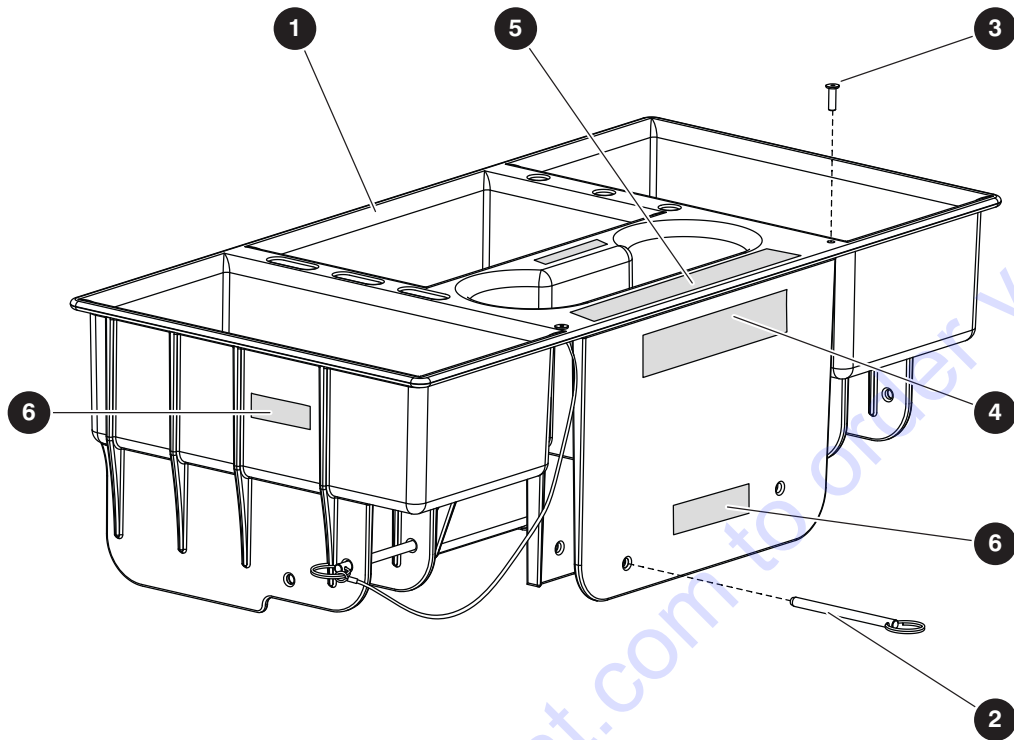

M204334AB

238271AAA

SJ45 AJ+

## 9.7 Tool Caddy

Index No.	Skyjack Part No.	Qty.	Description
-	211271	1	TOOL CADDY KIT
-	204334	1	• TOOL CADDY ASSEMBLY
1	198945	1	• • TOOL CADDY TRAY, Plastic (Std)
2	198965	2	• • PIN, Quick release 1/4x3.2 LG with Lanyard
3	116161	2	• • RIVET, Pop (0.1875" x 0.565")
4	172293	2	• • LABEL, Skyjack logo, 5" white
5	172294	1	• • LABEL, Skyjack logo, 3" white
6	168421	3	• • LABEL, Lock pin in place
7	172245	1	• • LABEL, Tool caddy weight
8	172246	1	• • LABEL, Tool caddy pin location
9	172247	1	• • LABEL, Tool caddy location
10	172292	1	• • LABEL, Accessoryzers, 8" white
11	172298	1	• • LABEL, Tool caddy models serial numbers
12	172299	1	• • LABEL, Do not block exit/entrance
13	172297	1	• • LABEL, Drive slowly when tool caddy is installed
14	204306	1	• INSTRUCTIONS, Tool caddy installation (not shown)

## 9.8 Half-Height Platform Mesh

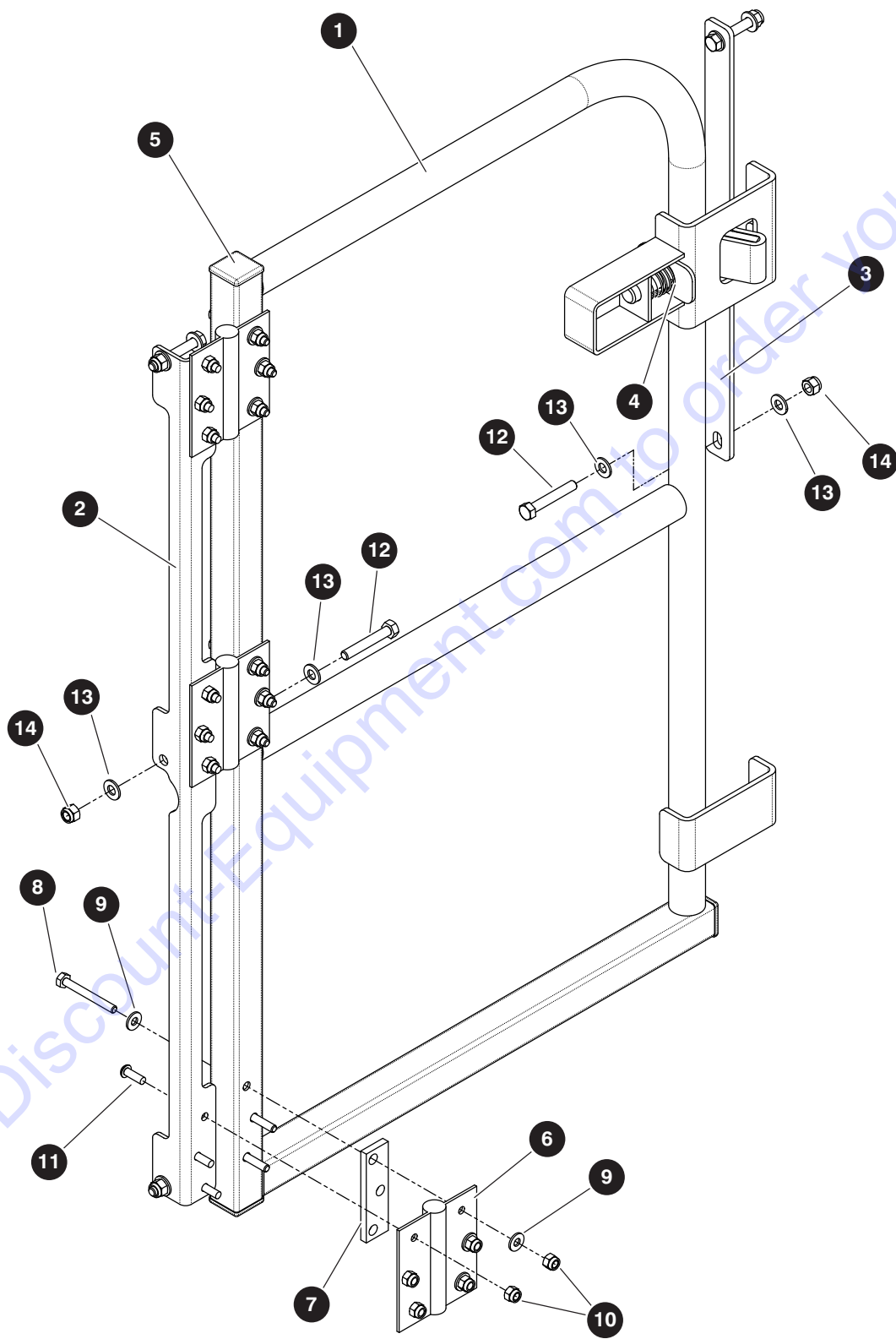

M211359AA

238271AAA

SJ45 AJ+

## 9.8 Half-Height Platform Mesh

Index No.	Skyjack Part No.	Qty.	Description
<b>A</b>	211779	1	• HALF HEIGHT MESH KIT for 6' / 1.83 m Side Entry Platform
<b>B</b>	211780	1	• HALF HEIGHT MESH KIT for 5' / 2.44 m Side Entry Platform
-	211364	1	• MESH ASSEMBLY, Side entry 6' / 2.44 m platform, <b>A</b>
-	211211	1	• MESH ASSEMBLY, Side entry 5' / 2.44 m platform, <b>B</b>
-	211359	1	• • FULL SWING GATE
1	209032	1	• • • GATE, Swing - full
2	211375	1	• • • BRACKET, Mounting - hinge
3	166287	1	• • • PLATE, Locking
4	110824	1	• • • LATCH, Pin - door spring
	105312	1	• • • • BED, Latch
	109377	1	• • • • PIN, Latch (0.625" x 4.187")
	105307	1	• • • • HANDLE, Latch
	103107	1	• • • • SPRING, Compression
	100950		• • • • PIN, Spring (0.125" x 1.00")
5	100702	3	• • • PLUG, Tube (1.25" x 1.25")
6	209527	3	• • • HINGE, Spring
7	164592	3	• • • TAB, Hinge
8	103862	9	• • • BOLT, Hex head (0.25"-20 x 2.25" gr 5)
9	103995	18	• • • WASHER, Flat (0.25")
10	115649	18	• • • NUT, Lock (0.25"-20 gr 5 nylon)
11	139168	9	• • • BOLT, Button head cap screw (0.25"-20 x 0.75")
12	103865	5	• • • BOLT, Hex head (0.312"-18 x 2.00" gr 5)
13	103996	10	• • • WASHER, Flat (0.312")
14	103984	5	• • • NUT, Lock (0.313"-18 gr 5 nylon)
			<b>Parts list continued on the next page.</b>

## 9.8 Half-Height Platform Mesh

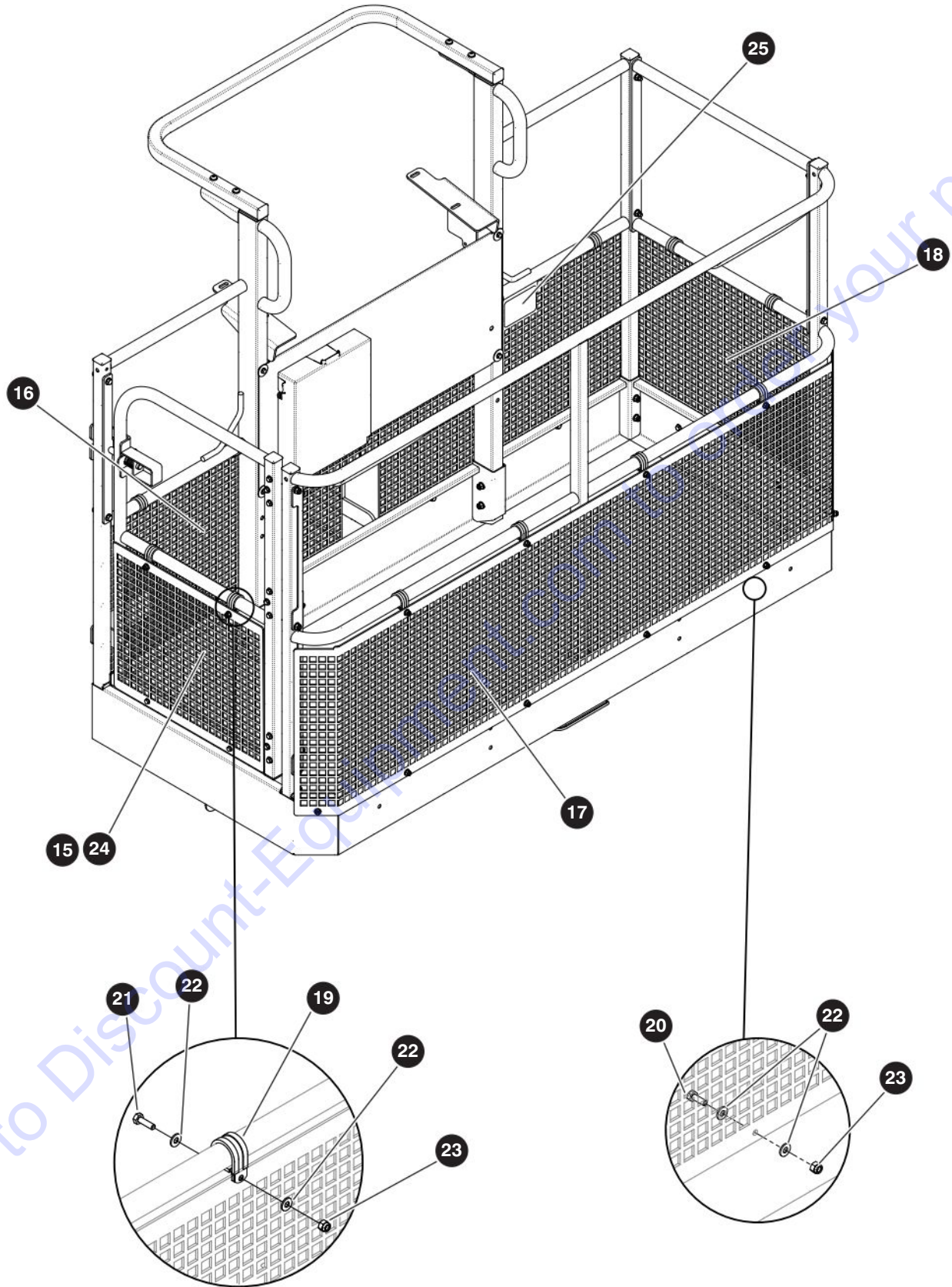

M211779AA

238271AAA

## 9.8 Half-Height Platform Mesh

Index No.	Skyjack Part No.	Qty.	Description
<b>A</b>	211779	1	• HALF HEIGHT MESH KIT for 6' / 1.83 m Side Entry Platform
<b>B</b>	211780	1	• HALF HEIGHT MESH KIT for 5' / 2.44 m Side Entry Platform
<b>Parts list continued from the previous page.</b>			
15	208942	1	• • MESH, Gate
16	211608	1	• • MESH, Front - 30" x 72" / 0.76 m x 1.83 m platform, <b>A</b>
	211610	1	• • MESH, Front - 30" x 60" / 0.76 m x 1.52 m platform, <b>B</b>
17	211606	1	• • MESH, Rear - 30" x 72" / 0.76 m x 1.83 m platform, <b>A</b>
	211609	1	• • MESH, Rear - 30" x 60" / 0.76 m x 1.52 m platform, <b>B</b>
18	211605	1	• • MESH, Side - 30" / 0.76 m platform, <b>A, B</b>
19	209030	12	• • CLAMP, Loop - cushioned (#19), <b>A, B</b>
20	103891	12	• • BOLT, Hex head (0.25"-20 x 0.875" gr 5), <b>A, B</b>
21	103856	12	• • BOLT, Hex head (0.25"-20 x 0.75" gr 5), <b>A, B</b>
22	103995	48	• • WASHER, Flat (0.25"), <b>A, B</b>
23	115649	24	• • NUT, Lock (0.25"-20 gr 5 nylon), <b>A, B</b>
24	103632	2	• • BOLT, Self-tapping hex head (0.25"-14 x 0.75")
25	172519	1	• • LABEL, Mesh weight (25 kg/55 lb)
26	211727	1	• INSTRUCTION, Half height platform mesh installation (not shown)

## 9.9 External Railing

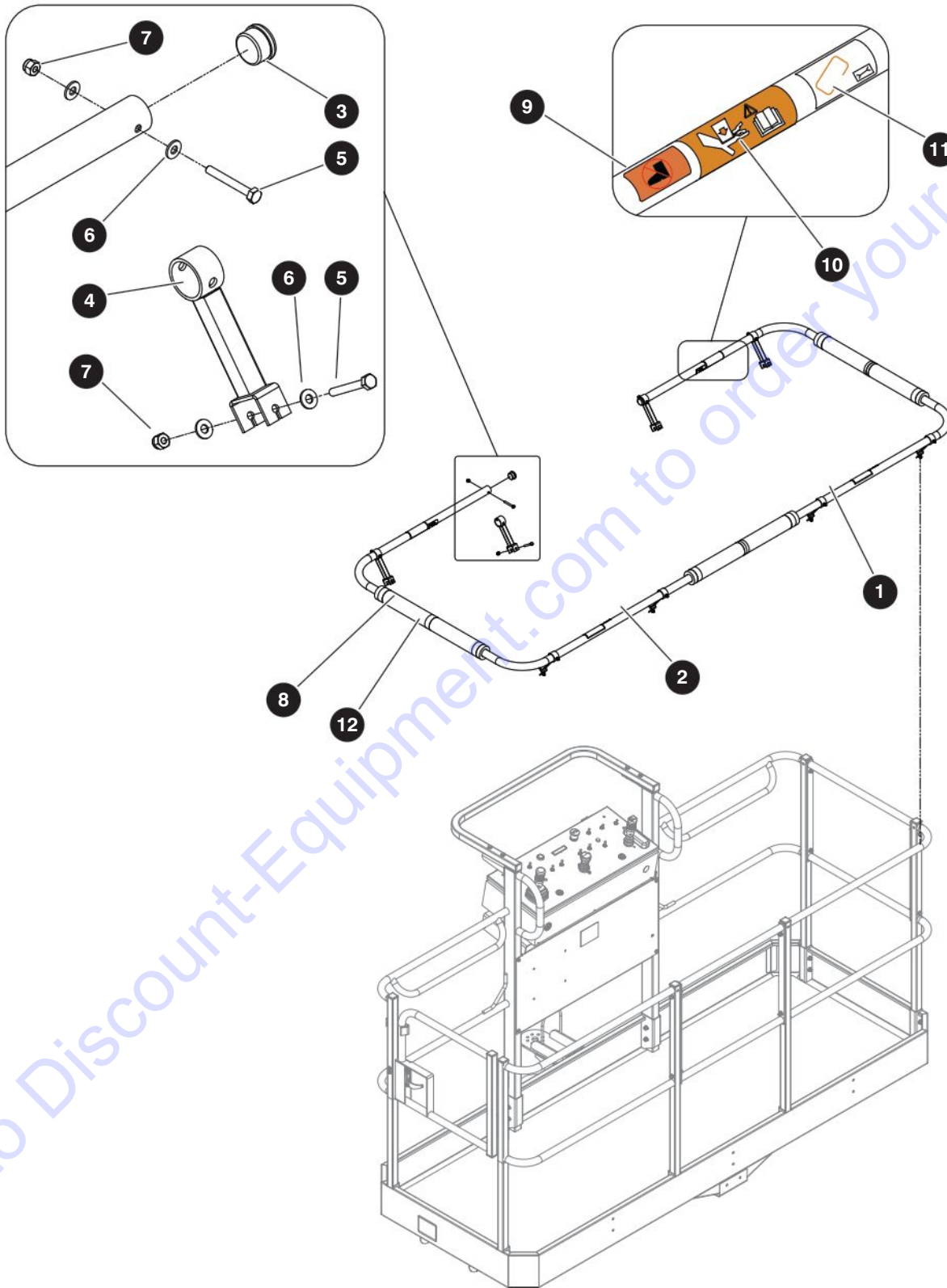

M162055AD\_1

238271AAA

SJ45 AJ+



# PARTS FINDER

**Search Website  
by Part Number**



**Search Manual  
Library For Parts  
Manual & Lookup Part  
Numbers – Purchase  
or Request Quote**

**Search Manuals**

Enter your information to help us find the right parts manual for your equipment.

\* Brand:

\* Model:

\* Serial:

\* Part Number:

SEARCH

**Can't Find Part or  
Manual? Request Help  
by Manufacturer,  
Model & Description**

**Parts Order Form**

Please fill in the following information to help us find the right part for your equipment.

Manufacturer:	<input type="text"/>
Model:	<input type="text"/>
Description:	<input type="text"/>
Part Number:	<input type="text"/>
Quantity:	<input type="text"/>
Notes:	<input type="text"/>

Submit

Discount-Equipment.com is your online resource for quality parts & equipment.

Florida: **561-964-4949** Outside Florida TOLL FREE: **877-690-3101**

**Need parts?**

Click on this link: <http://www.discount-equipment.com/category/5443-parts/> and choose one of the options to help get the right parts and equipment you are looking for. Please have the machine model and serial number available in order to help us get you the correct parts. If you don't find the part on the website or on one of the online manuals, please fill out the request form and one of our experienced staff members will get back to you with a quote for the right part that your machine needs.

We sell worldwide for the brands: Genie, Terex, JLG, MultiQuip, Mikasa, Essick, Whiteman, Mayco, Toro Stone, Diamond Products, Generac Magnum, Airman, Haulotte, Barreto, Power Blanket, Nifty Lift, Atlas Copco, Chicago Pneumatic, Allmand, Miller Curber, Skyjack, Lull, Skytrak, Tsurumi, Husquvarna Target, Stow, Wacker, Sakai, Mi-T-M, Sullair, Basic, Dynapac, MBW, Weber, Bartell, Bennar Newman, Haulotte, Ditch Runner, Menegotti, Morrison, Contec, Buddy, Crown, Edco, Wyco, Bomag, Laymor, EZ Trench, Bil-Jax, F.S. Curtis, Gehl Pavers, Heli, Honda, ICS/PowerGrit, IHI, Partner, Imer, Clipper, MMD, Koshin, Rice, CH&E, General Equipment, Amida, Coleman, NAC, Gradall, Square Shooter, Kent, Stanley, Tamco, Toku, Hatz, Kohler, Robin, Wisconsin, Northrock, Oztec, Toker TK, Rol-Air, APT, Wylie, Ingersoll Rand / Doosan, Innovatech, Con X, Ammann, Mecalac, Makinex, Smith Surface Prep, Small Line, Wanco, Yanmar

## 9.9 External Railing

Index No.	Skyjack Part No.	Qty.	Description
-	152575	1	EXTERNAL RAILING FIELD KIT - <i>for 6' platforms only</i>
-	152574	1	• EXTERNAL RAILING ASSEMBLY
1	152573	1	• • TUBE, External railing (right)
2	152572	1	• • TUBE, External railing (left)
3	144048	2	• • PLUG, Round end
4	144747	8	• • WELDMENT, External railing stand-off
5	103861	16	• • BOLT, Hex head (0.25"-20 x 2" Grade 5)
6	103995	32	• • WASHER, Flat (0.25")
7	115649	16	• • NUT, Hex head nylon lock (0.25"-20 Grade 5)
8	104183	6'	• • PAD, Entry railing
9	115543	6	• • LABEL, Warning no step
10	137988	6	• • LABEL, Hazard crush/pinch point
11	171237	6	• • LABEL, External railing weight
12	119803	1	• • LABEL, Caution tape (108' roll)
13	162030	1	• INSTRUCTION, External railing installation (not shown)

## 9.10 Elevate Telematics

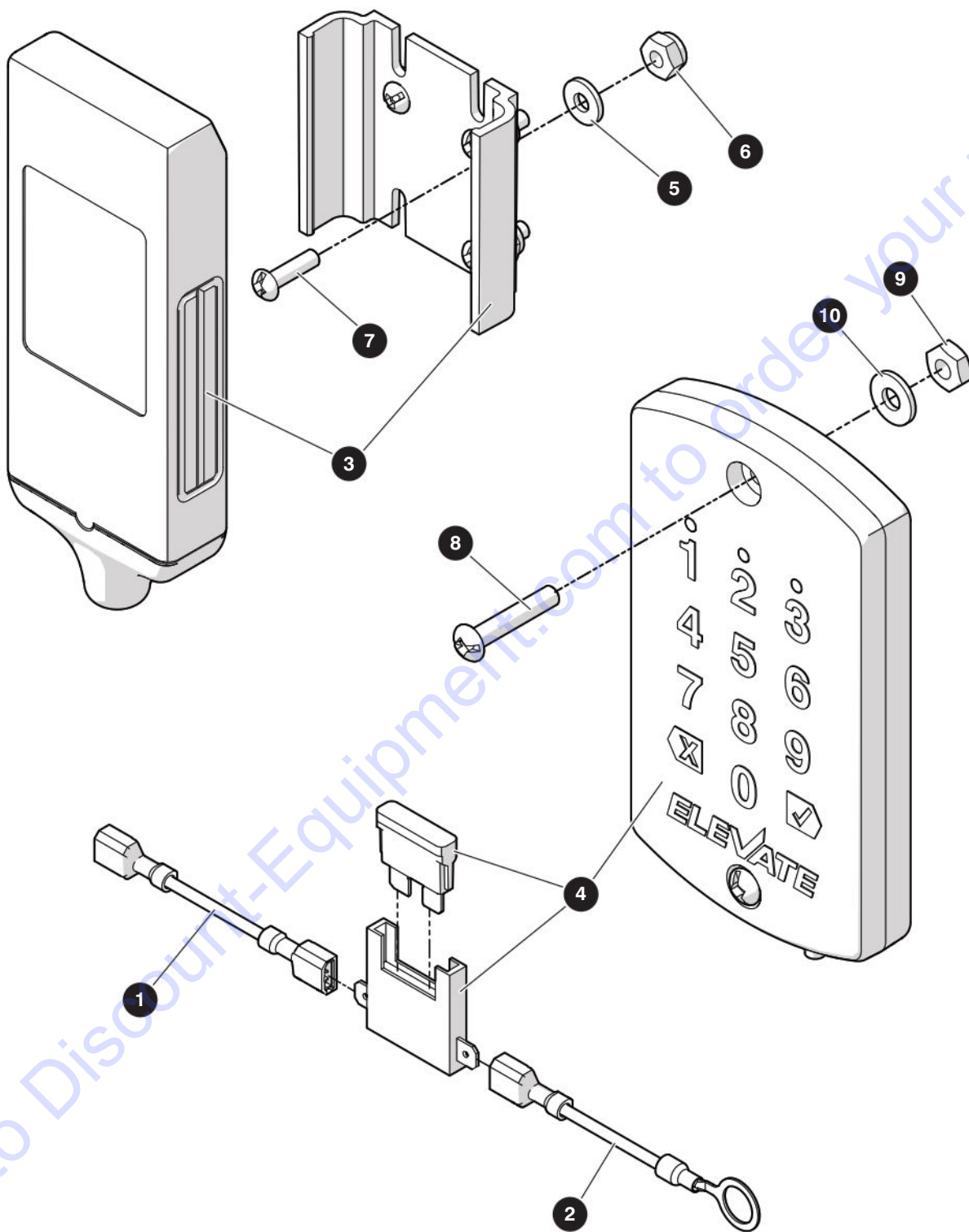

M236118A

238271AAA

SJ45 AJ+

## 9.10 Elevate Telematics

Index No.	Skyjack Part No.	Qty.	Description
			 <b>NOTE</b> A subscription is required to use the Elevate Telematics option. Refer to "Elevate Telematics Subscription" on page 204.
<b>A</b>	236118	1	ELEVATE TELEMATICS WITH KEYPAD INSTALLATION KIT
<b>B</b>	236169	1	ELEVATE TELEMATICS WITHOUT KEYPAD INSTALLATION KIT
-	218453	1	• ELEVATE TELEMATICS INSTALLATION KIT, <b>A</b>
	218454	1	• ELEVATE TELEMATICS INSTALLATION KIT, <b>B</b>
-	236134	1	• • ELEVATE TELEMATICS ASSEMBLY, <b>A</b>
	236135	1	• • ELEVATE TELEMATICS ASSEMBLY, <b>B</b>
1	221149	1	• • • WIRE ASSEMBLY, B+
2	220577	1	• • • WIRE ASSEMBLY, B+
3	213098	1	• • • TELEMATICS, Elevate GPS ME501-4
4	213099	1	• • • TELEMATICS, Elevate keypad, <b>A</b>
5	191833	4	• • • WASHER, Flat (#6)
6	196306	4	• • • NUT, Lock (6-32 gr 5 nylon)
7	114678	4	• • • SCREW, Round head machine (6-32 x 1/2")
8	126499	2	• • • SCREW, Round head machine (8-32 x 7/8"), <b>A</b>
9	103986	2	• • • NUT, Hex (8-32), <b>A</b>
10	103991	2	• • • WASHER, Flat (#8), <b>A</b>
11	102892	20	• TIE, Cable (5-3/8") (not shown)
12	221111	1	• INSTRUCTION, Operating - Elevate telematics (not shown), <b>A</b>
13	236117	1	• INSTRUCTIONS, Elevate telematics installation (not shown)

## 9.11 Elevate Telematics Subscription

Index No.	Skyjack Part No.	Qty.	Description
			 <b>NOTE</b> <i>One of the following subscriptions is required to use the Elevate Telematics option.</i>
1	221153	1	SUBSCRIPTION, Elevate telematics - Monitoring (12 months)
2	221647	1	SUBSCRIPTION, Elevate telematics - Engage (12 months)
3	221348	1	SUBSCRIPTION, Elevate telematics - Engage + Access (12 months)
4	221154	1	SUBSCRIPTION, Elevate telematics - Monitoring (36 months)
5	221650	1	SUBSCRIPTION, Elevate telematics - Engage (36 months)
6	221651	1	SUBSCRIPTION, Elevate telematics - Engage + Access (36 months)
7	221155	1	SUBSCRIPTION, Elevate telematics - Monitoring (60 months)
8	221654	1	SUBSCRIPTION, Elevate telematics - Engage (60 months)
9	221655	1	SUBSCRIPTION, Elevate telematics - Engage + Access (60 months)

# Section 10 – Labels

**10.1** *Label Kit*

**10.2** *Labels - Front and Back*

**10.3** *Labels - Left & Right Sides*

**10.4** *Labels - Platform*

**10.5** *Labels - Controls Compartment*

**10.6** *Labels - Engine Compartment*

## 10.1 Label Kit

The following label kits contain all of the labels required for a complete standard machine, with the exception of:

- Serial number plates
- Engine- and fuel-specific labels (ANSI/CSA only)
- Safety tape
- Powerline clearance (AS only)

Contact Discount-equipment to order those labels individually.

Supply the model number, country, and language when ordering label kits.

Index No.	Skyjack Part No.	Qty.	Description
-	TBD	1	LABEL KIT, SJ45 AJ+ ANSI/CSA
-	TBD	1	LABEL KIT, SJ45 AJ+ CE
-	TBD	1	LABEL KIT, SJ45 AJ+ AS

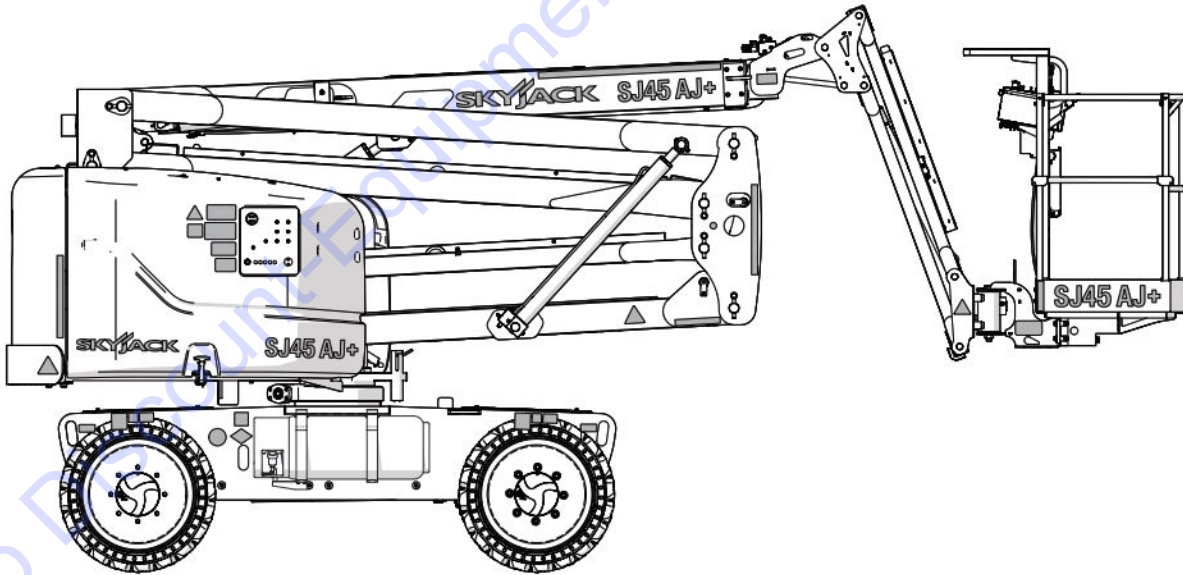

**SKYJACK**™

## 10.2 Labels - Front and Back

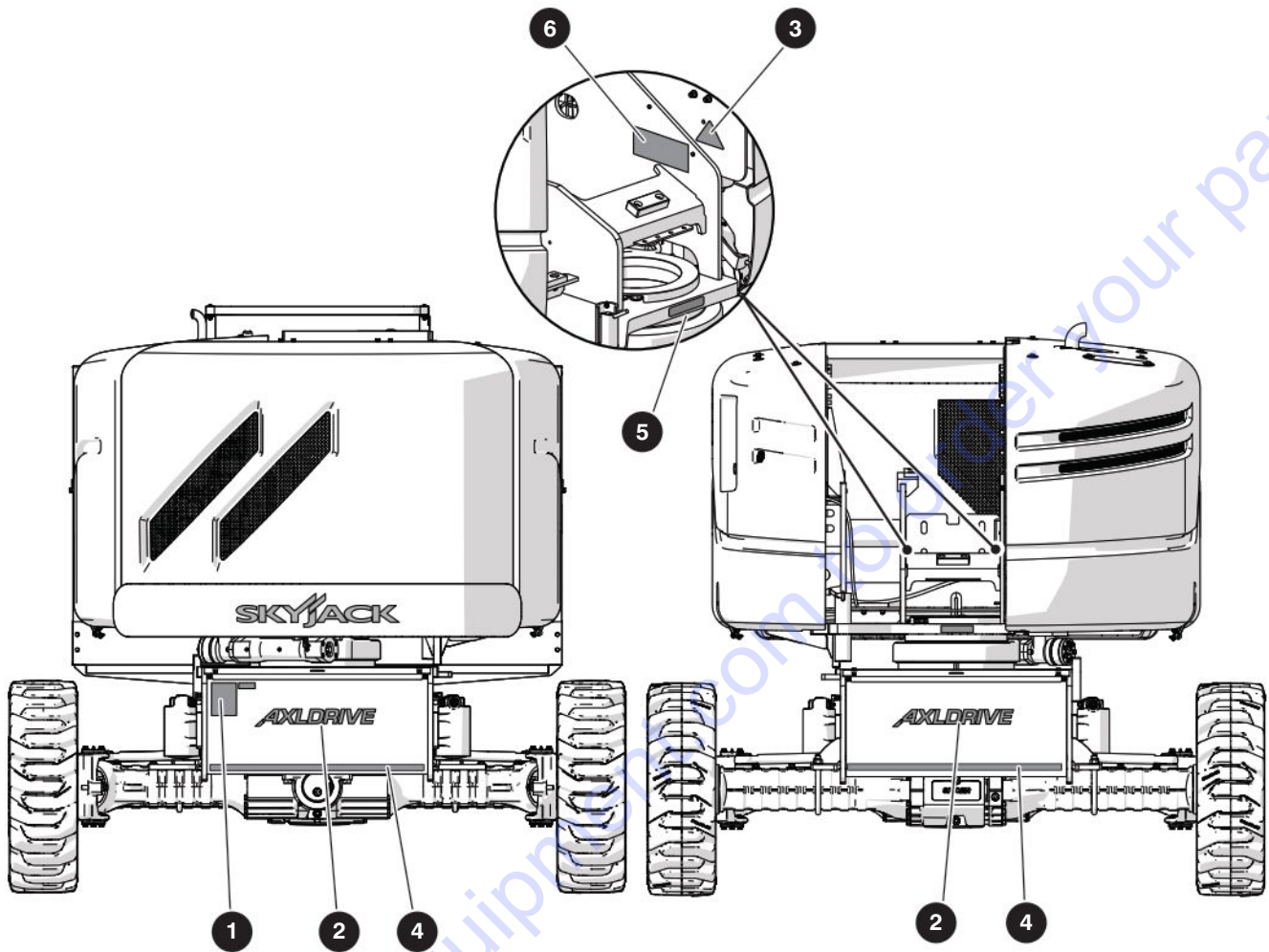

M173532AA\_FB

Index No.	Skyjack Part No.	Qty.	Description
1	(Ref.)	1	LABEL, Serial plate <i>(please consult Discount-equipment)</i>
2	173302	2	LABEL, Axle drive
3	223640	2	LABEL, Body crush
4	119803	60"	TAPE, Caution - 1"
5	138211	1	LABEL, Connect AC supply
6	172680	2	LABEL, Maintenance stand



# 10.3 Labels - Left & Right Sides

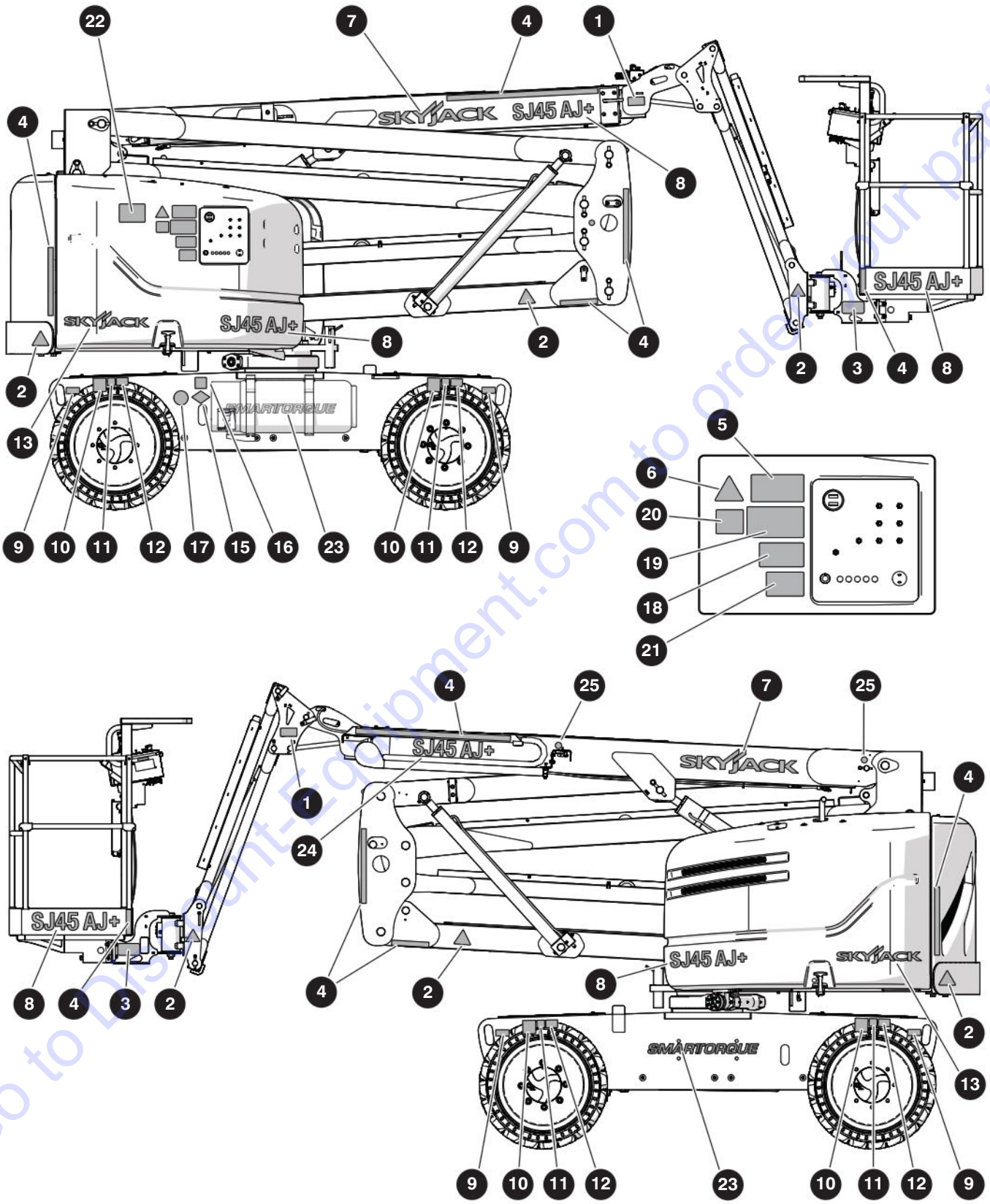

M173506AB\_M173504AB\_CS

238271AAA

SJ45 AJ+

## 10.3 Labels - Left & Right Sides

Index No.	Skyjack Part No.	Qty.	Description
1	137988	2	LABEL, Crush/Pinch point
2	223640	6	LABEL, Body crush
3	147111	2	LABEL, Transportation tie down points TAPE,
4	119803	A/R	Caution - 1"
5	172656	1	LABEL, Annual inspection
6	172695	1	LABEL, Warning annual inspection
7	158555	2	LABEL, Skyjack logo (29")
8	173733	5	LABEL, SJ45 AJ+ (19")
9	124767	9	LABEL, Tie down/lift lugs
10	124631	9	LABEL, Wheel info
11	173858	9	LABEL, Wheel load 2725 kg/6000 lb
12	173202	9	LABEL, Tip over hazard
13	158554	2	LABEL, Skyjack logo (20")
15	120390	1	LABEL, Propane - <b>Kubota WG972</b>
16	103023	1	LABEL, LPG fuel - <b>Kubota WG972</b>
17	138146	1	LABEL, No smoking - <b>Kubota WG972</b>
18	(Ref.)	1	LABEL, QR code ( <b>consult Discount-equipment</b> )
19	173193	1	LABEL, Emergency lowering at base controls
20	172939	1	LABEL, Emergency lowering identification
21	173002	1	LABEL, Elevate telematics - <b>option</b>
22	161631	1	LABEL, Power line clearance - <b>AS</b>
23	238860	2	LABEL, Smarttorque - <b>ANSI/CSA &amp; AS</b>
	238861	2	LABEL, Smarttorque stage V - <b>CE</b>
24	237734	1	LABEL, SJ45 AJ+ (26")
25	156613	2	LABEL, Do not alter

# 10.4 Labels - Platform

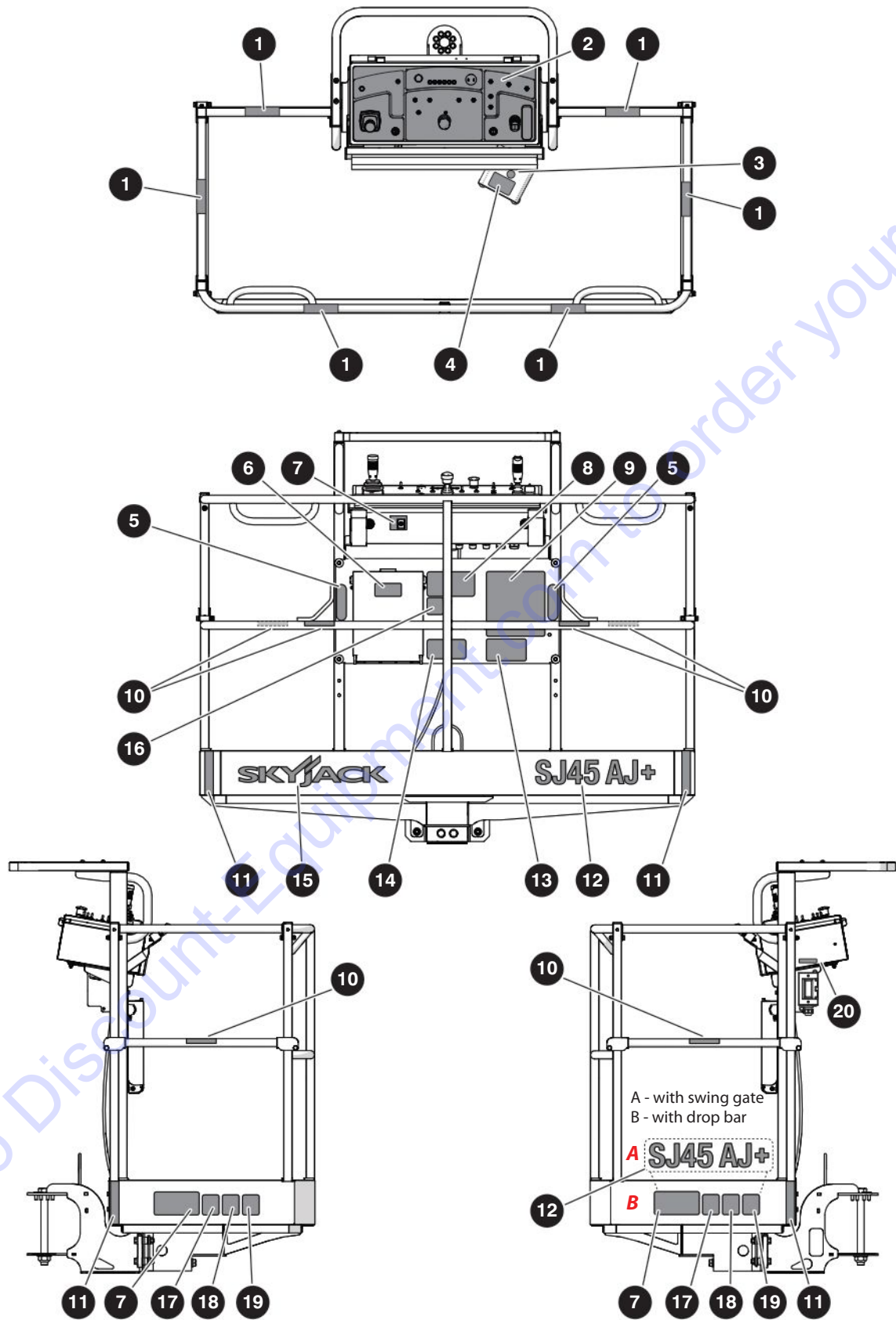

## 10.4 Labels - Platform

Index No.	Skyjack Part No.	Qty.	Description
1	137988	6	LABEL, Crush/Pinch point
2	218299	1	LABEL, Platform Control box
3	156613	1	LABEL, Do not alter
4	143638	1	LABEL, Footswitch enable (on/off)
5	172639	2	LABEL, Harness anchorage
6	123628	1	LABEL, Manual box
7	231398	1	LABEL, Glazier/pipe rack override switch
8	173608	2	LABEL, Platform capacity (300 kg kg/600 lb), <b>A</b>
	173608	3	LABEL, Platform capacity (300 kg kg/600 lb), <b>B</b>
9	173192	1	LABEL, Danger/warning booms
10	115543	6	LABEL, Warning no step
11	119803	24"	LABEL, Caution tape
12	237733	1	LABEL, SJ45AJ (12"), <b>A</b>
	237733	2	LABEL, SJ45AJ (12"), <b>B</b>
13	147043	1	LABEL, AWPT "Click It!"
14	173081	1	LABEL, California proposition 65
15	158554	1	LABEL, Skyjack logo
16	173202	1	LABEL, Tip over hazard
17	159513	1	LABEL, Daily inspection, <b>A</b>
	159513	2	LABEL, Daily inspection, <b>B</b>
18	172693	1	LABEL, Non-insulated, <b>A</b>
	172693	2	LABEL, Non-insulated, <b>B</b>
19	124362	1	LABEL, Warning do not wear jewelry, <b>A</b>
	124362	2	LABEL, Warning do not wear jewelry, <b>B</b>
20	138211	1	LABEL, Connect AC supply

## 10.5 Labels - Controls Compartment

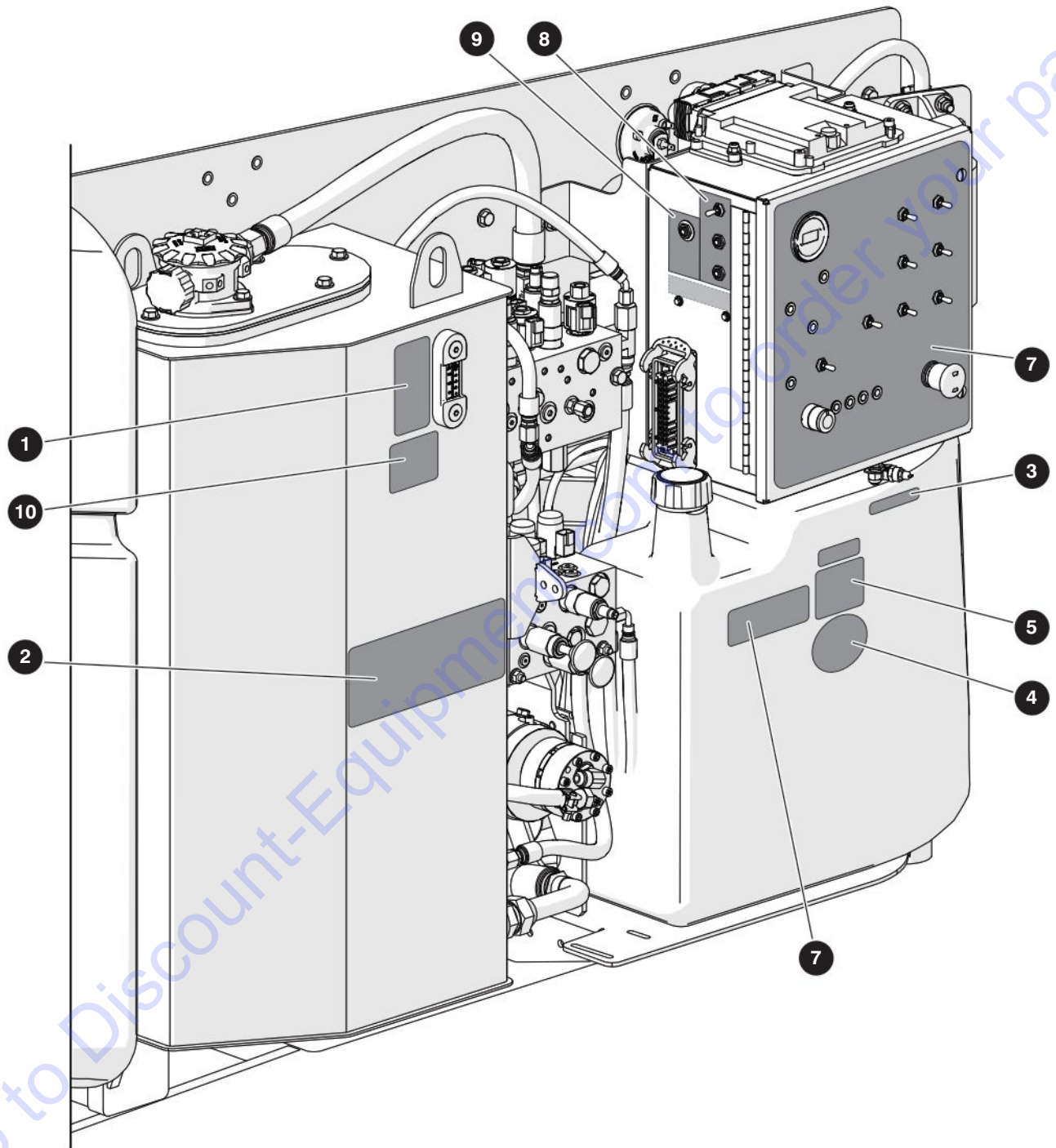

## 10.5 Labels - Controls Compartment

Index No.	Skyjack Part No.	Qty.	Description
1	146016	1	LABEL, Hydraulic oil level (min/max)
2	223638	1	LABEL, Winch/tow procedure
3	172512	1	LABEL, Grease point, Mobilgrease 462 Moly
4	138146	1	LABEL, No smoking
5	162852	1	LABEL, Ultra low sulfur diesel fuel only - <b>Kubota D1305</b>
	132400	1	LABEL, Unleaded gasoline only - <b>Kubota WG972</b>
6	168457	1	LABEL, Open fuel cap slowly - <b>Kubota WG972</b>
7	218265	1	LABEL, Base control box
8	218362	1	LABEL, Side - CB1 & CB2
9	218636	1	LABEL, Side - CB3 & CB4
10	102961	1	LABEL, ATF Dexron - <b>Standard and cold weather options</b>
	144633	1	LABEL, Arctic hydraulic oil - <b>Arctic weather option</b>

## 10.6 Labels - Engine Compartment

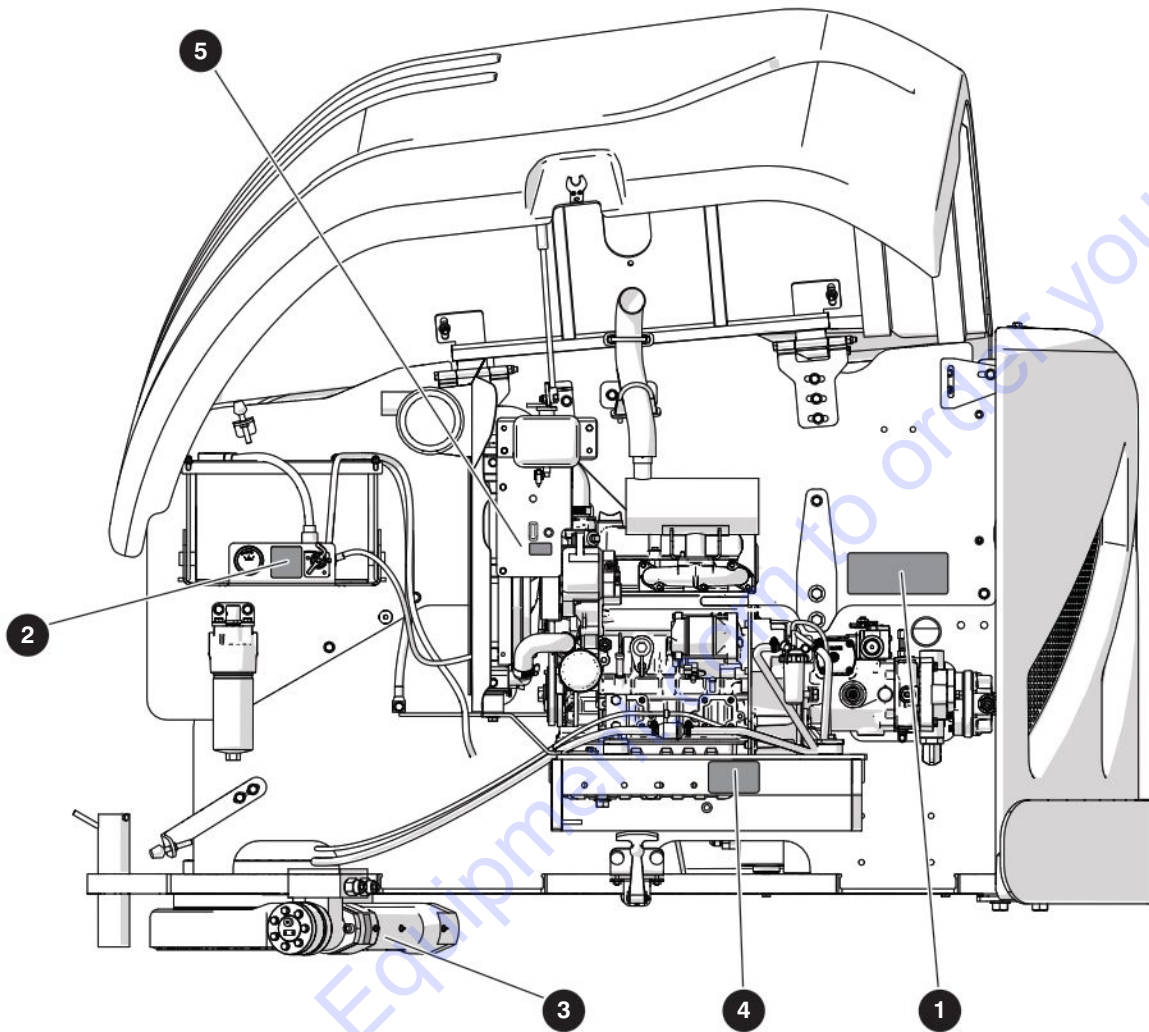

M173506AA\_EC

Index No.	Skyjack Part No.	Qty.	Description
1	223638	1	LABEL, Winch/tow procedure
2	119674	1	LABEL, Battery disconnect switch
3	172512	1	LABEL, Grease point, Mobilgrease 462 Moly
4	(ref.)	1	LABEL, QR code <b>(consult Discount-equipment)</b>
5	169923	1	LABEL, Positive air shut-off - <b>option</b>

# PARTS FINDER

**Search Website  
by Part Number**



**Search Manual  
Library For Parts  
Manual & Lookup Part  
Numbers – Purchase  
or Request Quote**

**Search Manuals**

Enter your information to help us find the right parts manual for your equipment.

\* Brand:

\* Model:

\* Serial:

\* Part Number:

SEARCH

**Can't Find Part or  
Manual? Request Help  
by Manufacturer,  
Model & Description**

**Parts Order Form**

Please fill in the following information to help us find the right part for your equipment.

Manufacturer:	<input type="text"/>
Model:	<input type="text"/>
Description:	<input type="text"/>
Part Number:	<input type="text"/>
Quantity:	<input type="text"/>
Notes:	<input type="text"/>

Submit

Discount-Equipment.com is your online resource for quality parts & equipment.

Florida: **561-964-4949** Outside Florida TOLL FREE: **877-690-3101**

**Need parts?**

Click on this link: <http://www.discount-equipment.com/category/5443-parts/> and choose one of the options to help get the right parts and equipment you are looking for. Please have the machine model and serial number available in order to help us get you the correct parts. If you don't find the part on the website or on one of the online manuals, please fill out the request form and one of our experienced staff members will get back to you with a quote for the right part that your machine needs.

We sell worldwide for the brands: Genie, Terex, JLG, MultiQuip, Mikasa, Essick, Whiteman, Mayco, Toro Stone, Diamond Products, Generac Magnum, Airman, Haulotte, Barreto, Power Blanket, Nifty Lift, Atlas Copco, Chicago Pneumatic, Allmand, Miller Curber, Skyjack, Lull, Skytrak, Tsurumi, Husquvarna Target, Stow, Wacker, Sakai, Mi-T-M, Sullair, Basic, Dynapac, MBW, Weber, Bartell, Bennar Newman, Haulotte, Ditch Runner, Menegotti, Morrison, Contec, Buddy, Crown, Edco, Wyco, Bomag, Laymor, EZ Trench, Bil-Jax, F.S. Curtis, Gehl Pavers, Heli, Honda, ICS/PowerGrit, IHI, Partner, Imer, Clipper, MMD, Koshin, Rice, CH&E, General Equipment, Amida, Coleman, NAC, Gradall, Square Shooter, Kent, Stanley, Tamco, Toku, Hatz, Kohler, Robin, Wisconsin, Northrock, Oztec, Toker TK, Rol-Air, APT, Wylie, Ingersoll Rand / Doosan, Innovatech, Con X, Ammann, Mecalac, Makinex, Smith Surface Prep, Small Line, Wanco, Yanmar