

SKYJACK

PARTS MANUAL

SJ30 AJE, SJ30 ARJE

ARTICULATING BOOM

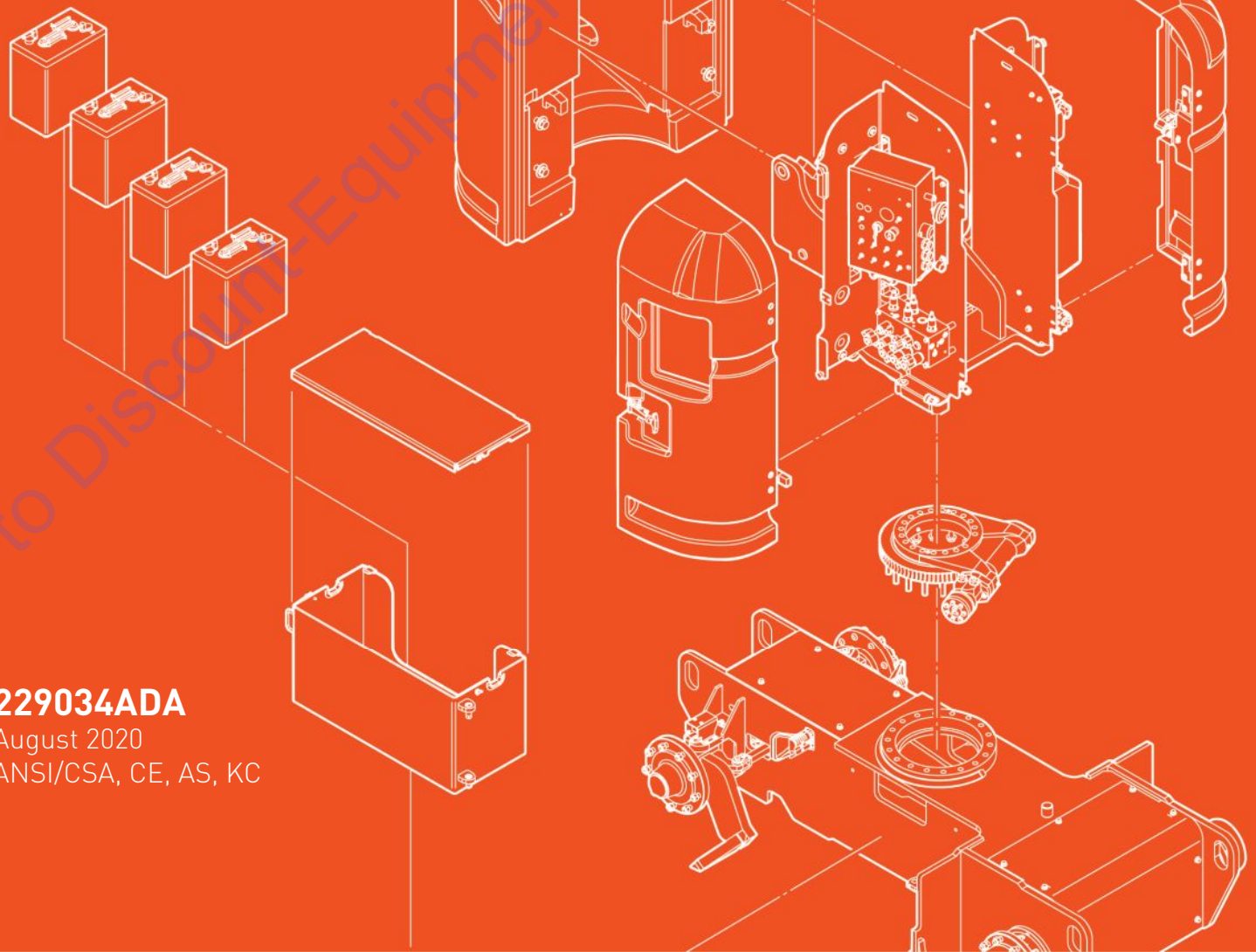

229034ADA

August 2020

ANSI/CSA, CE, AS, KC

PARTS FINDER

**Search Website
by Part Number**



**Search Manual
Library For Parts
Manual & Lookup Part
Numbers – Purchase
or Request Quote**

Search Manuals

Enter your information to help us find the right parts manual for your machine.

* Brand:

* Model:

* Serial:

* Part Number:

SEARCH

**Can't Find Part or
Manual? Request Help
by Manufacturer,
Model & Description**

Parts Order Form

Please fill in the following information to help us find the right part for your machine.

Manufacturer:	<input type="text"/>
Model:	<input type="text"/>
Description:	<input type="text"/>
Part Number:	<input type="text"/>
Quantity:	<input type="text"/>
Notes:	<input type="text"/>

Discount-Equipment.com is your online resource for quality parts & equipment.

Florida: **561-964-4949** Outside Florida TOLL FREE: **877-690-3101**

Need parts?

Click on this link: <http://www.discount-equipment.com/category/5443-parts/> and choose one of the options to help get the right parts and equipment you are looking for. Please have the machine model and serial number available in order to help us get you the correct parts. If you don't find the part on the website or on one of the online manuals, please fill out the request form and one of our experienced staff members will get back to you with a quote for the right part that your machine needs.

We sell worldwide for the brands: Genie, Terex, JLG, MultiQuip, Mikasa, Essick, Whiteman, Mayco, Toro Stone, Diamond Products, Generac Magnum, Airman, Haulotte, Barreto, Power Blanket, Nifty Lift, Atlas Copco, Chicago Pneumatic, Allmand, Miller Curber, Skyjack, Lull, Skytrak, Tsurumi, Husquvarna Target, Stow, Wacker, Sakai, Mi-T-M, Sullair, Basic, Dynapac, MBW, Weber, Bartell, Bennar Newman, Haulotte, Ditch Runner, Menegotti, Morrison, Contec, Buddy, Crown, Edco, Wyco, Bomag, Laymor, EZ Trench, Bil-Jax, F.S. Curtis, Gehl Pavers, Heli, Honda, ICS/PowerGrit, IHI, Partner, Imer, Clipper, MMD, Koshin, Rice, CH&E, General Equipment, Amida, Coleman, NAC, Gradall, Square Shooter, Kent, Stanley, Tamco, Toku, Hatz, Kohler, Robin, Wisconsin, Northrock, Oztec, Toker TK, Rol-Air, APT, Wylie, Ingersoll Rand / Doosan, Innovatech, Con X, Ammann, Mecalac, Makinex, Smith Surface Prep, Small Line, Wanco, Yanmar

This manual is for MEWPs with serial numbers:

SJ30 AJE & SJ30 ARJE: A300 000 001 - A300 999 999

Please refer to the website (www.discount-equipment.com)
for contact information, other serial numbers, the most
recent technical manuals, and USB software.

Go to Discount-Equipment.com to order your parts

Table of Contents

Foreword	7
General.....	7
Parts Ordering Information.....	7
Method of Listing.....	7
Quantities.....	7
How To Order Repair Parts.....	7
Recommended Service Parts.....	8
Section 1 – Platform	11
1.1 Platform Assembly.....	12
1.2 Platform.....	14
1.3 Drop Bar Gate.....	16
1.4 Swing Gate.....	18
1.5 Platform Limit Switches - KC.....	20
1.6 Platform Control Box.....	22
1.7 Drive/Steer Controller.....	28
1.8 Boom/Turret Controller.....	30
1.9 Platform Terminal Strip.....	32
1.10 Footswitch.....	33
1.11 SGE.....	34
1.12 Power Outlet 110 V - ANSI/CSA.....	35
1.13 Power to Platform - Outlet and Plugs - CE.....	36
Section 2 – Boom	39
2.1 Riser Boom.....	40
2.2 Link Arm.....	42
2.3 Lower Riser Arm.....	43
2.4 2nd Riser Arm - Right.....	44
2.5 2nd Riser Arm - Left.....	45
2.6 3rd Riser Arm.....	46
2.7 Upper Riser Arm.....	47
2.8 Lower Knuckle.....	48
2.9 Upper Knuckle.....	50
2.10 Limit Switches.....	52
2.11 Main Boom.....	54
2.12 Fly Boom.....	56
2.13 Cable Track.....	58
2.14 Rotating Jib Manifold.....	60

2.15	Non-Rotating Jib Manifold	61
2.16	Jib Arm Assembly	62
2.17	Rotating Jib	64
2.18	Non-Rotating Jib	66
Section 3 – Cylinders		67
3.1	Riser Cylinder	68
3.2	Main Boom Cylinder	70
3.3	Extension Cylinder	72
3.4	Master Cylinder	74
3.5	Slave Cylinder	76
3.6	Jib Cylinder	78
3.7	Steering Cylinder	80
Section 4 – Turret		83
4.1	Turret	84
4.2	Left Side Subcomponents	86
4.3	Right Side Subcomponents	88
4.4	Lower Control Box	90
4.5	Terminal Block	96
4.6	Direction Sensing Switch	97
4.7	Main Pump	98
4.8	Emergency Pump	100
4.9	Main Manifold	102
4.10	Left Cowling	104
4.11	Right Cowling	106
4.12	Counterweights	108
4.13	Grease Line	110
Section 5 – Electrical Harnesses		111
5.1	Control Cables	112
5.2	Motor Controller Harness "A"	114
5.3	Motor Controller Harness "B"	115
5.4	Main Manifold Harness	116
5.5	Steering Sensor Harness	117
5.6	Charger Harness	118
5.7	Riser Cylinder Lowering Harness	119
5.8	Anti - Overriding Posts Harness - KC	120
5.9	Upper Control Harness - KC	121
5.10	Lower Control Harness - KC	122
Section 6 – Base		123
6.1	Chassis	124
6.2	Steering	126
6.3	Steering Sensor	128

6.4	Swing Drive	130
6.5	Electrical Components	132
6.6	Battery Trays	134
6.7	Batteries.....	136
6.8	Battery Charger	140
6.9	Tires	142
Section 7 – Hose Connections		143
7.1	Standard Hose Numbering System	144
7.2	Hydraulic Hoses - Base.....	146
7.3	Hydraulic Hoses - Turret	148
7.4	Hydraulic Hoses - Boom	150
7.5	Hydraulic Hoses - Jib	152
Section 8 – Optional Equipment		155
8.1	Inverter.....	156
8.2	Inverter Shut-Off Timer	158
8.3	Pipe Rack.....	160
8.4	Flashing Light	162
8.5	Control Box Cover.....	164
8.6	Tool Caddy.....	166
8.7	Additional Anti-Overriding Posts - KC	168
8.8	Seconday Guarding - Electrical (SGE) - KC	170
8.9	Air Line.....	171
8.10	Platform Mesh	172
8.11	Elevate Telematics	176
8.12	Elevate Telematics Subscription.....	178
Section 9 – Labels		181
9.1	Label Kit.....	183
9.2	Labels - Controls Side.....	184
9.3	Labels - Tank Side	186
9.4	Labels - Front, Back & Top	188
9.5	Labels - Platform	190
9.6	Labels - Hoses - KC.....	192

Foreword

General

The information contained in this manual is designed to aid the user in locating and identifying replacement parts. Component parts of various assemblies and subassemblies comprising the work platform are illustrated and accompanied by a descriptive parts list. Exploded drawings are used to show relative location of component parts in disassembly order. If a part cannot be found in this manual, contact Discount-equipment for assistance.

Parts Ordering Information

When ordering replacement parts, the complete part number and description should be used to ensure proper identification and delivery of the desired item. This complete identification should also be used when requesting equipment information.

Method of Listing

Parts are listed in order according to the reference number shown in the illustration, followed by a full description based upon the "NOUN FIRST" method. That is, the noun name of the part is listed first, then the modifying description information which serves to specifically identify the item. For example: PIN, Clevis.

Assemblies at the beginning of a parts list may be identified with a reference letter: A, B, C, etc. These letters are used to identify different configurations of the assembly. Individual parts in these lists have corresponding letters after their description to identify which assembly it is used in. If a part does not have a reference letter, it is used in all of the assemblies.

Bullets (•) are used to show the assembly structure, or parent/child relationship. A part listed at the beginning of the parts list without a bullet before the description is the main assembly, and all of the parts below it with one bullet are the subcomponent parts of that assembly. Two bullets denote a subcomponent of a subcomponent, etc.

Example:

Main Assembly A

- Part 1 (subcomponent of Main Assembly A)
- Part 2 (subcomponent of Main Assembly A)
- • Part 3 (subcomponent of Part 2)

Quantities

The quantities required to complete the assembly are given for each part. If the quantity is (AR), it is understood that the quantity may vary when the machine is equipped with certain options. Order quantity as needed.

How To Order Repair Parts

1. Address all orders to Discount-equipment
2. Specify model and serial number of the work platform (found on the serial number plate).
3. List the quantity needed.
4. List the length needed (if it is a bulk item).
5. List the part number and description as shown in this manual for each item.
6. Show the billing and shipping address and the name of the individual, if possible.
7. Suggest the best routing.

Customer: _____

Dealer: _____

Model Number: _____

Serial Number: _____

Date Purchased: _____

Recommended Service Parts

Description	Year 1 Qty	Year 2 Qty	Year 3 Qty	Skyjack Part No.
Electrical				
SWITCH, Limit - platform (long) KC	0	1	1	207313
SWITCH, Limit - platform (short) KC	0	1	1	207312
SWITCH, Limit - fly boom	0	1	1	192178
SWITCH, Limit - riser	0	1	1	192177
SWITCH, Limit - direction sensing	0	0	1	192758
BATTERY	8	8	8	701048
MOTOR, Wheel - electric with brake	0	0	2	192066
CONTROLLER, ACE0	0	0	1	207406
CONTROLLER, ACE0 Combi	0	0	1	207403
CONVERTER	0	0	1	207405
FUSE, 350A	0	0	1	207408
CONTACTOR	0	0	1	207404
Hydraulic				
SEAL KIT, Riser cylinder	0	0	1	209115
SEAL KIT, Main Boom cylinder	0	0	1	209126
SEAL KIT, Extension cylinder	0	0	1	209205
SEAL KIT, Master cylinder	0	0	1	209192
TOOL, Master cylinder removal	0	0	1	207288
SEAL KIT, Slave cylinder	0	0	1	209193
SEAL KIT, Jib cylinder	0	0	1	209208
SEAL KIT, Steering cylinder	0	0	1	209092
SEAL KIT, Actuator - jib	0	0	1	144709
SEAL KIT, Actuator - platform	0	0	1	209194
SEAL KIT, Swing drive	0	0	1	207355
FILTER, Hydraulic	0	0	1	136405
ELEMENT, Filter - hydraulic	2	2	2	108628
Base				
SEAL KIT, Torque hub	0	0	1	209458
BUSHING, Steering king pin	0	1	1	148847
SEAL, Free-spinning hub	0	1	1	207247
BEARING, Inner	0	0	1	207248
BEARING, Outer	0	0	1	207249
STUD, Wheel	0	9	9	207249
SHIM KIT, Swing drive	0	0	1	207357

Section 1 – Platform

- Platform Control Box** 1.6
- Drive/Steer Controller** 1.7
- Boom/Turret Controller** 1.8
- Platform Terminal Strip** 1.9

- 1.5 Platform Limit Switches - KC**
- 1.11 SGE**
- 1.1 Platform Assembly**
- 1.2 Platform**

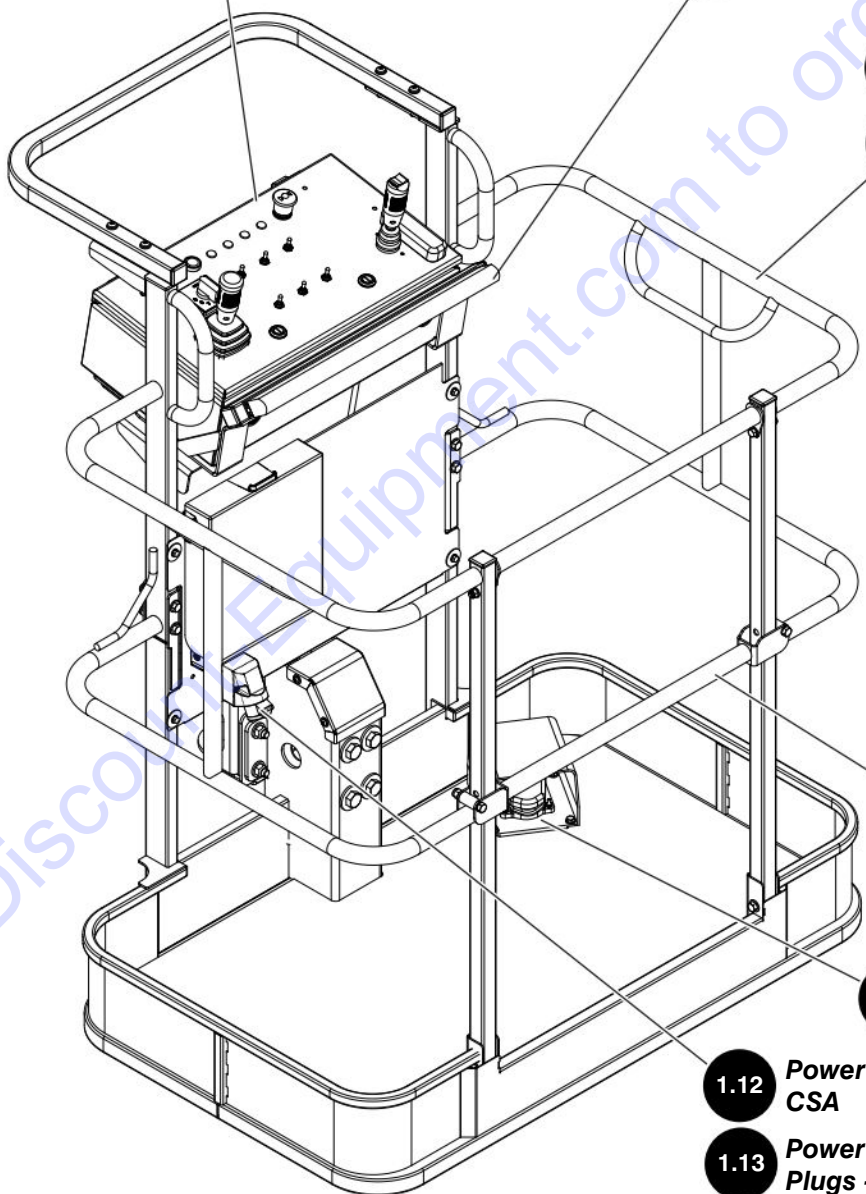

- 1.3 Drop Bar Gate**
- 1.4 Swing Gate**
- 1.10 Footswitch**

- 1.12 Power Outlet 110 V - ANSI/CSA**
- 1.13 Power to Platform - Outlet and Plugs - CE**

1.1 Platform Assembly

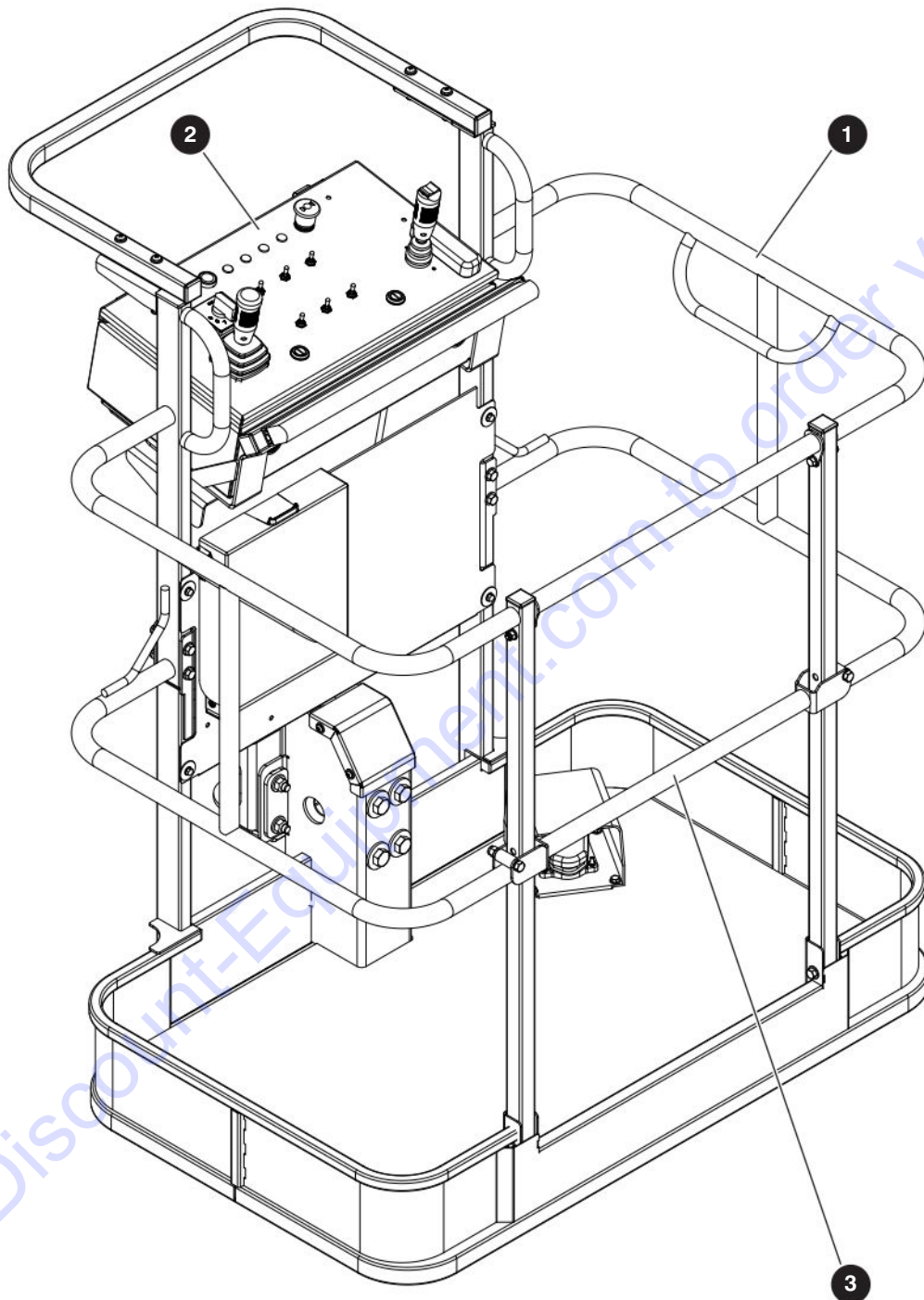

M192561AB

229034ADA

SJ30 AJE, SJ30 ARJE

1.1 Platform Assembly

Index No.	Skyjack Part No.	Qty.	Description
A	192220	1	PLATFORM ASSEMBLY - 46" x 30" with Drop Bar Gate
B	192250	1	PLATFORM ASSEMBLY - 46" x 30" with Swing Gate
1	(Ref.)	1	<ul style="list-style-type: none"> PLATFORM (For components, refer to 1.2 Platform)
2	(Ref.)	1	<ul style="list-style-type: none"> PLATFORM CONTROL BOX (For components, refer to 1.6 Platform Control Box)
3	(Ref.)	1	<ul style="list-style-type: none"> DROP BAR GATE (For components, refer to 1.3 Drop Bar Gate), A
	(Ref.)	1	<ul style="list-style-type: none"> SWING GATE (For components, refer to 1.4 Swing Gate), B

1.2 Platform

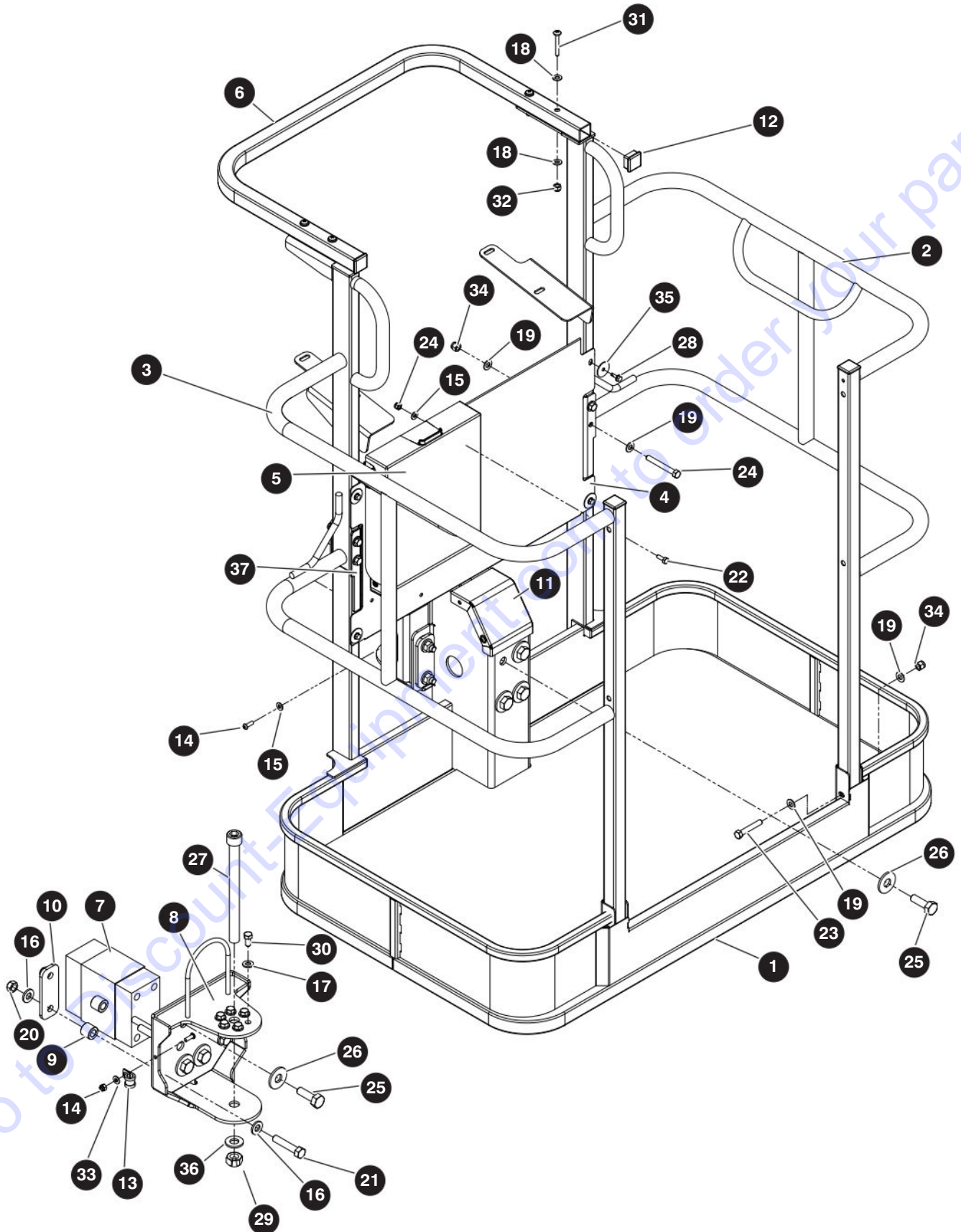

M192561AD

229034ADA

SJ30 AJE, SJ30 ARJE

1.2 Platform

Index No.	Skyjack Part No.	Qty.	Description
-	192561	1	RAILING ASSEMBLY (46" X 30")
1	192562	1	• WELDMENT, Platform base
2	192245	1	• WELDMENT, Railing - right
3	192251	1	• WELDMENT, Railing - left
4	192261	1	• WELDMENT, Platform guard
5	198789	1	• BOX, Manual
6	192244	1	• TUBE, Front railing (1.25" x 0.083")
7	144363	1	• LOAD CELL, MOBA
8	192855	1	• WELDMENT, Rotator mount
9	144574	4	• SPACER, Load cell
10	144365	2	• WASHER, Safety
11	192584	1	• PLATE, Platform cover
12	100702	4	• CAP, Plastic end
13	152402	1	• CLAMP, Tube (0.75")
14	139168	5	• BOLT, Button head cap screw (0.25"-20 x 0.75")
15	103995	9	• WASHER, Flat (0.25" SAE)
16	104379	8	• WASHER, Flat (0.50" SAE hard)
17	125959	6	• WASHER, Flat (0.375" SAE hard)
18	103996	8	• WASHER, Flat (0.312" SAE)
19	103472	16	• WASHER, Flat (0.375" SAE)
20	138791	4	• NUT, Torque lock (0.50"-13 gr C)
21	106447	4	• BOLT, Hex head (0.50"-13 x 2.25" gr 8)
22	103856	4	• BOLT, Hex head (0.25"-20 x 0.75" gr 5)
23	103872	4	• BOLT, Hex head (0.375"-16 x 2.25" gr 5)
24	125958	4	• BOLT, Hex head (0.375"-20 x 3.00" gr 5)
25	207265	8	• BOLT, Hex head patch (M16 x 1.5 x 35 gr 8.8 zp)
26	144329	8	• WASHER, Flat (17 mm ID x 30 mm OD x 3 mm zn hard)
27	192296	1	• SCREW, Socket head cap (0.75"-10 x 9.00")
28	103632	4	• SCREW, Hex head self-tapping (0.25"-14 x 0.75")
29	700575	1	• NUT, Torque lock (0.75"-10 gr c)
30	192209	6	• BOLT, Hex head patch (0.375"-16 x 0.75" gr 8)
31	139008	4	• SCREW, Round head machine (0.313"-18 x 2.00")
32	103984	4	• NUT, Lock (0.313"-18 gr 5 nylon)
33	115649	5	• NUT, Lock (0.25"-20 gr 5 nylon)
34	104606	8	• NUT, Lock (0.375"-16 gr 5 nylon)
35	700598	4	• WASHER, Fender
36	103990	1	• WASHER, Flat (0.75")
37	114377	2	• PLUG, Plastic (0.50")
38	173200	1	• MANUAL, Manual of responsibilities (not shown)
39	221394	1	CORD, Patch - MOBA load cell (not shown)
40	144456	1	TOOL, Hand set - MOBA Teach-in (not shown)

1.3 Drop Bar Gate

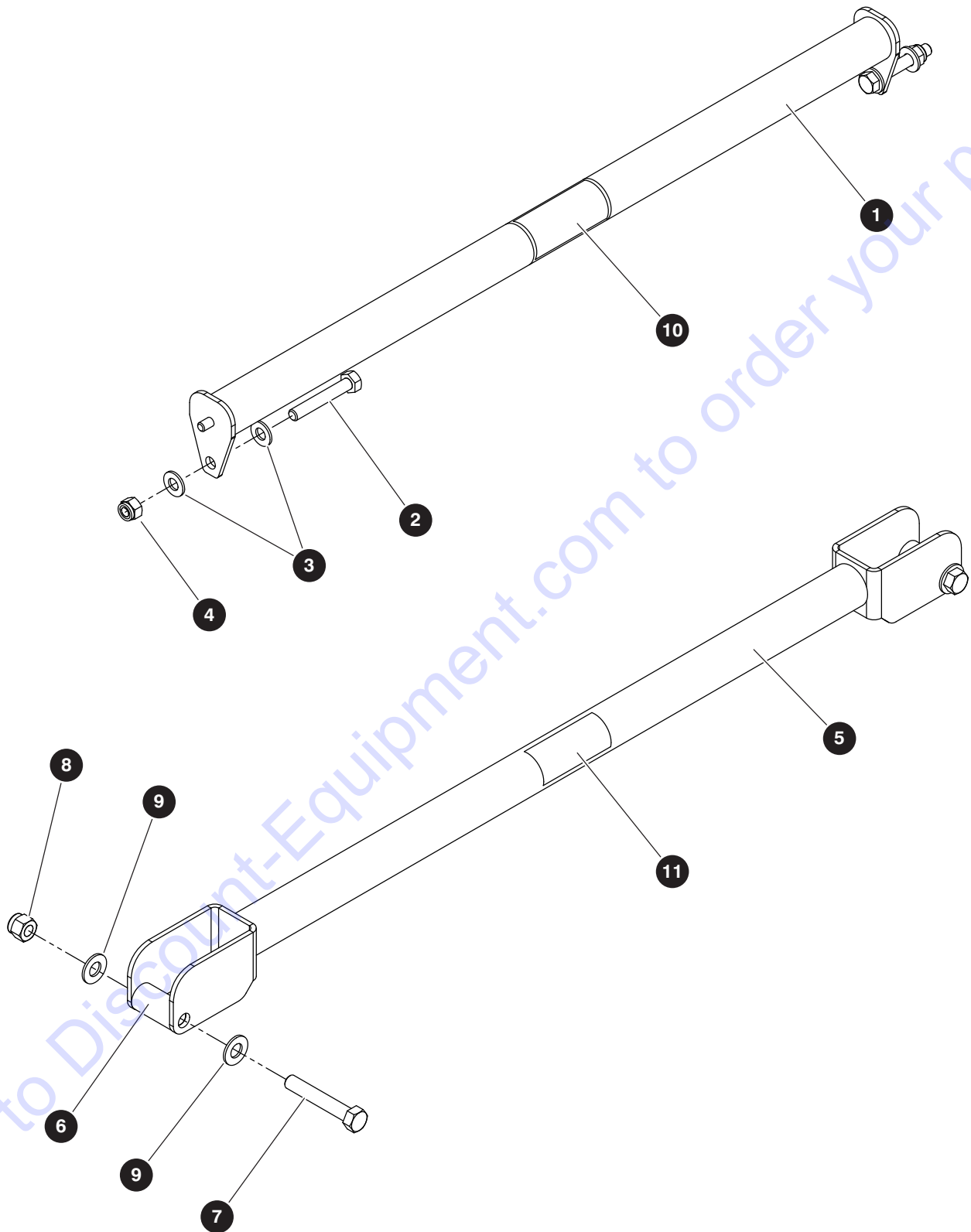

M60880AB

229034ADA

SJ30 AJE, SJ30 ARJE

1.3 Drop Bar Gate

Index No.	Skyjack Part No.	Qty.	Description
-	207391	1	DROP BAR GATE FIELD KIT
-	192280	1	• DROP BAR ASSEMBLY
1	160708	1	• • WELDMENT, Tie bar
2	103865	2	• • BOLT, Hex head (0.312"-18 x 2.00" gr 5)
3	103996	4	• • WASHER, Flat (0.312")
4	103984	2	• • NUT, Hex head nylon lock (0.312"-18 gr 5)
-	162965	1	• • DROP BAR ASSEMBLY
5	162958	1	• • • WELDMENT, Drop bar
6	154386	2	• • • SPACER (0.375" ID x 0.75" OD x 1.375" lg)
7	103872	2	• • • BOLT, Hex head (0.375"-16 x 2.25" gr 5)
8	104606	2	• • • NUT, Hex head nylon lock (0.375"-16 gr 5)
9	103472	4	• • • WASHER, Flat (0.375")
10	137988	1	• LABEL, Crush/pinch hazard
11	115543	1	• LABEL, "No step"
12	194067	1	• INSTRUCTION, Drop bar installation (not shown)

1.4 Swing Gate

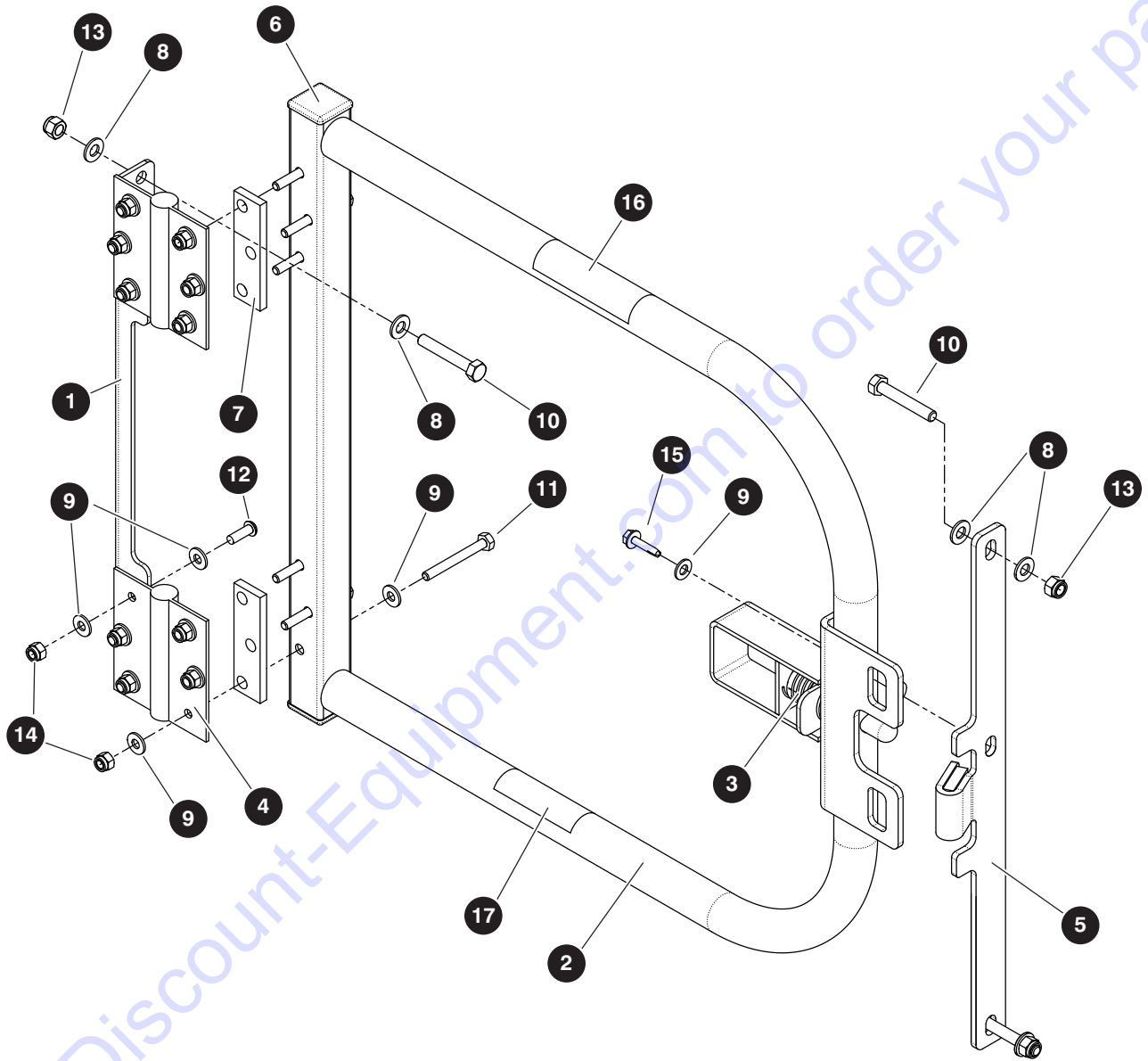

M192290AE

229034ADA

SJ30 AJE, SJ30 ARJE

1.4 Swing Gate

Index No.	Skyjack Part No.	Qty.	Description
-	207374	1	SWING GATE FIELD KIT
-	192290	1	• SWING GATE
1	207216	1	• • BRACKET, Hinge mount
2	164593	1	• • GATE, Swing
3	110824	1	• • LATCH, Spring
4	117277	2	• • HINGE, Spring
5	166288	1	• • PLATE, Locking
6	100702	2	• • PLUG, Tube (1.25" x 1.25")
7	164592	2	• • TAB, Hinge
8	103996	8	• • WASHER, Flat (0.312" SAE)
9	103995	25	• • WASHER, Flat (0.25" SAE)
10	103865	4	• • BOLT, Hex head (0.312"-18 x 2.00" gr 5)
11	103862	6	• • BOLT, Hex head (0.25"-20 x 2.25" gr 5)
12	139168	6	• • BOLT, Button head cap screw (0.25"-20 x 0.75" gr 5)
13	103984	4	• • NUT, Lock (0.313"-18 gr 5 nylon)
14	115649	12	• • NUT, Lock (0.25"-20 gr 5 nylon)
15	112329	1	• • BOLT, Self-tapping (0.25"-14 x 1.00")
16	137988	1	• LABEL, Crush/pinch hazard
17	115543	1	• LABEL, "No step"
18	194065	1	• INSTRUCTION, Swing gate installation (not shown)

1.5 Platform Limit Switches - KC

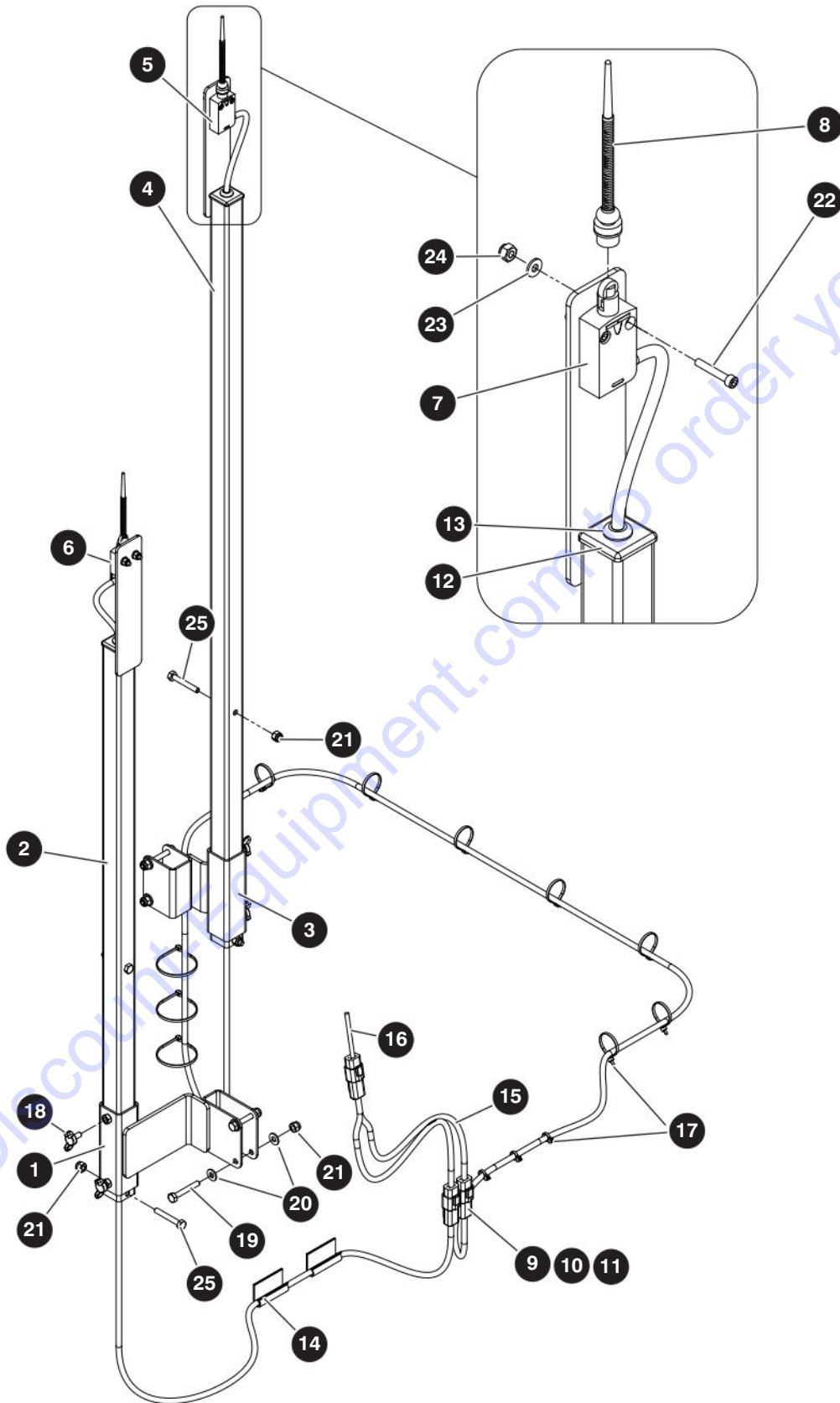

M207211AA

229034ADA

SJ30 AJE, SJ30 ARJE

1.5 Platform Limit Switches - KC

Index No.	Skyjack Part No.	Qty.	Description
-	207211	1	ANTI-OVERRISING POSTS - KC
1	207212	1	• CLAMP, Limit Switch
2	207863	1	• TUBE, Front
3	207858	1	• BRACKET
4	207308	1	• TUBE, Rear
5	207313	1	• LIMIT SWITCH ASSEMBLY - Long
6	207312	1	• LIMIT SWITCH ASSEMBLY - Short
7	119348	1	• • SWITCH, Limit
8	207485	1	• • HEAD, Spring - limit switch
9	117578	1	• • CONNECTOR, Receptacle (4-pin)
10	117580	1	• • CONNECTOR, Receptacle (4-pin wedge)
11	117590	4	• • CONNECTOR, Pin contact (16-18)
12	208898	1	• • PLUG, Tube
13	208897	1	• • GROMMET, Rubber (0.66" OD x 0.28" ID x 0.42")
14	108791	2	• CLIP, Cord - adhesive
15	207314	1	• HARNESS, Limit switch - KC (For components, refer to 5.8 Anti - Overriding Posts Harness - KC)
16	208906	1	• HARNESS, Upper controls - KC (For components, refer to 5.9 Upper Control Harness - KC)
17	102892	14	• TIEWRAP, Cable (5.375")
18	192361	4	• SCREW, Wing (0.25"-20 x 0.50" gr 5)
19	103861	2	• BOLT, Hex head (0.25"-20 x 2.00" gr 5)
20	103995	8	• WASHER, Flat (0.25")
21	115649	8	• NUT, Lock (0.25"-20 gr 5 nylon)
22	207325	4	• SCREW, Socket head cap (8-32 x 1.00")
23	103991	4	• WASHER, Flat (#8)
24	138765	4	• NUT, Lock (8-32 gr 5 nylon)
25	103860	6	• BOLT, Hex head (0.25"-20 x 1.75" gr 5)
26	209079	1	• HARNESS, Lower controls - KC (not shown) (For components, refer to 5.10 Lower Control Harness - KC)

1.6 Platform Control Box

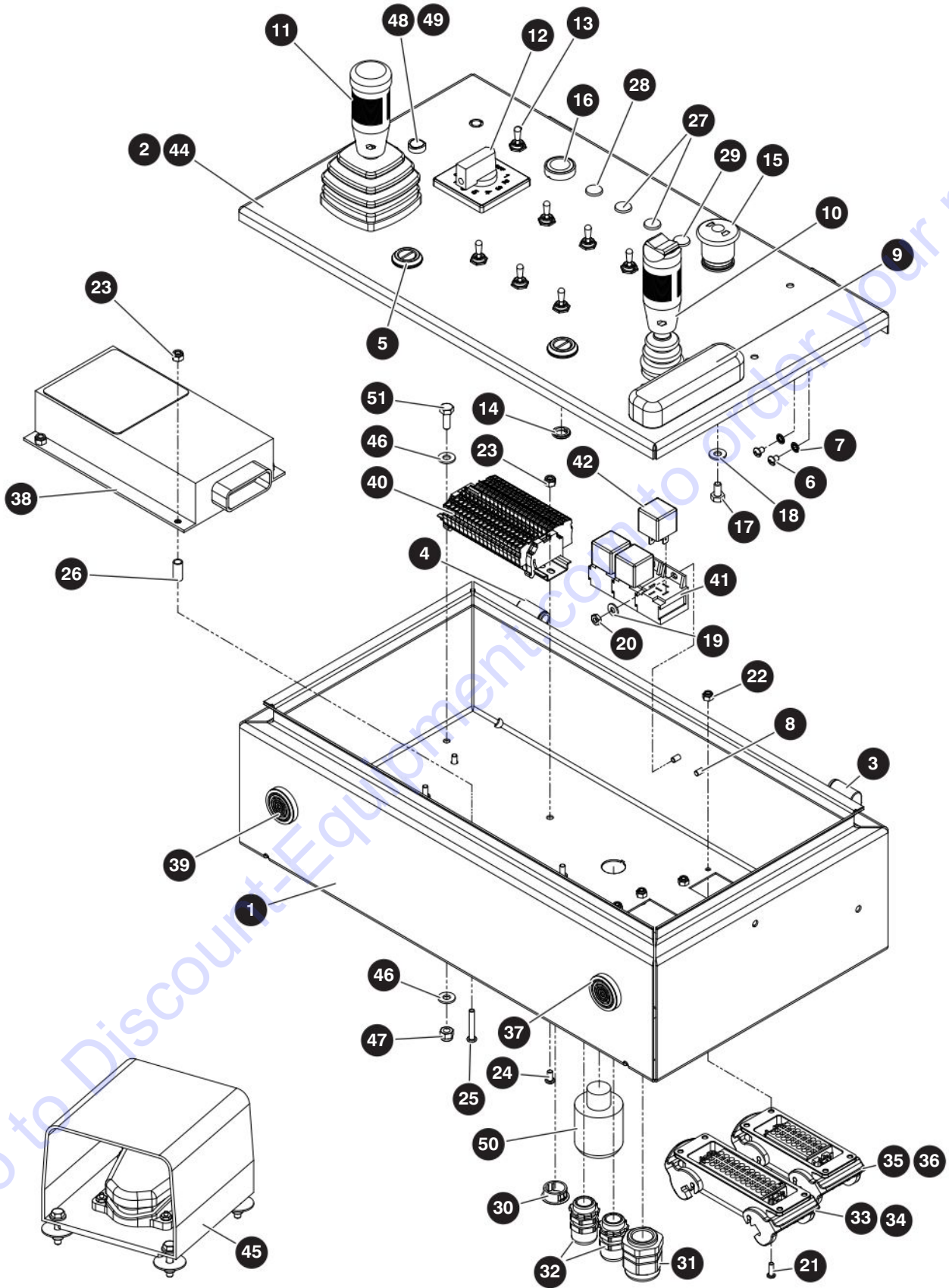

M192560AE

229034ADA

SJ30 AJE, SJ30 ARJE

1.6 Platform Control Box

Index No.	Skyjack Part No.	Qty.	Description
A	218778	1	PLATFORM CONTROL BOX ASSEMBLY - SJ30 ARJE ANSI/CSA
B	192560	1	PLATFORM CONTROL BOX ASSEMBLY - SJ30 ARJE CE & AS
C	208956	1	PLATFORM CONTROL BOX ASSEMBLY - SJ30 ARJE KC
D	218775	1	PLATFORM CONTROL BOX ASSEMBLY - SJ30 AJE ANSI/CSA
-	218321	1	• PLATFORM CONTROL BOX, A
	218321	1	• PLATFORM CONTROL BOX, B
	208957	1	• PLATFORM CONTROL BOX, C
	218323	1	• PLATFORM CONTROL BOX, D
-	192052	1	• • PLATFORM CONTROL BOX, A, B, D
	209044	1	• • PLATFORM CONTROL BOX, C
1	192054	1	• • • BODY, Platform control box
2	192053	1	• • • LID, Platform control box
3	149384	1	• • • HINGE, Nylon - LH
4	149385	1	• • • HINGE, Nylon - RH
5	138715	2	• • • LATCH, Slotted door
6	103959	8	• • • SCREW, Round head machine (#10-32 x 1/4")
7	163512	8	• • • WASHER, Int tooth lock (#10)
8	159879	2	• • • STUD, Pem alum (#10-32 x 0.375")
9	149402	1	• • HANDREST
10	(Ref.)	1	• • CONTROLLER, Drive/Steer (Single Axis) (For components, refer to 1.7 Drive/Steer Controller)
11	(Ref.)	1	• • CONTROLLER, Boom/Turret (Dual Axis) (For components, refer to 1.8 Boom/Turret Controller)
12	138226	1	• • CONTROLLER, Function Speed (Unidirectional)
	198762	1	• • • KNOB, Rotary controller
13	102853	7	• • SWITCH, Toggle
14	144016	7	• • SEAL, Panel bushing
15	144647	1	• • SWITCH, Emergency stop
	147056	1	• • • LATCH, Mounting
	147053	2	• • • BLOCK, NC Contact
	147229	1	• • • SWITCH, LED Block (Red)
	147051	1	• • • SWITCH HEAD, Emergency stop
16	144648	1	• • PUSHBUTTON, Horn
	147056	1	• • • LATCH, Mounting
	147054	1	• • • BLOCK, NO Contact
	147058	1	• • • SWITCH HEAD, Horn pushbutton
17	103855	2	• • BOLT, Hex head (0.25"-20 x 0.50" gr 5)
18	103995	2	• • WASHER, Flat (0.25" SAE)
19	104694	2	• • WASHER, Flat (#10), A, B, D
	104694	3	• • WASHER, Flat (#10), C

1.6 Platform Control Box

Index No.	Skyjack Part No.	Qty.	Description
20	104003	2	• • NUT, Hex (10-32), A, B, D
	104003	3	• • NUT, Hex (10-32), C
21	103957	8	• • SCREW, Round head machine (8-32 x 0.50")
22	138765	8	• • NUT, Lock (8-32 gr 5 nylon)
23	300450	6	• • NUT, Lock (10-32 gr 5 nylon)
24	115545	2	• • SCREW, Round head machine (10-32 x 0.375"), A, B, D
	115545	3	• • SCREW, Round head machine (10-32 x 0.375"), C
25	122498	4	• • SCREW, Round head machine (10-32 x 1.25")
26	128571	4	• • SLEEVE, Anti vibration mount
27	164832	2	• • LIGHT, Indicator - 12V red
28	171501	1	• • LIGHT, Indicator - 14V green
29	171502	1	• • LIGHT, Indicator - 14V amber
30	102956	2	• • PLUG, Snap in for 0.875" hole
31	116266	1	• • CONNECTOR, Strain relief (PG21)
32	103036	2	• • CONNECTOR, Strain relief (0.50" NPT)
33	138751	1	• • HOUSING, Open bottom (24 pole levered)
34	138756	1	• • SOCKET, 24 pole spring 16A
35	192082	1	• • HOUSING, Open bottom (16 pole)
36	192084	1	• • PLUG, Spring (16 pole)
37	144387	1	• • ALARM, Continuous tone
38	192081	1	• • CONTROLLER, Module - SMC32
39	103057	1	• • BEEPER, Slow pulsing (4-28 VDC)
40	192086	1	• • TERMINAL BLOCK ASSEMBLY (4 X 19) (For components, refer to 1.9 Platform Terminal Strip)
41	138749	4	• • SOCKET, Automotive relay, A, B, D
	138749	7	• • SOCKET, Automotive relay, C
42	127131	4	• • RELAY, 12V 40 amp, A, B, D
	127131	7	• • RELAY, 12V 40 amp, C
43	192085	1	• • WIRING ASSEMBLY, Platform controls (not shown), B
	208958	1	• • WIRING ASSEMBLY, Platform controls (not shown), C
	207832	1	• • WIRING ASSEMBLY, Platform controls (not shown), A, D
	102921	10	• • • DIODE, A, B, C
	102921	11	• • • DIODE, D
	192152	1	• • • PLUG, 35 position (blue)
	151643	10	• • • RESISTOR - 250 ohm, A, B, C
	151643	12	• • • RESISTOR - 250 ohm, D
	144492	1	• • • RESISTOR - 650 ohm, D
44	(Ref.)	1	• • LABEL, Platform control box (For components, refer to 9.5 Labels - Platform)

1.6 Platform Control Box

Index No.	Skyjack Part No.	Qty.	Description
45	(Ref.)	1	<ul style="list-style-type: none"> FOOTSWITCH (For components, refer to 1.10 Footswitch)
46	103995	8	<ul style="list-style-type: none"> WASHER, Flat (0.25" SAE)
47	115649	4	<ul style="list-style-type: none"> NUT, Hex head nylon (0.25"-20 gr 5)
48	166086	1	<ul style="list-style-type: none"> BLOCK, Contact - N/O (yellow LED 12-24V)
49	166087	1	<ul style="list-style-type: none"> PUSHBUTTON, Flush spring - yellow
50	166110	1	<ul style="list-style-type: none"> ALARM/FLASHER, 12V - red LED
51	103856	4	<ul style="list-style-type: none"> BOLT, Hex head (0.25"-20 x 0.75" gr 5)

1.7 Drive/Steer Controller

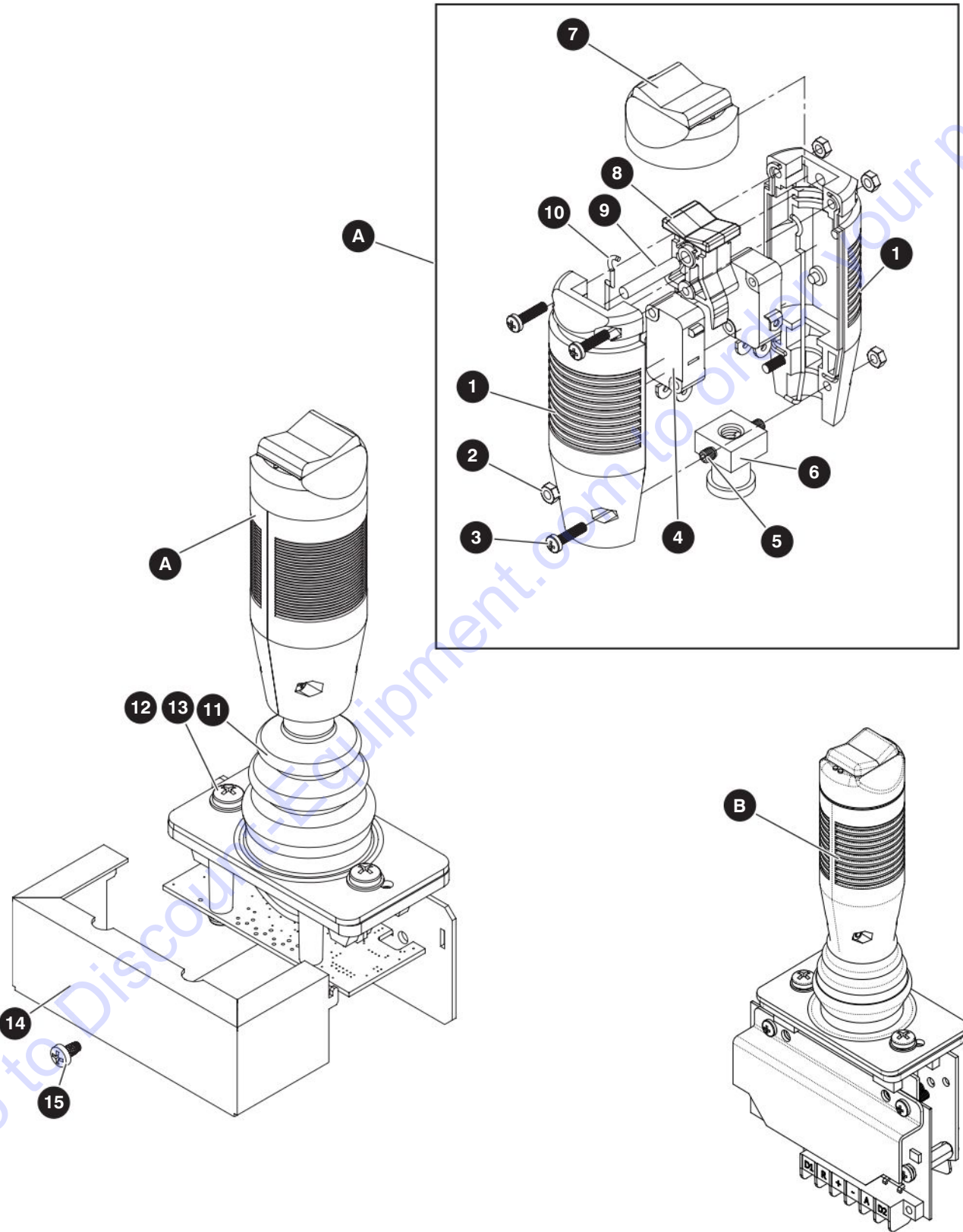

M138224AA_M220627AA

229034ADA

SJ30 AJE, SJ30 ARJE

1.7 Drive/Steer Controller

Index No.	Skyjack Part No.	Qty.	Description
A	138224	1	DRIVE / STEER CONTROLLER (SINGLE AXIS)
1	141338	2	• HANDLE, Half
2	141328	4	• NUT
3	141329	4	• SCREW
4	141342	2	• MICROSWITCH
5	141331	2	• SCREW, Set
6	141343	1	• COUPLING, (8 MM)
7	141339	1	• CAP, Rubber
8	141340	1	• ROCKER
9	141341	1	• ROCKER, Axle
10	141327	2	• GASKET
11	141334	1	• BOOT ASSEMBLY, Standard
12	141336	2	• SCREW Mounting
13	141335	2	• WASHER, Mounting
14	141333	1	• ENCLOSURE
15	141337	1	• SCREW, Enclosure
B	220627	1	DRIVE / STEER CONTROLLER (SINGLE AXIS) - Potentiometer style - Optional

1.8 Boom/Turret Controller

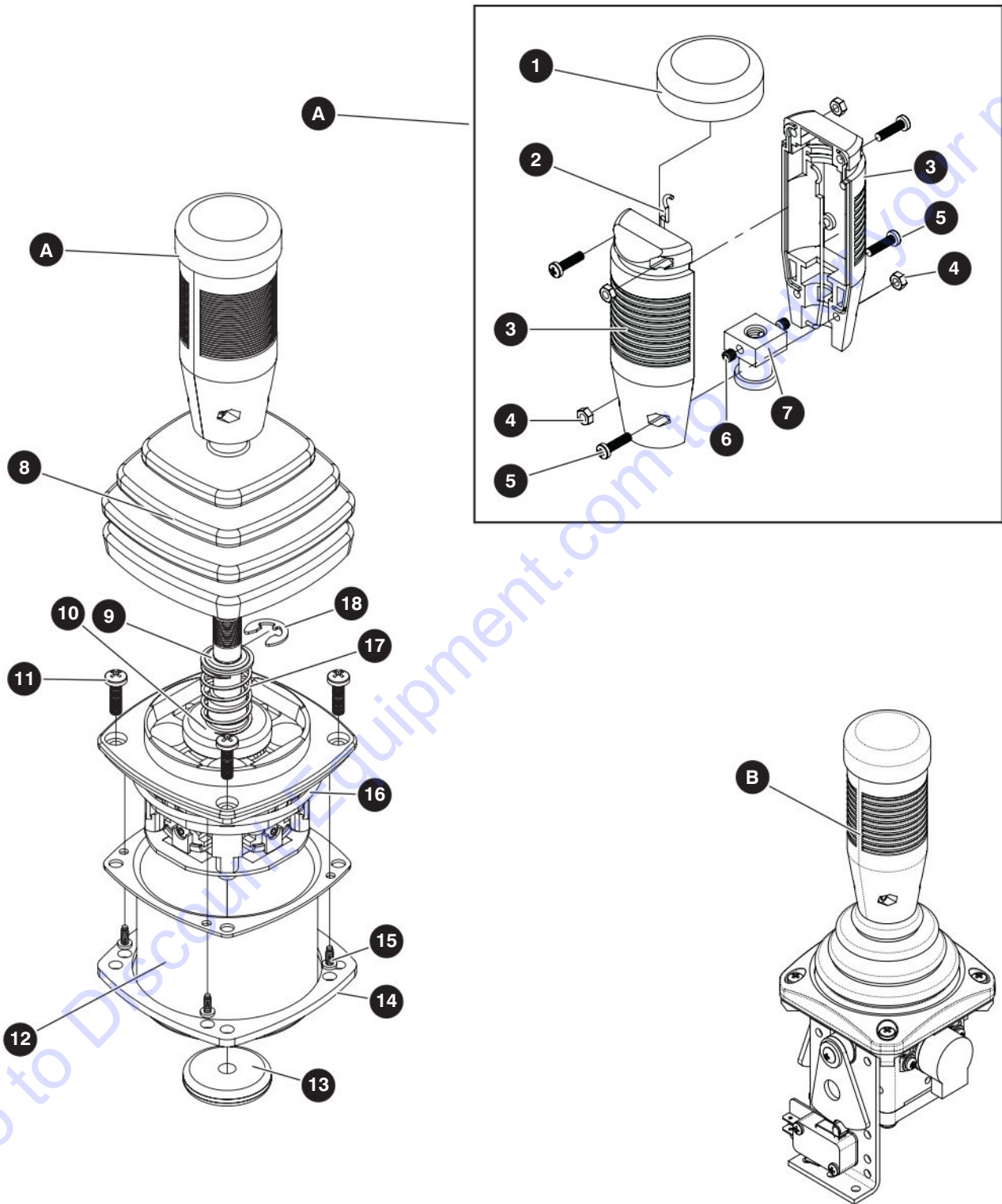

M138225AA_M220628AA

229034ADA

SJ30 AJE, SJ30 ARJE

1.8 Boom/Turret Controller

Index No.	Skyjack Part No.	Qty.	Description
A	138225	1	BOOM/TURRET CONTROLLER (DUAL AXIS)
1	141326	1	• CAP, Rubber
2	141327	2	• GASKET
3	141325	2	• HANDLE, Half
4	141328	4	• NUT
5	141329	4	• SCREW
6	141331	2	• SCREW, Set
7	141330	1	• COUPLING, (10 mm)
8	141313	1	• BOOT
9	141323	1	• WASHER, Retainer
10	141315	1	• SHOE, Spring
11	141321	4	• SCREW, Mounting (M4)
12	141316	1	• CAN, Enclosure
13	141320	1	• GROMMET, Rubber
14	141317	1	• GASKET, Mounting
15	141319	4	• SCREW
16	141318	1	• O-RING
17	141324	1	• SPRING, Compression
18	141322	1	• CLIP, Retainer
B	220628	1	BOOM / TURRET CONTROLLER (DUAL AXIS) - Potentiometer style - Optional

1.9 Platform Terminal Strip

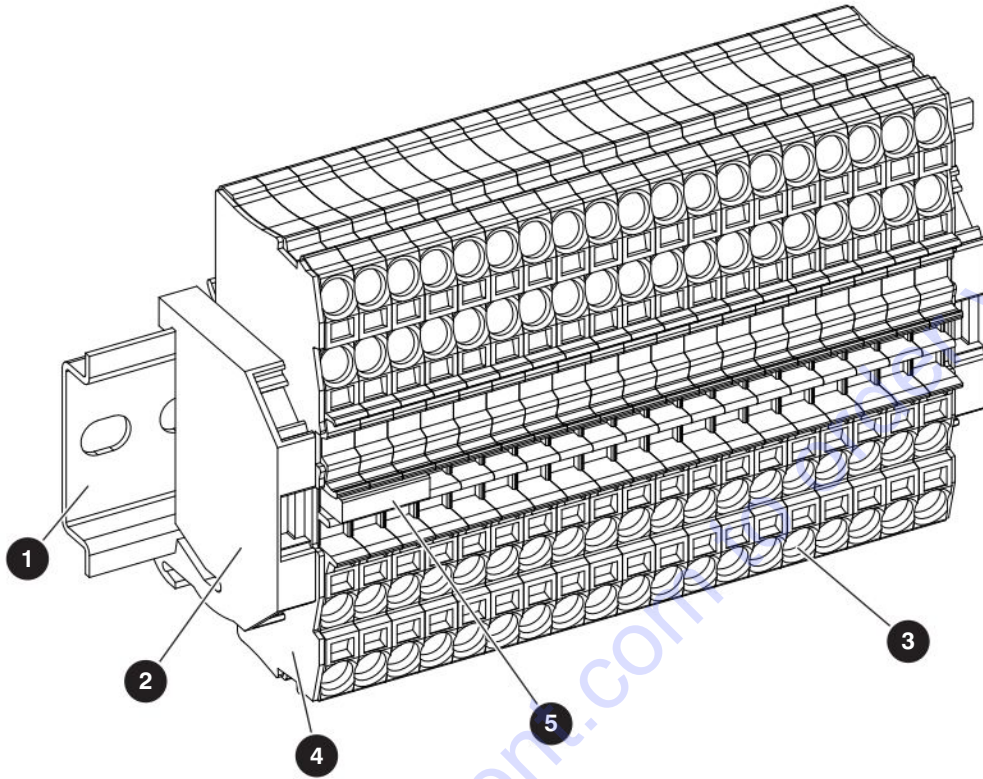

M192086AB

Index No.	Skyjack Part No.	Qty.	Description
-	192086	1	PLATFORM TERMINAL STRIP
1	102874	7"	<ul style="list-style-type: none"> • TRACK, Terminal
2	707147	2	<ul style="list-style-type: none"> • STOP, End
3	137940	22	<ul style="list-style-type: none"> • BLOCK, Terminal
4	137941	2	<ul style="list-style-type: none"> • PLATE, End
5	137943	1	<ul style="list-style-type: none"> • JUMPER, 3 pin

1.10 Footswitch

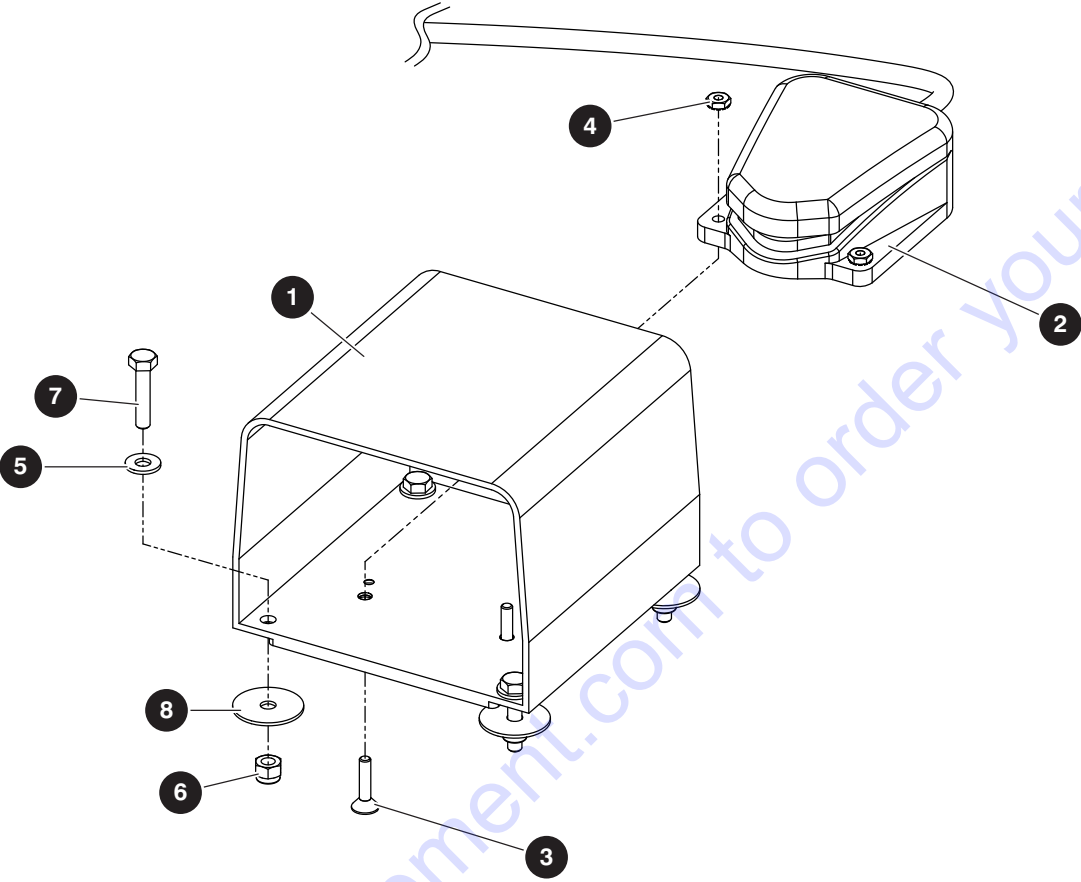

M192560AA_FS

Index No.	Skyjack Part No.	Qty.	Description
-	154127	1	FOOTSWITCH
1	700188	1	• COVER, Footswitch
2	700187	1	• SWITCH, Foot
3	139688	2	• SCREW, Flat head machine (0.25"-20 x 1.00")
4	130017	2	• NUT, K-Lock (10-32)
5	103995	4	WASHER, Flat (0.25" SAE)
6	115649	4	NUT, Hex head nylon (0.25"-20 gr 5)
7	103858	4	BOLT, Hex head (0.25"-20 x 1.25" gr 5)
8	700598	4	WASHER, Fender (0.25")

1.11 SGE

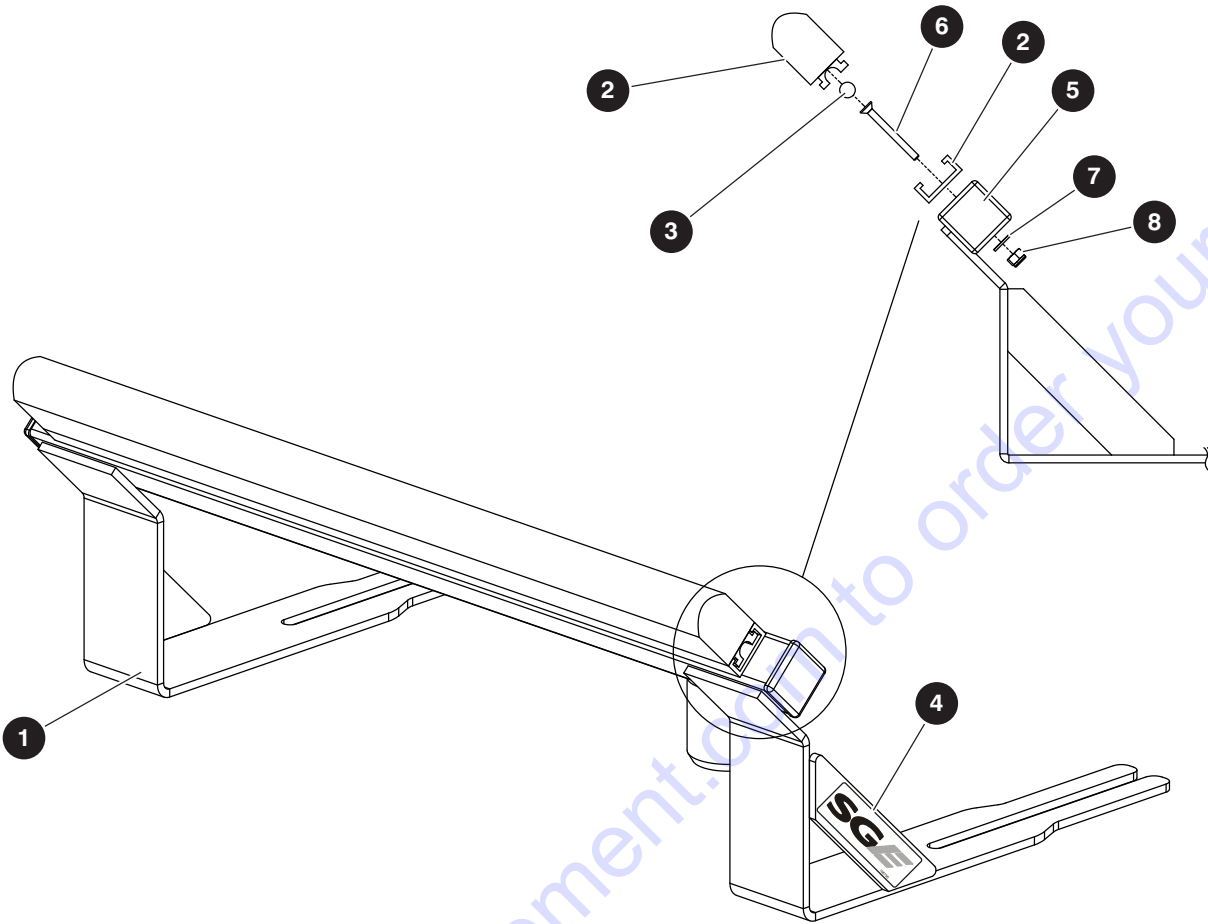

M192146AD

Index No.	Skyjack Part No.	Qty.	Description
-	192146	1	SECONDARY GUARDING - ELECTRICAL (SGE) - ANSI/CSA, CE & AS For SGE Option on KC , refer to 8.8 Secondary Guarding - Electrical (SGE) - KC
1	192149	1	• BRACKET, SGE sensor
2	192151	1	• EDGE, Sensing (21" modified rail)
3	192154	1	• ROD, Sensing edge lock (21")
4	166756	2	• LABEL, SGE (black/grey)
5	100702	2	• PLUG, Tube (1.52" x 1.25")
6	166105	3	• BOLT, Flat head cap screw (10-32 x 1.75" gr 5)
7	104694	3	• WASHER, Flat (#10)
8	300450	3	• NUT, Lock (10-32 gr 5 nylon)

1.12 Power Outlet 110 V - ANSI/CSA

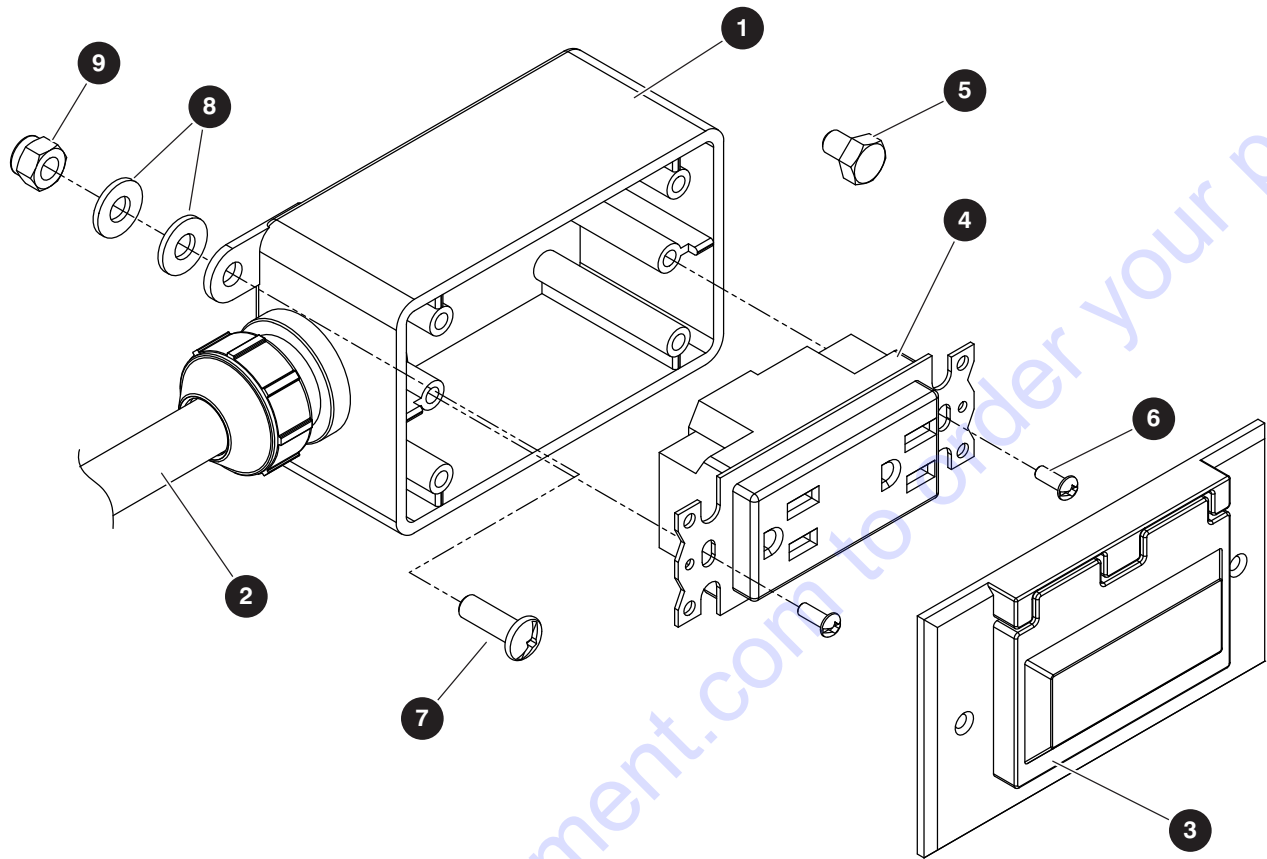

M192711AD

Index No.	Skyjack Part No.	Qty.	Description
A	192711	1	110V OUTLET CABLE - ANSI/CSA
1	136328	1	• BOX, 110 Outlet
2	192185	1	• CABLE, 110V (590")
3	109699	1	• PLATE, Receptacle
4	109698	1	• RECEPTACLE, GFI
5	112495	1	• BOLT, Hex head (0.25"-20 x 0.375" gr 5)
6	121461	2	• SCREW, Round head machine (6-32 x 0.375")
7	103965	2	• SCREW, Round head machine (0.25"-20 x 0.75")
8	103995	4	• WASHER, Flat (0.25" SAE)
9	115649	2	• NUT, Lock (0.25"-20 gr 5 nylon)

1.13 Power to Platform - Outlet and Plugs - CE

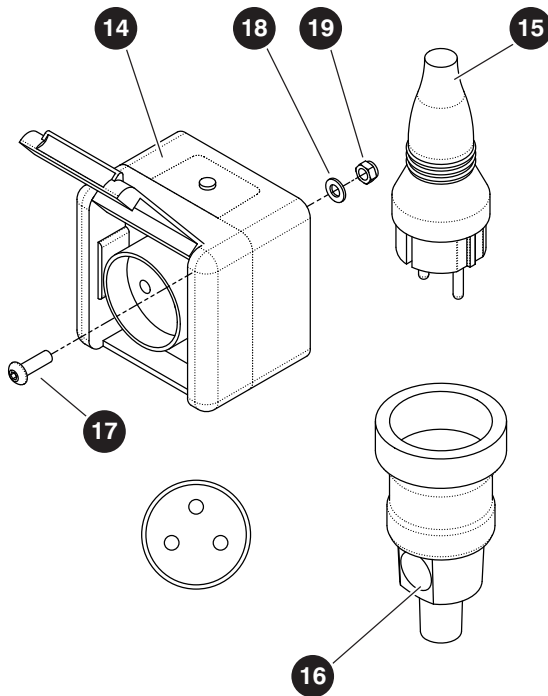
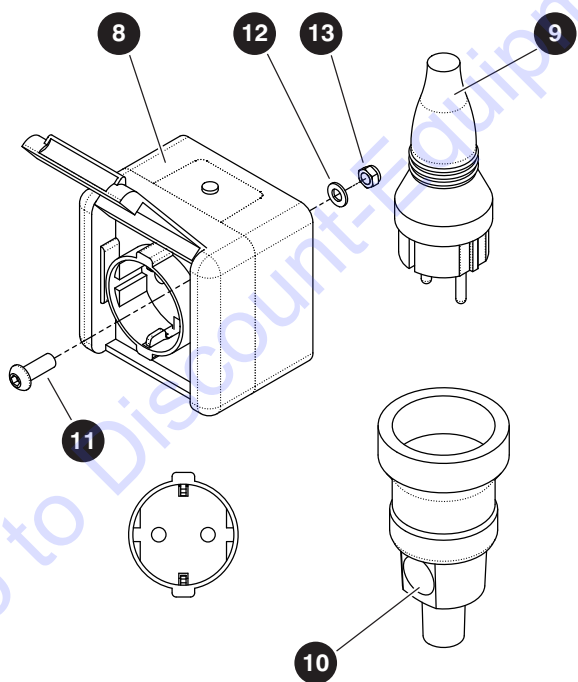
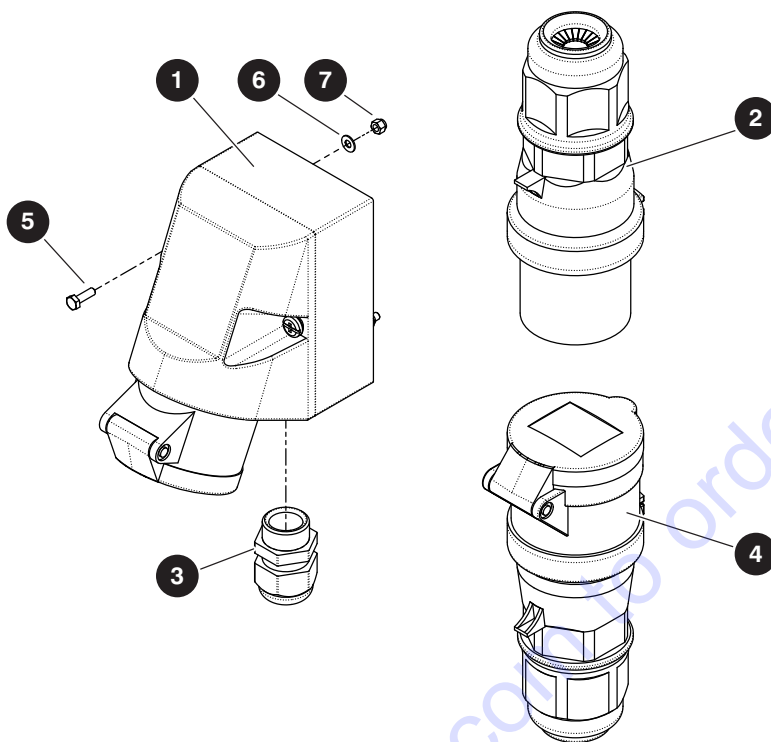

M226505AA_M226509AA_M226513AA

229034ADA

SJ30 AJE, SJ30 ARJE

1.13 Power to Platform - Outlet and Plugs - CE

Index No.	Skyjack Part No.	Qty.	Description
A	226505	1	POWER TO PLATFORM OUTLET - UK with generator
B	226507	1	POWER TO PLATFORM OUTLET - UK no generator
1	226503	1	<ul style="list-style-type: none"> • RECEPTACLE, 16 amp 110 VAC 2P+E
2	226501	1	<ul style="list-style-type: none"> • PLUG, 16 amp 110 VAC 2P+E
3	138373	1	<ul style="list-style-type: none"> • STRAIN RELIEF, M20
4	226502	1	<ul style="list-style-type: none"> • RECEPTACLE, 16 amp 110 VAC 2P+E, A
5	228463	2	<ul style="list-style-type: none"> • BOLT, Hex head (M3 x 0.5 x 10, cl 8.8)
6	600579	2	<ul style="list-style-type: none"> • WASHER, Flat (M4)
7	217626	2	<ul style="list-style-type: none"> • NUT, Hex head nylon lock (M3 x 0.5, cl 8)
C	226509	1	POWER TO PLATFORM OUTLET - Type F with generator
D	226511	1	POWER TO PLATFORM OUTLET - Type F no generator
8	226454	1	<ul style="list-style-type: none"> • OUTLET, Socket - 16 amp 250 V
9	157192	1	<ul style="list-style-type: none"> • PLUG, 250 V
10	226504	1	<ul style="list-style-type: none"> • RECEPTACLE, 250 V 16 amp, C
11	228459	2	<ul style="list-style-type: none"> • BOLT, Hex head (M5 x 0.8 x 16, cl 10.9)
12	933816	2	<ul style="list-style-type: none"> • WASHER, Flat (M5)
13	217628	2	<ul style="list-style-type: none"> • NUT, Hex head nylon lock (M5 x 0.8, cl 8)
E	226513	1	POWER TO PLATFORM OUTLET - Type E with generator
F	226515	1	POWER TO PLATFORM OUTLET - Type E no generator
14	226455	1	<ul style="list-style-type: none"> • OUTLET, Socket - 16 amp 250 V
15	157192	1	<ul style="list-style-type: none"> • PLUG, 250 V
16	226504	1	<ul style="list-style-type: none"> • RECEPTACLE, 250 V 16 amp, E
17	228459	2	<ul style="list-style-type: none"> • BOLT, Hex head (M5 x 0.8 x 16, cl 10.9)
18	933816	2	<ul style="list-style-type: none"> • WASHER, Flat (M5)
19	217628	2	<ul style="list-style-type: none"> • NUT, Hex head nylon lock (M5 x 0.8, cl 8)
-	208024	1	220V OUTLET CABLE (590") (not shown)

Section 2 – Boom

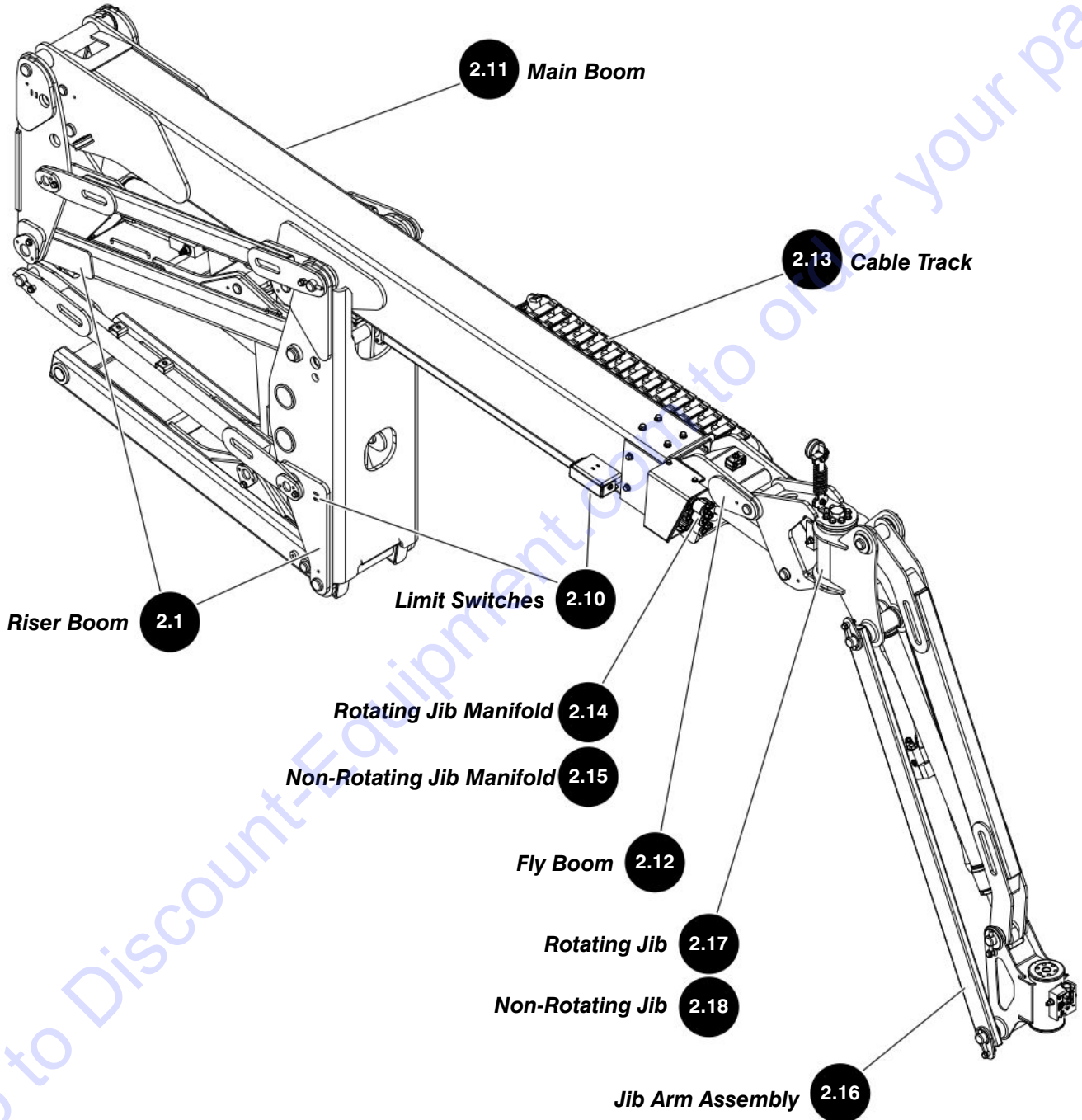

2.1 Riser Boom

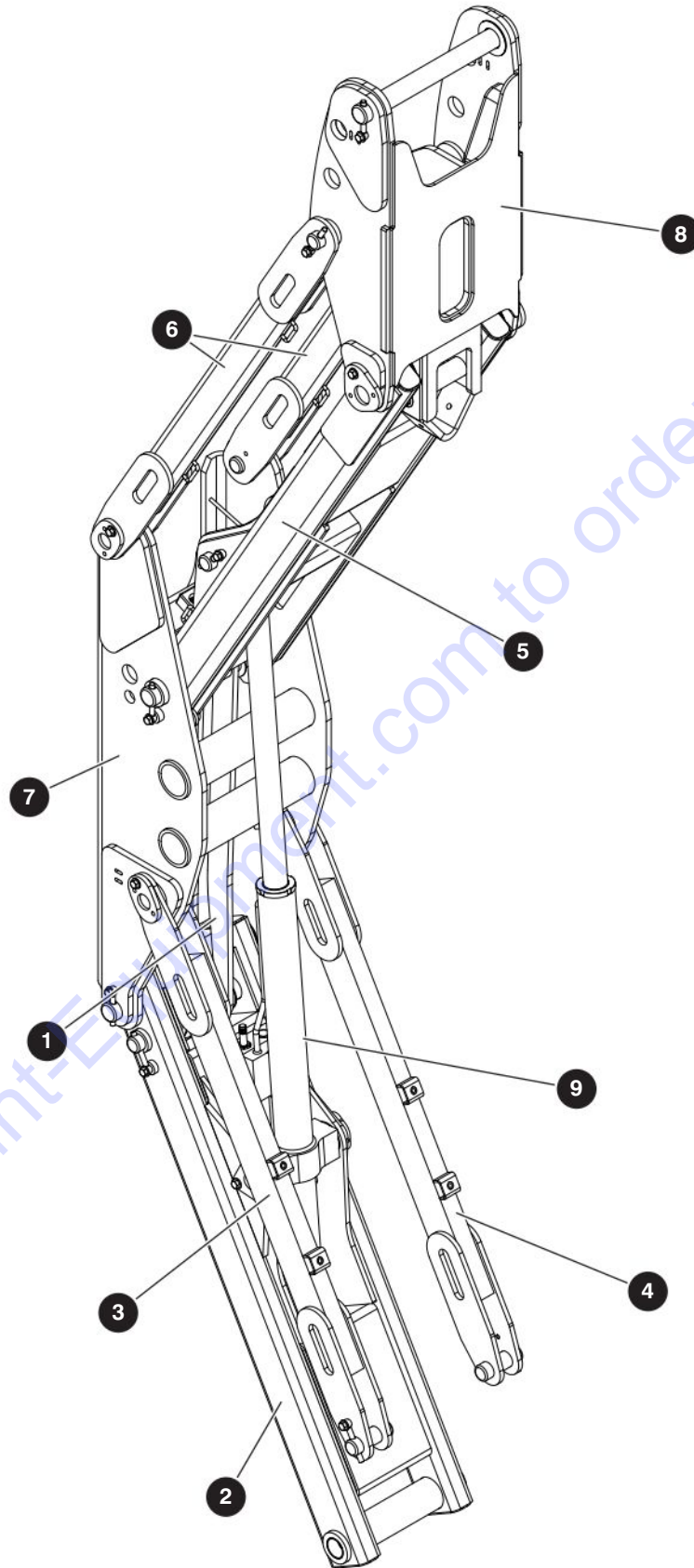

M192990AC

229034ADA

40

SJ30 AJE, SJ30 ARJE

SKYJACK

2.1 Riser Boom

Index No.	Skyjack Part No.	Qty.	Description
-	192990	1	RISER BOOM ASSEMBLY
1	192895	1	<ul style="list-style-type: none"> ARM ASSEMBLY, Link (For components, refer to 2.2 Link Arm)
2	192894	1	<ul style="list-style-type: none"> ARM ASSEMBLY, Lower riser (For components, refer to 2.3 Lower Riser Arm)
3	192674	1	<ul style="list-style-type: none"> ARM ASSEMBLY, 2nd riser - right (For components, refer to 2.4 2nd Riser Arm - Right)
4	192415	1	<ul style="list-style-type: none"> ARM ASSEMBLY, 2nd riser - left (For components, refer to 2.5 2nd Riser Arm - Left)
5	192896	1	<ul style="list-style-type: none"> ARM ASSEMBLY, 3rd riser (For components, refer to 2.6 3rd Riser Arm)
6	192989	2	<ul style="list-style-type: none"> ARM ASSEMBLY, Upper riser (For components, refer to 2.7 Upper Riser Arm)
7	192893	1	<ul style="list-style-type: none"> KNUCKLE, Lower (For components, refer to 2.8 Lower Knuckle)
8	192898	1	<ul style="list-style-type: none"> KNUCKLE, Upper (For components, refer to 2.9 Upper Knuckle)
9	192130	1	<ul style="list-style-type: none"> CYLINDER, Riser (For components, refer to 3.1 Riser Cylinder)

2.2 Link Arm

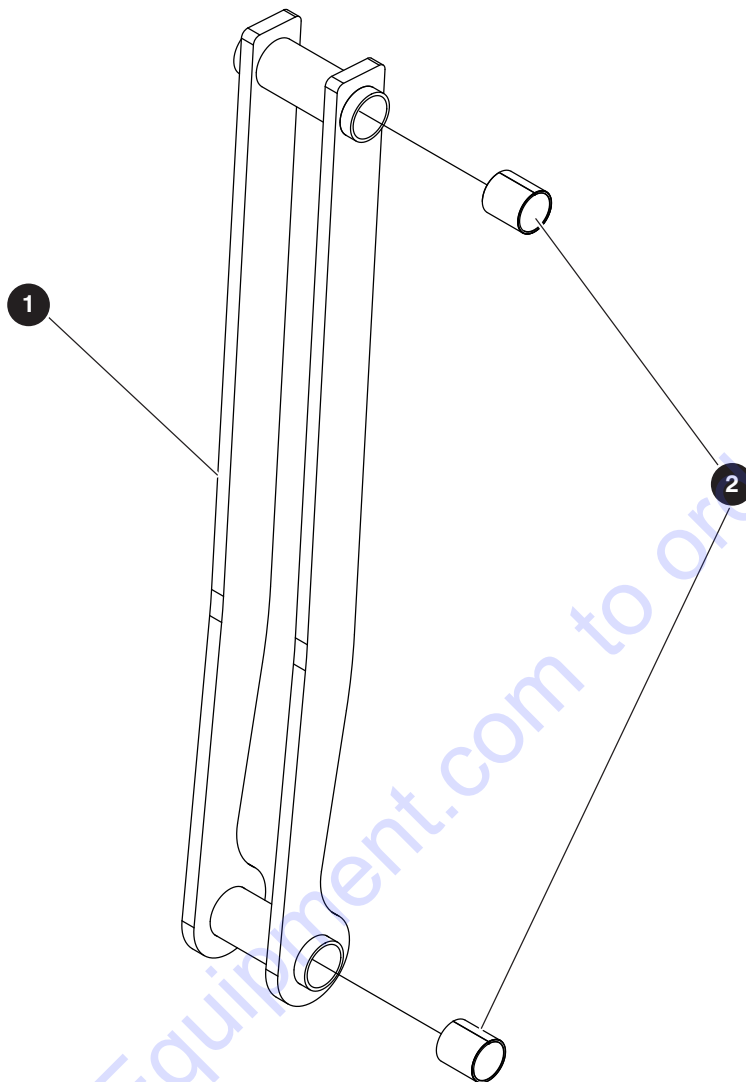

M192895AA

Index No.	Skyjack Part No.	Qty.	Description
-	192895	1	ARM ASSEMBLY, Link
1	230268	1	• ARM WELMENT, Link
2	125262	4	• BUSHING, CJS 2024 (1.25" ID x 1.50" LG)

2.3 Lower Riser Arm

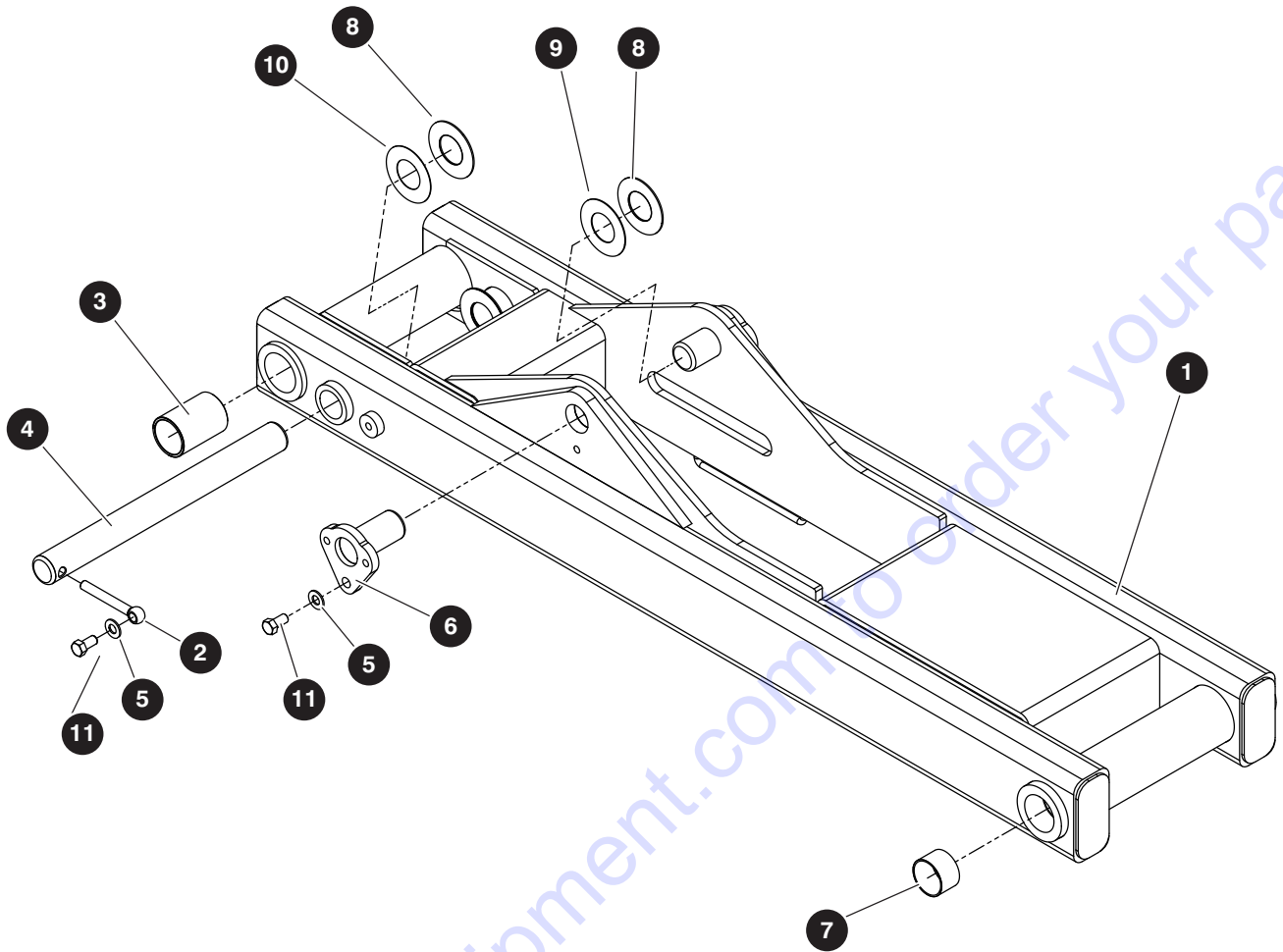

M192894AC

Index No.	Skyjack Part No.	Qty.	Description
-	192894	1	ARM ASSEMBLY, Lower riser
1	230271	1	• ARM WELDMENT, Lower riser
2	146897	1	• PIN, Keeper (0.375")
3	192284	2	• BEARING, Self lube (1.7539" OD x 1.5087" ID x 2.5" LG)
4	192458	1	• PIN, Boom (1.25" dia x 13.30" lg)
5	103472	3	• WASHER, Flat (0.375" SAE)
6	192987	2	• PIN
7	100904	4	• BEARING, Plain (1.50" ID x 1.625" OD x 1.00" FG)
8	192970	4	• SHIM, Pin (0.060" 1GA)
9	192969	2	• SHIM, Pin (0.036" (20 GA)
10	192968	2	• SHIM, Pin (0.020" 25 GA)
11	101632	3	• BOLT, Hex head (0.375"-16 x 0.75" gr 5)

2.4 2nd Riser Arm - Right

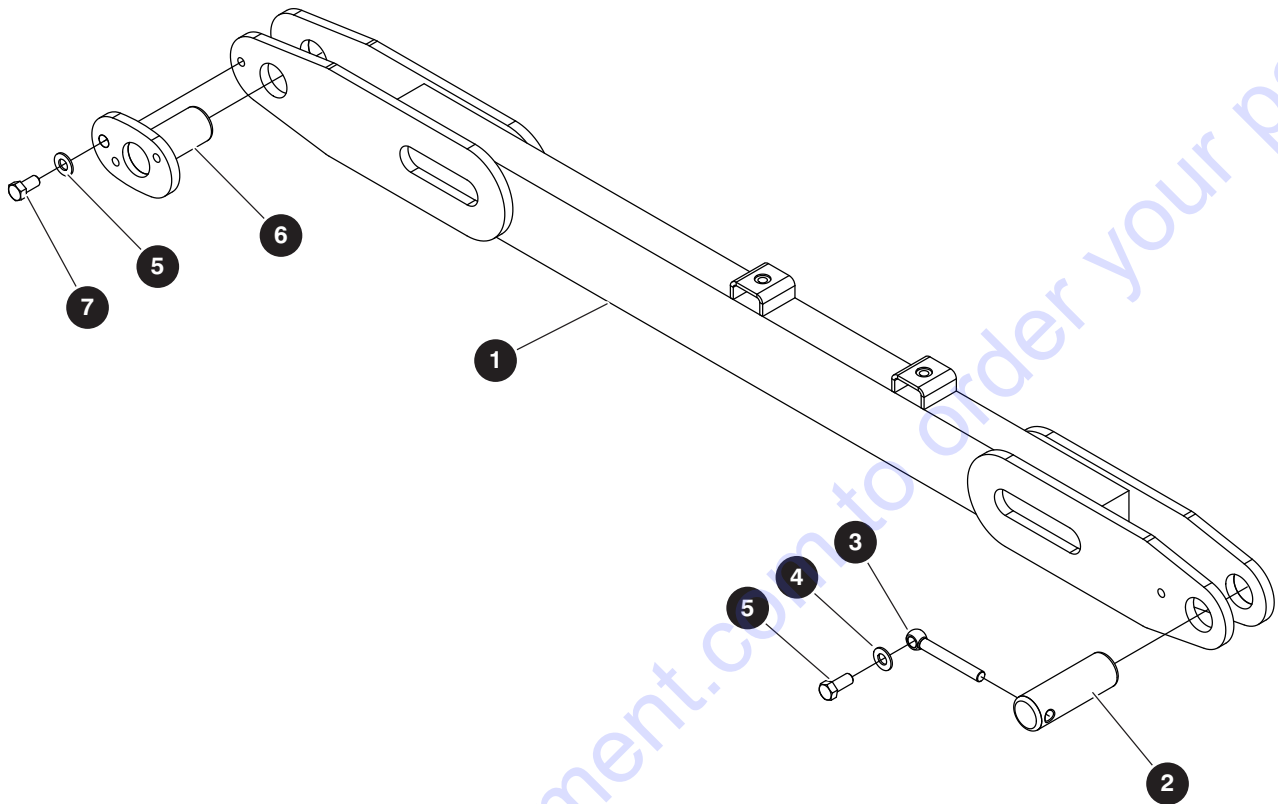

M192674AD

Index No.	Skyjack Part No.	Qty.	Description
-	192674	1	ARM ASSEMBLY, 2nd riser - right
1	226354	1	• ARM WELDMENT, 2nd riser right
2	165192	1	• PIN (1.25" dia x 3.75" lg)
3	146897	1	• PIN, Keeper (0.375")
4	103472	2	• WASHER, Flat (0.375" SAE)
5	300437	1	• BOLT, Hex head (0.375"-16 x 0.875" gr 5)
6	192785	1	• PIN
7	101632	1	• BOLT, Hex head (0.375"-16 x 0.75" gr 5)

2.5 2nd Riser Arm - Left

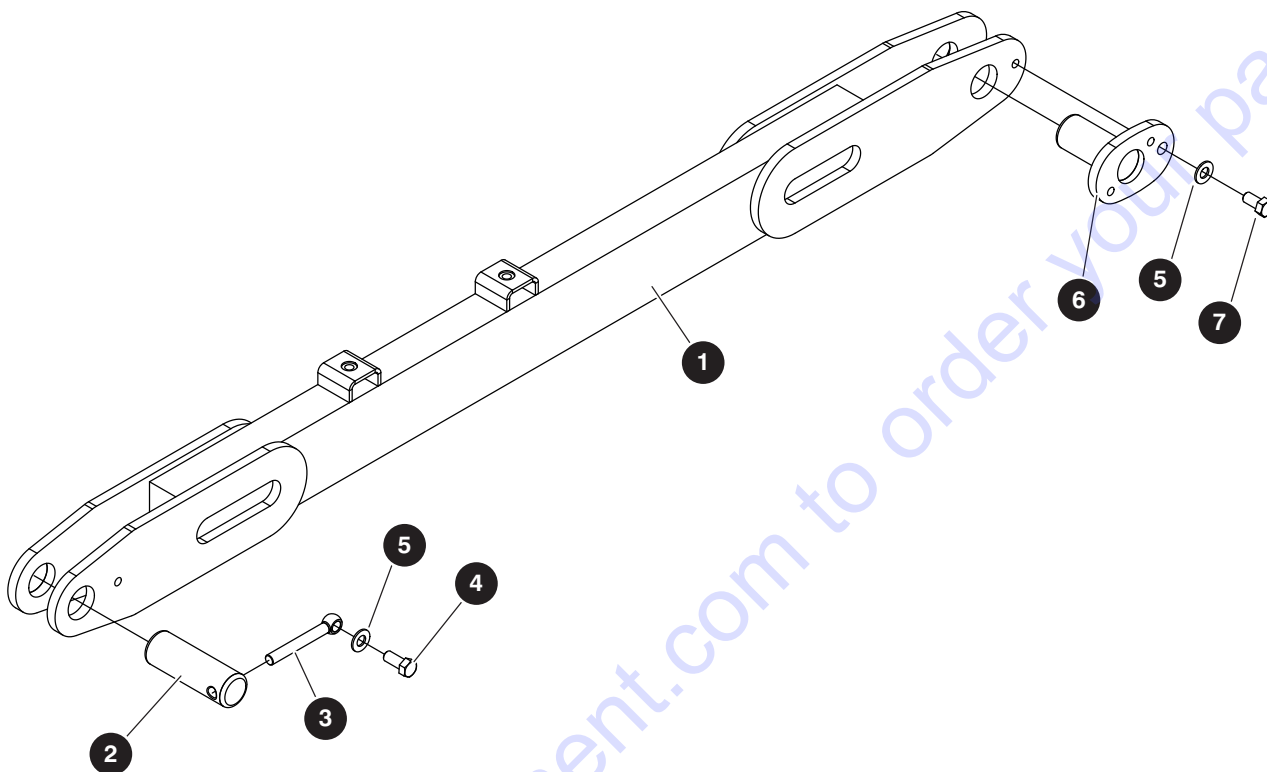

M192415AC

Index No.	Skyjack Part No.	Qty.	Description
-	192415	1	ARM ASSEMBLY, 2nd riser - left
1	226352	1	• ARM WELDMENT, 2nd riser left
2	165192	1	• PIN (1.25" x 3.75" lg)
3	146897	1	• PIN, Keeper (0.375")
4	300437	1	• BOLT, Hex head (0.375"-16 x 0.875" gr 5)
5	103472	2	• WASHER, Flat (0.375" SAE)
6	192785	1	• PIN
7	101632	1	• BOLT, Hex head (0.375"-16 x 0.75" gr 5)

2.6 3rd Riser Arm

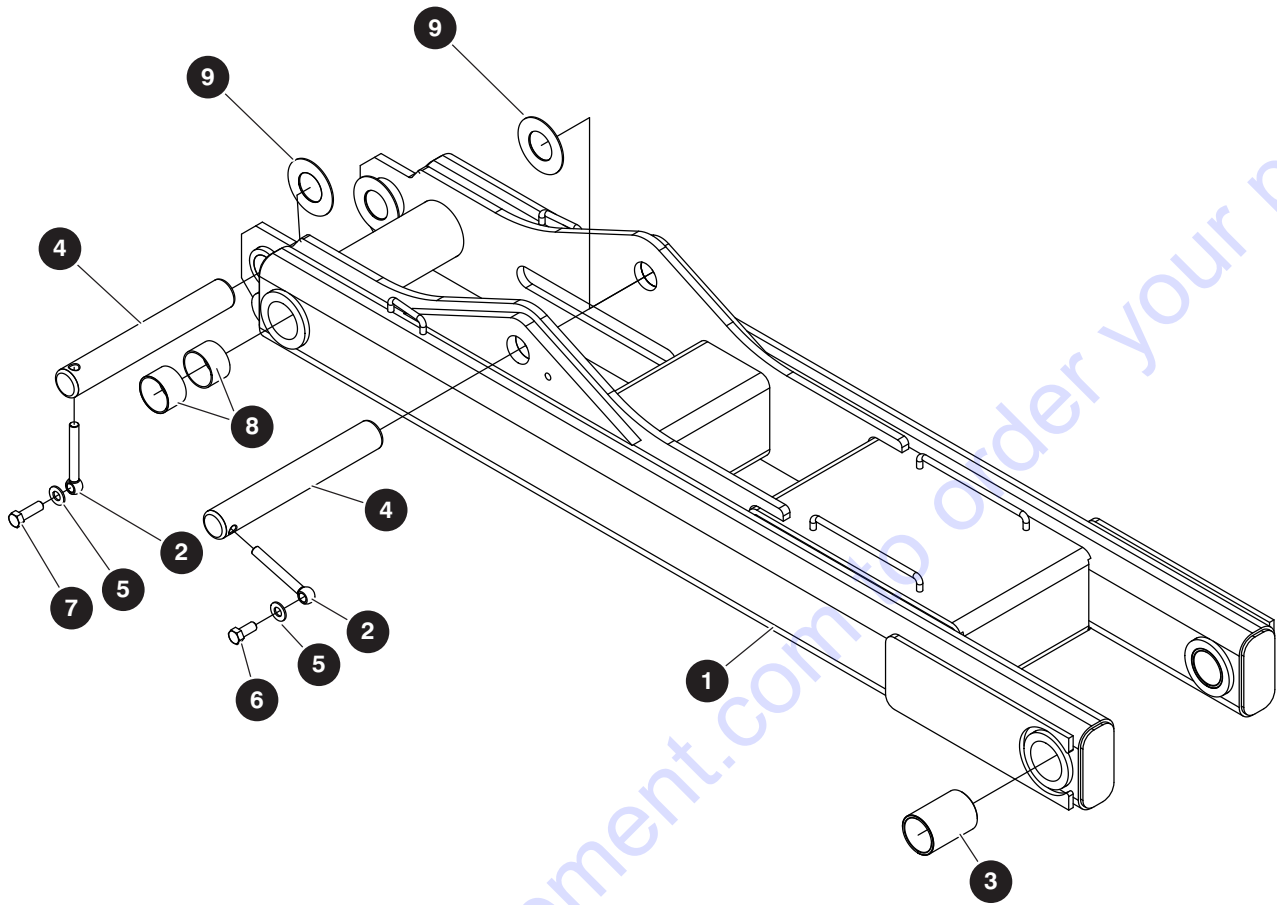

M192896AC

Index No.	Skyjack Part No.	Qty.	Description
-	192896	1	ARM ASSEMBLY, 3rd riser
1	230267	1	• ARM WELDMENT, 3rd riser
2	146897	2	• PIN, Keeper (0.375")
3	192284	2	• BEARING, Self lube (1.7539" OD x 1.5087" ID x 2.5" LG)
4	148844	2	• PIN, Boom (1.25" dia x 9.00" lg)
5	103472	2	• WASHER, Flat (0.375" SAE)
6	300437	1	• BOLT, Hex head (0.375"-16 x 0.875" gr 5)
7	101297	1	• BOLT, Hex head (0.375"-16 x 1.25" gr 5)
8	100904	4	• BEARING, Plain (0.50" ID x 1.625" OD x 1.00" FG)
9	192970	4	• SHIM, Pin (0.060" 16GA)

2.7 Upper Riser Arm

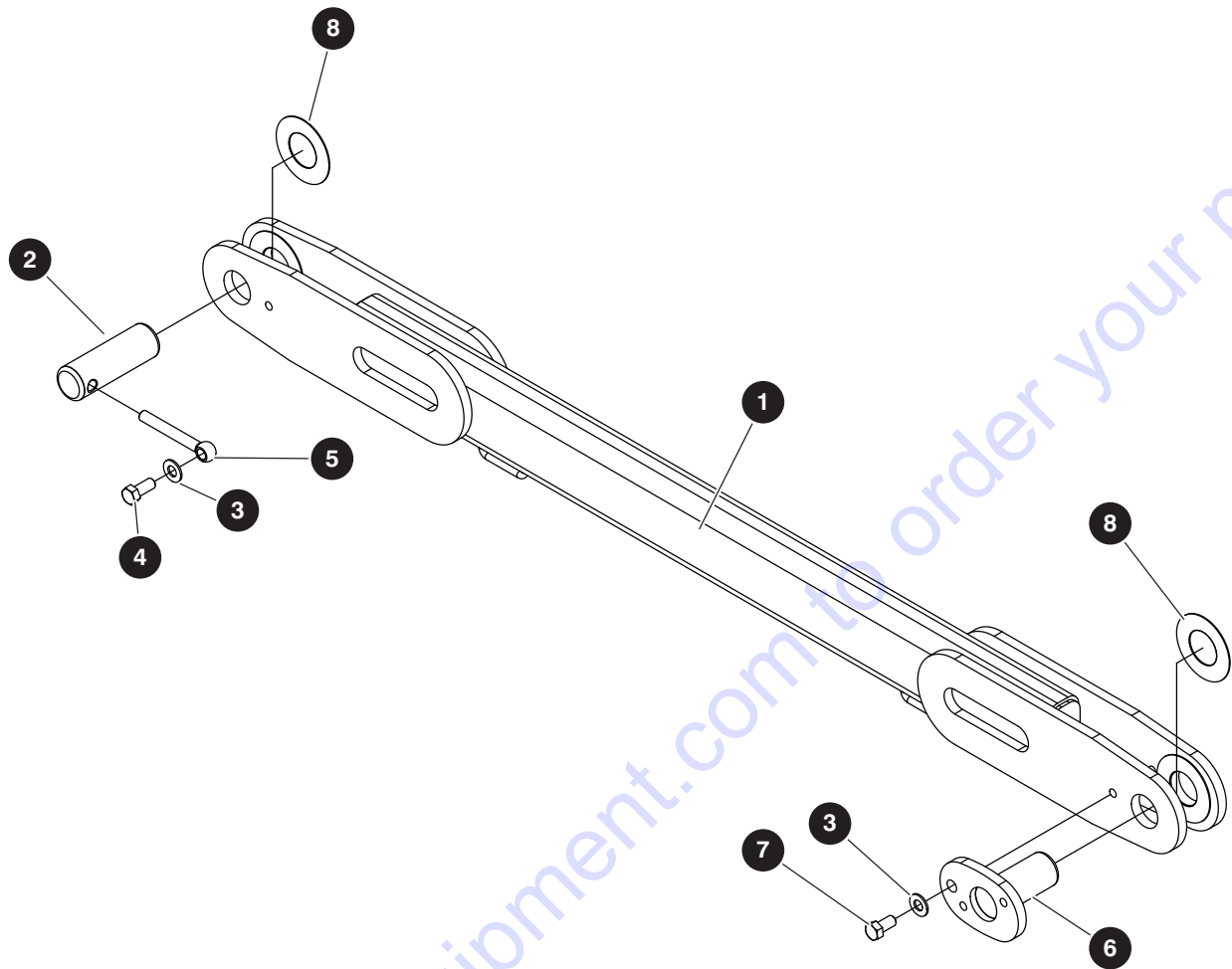

M192989AD

Index No.	Skyjack Part No.	Qty.	Description
-	192989	1	ARM ASSEMBLY, Upper riser
1	226353	1	• ARM WELDMENT, Upper riser
2	165192	1	• PIN (1.25" dia x 3.75" lg)
3	103472	2	• WASHER, Flat (0.375" SAE)
4	300437	1	• BOLT, Hex head (0.375"-16 x 0.875" gr 5)
5	146897	1	• PIN, Keeper (0.375")
6	192785	1	• PIN
7	101632	1	• BOLT, Hex head (0.375"-16 x 0.75" gr 5)
8	192969	4	• SHIM, Pin (0.036" 20GA)

2.8 Lower Knuckle

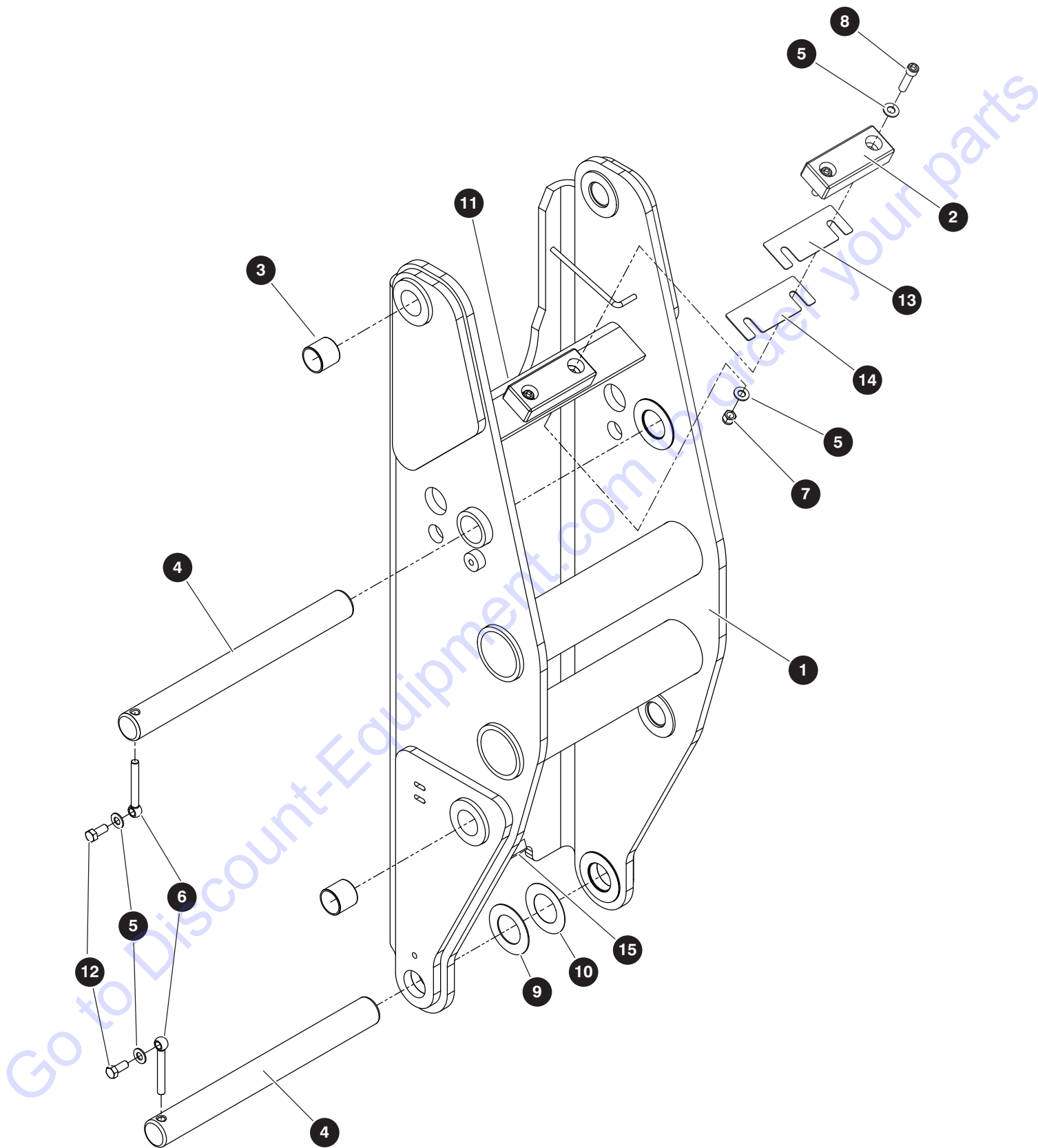

M192893AD

229034ADA

48

SJ30 AJE, SJ30 ARJE

SKYJACK

2.8 Lower Knuckle

Index No.	Skyjack Part No.	Qty.	Description
-	192893	1	LOWER KNUCKLE
1	230265	1	• WELDMENT, Lower knuckle
2	192491	1	• PAD, Riser resr
3	100071	4	• BUSHING, Fiberglide
4	192459	2	• PIN (1.50" x x15.00" lg)
5	103472	6	• WASHER, Flat (0.375" SAE)
6	146897	2	• PIN, Keeper (0.375")
7	104606	2	• NUT, Lock (0.375"-16 gr 5 nylon)
8	103938	2	• SCREW, Socket head cap (0.375"-16 x 1.50")
9	192973	4	• SHIM, Pin (0.060" 16GA)
10	192971	4	• SHIM, Pin (0.020" 25 GA)
11	119922	11"	• TRIM, Protective (0.25"-0.50")
12	300437	2	• BOLT, Hex head (0.375"-16 x 0.875" gr 5)
13	192704	1	• SHIM, Pad - riser rest (0.036 20GA)
14	192703	1	• SHIM, Pad - riser rest (0.063 16GA)
15	196566	6"	• TRIM, Protective (0.50" to 0.625")

2.9 Upper Knuckle

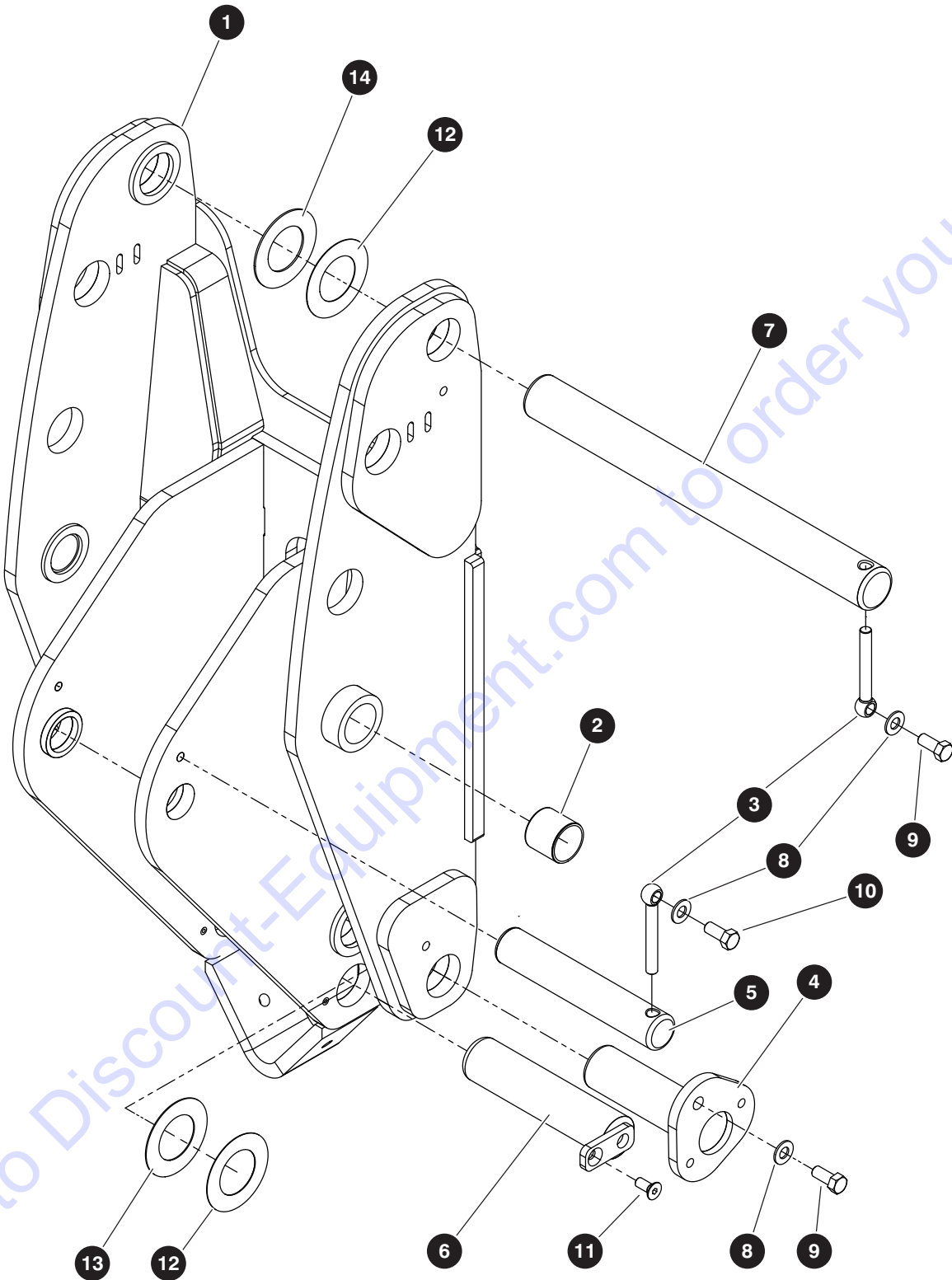

M192898AE

229034ADA

50

SJ30 AJE, SJ30 ARJE

SKYJACK

2.9 Upper Knuckle

Index No.	Skyjack Part No.	Qty.	Description
-	192898	1	UPPER KNUCKLE
1	230269	1	• WELDMENT, Upper knuckle
2	100071	2	• BUSHING, Fiberglide
3	146897	2	• PIN, Keeper (0.375")
4	192788	2	• PIN
5	192464	1	• PIN, Boom (1.25" dia x 7.00" lg)
6	192461	1	• PIN (1.50" dia x 6.625" lg)
7	192459	1	• PIN (1.50" x x15.00" lg)
8	103472	4	• WASHER, Flat (0.375" SAE)
9	125741	3	• BOLT, Hex head (0.375"-16 x 0.875" gr 8)
10	103473	1	• BOLT, Hex head (0.375"-16 x 1.00" gr 5)
11	704642	1	• SCREW, Flat head cap (0.312"-18 x 0.75" gr 5)
12	192971	6	• SHIM, Pin (0.20" 25 GA)
13	192972	4	• SHIM, Pin (0.036" 20GA)
14	192973	2	• SHIM, Pin (0.060" 16GA)

2.10 Limit Switches

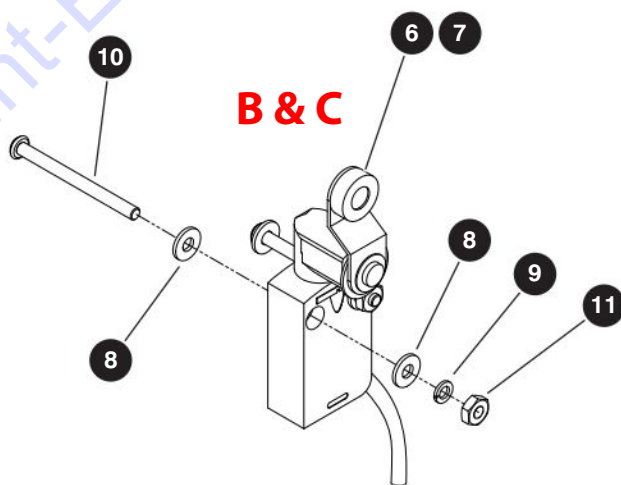
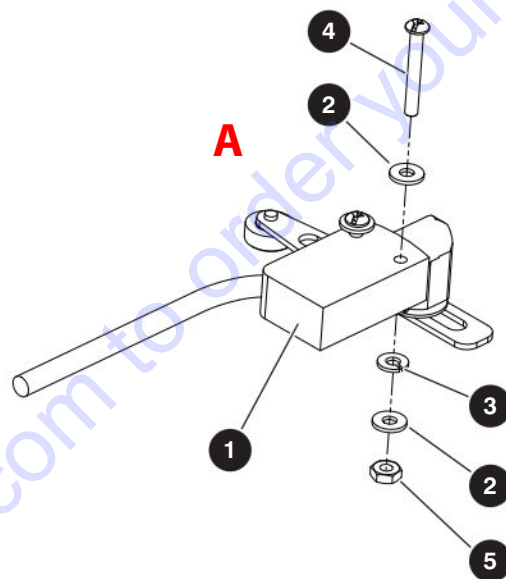
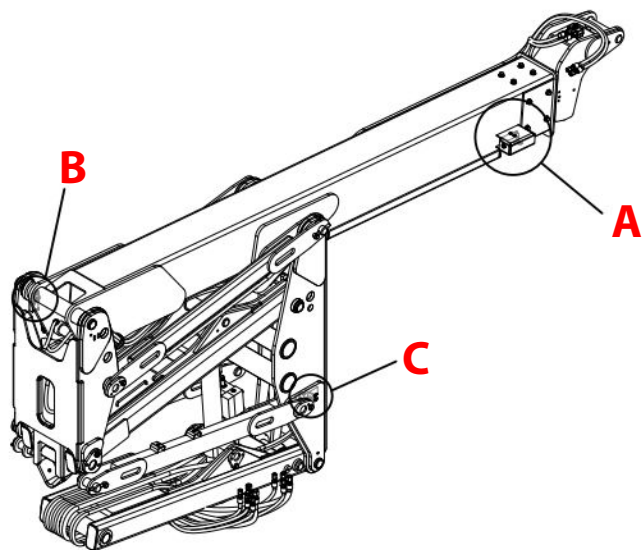

M192178AC_M192177AD

229034ADA

SJ30 AJE, SJ30 ARJE

PARTS FINDER

**Search Website
by Part Number**



**Search Manual
Library For Parts
Manual & Lookup Part
Numbers – Purchase
or Request Quote**

Search Manuals

Enter your information to help us find the right parts manual for your machine.

* Brand:

* Model:

* Serial:

* Part Number:

SEARCH

**Can't Find Part or
Manual? Request Help
by Manufacturer,
Model & Description**

Parts Order Form

Please fill in the following information to help us find the right part for your machine.

Manufacturer:	<input type="text"/>
Model:	<input type="text"/>
Description:	<input type="text"/>
Part Number:	<input type="text"/>
Quantity:	<input type="text"/>
Notes:	<input type="text"/>

Submit

Discount-Equipment.com is your online resource for quality parts & equipment.

Florida: **561-964-4949** Outside Florida TOLL FREE: **877-690-3101**

Need parts?

Click on this link: <http://www.discount-equipment.com/category/5443-parts/> and choose one of the options to help get the right parts and equipment you are looking for. Please have the machine model and serial number available in order to help us get you the correct parts. If you don't find the part on the website or on one of the online manuals, please fill out the request form and one of our experienced staff members will get back to you with a quote for the right part that your machine needs.

We sell worldwide for the brands: Genie, Terex, JLG, MultiQuip, Mikasa, Essick, Whiteman, Mayco, Toro Stone, Diamond Products, Generac Magnum, Airman, Haulotte, Barreto, Power Blanket, Nifty Lift, Atlas Copco, Chicago Pneumatic, Allmand, Miller Curber, Skyjack, Lull, Skytrak, Tsurumi, Husquvarna Target, Stow, Wacker, Sakai, Mi-T-M, Sullair, Basic, Dynapac, MBW, Weber, Bartell, Bennar Newman, Haulotte, Ditch Runner, Menegotti, Morrison, Contec, Buddy, Crown, Edco, Wyco, Bomag, Laymor, EZ Trench, Bil-Jax, F.S. Curtis, Gehl Pavers, Heli, Honda, ICS/PowerGrit, IHI, Partner, Imer, Clipper, MMD, Koshin, Rice, CH&E, General Equipment, Amida, Coleman, NAC, Gradall, Square Shooter, Kent, Stanley, Tamco, Toku, Hatz, Kohler, Robin, Wisconsin, Northrock, Oztec, Toker TK, Rol-Air, APT, Wylie, Ingersoll Rand / Doosan, Innovatech, Con X, Ammann, Mecalac, Makinex, Smith Surface Prep, Small Line, Wanco, Yanmar

2.10 Limit Switches

Index No.	Skyjack Part No.	Qty.	Description
A	192178	1	LIMIT SWITCH ASSEMBLY - MAIN/FLY BOOM
1	211446	1	• SWITCH ASSEMBLY, Limit - adjustable roller lever
2	103991	4	• WASHER, Flat (#8)
3	112249	2	• WASHER, Lock (#8)
4	152294	2	• SCREW, Round head machine (8-32 x 1.25")
5	103986	2	• NUT, Hex (#8-32)
B/C	192177	1	LIMIT SWITCH ASSEMBLY - RISER
6	211437	1	• SWITCH ASSEMBLY, Limit - roller lever, C
7	211443	1	• SWITCH ASSEMBLY, Limit - roller lever, B
8	103991	8	• WASHER, Flat (#8)
9	112249	4	• WASHER, Lock (#8)
10	162061	4	• SCREW, Round head machine (8-32 x 2.00")
11	103986	4	• NUT, Hex (#8-32)

2.11 Main Boom

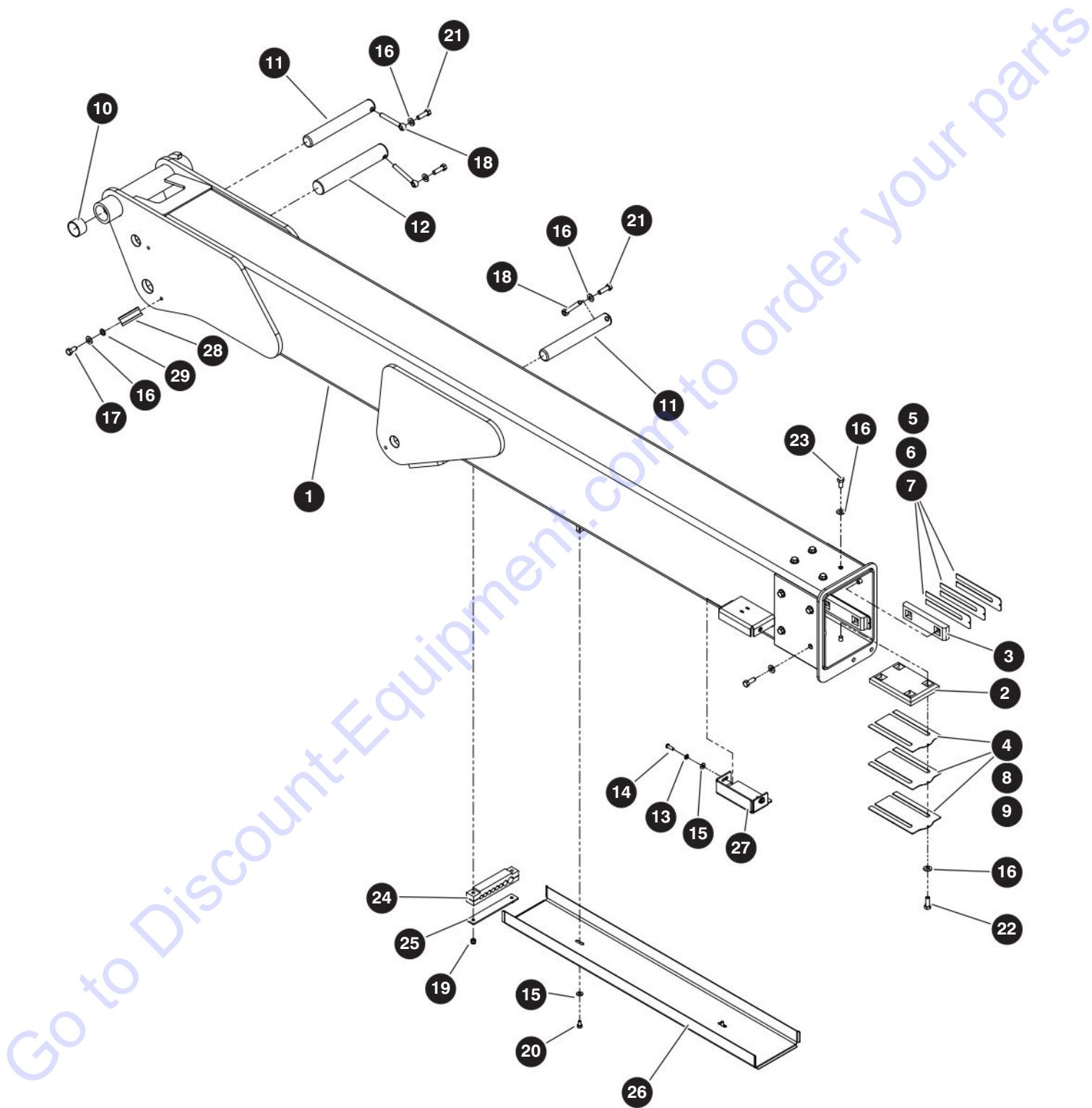

M192991AF

229034ADA

SJ30 AJE, SJ30 ARJE

2.11 Main Boom

Index No.	Skyjack Part No.	Qty.	Description
-	192991	1	MAIN BOOM
1	230272	1	• WELDMENT, Main boom
2	192978	2	• PAD, Wear (4.00" x 5.50" x 0.6875")
3	192493	4	• PAD, Wear (1.50" x 6.00" x 0.6875")
4	192966	2	• SHIM, Top (0.020")
5	192977	4	• SHIM, 25 gauge
6	192497	4	• SHIM, Side(0.06")
7	192498	4	• SHIM, 20 gauge (1.50" x 6.25")
8	192499	2	• SHIM, Top (0.06")
9	192500	2	• SHIM, Top (0.036")
10	100904	4	• BEARING, Plain (1.5" ID x 1.625" OD x 1.00" FG)
11	148844	2	• PIN, Boom (1.25" dia x 9.00" lg)
12	192465	1	• PIN, Boom (1.50" dia x 9.00" lg)
13	104000	2	• WASHER, Lock (0.25")
14	139168	2	• BOLT, Button head cap screw (0.25"-20 x 0.75")
15	103995	4	• WASHER, Flat (0.25")
16	103472	22	• WASHER, Flat (0.375")
17	101632	1	• BOLT, Hex head (0.375"-16 x 0.75" gr 5)
18	146897	3	• PIN, Keeper (0.375")
19	115649	2	• NUT, Lock (0.25"-20 gr 5 nylon)
20	103855	2	• BOLT, Hex head (0.25"-20 x 0.50" gr 5)
21	101297	3	• BOLT, Hex head (0.375"-16 x 1.25" ge 5)
22	207298	12	• BOLT, Hex head (0.375"-16 x 1.00" gr 8)
23	158488	4	• BOLT, Hex head (0.375"-16 x 0.75" gr 8)
24	192908	1	• CLAMP, Hose - main
25	192909	1	• PLATE, Clamp - main
26	192753	1	• COVER, Main boom
27	207285	1	• COVER, Limit Switch
28	171177	1	• CLAMP, Loop (2")
29	103999	1	• WASHER, Lock (0.375")

2.12 Fly Boom

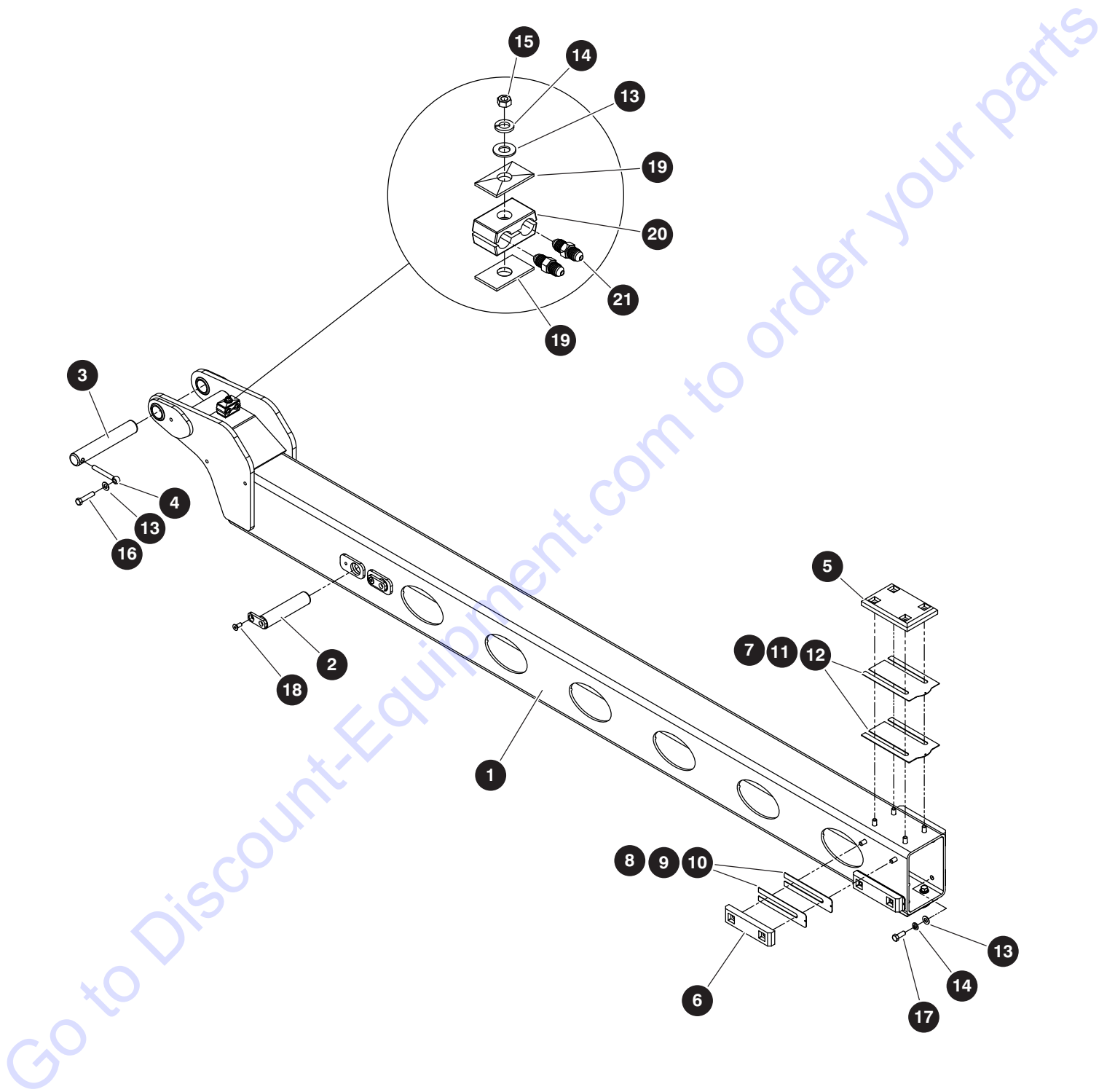

M192897AC

229034ADA

56

SJ30 AJE, SJ30 ARJE

SKYJACK

2.12 Fly Boom

Index No.	Skyjack Part No.	Qty.	Description
-	192897	1	FLY BOOM
1	230275	1	• WELDMENT, Fly boom
2	148839	2	• PIN, Boom (1.25" dia x 5.688" lg)
3	165197	1	• PIN, Boom (1.25" dia x 7.75" lg)
4	146897	1	• PIN, Keeper (0.375")
5	192978	2	• PAD, Wear (4.00" x 5.50" x 0.6875")
6	192493	4	• PAD, Wear (1.50" x 6.00" x 0.6875")
7	192966	2	• SHIM, Top (0.02")
8	192977	4	• SHIM, 25 gauge
9	192497	4	• SHIM, Side(0.06")
10	192498	4	• SHIM, 20 gauge (1.50" x 6.25")
11	192499	2	• SHIM, Top (0.06")
12	192500	2	• SHIM, Top (0.036")
13	103472	18	• WASHER, Flat (0.375")
14	103999	17	• WASHER, Lock (0.375")
15	103980	1	• NUT, Hex head (0.25"-20 gr 8)
16	101632	1	• BOLT, Hex head (0.375"-16 x 0.75")
17	125471	16	• BOLT, Hex head (0.375"-16 x 1.00")
18	704642	2	• SCREW, Flat head cap (0.312"-18 x 0.75" gr5)
19	923668	2	• PLATE, Cover
20	933048	1	• CLAMP
21	933377	2	• FITTING, Flare tube straight (04JICM-04JICM)

2.13 Cable Track

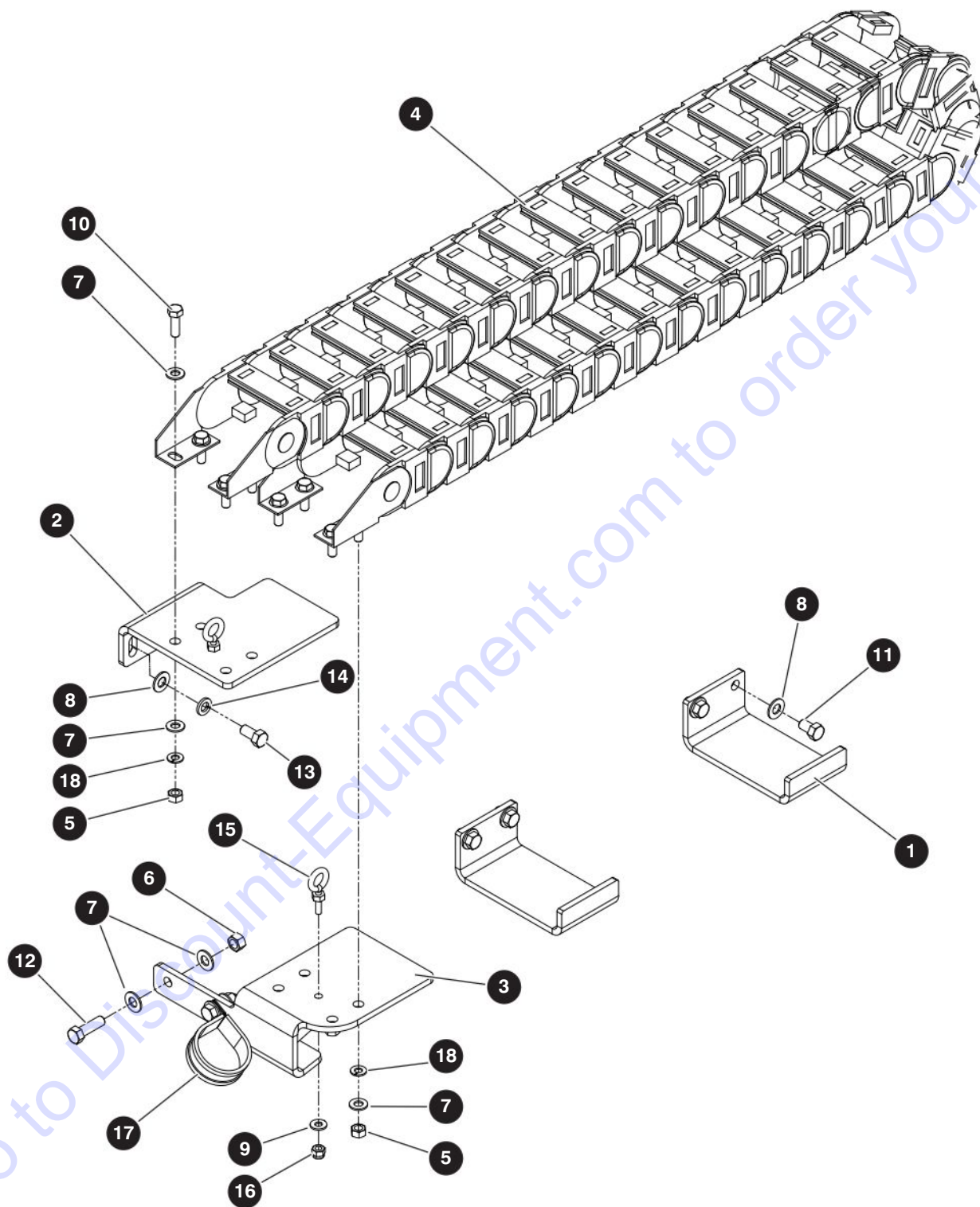

M192922AD

229034ADA

SJ30 AJE, SJ30 ARJE

2.13 Cable Track

Index No.	Skyjack Part No.	Qty.	Description
-	192992	1	CABLE TRACK
1	192813	2	• BRACKET, E-chain
2	192848	1	• BRACKET, E-chain upper
3	192863	1	• BRACKET, E-chain lower
4	192988	1	• E-CHAIN
	209533	1	• • MOUNTING BRACKET SET
	209531	33	• • LINK, Right side (outer)
	209532	33	• • LINK, Left side (inner)
	209530	32	• • CROSSBAR
5	100397	8	• NUT, Hex (0.312"-18 gr 5)
6	103978	2	• NUT, Hex (0.375"-16 gr 5)
7	103996	16	• WASHER, Flat (0.312")
8	103472	10	• WASHER, Flat (0.375")
9	103995	2	• WASHER, Flat (0.25")
10	103864	8	• BOLT, Hex head (0.312"-18 x 1.00")
11	138464	4	• BOLT, Hex head (0.375"-16 x 0.625")
12	101297	2	• BOLT, Hex head (0.375"-16 x 1.25")
13	101632	2	• BOLT, Hex head (0.375"-16 x 0.75")
14	103999	4	• WASHER, Lock (0.375")
15	162168	2	• BOLT, Eye (0.25"-20 x 1.00")
16	115649	2	• NUT, Lock (0.25"-20 gr 5 nylon)
17	171177	1	• CLAMP, Loop - vinyl coated (2" dia)
18	103404	8	• WASHER, Lock (0.312")

2.14 Rotating Jib Manifold

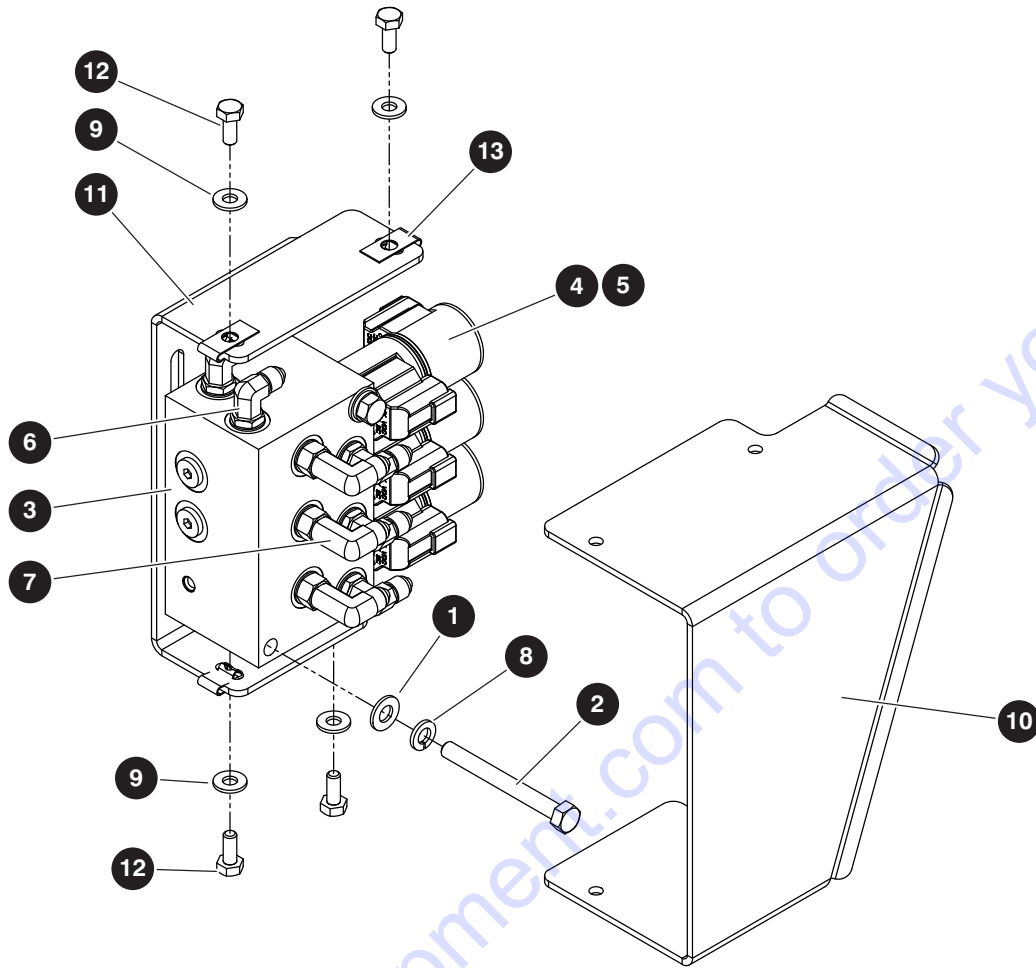

M192977AC

Index No.	Skyjack Part No.	Qty.	Description
-	192997	1	ROTATING JIB MANIFOLD
1	103996	2	• WASHER, Flat (0.312" SAE)
2	103867	2	• BOLT, Hex head (0.312"-18 x 3.00" gr 5)
-	192055	1	• MANIFOLD, Platform
3	209022	1	• • BLOCK, Manifold
4	166036	3	• • VALVE
5	159821	6	• • COIL
6	125883	5	• • FITTING, 90° elbow (04MJ-04MB)
7	147552	3	• • FITTING, 90° elbow long (04JICM-04ORBM)
8	103404	2	• WASHER, Lock (0.312")
9	103955	4	• WASHER, Flat (0.25" SAE)
10	192872	1	• COVER, Jib manifold
11	192873	1	• BRACKET, Platform manifold
12	103892	4	• BOLT, Hex head (0.25"-20 x 0.625" gr 5)
13	163459	4	• NUT, Speed clip (0.25"-20 x 0.56")

2.15 Non-Rotating Jib Manifold

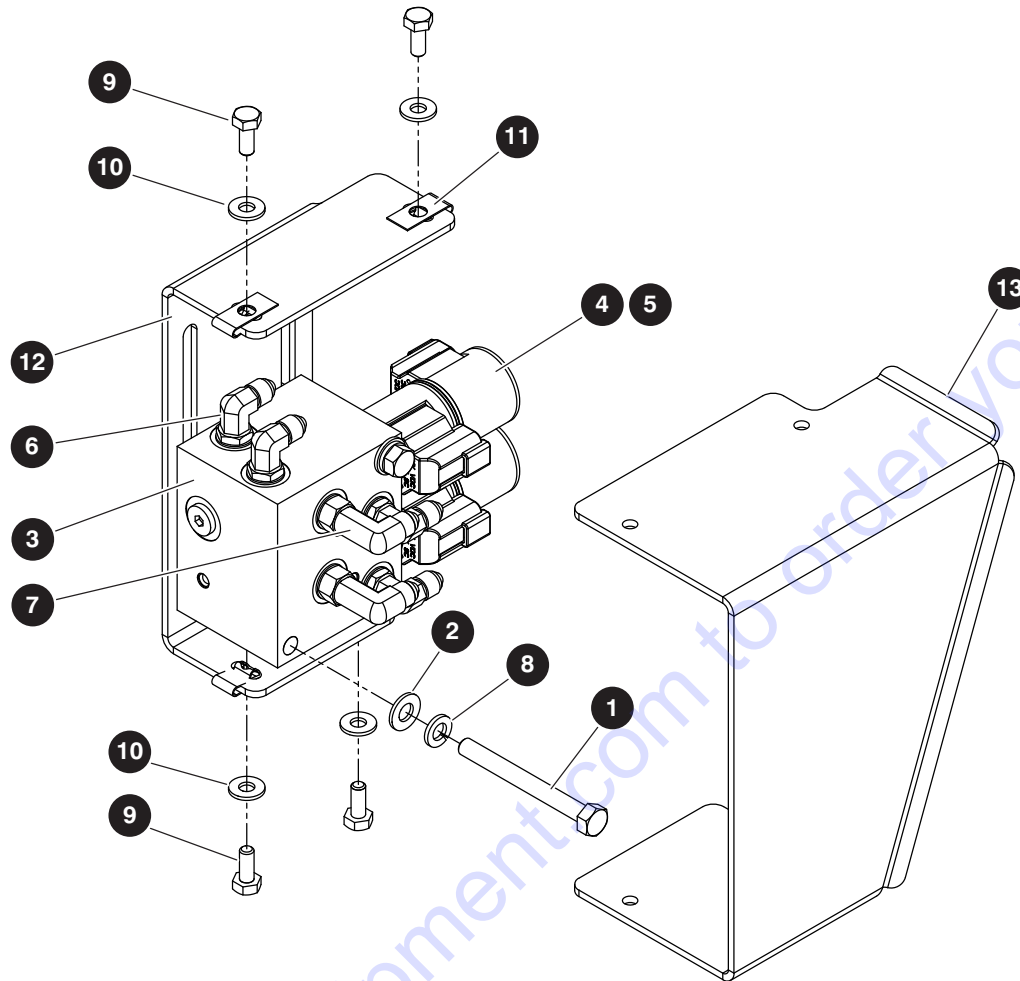

M192998AC

Index No.	Skyjack Part No.	Qty.	Description
-	192998	1	NON-ROTATING JIB MANIFOLD
1	103867	2	• BOLT, Hex head (0.312"-18 x 3.00" gr 5)
2	103996	2	• WASHER, Flat (0.312" SAE)
-	192162	1	• MANIFOLD, Platform - non rotating
3	209027	1	• • BLOCK, Manifold
4	166036	2	• • VALVE
5	159821	4	• • COIL
6	125883	4	• • FITTING, 90° elbow (04MJ-04MB)
7	147552	2	• • FITTING, 90° elbow long (04JICM-04ORBM)
8	103404	2	• WASHER, Lock (0.312")
9	103892	4	• BOLT, Hex head (0.25"-20 x 0.625" gr 5)
10	103995	4	• WASHER, Flat (0.25" SAE)
11	163459	4	• NUT, Speed clip (0.25"-20 x 0.56")
12	192873	1	• BRACKET, Platform manifold
13	192872	1	• COVER, Jib manifold

2.16 Jib Arm Assembly

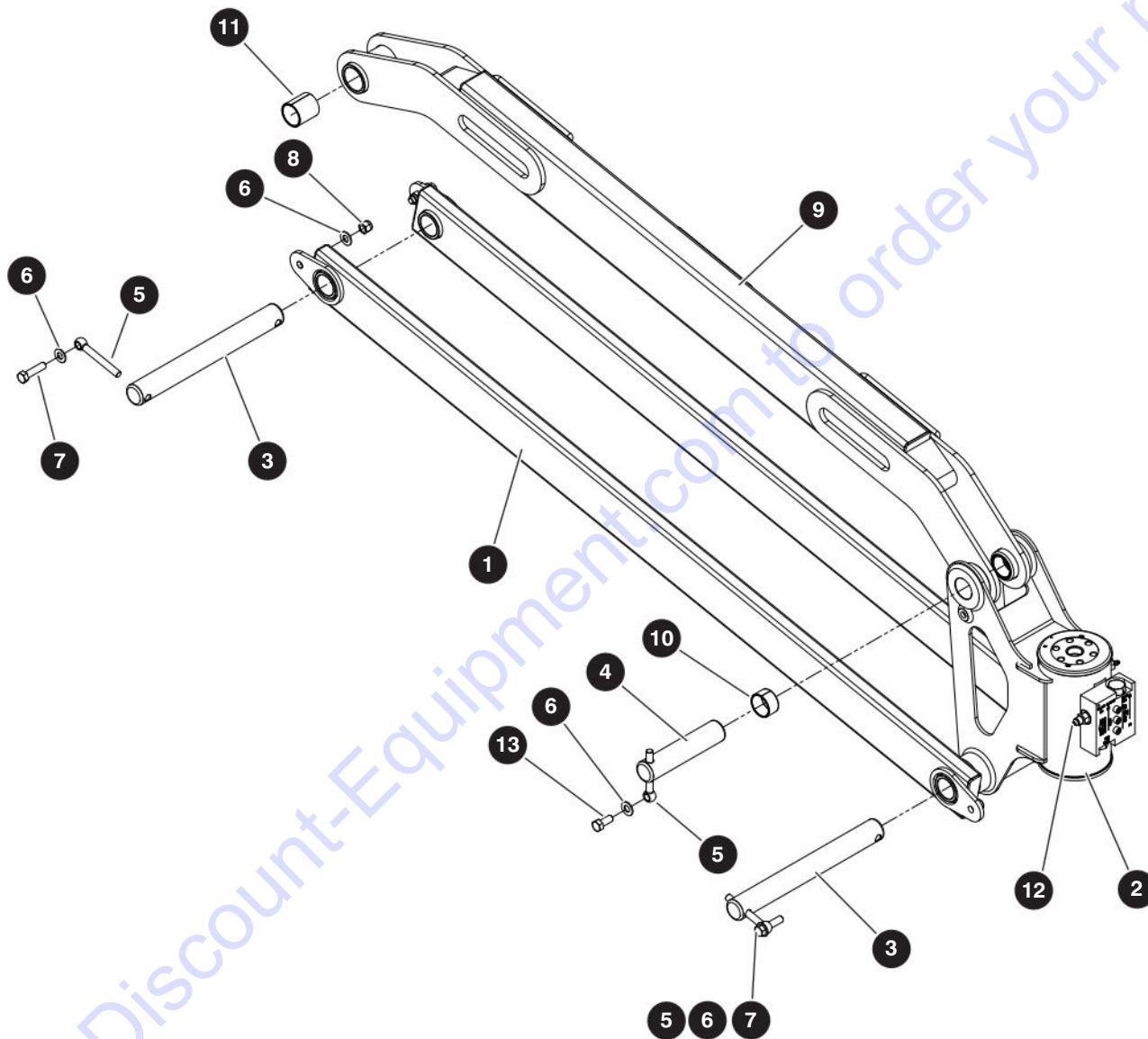

M192994AF

229034ADA

62

SJ30 AJE, SJ30 ARJE

SKYJACK

2.16 Jib Arm Assembly

Index No.	Skyjack Part No.	Qty.	Description
-	192994	1	JIB ARM ASSEMBLY
1	226358	2	• ARM, Lower
2	192208	1	• ACTUATOR, Rotary platform
	141399	1	• • VALVE, Counterbalance
	209194	1	• • SEAL KIT
3	192547	2	• PIN, Mounting - bracket
4	154235	1	• PIN, Mounting - cylinder
5	146897	5	• PIN, Keeper (0.375")
6	103472	9	• WASHER, Flat (0.375" SAE)
7	103870	4	• BOLT, Hex head (0.375"-16 x 1.50" gr 5)
8	104606	4	• NUT, Lock (0.375"-16 gr 5 nylon)
9	226355	1	• ARM, Upper
10	101523	2	• BUSHING, Fiberglide (1.25" dia x 0.75")
11	125262	2	• BUSHING, Fiberglide (1.25" dia x 1.50")
12	126128	2	• FITTING, Straight (04JICM-04ORBM)
13	103473	1	• BOLT, Hex head (.375"-16 x 1.00" gr 5)

2.17 Rotating Jib

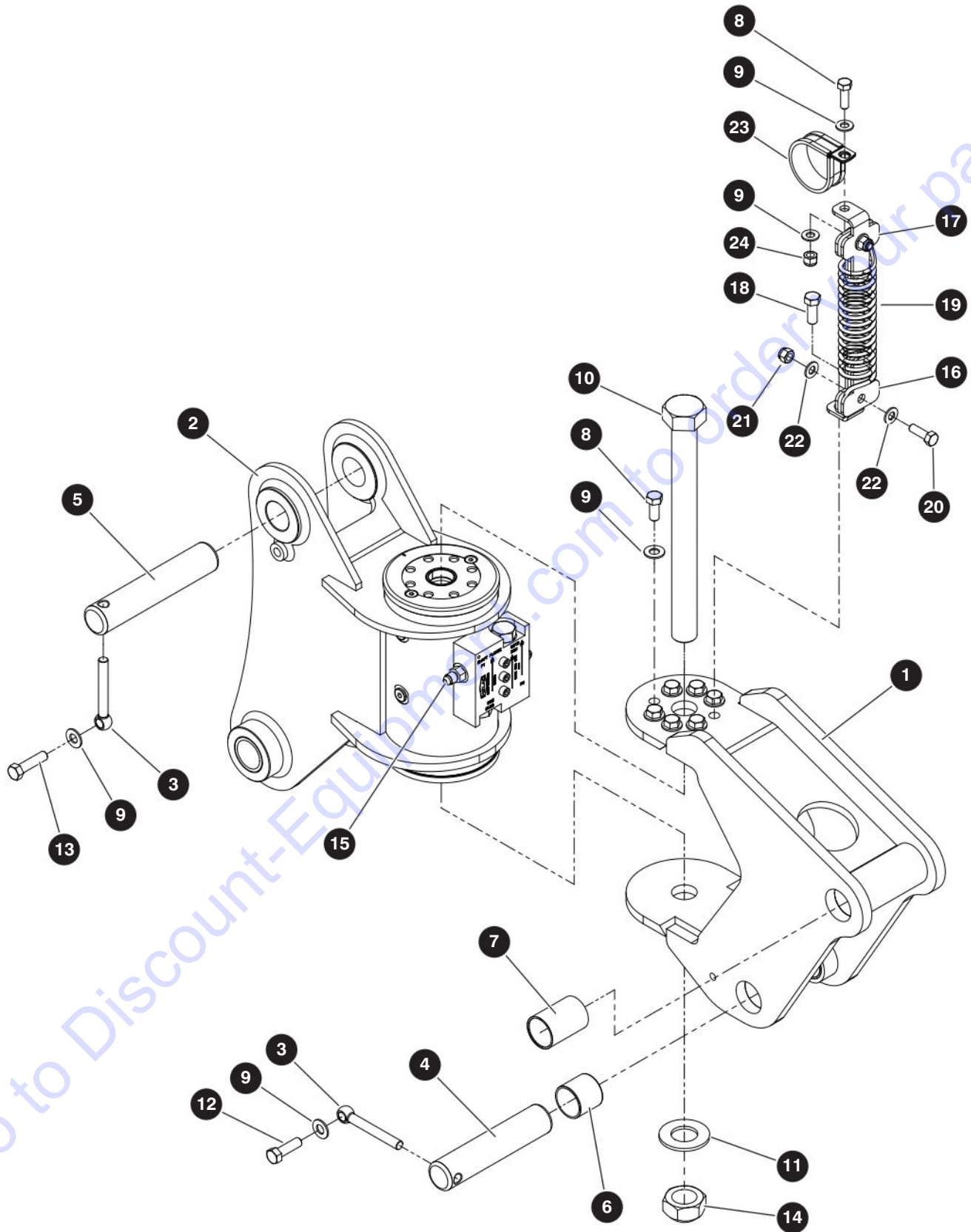

M192993AD

229034ADA

SJ30 AJE, SJ30 ARJE

2.17 Rotating Jib

Index No.	Skyjack Part No.	Qty.	Description
-	192993	1	ROTATING JIB
1	230264	1	• BRACKET
2	192207	1	• ACTUATOR, Rotary - jib
	141399	2	• • VALVE, Counterbalance
	144709	1	• • SEAL KIT
3	146897	2	• PIN, Keeper (0.375")
4	154235	1	• PIN, Mounting
5	192549	1	• PIN, Mounting
6	100071	2	• BUSHING, Fiberglide
7	125230	2	• BUSHING, Fiberglide (0.25" dia x 2.00")
8	125741	8	• BOLT, Hex head (0.375"-16 x 0.875" gr 5)
9	103472	11	• WASHER, Flat (0.375" SAE)
10	138696	1	• BOLT, Hex head (1.0"-8 x 10.5" gr 8)
11	102646	1	• WASHER, Flat (1.00" SAE)
12	101297	1	• BOLT, Hex head (0.375"-16 x 1.25" gr 5)
13	103870	1	• BOLT, Hex head (0.375"-16 x 1.50" gr 5)
14	138559	1	• NUT, Torque lock (1.00"-8 gr 8 nylon)
15	126128	2	• FITTING, Straight (04JICM-04ORBM)
16	207296	2	• CLAMP, Spring retainer
17	207297	2	• CLAMP, Spring retaininer angled
18	207298	1	• BOLT, Hex head (0.375"-16 x 1.00" gr 8)
19	207292	1	• SPRING (1.5" OD x 0.177" dia x 5.5" lg)
20	103864	2	• BOLT, Hex head (0.312"-18 x 1.00" gr 5)
21	103984	2	• NUT, Lock (0.313"-18 gr 5 nylon)
22	103996	4	• WASHER, Flat (0.312" SAE)
23	171177	1	• CLAMP, Loop - vinyl coated (2" dia)
24	104606	1	• NUT, Lock (0.375"-16 gr 5 nylon)

2.18 Non-Rotating Jib

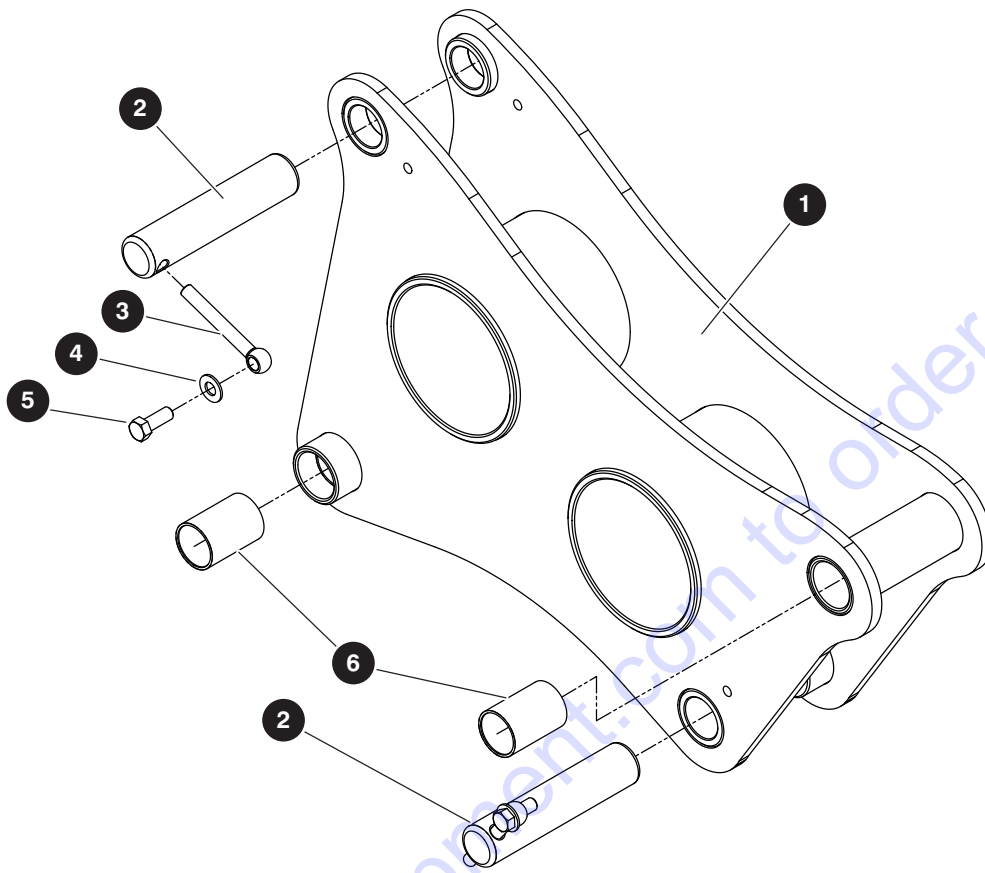

M192575AD

Index No.	Skyjack Part No.	Qty.	Description
-	192575	1	NON-ROTATING JIB
1	230270	1	• Bracket
2	154235	2	• PIN, Mounting
3	146897	2	• PIN, Keeper (0.375")
4	103472	2	• WASHER, Flat (0.375" SAE)
5	103473	2	• BOLT, Hex head (0.375"-16 x 1.00" gr 5)
6	125230	4	• BUSHING, Fiberglide (1.25" dia x 2.00")

Section 3 – Cylinders

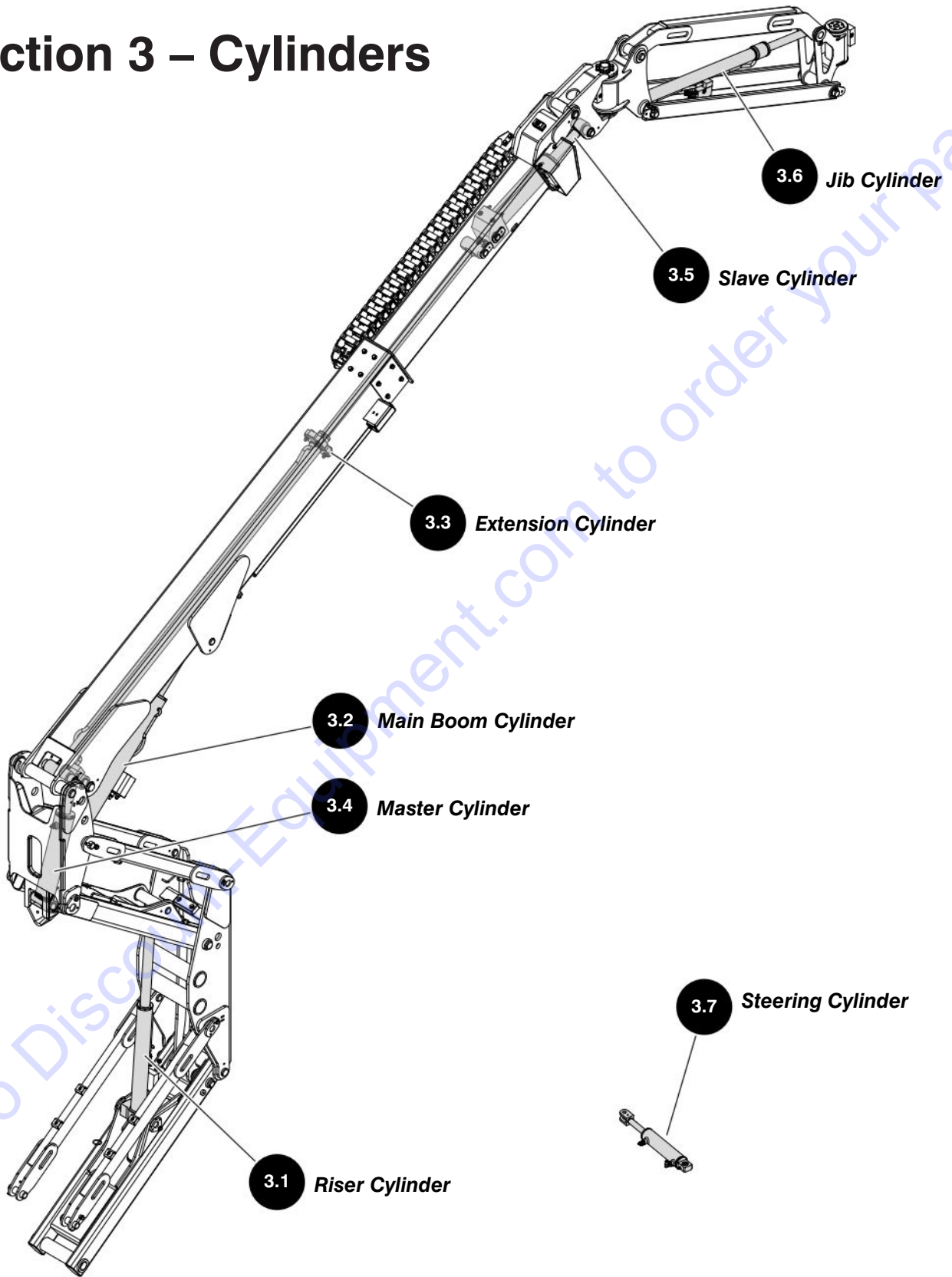

3.1 Riser Cylinder

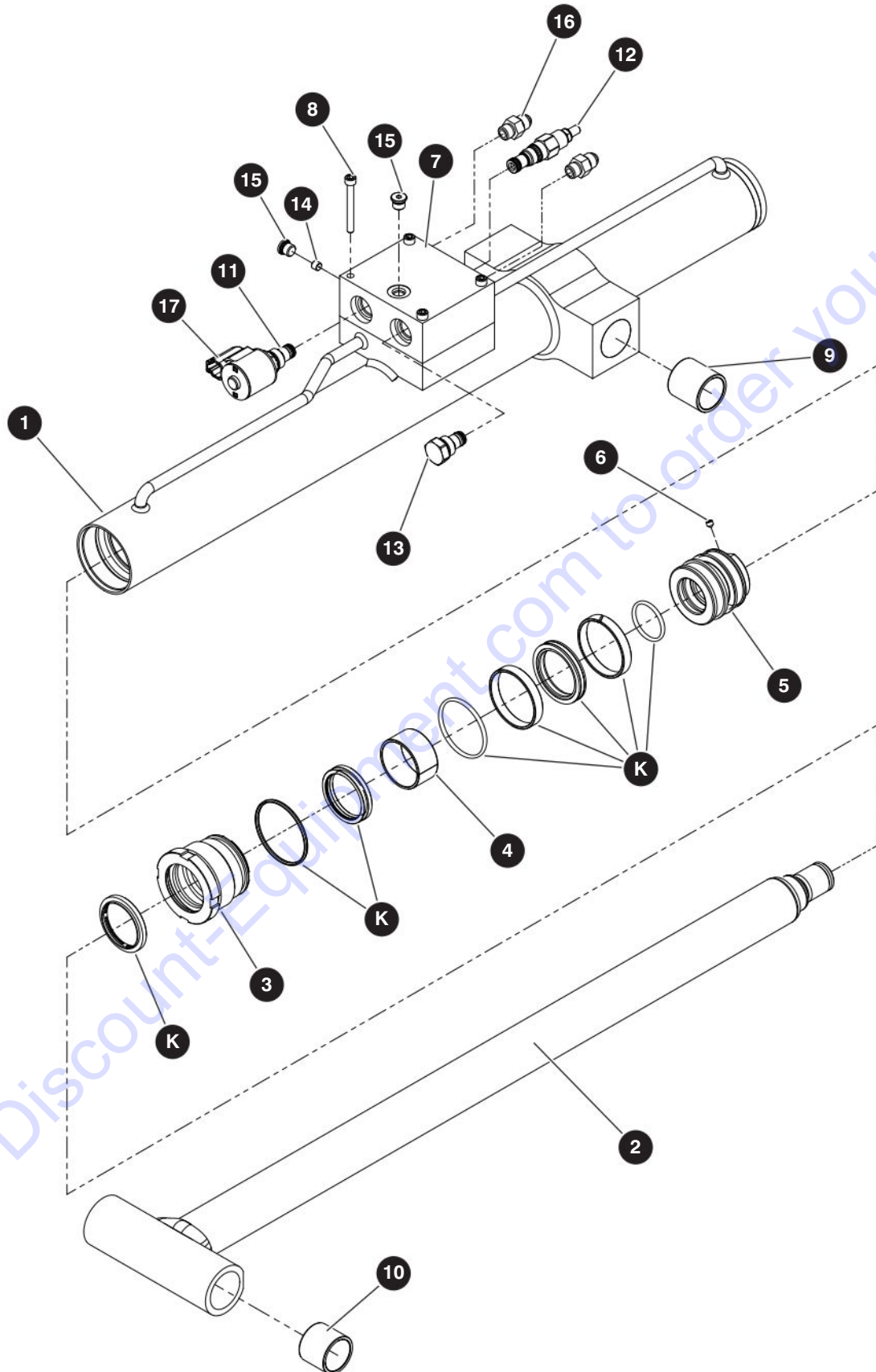

M192130AD

229034ADA

SJ30 AJE, SJ30 ARJE

3.1 Riser Cylinder

Index No.	Skyjack Part No.	Qty.	Description
-	192130	1	RISER CYLINDER
-	207328	1	• CYLINDER, Riser
1	210083	1	• • TUBE
2	210084	1	• • ROD
3	209104	1	• • GLAND
4	209112	1	• • BEARING, Dry
5	210085	1	• • PISTON
6	209087	1	• • SCREW, Set (M6 x 1 x 6L)
7	209106	1	• • BLOCK, Manifold
8	209107	4	• • BOLT, Hex socket (M6 x 1 x 55L)
9	170710	2	• • BEARING, MRP (1.25" dia x 1.25" lg)
10	209108	2	• • BEARING, MRP
11	209109	1	• • VALVE, Solenoid
12	209110	1	• • VALVE, Relief
13	199471	1	• • VALVE, Check
14	209114	1	• • PLUG, Orifice (0.040")
15	209091	3	• • FITTING, Plug hex socket (7/16-20 UNF)
16	103069	2	• FITTING, Straight (06SAE-06JIC)
17	159821	1	• COIL, Solenoid (12V DC)
K	209115	1	SEAL KIT, Riser cylinder
T	218812	1	CHOCK, Riser cylinder (not shown)

3.2 Main Boom Cylinder

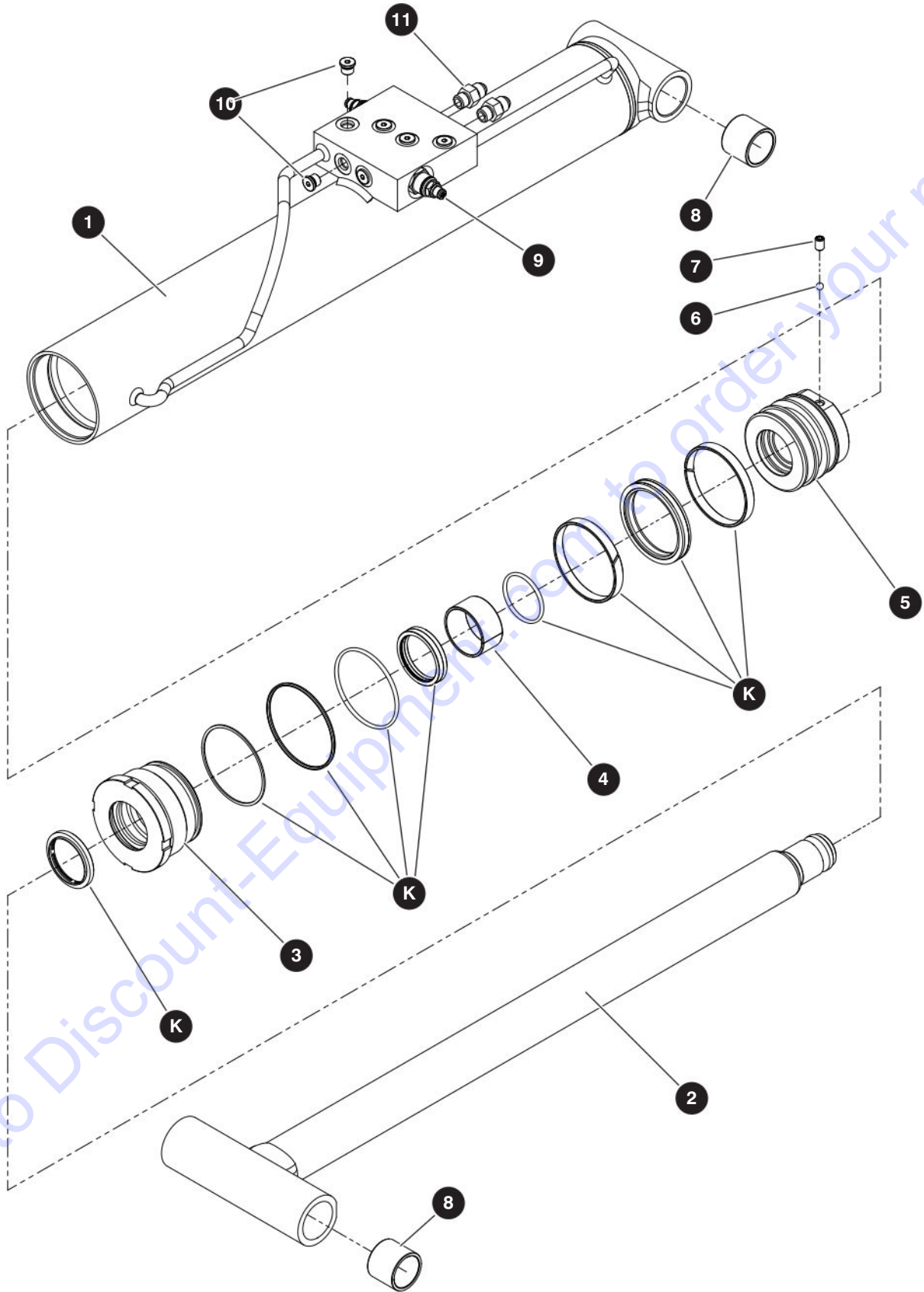

M192131AB

229034ADA

70

SJ30 AJE, SJ30 ARJE

SKYJACK

3.2 Main Boom Cylinder

Index No.	Skyjack Part No.	Qty.	Description
-	192131	1	MAIN BOOM CYLINDER
-	192073	1	• CYLINDER, Main
1	209116	1	• • TUBE
2	209117	1	• • ROD
3	209118	1	• • GLAND
4	209112	1	• • BEARING, Dry
5	209120	1	• • PISTON
6	209121	1	• • BALL, Steel (6.35 mm)
7	209122	1	• • SCREW, Set (M8 x 1.25 x 12)
8	170710	4	• • BEARING, MRP
9	209153	2	• • VALVE, Counterbalance
10	209091	6	• • FITTING, Plug hex socket (7/16-20 UNF)
11	103069	2	• FITTING, Straight (06SAE-06JIC)g
K	209126	1	SEAL KIT, Main Boom Cylinder

3.3 Extension Cylinder

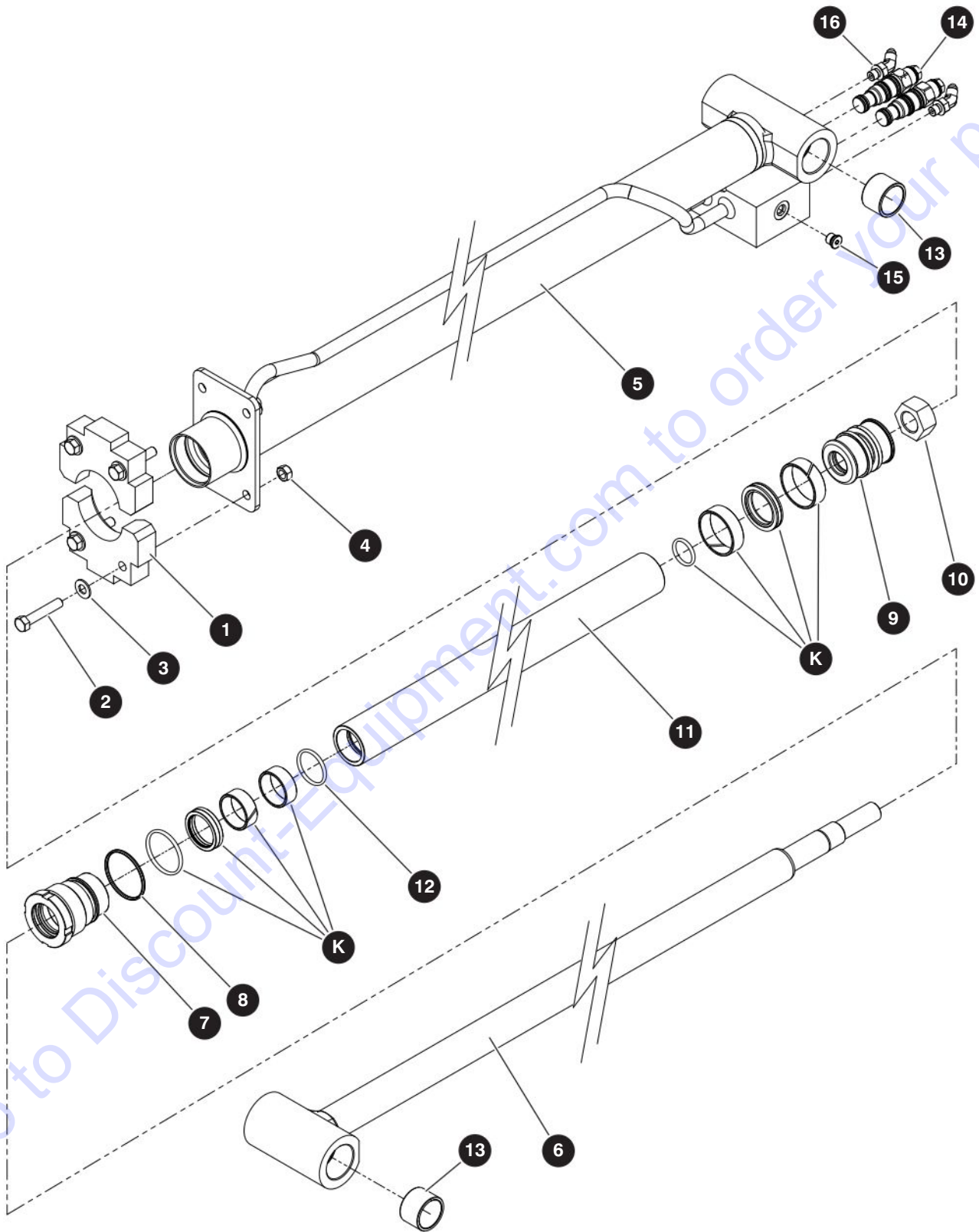

M192678AB

229034ADA

SJ30 AJE, SJ30 ARJE

3.3 Extension Cylinder

Index No.	Skyjack Part No.	Qty.	Description
-	192678	1	EXTENSION CYLINDER
1	192919	2	• PAD, Wear
2	103596	4	• BOLT, Hex head (0.375"-16 x 2.00" gr 5)
3	103472	4	• WASHER, Flat (0.375")
4	144238	4	• NUT, Torque lock (0.375"-16 gr C)
-	192074	1	• CYLINDER, Extension
5	209127	1	• • TUBE
6	209128	1	• • ROD
7	209129	1	• • GLAND
8	209113	1	• • O-RING
9	209130	1	• • PISTON
10	209133	1	• • NUT, Hex (M24 x 2, type 1)
11	209132	1	• • SPACER
12	209203	1	• • O-RING
13	209131	4	• • BEARING, MRP (31.75 x 38.1 x 25.4L)
14	141453	2	• • VALVE, Counterbalance
15	209091	6	• • FITTING, Plug hex socket (7/16-20 UNF)
16	131716	2	• FITTING, 45° elbow (04JICM-04ORBM)
K	209205	1	SEAL KIT, Extension Cylinder

3.4 Master Cylinder

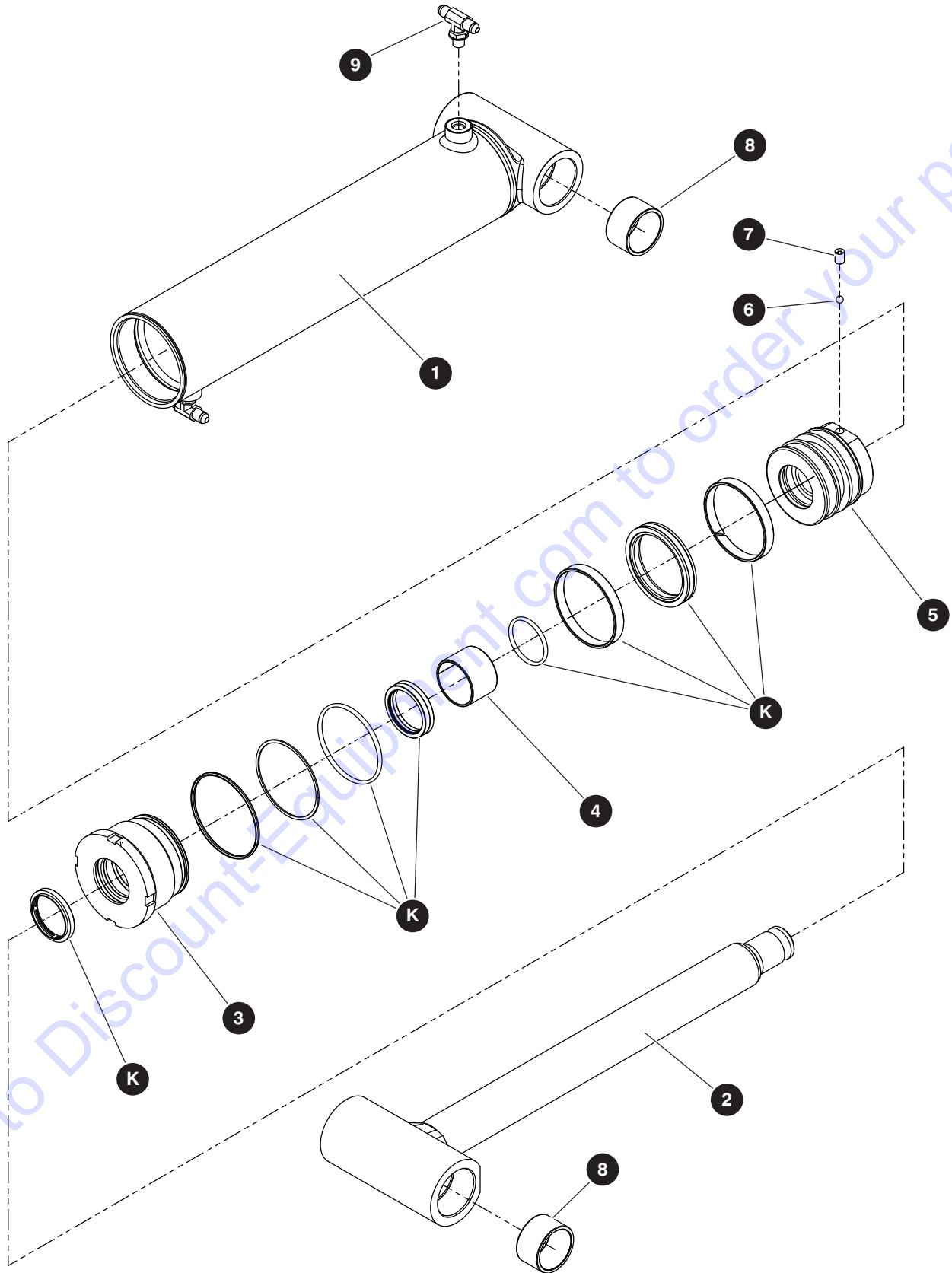

M192132AB

229034ADA

SJ30 AJE, SJ30 ARJE

3.4 Master Cylinder

Index No.	Skyjack Part No.	Qty.	Description
-	192132	1	MASTER CYLINDER
-	192076	1	• CYLINDER, Master
1	209144	1	• • TUBE
2	209145	1	• • ROD
3	209146	1	• • GLAND
4	209148	1	• • BEARING, Dry
5	209147	1	• • PISTON
6	209190	1	• • BALL, Steel (6 mm)
7	209191	1	• • SCREW, Set (M8 x 1.25 x 12L)
8	209148	4	• • BEARING, MRP (31.8 x 44.45 x 25.4)
9	126128	2	• FITTING, Straight (04SAE-04JIC)
K	209192	1	SEAL KIT, Master cylinder
T	207288	2	TOOL, Pin weldment (not shown) This tool (x 2) is needed when replacing the master cylinder

3.5 Slave Cylinder

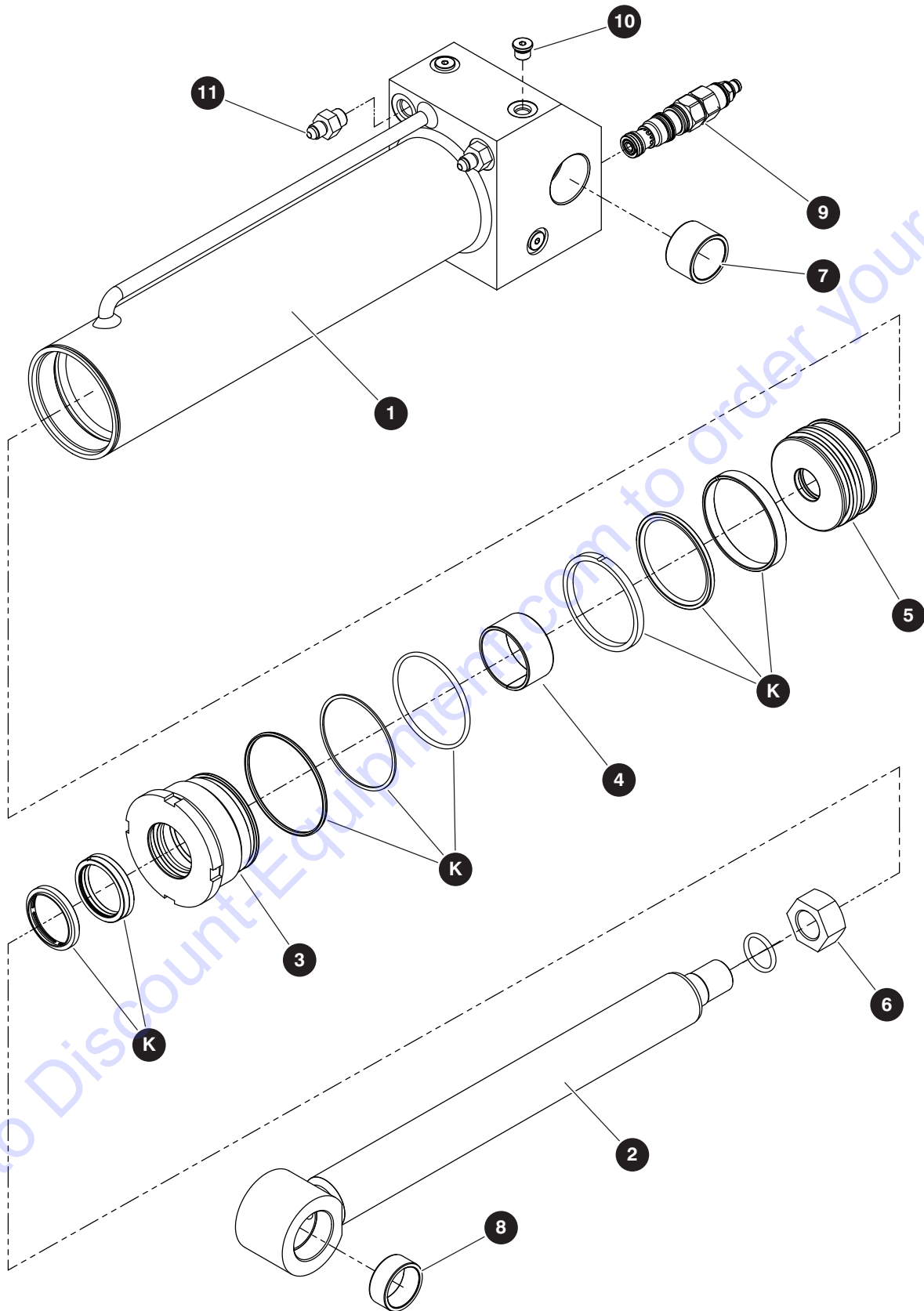

M192133AB

229034ADA

SJ30 AJE, SJ30 ARJE

3.5 Slave Cylinder

Index No.	Skyjack Part No.	Qty.	Description
-	192133	1	SLAVE CYLINDER
-	192077	1	• CYLINDER, Slave
1	209149	1	• • TUBE
2	209150	1	• • ROD
3	209151	1	• • GLAND
4	209112	1	• • BEARING, Dry
5	209152	1	• • PISTON
6	209133	1	• • NUT, Hex (M24 x 2, type 1)
7	209131	2	• • BEARING, MRP (31.75 x 38.1 x 25.4L)
8	209154	2	• • BEARING, MRP (31.75 x 38.1 x 15.875L)
9	209153	2	• • VALVE, Counterbalance
10	209091	6	• • FITTING, Plug hex socket (7/16-20 UNF)
11	701956	2	• FITTING, Straight (06SAE-04JIC)
K	209193	1	SEAL KIT, Slave cylinder

3.6 Jib Cylinder

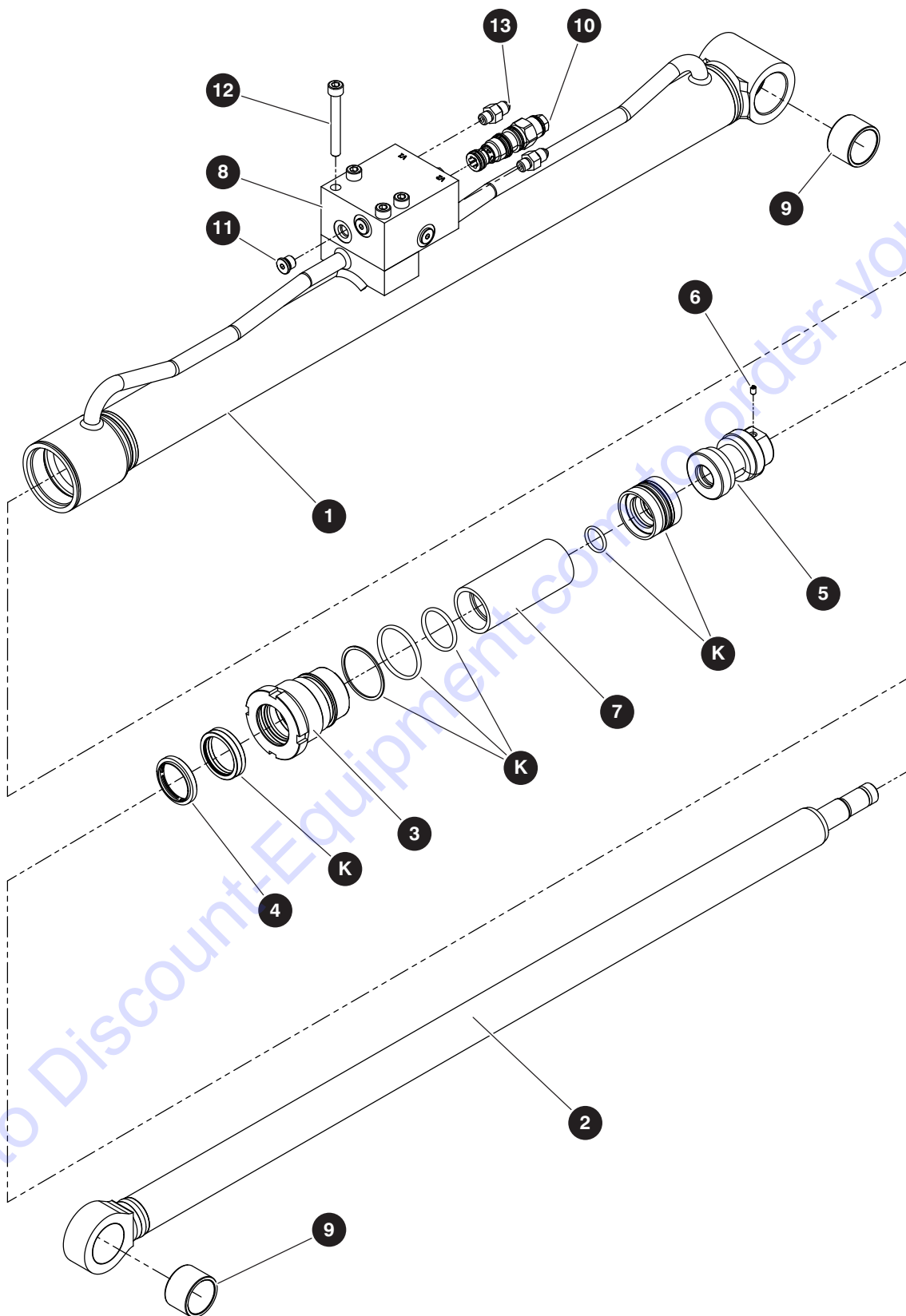

M192677AC

229034ADA

SJ30 AJE, SJ30 ARJE

3.6 Jib Cylinder

Index No.	Skyjack Part No.	Qty.	Description
-	192677	1	JIB CYLINDER
-	207339	1	• CYLINDER, Jib
1	209140	1	• • TUBE
2	209141	1	• • ROD
3	209135	1	• • GLAND
4	209207	1	• • SEAL, Dust wiper
5	209142	1	• • PISTON
6	209087	1	• • SCREW, Set (M6 x 1.0 x 6)
7	209143	1	• • SPACER
8	209134	1	• • BLOCK, Manifold
9	209131	3	• • BEARING, MRP (31.75 x 38.1 x 25.4L)
10	149372	2	• • VALVE, COUNTERbalance (CBBB-LHN 3000)
11	209091	6	• • FITTING, Plug hex socket (7/16-20 UNF)
12	209136	4	• • BOLT, Hex socket (M8 x 1.25 x 65L)
13	126128	2	• FITTING, Straight (04SAE-04JIC)
K	209208	1	SEAL KIT, Jib cylinder

3.7 Steering Cylinder

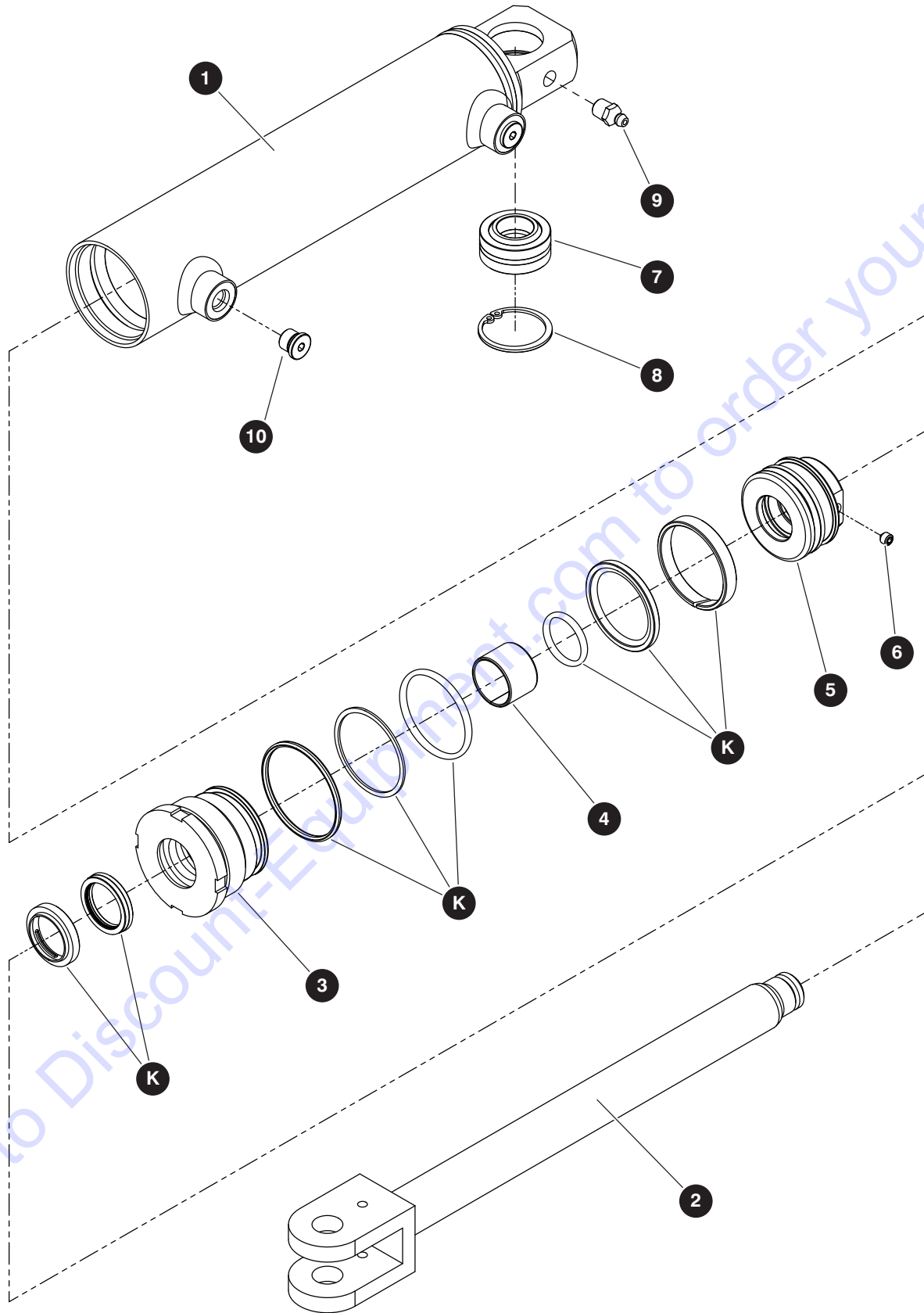

M192078AC

229034ADA

3.7 Steering Cylinder

Index No.	Skyjack Part No.	Qty.	Description
-	192078	1	STEERING CYLINDER
1	209082	1	• TUBE
2	209083	1	• ROD
3	209084	1	• GLAND
4	209086	1	• BEARING, DRY
5	209085	1	• PISTON
6	209087	1	• SCREW, SET (M6 X 1 X 6L)
7	209088	1	• BEARING, Spherical
8	209089	1	• RING, Snap
9	100581	1	• FITTING, Grease (1/8 NPT 45° elbow)
10	209091	2	• FITTING, Plug hex socket (7/16-20 UNF)
K	209092		SEAL KIT, Steering cylinder

Section 4 – Turret

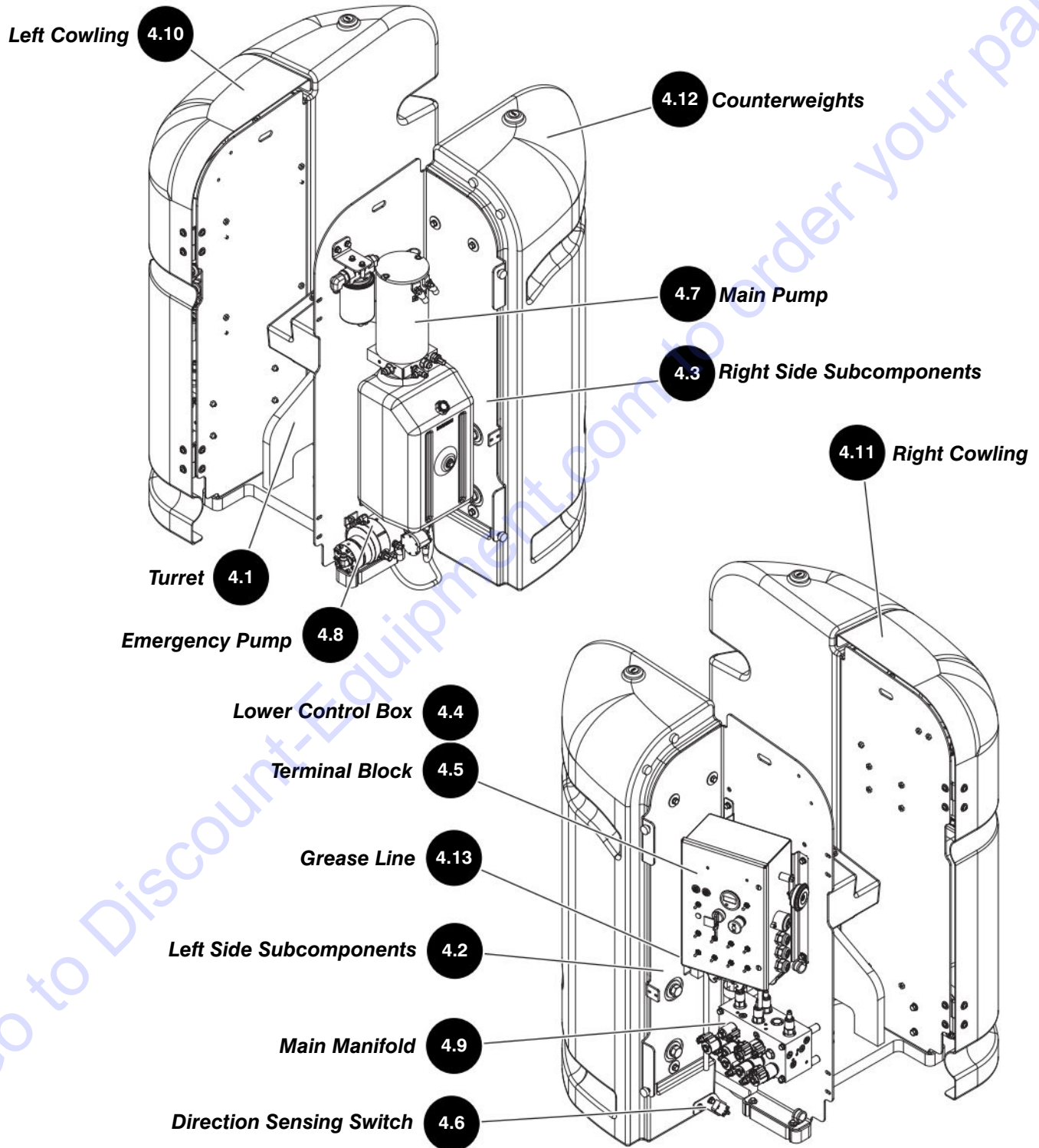

4.1 Turret

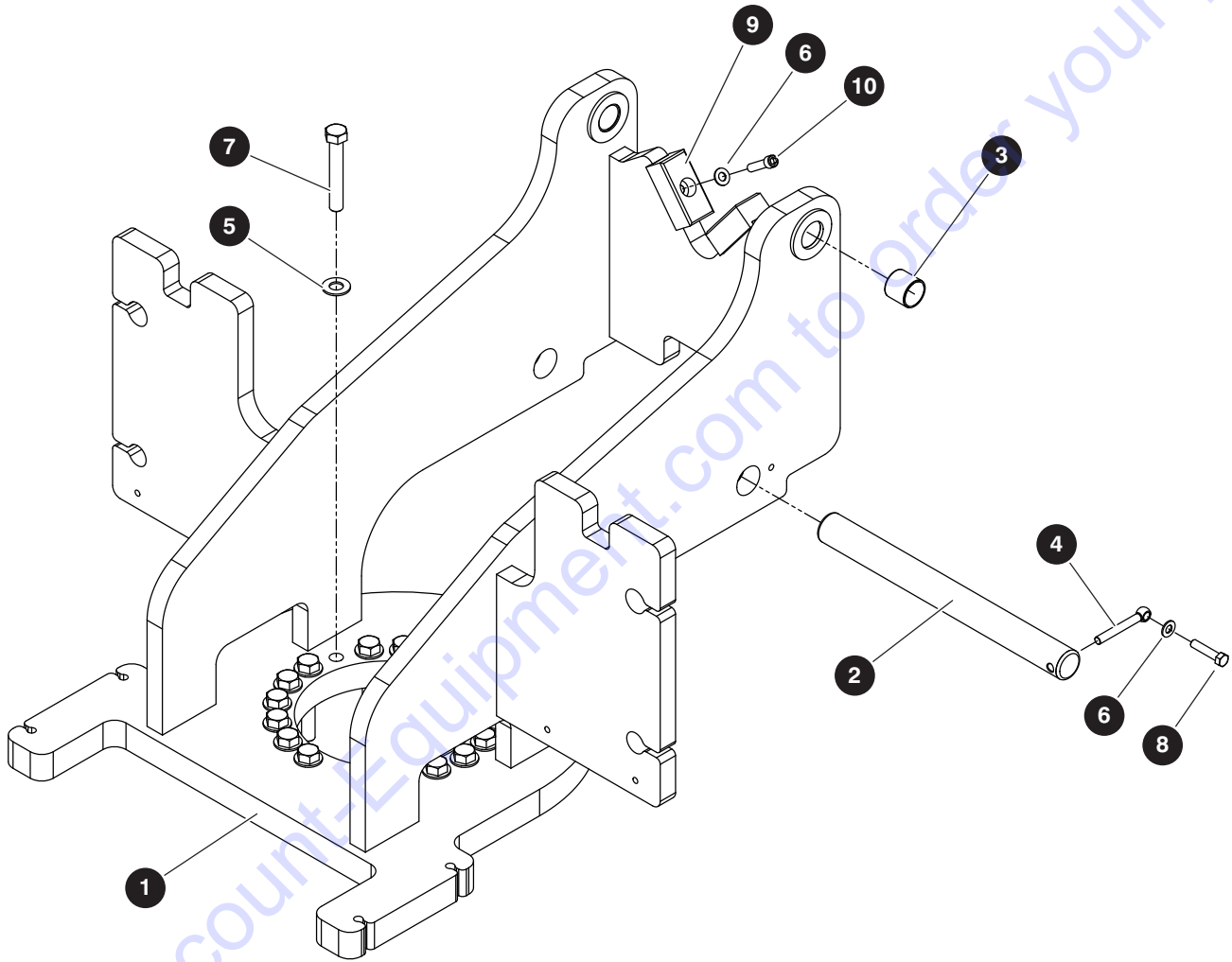

M192211AD

229034ADA

SJ30 AJE, SJ30 ARJE

4.1 Turret

Index No.	Skyjack Part No.	Qty.	Description
-	192211	1	TURRET ASSEMBLY
1	192262	1	• WELDMENT, Turret
2	192459	1	• PIN, 1.50" x 1.75" lg
3	100071	2	• BUSHING, Fiberglide
4	146897	1	• PIN, Keeper (0.375")
5	700782	19	• WASHER, Flat (0.625" hard)
6	103472	3	• WASHER, Flat (0.375" SAE)
7	192219	19	• BOLT, Hex head (0.625"-11 x 4.00" gr 8)
8	103871	1	• BOLT, Hex head *0.375"-16 x 1.75" gr 5)
9	192779	2	• PAD, Riser rest
10	192999	2	• SCREW, Socket head cap (0.375"-16 x 1.25")

4.2 Left Side Subcomponents

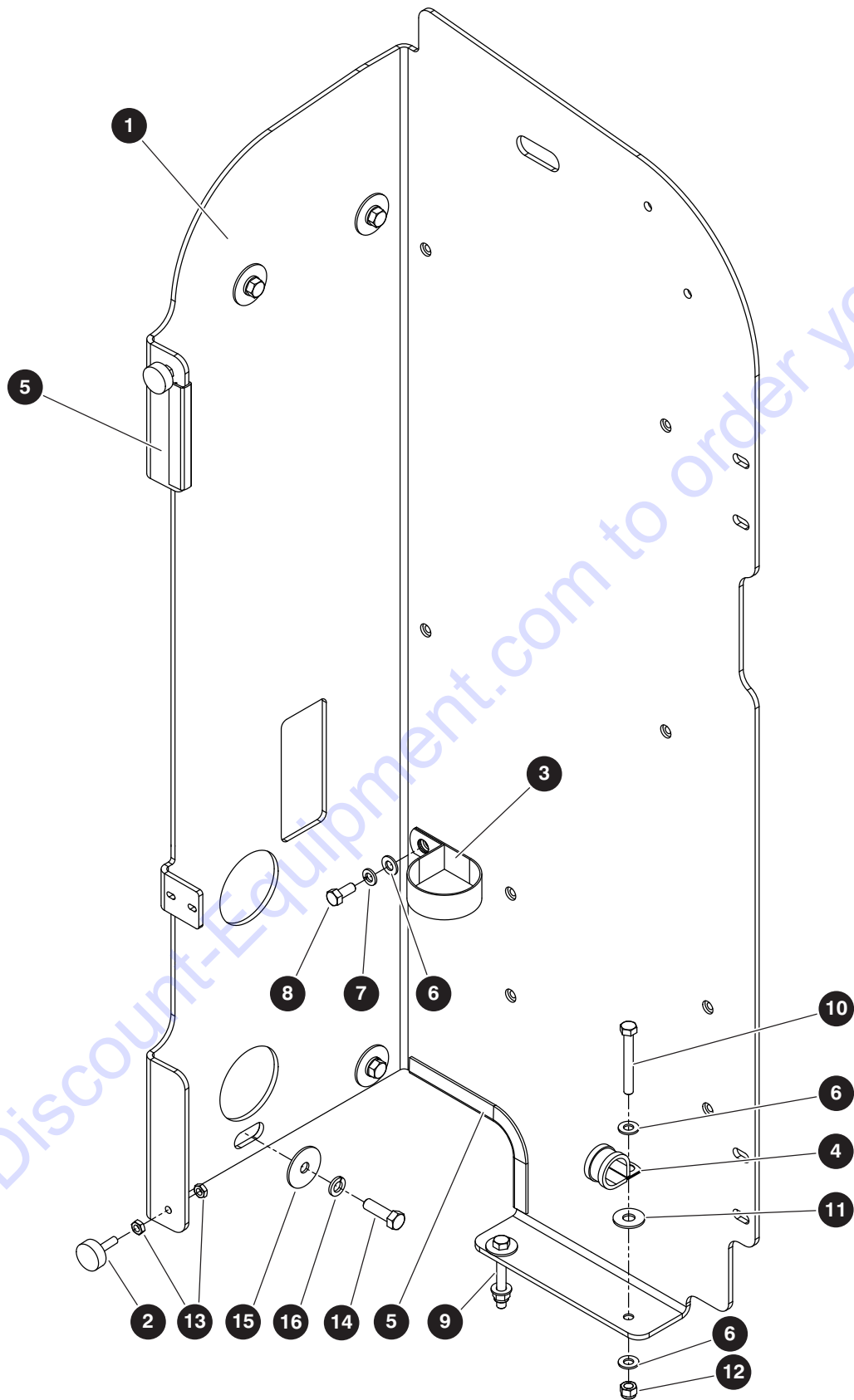

M192271AG

229034ADA

SJ30 AJE, SJ30 ARJE

4.2 Left Side Subcomponents

Index No.	Skyjack Part No.	Qty.	Description
-	192271	1	TURRET SUBCOMPONENTS - LEFT SIDE
1	192275	1	• WELDMENT, Left turret plate
2	144015	2	• MOUNT, Anti-vibration (0.25"-20 UNC)
3	143987	1	• CLAMP, Loop cushion (#40)
4	168707	1	• CLAMP, Tube (1")
5	117398	12"	• TRIM, Protective
6	103996	4	• WASHER, Flat (0.312" SAE)
7	103404	1	• WASHER, Lock (0.312")
8	103887	1	• BOLT, Hex head (0.312"-18 x 0.75" gr 5)
9	103866	1	• BOLT, Hex head (0.312"-18 x 2.25" gr 5)
10	103884	1	• BOLT, Hex head (0.312"-18 x 2.50" gr 5)
11	207341	2	• WASHER, Flat (0.312" x 1.25" fender)
12	103984	2	• NUT, Lock (0.13"-18 gr 5 nylon)
13	103983	4	• NUT, Hex head jam (0.25"-20 gr5)
14	101297	4	• BOLT, Hex head (0.375"-16 x 0.25" gr 5)
15	127067	4	• WASHER, Flat (0.375" style BB)
16	103999	4	• WASHER, Lock (0.375")

4.3 Right Side Subcomponents

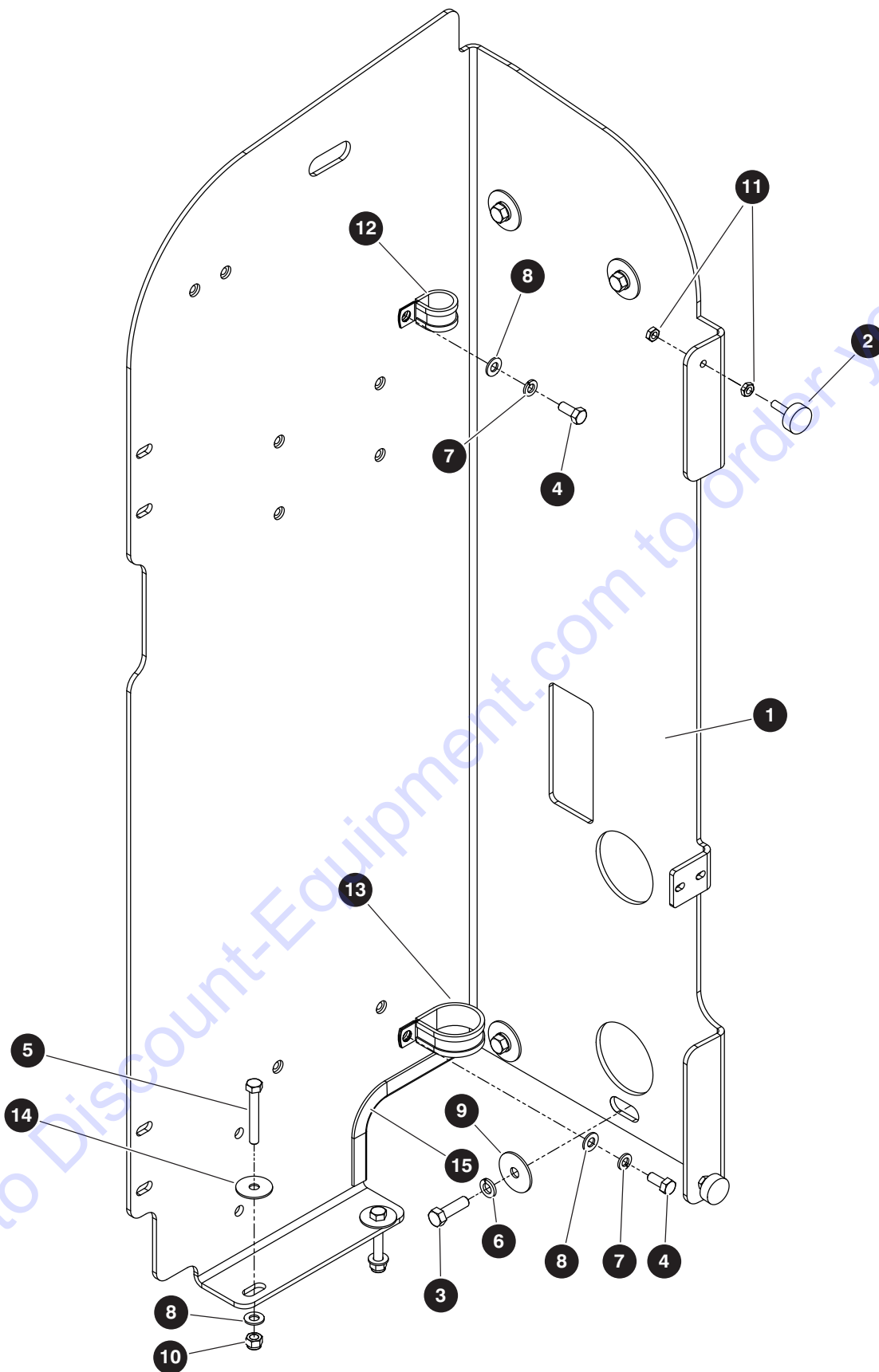

M192272AG

229034ADA

SJ30 AJE, SJ30 ARJE

4.3 Right Side Subcomponents

Index No.	Skyjack Part No.	Qty.	Description
-	192272	1	TURRET SUBCOMPONENTS - RIGHT SIDE
1	192276	1	• WELDMENT, Right turret plate
2	144015	2	• MOUNT, Anti-vibration (0.25"-20 UNC)
3	101297	4	• BOLT, Hex head (0.375"-16 x 0.25" gr 5)
4	103887	2	• BOLT, Hex head (0.312"-18 x 0.75" gr 5)
5	103866	2	• BOLT, Hex head (0.312"-18 x 2.25" gr 5)
6	103999	4	• WASHER, Lock (0.375")
7	103404	2	• WASHER, Lock (0.312")
8	103996	4	• WASHER, Flat (0.312" SAE)
9	127067	4	• WASHER, Flat (0.375" style BB)
10	103984	2	• NUT, Lock (0.13"-18 gr 5 nylon)
11	103983	4	• NUT, Hex head jam (0.25"-20 gr5)
12	168707	1	• CLAMP, Tube (1.00")
13	124433	1	• CLAMP, Tube (1.75")
14	207341	2	• WASHER, Flat (0.312" x 1.25 fender)
15	117398	8"	• TRIM, Protective

4.4 Lower Control Box

Index No.	Skyjack Part No.	Qty.	Description
A	192294	1	LOWER CONTROL BOX, ROTATING JIB - SJ30 ARJE ANSI/CSA & AS
B	207235	1	LOWER CONTROL BOX, ROTATING JIB - SJ30 ARJE CE
C	208951	1	LOWER CONTROL BOX, ROTATING JIB - SJ30 ARJE KC
D	207215	1	LOWER CONTROL BOX, NON-ROTATING JIB - SJ30 AJE ANSI/CSA
-	218320	1	• PANEL ASSEMBLY, Base, A
	218412	1	• PANEL ASSEMBLY, Base, B
	218413	1	• PANEL ASSEMBLY, Base, C
	218322	1	• PANEL ASSEMBLY, Base, D
-	192091	1	• • BOX, Base panel, A, D
	192137	1	• • BOX, Base panel, B
	208943	1	• • BOX, Base panel, C
1	192092	1	• • • BASE, Base control box
2	192093	1	• • • DOOR, Base control box, A, C, D
	192138	1	• • • DOOR, Base control box, B
3	192094	2	• • • STRIP, Weather (14")
4	149281	1	• • • HINGE, Continuous - steel
5	165005	4	• • • STUD, Pem (0.25"-20 x 0.625")
6	149336	4	• • • STUD, Pem (10-32 x 0.375")
7	149437	2	• • • BOLT, Fastener - 1/4 turn (large)
8	149321	2	• • • RECEPTACLE, Clip on 1/4 turn fastener
9	192109	2	• • • STRIP, Weather (7.875")
10	144647	1	• • SWITCH ASSEMBLY, E-stop
	147056	1	• • • LATCH, Mounting
	147229	1	• • • SWITCH, LED Block (Red)
	147053	2	• • • BLOCK, NC Contact
	147051	1	• • • SWITCH HEAD, E-Stop
11	138277	1	• • KEYSWITCH, 3 position, A, D
	144366	1	• • KEYSWITCH, 3 position, B, C
	138137	1	• • • KEY (#455)
	138136	1	• • • NUT, Key switch
12	116266	7	• • CONNECTOR, Strain relief (PG21)
13	102853	9	• • SWITCH, Toggle (1NT1-7), A, C, B
	102853	8	• • SWITCH, Toggle (1NT1-7), D
14	144016	10	• • SEAL, Toggle switch, A, B, C
	144016	9	• • SEAL, Toggle switch, D
15	137919	2	• • BREAKER, Circuit - 25 amp
16	192096	1	• • HARNESS, Motor controller (For components, refer to 5.2 Motor Controller Harness "A")
17	103056	1	• • BEEPER, 7.5 - 16 V DC, A, C, D
18	146652	1	• • HORN, Low tone - 12 V

4.4 Lower Control Box

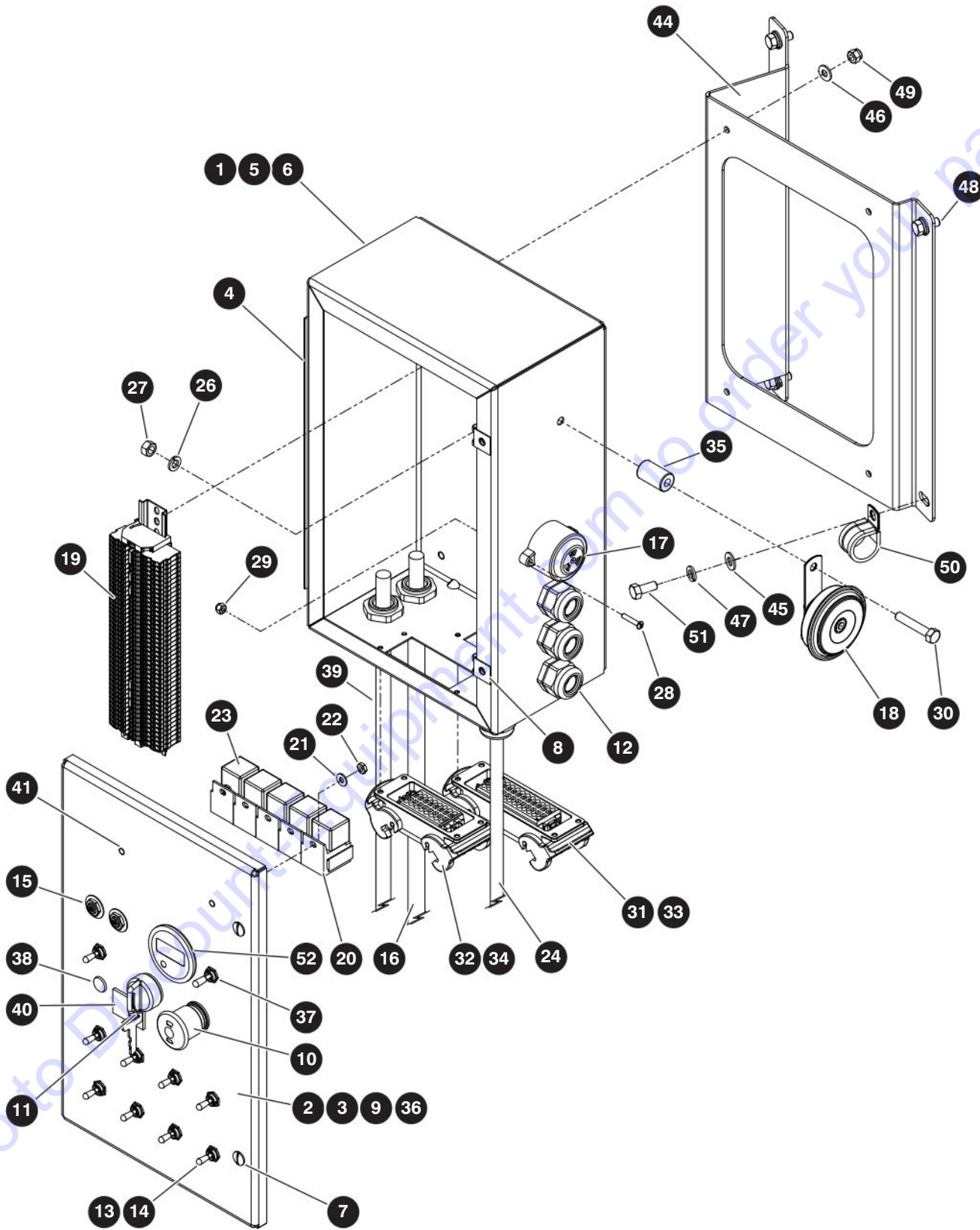

M207235AB

229034ADA

SJ30 AJE, SJ30 ARJE

4.4 Lower Control Box

Index No.	Skyjack Part No.	Qty.	Description
19	(Ref.)	1	<ul style="list-style-type: none"> • • TERMINAL BLOCK ASSEMBLY (For components, refer to 4.5 Terminal Block)
20	138749	7	<ul style="list-style-type: none"> • • SOCKET, Relay, A, D
	138749	9	<ul style="list-style-type: none"> • • SOCKET, Relay, B
	138749	13	<ul style="list-style-type: none"> • • SOCKET, Relay, C
21	104694	2	<ul style="list-style-type: none"> • • WASHER, Flat (#10) A, B, D
	104694	5	<ul style="list-style-type: none"> • • WASHER, Flat (#10), C
22	104003	2	<ul style="list-style-type: none"> • • NUT, Hex (10-32) A, B, D
	104003	5	<ul style="list-style-type: none"> • • NUT, Hex (10-32), C
23	127131	6	<ul style="list-style-type: none"> • • RELAY, 12 V 40 amp, A, D
	127131	7	<ul style="list-style-type: none"> • • RELAY, 12 V 40 amp, B
	127131	12	<ul style="list-style-type: none"> • • RELAY, 12 V 40 amp, C
24	192101	1	<ul style="list-style-type: none"> • • HARNESS, Main manifold, A, B, D
	209042	1	<ul style="list-style-type: none"> • • HARNESS, Main manifold, C (For components, refer to 5.4 Main Manifold Harness)
25	(Ref.)	1	<ul style="list-style-type: none"> • • WIRING ASSEMBLY, Base (not shown)
	102921	18	<ul style="list-style-type: none"> • • • DIODE (T6A40L), A, C, D
	102921	20	<ul style="list-style-type: none"> • • • DIODE (T6A40L), B
	144492	1	<ul style="list-style-type: none"> • • • RESISTOR, 680 ohm 1 watt axial lead
	164511	1	<ul style="list-style-type: none"> • • • CAPACITOR, 25 V (10000 UF)
26	103404	1	<ul style="list-style-type: none"> • • WASHER, Lock (0.312")
27	100397	2	<ul style="list-style-type: none"> • • NUT, Hex (0.312"-18 gr 5)
28	126499	2	<ul style="list-style-type: none"> • • SCREW, Round head machine (8-32 x 0.875")
29	138765	1	<ul style="list-style-type: none"> • • NUT, Lock (8-32 gr 5 nylon)
30	103865	1	<ul style="list-style-type: none"> • • BOLT, Hex head (0.312"-18 x 2.00" gr 5)
31	138751	1	<ul style="list-style-type: none"> • • HOUSING, Open bottom - 24 pole levered
32	192082	1	<ul style="list-style-type: none"> • • HOUSING, Open bottom - 16 pole
33	138755	1	<ul style="list-style-type: none"> • • PLUG, 24 pol spring 16A
34	192093	1	<ul style="list-style-type: none"> • • SOCKET, 16 pole spring
35	192286	1	<ul style="list-style-type: none"> • • SPACER (0.315 ID x 0.75" OD x 1.25" lg)
36	173058	1	<ul style="list-style-type: none"> • • LABEL, Base controls
37	138278	1	<ul style="list-style-type: none"> • • SWITCH, Toggle (2NT1-7)
38	164832	1	<ul style="list-style-type: none"> • • LIGHT, Indicator - red (12 V)
39	207820	1	<ul style="list-style-type: none"> • • HARNESS, Motor controller "B" (For components, refer to 5.3 Motor Controller Harness "B")
40	192139	1	<ul style="list-style-type: none"> • • COUNTER, With reset, B
41	115545	3	<ul style="list-style-type: none"> • • SCREW, Round head machine (10-32 x 0.375"), C
42	221144	1	<ul style="list-style-type: none"> • • HARNESS, Elevate trackunit telematics (not shown)
43	221158	1	<ul style="list-style-type: none"> • • LABEL, 01DCR (not shown)

4.4 Lower Control Box

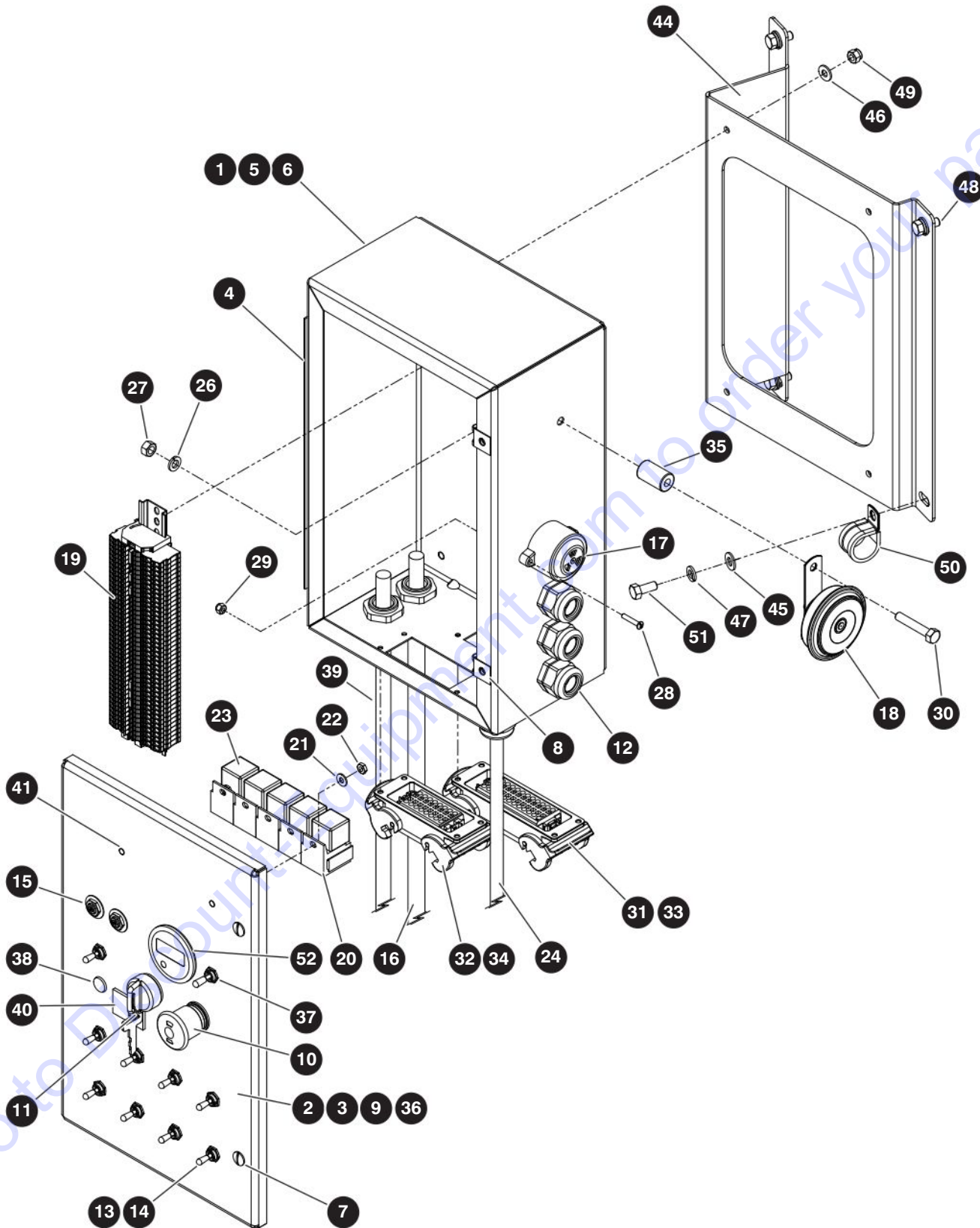

M207235AB

229034ADA

SJ30 AJE, SJ30 ARJE

4.4 Lower Control Box

Index No.	Skyjack Part No.	Qty.	Description
44	192277	1	• BRACKET, Control box mounting
45	103996	4	• WASHER, Flat (0.312" SAE)
46	103995	4	• WASHER, Flat (0.25" SAE)
47	103404	4	• WASHER, Lock (0.312")
48	103887	3	• BOLT, Hex head (0.312"-18 x 0.75" gr 5)
49	115649	4	• NUT, Lock (0.25"-20 gr 5 nylon)
50	168707	1	• CLAMP, Tube (1")
51	207266	1	• BOLT, Hex head (0.312"-18 x 0.875" gr 5)
52	221981	1	DISPLAY, MDI CAN

4.5 Terminal Block

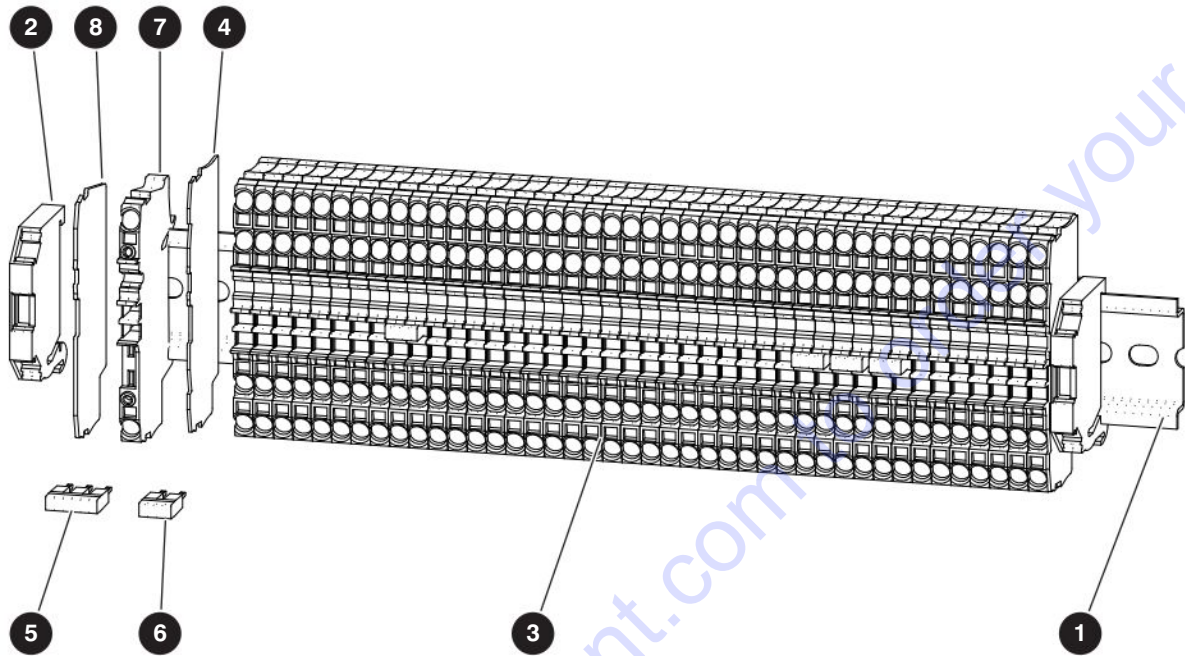

M210425AA

Index No.	Skyjack Part No.	Qty.	Description
A	192108	1	TERMINAL BLOCK ASSEMBLY - ANSI/CSA, AS & KC
B	210425	1	TERMINAL BLOCK ASSEMBLY WITH FUSE HOLDER - CE
1	133148	1	<ul style="list-style-type: none"> • TRACK, Relay (11")
2	707147	2	<ul style="list-style-type: none"> • STOP, End
3	137940	45	<ul style="list-style-type: none"> • BLOCK, Terminal
4	137941	2	<ul style="list-style-type: none"> • PLATE, End
5	137943	1	<ul style="list-style-type: none"> • JUMPER, 3 pin
6	137942	5	<ul style="list-style-type: none"> • JUMPER, 2 pin
7	170607	1	<ul style="list-style-type: none"> • TERMINAL, Fuse (2 cond), B
8	170606	1	<ul style="list-style-type: none"> • PLATE, End - terminal, B

4.6 Direction Sensing Switch

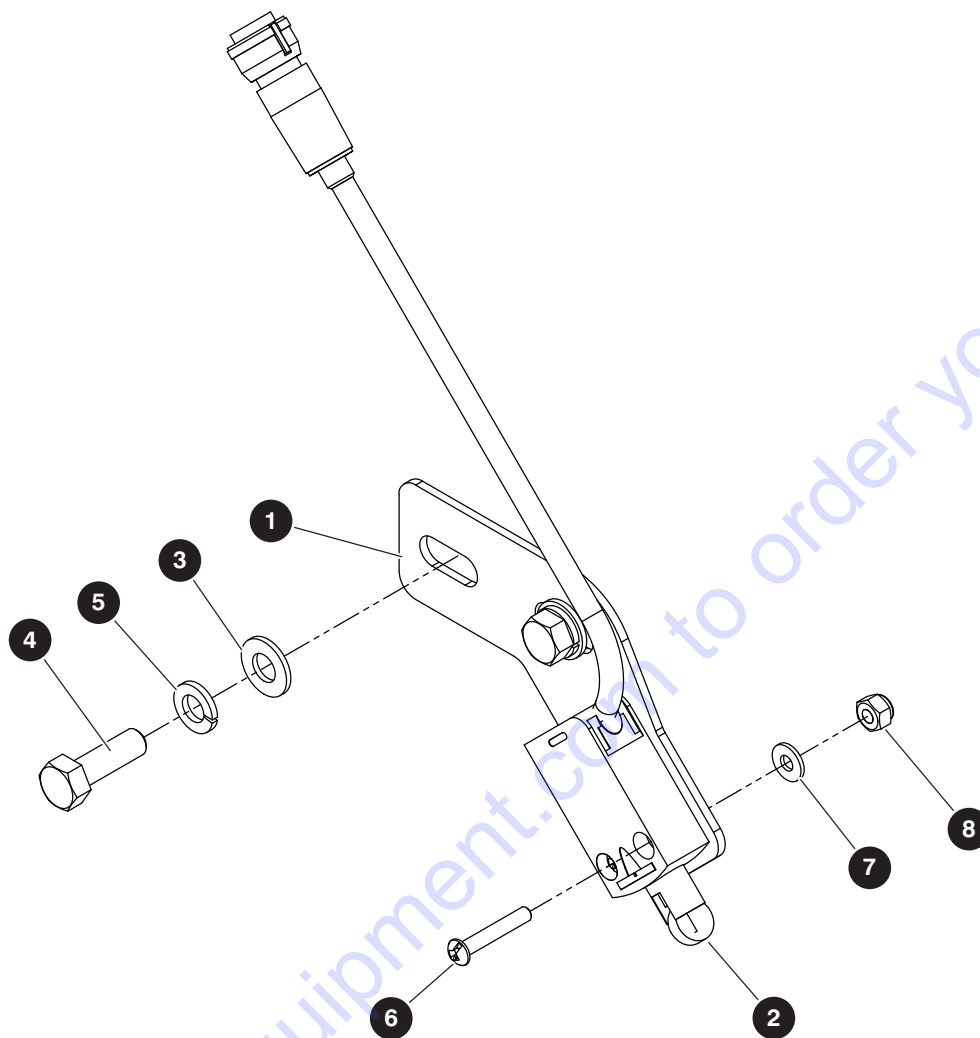

M192639AC

Index No.	Skyjack Part No.	Qty.	Description
-	192639	1	DIRECTION SENSING SWITCH
1	192846	1	• BRACKET, Direction sensing switch
2	211448	1	• LIMIT SWITCH ASSEMBLY, Roller plunger
3	103996	2	• WASHER, Flat (0.312" SAE)
4	103864	2	• BOLT, Hex head (0.312"-18 x 1.00" gr 5)
5	103404	2	• WASHER, Lock (0.312")
6	112248	2	• SCREW, Round head machien (8-32 x 1.00")
7	103391	2	• WASHER, Flat (#8)
8	138765	2	• NUT, Lock (8-32 gr 5 nylon)
9	207402	1	• CORD, Limit switch (55")

4.7 Main Pump

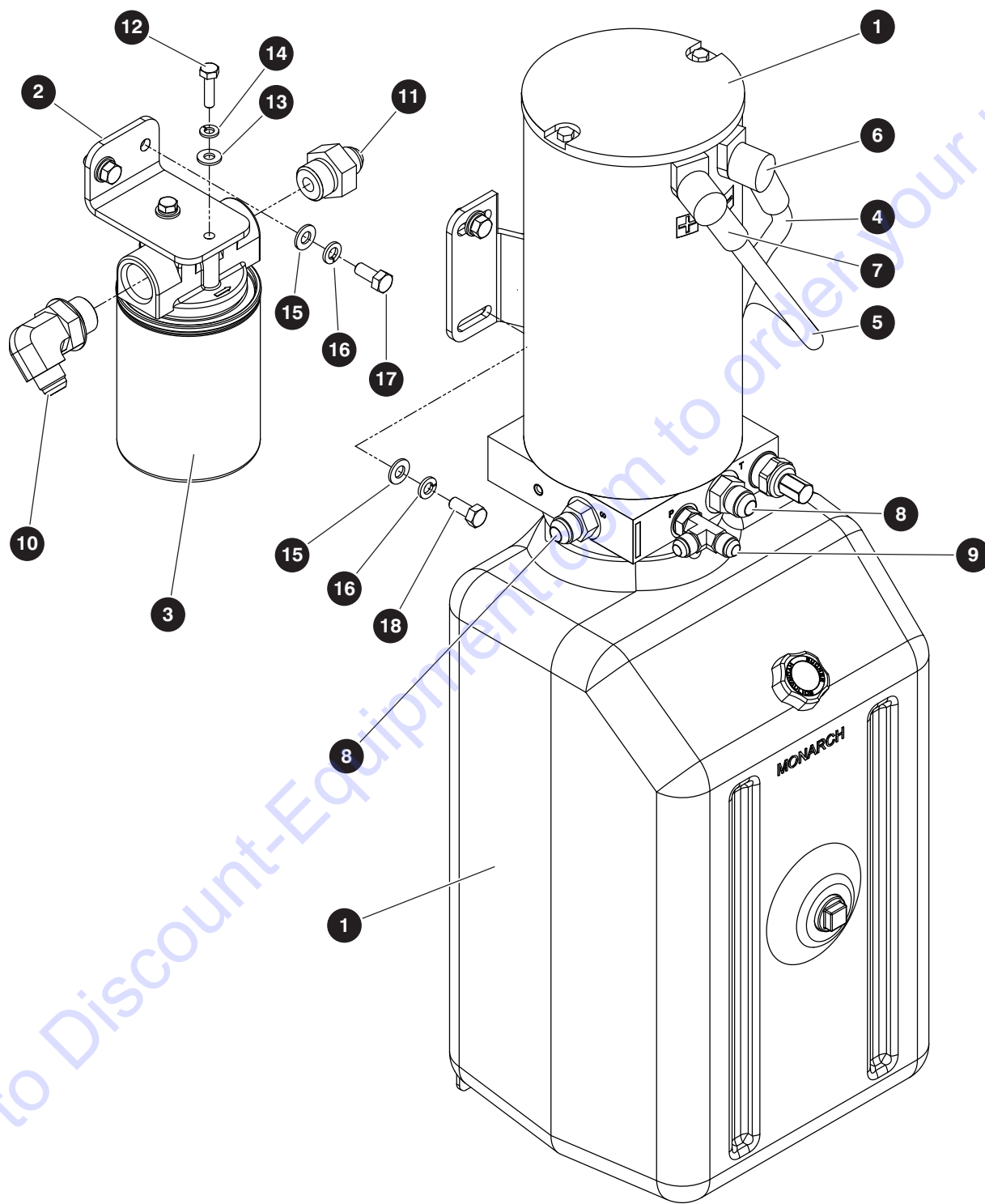

M192292AF

229034ADA

98

SJ30 AJE, SJ30 ARJE

SKYJACK

4.7 Main Pump

Index No.	Skyjack Part No.	Qty.	Description
-	192292	1	PUMP MOTOR ASSEMBLY
1	192160	1	• ASSEMBLY, Pump motor
	209056	1	• • PUMP
	209057	1	• • MOTOR, 48V DC
	209058	1	• • VALVE, Relief
	209059	1	• • O-RING, Base to pump front end
	209060	1	• • O-RING, Rear cover
	169438	2	• • FILTER, Screen
	209061	1	• • RESERVOIR, Plastic (9 x 10 x 18)
	209062	1	• • PLUG, Reservoir breather-filler
	169433	1	• • CLAMP, Hose worm
	209063	1	• • LABEL, Fill line
	209064	1	• • LABEL, For vertical mounting only
2	192295	1	• PLATE, Filter mount
3	136405	1	• FILTER, Spin on assembly
	136403	1	• • HEAD, Oil filter
	108628	1	• • FILTER, Spin on
4	192187	1	• CABLE, 1GA (0.3125" x 108" x 0.3125" (-,-))
5	192188	1	• CABLE, 1GA (0.3125" x 108" x 0.3125" (+,+))
6	117407	2	• INSULATOR, Boot (black)
7	117408	1	• INSULATOR, Boot (red)
8	102659	2	• FITTING, Straight (08JICM-08ORBM)
9	114581	1	• FITTING, Run tee (06JICM-06ORBM-06JICM)
10	112366	1	• FITTING, 90° (08JICM-12ORBM)
11	105446	1	• FITTING, Straight (12ORBM-08JICM)
12	103856	2	• BOLT, Hex head (0.25"-20 x 0.75" gr 5)
13	103995	2	• WASHER, Flat (0.25" SAE)
14	104000	2	• WASHER, Lock (0.25")
15	103996	8	• WASHER, Flat (0.312" SAE)
16	103404	10	• WASHER, Lock (0.312")
17	103864	2	• BOLT, Hex head (0.312"-18 x 1.00" gr 5)
18	103887	6	• BOLT, Hex head (0.312"-18 x 0.75" gr 5)
19	924699	12"	• WRAP, Spiral (not shown)

4.8 Emergency Pump

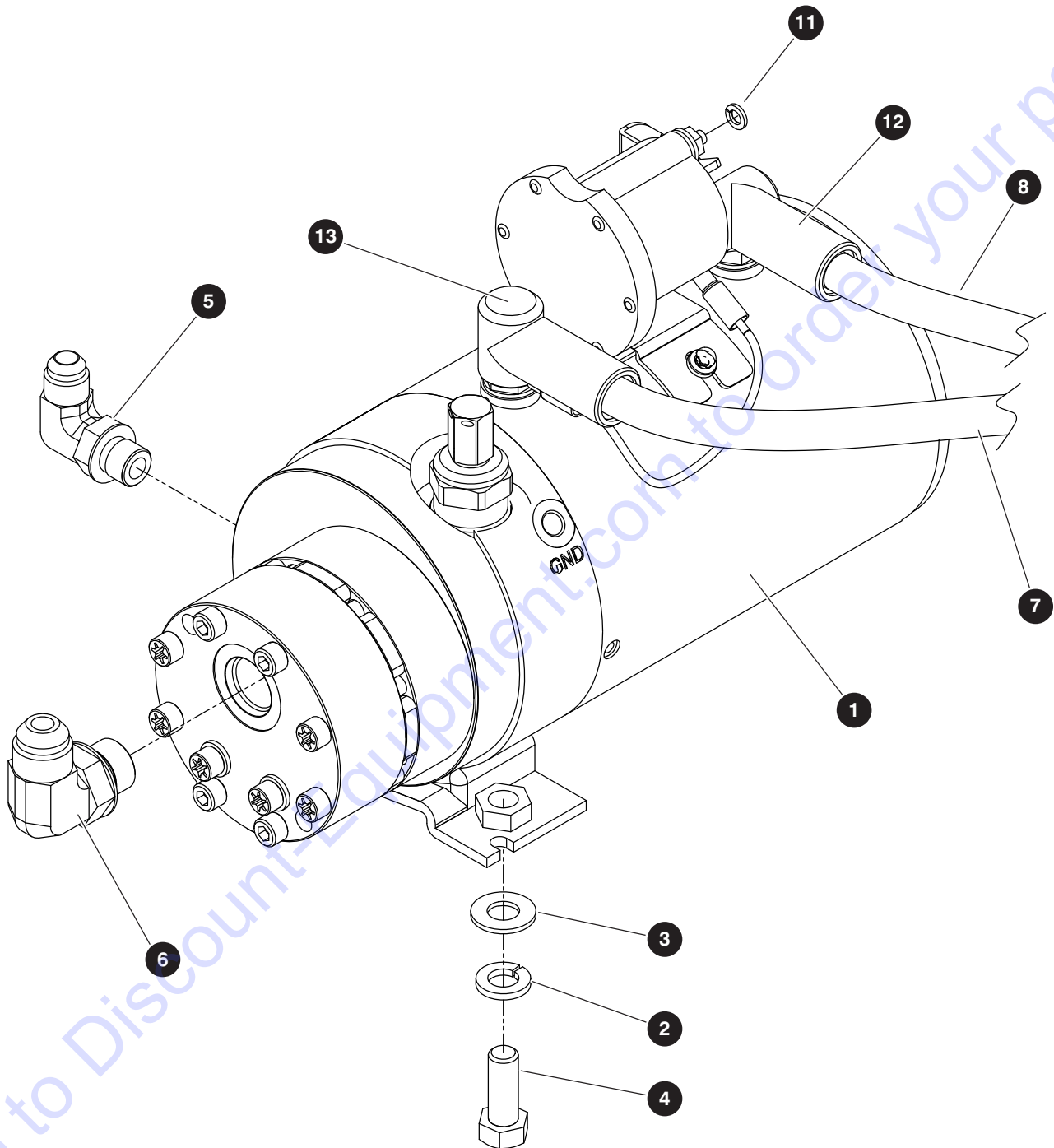

M192293AC

229034ADA

100

SJ30 AJE, SJ30 ARJE

SKYJACK

4.8 Emergency Pump

Index No.	Skyjack Part No.	Qty.	Description
-	192293	1	EMERGENCY PUMP
1	192069	1	• PUMP MOTOR ASSEMBLY, Emergency
	192176	1	• • PUMP
	209065	1	• • MOTOR
	209058	1	• • VALVE, Relief
	168898	1	• • SWITCH, Solenoid
	209067	1	• • STRAP, Motor/solenoid connecting
	209068	1	• • WIRE ASSEMBLY, Control
	209069	1	• • O-RING (0.50")
	209076	1	• • O-RING (2.25")
2	103999	2	• WASHER, Lock (0.375")
3	103472	2	• WASHER, Flat (0.375" SAE)
4	103473	2	• BOLT, Hex head (0.375"-16 x 1.00" gr 5)
5	114578	1	• FITTING, 90° (06JICM-06ORBM)
6	114583	1	• FITTING, 90° (08JICM-08ORBM)
7	192183	1	• CABLE, 1GA (0.3125" x 60" x 0.3125" (-,-))
8	192184	1	• CABLE, 1GA (0.3125" x 45" x 0.3125" (+,+))
9	192102	1	• HARNESS, E-Pump (not shown)
10	924699	12"	• WRAP, Spiral (not shown)
11	104185	1	• WASHER, Lock (#10)
12	117408	1	• INSULATOR, Boot (red)
13	117407	1	• INSULATOR, Boot (black)

4.9 Main Manifold

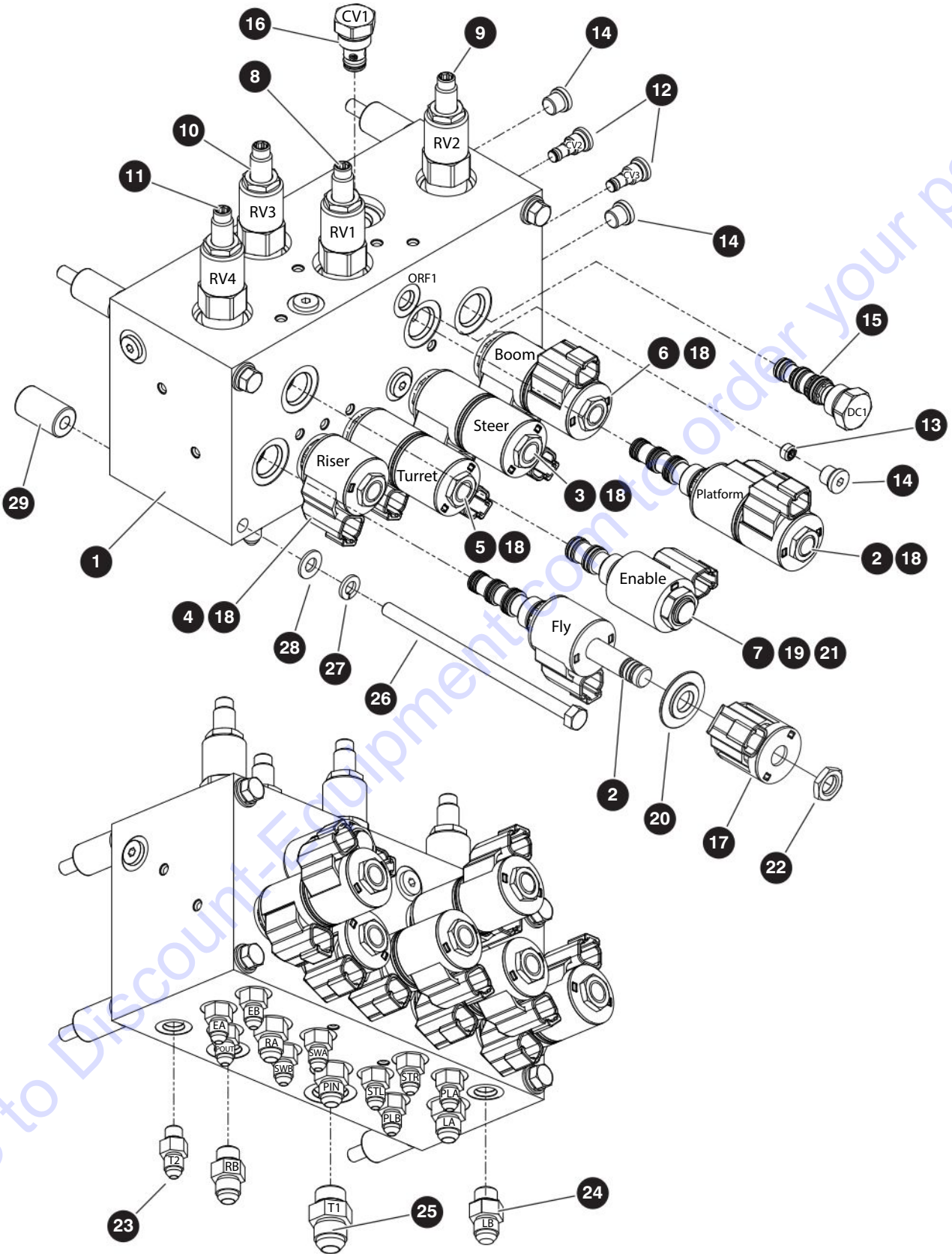

M192291AC

229034ADA

SJ30 AJE, SJ30 ARJE

PARTS FINDER

**Search Website
by Part Number**



**Search Manual
Library For Parts
Manual & Lookup Part
Numbers – Purchase
or Request Quote**

Search Manuals

Enter your information to help us find the right parts manual for your machine.

* Brand:

* Model:

* Serial:

* Part Number:

SEARCH

**Can't Find Part or
Manual? Request Help
by Manufacturer,
Model & Description**

Parts Order Form

Please fill in the following information to help us find the right part for your machine.

Manufacturer:	<input type="text"/>
Model:	<input type="text"/>
Description:	<input type="text"/>
Part Number:	<input type="text"/>
Quantity:	<input type="text"/>
Notes:	<input type="text"/>

Discount-Equipment.com is your online resource for quality parts & equipment.

Florida: **561-964-4949** Outside Florida TOLL FREE: **877-690-3101**

Need parts?

Click on this link: <http://www.discount-equipment.com/category/5443-parts/> and choose one of the options to help get the right parts and equipment you are looking for. Please have the machine model and serial number available in order to help us get you the correct parts. If you don't find the part on the website or on one of the online manuals, please fill out the request form and one of our experienced staff members will get back to you with a quote for the right part that your machine needs.

We sell worldwide for the brands: Genie, Terex, JLG, MultiQuip, Mikasa, Essick, Whiteman, Mayco, Toro Stone, Diamond Products, Generac Magnum, Airman, Haulotte, Barreto, Power Blanket, Nifty Lift, Atlas Copco, Chicago Pneumatic, Allmand, Miller Curber, Skyjack, Lull, Skytrak, Tsurumi, Husquvarna Target, Stow, Wacker, Sakai, Mi-T-M, Sullair, Basic, Dynapac, MBW, Weber, Bartell, Bennar Newman, Haulotte, Ditch Runner, Menegotti, Morrison, Contec, Buddy, Crown, Edco, Wyco, Bomag, Laymor, EZ Trench, Bil-Jax, F.S. Curtis, Gehl Pavers, Heli, Honda, ICS/PowerGrit, IHI, Partner, Imer, Clipper, MMD, Koshin, Rice, CH&E, General Equipment, Amida, Coleman, NAC, Gradall, Square Shooter, Kent, Stanley, Tamco, Toku, Hatz, Kohler, Robin, Wisconsin, Northrock, Oztec, Toker TK, Rol-Air, APT, Wylie, Ingersoll Rand / Doosan, Innovatech, Con X, Ammann, Mecalac, Makinex, Smith Surface Prep, Small Line, Wanco, Yanmar

4.9 Main Manifold

Index No.	Skyjack Part No.	Qty.	Description
-	192291	1	MAIN MANIFOLD
-	192161	1	• MANIFOLD, Main
1	208871	1	• • BLOCK, Manifold
2	166036	2	• • VALVE, Spool (4 way, 3 position)
3	208872	1	• • VALVE, Spool (4 way, 3 position)
4	208874	1	• • VALVE, Poppet (2 way NC)
5	208875	1	• • VALVE, Spool (5 way, 3 position)
6	166041	1	• • VALVE, Spool (4 way, 3 position)
7	166050	1	• • VALVE, Cartridge - proportional flow control
8	208876	1	• • VALVE, Relief
9	208877	1	• • VALVE, Relief
10	208878	1	• • VALVE, Relief
11	208879	1	• • VALVE, Relief
12	197770	2	• • VALVE, Check
13	208880	1	• • PLUG, Orifice
14	709963	7	• • PLUG, Port
15	208883	1	• • VALVE, Check
16	199471	1	• • VALVE, Check
17	159821	2	• • COIL, Solenoid
18	208881	9	• • COIL, Solenoid
19	166127	1	• • COIL, Solenoid
20	208911	5	• • SPACER
21	208909	1	• • NUT
22	208910	6	• • NUT
23	126128	10	• • FITTING, Straight (04JICM-04ORBM)
24	103069	5	• • FITTING, Straight (06JICM-06ORBM)
25	102659	1	• • FITTING, Straight (08JICM-08ORBM)
26	162714	4	• BOLT, Hex head (0.312"-18 x 6.00" gr 5)
27	103404	4	• WASHER, Lock (0.312")
28	103996	4	• WASHER, Flat (0.312" SAE)
29	192286	4	• SPACER, 0.315" ID x 0.75" OD x 1.25" lg)

4.10 Left Cowling

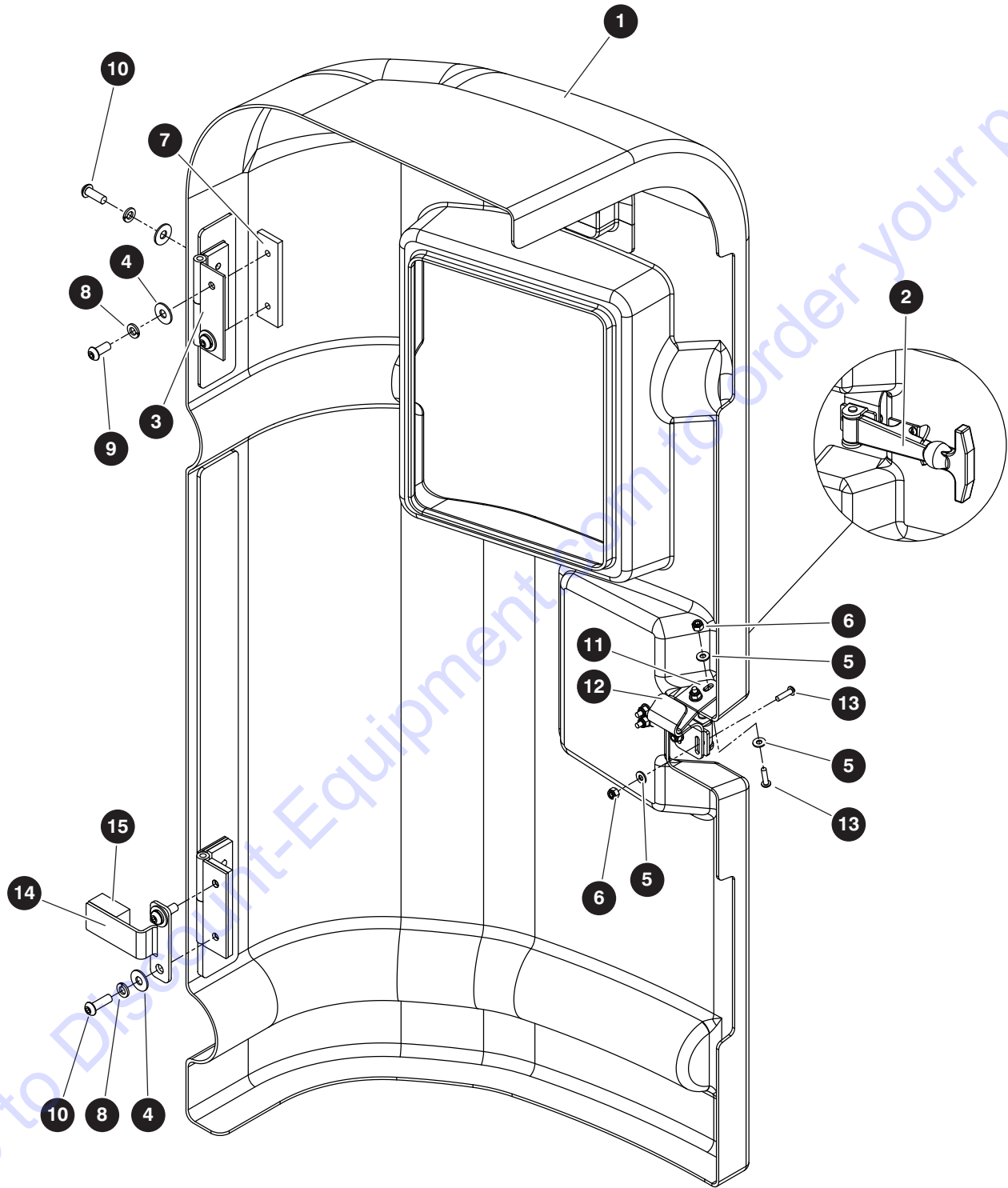

M192269AF

229034ADA

104

SJ30 AJE, SJ30 ARJE

SKYJACK

4.10 Left Cowling

Index No.	Skyjack Part No.	Qty.	Description
-	192754	1	LEFT COWLING
1	192737	1	• COWLING, Left shell
2	144002	1	• LATCH, Flexible draw
3	192288	2	• HINGE, Lift off - LH (4.00")
4	166164	8	• WASHER, Flat (0.312" USS)
5	104694	8	• WASHER, Flat (#10)
6	126642	6	• NUT, Lock (10-24 gr 5 nylon)
7	192298	4	• PLATE, Cowling - tapped
8	103404	8	• WASHER, Lock (0.312")
9	300064	2	• BOLT, Button head cap screw (0.313"-18 x 0.75")
10	221787	6	• BOLT, Button head cap screw (0.313"-18 x 1.25")
11	192838	1	• PLATE, Alignment - cowling side
12	192837	1	• PLATE, Alignment - turret side
13	192776	6	• BOLT, Button head cap screw (10-24 x 0.75")
14	192796	1	• PLATE, Cowling stopper
15	192849	0.125"	• FOAM

4.11 Right Cowling

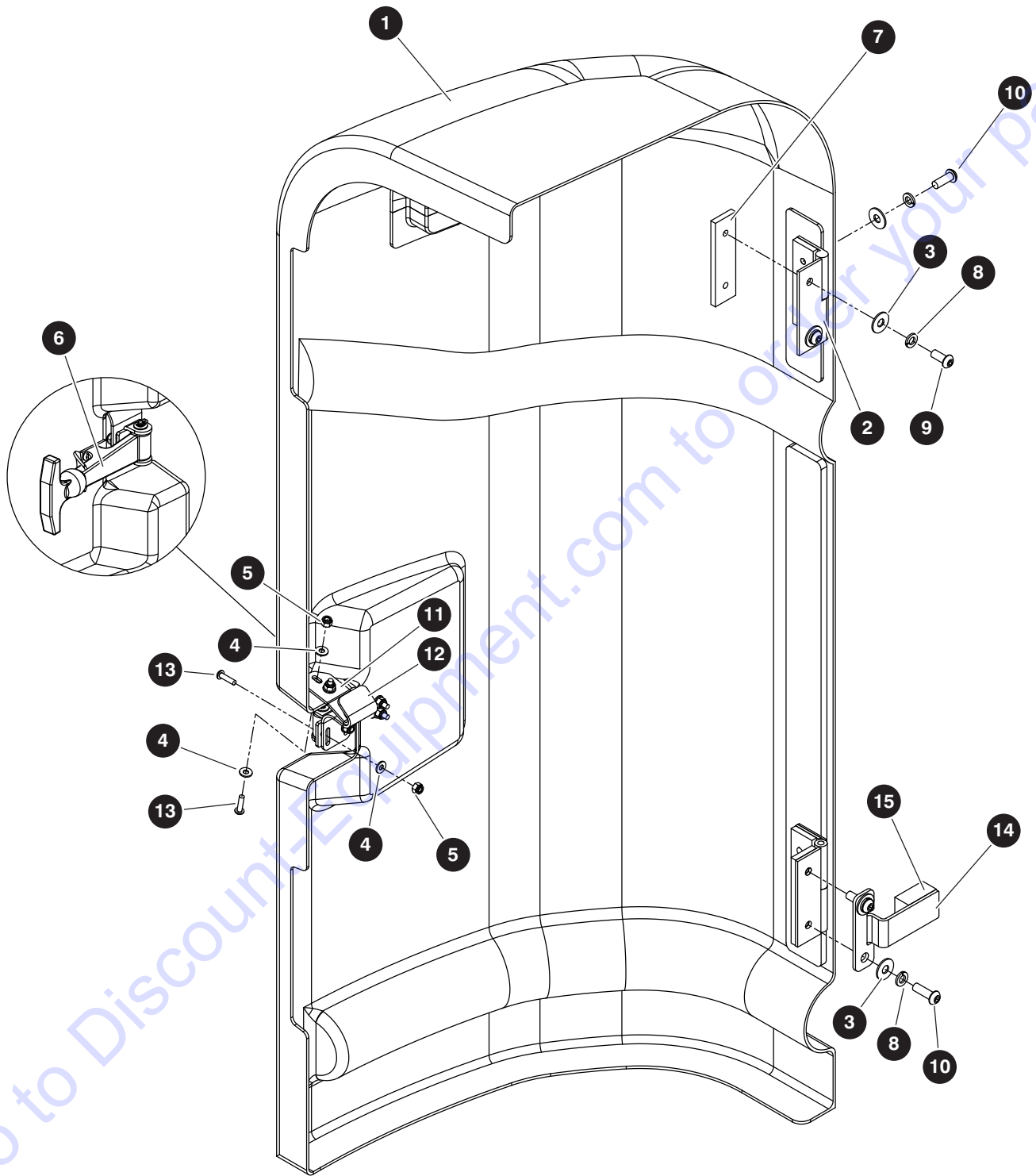

M192270AF

229034ADA

106

SJ30 AJE, SJ30 ARJE

SKYJACK

4.11 Right Cowling

Index No.	Skyjack Part No.	Qty.	Description
-	207401	1	RIGHT COWLING
1	192738	1	• COWLING, Right shell
2	192289	2	• HINGE, Lift off - RH (4.00")
3	166164	8	• WASHER, Flat (0.312" USS)
4	104694	8	• WASHER, Flat (#10)
5	126642	6	• NUT, Lock (10-24 gr 5 nylon)
6	144002	1	• LATCH, Flexible draw
7	192298	4	• PLATE, Cowling - tapped
8	103404	8	• WASHER, Lock (0.312")
9	300064	2	• BOLT, Button head cap screw (0.313"-18 x 0.75")
10	221787	6	• BOLT, Button head cap screw (0.313"-18 x 1.25")
11	192838	1	• PLATE, Alignment - cowling side
12	192837	1	• PLATE, Alignment - turret side
13	192776	6	• BOLT, Button head cap screw (10-24 x 0.75")
14	192796	1	• PLATE, Cowling stopper
15	192849	0.125"	• FOAM

4.12 Counterweights

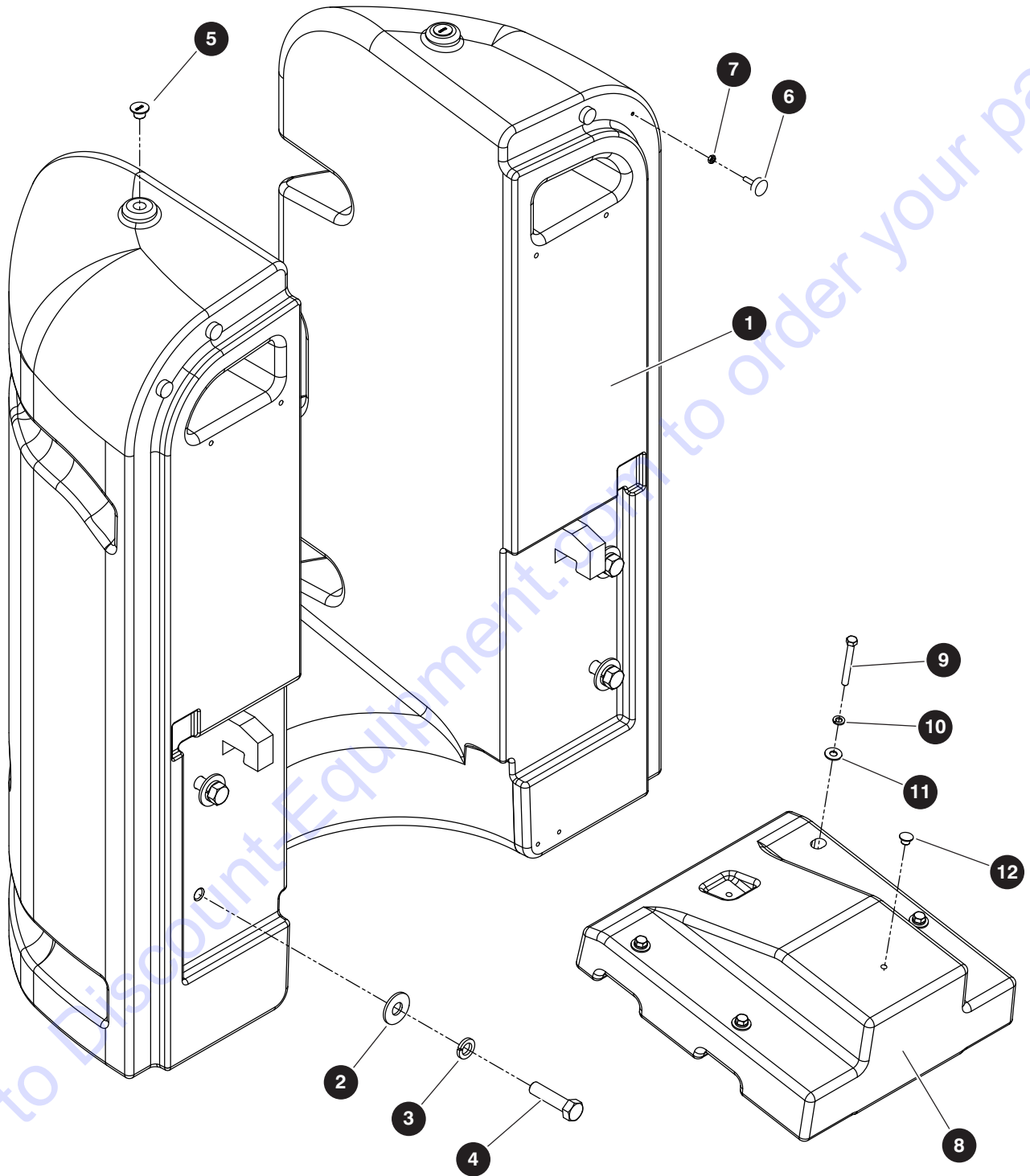

M192860AB

229034ADA

108

SJ30 AJE, SJ30 ARJE

SKYJACK

4.12 Counterweights

Index No.	Skyjack Part No.	Qty.	Description
A	192865	1	COUNTERWEIGHT ASSEMBLY - ANSI/CSA & AS
B	192860	1	COUNTERWEIGHT ASSEMBLY - CE & KC
-	192861	1	• TURRET COUNTERWEIGHT ASSEMBLY
1	192862	1	• • COUNTERWEIGHT, Turret
2	113304	4	• • WASHER, Flat (0.75" USS)
3	104002	4	• • WASHER, Lock (0.75")
4	103894	4	• • BOLT, Hex head (0.75-10 x 3.00" gr 8)
5	197257	2	• • PLUG, Hole - threaded (0.75")
6	144015	4	• • MOUNT, Anti-vibration (0.25"-20 UNC)
7	103983	4	• • NUT, Hex head jam (0.25"-20 gr 5)
-	192882	1	• RISER COUNTERWEIGHT ASSEMBLY, B
8	192468	1	• • COUNTERWEIGHT, Riser
9	103916	4	• • BOLT, Hex head (0.375-16 x 3.25" gr 5)
10	103999	4	• • WASHER, Lock (0.75")
11	207267	4	• • WASHER, Flat (0.375" thick fender)
12	197516	2	• • PLUG, (0.375" tapered)

4.13 Grease Line

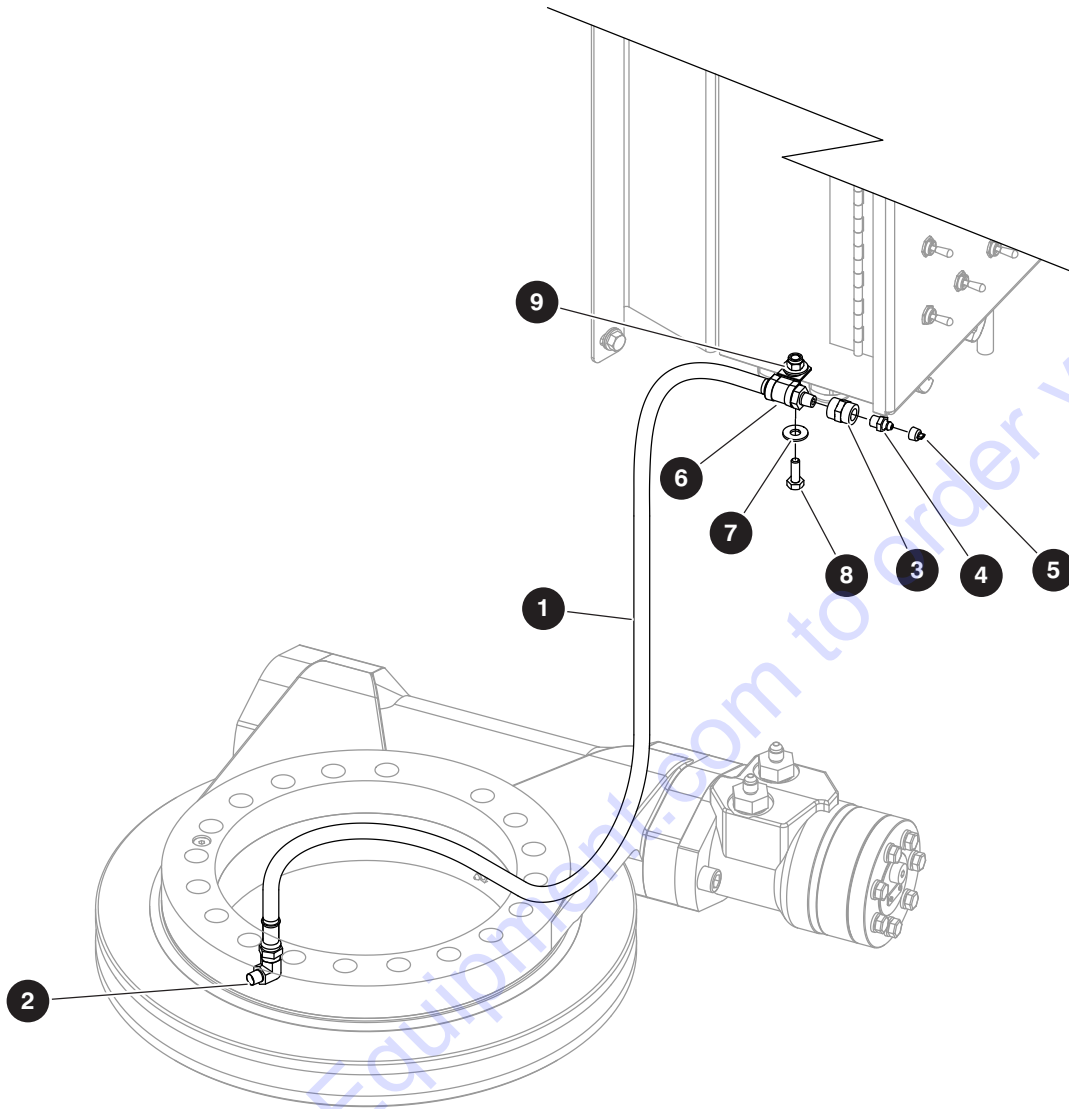

M192860AA

Index No.	Skyjack Part No.	Qty.	Description
-	192845	1	GREASE LINE
1	192579	1	• HOSE, Grease line
2	139094	1	• FITTING, 90° (1/8 NPTM - 1/8 NPTF)
3	139095	1	• FITTING, Straight (1/8 NPTF - 1/8 NPTF)
4	102027	1	• FITTING, Grease (1/8 NPT straight)
5	132565	1	• CAP, Grease (GC5)
6	144129	1	• CLIP, Single (S332G10)
7	192635	2	• WASHER, Flat (0.25" USS)
8	103856	1	• BOLT, Hex head (0.25"-20 x 0.75" gr 5)
9	115649	1	• NUT, Lock (0.25"-20 gr 5 nylon)

Section 5 – Electrical Harnesses

5.1 *Control Cables*

5.2 *Motor Controller Harness "A"*

5.3 *Motor Controller Harness "B"*

5.4 *Main Manifold Harness*

5.5 *Steering Sensor Harness*

5.6 *Charger Harness*

5.7 *Riser Cylinder Lowering Harness*

5.8 *Anti - Overriding Posts Harness - KC*

5.9 *Upper Control Harness - KC*

5.10 *Lower Control Harness - KC*

5.1 Control Cables

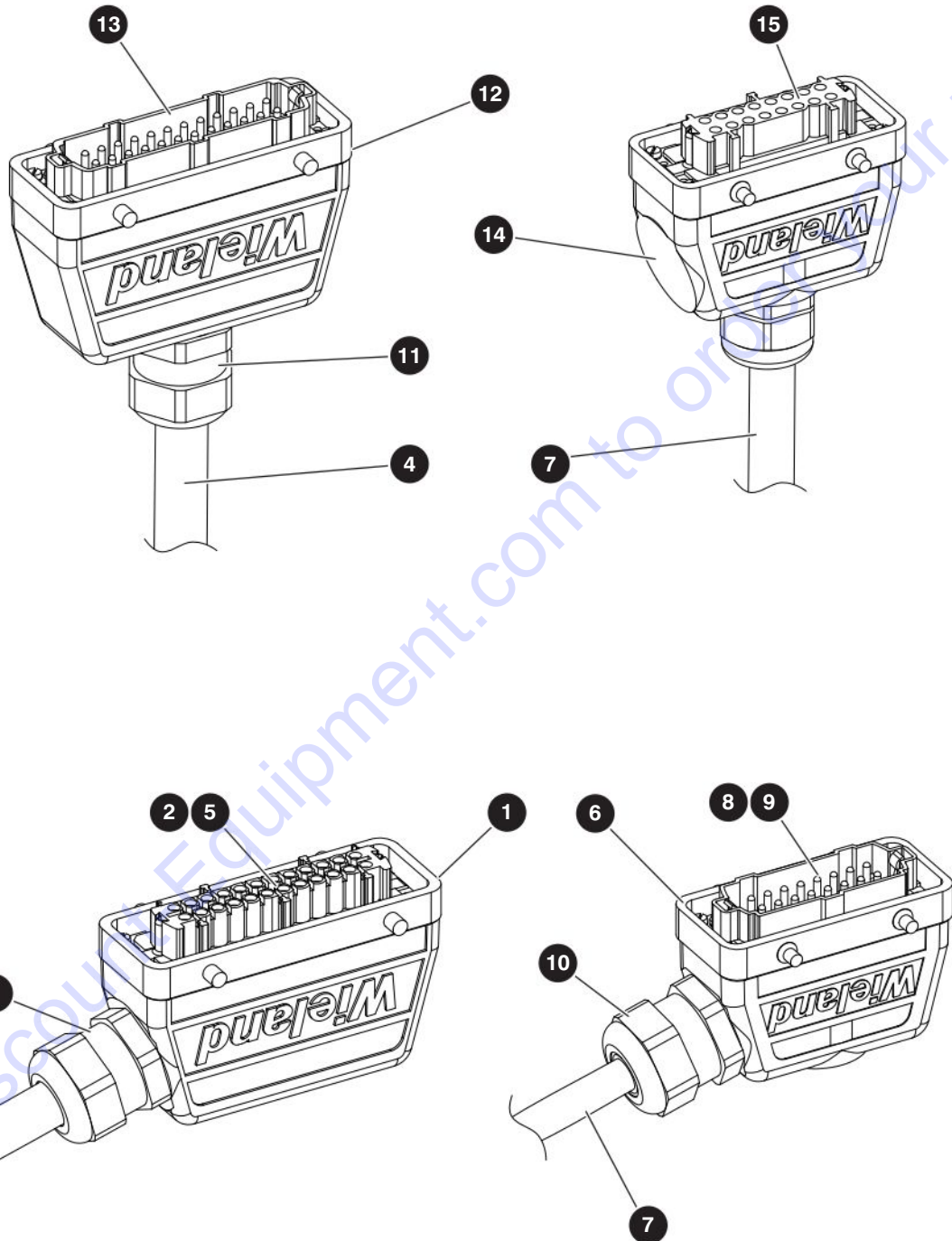

M192096AB

229034ADA

SJ30 AJE, SJ30 ARJE

5.1 Control Cables

Index No.	Skyjack Part No.	Qty.	Description
-	192712	1	CONTROL CABLES
-	192164	1	• CABLE, Control - A, serial number A300 000 018 & below
-	223776	1	• CABLE, Control - A, serial number A300 000 019 & above
1	138753	1	• • HOOD, Side 24 pole M32
2	138756	1	• • SOCKET, 24 pole spring 16A
3	138754	1	• • RELIEF, Strain (M32 x 1.5)
4	192165	1	• • CABLE, Cut - 16/24 (510"), serial number A300 000 018 & below
	223778	1	• • CABLE, Cut - 16/24 (510"), serial number A300 000 019 & above
5	121050	24	• • CONNECTOR, Ferrule 16GA
-	192166	1	• CABLE, Control - B, serial number A300 000 018 & below
-	223777	1	• CABLE, Control - B, serial number A300 000 019 & above
6	192167	1	• • CABLE, Cut - 16/16 (510"), serial number A300 000 018 & below
	223779	1	• • CABLE, Cut - 16/16 (510"), serial number A300 000 019 & above
7	192084	1	• • PLUG, 16 pole spring
8	121050	16	• • CONNECTOR, Ferrule 16GA
9	192087	1	• • HOOD, Side 16 pole M32, dual hinge
10	138754	1	• • RELIEF, Strain (M32 x 1.5)
11	138754	1	• RELIEF, Strain (M32 x 1.5)
12	138752	1	• HOOD, Top 24 pole M32
13	138755	1	• PLUG, 24 pole spring 16A
14	163173	1	• HOUSING, Top - double hinge
15	192083	1	• SOCKET, 16 pole - spring

5.2 Motor Controller Harness "A"

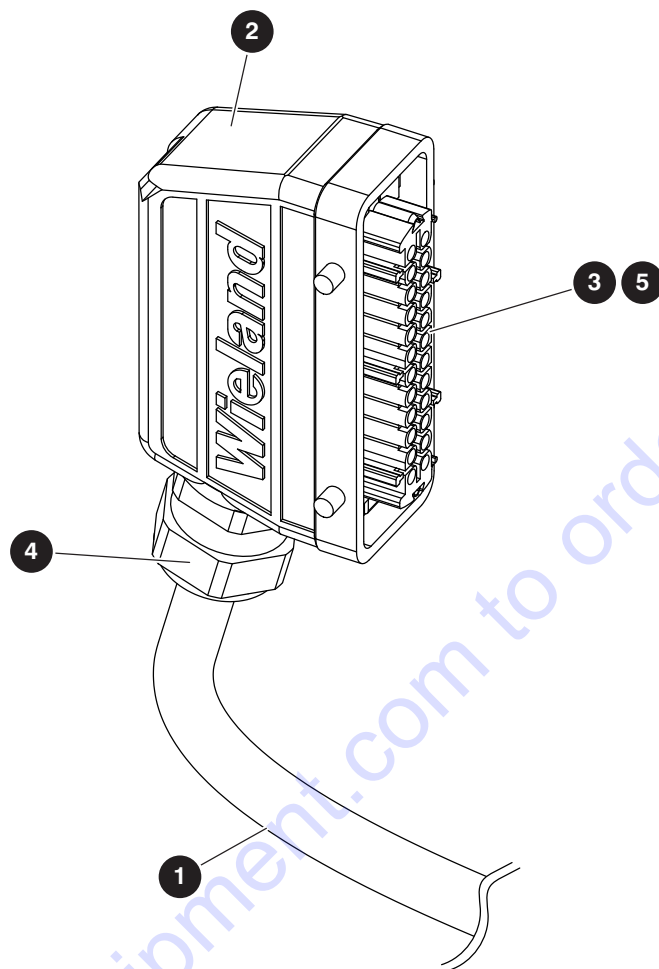

M192096AB

Index No.	Skyjack Part No.	Qty.	Description
-	192096	1	MOTOR CONTROLLER HARNESS "A"
1	192098	1	• CABLE, Cut - 16/25 (116")
2	138753	1	• HOOD, Side 24 pole M32
3	138756	1	• SOCKET, 24 pole spring 16A
4	138754	1	• RELIEF, Strain (M32 x 1.5)
5	121050	24	• CONNECTOR, Ferrule 16GA

5.3 Motor Controller Harness "B"

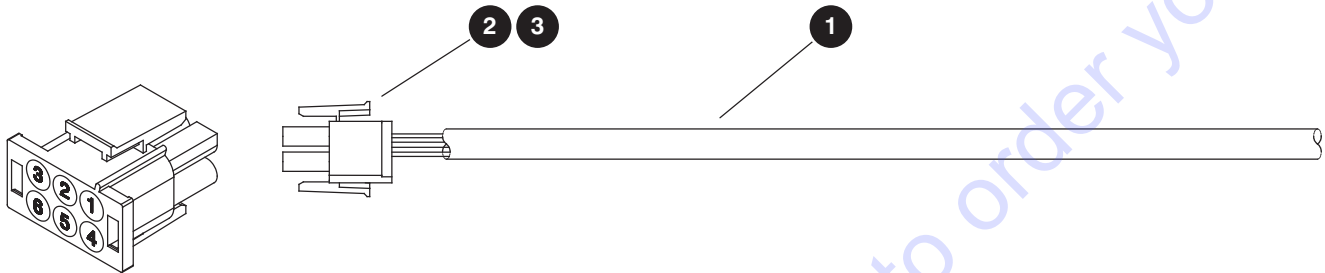

M207820AB

Index No.	Skyjack Part No.	Qty.	Description
-	207820	1	MOTOR CONTROLLER HARNESS "B"
1	192098	95"	<ul style="list-style-type: none"> CABLE, Control - 16/10
2	130445	1	<ul style="list-style-type: none"> PLUG, Male - 6 pole
3	116989	6	<ul style="list-style-type: none"> PIN, Wire - male

5.4 Main Manifold Harness

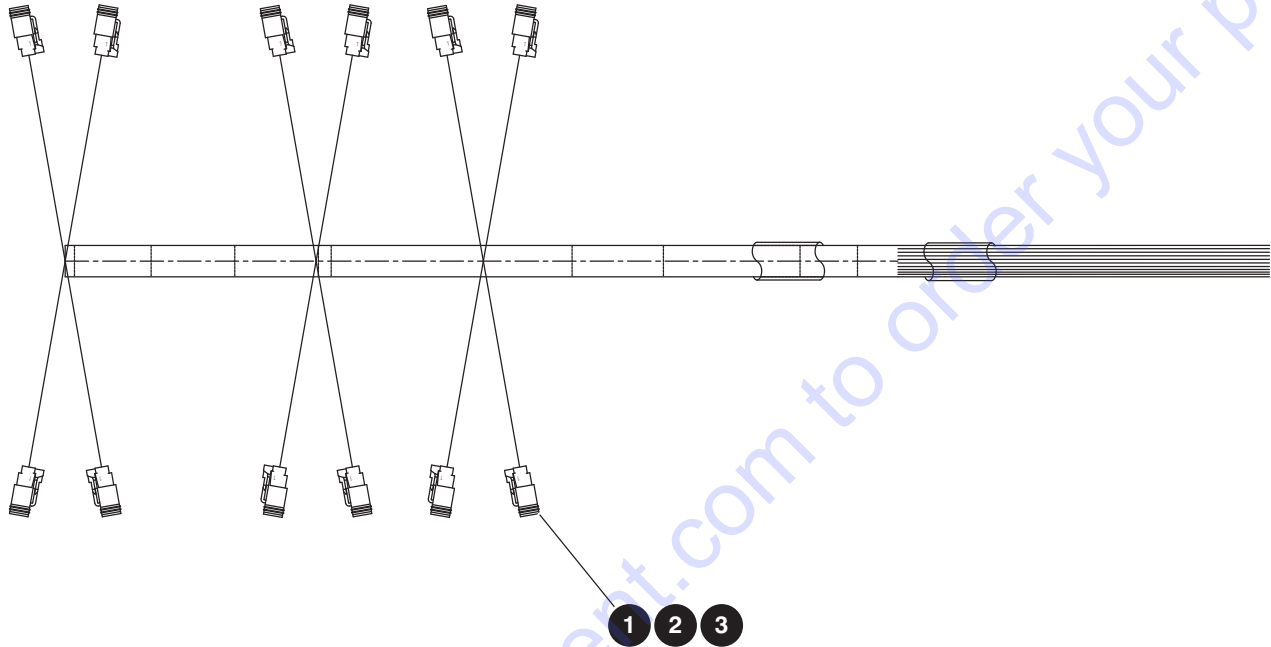

M192101AC

Index No.	Skyjack Part No.	Qty.	Description
A	192101	1	MAIN MANIFOLD HARNESS - ANSI/CSA, CE & AS
B	209042	1	MAIN MANIFOLD HARNESS - KC
1	117597	11	<ul style="list-style-type: none"> • PLUG, Deutsch - 2 pin
2	117591	22	<ul style="list-style-type: none"> • SOCKET, Deutsch - solid 16/18 GA
3	117599	11	<ul style="list-style-type: none"> • WEDGE, Deutsch - 2 pin

5.5 Steering Sensor Harness

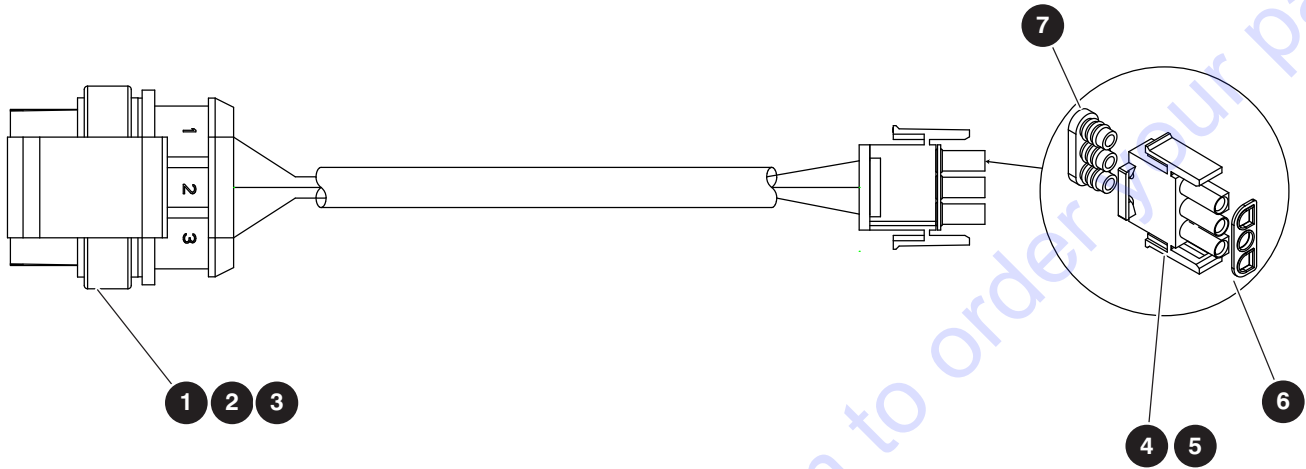

M192194AA

Index No.	Skyjack Part No.	Qty.	Description
-	192194	1	STEERING SENSOR HARNESS
1	192196	1	• CONNECTOR, AMP SUPERSEAL - 3-PIN
2	148471	3	• TERMINAL, AMP Superseal
3	148470	3	• SEAL, Cable - AMP Superseal
4	130446	1	• PLUG, Male - 3 pole
5	116989	3	• PIN, Male - wire
6	134067	1	• SEAL, Interface - 3 position
7	134068	1	• SEAL, 3 position

5.6 Charger Harness

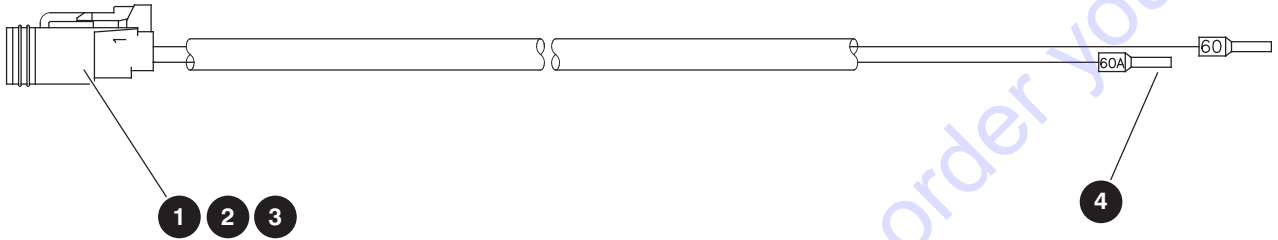

M192111AC

Index No.	Skyjack Part No.	Qty.	Description
-	192111	1	CHARGER HARNESS
1	117597	1	• PLUG, Deutsch - 2 pin
2	117599	1	• WEDGE, Deutsch - 2 pin
3	117591	2	• SOCKET, Deutsch - solid 16/18 GA
4	115401	2	• FERRULE, 18 GA red

5.7 Riser Cylinder Lowering Harness

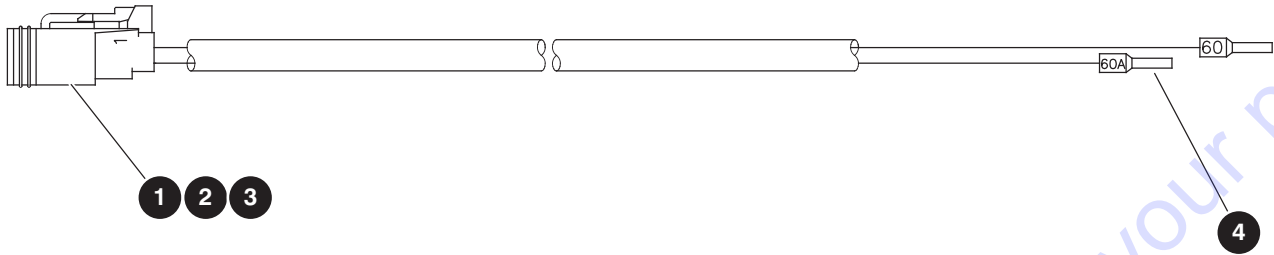

M192111AC

Index No.	Skyjack Part No.	Qty.	Description
-	192181	1	RISER CYLINDER LOWERING HARNESS
1	117597	1	• PLUG, Deutsch - 2 pin
2	117599	1	• WEDGE, Deutsch - 2 pin
3	117591	2	• SOCKET, Deutsch - solid 16/18 GA
4	115401	2	• FERRULE, 18 GA red

5.8 Anti - Overriding Posts Harness - KC

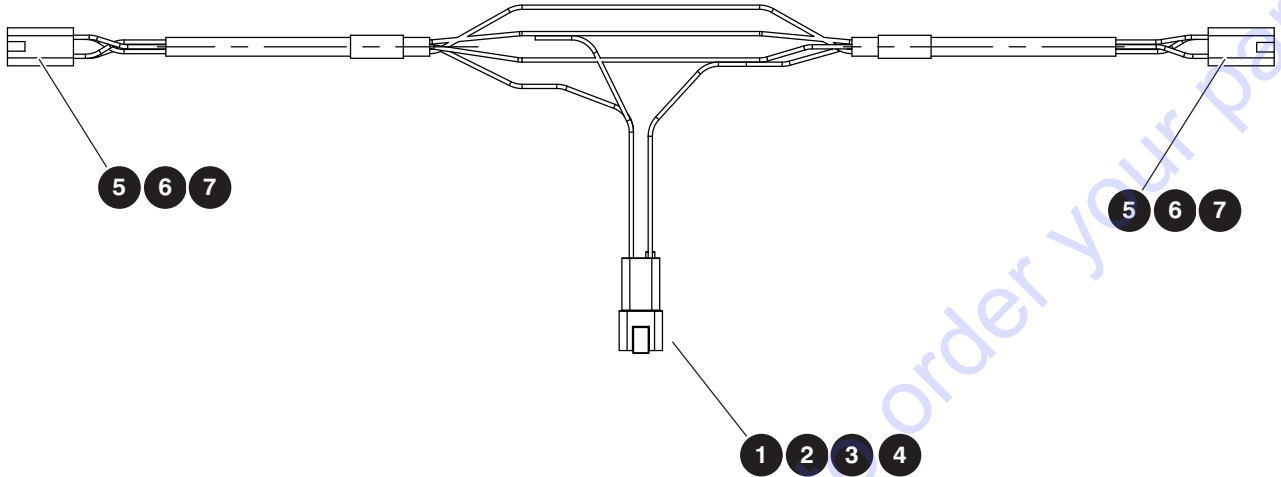

M207314AA

Index No.	Skyjack Part No.	Qty.	Description
-	207314	1	ANTI-OVERRISING POSTSPLATFORM LIMIT SWITCH HARNESS - KC
1	117578	1	• CONNECTOR, Receptacle (4 pin)
2	117580	1	• CONNECTOR, Receptacle (4 pin wedge)
3	117590	3	• CONNECTOR, Pin contact (16-18)
4	117594	1	• CONNECTOR, Sealing plug
5	117579	3	• CONNECTOR, Plug (4 pin)
6	117581	2	• CONNECTOR, Plug (4 pin wedge)
7	117591	8	• CONNECTOR, Contact socket (16-18)

5.9 Upper Control Harness - KC

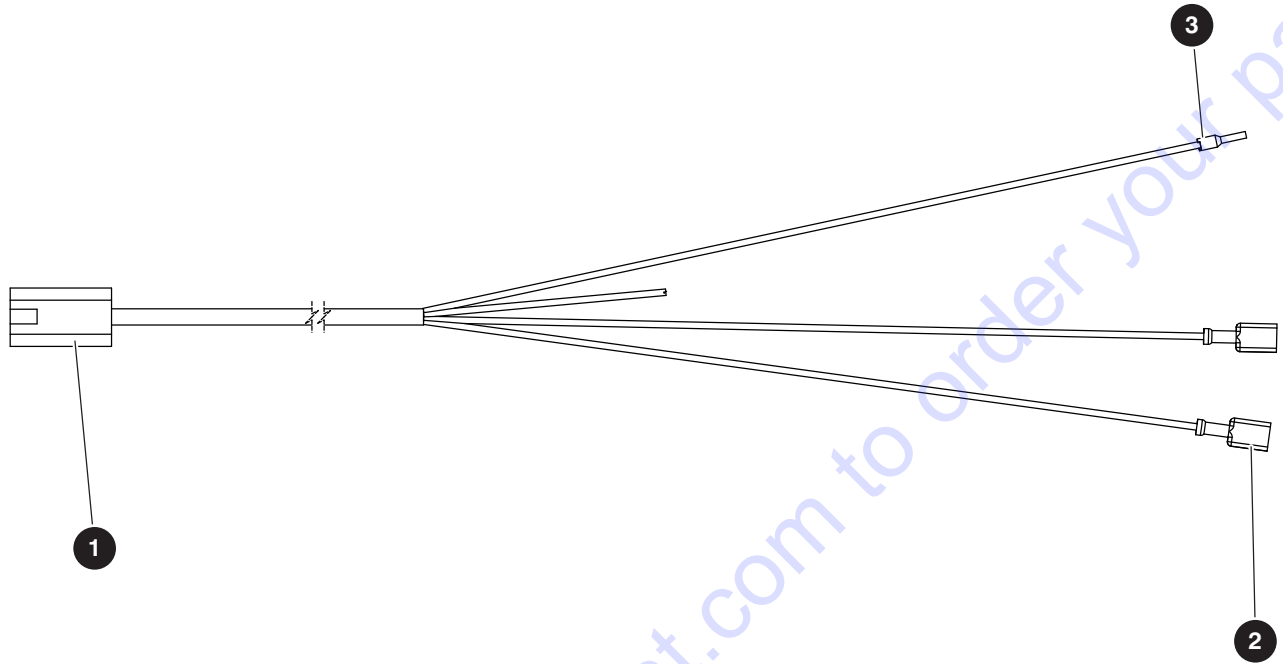

M208906AA

Index No.	Skyjack Part No.	Qty.	Description
-	208906	1	UPPER CONTROL HARNESS - KC
1	117579	1	• CONNECTOR, Plug - 4 pin
2	121050	1	• CONNECTOR, Ferrule (16 GA)
3	105359	2	• TERMINAL, Blade (0.25" 14-16 GA)

5.10 Lower Control Harness - KC

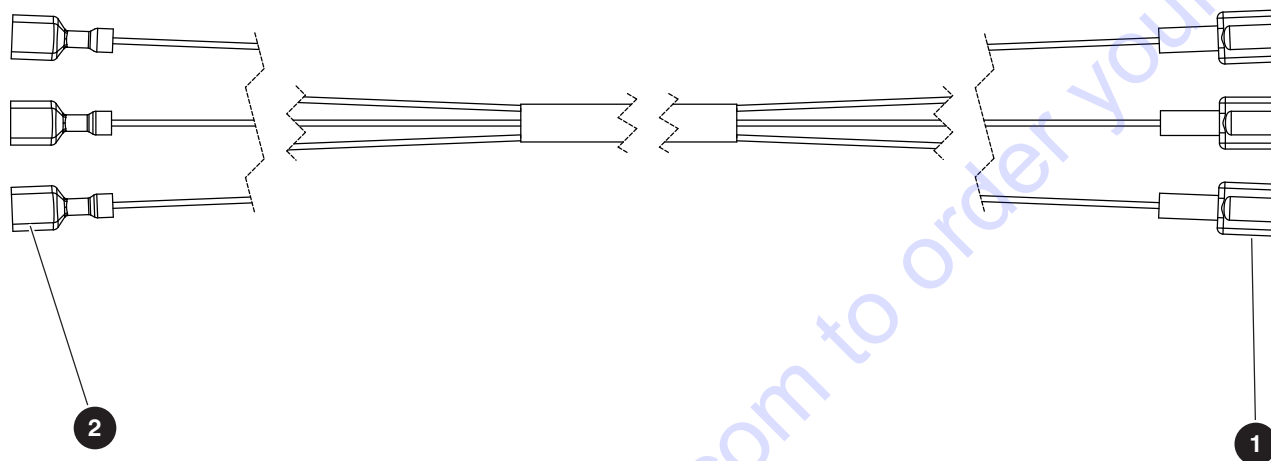

M209079AA

Index No.	Skyjack Part No.	Qty.	Description
-	209079	1	LOWER CONTROL HARNESS - KC
1	114594	3	<ul style="list-style-type: none"> • TERMINAL, Male (18-22 AWG)
2	114595	3	<ul style="list-style-type: none"> • TERMINAL, Female (18-22 AWG)

Section 6 – Base

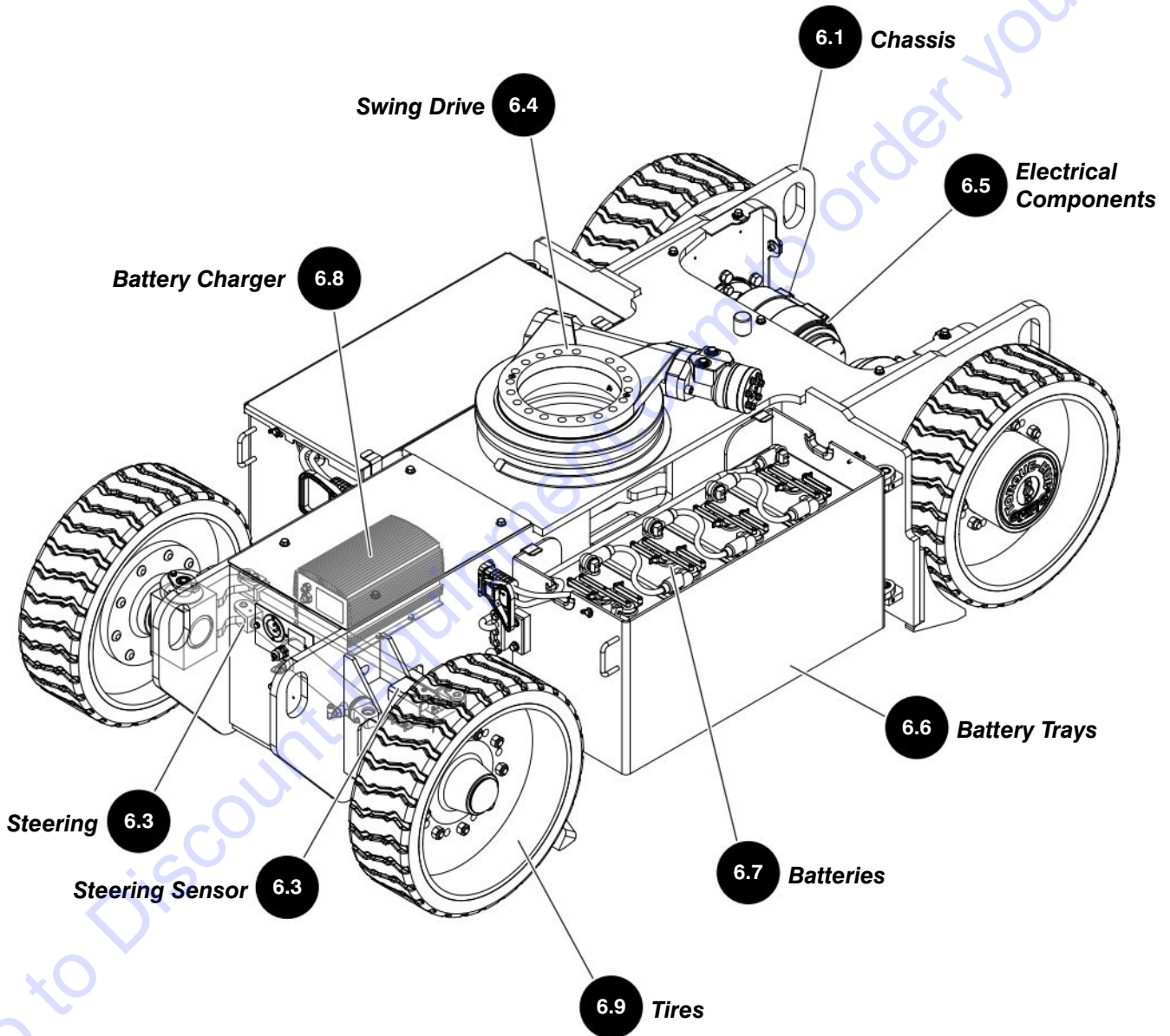

6.1 Chassis

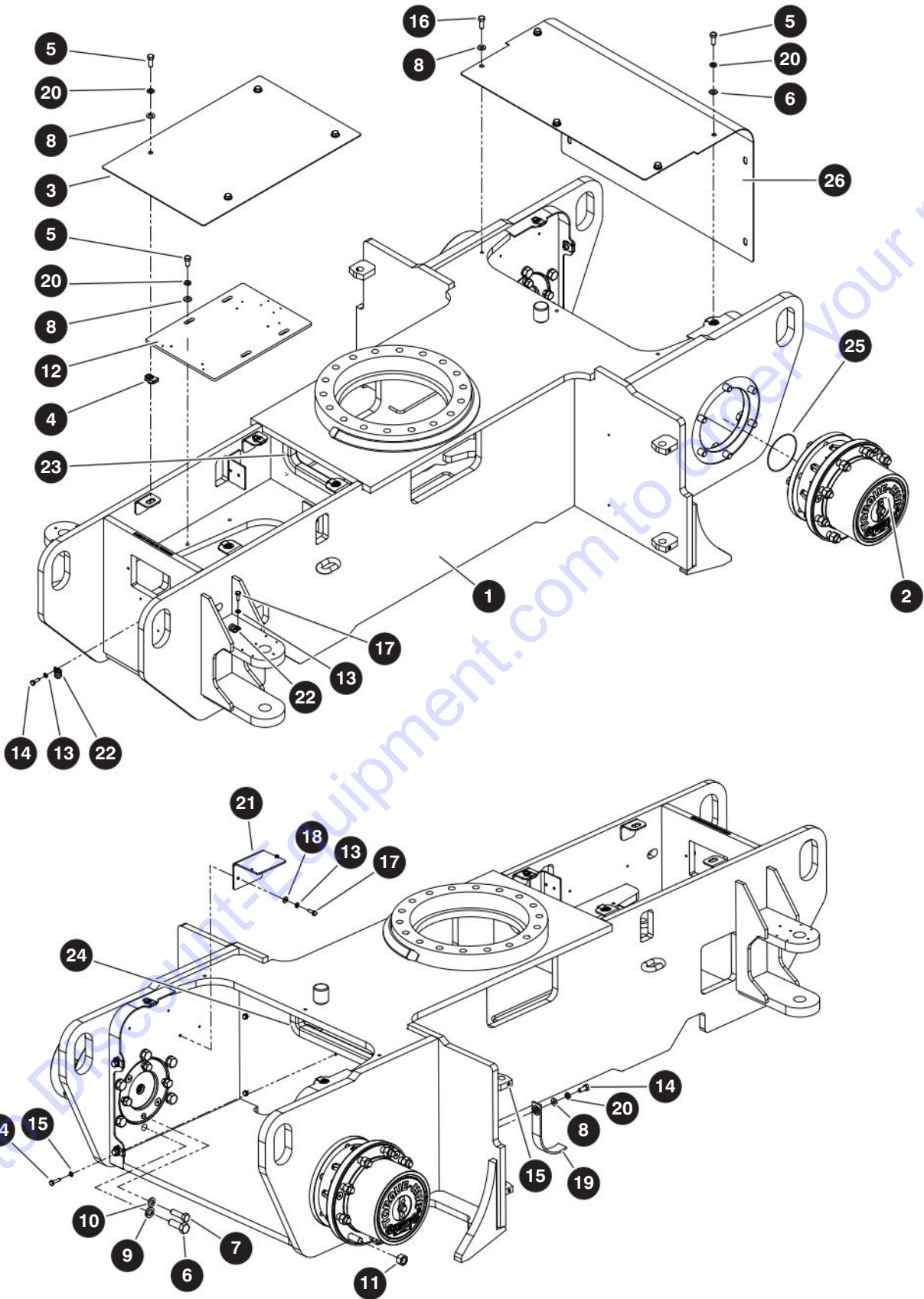

M192624AJ

229034ADA

SJ30 AJE, SJ30 ARJE

6.1 Chassis

Index No.	Skyjack Part No.	Qty.	Description
-	192624	1	CHASSIS ASSEMBLY
1	192301	1	• CHASSIS WELDMENT
2	192202	2	• HUB, Torque
	209458	1	• • SEAL KIT
	209459	1	• • BEARING KIT
	209460	1	• • INPUT PLANET KIT*
	209461	1	• • SPINDLE PLANET KIT*
	209462	1	• • OUTPUT PLANET KIT*
	209463	1	• • COVER KIT
3	192607	1	• PLATE, Cover
4	195294	10	• NUT, Speed clip (0.375"-16)
5	103473	14	• BOLT, Hex head (0.375"-16 x 1.00" gr 5)
6	192612	12	• BOLT, Hex head (0.625"-11 x 1.75" gr 5)
7	126361	8	• BOLT, Hex head (0.50"-13 x 1.75" gr 8)
8	103472	18	• WASHER, Flat (0.375" SAE)
9	103998	12	• WASHER, Lock (0.625")
10	104379	8	• WASHER, Flat (0.50" hard)
11	103315	18	• NUT, Wheel (0.625"-15)
12	221725	1	• PLATE, Charger mount
13	104000	4	• WASHER, Lock (0.25")
14	300437	1	• BOLT, Hex head (0.375"-16 x 0.875" gr 5)
15	104625	4	• SCREW, Set cup (0.375"-16 x 0.625")
16	101632	3	• BOLT, Hex head (0.375"-16 x 0.75" gr 5)w
17	103856	4	• BOLT, Hex head (0.25"-20 x 0.75" gr 5)
18	103995	5	• WASHER, Flat (0.25" SAE)
19	115420	1	• STRAP, Static
20	103999	18	• WASHER, Lock (0.75")
21	192697	1	• BRACKET, Tilt switch mount
22	103024	2	• CLAMP, Single clip (G8)
23	162053	13.25"	• TRIM, Protective (0.75")
24	162053	20"	• TRIM, Protective (0.75")
25	211116	2	• SEAL, O-Ring (0.070 x 3.989 ID, -045)
26	192348	1	PLATE, Cover - rear *Also order a seal kit when replacing these components

6.2 Steering

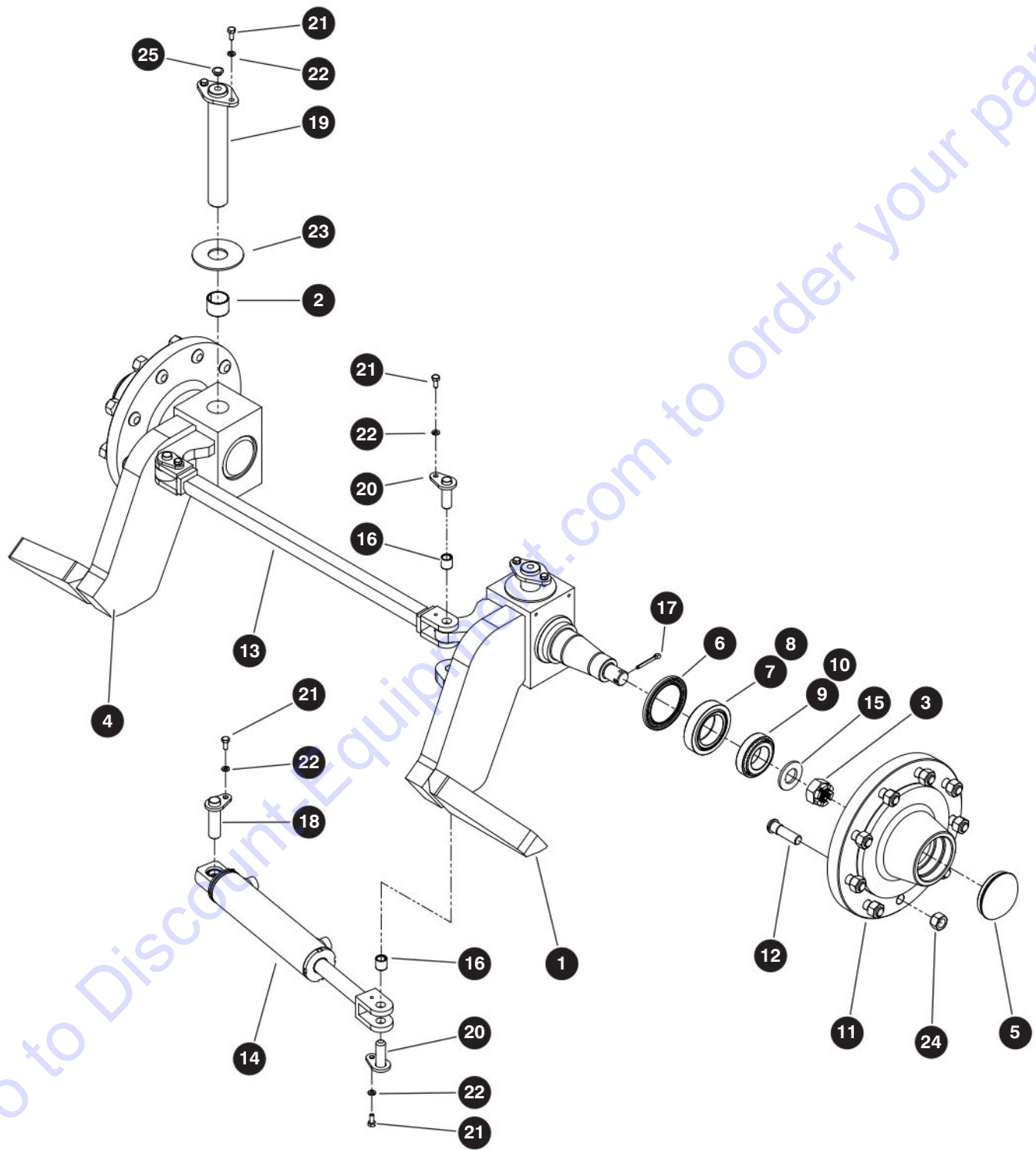

M192306AH

229034ADA

126

SJ30 AJE, SJ30 ARJE

SKYJACK

6.2 Steering

Index No.	Skyjack Part No.	Qty.	Description
-	192306	1	STEERING ASSEMBLY
1	221883	1	• KNUCKLE, Steer - right
2	148847	4	• BEARING, Bushing (1.25" IS x 1.00" lg)
3	192386	2	• NUT, Hex slotted (1.00"-14 UNF)
4	221884	1	• KNUCKLE, Steer - left
-	192201	2	• HUB, Free spinning
5	207246	1	• • COVER, Hub
6	207247	1	• • SEAL, Knuckle
7	207248	1	• • BEARING, Inner cone
8	209369	1	• • BEARING, Inner cup/race
9	207249	1	• • BEARING, Outer cone
10	209370	1	• • BEARING, Outer cup/race
11	207250	1	• • HUB
12	207258	9	• • STUD, Wheel (0.625")
13	192384	1	• ROD, Tie (25.50" lh)
14	192078	1	• CYLINDER, Steering (For components, refer to 3.7 Steering Cylinder)
15	102646	2	• WASHER, Hardened (1.00")
16	192387	3	• BUSHING, Fiberglide (0.625" dia x 1.5")
17	192601	2	• PIN, Cotter (0.188" dia x 1.50")
18	192389	1	• PIN (0.75" dia x 2.63" lg)
19	192366	2	• PIN, King (1.25" dia x 8.75" lg)
20	192394	3	• PIN (0.625" dia x 2.00" lg)
21	103892	8	• BOLT, Hex head (0.25"-20 x 0.625" gr 5)
22	104000	8	• WASHER, Lock (0.25")
23	207253	2	• WASHER, Thrust - FTP (2.00" OD x 1.25" ID)
24	103315	18	• NUT, Wheel (0.625"-15 0.626" 90° angle)
25	192765	2	• PLUG, LDPE (0.50")

6.3 Steering Sensor

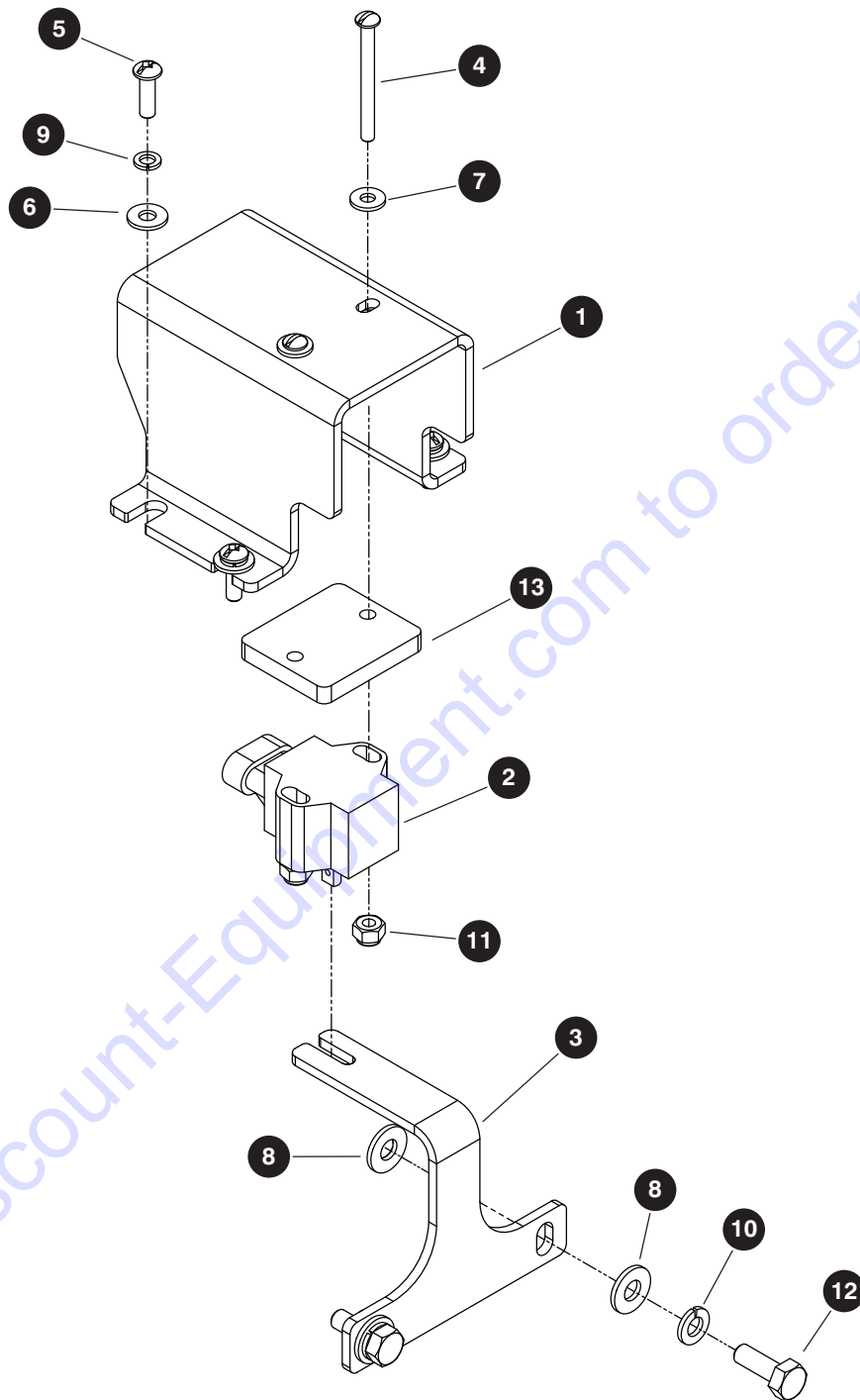

M192636AC

229034ADA

128

SJ30 AJE, SJ30 ARJE

SKYJACK

6.3 Steering Sensor

Index No.	Skyjack Part No.	Qty.	Description
-	192636	1	STEERING SENSOR ASSEMBLY
1	192809	1	• COVER, Steering sensor
2	192173	1	• SENSOR, Rotary position (270)
3	192172	1	• LEVER, Steering sensor
4	192815	2	• SCREW, Round head machine (8-32 x 1.75" SS)
5	120094	4	• SCREW, Round head machine (10-32 x 0.625" SS)
6	104694	4	• WASHER, Flat (#10)
7	207241	2	• WASHER, Flat (#8 SAE SS)
8	103995	4	• WASHER, Flat (0.25" SAE)
9	104185	4	• WASHER, Lock (#10)
10	104000	2	• WASHER, Lock (0.25")
11	207240	2	• NUT, Lock (8-32 gr 5 SS nylon)
12	103856	2	• BOLT, Hex head (0.25"20 x 0.75" gr 5)
13	192812	1	• SPACER
14	192194	1	• HARNESS, Steering sensor (not shown) (For components, refer to 5.5 Steering Sensor Harness)

6.4 Swing Drive

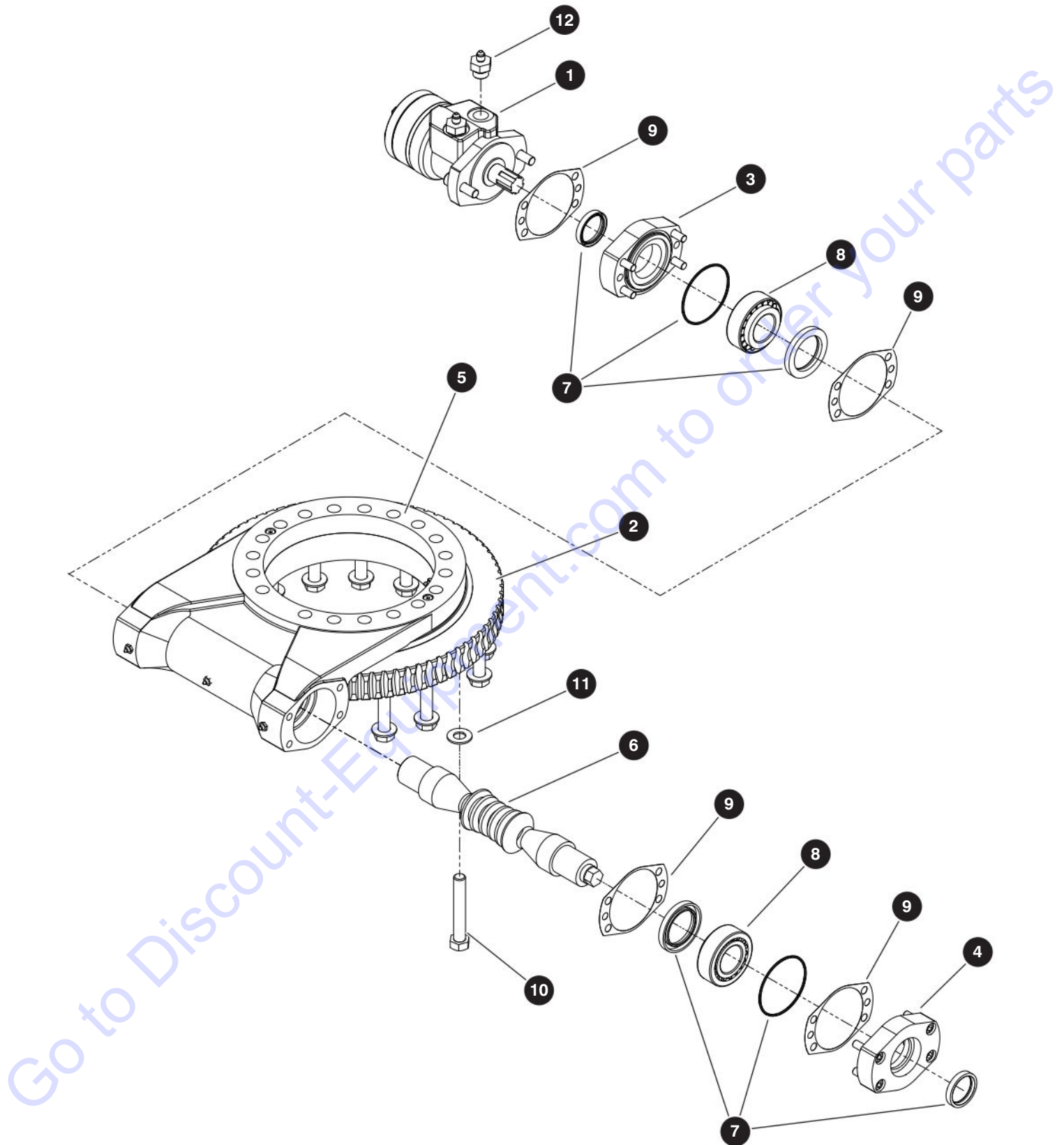

M192626AD

229034ADA

130

SJ30 AJE, SJ30 ARJE

SKYJACK

6.4 Swing Drive

Index No.	Skyjack Part No.	Qty.	Description
-	192626	1	SWING DRIVE ASSEMBLY
-	192206	1	• SWING DRIVE WITH MOTOR
1	207350	1	• • MOTOR ASSEMBLY
2	207351	1	• • SLEW BEARING ASSEMBLY
3	207352	1	• • END CAP, Motor side
4	209195	1	• • END CAP
5	207353	1	• • HOUSING ASSEMBLY
6	207354	1	• • SHAFT
7	207355	1	• • SEAL KIT
8	207356	1	• • BEARING KIT
9	207357	1	• • SHIM KIT
10	192219	18	• BOLT, Hex head (0.625"-11 x 4.00" gr 8)
11	700782	18	• WASHER, Flat (0.625" hardened)
12	192195	2	• FITTING, Straight (04 JICM - 10 ORBM)

6.5 Electrical Components

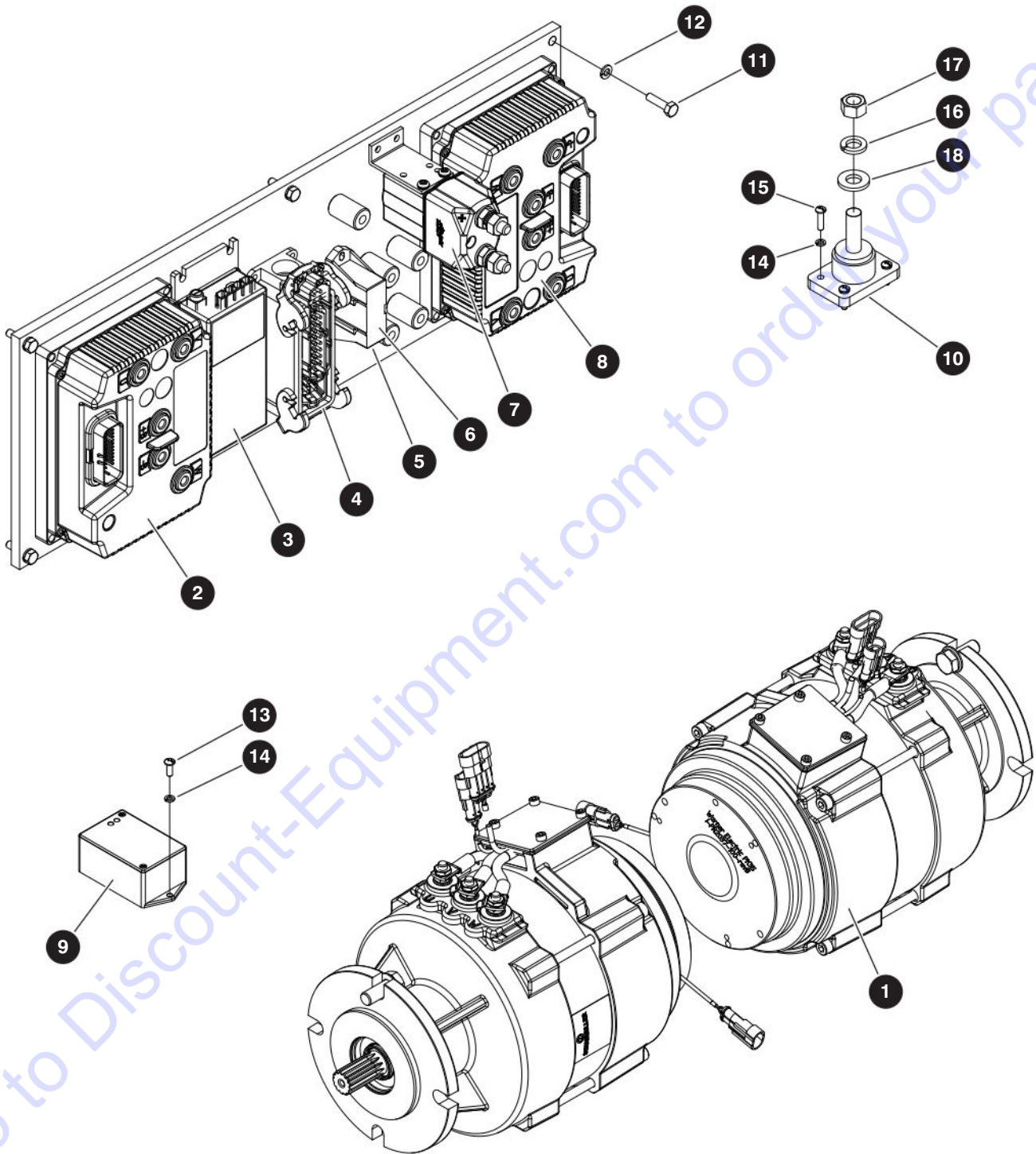

M192309AG

229034ADA

132

SJ30 AJE, SJ30 ARJE

SKYJACK

6.5 Electrical Components

Index No.	Skyjack Part No.	Qty.	Description
-	192309	1	ELECTRICAL ASSEMBLY
1	192066	2	• MOTOR, Electric with brake
-	221980	1	• PANEL, Motor controller
2	207406	1	• • CONTROLLER, ACE0 inverter
3	207405	1	• • CONVERTER, DC-DC
4	207409	1	• • HARNESS, Motor controller panel
5	207407	1	• • HOLDER, Fuse
6	207408	1	• • FUSE, Power - 350A
7	207404	1	• • CONTACTOR, Safety line
8	207403	1	• • CONTROLLER, Combi AC0 inverter
9	192190	1	• SWITCH, Tilt (25° analog)
10	192182	1	• STUD, Battery - isolated
11	103856	6	• BOLT, Hex head (0.25"-20 x 0.75" gr 5)
12	104000	6	• WASHER, Lock (0.25")
13	103960	2	• SCREW, Round head machine (10-24 x 0.50")
14	104185	6	• WASHER, Lock (#10)
15	138834	4	• SCREW, Round head machine (10-24 x 0.75")
16	103470	1	• WASHER, Lock (0.50" gr 5)
17	103471	1	• NUT, Hex (0.50"-13 gr 5)
18	104379	1	• WASHER, Flat (0.50" SAE hardened)
19	210199	1	CABLE, Adapter - CANBUS to IXXAT (5 ft) - for Service (not shown)
	212917	1	CABLE, Adapter - CANBUS to IXXAT (20 ft) - for Service (not shown)

6.6 Battery Trays

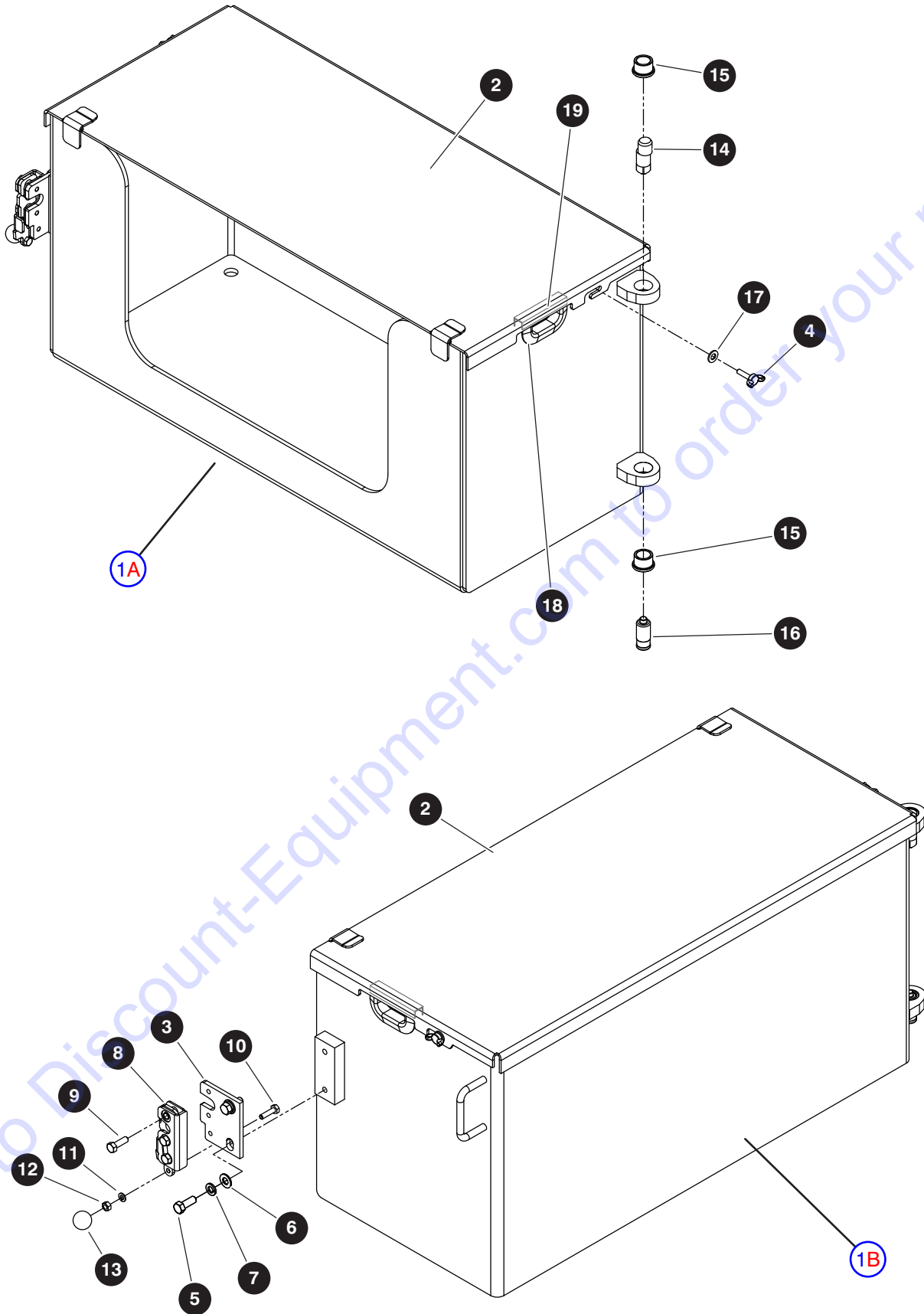

M192302AJ_M195305AJ

229034ADA

134

SJ30 AJE, SJ30 ARJE

SKYJACK

6.6 Battery Trays

Index No.	Skyjack Part No.	Qty.	Description
A	192302	1	BATTERY TRAY - RIGHT
B	192305	1	BATTERY TRAY - LEFT
1	192303	1	• WELDMENT, Battery tray - right, A
	192307	1	• WELDMENT, Battery tray - left, B
2	192600	1	• COVER, Battery tray
3	192358	1	• PLATE, Latch slotted
4	207242	2	• SCREW, Wing (0.25"-20 x 1.00")
5	103473	2	• BOLT, Hex head (0.375"-16 x 1.00" gr 5)
6	103472	2	• WASHER, Flat (0.375" SAE)
7	103999	2	• WASHER, Lock (0.375")
8	112308	1	• LATCH, Rotary (RH)
9	103864	3	• BOLT, Hex head (0.312"-18 x 1.00" gr 5)
10	103857	1	• BOLT, Hex head (0.25"-20 x 1.00" gr 5)
11	104000	1	• WASHER, Lock (0.25")
12	103980	1	• NUT, Hex head (0.25"-20 gr 8)
13	111534	1	• KNOB, Black (1" dia x 0.25"-20)
14	100446	1	• PIN, Eccentric - short (0.125" offset)
15	100335	2	• BUSHING, Bronze
16	118983	1	• PIN, Tray - lower
17	103996	2	• WASHER, Flat (0.312" SAE)
18	119922	12.5"	• TRIM, Protective (0.25" - 0.50")
19	117398	8"	• TRIM, Protective (0.1875" - 0.25")

6.7 Batteries

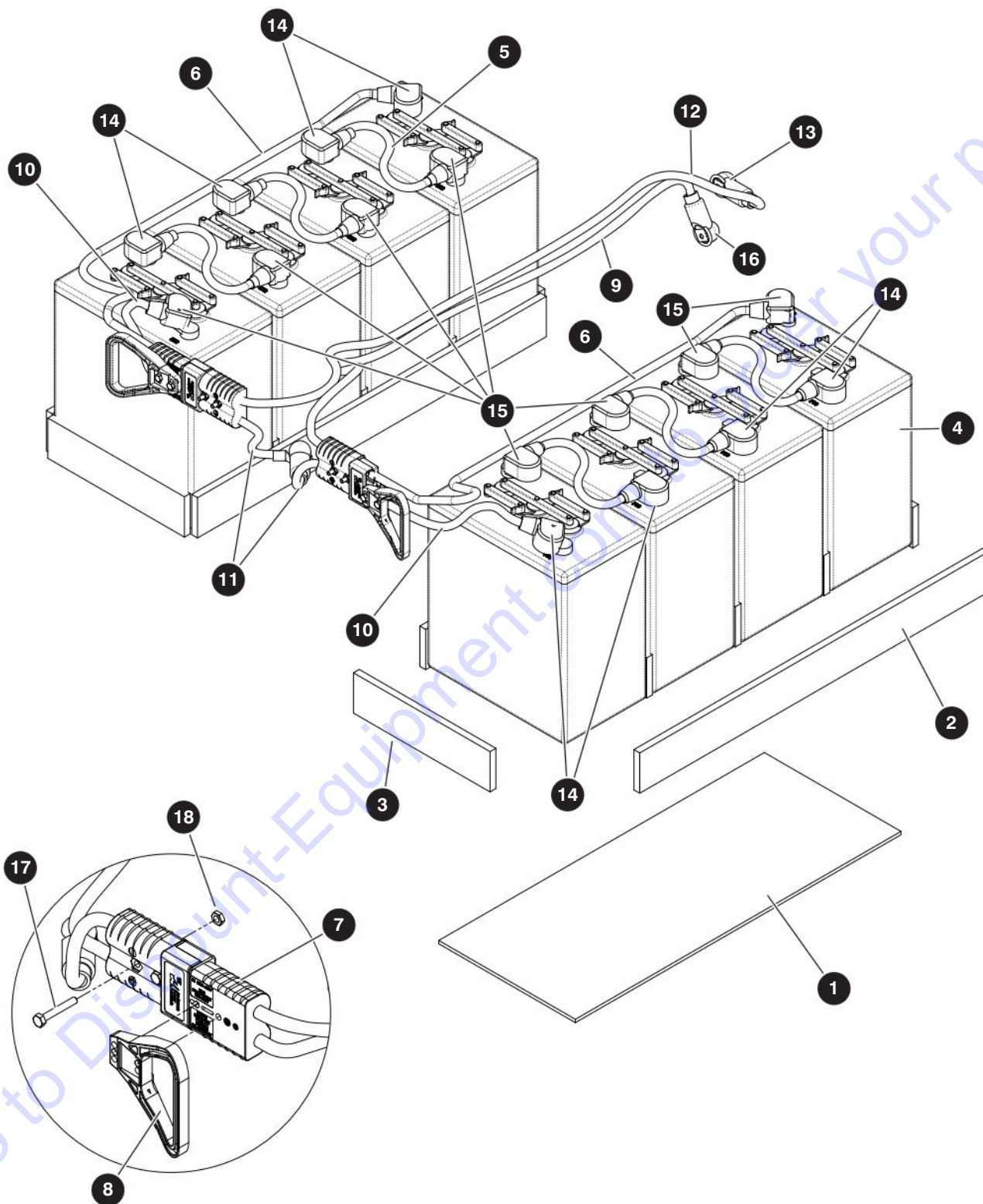

M192760AE

229034ADA

136

SJ30 AJE, SJ30 ARJE

SKYJACK

6.7 Batteries

Index No.	Skyjack Part No.	Qty.	Description
A	192760	1	BATTERY ASSEMBLY - 305 AH - ANSI/CSA, CE & KC - Standard
B	192790	1	BATTERY ASSEMBLY - 360 AH - ANSI/CSA, CE & KC - Optional
C	192780	1	BATTERY ASSEMBLY - AGM - ANSI/CSA, CE & KC - Optional
D	192770	1	BATTERY ASSEMBLY - 305 AH - AS - Standard
E	192810	1	BATTERY ASSEMBLY - 360 AH - AS - Optional
F	192690	1	BATTERY ASSEMBLY - AGM - AS - Optional
-	192761	1	• BATTERY SPACER ASSEMBLY, A, B, C
	192771	1	• BATTERY SPACER ASSEMBLY, D, E, F
1	192614	2	• • SPACER, Plywood (0.25" x 29.5" x 11.75"), A, B, C
	192775	2	• • SPACER, Plastic (0.25" x 29.5" x 11.75"), D, E, F
2	192616	4	• • SPACER, Plywood (0.50" x 30.0" x 3.0"), A, B, C
	192774	4	• • SPACER, Plastic (0.50" x 30.0" x 3.0"), D, E, F
3	192617	10	• • SPACER, Plywood (0.50" x 11.75" x 3.0"), A, B, C
	192773	10	• • SPACER, Plastic (0.50" x 11.75" x 3.0"), D, E, F
-	192762	1	• BATTERY ASSEMBLY, 305AH, A, D
	192791	1	• BATTERY ASSEMBLY, 385AH, B, E
	192781	1	• BATTERY ASSEMBLY, AGM, C, F
4	701048	8	• • BATTERY, 305AH, A, D
	140427	8	• • BATTERY, 385AH, B, E
	166514	8	• • BATTERY, 390AH AGM, C, F
			Continued on the next page.

6.7 Batteries

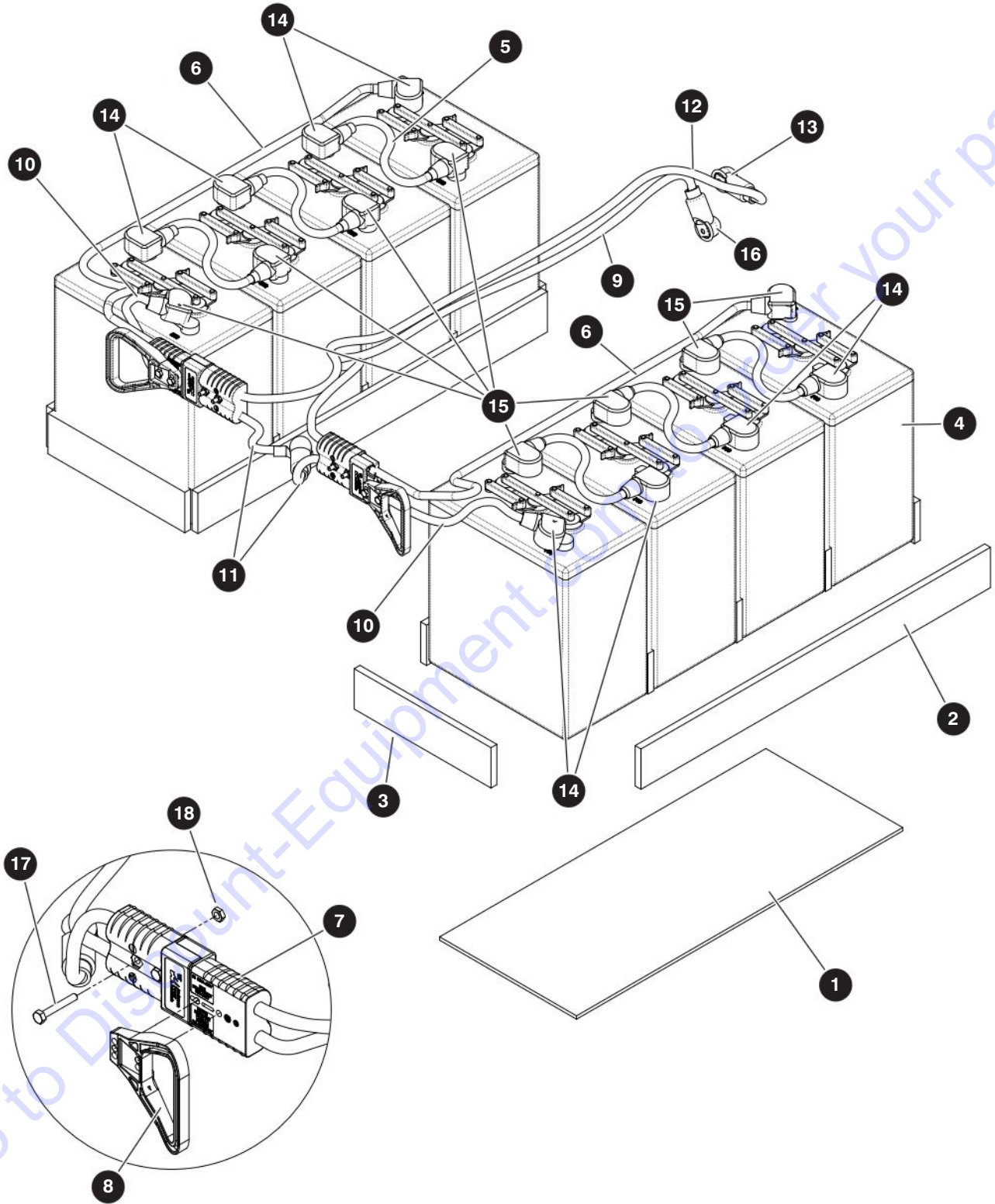

M192760AE

229034ADA

SJ30 AJE, SJ30 ARJE

6.7 Batteries

Index No.	Skyjack Part No.	Qty.	Description
			<i>Continued from the previous page.</i>
-	192764	1	• BATTERY CABLE ASSEMBLY, A, B, D, E
	192332	1	• BATTERY CABLE ASSEMBLY, C, F
5	192113	6	• • CABLE, Welding (1GA 0.3125" x 12.0" x 0.3125" (-,+))
6	192116	2	• • CABLE, Welding (#2/0 contact x 42" x 0.3125"), A, B, D, E
	210431	2	• • CABLE, Welding (#2/0 contact x 42" x 0.3125"), C, F
7	192120	4	• • HOUSING, Battery connector
8	119829	2	• • HANDLE, Battery disconnect - red
9	192114	1	• • CABLE, Welding (#2/0 contact x 55" x 0.3125" (-,-))
10	192117	2	• • CABLE, Welding (#2/0 contact x 15" x 0.3125" (-,-))
	210432	2	• • CABLE, Welding (#2/0 contact x 15" x 0.3125" (-,-))
11	192119	2	• • CABLE, Welding (#2/0 contact x 10" x contact (-,+))
12	192122	2	• • CABLE, Welding (#2/0 contact x 55" x 0.375" (-,-))
13	139105	1	• • BOOT, Terminal - #2/0 red (5737-005R)
14	209605	8	• • INSULATOR, Boot (red), A, B, D, E
	139105	8	• • INSULATOR, Boot (red), C, F
15	209606	8	• • INSULATOR, Boot (black), A, B, D, E
	207306	8	• • INSULATOR, Boot (black), C, F
16	207306	1	• • INSULATOR, Boot (black)
17	103860	8	• • BOLT, Hex head (0.25"-20 x 1.75" gr 5)
18	192910	4	• • NUT, Hex wide (0.25"-20 gr 5)

6.8 Battery Charger

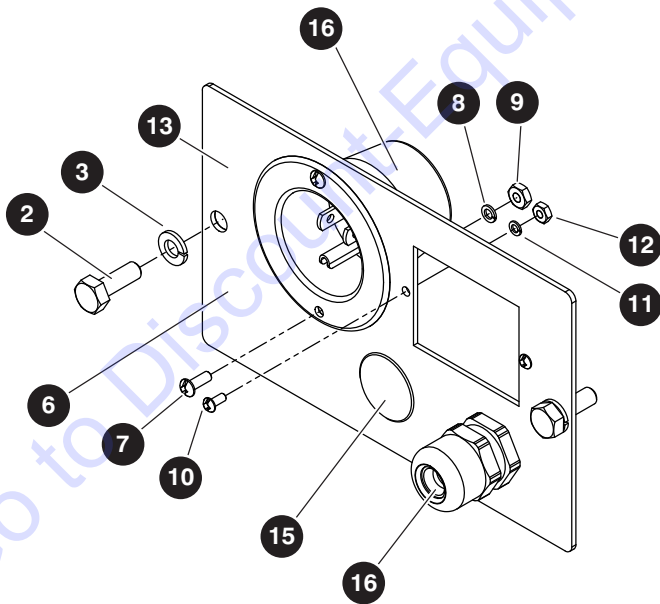
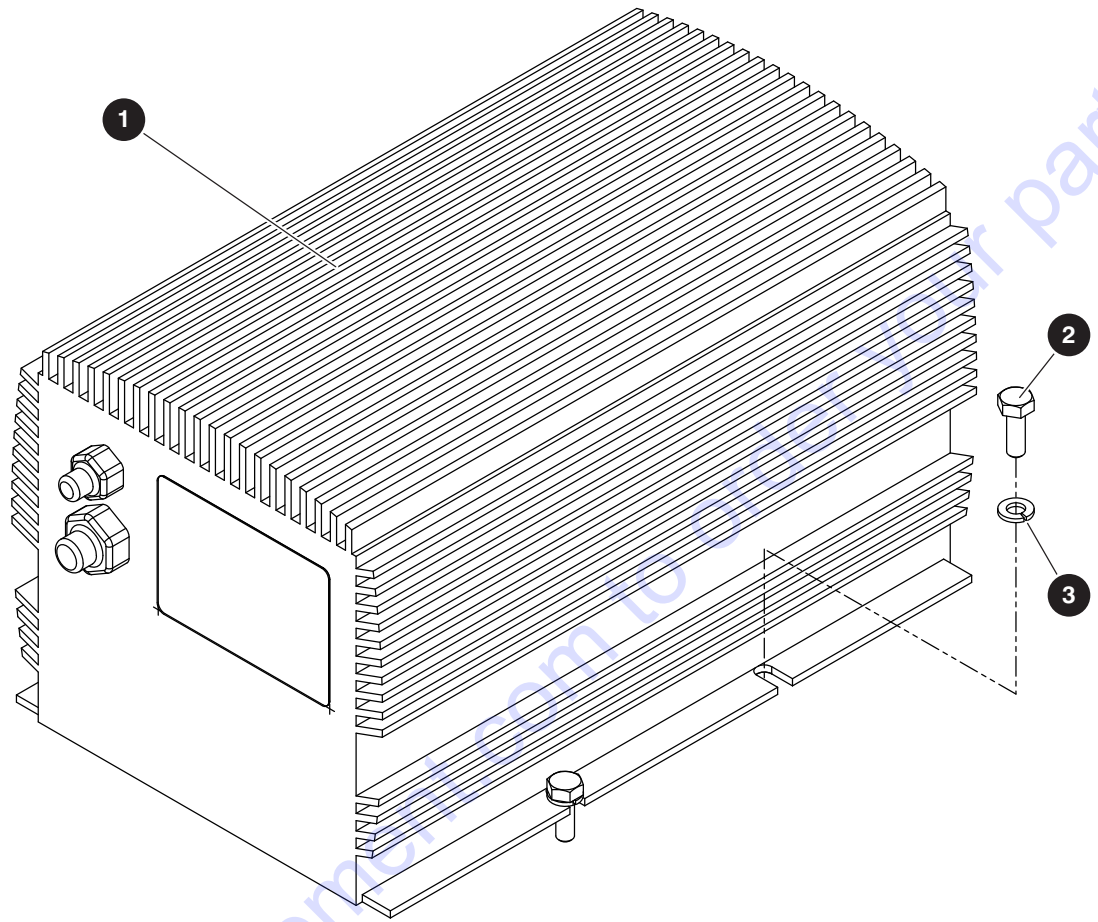

M192581AD

229034ADA

140

SJ30 AJE, SJ30 ARJE

SKYJACK

6.8 Battery Charger

Index No.	Skyjack Part No.	Qty.	Description
A	192581	1	BATTERY CHARGER - SIGNET - Standard - ANSI/CSA
B	210306	1	BATTERY CHARGER - SIGNET - Standard - CE, AS & KC
1	192193	1	• CHARGER, Battery - Signet 1.5 kW, A
	210379	1	• CHARGER, Battery - Signet 1.5 kW, B
2	103856	6	• BOLT, Hex head (0.25"-20 x 0.75" gr 5)
3	104000	6	• WASHER, Lock (0.25")
4	103995	4	• WASHER, Flat (0.25" SAE)
5	192111	1	• HARNESS, 2 pole connector (not shown)
6	105271	1	• INLET, 110V connector
7	121461	2	• SCREW, Round head machine (6-32 x 0.375")
8	106099	2	• WASHER, Lock (#6)
9	103985	2	• NUT, Hex (6-32)
10	121461	2	• SCREW, Round head machine (6-32 x 0.375")
11	116068	2	• WASHER, Lock (#4)
12	116067	2	• NUT, Hex (4-40)
13	192364	1	• PLATE, Adapter - charger
14	103036	1	• RELIEF, Strain (0.05" NPT)
15	102956	1	• PLUG, Snap-in for 0.875" hole)
16	113227	1	• COVER, Seal tite, A

6.9 Tires

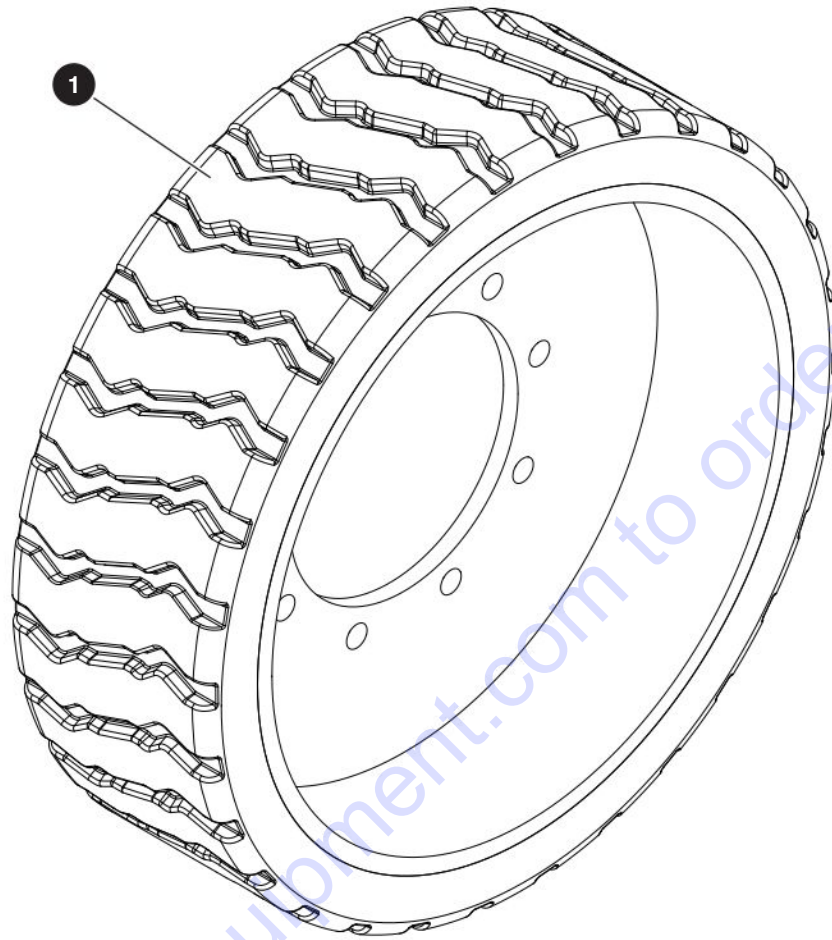

M192203AC

Index No.	Skyjack Part No.	Qty.	Description
A	192628	1	TIRE ASSEMBLY (7.0)
1	192203	4	<ul style="list-style-type: none"> TIRE, 22 x 7 - 9 bolt

Section 7 – Hose Connections

7.1 *Standard Hose Numbering System*

7.2 *Hydraulic Hoses - Base*

7.3 *Hydraulic Hoses - Turret*

7.4 *Hydraulic Hoses - Boom*

7.5 *Hydraulic Hoses - Jib*

7.1 Standard Hose Numbering System

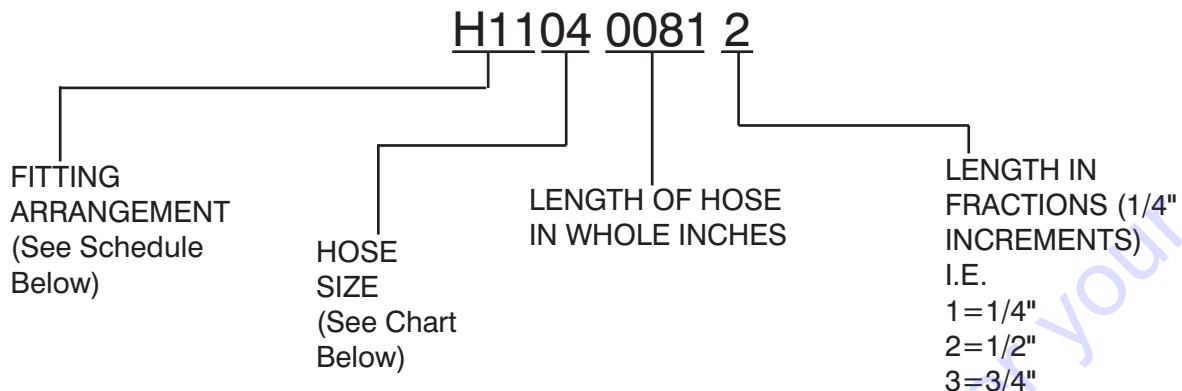

Using the number above as an example (H1104 0081 2). This hose requires a 37° JIC, female swivel fitting on one end. A medium length 90° JIC, female swivel fitting for the other end. The Hose must meet or exceed S.A.E. 100R13 hose specification, and be a total of 81-1/2" long.



NOTE

Hose ends and hose must be from same manufacturer per S.A.E. J1273 Nov. '91, Sections 3.10 and 4.2. Hose ends and hose must be of the same size i.e. #4 size fittings must be used with #4 size hose.

Hole Size Chart

Size	03	04	06	08	10	12	16	20	24	32	40	48	56	64
ID	3/16"	1/4"	3/8"	1/2"	5/8"	3/4"	1"	1-1/4"	1-1/2"	2"	2-1/2"	3"	3-1/2"	4"

Fitting Arrangement Schedule

Hose Prefix	Hose End Fitting	Hose End Fitting	S.A.E. Hose Specification
H01	FEMALE, 37° JIC, SWIVEL	FEMALE, 37° JIC, SWIVEL	100R17
H02	FEMALE, 37° JIC, SWIVEL	FEMALE, 37° JIC, SWIVEL	100R13
H03	FEMALE, 37° JIC, SWIVEL	45°, FEMALE, 37° JIC, SWIVEL	100R17
H04	FEMALE, 37° JIC, SWIVEL	45°, FEMALE, 37° JIC, SWIVEL	100R13
H05	FEMALE, 37° JIC, SWIVEL	LONG 90°, FEMALE, 37° JIC, SWIVEL	100R17
H06	FEMALE, 37° JIC, SWIVEL	SHORT 90°, FEMALE, 37° JIC, SWIVEL	100R17
H07	LONG 90°, FEMALE, 37° JIC, SWIVEL	LONG 90°, FEMALE, 37° JIC, SWIVEL	100R17
H08	FEMALE, 37° JIC, SWIVEL	FEMALE, 37° JIC, SWIVEL	100R4
H09	FEMALE, 37° JIC, SWIVEL	45°, FEMALE, 37° JIC, SWIVEL	100R4
H10	FEMALE, 37° JIC, SWIVEL	MALE PIPE THREAD FITTING	100R17
H11	FEMALE, 37° JIC, SWIVEL	MEDIUM 90°, FEMALE, 37° JIC, SWIVEL	100R13
H12	SHORT 90°, FEMALE, 37° JIC, SWIVEL	SHORT 90°, FEMALE, 37° JIC, SWIVEL	100R17
H13	FEMALE, 37° JIC, SWIVEL	REUSABLE MALE PIPE THREAD FITTING	300 PSI
H14	REUSABLE MALE PIPE THREAD FITTING	NO FITTING	300 PSI
H15	REUSABLE FEMALE, 37° JIC, SWIVEL	REUSABLE FEMALE, 37° JIC, SWIVEL	300 PSI
H16	NO FITTING	NO FITTING	100R4
H17	NO FITTING	NO FITTING	300 PSI
H18	REUSABLE, FEMALE, 37° JIC, SWIVEL	NO FITTING	300 PSI

7.1 Standard Hose Numbering System

Hose Prefix	Hose End Fitting	Hose End Fitting	S.A.E. Hose Specification
H19	LONG 90°, FEMALE, 37° JIC, SWIVEL	FEMALE, 37° JIC, SWIVEL	100R13
H20	FEMALE, SHORT 37° JIC, SWIVEL	SHORT 90°, FEMALE, 37° JIC, SWIVEL	100R4
H21	FEMALE, SHORT 37° JIC, SWIVEL	SHORT 90°, FEMALE, 37° JIC, SWIVEL	100R2AT
H22	FEMALE, 37° JIC, SWIVEL	FEMALE, 37° JIC, SWIVEL	100R2AT
H23	FEMALE, LONG 37° JIC, SWIVEL	LONG 90°, FEMALE, 37° JIC, SWIVEL	100R2AT
H24	FEMALE, SHORT 37° JIC, SWIVEL	SHORT 90°, FEMALE, 37° JIC, SWIVEL	100R13
H25	FEMALE, 37° JIC, SWIVEL	FEMALE, 37° JIC, SWIVEL	100R4
H30	MEDIUM 90°, FEMALE, 37° JIC, SWIVEL	FEMALE, 37° JIC, SWIVEL	100R17
H31	FEMALE, 37° JIC, SWIVEL	FEMALE, 37° JIC, SWIVEL	100R17
H32	SHORT 45°, FEMALE, 37° JIC, SWIVEL	FEMALE, 37° JIC, SWIVEL	100R17
H33	MEDIUM 45°, FEMALE, 37° JIC, SWIVEL	FEMALE, 37° JIC, SWIVEL	100R17
H34	SHORT 90°, FEMALE, 37° JIC, SWIVEL	FEMALE, 37° JIC, SWIVEL	100R17
H35	MEDIUM 90°, FEMALE, 37° JIC, SWIVEL	FEMALE, 37° JIC, SWIVEL	100R17
H36	LONG 90°, FEMALE, 37° JIC, SWIVEL	FEMALE, 37° JIC, SWIVEL	100R17
H37	SHORT 45°, FEMALE, 37° JIC, SWIVEL	FEMALE, 37° JIC, SWIVEL	100R4
H38	SHORT 90°, FEMALE, 37° JIC, SWIVEL	FEMALE, 37° JIC, SWIVEL	100R4
H39	LONG 90°, FEMALE, 37° JIC, SWIVEL	FEMALE, 37° JIC, SWIVEL	100R4
H40	SHORT 90°, FEMALE, 37° JIC, SWIVEL	FEMALE, 37° JIC, SWIVEL	100R16
H43	FEMALE, 37° JIC, SWIVEL	FEMALE, 37° JIC, SWIVEL	100R16
H51	FEMALE, 37° JIC, SWIVEL	FEMALE, 37° JIC, SWIVEL	100R17
H52	SHORT 45°, FEMALE, 37° JIC, SWIVEL	FEMALE, 37° JIC, SWIVEL	100R17
H53	MEDIUM 45°, FEMALE, 37° JIC, SWIVEL	FEMALE, 37° JIC, SWIVEL	100R17
H54	SHORT 90°, FEMALE, 37° JIC, SWIVEL	FEMALE, 37° JIC, SWIVEL	100R17
H55	MEDIUM 90°, FEMALE, 37° JIC, SWIVEL	FEMALE, 37° JIC, SWIVEL	100R17
H56	LONG 90°, FEMALE, 37° JIC, SWIVEL	FEMALE, 37° JIC, SWIVEL	100R17
H57	SHORT 45°, FEMALE, SAE ORFS, SWIVEL	FEMALE, SAE ORFS, SWIVEL	100R13
H58	FEMALE, SAE ORFS, SWIVEL	FEMALE, SAE ORFS, SWIVEL	100R13
H59	MEDIUM 90°, FEMALE, SAE ORFS, SWIVEL	FEMALE, SAE ORFS, SWIVEL	100R13
H60	FEMALE, 37° JIC, SWIVEL	FEMALE, 37° JIC, SWIVEL	100R17
H61	FEMALE, 37° JIC, SWIVEL	FEMALE, 37° JIC, SWIVEL	100R16
H62	SHORT 90°, FEMALE, 37° JIC, SWIVEL	FEMALE, 37° JIC, SWIVEL	100R16
H63	MEDIUM 90°, FEMALE, 37° JIC, SWIVEL	FEMALE, 37° JIC, SWIVEL	100R16
H64	LONG 90°, FEMALE, 37° JIC, SWIVEL	FEMALE, 37° JIC, SWIVEL	100R16
H65	MEDIUM 67°, FEMALE, 37° JIC, SWIVEL	FEMALE, 37° JIC, SWIVEL	100R12
H66	FEMALE, 37° JIC, SWIVEL	NO FITTING	100R4
H67	FEMALE, 37° JIC, SWIVEL	FEMALE, 37° JIC, SWIVEL	100R19
H68	SHORT 45°, FEMALE, 37° JIC, SWIVEL	FEMALE, 37° JIC, SWIVEL	100R19
H69	MEDIUM 90°, FEMALE, 37° JIC, SWIVEL	FEMALE, 37° JIC, SWIVEL	100R19
H70	LONG 90°, FEMALE, 37° JIC, SWIVEL	FEMALE, 37° JIC, SWIVEL	100R19
H71	LONG 90°, FEMALE, SAE ORFS, SWIVEL	FEMALE, SAE ORFS, SWIVEL	100R15

7.2 Hydraulic Hoses - Base

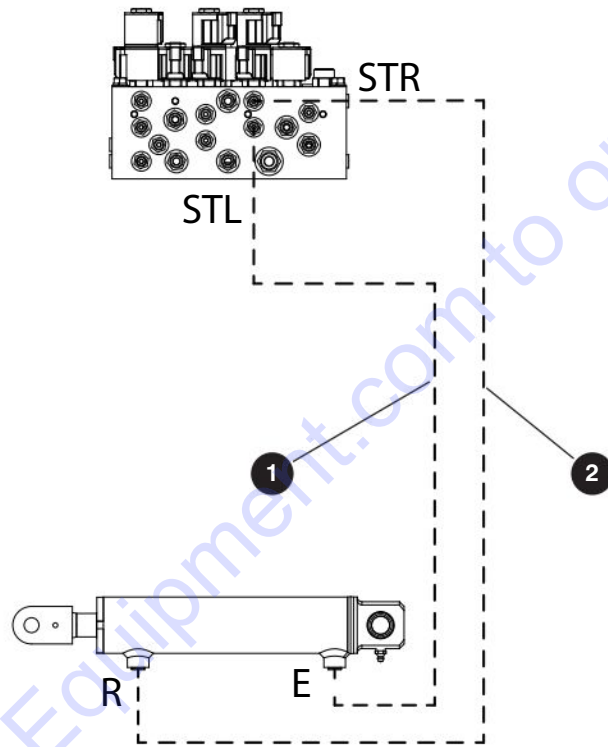

M192816AC

229034ADA

146

SJ30 AJE, SJ30 ARJE

SKYJACK

7.2 Hydraulic Hoses - Base

Index No.	Hose P/N	From		To	
		Description	Port	Port	Description
-	192816	CHASSIS HOSE KIT			
1	H3104 0065 0	MAIN MANIFOLD	STL	E	STEER CYLINDER
2	H3104 0073 0	MAIN MANIFOLD	STR	R	STEER CYLINDER
Index No.	Skyjack Part No.	Qty.	Description		
3	924699	12"	WRAP, Spiral (not shown)		

7.3 Hydraulic Hoses - Turret

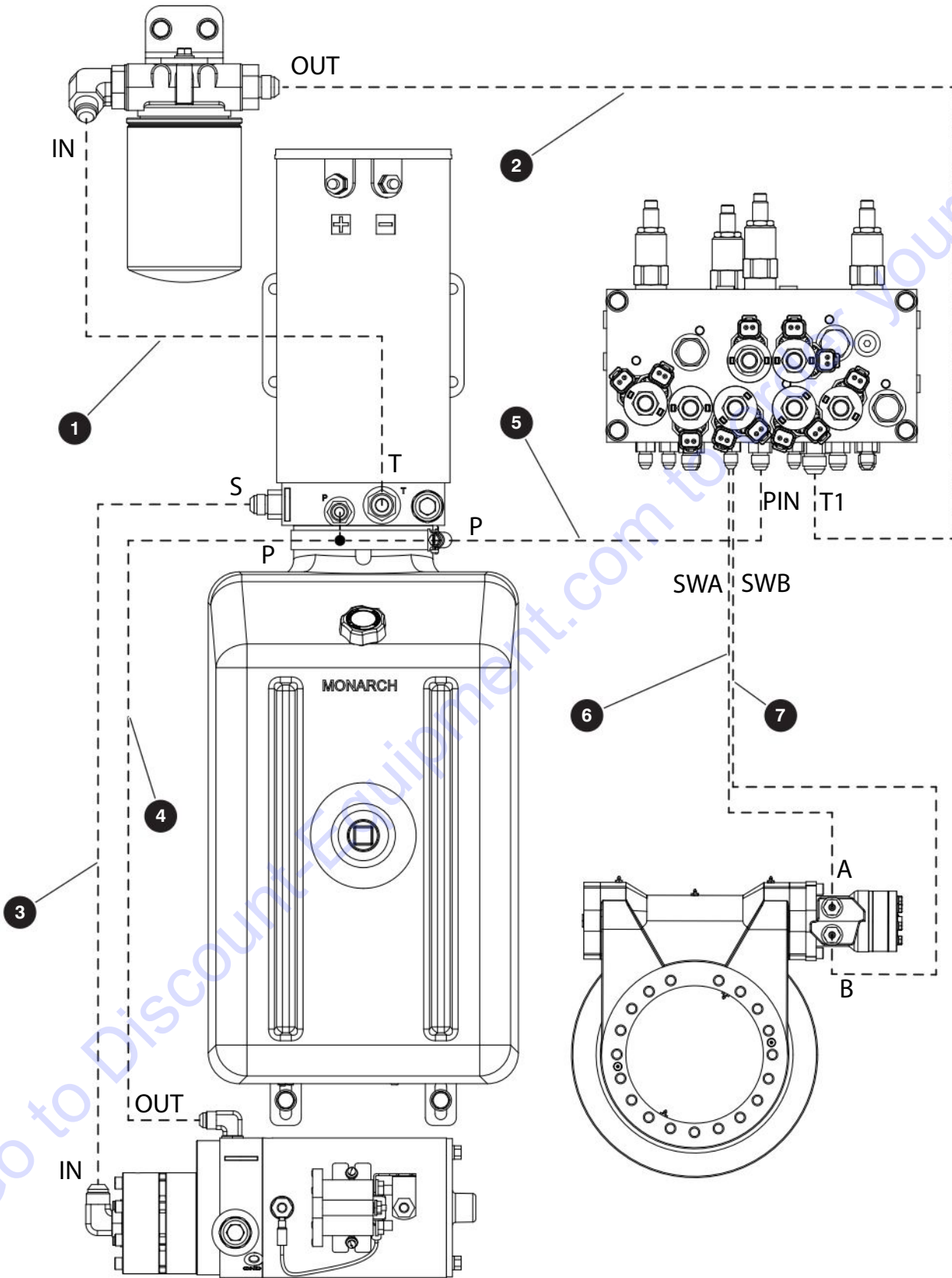

M207245AB

229034ADA

SJ30 AJE, SJ30 ARJE

7.3 Hydraulic Hoses - Turret

Index No.	Hose P/N	From		To		
		Description	Port	Port	Description	
-	207245	TURRET HOSE KIT				
1	H3408 0020 0	Filter	In	T	Pump Motor Unit	
2	H3108 0080 0	Filter	Out	T1	Main Manifold	
3	H3308 0024 2	E-Pump	In	S	Pump Motor Unit	
4	H3406 0026 1	E-Pump	Out	P	Pump Motor Unit	
5	H3006 0065 0	Pump Motor Unit	2	PIN	Main Manifold	
6	H5404 0023 0	Swing Drive	A	SWA	Main Manifold	
7	H5404 0023 0	Swing Drive	B	SWB	Main Manifold	
Index No.	Skyjack Part No.	Qty.	Description			
8	924699	24"	WRAP, Spiral (not shown)			

7.4 Hydraulic Hoses - Boom

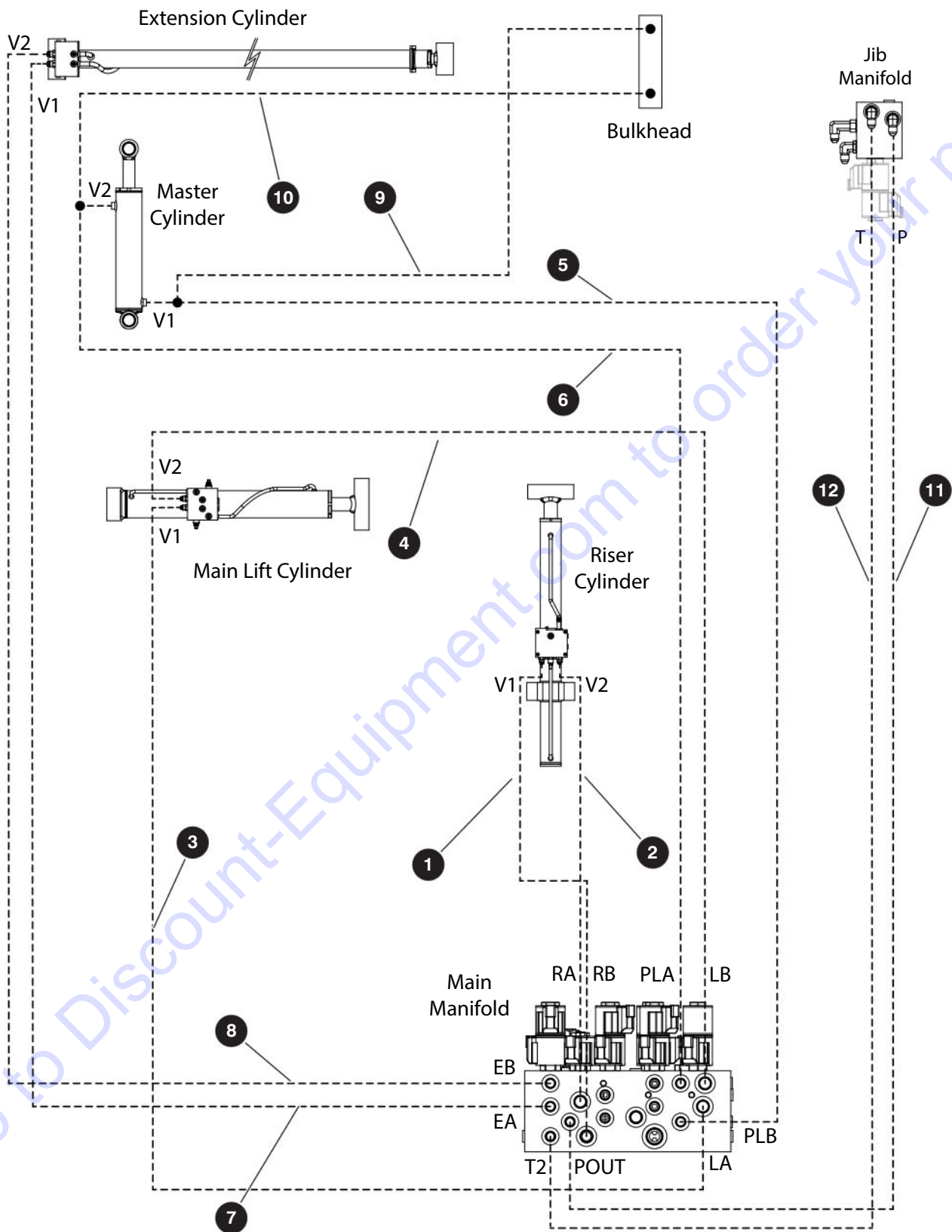

M192877AD

229034ADA

150

SJ30 AJE, SJ30 ARJE

SKYJACK

7.4 Hydraulic Hoses - Boom

Index No.	Hose P/N	From		To		
		Description	Port	Port	Description	
-	192877	RISER HOSE KIT				
1	H3106 0090 0	Riser Cylinder	V1	RA	Main Manifold	
2	H3106 0090 0	Riser Cylinder	V2	RB	Main Manifold	
3	H3106 0206 0	Main Lift Cylinder	V1	LA	Main Manifold	
4	H3106 0202 0	Main Lift Cylinder	V2	LB	Main Manifold	
5	H3104 0186 0	Master Cylinder	V1	PLB	Main Manifold	
6	H3104 0190 0	Master Cylinder	V2	PLA	Main Manifold	
7	H3104 0195 0	Extension Cylinder	V1	EA	Main Manifold	
8	H3104 0195 0	Extension Cylinder	V2	EB	Main Manifold	
9	H3104 0222 0	Master Cylinder	V1	V1	Bulkhead	
10	H3104 0222 0	Master Cylinder	V2	V2	Bulkhead	
11	H3104 0388 0	Jib Manifold	P	POUT	Main Manifold	
12	H3104 0388 0	Jib Manifold	T	T2	Main Manifold	

Index No.	Skyjack Part No.	Qty.	Description
13	163418	45"	SLEEVE, Hose protection (HG-64) (not shown)
14	131732	90"	SLEEVE, Hose protection (HG-46) (not shown)
15	924699	120"	WRAP, Spiral (not shown)

PARTS FINDER

**Search Website
by Part Number**



**Search Manual
Library For Parts
Manual & Lookup Part
Numbers – Purchase
or Request Quote**

Search Manuals

Enter your information to help us find the right parts manual for your machine.

* Brand:

* Model:

* Serial:

* Part Number:

SEARCH

**Can't Find Part or
Manual? Request Help
by Manufacturer,
Model & Description**

Parts Order Form

Please fill in the following information to help us find the right part for your machine.

Manufacturer:	<input type="text"/>
Model:	<input type="text"/>
Description:	<input type="text"/>
Part Number:	<input type="text"/>
Quantity:	<input type="text"/>
Notes:	<input type="text"/>

Discount-Equipment.com is your online resource for quality parts & equipment.

Florida: **561-964-4949** Outside Florida TOLL FREE: **877-690-3101**

Need parts?

Click on this link: <http://www.discount-equipment.com/category/5443-parts/> and choose one of the options to help get the right parts and equipment you are looking for. Please have the machine model and serial number available in order to help us get you the correct parts. If you don't find the part on the website or on one of the online manuals, please fill out the request form and one of our experienced staff members will get back to you with a quote for the right part that your machine needs.

We sell worldwide for the brands: Genie, Terex, JLG, MultiQuip, Mikasa, Essick, Whiteman, Mayco, Toro Stone, Diamond Products, Generac Magnum, Airman, Haulotte, Barreto, Power Blanket, Nifty Lift, Atlas Copco, Chicago Pneumatic, Allmand, Miller Curber, Skyjack, Lull, Skytrak, Tsurumi, Husquvarna Target, Stow, Wacker, Sakai, Mi-T-M, Sullair, Basic, Dynapac, MBW, Weber, Bartell, Bennar Newman, Haulotte, Ditch Runner, Menegotti, Morrison, Contec, Buddy, Crown, Edco, Wyco, Bomag, Laymor, EZ Trench, Bil-Jax, F.S. Curtis, Gehl Pavers, Heli, Honda, ICS/PowerGrit, IHI, Partner, Imer, Clipper, MMD, Koshin, Rice, CH&E, General Equipment, Amida, Coleman, NAC, Gradall, Square Shooter, Kent, Stanley, Tamco, Toku, Hatz, Kohler, Robin, Wisconsin, Northrock, Oztec, Toker TK, Rol-Air, APT, Wylie, Ingersoll Rand / Doosan, Innovatech, Con X, Ammann, Mecalac, Makinex, Smith Surface Prep, Small Line, Wanco, Yanmar

7.5 Hydraulic Hoses - Jib

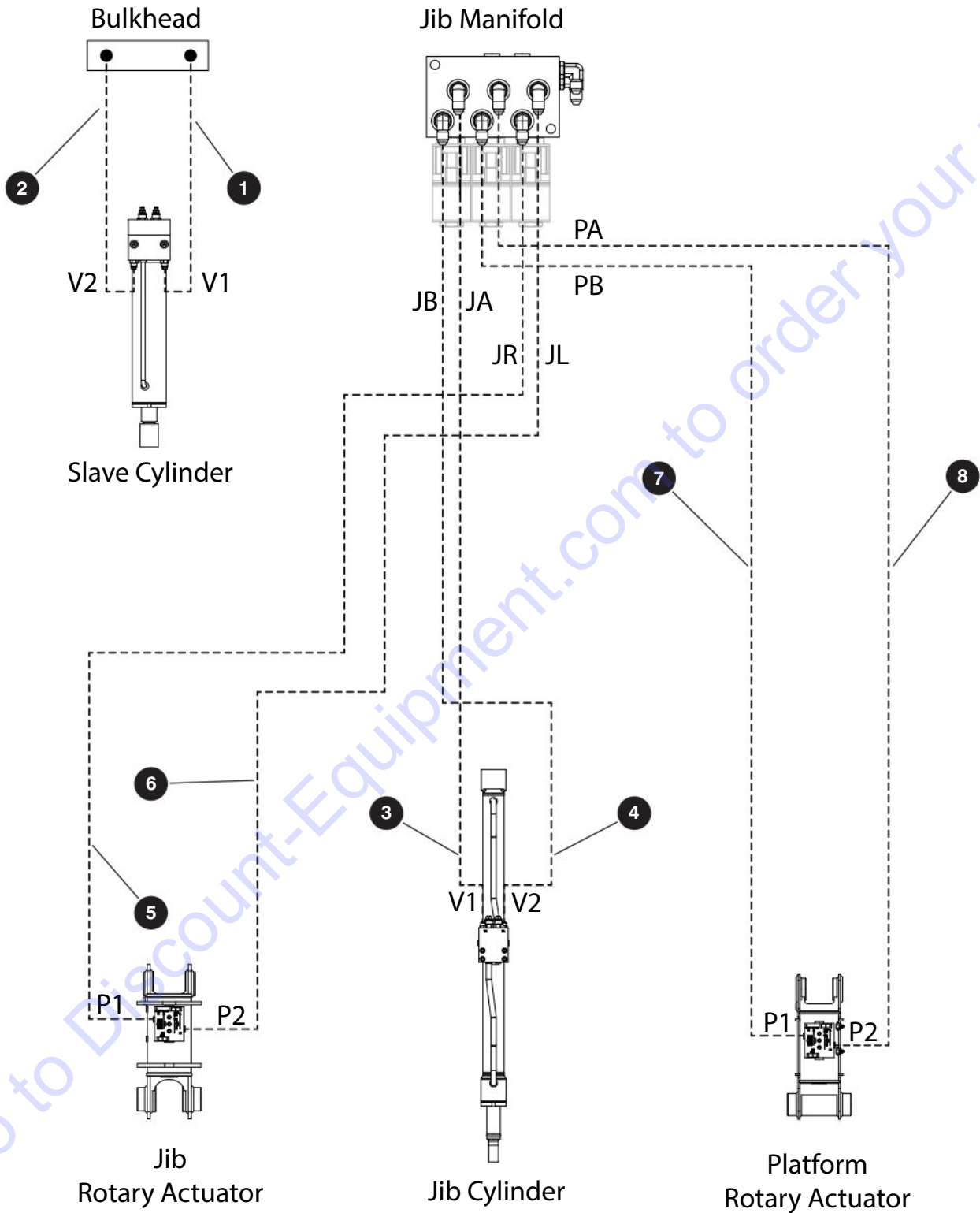

M192914AB

229034ADA

SJ30 AJE, SJ30 ARJE

7.5 Hydraulic Hoses - Jib

Index No.	Hose P/N	From		To		
		Description	Port	Port	Description	
-	192913	ROTATING JIB HOSE KIT				
1	H3104 0027 2	Bulkhead	V1	V1	Slave Cylinder	
2	H3104 0027 2	Bulkhead	V2	V2	Slave Cylinder	
3	H3104 0072 0	Jib Cylinder	V1	JA	Jib Manifold	
4	H3104 0072 0	Jib Cylinder	V2	JB	Jib Manifold	
5	H3404 0056 0	Jib Rotary Actuator	P1	JR	Jib Manifold	
6	H3404 0052 0	Jib Rotary Actuator	P2	JL	Jib Manifold	
7	H3404 0102 0	Platform Rotary Actuator	P1	PB	Jib Manifold	
8	H3404 0112 0	Platform Rotary Actuator	P2	PA	Jib Manifold	
-	192914	NON-ROTATING JIB HOSE KIT				
1	H3104 0027 2	Bulkhead	V1	V1	Slave Cylinder	
2	H3104 0027 2	Bulkhead	V2	V2	Slave Cylinder	
3	H3104 0072 0	Jib Cylinder	V1	JA	Jib Manifold	
4	H3104 0072 0	Jib Cylinder	V2	JB	Jib Manifold	
5	H3404 0102 0	Platform Rotary Actuator	P1	PB	Jib Manifold	
6	H3404 0112 0	Platform Rotary Actuator	P2	PA	Jib Manifold	
Index No.	Skyjack Part No.	Qty.	Description			
9	163418	110"	SLEEVE, Hose protection (HG-64) (not shown)			

Section 8 – Optional Equipment

- 8.1 *Inverter*
- 8.2 *Inverter Shut-Off Timer*
- 8.3 *Pipe Rack*
- 8.4 *Flashing Light*
- 8.5 *Control Box Cover*
- 8.6 *Tool Caddy*
- 8.7 *Additional Anti-Overriding Posts - KC*
- 8.8 *Seconday Guarding - Electrical (SGE) - KC*
- 8.9 *Air Line*
- 8.10 *Platform Mesh*
- 8.11 *Elevate Telematics*
- 8.12 *Elevate Telematics Subscription*

8.1 Inverter

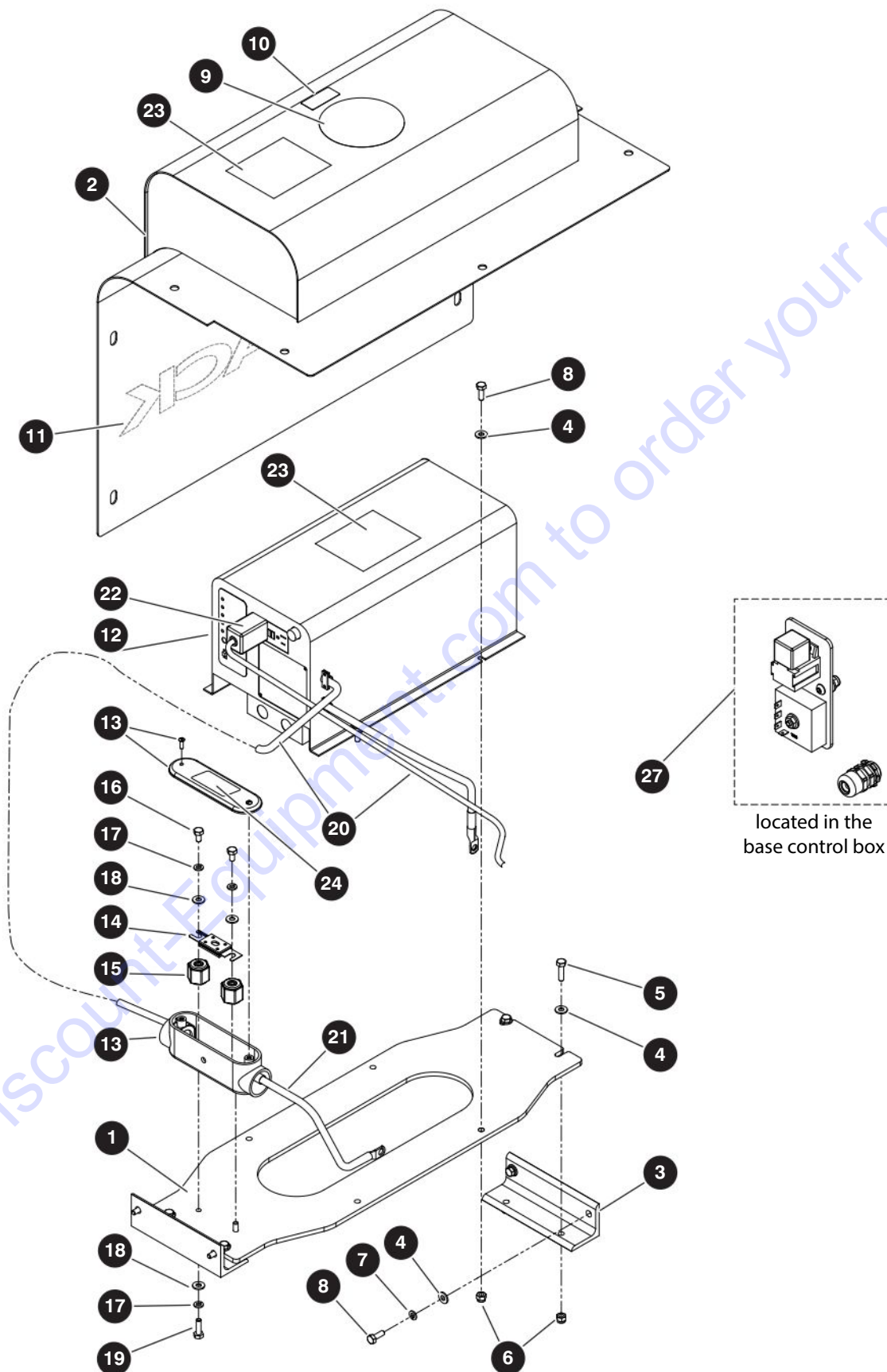

M192840AD

229034ADA

SJ30 AJE, SJ30 ARJE

8.1 Inverter

Index No.	Skyjack Part No.	Qty.	Description
-	207395	1	INVERTER - 800W 120V AC - ANSI/CSA
-	192841	1	• INVERTER MECHANICAL ASSEMBLY
1	192708	1	• • PLATE, Inverter mount
2	192717	1	• • COVER, Inverter
3	192847	2	• • BRACKET, Support angle
4	103995	12	• • WASHER, Flat (0.25" SAE)
5	103857	4	• • BOLT, Hex head (0.25"-20 x 1.00" gr 5)
6	115649	8	• • NUT, Lock (0.25"-20 gr 5 nylon)
7	104000	4	• • WASHER, Lock (0.25")
8	103856	8	• • BOLT, Hex head (0.25"-20 x 0.75" gr 5)
9	167996	1	• • LABEL, Warning high voltage
10	115543	1	• • LABEL, No step
11	172272	1	• • LABEL, Skyjack logo
-	192169	1	• INVERTER ELECTRICAL ASSEMBLY
12	124755	1	• • INVERTER, 120V @ 60 Hz, 48 volt
13	119061	1	• • BOX, Fuse
14	103068	2	• • INSULATOR, Fuse
15	138094	1	• • FUSE, 125 amp
16	103855	2	• • BOLT, Hex head (0.25"-20 x 0.50" gr 5)
17	104000	4	• • WASHER, Lock (0.25")
18	103995	4	• • WASHER, Flat (0.25")
19	103891	2	• • BOLT, Hex head (0.25"-20 x 0.875" gr 5)
20	192170	2	• • CABLE, Battery (#4 GA 0.3125" x 16.0")
21	192171	1	• • CABLE, Battery (#4 GA 0.375" x 16.0" x 0.3125" (+,+))
22	169396	1	• • CORD, Extension - inverter
	104208	1	• • • PLUG, Male
	133868	1	• • • PLUG, Female
23	130115	3	• • LABEL, Inverter power supply
24	172430	2	• • LABEL, 125A
25	102892	10	• TIES, Cable (not shown)
26	209367	1	• INSTRUCTIONS, Inverter installation (not shown)
27	213876	1	SERVICE KIT, INVERTER SHUTOFF - ANSI/CSA (For components, refer to 8.2 Inverter Shut-Off Timer)

8.2 Inverter Shut-Off Timer

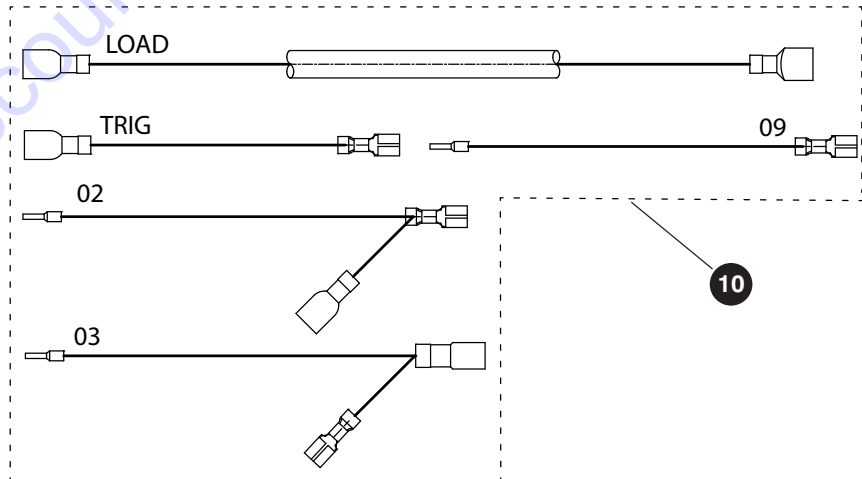
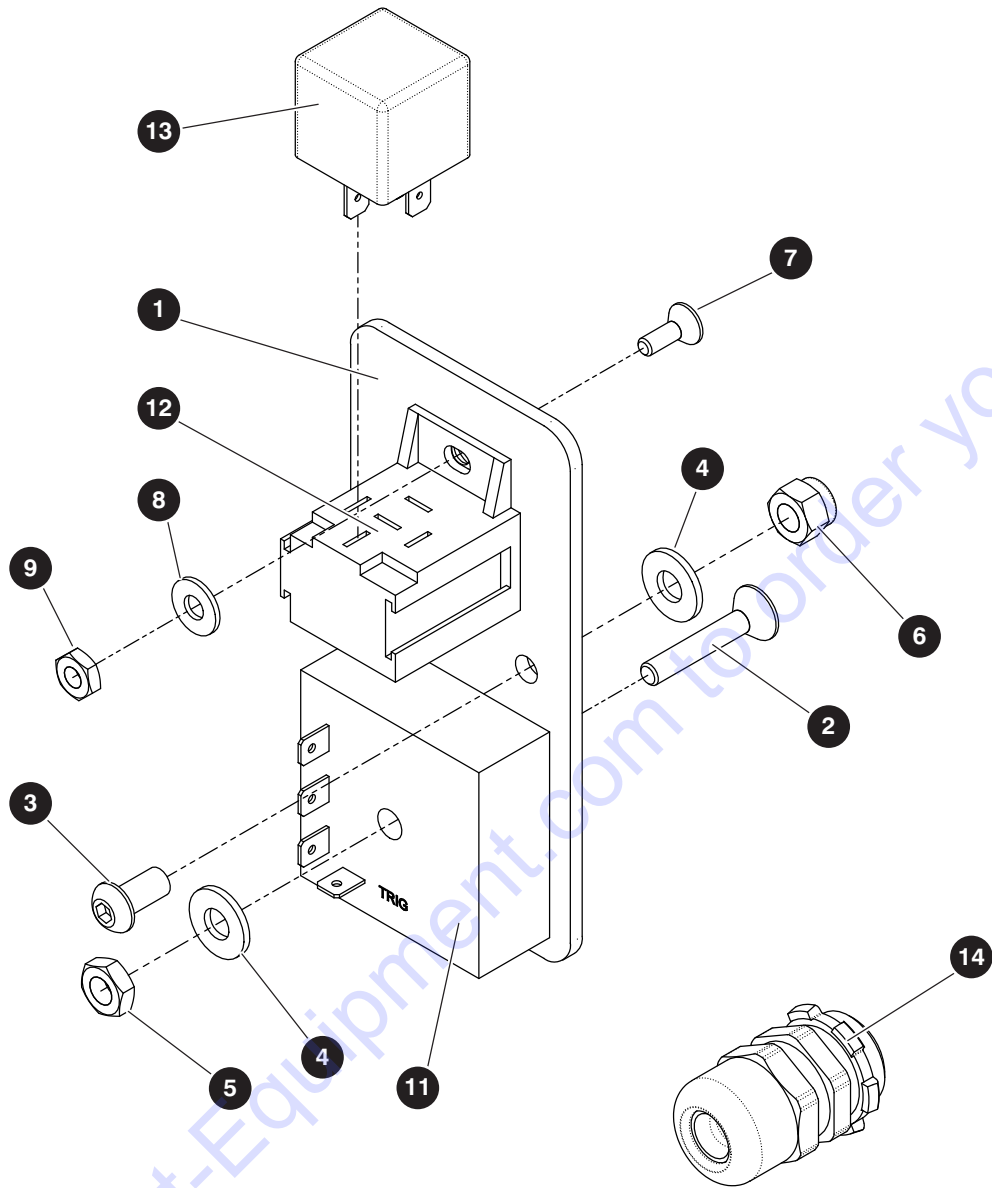

M220930AA

229034ADA

8.2 Inverter Shut-Off Timer

Index No.	Skyjack Part No.	Qty.	Description
-	213876	1	INVERTER SHUTOFF TIMER KIT - ANSI/CSA
-	213878	1	• ELETRICAL ASSEMBLY, Inverter timer
1	213879	1	• • PLATE, Inverter timer panel
2	163397	1	• • SCREW, Flat head hex (0.25-20 x 1.25" gr 5)
3	300060	2	• • BOLT, Button head cap screw (0.25"-20 x 0.50")
4	103995	3	• • WASHER, Flat (0.25")
5	103983	1	• • NUT, Hex head jam (0.25"-20 gr 5)
6	115649	2	• • NUT, Lock (0.25"-20 gr 5)
7	124031	1	• • SCREW, Machine flat head (10-32 x 0.50")
8	104694	1	• • WASHER, Flat (#10)
9	104003	1	• • NUT, Hex (10-32)
10	213880	1	• • WIRING ASSEMBLY, INVERTER TIMER (wires included, not shown)
11	213877	1	• • • RELAY, Timer delay on release
12	138749	1	• • • SOCKET, Relay
13	127131	1	• • • RELAY, 12 V 40 amp
14	103036	1	• RELIEF, Strain
15	113719	10	• TIE, Cable (not shown)
16	213019	1	• INSTRUCTION, Inverter timer install (not shown)

8.3 Pipe Rack

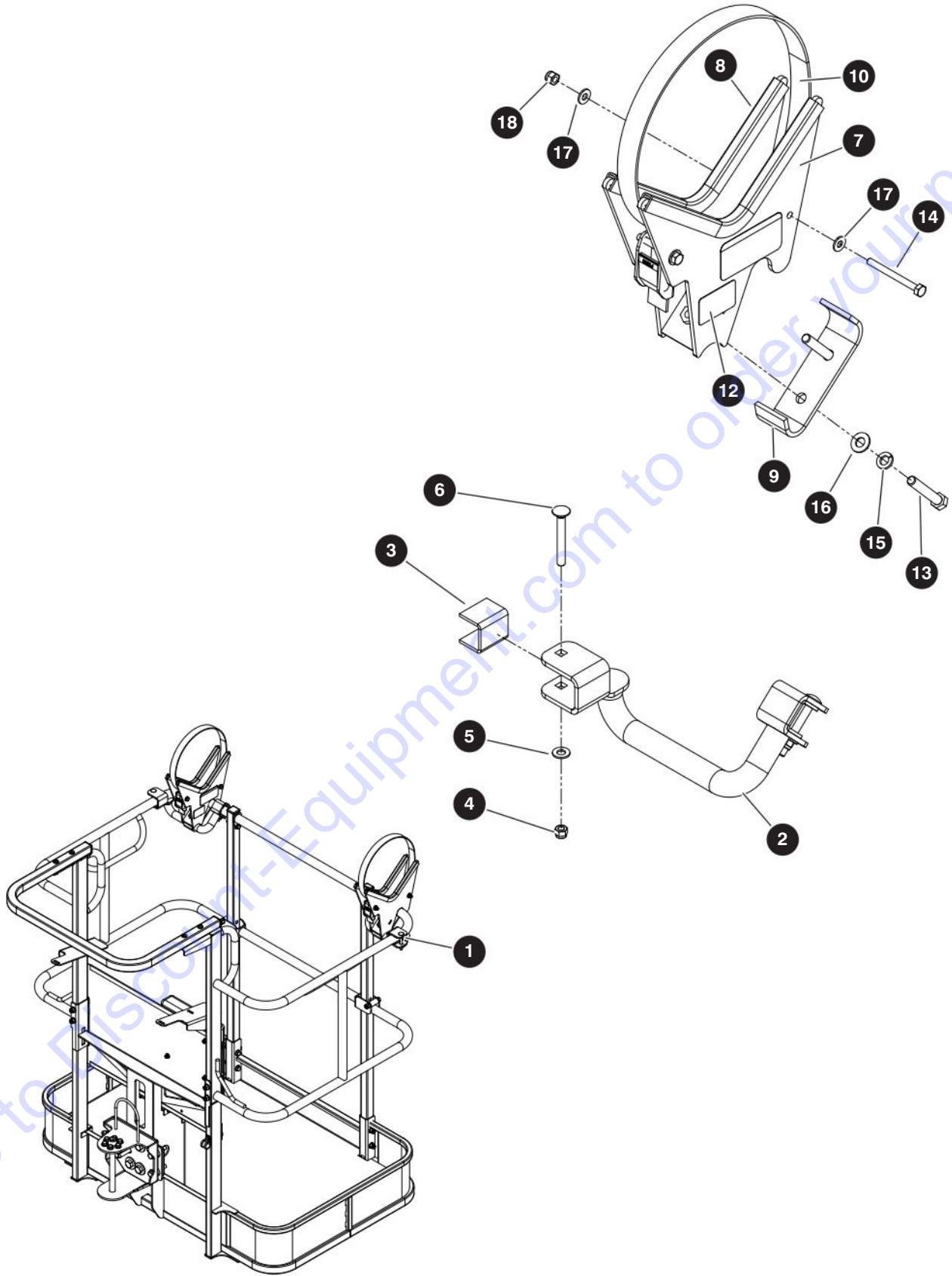

M192820AA

229034ADA

SJ30 AJE, SJ30 ARJE

8.3 Pipe Rack

dex No.	Skyjack Part No.	Qty.	Description
-	207373	1	PIPE RACK & ADAPTER FIELD KIT
-	207399	1	• PIPE RACK ADAPTER KIT
-	192821	1	• • PIPE RACK ADAPTER SET
1	192822	1	• • • WELDMENT, Pipe rack adapter - left
2	192824	1	• • • WELDMENT, Pipe rack adapter - right
3	192819	4	• • • FOAM, Rubber
4	103984	4	• • • NUT, Lock (0.313"-18 gr 5 nylon)
5	103996	4	• • • WASHER, Flat (0.312" SAE)
6	195185	4	• • • BOLT, Carriage (0.3125"-18 x 2.50" gr 5)
-	209364	1	• • INSTRUCTION, Pipe rack adapter installation (not shown)
-	148559	1	• PIPE RACK KIT
-	192818	1	• • PIPE CRADLE SET
7	144495	2	• • • WELDMENT, Cradle
8	117398	48"	• • • TRIM, Protective
9	144499	2	• • • PLATE, Bottom
10	144500	2	• • • STRAP
11	144748	2	• • • LABEL, Pipe rack capacity
12	171239	2	• • • LABEL, Capacity reduction
13	103872	4	• • • BOLT, Hex head (0.375"-16 x 2.25" gr 5)
14	144501	4	• • • BOLT, Hex head (0.25"-20 x 2.75" gr 5)
15	103999	4	• • • WASHER, Lock (0.375")
16	103472	4	• • • WASHER, Flat (0.375" SAE)
17	103995	8	• • • WASHER, Flat (0.25" SAE)
18	115649	4	• • • NUT, Lock (0.25"-20 gr 5 nylon)
19	162725	1	• • INSTRUCTION, Pipe rack operation & installation (not shown)

8.4 Flashing Light

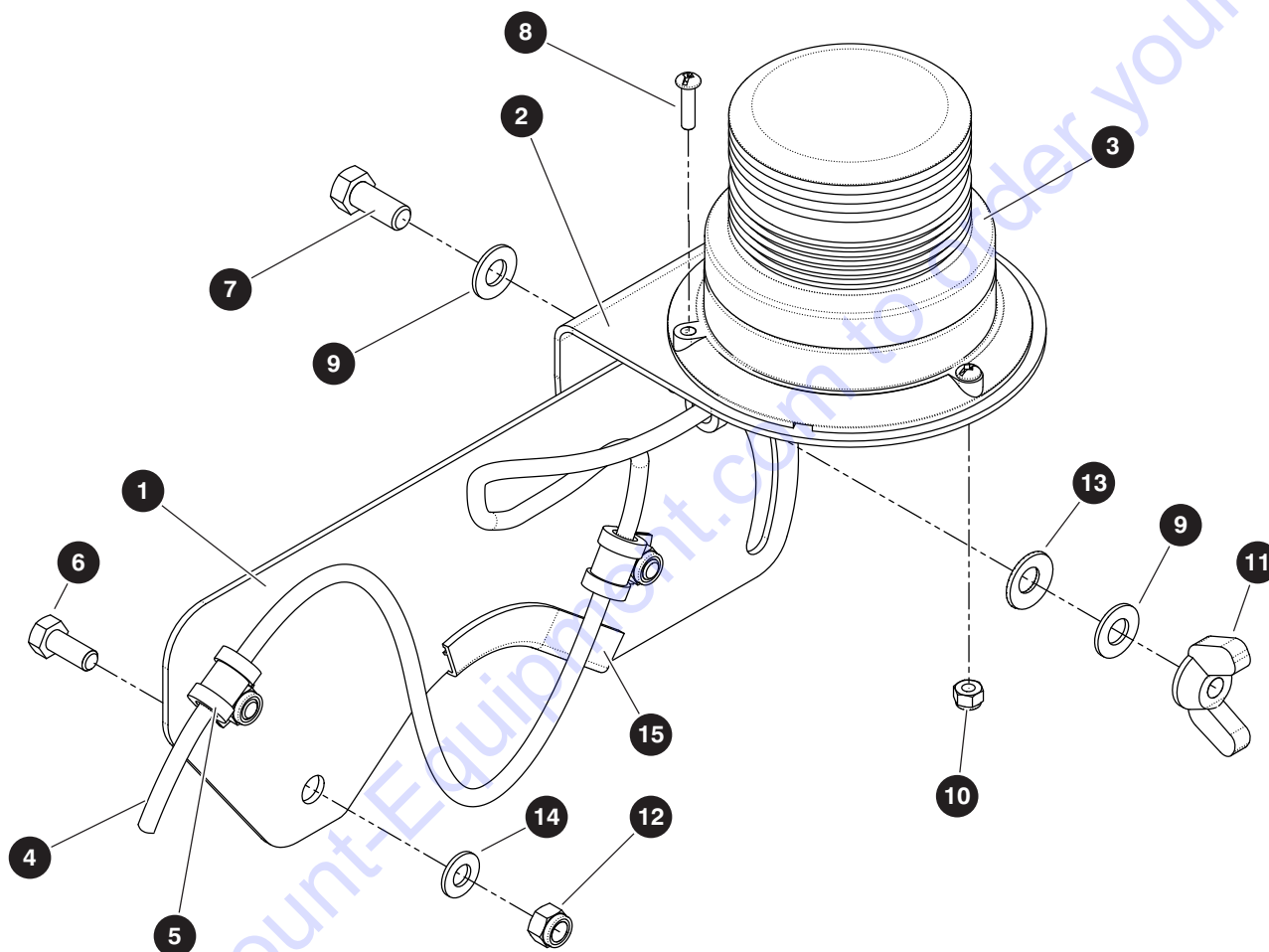

M192622AC

229034ADA

162

SJ30 AJE, SJ30 ARJE

SKYJACK

8.4 Flashing Light

Index No.	Skyjack Part No.	Qty.	Description
-	207394	1	FLASHING LIGHT KIT
-	192622	1	• FLASHING LIGHT
1	192621	1	• • BRACKET, Light mount - slotted
2	192620	1	• • BRACKET, Light mount
3	144078	1	• • LIGHT, Flashing
4	192630	1	• • HARNESS, Flashing light
5	931964	3	• • CLAMP, Tube (0.375")
6	103887	3	• • BOLT, Hex head (0.312"-18 x 0.75" gr 5)
7	300437	1	• • BOLT, Hex head (0.375"-16 x 0.875" gr 5)
8	104698	3	• • SCREW, Round head machine (10-32 x 0.75")
9	103472	2	• • WASHER, Flat (0.375" SAE)
10	300450	3	• • NUT, Lock (10-32 gr 5 nylon)
11	127068	1	• • NUT, Wing (0.375"-16 type A)
12	103984	3	• • NUT, Hex (0.312"-18 gr 5 nylon)
13	192699	1	• • WASHER, Lock - spring (0.375")
14	103996	2	• • WASHER, Flat (0.312" SAE)
15	117398	4"	• • TRIM, Protective
16	102892	3	• TIE, Cable (5.375") (not shown)
17	209366	1	• INSTRUCTION, flashing light install (not shown)

8.5 Control Box Cover

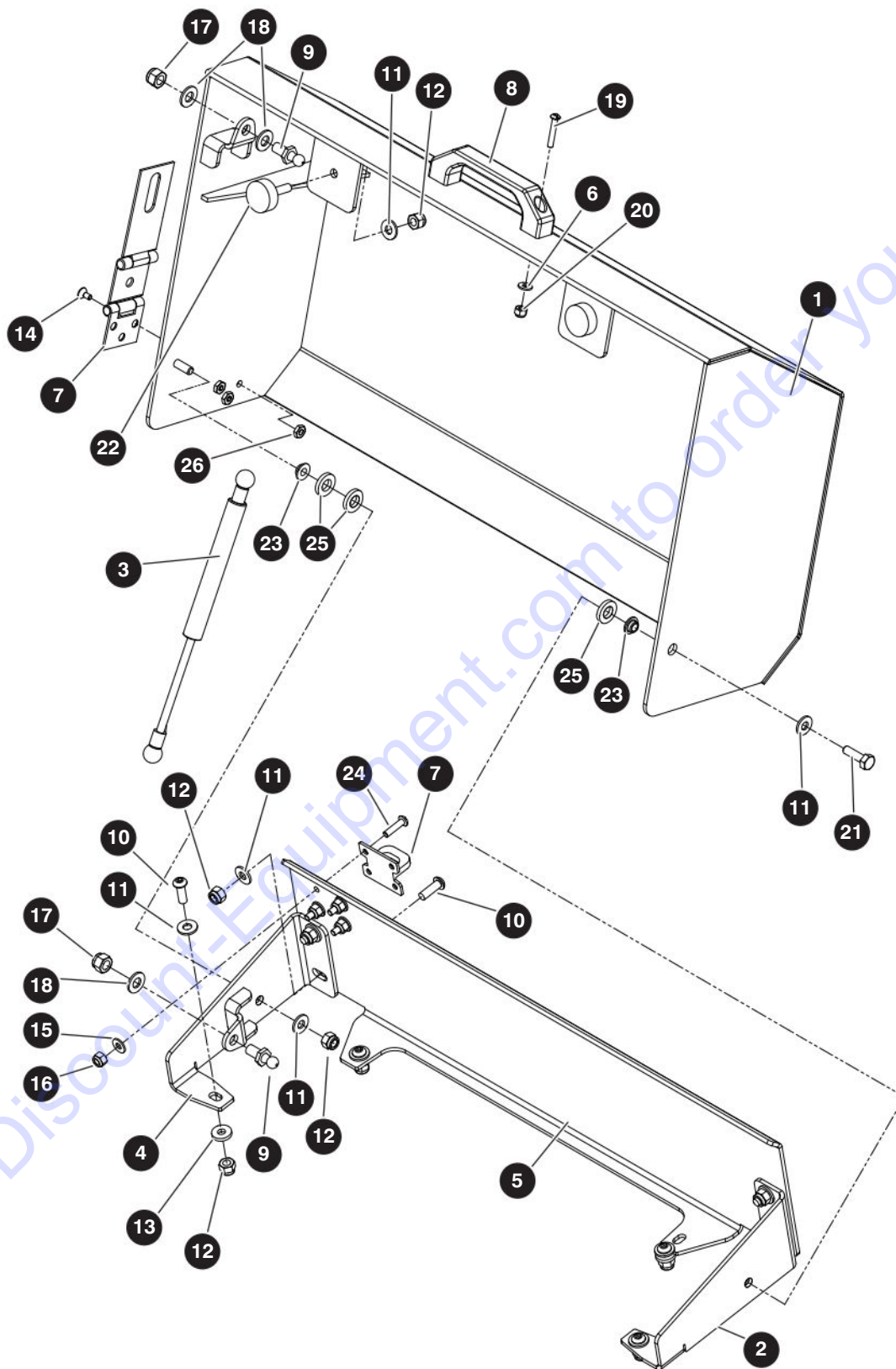

M192745AC

229034ADA

164

SJ30 AJE, SJ30 ARJE

SKYJACK

8.5 Control Box Cover

Index No.	Skyjack Part No.	Qty.	Description
-	207396	1	CONTROL BOX COVER FIELD KIT
-	192745	1	• CONTROL BOX COVER
1	192730	1	• • COVER, Control box
2	192884	1	• • PLATE, Cover - RS
3	162101	1	• • SPRING, Gas (9.3" lg 11 lbf)
4	192735	1	• • PLATE, Cover - LS
5	192732	1	• • PLATE, Back cover
6	103991	2	• • WASHER, Flat (#8)
7	216675	1	• • HASP, Padlock
8	137653	1	• • HANDLE, Pull
9	162123	2	• • STUD, Ball (10 mm x 0.54" lg)
10	139168	8	• • BOLT, Button head cap screw (0.25"-20 x 0.75")
11	103995	14	• • WASHER, Flat (0.25" SAE)
12	115649	12	• • NUT, Lock (0.25"-20 gr 5 nylon)
13	159956	4	• • WASHER, Rubber (0.625" x 0.25" x 0.109)
14	213887	3	• • SCREW, Flat head machine (10-32 x 0.375")
15	104694	4	• • WASHER, Flat (#10)
16	300450	4	• • NUT, Lock (10-32 gr 5 nylon)
17	103984	2	• • NUT, Lock (0.3125"-18 gr 5 nylon)
18	103996	3	• • WASHER, Flat (0.312" SAE)
19	112248	2	• • SCREW, Round head machine (8-32 x 1.00")
20	138765	2	• • NUT, Lock (8-32 gr 5 nylon)
21	103858	2	• • BOLT, Hex head (0.25"-20 x 1.25" gr 5)
22	144015	2	• • MOUNT, Anti vibration (0.25"-20 UNC)
23	154305	2	• • BUSHING, Nylon flanged (0.25")
24	104698	4	• • SCREW, Round head machine (10-32 x 0.75")
25	168336	3	• • SPACER (0.394" ID x 0.75" OD x 0.125" lg nylon)
26	104003	3	• • NUT, Hex (10-32)
27	209368	1	• INSTRUCTION, Control box cover install (not shown)

8.6 Tool Caddy

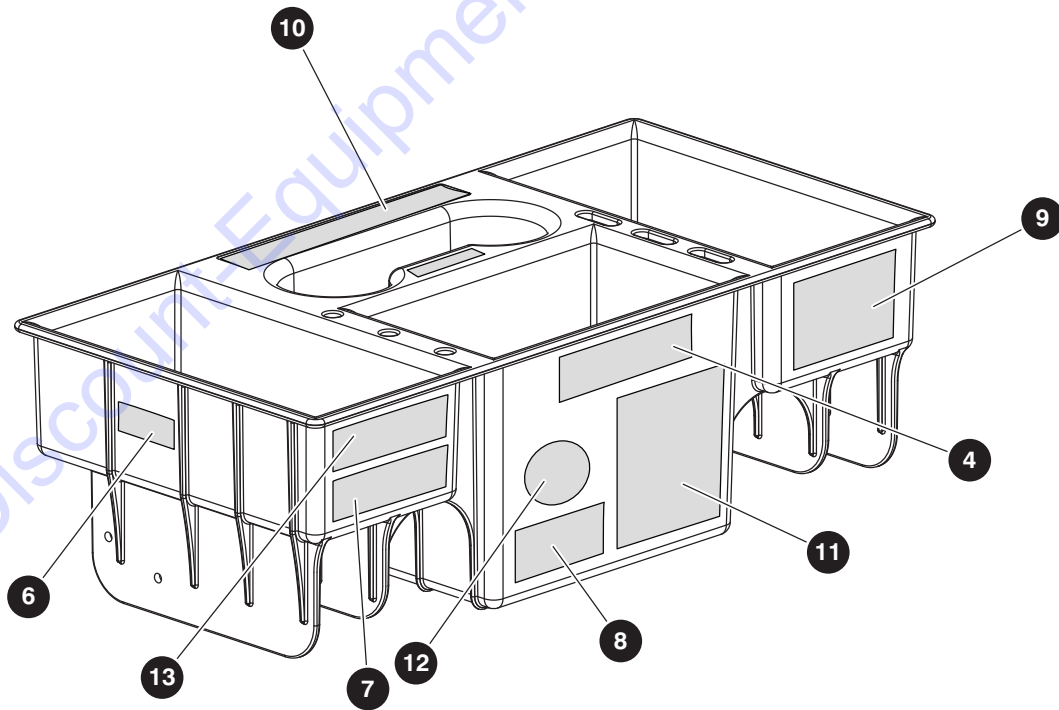
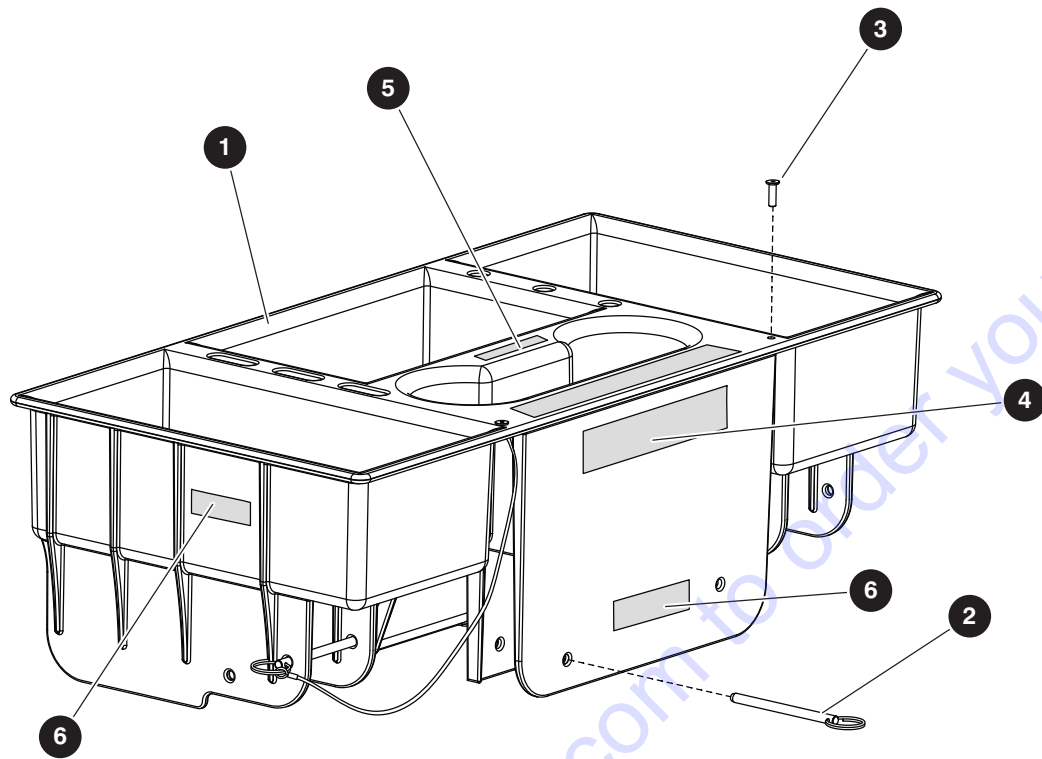

M204334AB

229034ADA

166

SJ30 AJE, SJ30 ARJE

SKYJACK

8.6 Tool Caddy

Index No.	Skyjack Part No.	Qty.	Description
-	211271	1	TOOL CADDY KIT
-	204334	1	• TOOL CADDY ASSEMBLY
1	198945	1	• • TOOL CADDY TRAY, Plastic (Std)
2	198965	2	• • PIN, Quick release 1/4x3.2 LG with Lanyard
3	116161	2	• • RIVET, Pop (0.1875" x 0.565")
4	172293	2	• • LABEL, Skyjack logo, 5" white
5	172294	1	• • LABEL, Skyjack logo, 3" white
6	168421	3	• • LABEL, Lock pin in place
7	172245	1	• • LABEL, Tool caddy weight
8	172246	1	• • LABEL, Tool caddy pin location
9	172247	1	• • LABEL, Tool caddy location
10	172292	1	• • LABEL, Accessoryzers, 8" white
11	172298	1	• • LABEL, Tool caddy models serial numbers
12	172299	1	• • LABEL, Do not block exit/entrance
13	172297	1	• • LABEL, Drive slowly when tool caddy is installed
14	204306	1	• INSTRUCTIONS, Tool caddy installation (not shown)

8.7 Additional Anti-Overriding Posts - KC

Index No.	Skyjack Part No.	Qty.	Description
-	207219	1	ADDITIONAL ANTI-OVERRISING POSTS - KC
1	207858	1	• BRACKET
2	207308	1	• TUBE, Rear
3	207212	1	• CLAMP, Limit Switch
4	207863	1	• TUBE, Front
5	207327	1	• LIMIT SWITCH ASSEMBLY - Long
6	207326	1	• LIMIT SWITCH ASSEMBLY - Short
7	119348	1	• • SWITCH, Limit
8	207485	1	• • HEAD, Spring - limit switch
9	117578	1	• • CONNECTOR, Receptacle (4-pin)
10	117580	1	• • CONNECTOR, Receptacle (4-pin wedge)
11	117590	4	• • CONNECTOR, Pin contact (16-18)
12	208898	1	• • PLUG, Tube
13	208897	1	• • GROMMET, Rubber (0.66" OD x 0.28" ID x 0.42")
14	102892	11	• TIEWRAP, Cable (5.375")
15	138765	4	• NUT, Lock (8-32 gr 5 nylon)
16	103991	4	• WASHER, Flat (#8)
17	207325	4	• SCREW, Socket head cap (8-32 x 1.00")
18	115649	6	• NUT, Lock (0.25"-20 gr 5 nylon)
19	103995	8	• WASHER, Flat (0.25")
20	103860	6	• BOLT, Hex head (0.25"-20 x 1.75" gr 5)
21	192361	4	• SCREW, Wing (0.25"-20 x 0.50" gr 5)
22	103861	2	• BOLT, Hex head (0.25"-20 x 2.00" gr 5)
23	126642	2	• NUT, Lock (10-24 gr 5 nylon)
24	209372	1	INSTRUCTIONS, Additional anti-overriding posts installation (not shown)

8.8 Secondary Guarding - Electrical (SGE) - KC

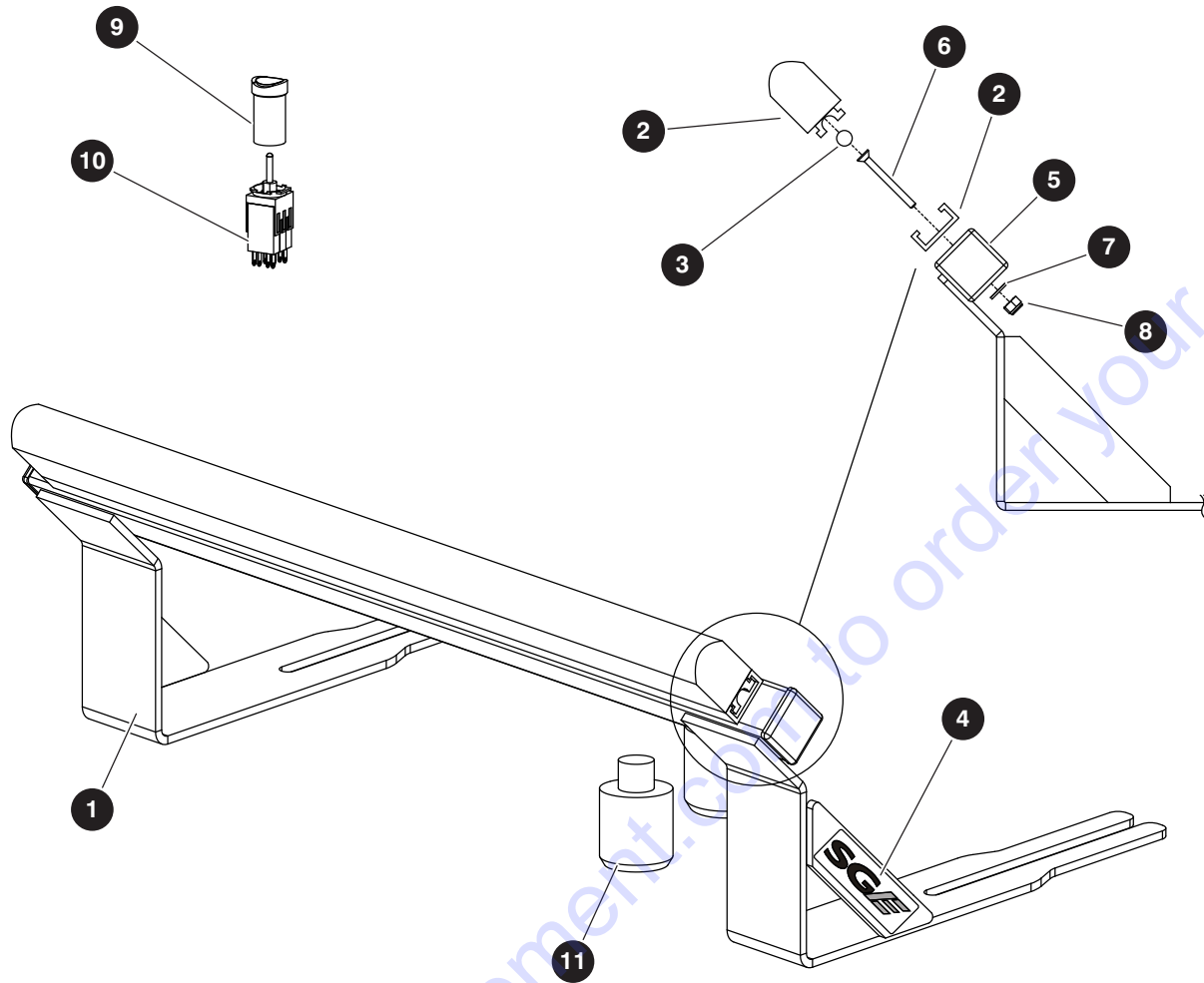

M192850AC

Index No.	Skyjack Part No.	Qty.	Description
-	192850	1	SECONDARY GUARDING - ELECTRICAL (SGE) - KC
-	192146	1	• SGE HARDWARE
1	192149	1	• • BRACKET, SGE sensor
2	192151	1	• • EDGE, Sensing (21" modified rail)
3	192154	1	• • ROD, Sensing edge lock (21")
4	166756	2	• • LABEL, SGE (black/grey)
5	100702	2	• • PLUG, Tube (1.52" x 1.25")
6	166105	3	• • BOLT, Flat head cap screw (10-32 x 1.75" gr 5)
7	104694	3	• • WASHER, Flat (#10)
8	300450	3	• • NUT, Lock (10-32 gr 5 nylon)
-	192158	1	• SGE ELECTRICAL
9	166087	1	• • • PUSHBUTTON, Yellow
10	166086	1	• • • BLOCK, Contact (N/O yellow LED 12-24V)
11	166110	1	• • ALARM/FLASHER, 12V - red LED

8.9 Air Line

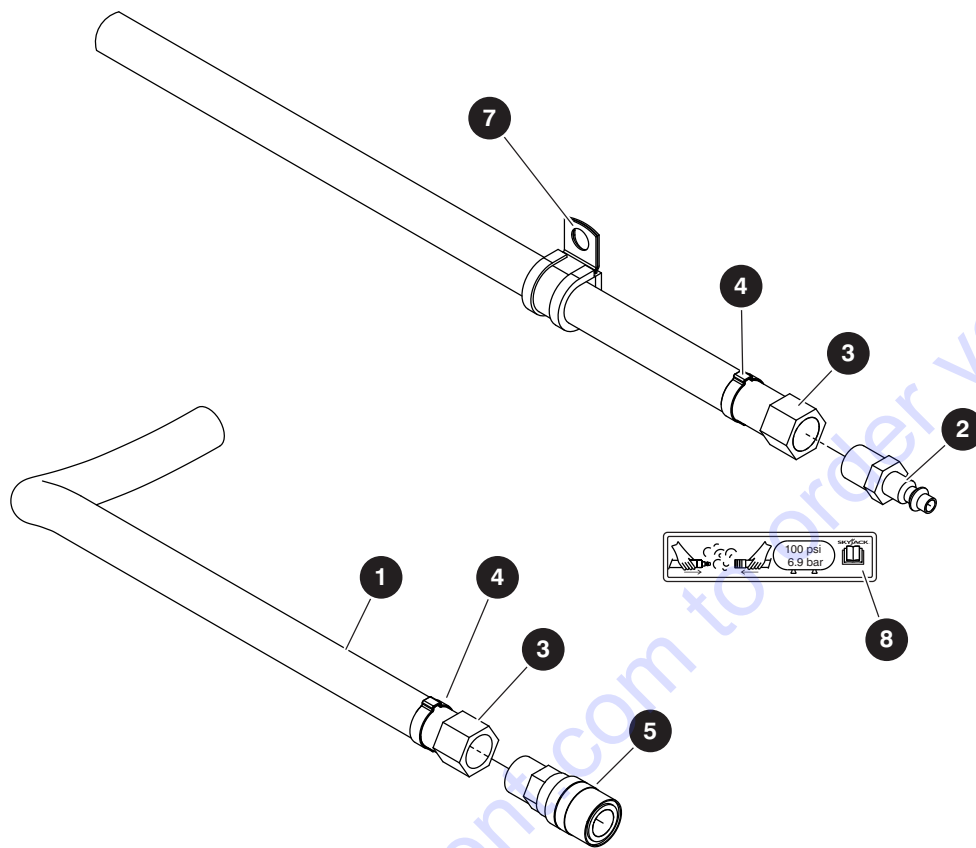

M192619AB

Index No.	Skyjack Part No.	Qty.	Description
-	192619	1	AIR LINE
1	107884	660"	• HOSE, Air (1.50" #8L3)
2	107883	1	• PLUG, Quick disconnect (16.1262")
3	109050	2	• FITTING, Hose barb - brass (#126-*C)
4	107886	2	• CLAMP, Hose
5	107882	1	• FITTING, Quick disconnect (#B22E)
6	102891	10	• TIE, Cable (7.25") (not shown)
7	152402	2	• CLAMP, Tube (0.75")
8	138212	2	• LABEL, Connect air here
9	924699	12"	• WRAP, Spiral (not shown)

8.10 Platform Mesh

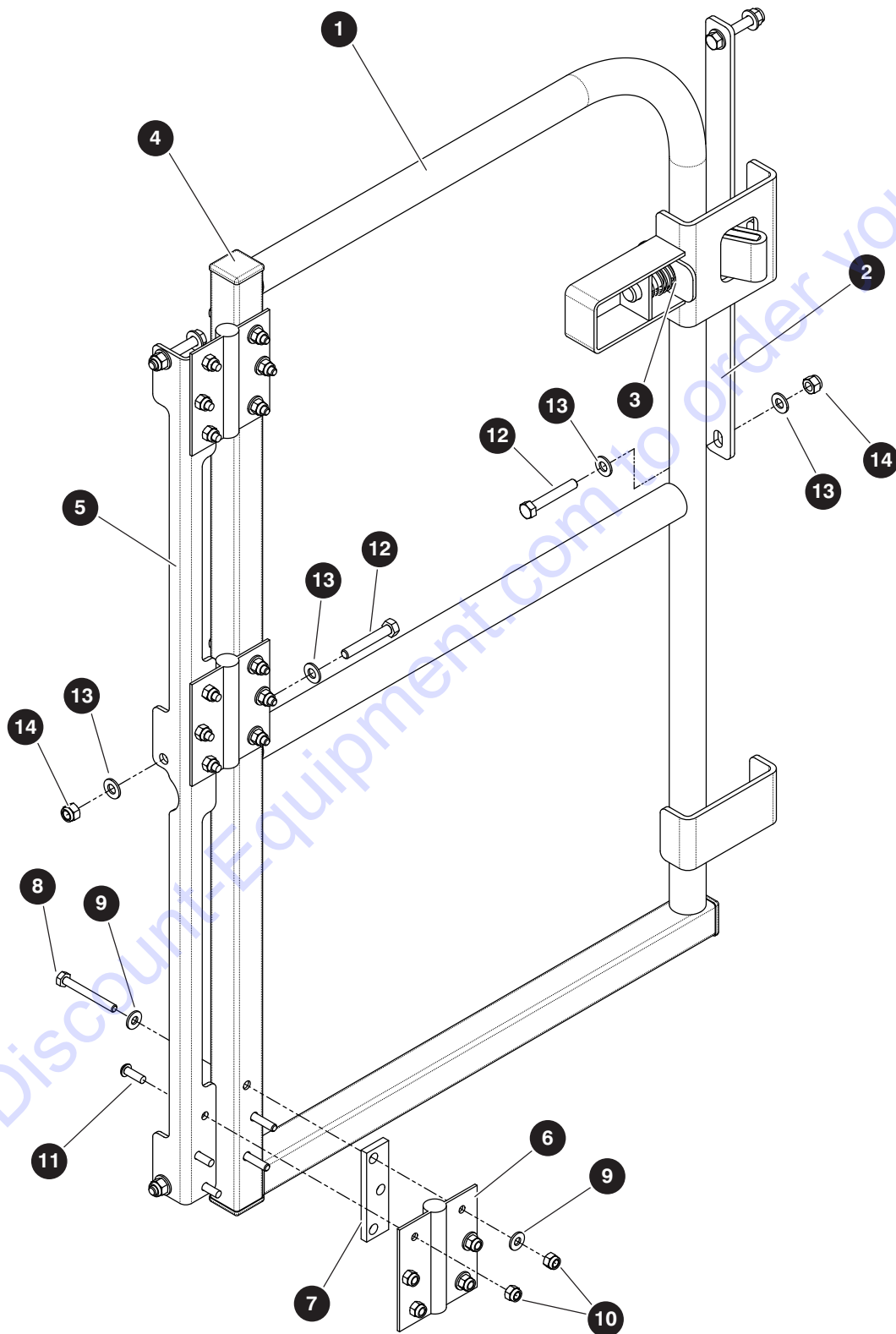

M211359AA

229034ADA

172

SJ30 AJE, SJ30 ARJE

SKYJACK

8.10 Platform Mesh

Index No.	Skyjack Part No.	Qty.	Description
-	223225	1	HALF HEIGHT MESH KIT for 46" x 30" Platform
-	220130	1	• FULL SWING GATE
1	220131	1	• • GATE, Swing - full
2	166288	1	• • PLATE, Locking
3	110824	1	• • LATCH, Pin - door spring
	105312	1	• • • BED, Latch
	109377	1	• • • PIN, Latch (5/8" x 4-3/16")
	105307	1	• • • HANDLE, Latch
	103107	1	• • • SPRING, Compression
	100950		• • • PIN, Spring (1/8" x 1")
4	100702	3	• • PLUG, Tube (1-1/4" x 1-1/4")
5	220146	1	• • BRACKET, Mounting - hinge
6	209527	3	• • HINGE, Spring
7	164592	3	• • TAB, Hinge
8	103862	9	• • BOLT, Hex head (1/4"-20 x 2-1/4" gr 5)
9	103995	18	• • WASHER, Flat (1/4")
10	115649	18	• • NUT, Lock (1/4"-20 gr 5 nylon)
11	139168	9	• • BOLT, Button head cap screw (1/4"-20 x 3/4")
12	103865	5	• • BOLT, Hex head (5/16"-18 x 2" gr 5)
13	103996	10	• • WASHER, Flat (5/16")
14	103984	5	• • NUT, Lock (5/16"-18 gr 5 nylon)
			Parts list continued on the next page.

8.10 Platform Mesh

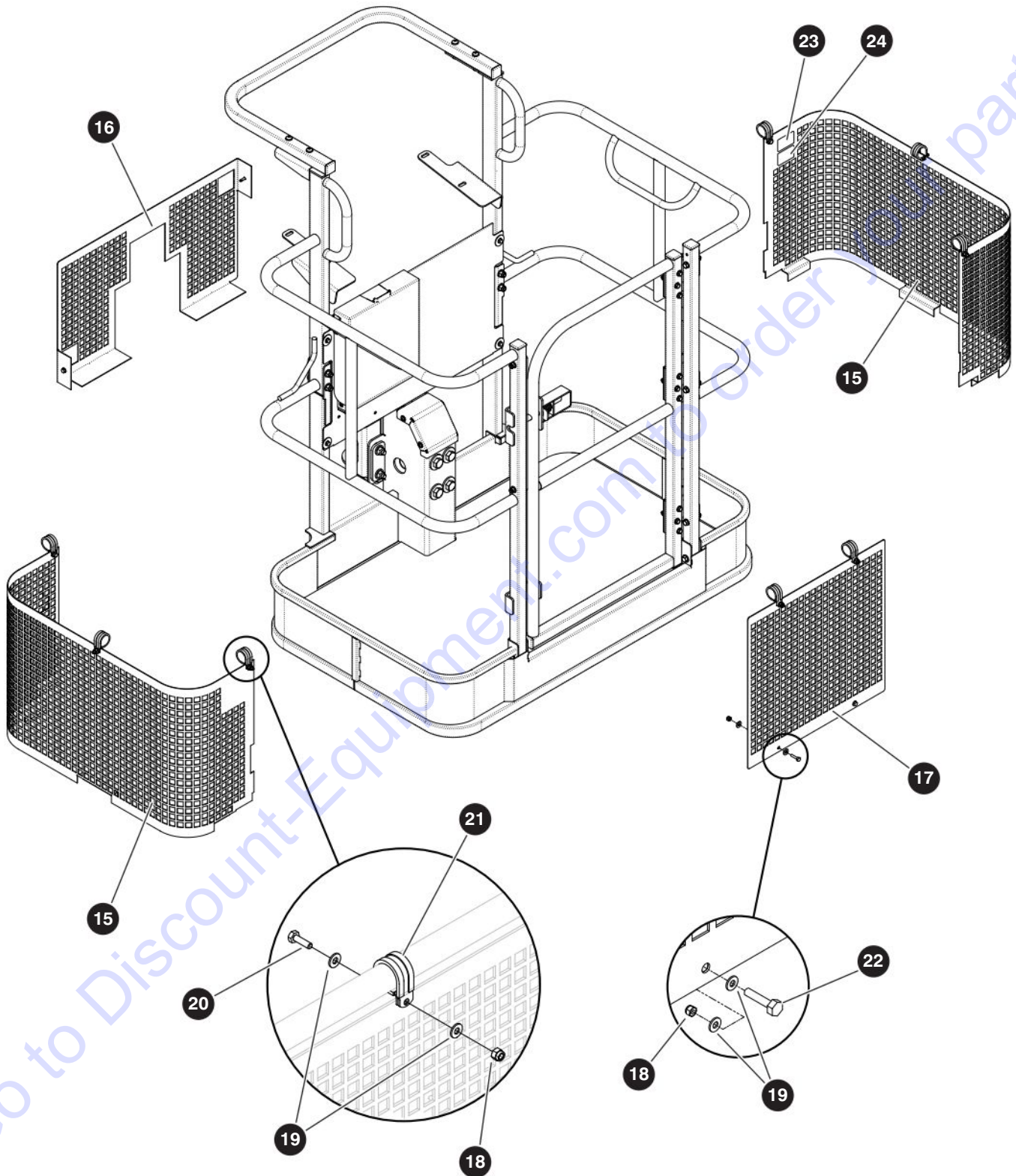

M223225AB

229034ADA

174

SJ30 AJE, SJ30 ARJE

SKYJACK

8.10 Platform Mesh

Index No.	Skyjack Part No.	Qty.	Description
			Parts list continued from the previous page.
15	220139	2	• MESH, Side - 46" x 30" platform
16	220138	1	• MESH, Rear - 46" x 30" platform
17	220137	1	• MESH, Gate - 46" x 30" platform
18	115649	10	• NUT, Lock (1/4"-20 gr 5 nylon)
19	103995	20	• WASHER, Flat (1/4")
20	103891	8	• BOLT, Hex head (1/4"-20 x 7/8" gr 5)
21	209030	8	• CLAMP, Loop - cushioned (#19)
22	103861	2	• BOLT, hex head (1/4"-20 x 2")
23	172985	1	• LABEL, Mesh weight (9 kg/20 lb)
24	173085	1	• LABEL, Wind rating - indoor
25	223191	1	• INSTRUCTION, Half height platform mesh installation (not shown)

8.11 Elevate Telematics

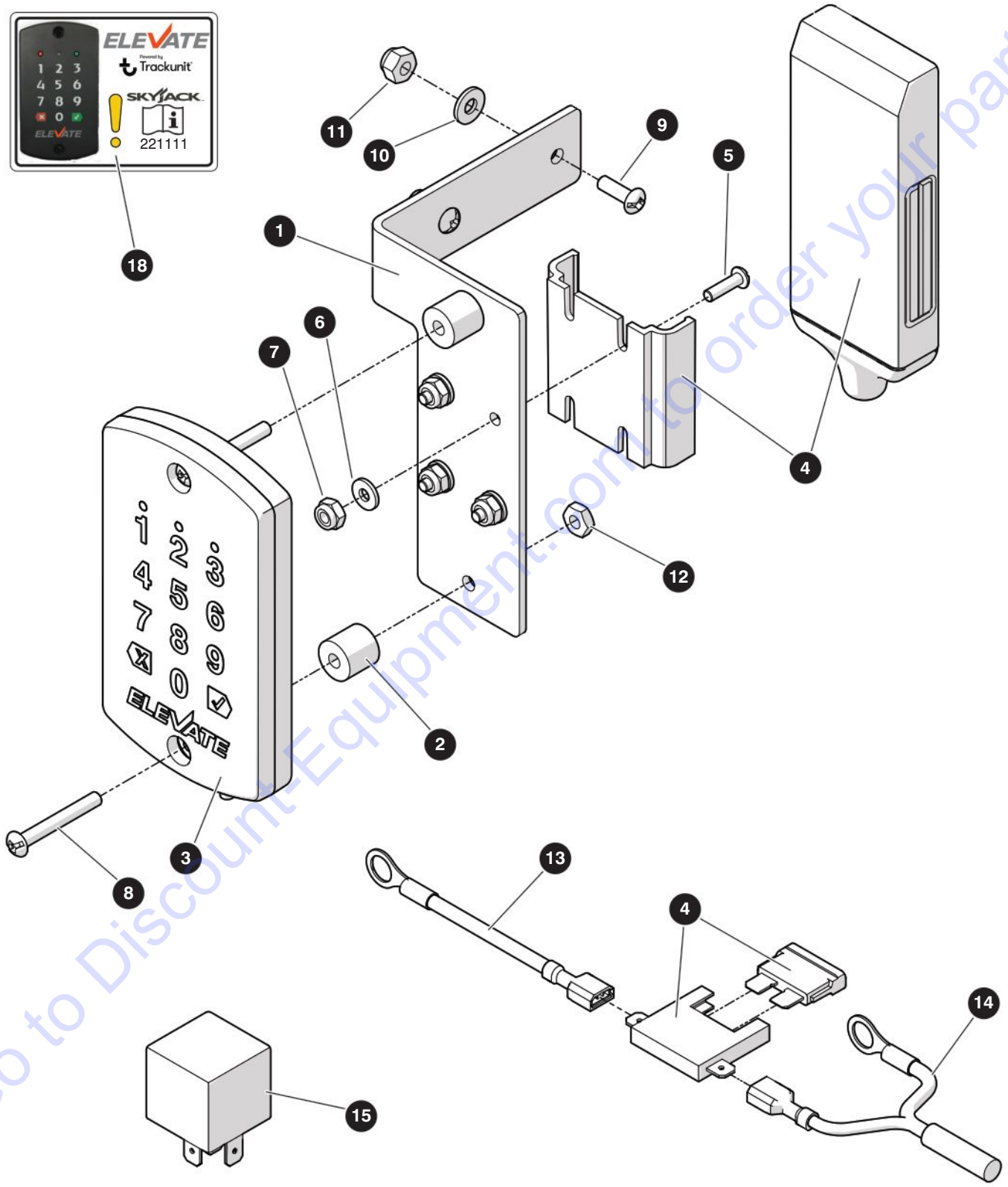

M63872AA

229034ADA

SJ30 AJE, SJ30 ARJE

8.11 Elevate Telematics

Index No.	Skyjack Part No.	Qty.	Description
			 NOTE <i>A subscription is required to use the Elevate Telematics option. Refer to "Elevate Telematics Subscription" on page 178.</i>
A	223253	1	ELEVATE TELEMATICS WITH KEYPAD INSTALLATION KIT
B	223254	1	ELEVATE TELEMATICS WITHOUT KEYPAD INSTALLATION KIT
-	221262	1	• ELEVATE TELEMATICS WITH KEYPAD KIT, A
	221260	1	• ELEVATE TELEMATICS WITHOUT KEYPAD KIT, B
1	221261	1	• • BRACKET, Elevate keypad/GPS mounting
2	211134	2	• • SPACER, Keypad offset, A
3	213099	1	• • TELEMATICS, Elevate keypad, A
4	213098	1	• • TELEMATICS, Elevate GPS ME501-4
	199295	1	• • • COVER
	199296	1	• • • BRACKET
	199297	1	• • • BATTERY
	199298	1	• • • CABLE, Control
	199299	1	• • • FUSE KIT, 1 amp fuse and holder
5	114678	4	• • SCREW, Round head machine (6-32 x 0.50")
6	191833	4	• • WASHER, Flat (#6)
7	196306	4	• • NUT, Lock (6-32 gr 5 nylon)
8	152294	2	• • SCREW, Round head machine (8-32 x 1.25"), A
9	103957	2	• • SCREW, Round head machine (8-32 x 0.50")
10	103991	2	• • WASHER, Flat (#8)
11	207240	2	• • NUT, Lock (8-32 gr 5 SS nylon)
12	103986	2	• • NUT, Hex (8-32), A
13	220577	1	• • WIRE ASSEMBLY, B+
14	221157	1	• • WIRE ASSEMBLY, B+ and 00
15	127131	1	• • RELAY, 12V 40 amp
16	223184	1	• INSTRUCTION, Elevate telematics rework (not shown)
17	221111	1	• INSTRUCTION, Operating - Elevate telematics (not shown)
18	173002	1	• LABEL, Equipped with Elevate keypad, A
19	102892	15	• TIE, Cable (5-3/8") (not shown)

8.12 Elevate Telematics Subscription

Index No.	Skyjack Part No.	Qty.	Description
			 NOTE <i>One of the following subscriptions is required to use the Elevate Telematics option.</i>
1	221153	1	SUBSCRIPTION, Elevate telematics - Monitoring (12 months)
2	221647	1	SUBSCRIPTION, Elevate telematics - Engage (12 months)
3	221348	1	SUBSCRIPTION, Elevate telematics - Engage + Access (12 months)
4	221154	1	SUBSCRIPTION, Elevate telematics - Monitoring (36 months)
5	221650	1	SUBSCRIPTION, Elevate telematics - Engage (36 months)
6	221651	1	SUBSCRIPTION, Elevate telematics - Engage + Access (36 months)
7	221155	1	SUBSCRIPTION, Elevate telematics - Monitoring (60 months)
8	221654	1	SUBSCRIPTION, Elevate telematics - Engage (60 months)
9	221655	1	SUBSCRIPTION, Elevate telematics - Engage + Access (60 months)

Section 9 – Labels

9.1 *Label Kit*

9.2 *Labels - Controls Side*

9.3 *Labels - Tank Side*

9.4 *Labels - Front, Back & Top*

9.5 *Labels - Platform*

9.6 *Labels - Hoses - KC*

The following label kits contain all of the labels required for a complete standard machine, with the exception of:

- Serial number plates
- Platform capacity labels
- Hose labels for KC

Contact Discount-equipment to order those labels individually.

Supply the model number, country and language when ordering label kits.

	ANSI/CSA	CE	AS	KC
SJ30 AJE	211119	N/A	N/A	N/A
SJ30 ARJE	211144	211145	211145	211145

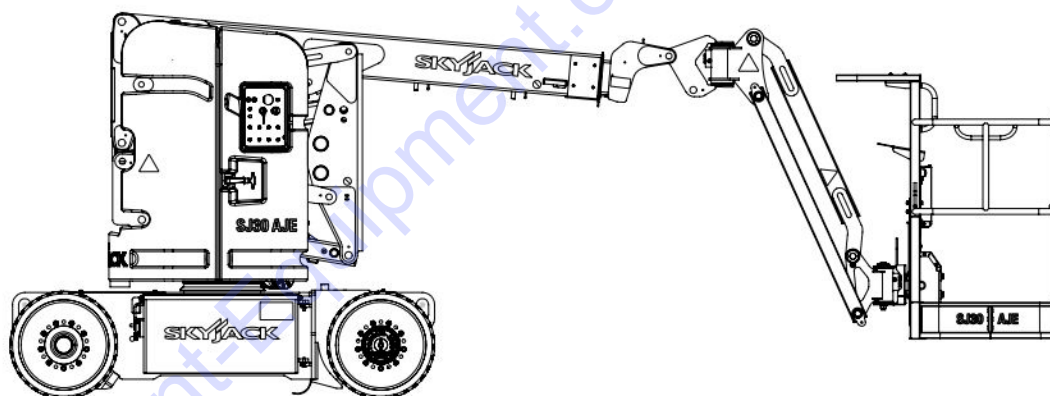

SKYJACK™

9.2 Labels - Controls Side

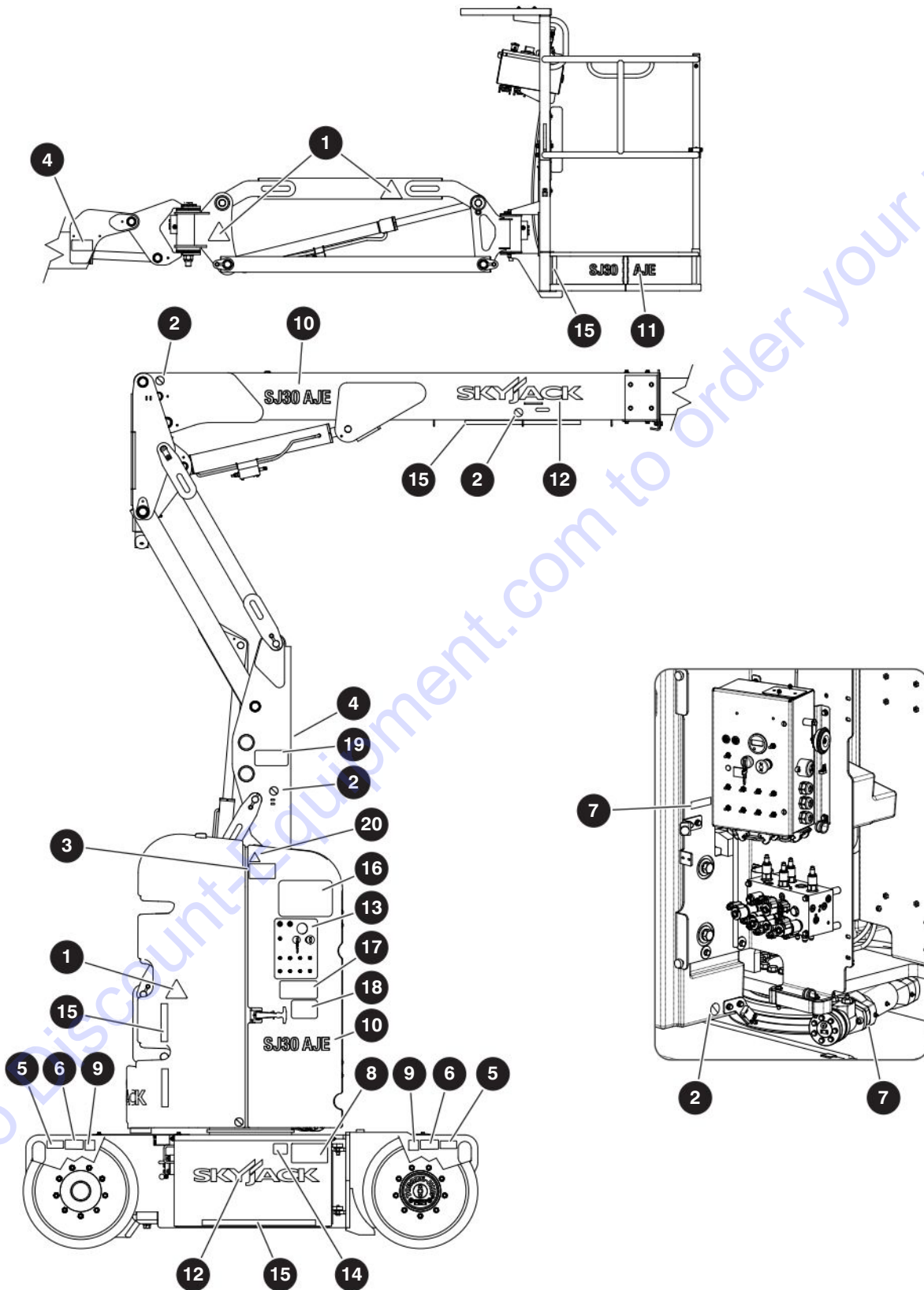

M173204AA_M173205AB_CS

229034ADA

SJ30 AJE, SJ30 ARJE

9.2 Labels - Controls Side

Index No.	Skyjack Part No.	Qty.	Description
1	223640	3	LABEL, Body crush
2	156613	3	LABEL, Do not alter
3	156441	1	LABEL, Annual inspection
4	137988	2	LABEL, Crush/pinch point
5	124767	2	LABEL, Tie down
6	124631	2	LABEL, Wheel info
7	172512	2	LABEL, Grease point Mobil XHO 462 moly
8	226637	1	LABEL, Towing/winch procedure
9	149824	2	LABEL, Wheel load (3255 kg/7180 lb)
10	172273	2	LABEL, "SJ30 AJE" - white (13")
	172275	2	LABEL, "SJ30 ARJE" - white (14")
11	172274	1	LABEL, "SJ30 AJE" - white (10")
	172276	1	LABEL, "SJ30 ARJE" - white (12")
12	172272	2	LABEL, Skyjack logo - white (24")
13	173058	1	LABEL, Base Controls
14	117023	1	LABEL, CE mark - CE
15	119803	60"	TAPE, Caution (1" wide)
16	161631	1	LABEL, Power lines clearance - AS
	173344	2	LABEL, Capacity (136 kg/300 lb), for serial numbers A30000003 to A30000007
17	173061	1	LABEL, Emergency lowering - ANSI/CSA & AS
	173063	1	LABEL, Emergency lowering - CE & KC
18	172939	1	LABEL, Emergency lowering information
19	172680	1	LABEL, Maintenance stand
20	172695	1	LABEL, Warning annual inspection

9.3 Labels - Tank Side

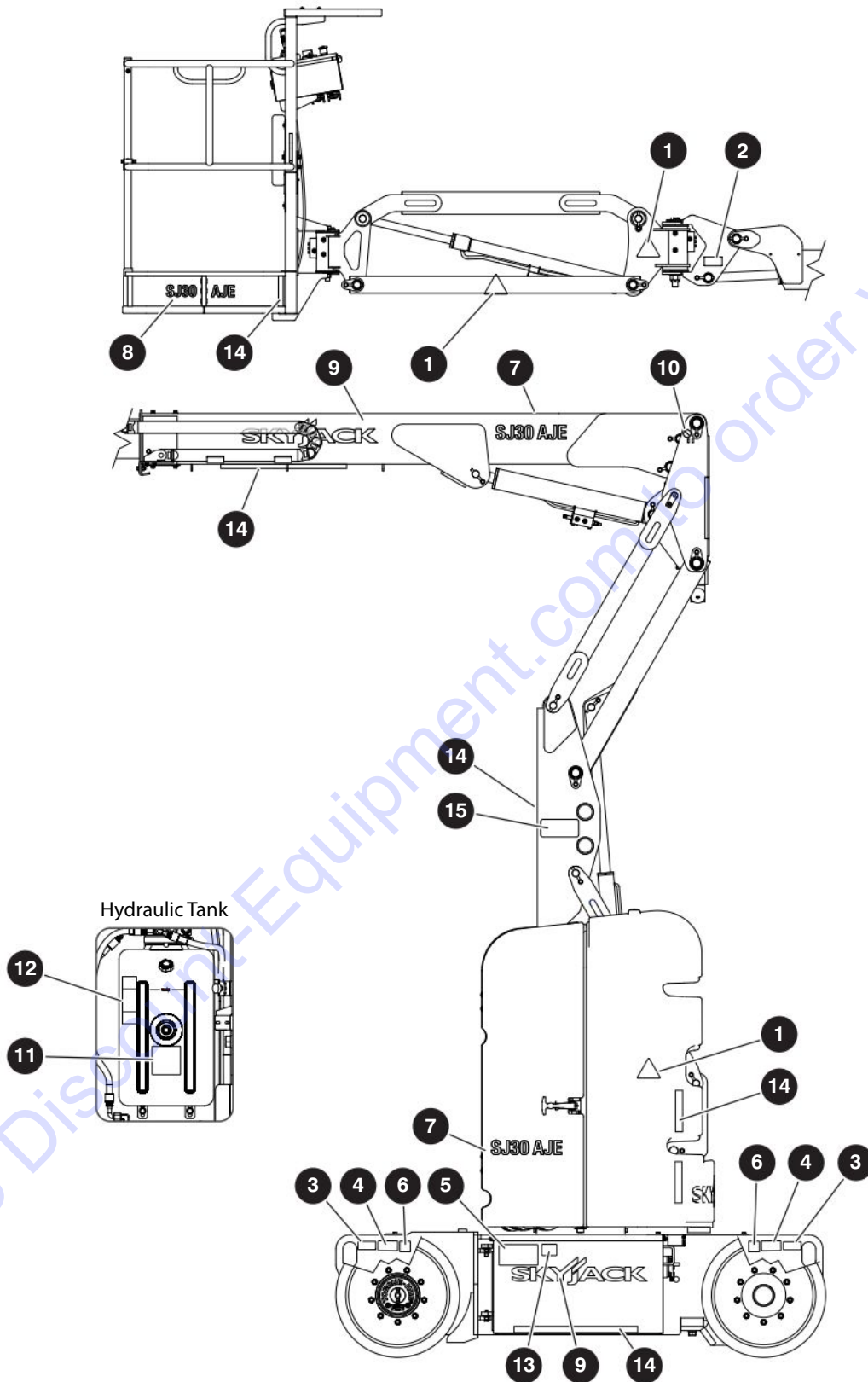

M173204AA_M173205AB_TS

229034ADA

186

SJ30 AJE, SJ30 ARJE

SKYJACK

9.3 Labels - Tank Side

Index No.	Skyjack Part No.	Qty.	Description
1	223640	3	LABEL, Body crush
2	137988	1	LABEL, Crush/pinch point
3	124767	2	LABEL, Tie down
4	124631	2	LABEL, Wheel info
5	223637	1	LABEL, Towing/winchng procedure
6	149824	2	LABEL, Wheel load (3255 kg/7180 lb)
7	172273	2	LABEL, "SJ30 AJE" - white (13")
	172275	2	LABEL, "SJ30 ARJE" - white (14")
8	172274	1	LABEL, "SJ30 AJE" - white (10")
	172276	1	LABEL, "SJ30 ARJE" - white (12")
9	172272	2	LABEL, Skyjack logo - white (24")
10	156613	3	LABEL, Do not alter
11	157143	1	LABEL, Hydraulic oil - standard oil
	172427	1	LABEL, Hydraulic oil - optional bio oil
12	172426	1	LABEL, Hydraulic oil level
13	117023	1	LABEL, CE mark - CE
14	119803	100"	TAPE, Caution (1" wide)
15	172680	1	LABEL, Maintenance stand

9.4 Labels - Front, Back & Top

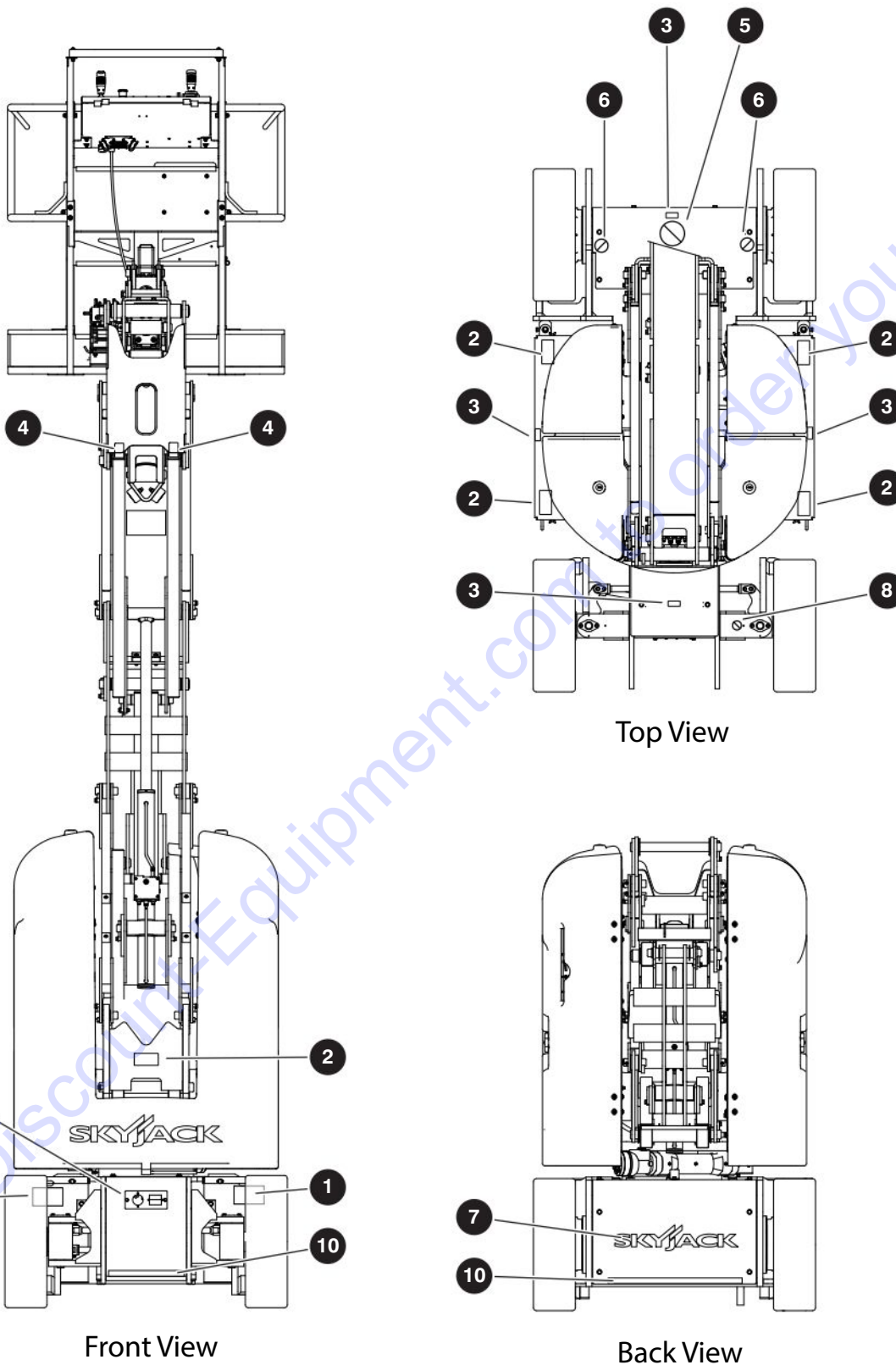

M173204AA_M173205AA_FBT

229034ADA

188

SJ30 AJE, SJ30 ARJE

SKYJACK

9.4 Labels - Front, Back & Top

Index No.	Skyjack Part No.	Qty.	Description
1	172243	2	LABEL, Main disconnect
2	137988	5	LABEL, Crush/pinch point
3	115543	4	LABEL, Warning no step
4	223639	2	LABEL, Crush points (vertical)
5	167996	1	LABEL, Warning 48V
6	170492	2	LABEL, Warning high voltage
7	158554	1	LABEL, Skyjack logo (20")
8	156613	1	LABEL, Do not alter
9	172401	1	LABEL, Battery charging
10	119803	32"	TAPE, Caution (1" wide)

9.5 Labels - Platform

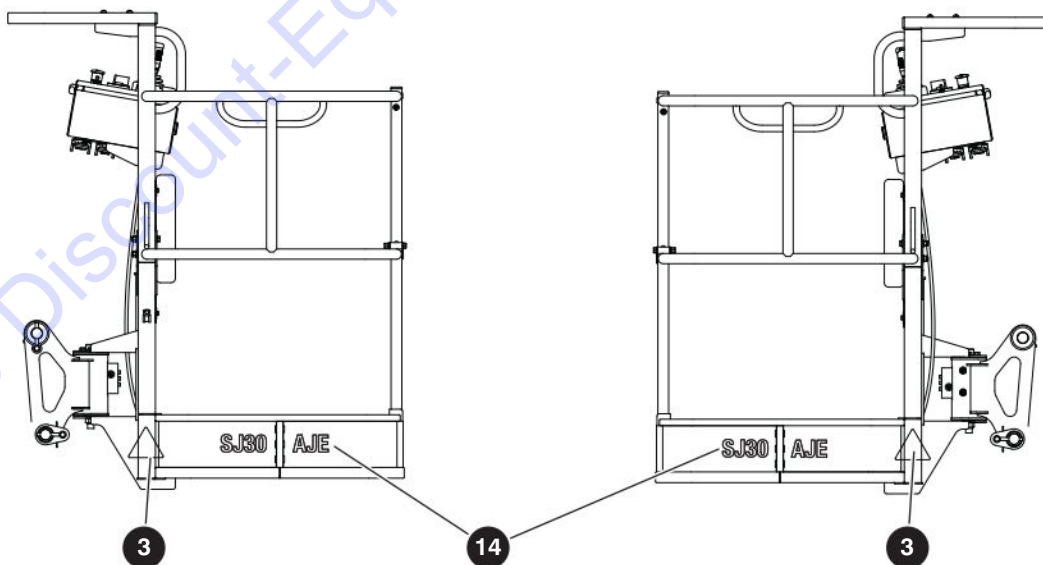
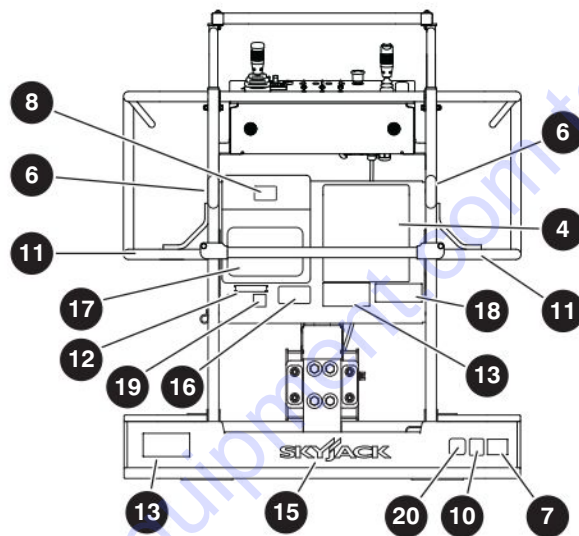
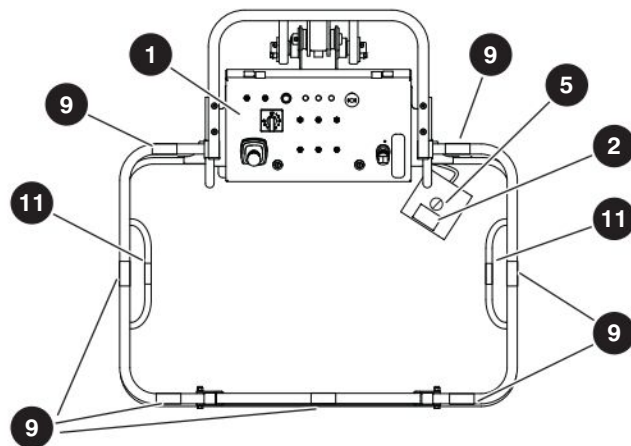

M173204AA_M173205AA_PL

229034ADA

190

SJ30 AJE, SJ30 ARJE

SKYJACK

9.5 Labels - Platform

Index No.	Skyjack Part No.	Qty.	Description
1	173057	1	LABEL, Platform controls
2	143638	1	LABEL, Footswitch enable
3	223640	2	LABEL, Body crush
4	159500	1	LABEL, Warning hazards
5	156613	1	LABEL, Do not alter
6	172639	2	LABEL, Harness anchorage - ANSI/CSA, AS & KC
	172640	2	LABEL, Harness anchorage - CE
7	124362	1	LABEL, Warning do not wear jewelry
8	123628	1	LABEL, Manual box
9	137988	7	LABEL, Crush/pinch point
10	159513	1	LABEL, Daily maintenance checklist
11	115543	6	LABEL, Warning no step
12	138211	1	LABEL, Connect AC supply
13	173149	2	LABEL, Capacity (227 kg / 500 lb / 2 person / 1 person wind)
14	172274	1	LABEL, "SJ30 AJE" - white (10")
	172276	1	LABEL, "SJ30 ARJE" - white (12")
15	163860	1	LABEL, Skyjack logo - white (13")
16	173084	1	LABEL, California proposition 65 - ANSI/CSA
17	161631	1	LABEL, Clearance power lines - AS
	172429	1	LABEL, Quick start - KC
18	147043	1	LABEL, "Click it!" IPAF
19	173202	1	LABEL, Tip over hazard
20	172693	1	LABEL, Non-insulated

9.6 Labels - Hoses - KC

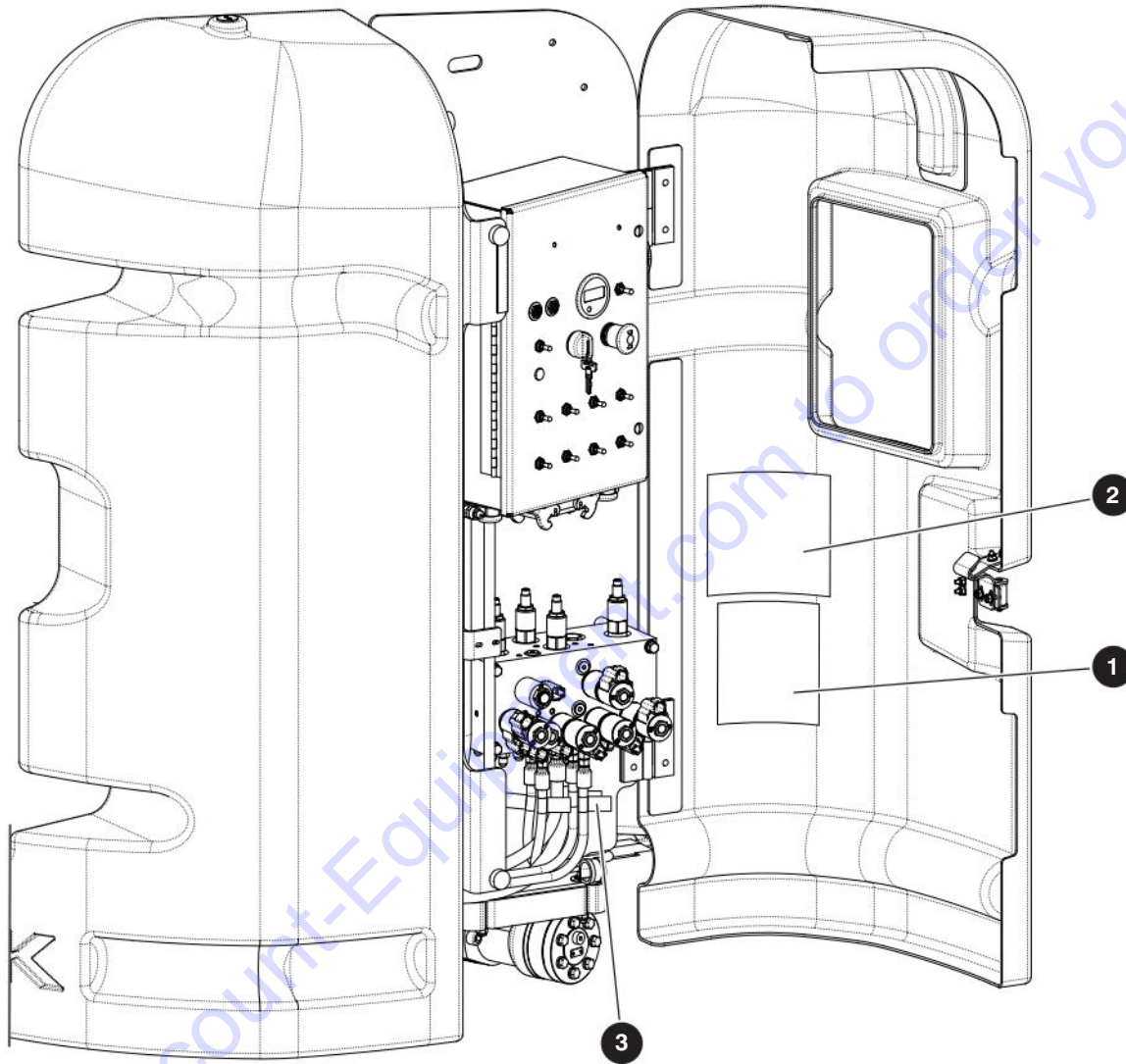

M63237AA

229034ADA

192

SJ30 AJE, SJ30 ARJE

SKYJACK

9.6 Labels - Hoses - KC

Index No.	Skyjack Part No.	Qty.	Description
1	172434	1	LABEL, Hydraulic hoses 1-9 - KC
2	172435	1	LABEL, Hydraulic hoses 10-29 - KC
3	172359	1	LABEL, "1"
	172360	1	LABEL, "2"
	172361	1	LABEL, "3"
	172362	1	LABEL, "4"
	172363	1	LABEL, "5"
	172364	1	LABEL, "6"
	172365	1	LABEL, "7"
	172366	1	LABEL, "8"
	172367	1	LABEL, "9"
	172368	1	LABEL, "10"
	172369	1	LABEL, "11"
	172374	1	LABEL, "12"
	172375	1	LABEL, "13"
	172376	1	LABEL, "14"
	172377	1	LABEL, "15"
	172378	1	LABEL, "16"
	172379	1	LABEL, "17"
	172380	1	LABEL, "18"
	172381	1	LABEL, "19"
	172436	1	LABEL, "20"
	172437	1	LABEL, "21"
	172438	1	LABEL, "22"
	172439	1	LABEL, "23"
	172440	1	LABEL, "24"
	172441	1	LABEL, "25"
	172442	1	LABEL, "26"
	172443	1	LABEL, "27"
	172444	1	LABEL, "28"
	172445	1	LABEL, "29"

PARTS FINDER

**Search Website
by Part Number**



**Search Manual
Library For Parts
Manual & Lookup Part
Numbers – Purchase
or Request Quote**

Search Manuals

Enter your information to help us find the right parts manual for your machine.

* Brand:

* Model:

* Serial:

* Part Number:

SEARCH

**Can't Find Part or
Manual? Request Help
by Manufacturer,
Model & Description**

Parts Order Form

Please fill in the following information to help us find the right part for your machine.

Manufacturer:	<input type="text"/>
Model:	<input type="text"/>
Description:	<input type="text"/>
Part Number:	<input type="text"/>
Quantity:	<input type="text"/>
Notes:	<input type="text"/>

Discount-Equipment.com is your online resource for quality parts & equipment.

Florida: **561-964-4949** Outside Florida TOLL FREE: **877-690-3101**

Need parts?

Click on this link: <http://www.discount-equipment.com/category/5443-parts/> and choose one of the options to help get the right parts and equipment you are looking for. Please have the machine model and serial number available in order to help us get you the correct parts. If you don't find the part on the website or on one of the online manuals, please fill out the request form and one of our experienced staff members will get back to you with a quote for the right part that your machine needs.

We sell worldwide for the brands: Genie, Terex, JLG, MultiQuip, Mikasa, Essick, Whiteman, Mayco, Toro Stone, Diamond Products, Generac Magnum, Airman, Haulotte, Barreto, Power Blanket, Nifty Lift, Atlas Copco, Chicago Pneumatic, Allmand, Miller Curber, Skyjack, Lull, Skytrak, Tsurumi, Husquvarna Target, Stow, Wacker, Sakai, Mi-T-M, Sullair, Basic, Dynapac, MBW, Weber, Bartell, Bennar Newman, Haulotte, Ditch Runner, Menegotti, Morrison, Contec, Buddy, Crown, Edco, Wyco, Bomag, Laymor, EZ Trench, Bil-Jax, F.S. Curtis, Gehl Pavers, Heli, Honda, ICS/PowerGrit, IHI, Partner, Imer, Clipper, MMD, Koshin, Rice, CH&E, General Equipment, Amida, Coleman, NAC, Gradall, Square Shooter, Kent, Stanley, Tamco, Toku, Hatz, Kohler, Robin, Wisconsin, Northrock, Oztec, Toker TK, Rol-Air, APT, Wylie, Ingersoll Rand / Doosan, Innovatech, Con X, Ammann, Mecalac, Makinex, Smith Surface Prep, Small Line, Wanco, Yanmar