



www.Discount-Equipment.com

SKYJACK[™]

OPERATING MANUAL

SJ30 AJE SJ30 ARJE

ARTICULATING BOOMS

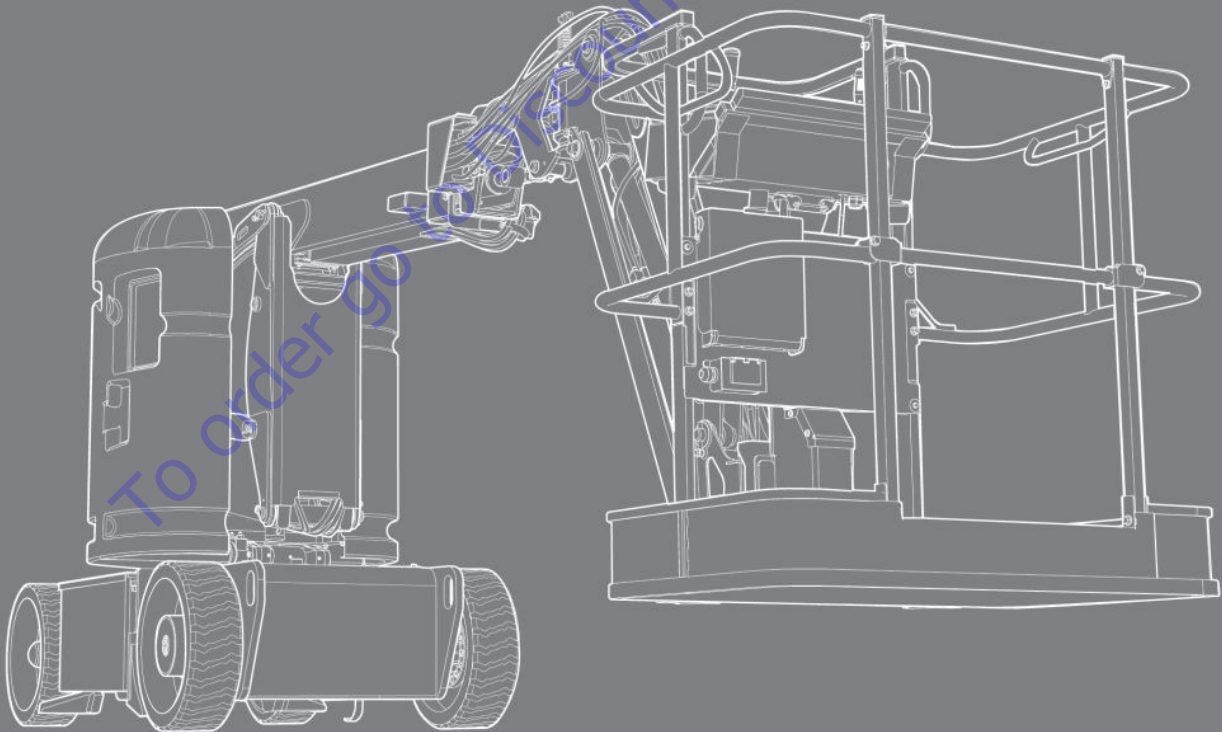

213213ABA

February 2019

ANSI/CSA

TO PURCHASE THIS PRODUCT PLEASE CONTACT US



**Equipment Financing and
Extended Warranties Available**



**Discount-Equipment.com is your online resource for
commercial and industrial quality parts and equipment sales.**

561-964-4949

visit us on line @ www.discount-equipment.com

Select an option below to find your Equipment

Search by Manufacturer

Search by Product Type

Request a Quote

We sell worldwide for the brands: Genie, Terex, JLG, MultiQuip, Mikasa, Essick, Whiteman, Mayco, Toro Stone, Diamond Products, Generac Magnum, Airman, Haulotte, Barreto, Power Blanket, Nifty Lift, Atlas Copco, Chicago Pneumatic, Allmand, Miller Curber, Skyjack, Lull, Skytrak, Tsurumi, Husquvarna Target, Stow, Wacker, Sakai, Mi-T-M, Sullair, Basic, Dynapac, MBW, Weber, Bartell, Bennar Newman, Haulotte, Ditch Runner, Menegotti, Morrison, Contec, Buddy, Crown, Edco, Wyco, Bomag, Laymor, EZ Trench, Bil-Jax, F.S. Curtis, Gehl Pavers, Heli, Honda, ICS/PowerGrit, IHI, Partner, Imer, Clipper, MMD, Koshin, Rice, CH&E, General Equipment, Amida, Coleman, NAC, Gradall, Square Shooter, Kent, Stanley, Tamco, Toku, Hatz, Kohler, Robin, Wisconsin, Northrock, Oztec, Toker TK, Rol-Air, APT, Wylie, Ingersoll Rand / Doosan, Innovatech, Con X, Ammann, Mecalac, Makinex, Smith Surface Prep, Small Line, Wanco, Yanmar

This manual is based on Serial Number(s):

SJ30 AJE & SJ30 ARJE: A300 000 001 & Above

To order go to Discount-Equipment.com

Original instructions in English.

THIS SAFETY ALERT SYMBOL MEANS ATTENTION!



BE ALERT! YOUR SAFETY IS INVOLVED.

The Safety Alert Symbol identifies important safety messages on MEWPs, safety signs in manuals or elsewhere. When you see this symbol, be alert to the possibility of personal injury or death. Follow the instructions in the safety message.

DANGER

DANGER indicates an imminently hazardous situation which, if not avoided, will result in death or serious injury.

WARNING

WARNING indicates a potentially hazardous situation which, if not avoided, could result in death or serious injury.

CAUTION

CAUTION indicates a potentially hazardous situation which, if not avoided, may result in minor or moderate injury. It may also be used to alert against unsafe practices.

IMPORTANT

IMPORTANT indicates a procedure essential for safe operation and which, if not followed, may result in a malfunction or damage to the MEWP.

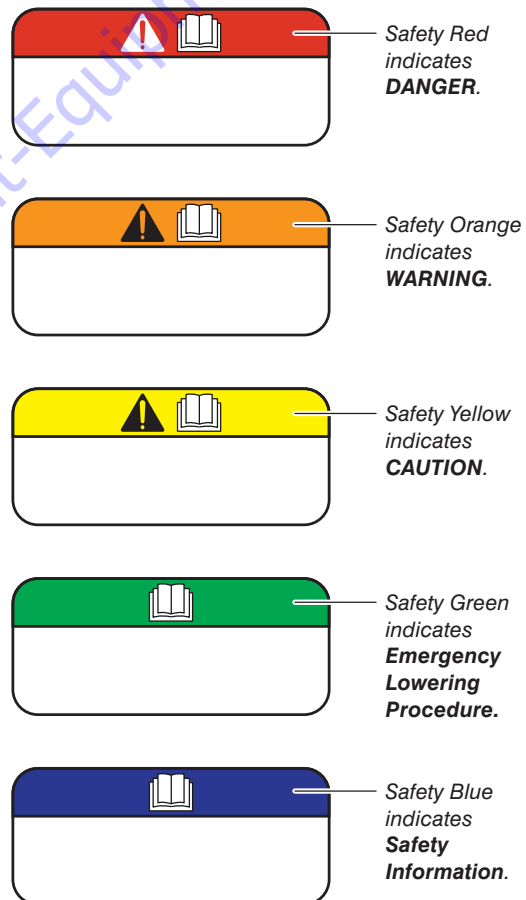

Figure 01 Label legend

Table of Contents

Section 1 – About this Mobile Elevating Work Platform (MEWP)	9
1.1 Read and Heed	9
1.1-1 <i>Mobile elevating work platform (MEWP) definition</i>	9
1.1-2 <i>Purpose of equipment</i>	9
1.1-3 <i>Use of equipment</i>	9
1.1-4 <i>Manual</i>	9
1.1-5 <i>Operator</i>	9
1.1-6 <i>Service policy and warranty</i>	9
1.1-7 <i>Ownership of machine</i>	9
1.1-8 <i>Optional accessories</i>	9
1.1-9 <i>Scope of this manual</i>	10
1.2 Major Assemblies	11
1.2-1 <i>Base</i>	11
1.2-2 <i>Turret</i>	11
1.2-3 <i>Boom assembly</i>	11
1.2-4 <i>Platform</i>	11
1.3 Serial Number Nameplate	13
1.4 Responsibility for Maintenance	13
1.4-1 <i>Operator’s responsibility for maintenance</i>	13
1.4-2 <i>Maintenance and inspection schedule</i>	13
1.4-3 <i>Owner’s inspections</i>	13
Section 2 – Operator Safety	15
2.1 Electrocutation Hazard	15
2.2 Safety Precautions	16
2.3 Fall Protection	18
2.4 Jobsite Inspection	19
Section 3 – Familiarization	21
3.1 Component Identification	22
3.2 Manual Storage Box	23
3.3 Control Functions	23
3.3-1 <i>Main power connectors</i>	23
3.3-2 <i>Footswitch</i>	23
3.3-3 <i>Base control console</i>	24
3.3-4 <i>Platform control console</i>	25
3.4 Features and Devices	27
3.4-1 <i>Lowered travel position and elevated travel position</i>	27

3.4-2	Drive speed	28
3.4-3	Drive direction	28
3.4-4	Tilt switch	28
3.4-5	Function restrictions when tilted	28
3.4-6	Platform load sensing system	28
3.4-7	Overload status	29
3.4-8	Brake system	30
3.4-9	Secondary guarding electrical (SGE)	30
3.4-10	All motion alarm	30
3.4-11	AC outlet on platform	30
3.4-12	Pothole protection	31
3.5	Optional Equipment and Attachments	32
3.5-1	Work light (if equipped)	32
3.5-2	Flashing amber light (if equipped)	32
3.5-3	1000W/120V AC inverter (if equipped)	33
3.5-4	Elevate telematics - access control unit (if equipped)	34
Section 4 – Pre-operation		37
4.1	Operator’s Responsibility	37
4.2	Visual & Daily Maintenance Inspections	38
4.2-1	Labels	38
4.2-2	Electrical	38
4.2-3	Limit switches	38
4.2-4	Hydraulic	38
4.2-5	Base	39
4.2-6	Control compartment	41
4.2-7	Motor/Hydraulic compartment	42
4.2-8	Platform assembly	43
4.2-9	Boom assembly	44
4.2-10	Optional equipment/attachments	45
4.3	Function Tests	46
4.3-1	Testing main power connectors	46
4.3-2	Base control console	47
4.3-3	Testing base emergency stop light and base emergency stop button	47
4.3-4	Testing function enable switch and all boom functions	47
4.3-5	Testing platform self-leveling	48
4.3-6	Testing emergency power	48
4.3-7	Testing base/off/platform switch	49
4.3-8	Platform control console	50
4.3-9	Testing secondary guarding electrical (SGE)	50
4.3-10	Testing platform emergency stop light and platform emergency stop button	52
4.3-11	Testing footswitch	52
4.3-12	Testing steering	52

4.3-13	Testing driving function	52
4.3-14	Testing driving speed	53
4.3-15	Verifying load sensing module self-check	53
4.3-16	Testing emergency power.	54
4.3-17	Testing horn.	54
4.3-18	Testing brakes.	54
4.3-19	Testing manual platform leveling.	54
4.4	Operator's Checklist	55
Section 5 – Operation.		57
5.1	Start Operation	58
5.1-1	Activating base control console	58
5.1-2	Rotating platform using base control console	58
5.1-3	Rotating turret using base control console.	58
5.1-4	Moving jib up and down using base control console	58
5.1-5	Rotating jib using base control console.	58
5.1-6	Moving riser up and down using base control console	58
5.1-7	Raising or lowering main boom using base control console.	59
5.1-8	Extending or retracting fly boom using base control console	59
5.1-9	Leveling platform manually using base control console	59
5.1-10	Operating using emergency power switch at base control console	59
5.1-11	Activating platform control console	59
5.1-12	Driving forward or reverse using platform control console	60
5.1-13	Steering using platform control console.	60
5.1-14	Moving jib up and down using platform control console	60
5.1-15	Rotating jib using platform control console	60
5.1-16	Moving riser up and down using platform control console	60
5.1-17	Extending or retracting fly boom using platform control console.	60
5.1-18	Rotating platform using platform control console.	60
5.1-19	Leveling platform using platform control console	60
5.1-20	Raising or lowering main boom using platform control console	60
5.1-21	Sounding horn	61
5.1-22	Rotating turret using platform control console	61
5.1-23	Operating with emergency power switch at platform control console.	61
5.1-24	Shutdown procedure	61
5.1-25	Inverter (if equipped)	61
Section 6 – Additional Procedures		63
6.1	Emergency Lowering Procedure	63
6.2	Chassis Tilt Recovery	64
6.2-1	Platform uphill	64
6.2-2	Platform downhill	64

6.3	Winching and Towing Procedure	65
6.3-1	<i>Releasing brakes manually</i>	66
6.4	Loading/Unloading	67
6.4-1	<i>Loading and tie-down</i>	67
6.4-2	<i>Lifting</i>	68
6.5	Battery Maintenance	69
6.5-1	<i>Battery service procedure</i>	69
6.5-2	<i>Battery charging operation</i>	69
6.5-3	<i>Charging state LED</i>	70
Section 7 – Technical Drawings and Specifications		71
7.1	Technical Diagrams	72
7.2	Standard and Optional Equipment	76
7.3	Owner’s Annual Inspection Record	77
7.4	Specifications and Features-A	78
7.5	Specifications and Features-B	79
7.6	Tire/Wheel Specifications	79
7.7	Maximum Platform Capacities	79
7.8	Floor Loading Pressure	80
7.8-1	<i>Locally concentrated pressure (LCP)</i>	81
7.8-2	<i>Overall uniform pressure (OUP)</i>	81
Section 8 – Labels		83
8.1	SJ30 AJE & SJ30 ARJE Labels	84
8.1-1	<i>Control side</i>	84
8.1-2	<i>Front side</i>	91
8.1-3	<i>Top view</i>	93
8.1-4	<i>Platform views</i>	94
8.1-5	<i>Motor/Hydraulic side</i>	100
8.1-6	<i>Rear side</i>	105
Section 9 – Unique Skyjack Features		107

Section 1 – About this Mobile Elevating Work Platform (MEWP)

1.1 Read and Heed

Skyjack is continuously improving and expanding product features on its equipment, therefore, specifications and dimensions are subject to change without notice.

1.1-1 Mobile elevating work platform (MEWP) definition

Mobile machine intended for moving persons, tools and material to working positions, consisting of a work platform with controls, an extending structure and a chassis.

1.1-2 Purpose of equipment

The Skyjack SJ30 AJE & SJ30 ARJE Electric Articulating Boom MEWPs are designed to move personnel, tools and materials to working positions.

1.1-3 Use of equipment

The MEWP is a highly maneuverable, mobile work station. Work platform elevation and elevated driving must only be done on a firm, level surface. It can be driven over uneven terrain only when the platform is fully lowered.

1.1-4 Manual

The operating manual is considered a fundamental part of the MEWP. It is a very important way to communicate necessary safety information to users and operators. A complete and legible copy of this manual must be kept in the provided weather-resistant storage compartment on the MEWP at all times.

1.1-5 Operator

The operator must read and completely understand this operating manual, the safety panel label located on the platform, the limitations, operating procedures, operator's responsibility for maintenance and all other warnings and instructions in this manual and on the MEWP.

Compare the labels on the MEWP with the labels found within this manual. If any labels are damaged or missing, replace them immediately.

Only trained and authorized personnel shall be permitted to operate a MEWP.

The operator must be familiar with the employer's work rules and related government regulations and be able to demonstrate the ability to understand and operate this make and model of MEWP in the presence of a qualified/competent person.

1.1-6 Service policy and warranty

Skyjack warrants each new product to be free of defective parts and workmanship for the first 2 years or 3000 hours, whichever occurs first. Any defective part will be replaced or repaired by your local Skyjack dealer at no charge for parts or labor. In addition, all products have a 5 year structural warranty. Contact the Skyjack Service Department for warranty statement extensions or exclusions.

1.1-7 Ownership of machine

Notify Skyjack of machine ownership. If you have sold or transferred any machine, promptly notify Skyjack of new owner's contact information.

1.1-8 Optional accessories

The Skyjack MEWP is designed to accept a variety of optional accessories. These are listed under [Section 7.2](#). Operating instructions for these options (if equipped) are located in [Section 5](#) of this manual.

For non-standard components or systems, contact the Skyjack Service Department.

Include the model and serial number for each applicable MEWP.

About Your Mobile Elevating Work Platform (MEWP) Continued

1.1-9 Scope of this manual

1. This manual applies to the ANSI/SAIA and CSA versions of the Electric Articulating Boom MEWP models listed in [Section 7.2](#).

- Equipment identified with “ANSI” meets the ANSI/SAIA A92.20:2018 standard.
- Equipment identified with “CSA” meets the CSA B354.6:2017 standard.

2. CSA (Canada)

- Operators are required to conform to national, territorial/provincial and local health and safety regulations applicable to the operation of this MEWP.

3. ANSI/SAIA (United States)

- Operators are required by the current ANSI/SAIA A92.22:2018 standards to read and understand their responsibilities in this manual and the manual of responsibilities before they use or operate this MEWP.

To order go to Discount-Equipment.com

1.2 Major Assemblies

The MEWP consists of four major assemblies: the base, turret, boom assembly and platform. Refer to [Figure 02](#).

1.2-1 Base

The base is a rigid, one-piece weldment, which supports two swing out battery trays. The rear axle is electrically motor-driven and has spring-applied, electrically released brakes. The front axle is steerable by a hydraulic cylinder.

1.2-2 Turret

The turret rotates 352 degrees. The turret supports two compartments. One compartment contains the pump/motor unit, hydraulic filter, hydraulic tank and emergency pump unit. The other compartment contains the base control console, main manifold, and function valves. The swing drive is located underneath the turret.

1.2-3 Boom assembly

The boom assembly consists of the riser, telescoping fly and main boom assembly. The riser is mounted on the turret with the main boom, attached to the riser. The riser mechanism uses two double-acting hydraulic cylinders with holding valves to control vertical movement. AJE & ARJE models are equipped with a 124 cm (49 in) jib, controlled by a double-acting hydraulic cylinder.

1.2-4 Platform

The platform is constructed of a skid-resistant deck surface allowing visibility through the deck and a 110 cm (43 in) high tubular steel railing system with mid rails and 15 cm (6 in) toe boards. The platform can be entered through a drop bar, located opposite the control box side. The platform can be rotated in either direction. An AC outlet is also located on the platform.

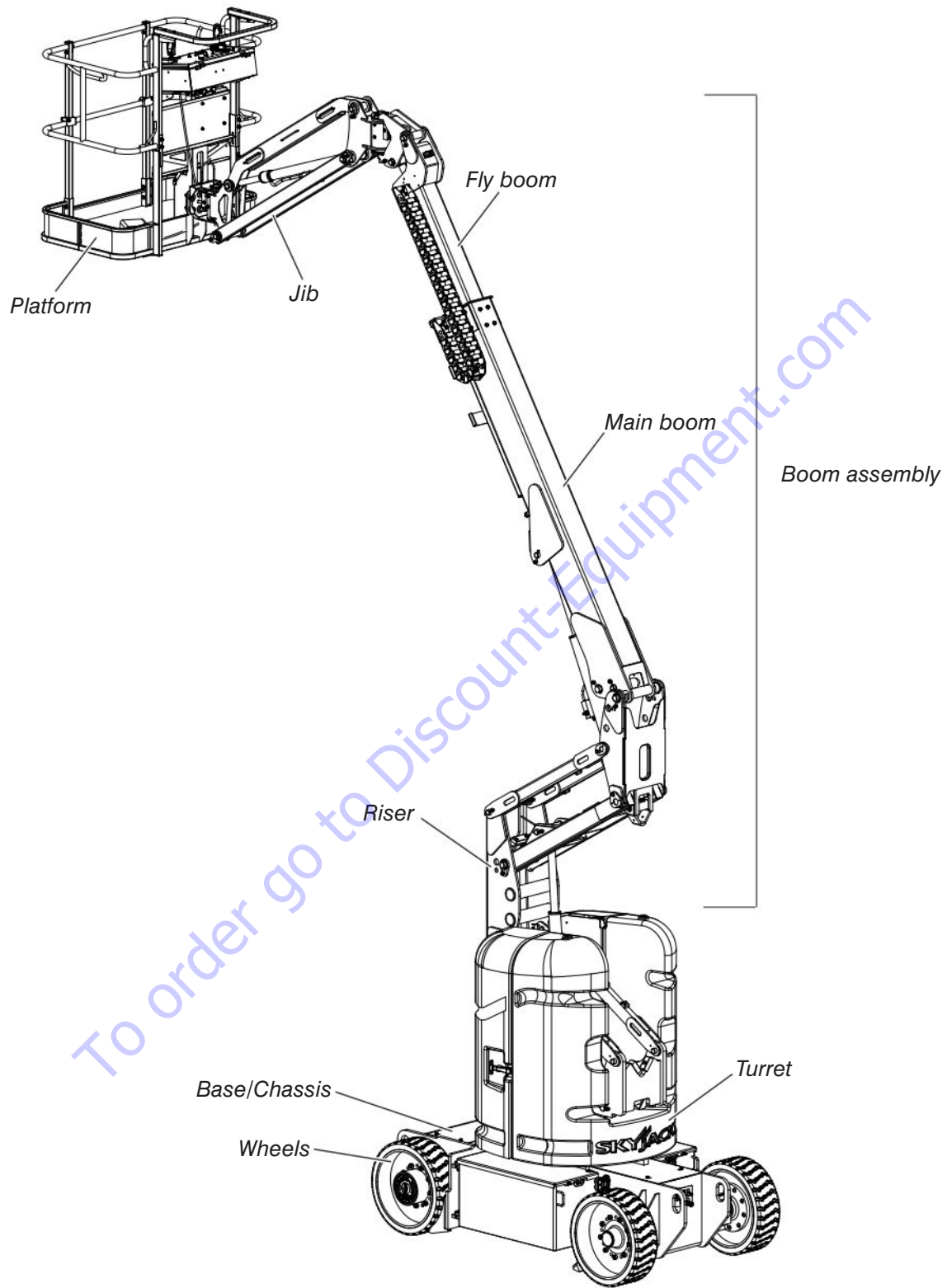

Figure 02 Major assemblies

1.3 Serial Number Nameplate

The serial number nameplate (refer to [Section 8](#)), located at the rear of the MEWP, lists the following:

- Model number
- Type
- Group
- Serial number
- Indoor use and outdoor use
- Capacity and maximum number of persons
- Maximum work platform height
- Maximum wind speed
- Maximum manual force
- Machine weight
- Voltage
- Maximum incline
- System pressure
- Model year
- Year of manufacture

1.4 Responsibility for Maintenance

1.4-1 Operator's responsibility for maintenance

WARNING

Maintenance must be performed by trained and qualified/competent personnel who are familiar with mechanical procedures.

Death or serious injury could result from the use of a MEWP that is not properly maintained or kept in good working condition.

The operator must be sure that the MEWP has been properly maintained and inspected before using it.

The operator must perform all the daily inspections and function tests found in [Section 4.4](#), even if the operator is not directly responsible for the maintenance of this MEWP.

1.4-2 Maintenance and inspection schedule

Refer to service manual for frequent/periodic (every 3 months or 150 hours) and annual inspection details.

The actual operating environment of the MEWP may affect the maintenance schedule.

WARNING

Use original or manufacturer-approved parts and components for the MEWP.

NOTE

Refer to Skyjack's website www.skyjack.com for the latest service bulletins prior to performing frequent/periodic or annual inspections.

1.4-3 Owner's inspections

It is the responsibility of the owner to arrange daily, quarterly (or 150 hours) and annual inspections of the MEWP. Refer to the service manual for recommended maintenance and inspection areas and intervals. A record of annual inspection is kept on a label located close to the base control console on the cowling (refer to [Section 7.3](#)).

Section 2 – Operator Safety

⚠ WARNING

Failure to comply with your required responsibilities in the use and operation of the MEWP could result in death or serious injury!

A study conducted by St. Paul Travelers showed that most accidents are caused by the failure of the operator to follow simple and fundamental safety rules and precautions.

You, as a careful operator, are the best insurance against an accident. Therefore, proper usage of this MEWP is mandatory. The following pages of this manual should be read and understood completely before operating the MEWP.

Common sense dictates the use of protective clothing when working on or near machinery. Use appropriate safety devices to protect your eyes, ears, hands, feet and body.

Any modifications from the original design are strictly forbidden without written permission from Skyjack.

2.1 Electrocutation Hazard

This MEWP is not electrically insulated. Use extreme caution around high-voltage overhead power lines and parts. Maintain a Minimum Safe Approach Distance (MSAD) of 10 ft from sources of power (refer to [Figure 03](#)). If the work requires to be closer than 10 ft, stop and consult a qualified person with respect to electrical transmission and distribution to have appropriate measures taken.

Adhere to all the federal/national, state/provincial, or local safety regulations for your own protection.

No part of the MEWP or payload must be brought closer to any energized overhead electrical conductor with a nominal phase voltage rating as specified in [Figure 03](#).

Minimum Safe Approach Distance	
Voltage Range	Minimum Safe Approach Distance
≤ 50 KVA	3 m (10 ft)
> 50 KVA	Stop and consult a qualified person with respect to electrical transmission and distribution to have appropriate measures taken
FAILURE TO AVOID THIS HAZARD WILL RESULT IN DEATH OR SERIOUS INJURY	

Figure 03 Minimum safe approach distance

⚠ DANGER

Never approach any power line with any part of the MEWP. Use extreme caution--contact from any power line can cause serious injury or death.

IMPORTANT

Always assume the electrical power sources and overhead lines are energized.



MAINTAIN a minimum safe approach distance from sources of high-voltage power.



DO NOT operate the MEWP during lightning or storms. Take into account the effects of weather (e.g., wind, rain and snow) on the safe operation of the MEWP.

⚠ WARNING

Do not use the MEWP as a ground for welding.

2.2 Safety Precautions

Know and understand the safety precautions before going on to next section.

WARNING

Failure to heed the following safety precautions could result in tip over, falling, crushing, or other hazards leading to death or serious injury.

KNOW all national, state or territorial/provincial and local rules which apply to your MEWP and jobsite.

DISCONNECT and lock out main power connector on either the left or right side of the MEWP when leaving the MEWP unattended to prevent unauthorized use.

WEAR all the protective clothing and personal safety devices issued to you or called for by job conditions.



DO NOT wear loose clothing, dangling neckties, scarves, rings, wristwatches or other jewelry while operating this MEWP.



AVOID entanglement with ropes, cords or hoses.



AVOID falling. Stay within the boundaries of the guardrails. Maintain firm footing on the platform floor at all times while working thereon.

ENSURE all occupants wear personal fall protection equipment.



DO NOT raise the MEWP or operate elevated in windy or gusty conditions that exceed the limits specified in [Section 7.7](#).



DO NOT increase the lateral surface area of the platform. Increasing the area exposed to the wind will decrease MEWP stability. Avoid tenting.

DO NOT elevate the MEWP if it is not on a firm, level surface.

ENSURE ground condition assessment considers subsurface voids such as cellars, basements, culverts, and pipes.



DO NOT drive elevated near depressions or holes of any type, loading docks, debris, drop-offs and surfaces that may affect the stability of the MEWP.



DO NOT elevate or drive elevated on a slope. Elevated driving must be done on a firm, level surface.



If operation in areas with holes or drop-offs is absolutely necessary, elevated driving shall not be allowed. Position the MEWP horizontally only with the platform fully lowered. After ensuring that all 4 wheels or outriggers (if equipped) have contact with a firm, level surface, the MEWP can be elevated. After elevation, the drive function must not be activated.



DO NOT drive elevated on a soft or uneven surface.



DO NOT ascend or descend a grade steeper than 35%. Boom elevated driving must only be done on firm, level surfaces.



DO NOT operate an MEWP that has ladders, scaffolding or other devices mounted on it to increase its size or work height. It is prohibited.



DO NOT exert horizontal (manual) force on MEWP that exceeds the limits specified in [Section 7.7](#).



DO NOT use the MEWP as a crane. It is prohibited.



DO NOT climb on boom arm assembly. It is prohibited.



DO NOT sit, stand or climb on the guardrails. It is prohibited.



AVOID overhead obstructions. Be aware of overhead obstructions or other possible hazards around MEWP when lifting or driving.



AVOID crushing hazards. Be aware of crushing hazards when lifting or driving. Keep all body parts inside the MEWP.



BE AWARE of blind spots when operating the MEWP. **ENSURE** that there are no personnel or obstructions in the path of travel, including blind spots.



DO NOT lower the platform unless the area below is clear of personnel and obstructions.



DO NOT use boom to push, pull other objects or to lift the chassis.



DO NOT raise the MEWP while it is on a truck, forklift or other device or vehicle.

STUNT driving and horseplay are prohibited.



DO NOT use with improperly inflated/damaged tires or wheels. Refer to [Section 4.2-5: Wheel/Tire Assembly](#).



DO NOT alter or disable limit switches or other safety devices.

DO NOT use the MEWP without guardrails, locking pins and the entry gate/drop bar in place.



DO NOT exceed the rated capacity of the MEWP.



DO NOT distribute load unevenly.



DO NOT use the MEWP under influence of alcohol or drugs, or if operator's performance is impaired by a medical condition, the influence of prescription or over the counter drugs, or fatigue.

DO NOT attempt to free a snagged platform with lower controls until personnel are removed from the platform.

DO NOT position the MEWP against another object to steady the platform.

DO NOT operate on slippery surfaces not capable of providing adequate traction to stop, drive or steer the MEWP.

DO NOT place materials on the guardrails or materials that exceed the confines of the guardrails unless approved by Skyjack.



DO NOT operate if MEWP is not working properly or if any parts are damaged or worn.



DO NOT leave MEWP unattended with key in key switch.

2.3 Fall Protection

All occupants of this machine must wear Personal Fall Protection Equipment (PFPE) at all times. The guardrail system of the MEWP is the primary fall protection for the occupant(s) of the machine.

⚠ WARNING

Failure to wear personal fall protection equipment may result in death or serious injury.

Use Personal Fall Protection Equipment with a short lanyard in order to minimize the risk of ejection of an occupant from the platform.

All personal fall protection equipment must comply with applicable governmental regulations and must be inspected and used in accordance with the manufacturer's recommendations.

All personal fall protection equipment must be attached only to approved anchorage points within the platform of the MEWP.

WARNING

Entering and exiting the MEWP should only be done using the three points of contact.

- Use only equipped access openings.
- Enter and exit only when the MEWP is in the fully retracted position.

- Use three points of contact to enter and exit the platform. Enter and exit the platform from the ground only. Face the MEWP when entering or exiting the platform.
- Three points of contact means that two hands and one foot or one hand and two feet are in contact with the MEWP or the ground at all times during entering and exiting.

WARNING

An operator should not use any MEWP that:

- does not appear to be working properly.
- has been damaged or appears to have worn or missing parts.
- has alterations or modifications not approved by the manufacturer.
- has safety devices which have been altered or disabled.
- has been tagged or locked out for non-use or repair.

Failure to avoid these hazards could result in death or serious injury.

2.4 Jobsite Inspection

Ensure operating environment (i.e. operating temperature, Electromagnetic Compatibility (EMC), and hazardous location rating) is suitable to MEWP specifications (refer to [Section 7.5](#)).

Be sure to follow all local, provincial/territorial/state and national regulations related to operating the MEWP. Do not use MEWP in hazardous locations.

Perform a thorough jobsite inspection prior to operating the MEWP to identify potential hazards in your work area.

Be aware of moving equipment in the area. Take appropriate actions to avoid collision.

It is the responsibility of the operator to perform a job site inspection and avoid the following hazardous situations:

- holes or drop-offs
- slopes
- ditches or soft fills
- floor obstructions, bumps or debris
- overhead obstructions
- electrical cords, hoses and high voltage conductors
- hazardous locations
- inadequate surface support to withstand all load forces imposed by the MEWP (refer to [Section 7.8](#))
- wind and weather conditions
- the presence of unauthorized personnel
- the presence of other mobile equipment
- traffic hazards
- other possible unsafe conditions

Section 3 – Familiarization

WARNING

MEWP Familiarization should be given only to individuals who are **QUALIFIED/COMPETENT** and **TRAINED** to operate a MEWP.

WARNING

Do not operate this MEWP without proper authorization and training. Failure to avoid this hazard could result in death or serious injury.

WARNING

It is the responsibility of the operator to read, completely understand and follow all instructions and warnings contained in this operating manual and on the MEWP.

Read and completely understand the operating manual and all warnings and instruction labels (refer to [Section 8](#)) on the MEWP.

Before operating this MEWP, perform the following tasks:

1. Visual and daily maintenance inspections (refer to [Section 4.2](#))
2. Function tests (refer to [Section 4.3](#))
3. Jobsite inspection (refer to [Section 2.4](#)).

3.1 Component Identification

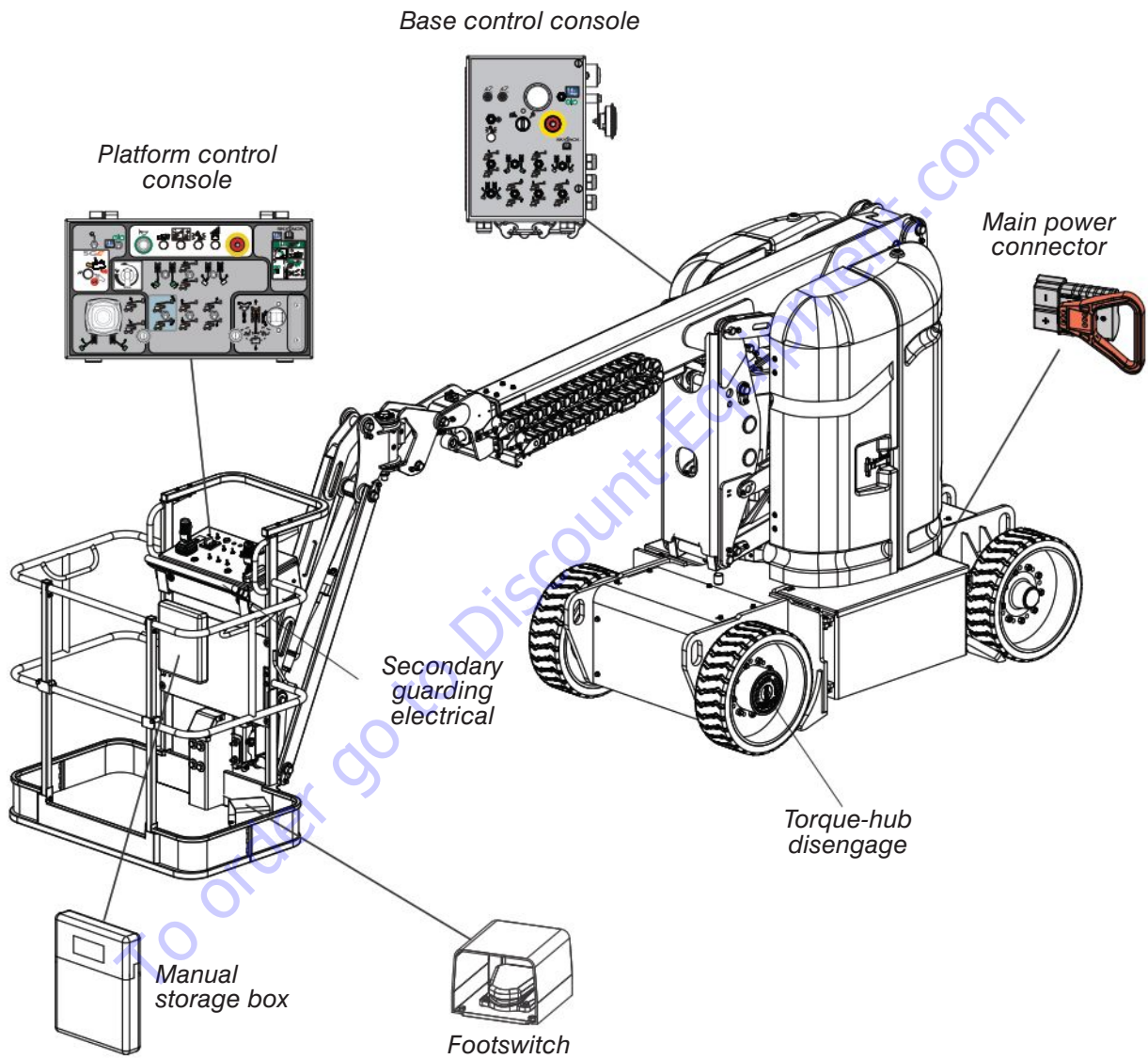

3.2 Manual Storage Box

This weather-resistant box is mounted under the control console on the platform. It contains the operating manual and other important documents. The operating manual for this make and model of MEWP must remain with the MEWP and should be stored in this box.

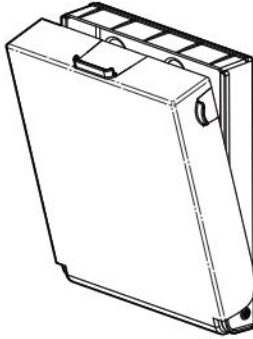

Figure 04 Manual storage box

3.3-2 Footswitch

The footswitch is located on the floor of the platform. When depressed and held, it enables controls on platform control console.

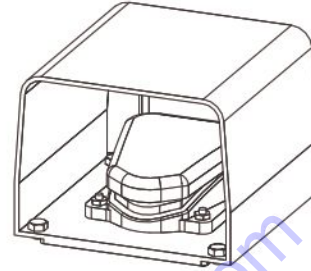

Figure 06 Footswitch

NOTE

The footswitch is equipped with a 7-second anti-tiedown feature that deactivates footswitch when operator depresses it for 7 seconds without activating any function.

3.3 Control Functions

3.3-1 Main power connectors

The two connectors are located on both the left and right sides of the MEWP.

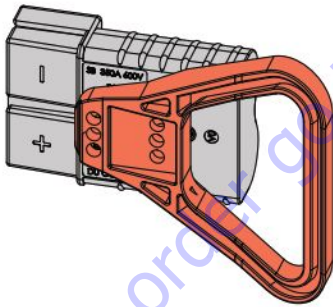

Figure 05 Main power connector

Main power connector - This connector, when disconnected and locked out, disconnects power to all circuits. Connector must be plugged in to base to operate any circuit. Disconnect and lock out when transporting MEWP.

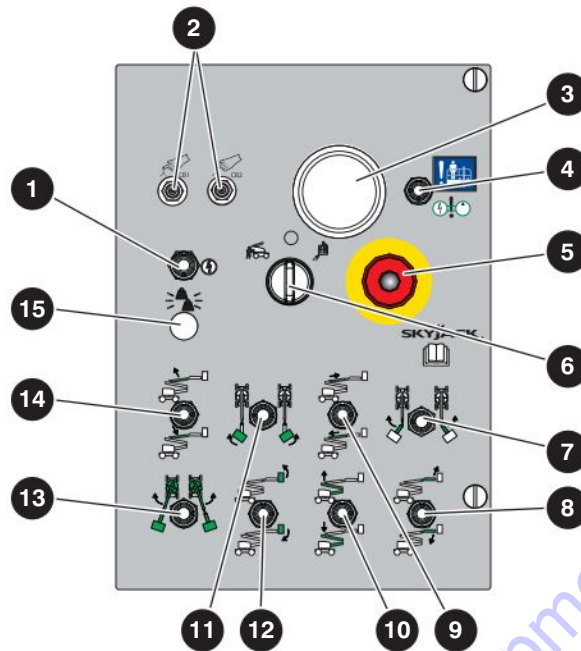

Figure 07 Base control console

3.3-3 Base control console

This control console is located in the panel mounted in the control compartment. It has the following controls:

- 1 **Function enable switch** - This momentary switch, when held in function enable position, allows base control functions to operate.
- 2 **Circuit breakers** - In the event of a power overload or positive circuit grounding, the circuit breaker pops out. Push breaker back in to reset.
- 3 **Hourmeter** - The display shows accumulated operating time, battery level and error codes. Refer to service manual for error codes.
- 4 **Emergency power switch** - This switch, when held in emergency power position, allows base control functions to operate using emergency power unit.
- 5 **Emergency stop button** - This red “mushroom-head” pushbutton disconnects power to control circuit.
- 6 **Base/off/platform key switch** - This three-way selector switch allows operator to activate base control console, turn off power to MEWP, or activate platform control console.
- 7 **Jib rotation switch (if equipped)** - This switch controls left or right rotation of jib.
- 8 **Jib up/down switch** - This switch controls up or down movement of jib.
- 9 **Boom extend/retract switch** - This switch controls extension or retraction of fly boom.
- 10 **Riser raise/lower switch** - This switch controls raising or lowering of riser.
- 11 **Platform rotation switch** - This switch controls left or right rotation of platform.
- 12 **Platform leveling override switch** - This switch overrides automatic leveling of platform and controls tilting up or tilting down of platform.
- 13 **Turret rotation switch** - This switch controls left or right rotation of turret.
- 14 **Boom raise/lower switch** - This switch controls raising or lowering of main boom.
- 15 **Overload light** - This red light indicates overload status. Refer to [Section 3.4-7](#).

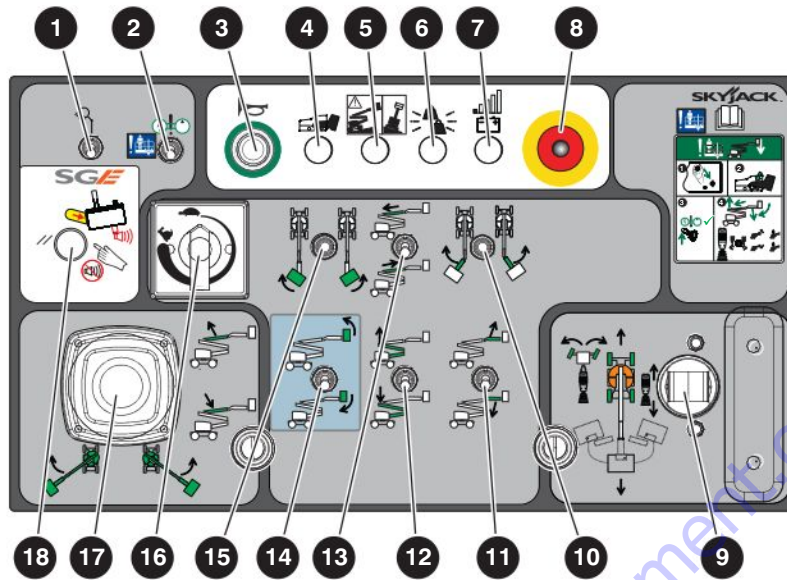

Figure 08 Platform control console

3.3-4 Platform control console

This control console is mounted at front guardrail of the platform. It has the following controls:

- 1 **Work light switch (if equipped)** - This switch turns on work light.
- 2 **Emergency power unit** - This switch enables emergency power unit.
- 3 **Horn pushbutton** - This pushbutton sounds an automotive-type horn.
- 4 **Footswitch indicator light** - This light illuminates when footswitch is depressed. A 7-second anti-tiedown feature deactivates footswitch when operator depresses it for 7 seconds without activating any function.
- 5 **Chassis tilt indicator light** - This light illuminates when the MEWP chassis is at an inclination that activates the tilt sensor.

WARNING

When tilt settings are exceeded, causing the alarm to sound and the light to illuminate, the platform should be lowered and retracted immediately. Refer to [Section 6.2](#) for instructions on how to recover from an inclined position.

NOTE

- If the MEWP becomes tilted while elevated, causing the alarm to sound and the light to illuminate, drive functions will be disabled.
 - If the MEWP is tilted while in the lowered travel position, movement of the fly boom extend, riser up, or main boom into the elevated position will be stopped at the limits of the lowered travel position. The alarm will sound and the light will illuminate. Further fly boom extension, riser up, or main boom rising will be disabled.
 - Resetting power to the controls (e.g. e-stop depressed then pulled out) when the MEWP is tilted and at the limits of the lowered travel position will cause the MEWP to be considered tilted while elevated.
- 6 **Overload light** - This red light indicates overload status. Refer to [Section 3.4-7](#).
 - 7 **Battery level indicator light** - This light illuminates when the battery level is low and the batteries require charging. Refer to [Section 6.5](#) for instructions on how to charge the batteries.

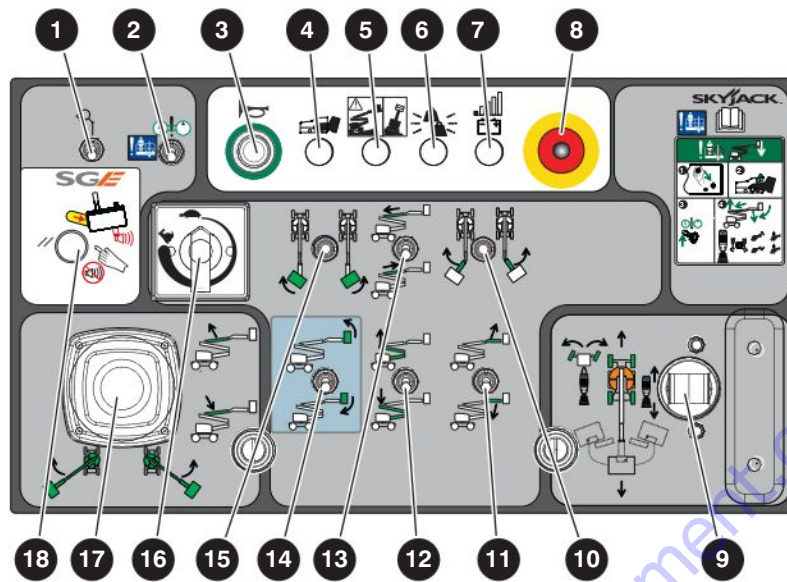

Figure 08 Platform control console

- 8 Emergency stop button/Operation light** - This button, when depressed, disconnects power to the control circuit. The operation light indicates upper control availability. It glows when both emergency stop buttons on the platform control console and the base control console are pulled out.
- 9 Drive/Steer controller** - This single-axis lever controls driving forward or backward. The rocker switch controls steering left or right. Internal springs return the lever to neutral when released.
- 10 Jib rotation switch (if equipped)** - This switch controls left or right rotation of jib.
- 11 Jib up/down switch** - This switch controls up or down movement of jib.
- 12 Riser raise/lower switch** - This switch controls raising or lowering of riser.
- 13 Boom extend/retract switch** - This switch controls extension or retraction of fly boom.
- 14 Platform leveling override switch** - This switch overrides automatic leveling of platform and controls tilting up or tilting down of platform.
- 15 Platform rotation switch** - This switch controls left or right rotation of platform.
- 16 Function speed adjuster dial** - This variable speed adjuster controls speed of fly boom extension/retraction, jib raising/lowering and platform rotation movements. This is used with switches 10, 11, 12, 13, 14 and 15.
- 17 Boom/Turret controller** - This dual-axis lever controls raising or lowering of main boom or rotating left or right of turret.
- 18 Secondary guarding electrical (SGE) reset button** - This button, when depressed, shuts off the audible/visual alarm from the SGE.

CAUTION

The forward direction of travel will be in the general direction the counterweight is facing while reverse will be the opposite. Care should be taken to confirm the counterweight orientation prior to activating any drive/steer functions.

3.4 Features and Devices

3.4-1 Lowered travel position and elevated travel position

Available MEWP functions depend upon a combination of machine configuration (lowered travel position/ elevated travel position), chassis tilt, and platform load.

The MEWP is in the lowered travel position if it is in ALL of the positions shown in *Figure 09*.

The MEWP is in the elevated travel position if it is in ANY of the positions shown in *Figure 10*.

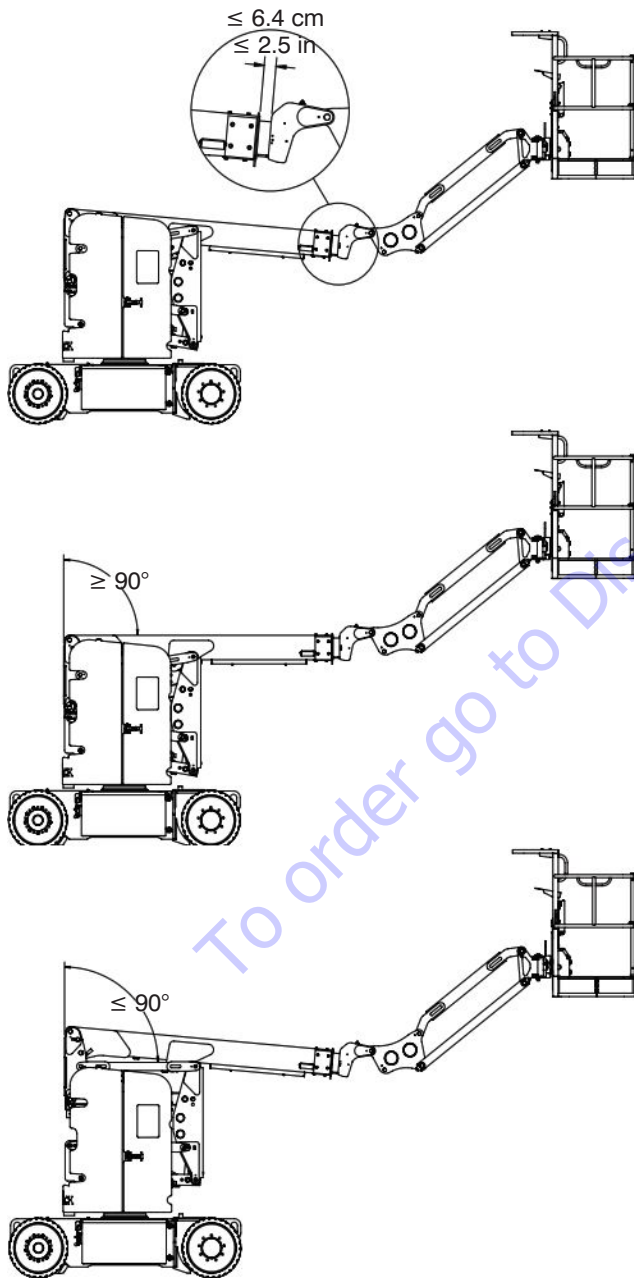

Figure 09 Lowered travel position

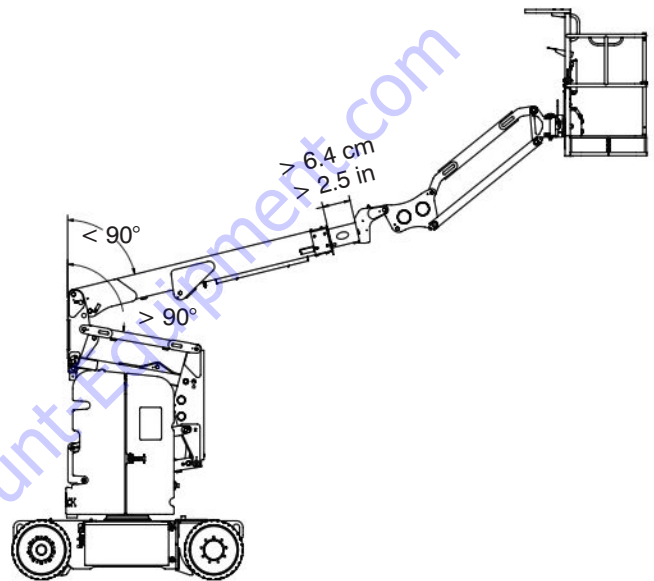

Figure 10 Elevated travel position (any of the boom positions shown)

3.4-2 Drive speed

The drive speed depends upon the machine configuration (lowered travel position/elevated travel position). When the MEWP is in the elevated travel position, the maximum achievable drive speed should be significantly less than the Lowered Travel Position drive speed. Refer to [Section 7.4](#).

3.4-3 Drive direction

The drive function operates in accordance with the general orientation of the turret's counterweight over the chassis (i.e. joystick forward means counterweight is facing forward). Therefore, the MEWP will move in the general direction of the joystick's movement.

3.4-4 Tilt switch

The tilt switch is located within the base control console. When the MEWP is on a slope greater than a predetermined limit, an audible alarm sounds, a visual indicator illuminates, and boom movement or drive functions are disabled (refer to [Section 3.4-5](#)).

WARNING

When tilt settings are exceeded, causing the alarm to sound and the light to illuminate, the platform should be lowered and retracted immediately. Refer to [Section 6.2](#) for instructions on how to recover from an inclined position.

NOTE

Resetting power to the controls (e.g. e-stop depressed then pulled out) when the MEWP is tilted and at the limits of the lowered travel position will cause the MEWP to be considered tilted while elevated.

3.4-5 Function restrictions when tilted

Mode/Condition	Indicator Light	Audible Alarm	Restrictions	Emergency Power (Platform)	Emergency Power (Base)
Lowered travel position, tilted	Disabled	Disabled	No restriction	Enabled	Enabled
In lowered travel position, tilted, moving into elevated travel position (at the limits of the lowered travel position)	Enabled	Enabled	Boom Extension, Boom Up, and Riser Up disabled	Enabled	Enabled
Elevated travel position	Enabled	Enabled	Drive disabled	Enabled	Enabled

1254AC

3.4-6 Platform load sensing system

The platform load sensing system indicates when the load is approaching overload status (refer to [Section 3.4-7](#)).

If the platform is overloaded while in elevated travel position, the load sensing system will disable functions as per [Section 3.4-7](#) and signal the operator with an indicator light and an audible alarm.

If the platform is overloaded while in lowered travel position, the load sensing system will signal the operator with an indicator light and an audible alarm but will not disable any functions (refer to [Section 3.4-7](#)).

WARNING

If the platform is overloaded due to contact with an overhead obstruction, do one of the following:

- Remove the obstruction from the platform, then after a four-second delay normal functions can be resumed.
- Use the emergency power unit to release the platform from the obstruction.
- Do not attempt to free a snagged platform with lower controls until personnel are removed from the platform.

3.4-7 Overload status

Mode/Condition	Indicator Light	Audible Alarm	Drive Functions	Powered Boom Functions (Platform & Base)	Emergency Power (Platform)	Emergency Power (Base)
93-99% of platform capacity	On	Off	Enabled	Enabled	Enabled	Enabled
Lowered Travel Position, \geq 100% of platform capacity	Flashing	Pulsing	Enabled	Enabled	Enabled	Enabled
Elevated Travel Position, \geq 100% of platform capacity	Flashing	Pulsing	Disabled	Disabled	Enabled	Enabled

1702AA

WARNING

If the platform load sensing system is in fault mode (overload light flashes), do the following:

- Ensure platform is level and there are no obstructions contacting the platform.

If the platform load sensing system remains in fault mode, the emergency power unit may be used to lower the platform. Contact a qualified/competent person for repairs.

To order go to Discount-Equipment.com

3.4-8 Brake system

The brake system is integrated into the torque hub. The torque hub disengage is located at the rear of the base. The brakes must be manually disengaged before winching or towing. Refer to [Section 6.3-1](#) for procedure on how to release brakes manually.

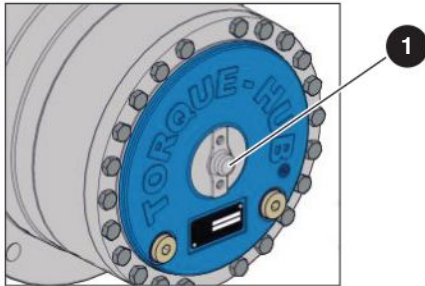

Figure 11 Torque-hub disengage

- 1 **Disengage cap** - This device is used to manually disengage the brakes.

3.4-9 Secondary guarding electrical (SGE)

The purpose of this device is to prevent sustained involuntary operation of the lift, which may result from accidental contact with the platform controls, and to activate an alarm (audible/visual) to alert others of the event.

WARNING

This device will not prevent collision or eliminate the potential for injuries resulting from a collision.

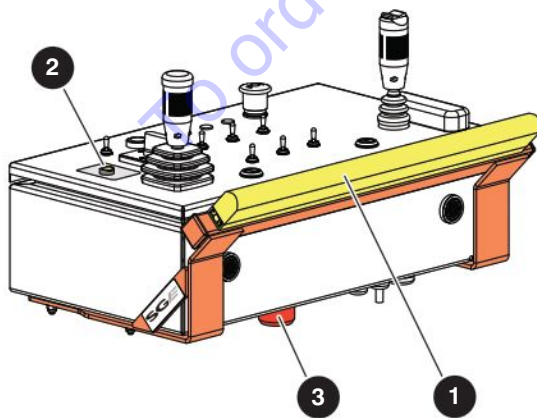

Figure 12 Secondary guarding electrical (SGE)

- 1 **Sensor bar** - This bar is located in front of the platform control console. When pressure is applied to the sensor bar, it interrupts/halts all functions.
- 2 **Reset button** - This button is located on the top left corner of the platform control console. It lights up when pressure is applied to the sensor bar for more than 1 second. When depressed, it shuts off the audible/visual alarm.
- 3 **Audible/visual alarm** - This alarm is located on the underside of the platform control console. It activates when pressure is applied to the sensor bar.

SGE operation

1. When pressure is applied to the sensor bar for less than 1 second, the audible/visual alarm will activate while the bar is being pressed, interrupting all functions. The audible/visual alarm will turn off after the sensor bar is released, and functions will resume.
2. When pressure is applied to the sensor bar for more than 1 second, the audible/visual alarm will activate. All functions will be halted and the reset button will illuminate.
3. After removing pressure from the bar, press the reset button to shut off the audible/visual alarm and resume all functions.

3.4-10 All motion alarm

This alarm produces an audible sound when the footswitch is activated. On MEWPs with certain options, a flashing amber light will accompany this alarm.

3.4-11 AC outlet on platform

This outlet is a source of AC power on the platform. The outlet is located on the right side of platform control console and the plug is located at the middle rear section of the turret.

3.4-12 Pothole protection

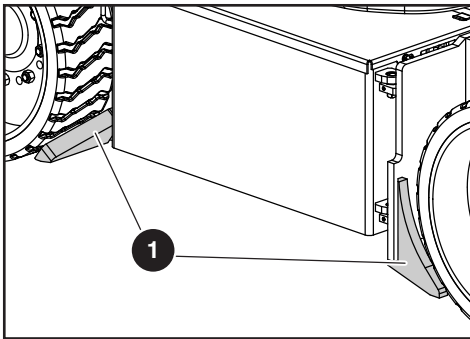

Figure 13 Pothole protection

- ① **Pothole protection** - These steel weldments reduce ground clearance and assist in the stability of an elevated MEWP in the event of the MEWP encountering a “drop-off” or “pothole.”

⚠ WARNING

Do not drive elevated in areas where electrical cords or debris are in the path of travel.

To order go to Discount-Equipment.com

3.5 Optional Equipment and Attachments

CAUTION

Skyjack approved modifications/attachments may affect MEWP specifications. Refer to any applicable instructions and/or labels.

NOTE

Refer to optional equipment or attachment labels for actual weight. This weight must be included when determining the total load on the platform, including personnel and other materials.

NOTE

The combined weight of the attachment, panels, occupants and tools should not exceed the rated platform capacity.

3.5-1 Work light (if equipped)

The work light assembly is mounted on top of the railings of the platform.

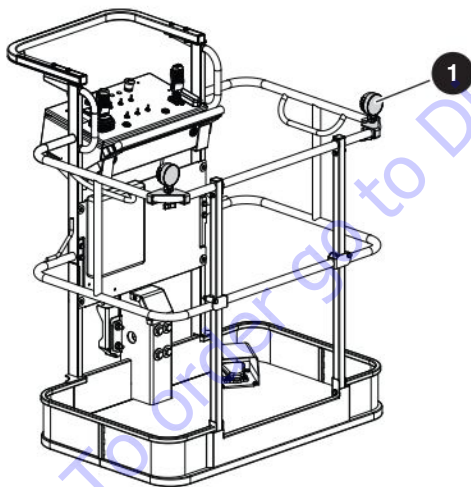

Figure 14 Work light

NOTE

Ensure base emergency stop button is pulled out and platform control console has been activated using base/off/platform key switch.

- 1 **Work light** - This light turns on when the work light switch is activated.

WARNING

Work lights are not intended to replace the ambient lighting required to navigate and operate this MEWP.

3.5-2 Flashing amber light (if equipped)

The flashing amber light is located on top of the turret of the MEWP.

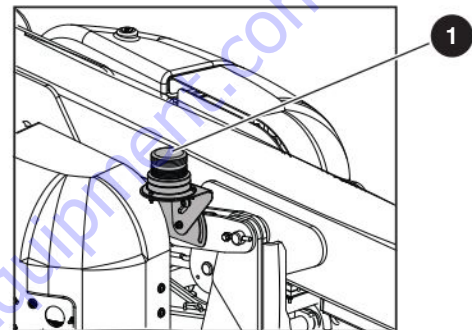

Figure 15 Flashing amber light

- 1 **Flashing amber light** - This light flashes when a boom function is activated. This works in conjunction with the all motion alarm.

3.5-3 1000W/120V AC inverter (if equipped)

The inverter is located on the base of the MEWP. It has the following controls:

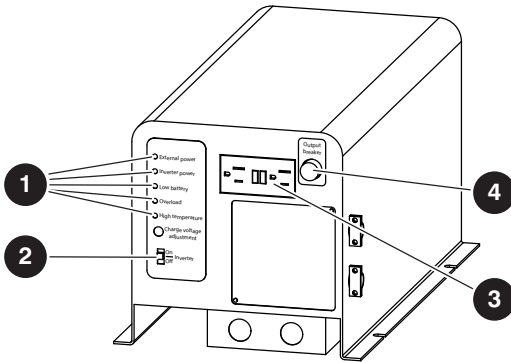

Figure 16 1000W/120V AC inverter

NOTE

The inverter operation is automatic. These controls do not need to be manipulated for normal operation.

- ① **Status LEDs** - These LEDs indicate the operating or fault status of the inverter.
- ② **On/off switch** - This diagnostic slide switch activates or terminates inverter operation. It should remain in on position.
- ③ **GFCI outlet** - During inverter operation, this outlet provides AC power.
- ④ **15 Amp circuit breaker** - In the event of a power overload or circuit grounding, the circuit breaker pops out. Press the breaker back in to reset.

3.5-4 Elevate telematics - access control unit (if equipped)

Access control is an added functionality of the Elevate Trackunit which can be used in Skyjack vertical masts, scissor lifts, booms or telehandlers.

The access control functionality **DOES NOT** affect any of the following: emergency lowering, secondary guarding electrical (if equipped), load sensing (if equipped), and horn. These functions will always remain available. The access control unit prevents the electric motor from operating for normal functions without an authorized code or card.

IMPORTANT

It is the owner's responsibility to provide unique PIN codes or smart ID cards for machines equipped with access control functionality. Skyjack DOES NOT provide or reset PIN codes or Smart ID cards. If the PIN code or smart ID card does not work or has been lost, contact the owner of the machine for assistance.

Access control functionality enables the user to control access to machine operation. The user may be provided with unique PIN codes or smart ID cards that they need to use to unlock and activate the machine. An Elevate Telematics device and an access control keypad are required to have this functionality. Access control to the MEWP may be customized by the machine owner using the Trackunit manager (<https://www.trackunit.com/services/manager/>).

If PIN code or smart ID card has not been provided or does not work, contact the machine owner.

NOTE

*It is the owner's responsibility to provide unique PIN codes or smart ID cards if machines are equipped with this functionality. Skyjack **DOES NOT** provide or reset PIN codes or smart ID cards.*

If the MEWP is equipped with the access control functionality, it will require an access PIN code or smart ID card to be operated.



Figure 17 Access control unit keypad

- 1 **Orange indicator light:** This light indicates that the access control unit is ON. The keypad is always powered regardless of emergency stop, key switch, or main power disconnect position.
 - 2 **Green indicator light:** This light indicates that the access control unit is active.
- Red indicator light** - This light flashes when a cancel input has been received from the keypad.

Operation

To permit operation of the machine, the green light on the access control unit keypad must be ON and the main power disconnect switch, the base emergency stop, and the base key switch must all be in the ON position. The access control unit is enabled by entering the unique PIN code followed by the green checkmark, or tapping the smart ID card. Unless activated prior to enabling the access control unit, the main power disconnect, base emergency stop and base key switch all must be in the ON position within the time set by the machine owner for access control operation.

Using keypad:**NOTE**

The keypad is touch sensitive. An audible beep will provide feedback that input was successfully received.

1. Enter PIN code.
2. Press green checkmark to confirm.
 - **Result:** Green light indicates authorized ID. Begin operation.

NOTE

If an incorrect button is pressed while inputting the PIN code, press the Cancel key to start over.

Using smart ID card:

1. Place card in front of reader.
2. A beep signal indicates card has been read.
 - **Result:** Green light indicates authorized ID. Begin operation.

NOTE

The controls must become active within the time set by the machine owner for access control operation. DO NOT use keypad and tap card simultaneously.

IMPORTANT

The access control unit will time out and become inactive if the operator has not completed the activation of the controls. The length of time before the unit times out is set by the machine owner. If the access control unit times out, the operator needs to enter the unique PIN code or tap the smart ID card again. If access control activation fails, contact the machine owner.

IMPORTANT

The access control unit will become inactive if the operator performs any of the following power disconnections, and the predetermined amount of time set by the machine owner has elapsed:

- turns the main power disconnect to the OFF position, pushes in the base emergency stop button or turns the key switch to the OFF position.

Skyjack DOES NOT manage the time out settings of the access control unit. Contact machine owner if time out settings need to be modified.

IMPORTANT

To reactivate the access control unit, the operator needs to enter the unique PIN code or tap the smart ID card again. To maintain access, the operator must ensure that the main power disconnect is in the ON position, the base emergency stop is pulled out, and that the key switch is in platform or base mode within the time set by the machine owner for access control functionality.

Function tests

Perform the function tests as described in [Section 4.3](#).

When performing the function tests, confirm that the access control unit is active by verifying that the green light on the keypad is ON. When performing main power disconnect, base emergency stop, and off/platform/base switch function tests, the operation must be performed within the time set by the machine owner for access control operation.

Section 4 – Pre-operation

4.1 Operator's Responsibility

It is the responsibility of the operator, prior to each work shift, to perform the following:

1. Visual and daily maintenance inspections

- designed to discover any damage of components before the MEWP is put into service.
- done before the operator performs the function tests.

WARNING

Failure to locate and repair damage, and discover loose or missing parts may result in an unsafe operating condition.

2. Function tests

- designed to discover any malfunctions before the MEWP is put into service.

IMPORTANT

The operator must understand and follow the step-by-step instructions to test all MEWP functions.

The operator should make a copy of the operator's checklist (see [Section 4.4](#)) and fill out the visual and daily maintenance inspections and the function tests sections while performing the items outlined in [Section 4.2](#) and [Section 4.3](#) respectively.

IMPORTANT

If MEWP is damaged or any unauthorized variation from factory-delivered condition is discovered, MEWP must be tagged and removed from service.

Repairs to the MEWP may only be made by qualified/competent repair personnel. After repairs are completed, the operator must perform visual and daily maintenance inspections, and function tests again.

Scheduled maintenance inspections shall only be performed by a qualified/competent person.

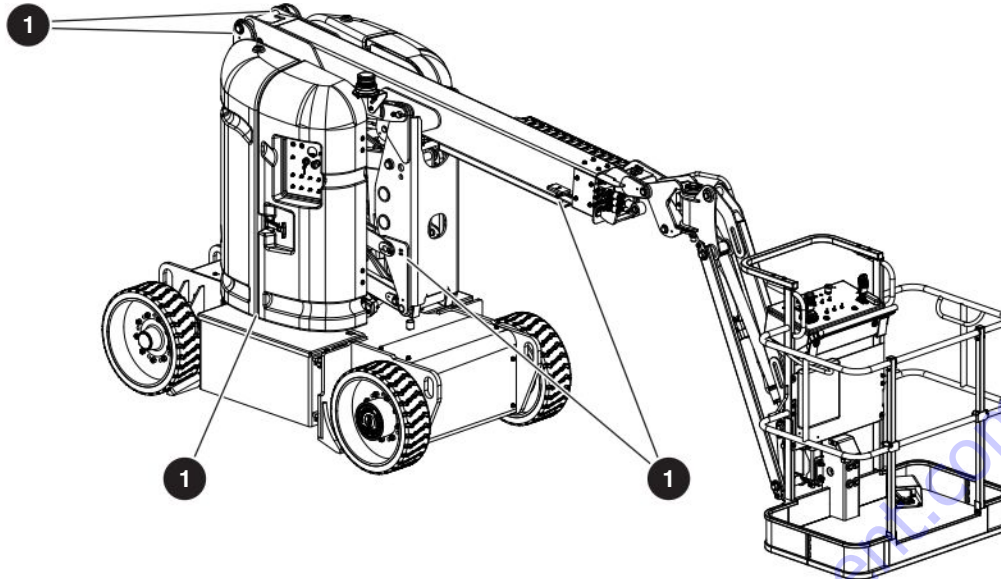
Limit switch locations

4.2 Visual & Daily Maintenance Inspections

Begin the visual and daily maintenance inspections by checking each item in sequence for the conditions listed in this section.

WARNING

To avoid injury, do not operate a MEWP until all malfunctions have been corrected.

WARNING

To avoid possible injury, ensure MEWP power is off during your visual and daily maintenance inspections.

CAUTION

Ensure MEWP is on a firm, level surface.

NOTE

While performing visual and daily inspections in different areas, be aware to also inspect limit switches, electrical and hydraulic components.

4.2-1 Labels

Refer to [Section 8](#) in this manual and determine that all labels are in place and are legible.

4.2-2 Electrical

Maintaining the electrical components is essential to good performance and service life of the MEWP.

Inspect the following areas for chafed, corroded and loose wires:

- boom to platform cable harness
- battery tray wiring harnesses
- hydraulic/electrical wiring harnesses
- steer sensor wires

4.2-3 Limit switches

Ensure limit switches ① are properly secured with no signs of visible damage and movement is not obstructed.

4.2-4 Hydraulic

Maintaining the hydraulic components is essential to good performance and service life of the MEWP.

Perform a visual inspection around the following areas:

- hydraulic tank filter, fittings, hoses, emergency power unit and turret/base surface
- hoses, main pump, filter and turret/base surface
- all hydraulic cylinders
- all hydraulic manifolds
- the underside of the turret
- the underside of the base
- ground area under the MEWP

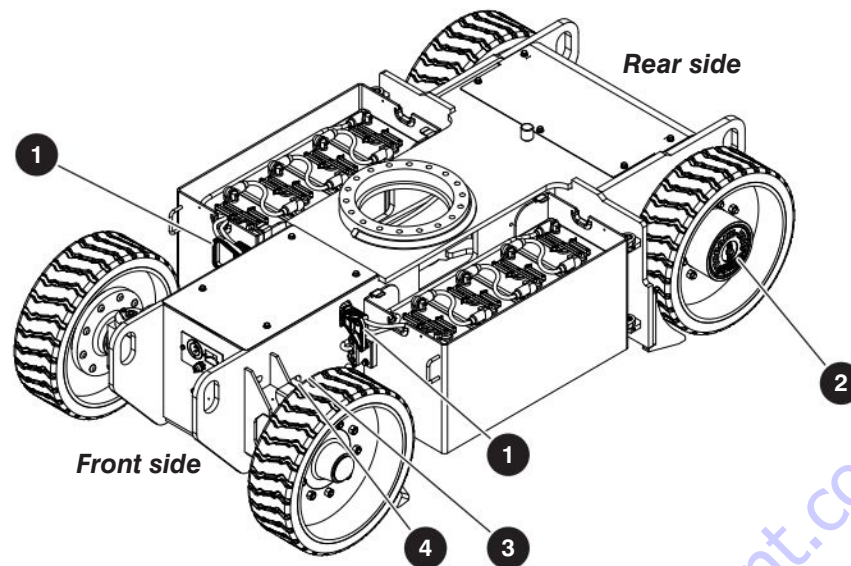

4.2-5 Base

1 Main power connectors

- Disconnect and lock out connector on either the left or right side of the MEWP.
- Ensure all cables are secure and the connector is in proper working condition and has no visible damage.

2 Torque hubs

- Ensure drive axle is properly secured, there are no loose or missing parts, all fittings and hoses are properly tightened and there is no evidence of hydraulic leakage.

3 Steer cylinder assembly

- Ensure steer cylinder assembly is properly secured, there are no loose or missing parts, all fittings and hoses are properly tightened and there is no evidence of hydraulic leakage.

4 Tie rod

- Ensure there are no loose or missing parts, tie rod end studs are locked and there is no visible damage.

5 Wheel/Tire assembly

- The MEWP is equipped with solid rubber tires. Tire and/or wheel failure could result in an MEWP tip-over. Component damage may also result if problems are not discovered and repaired in a timely fashion.

1. Check all tire treads and sidewalls for cuts, cracks, punctures and unusual wear.
2. Check each wheel for damage and cracked welds.

3. Check each bolt for proper torque to ensure none are loose.
4. Check wheel motor assembly for loose or missing parts and signs of visible damage.
5. Ensure wheels are aligned and true vertically and horizontally.

Refer to [Section 7.6](#) for wheel/tire specifications.

⚠ WARNING

Do not use tires other than those specified for this machine. Do not mix different types of tires. Tires other than those specified can adversely affect stability. Failure to operate with matched, approved tires in good condition may result in death or serious injury. Replace tires with the exact, Skyjack-approved types only.

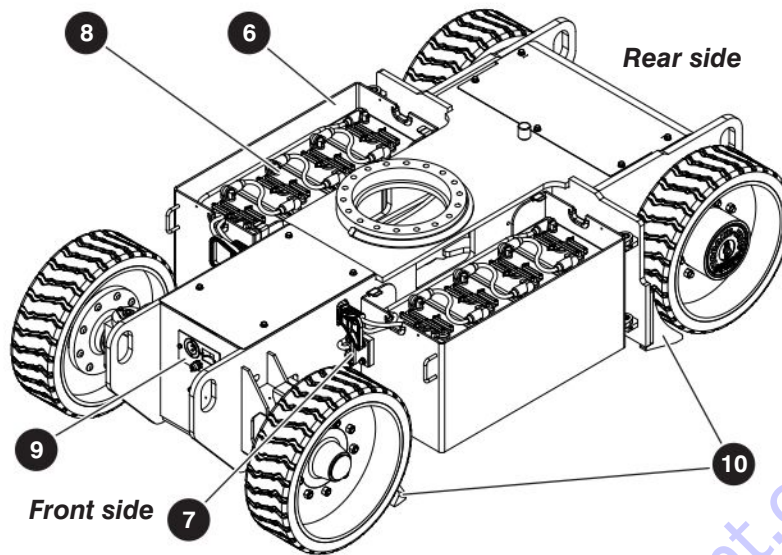

6 Battery trays

- Ensure tray latches **7** are secure and in proper working order.

8 Batteries

- Proper battery condition is essential to good performance and operational safety. Improper fluid levels or damaged cables and connections can result in component damage and hazardous conditions.

⚠ WARNING



Explosion hazard. Keep flames and sparks away. Do not smoke near batteries. Battery acid releases explosive gas while charging. Charge batteries in a well-ventilated area.

⚠ WARNING

Battery acid is extremely corrosive - Wear proper eye and facial protection as well as appropriate protective clothing. If contact occurs, immediately flush with cold water and seek medical attention.

1. Check battery case for damage.
2. Ensure all battery connections are tight.
3. If applicable, check battery fluid level. If plates are not covered by at least 13 mm (1/2") of solution, add distilled or demineralized water.

⚠ WARNING

Use original or manufacturer-approved parts and components for the MEWP.

9 Battery charger

- Ensure charger is secure and shows no visible damage.

10 Pothole protection

- Ensure there are no visible cracks and there are no signs of damage or deformation.

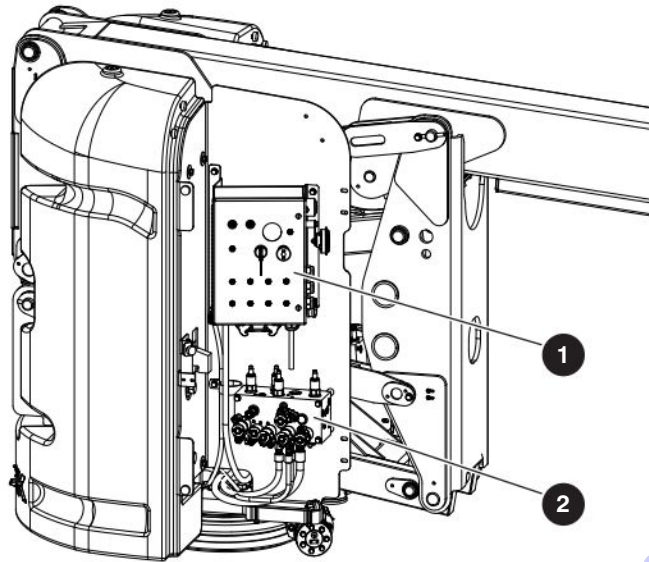

4.2-6 Control compartment

Ensure all compartment latches are secure and in proper working order.

1 Base control console

- Ensure all switches are returned to their neutral positions.
- Ensure there are no loose or missing parts and there is no visible damage.

2 Main manifold

- Ensure all fittings and hoses are properly tightened and there is no evidence of hydraulic leakage.
- Ensure there are no loose wires or missing fasteners.

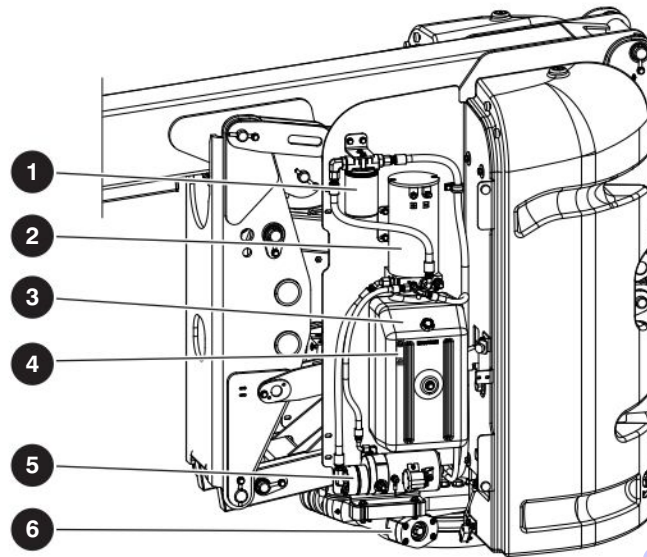

4.2-7 Motor/Hydraulic compartment

Ensure all compartment latches are secure and in proper working order.

1 Hydraulic filter

- Ensure housing is secure and shows no visible damage or leakage.

2 Hydraulic pump/motor

- Ensure there are no loose or missing parts and there is no visible damage.
- Ensure all bolts are properly tightened.
- Ensure all fittings and hoses are properly tightened and there is no evidence of hydraulic leakage.

3 Hydraulic tank

- Ensure hydraulic filler cap is secure.
- Ensure tank shows no visible damage and no evidence of hydraulic leakage.

4 Hydraulic oil

- Ensure boom is in stowed position, and then visually inspect the sight gauge located on the side of the hydraulic oil tank.
- The hydraulic oil level should be between the minimum and maximum marks on the sight glass. Add oil as needed. Refer to service manual for recommended oil type.

5 Emergency power unit

- Ensure there are no loose or missing parts and there is no visible damage.
- Ensure there are no loose wires or missing fasteners.
- Ensure all fittings and hoses are properly tightened and there is no evidence of hydraulic leakage.

6 Turret rotation motor/gear

- Ensure there are no loose or missing parts and there is no visible damage.
- Ensure all bolts are properly tightened.
- Ensure all fittings and hoses are properly tightened and there is no evidence of hydraulic leakage.

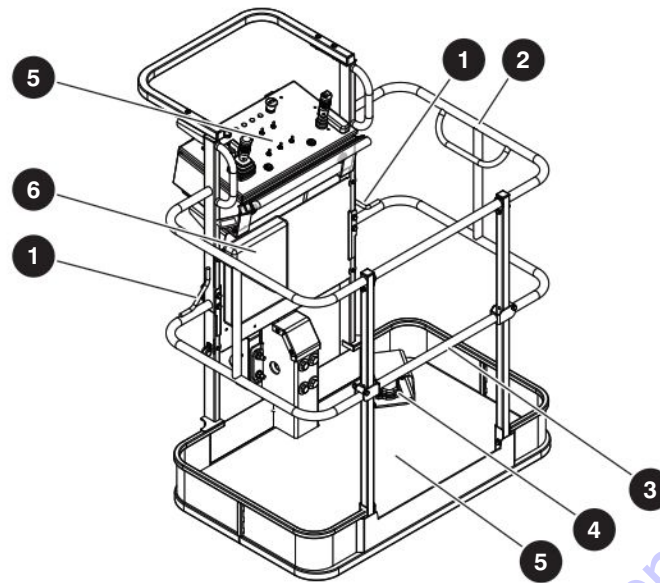

4.2-8 Platform assembly

- Ensure there are no loose or missing parts and there is no visible damage.
- Ensure all fasteners are securely in place.
- Ensure fall protection anchorage(s) ❶ are secure and there is no visible damage.
- Ensure all railings ❷ are properly positioned and secured.
- Ensure gate (if equipped)/drop bar ❸ is in good working order.
- Ensure footswitch ❹ is in good working order and has not been modified, disabled or blocked.
- Ensure MEWP floor ❺ is secure and there is no visible damage.
- Ensure AC outlet has no visible damage and is free from dirt or obstructions.

❺ Platform control console

- Ensure all switches/controllers are returned to neutral.
- Ensure there are no loose or missing parts and there is no visible damage.

❻ Manuals

- Ensure a copy of operating manual, and other important documents are enclosed in manual storage box.
1. Check to be sure manual storage box is present and in good condition.
 2. Ensure manuals are legible and in good condition.
 3. Always return manuals to the manual storage box after use.

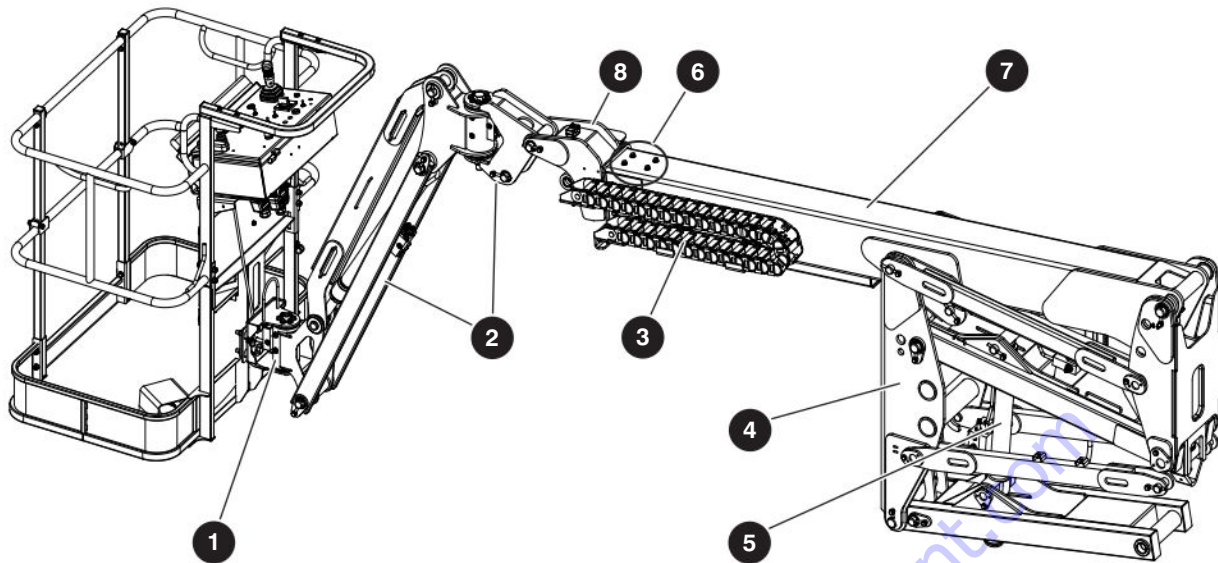

4.2-9 Boom assembly

1 Rotary actuator

- Ensure there are no loose or missing parts and there is no visible damage.
- Ensure all bolts and pins are properly tightened.
- Ensure all hoses are properly tightened and there is no evidence of hydraulic leakage.

2 Jib (non-rotating and rotating)

- Ensure there are no loose or missing parts and there is no visible damage.
- Ensure all bolts and pins are properly tightened.
- Ensure all hoses are properly tightened and there is no evidence of hydraulic leakage.

3 E-chain

- Ensure there are no loose or missing parts and there is no visible damage.

4 Riser

- Ensure there are no loose or missing parts and there is no visible damage.
- Ensure all bolts and pins are properly tightened.
- Ensure there are no visible cracks in welds or structure and there are no signs of deformation.
- Ensure all hoses are properly tightened and there is no evidence of hydraulic leakage.

5 Cylinders

- Ensure all cylinders are properly secured and there is no evidence of leakage.

6 Wear pads

- Ensure all bolts are tight, there is no visible damage to the wear pads and that no parts are missing.

Main 7 and Fly 8 booms

- Ensure there are no loose or missing parts and there is no visible damage.
- Ensure all bolts and pins are properly tightened.
- Ensure there are no visible cracks in welds or structure and there are no signs of deformation.
- Ensure all hoses are properly tightened and there is no evidence of hydraulic leakage.

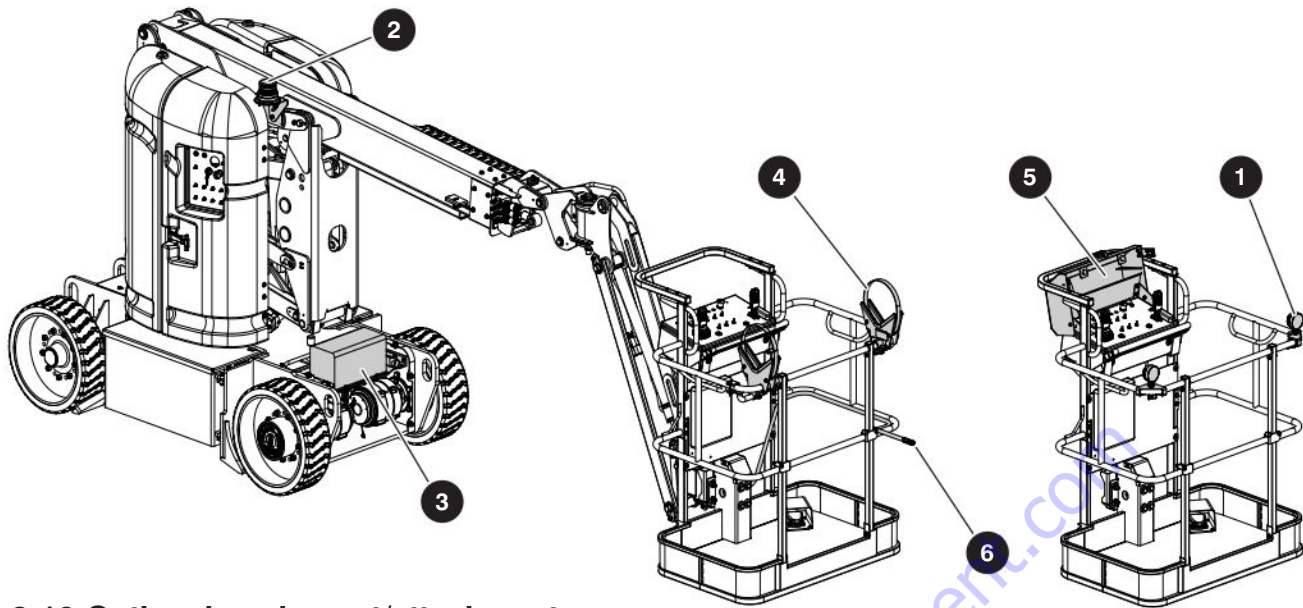

4.2-10 Optional equipment/attachments

1 Work light (if equipped)

- Ensure lamps are properly secured with no signs of visible damage.
- Ensure mounting bracket is properly secured.
- Ensure there are no loose wires or missing fasteners.

2 Flashing amber light (if equipped)

- Ensure lamp is properly secured with no signs of visible damage.

3 Inverter (if equipped)

- Ensure inverter is properly secured with no signs of visible damage.

4 Pipe rack (if equipped)

- Ensure pipe rack assemblies are properly secured with no signs of visible damage.

5 Control box cover (if equipped)

- Ensure control box cover is properly secured with no signs of visible damage.

6 Air line (if equipped)

- Ensure air line is properly secured with no signs of visible damage.

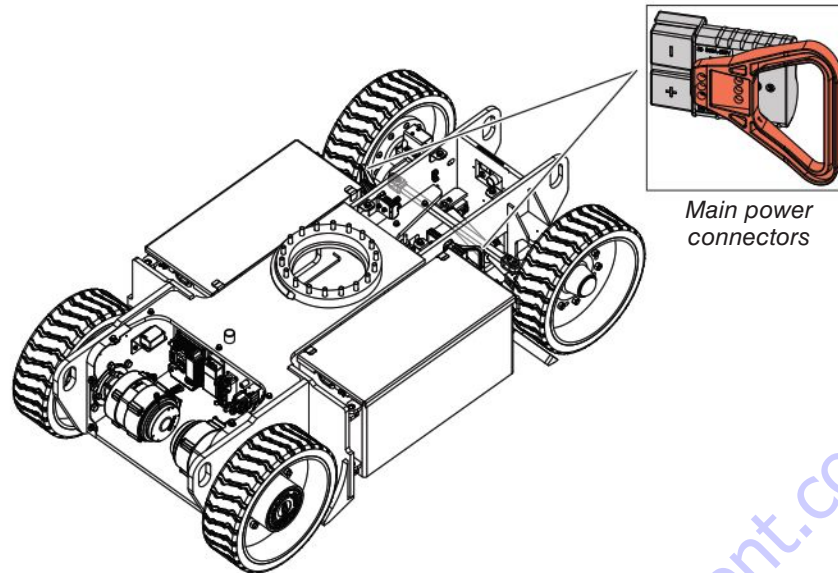

4.3 Function Tests

Function tests are designed to discover any malfunctions before MEWP is put into service. The operator must understand and follow step-by-step instructions to test all MEWP functions.

WARNING

Never use a malfunctioning MEWP. If malfunctions are discovered, MEWP must be tagged and taken out of service. Repairs to MEWP may only be made by qualified/competent repair personnel.

After repairs are completed, operator must perform a pre-operation inspection and a series of function tests again before putting MEWP into service.

Prior to performing function tests, be sure to read and understand [Section 5.1: Start Operation](#).

NOTE

All motion alarm should sound while activating the footswitch.

4.3-1 Testing main power connectors

1. On the left side of the MEWP, disconnect and lock out connector.
 - **Result:** MEWP functions should not operate.
2. Remove lock and plug in connector.
 - **Result:** Power to MEWP should be restored.
3. On the right side of the MEWP, disconnect and lock out connector.
 - **Result:** MEWP functions should not operate.
4. Remove lock and plug in connector.
 - **Result:** Power to MEWP should be restored.

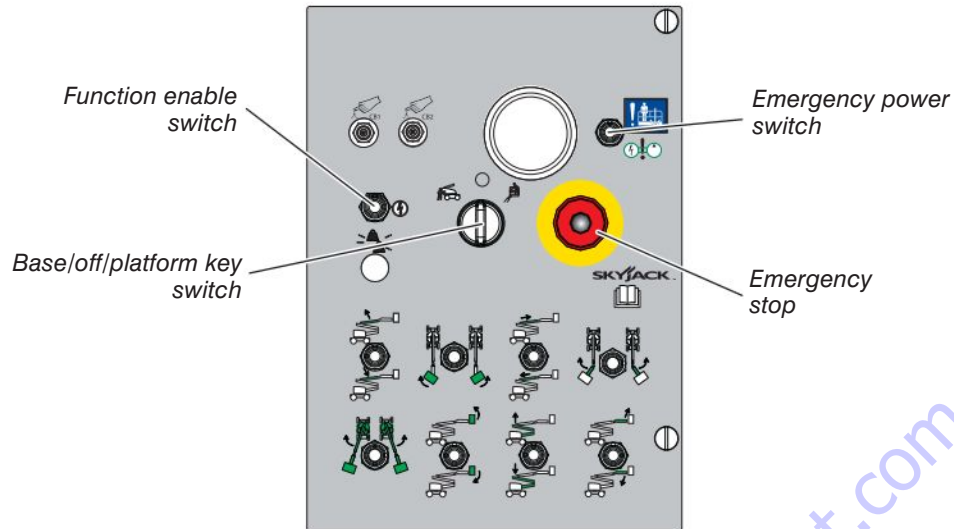

4.3-2 Base control console

NOTE

While operating the emergency power unit, the base controls will override the platform controls, even when the emergency stop button on the platform is depressed.

1. On platform control console, pull out emergency stop button.

WARNING

Ensure that you maintain three points of contact to mount/dismount platform.

4.3-3 Testing base emergency stop light and base emergency stop button

1. Turn base/off/platform key switch to base position.
2. On base control console, pull out emergency stop button.
 - **Result:** Emergency stop light should continuously illuminate.
3. Push in emergency stop button and attempt to raise or lower the platform.
 - **Result:** Platform raising and lowering functions should not operate.
4. Pull out emergency stop button.

4.3-4 Testing function enable switch and all boom functions

WARNING

Ensure that there are no personnel or obstructions in test area and there is sufficient room for boom to swing.

1. Do not hold function enable switch. Attempt to activate each boom and platform switch.
 - **Result:** All boom and platform functions should not operate.
2. Hold function enable switch and activate each boom and platform function.
 - **Result:** All boom and platform functions should operate as selected.

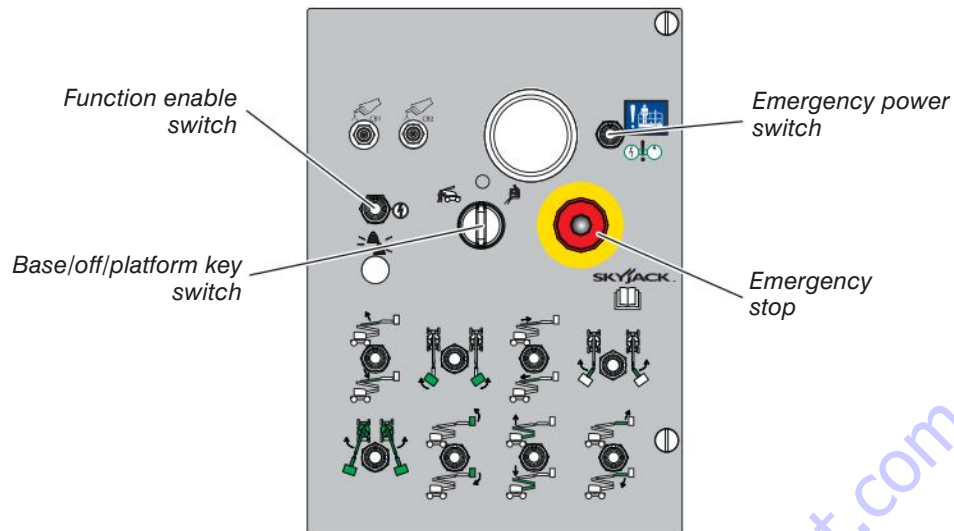

4.3-5 Testing platform self-leveling

1. Lower boom to stowed position.
2. Adjust platform to a level position using platform leveling switch, which controls tilting up or tilting down of platform.
3. Raise and lower main boom through a full cycle.
 - **Result:** Platform should remain level at all time.

4.3-6 Testing emergency power

1. On platform control console, push in emergency stop button.

CAUTION

When operating on emergency power, do not operate more than one function at a time to avoid overloading 24-Volt emergency pump motor. Do not use emergency power unit continuously for more than two minutes.

NOTE

To conserve battery power, test each function through a partial cycle.

2. On base control console, ensure emergency stop button is pulled out.
3. Turn base/off/platform key switch to base position.
4. Turn emergency power switch to on position and activate each boom function.
 - **Result:** All selected functions should operate.

NOTE

The emergency power unit has two-minute duty cycle.

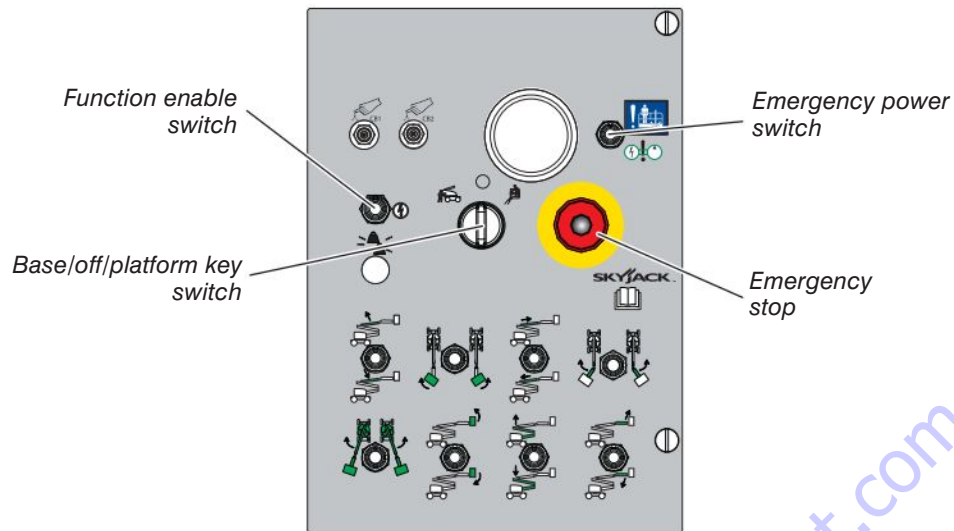

4.3-7 Testing base/off/platform switch

1. Ensure both emergency stop buttons are pulled out.
2. On base control console, turn base/off/platform key switch to off position. Attempt to raise or lower the platform.
 - **Result:** Platform raising and lowering functions should not operate.
3. On base control console, turn off/base platform key switch to platform position.
4. On base control console, attempt to activate each boom and platform switch while holding function enable switch.
 - **Result:** All boom and platform functions should not operate while holding function enable switch.
5. On base control console, turn off/platform/base key switch to base position. Attempt to raise or lower the platform.
 - **Result:** Platform raising and lowering functions should operate.

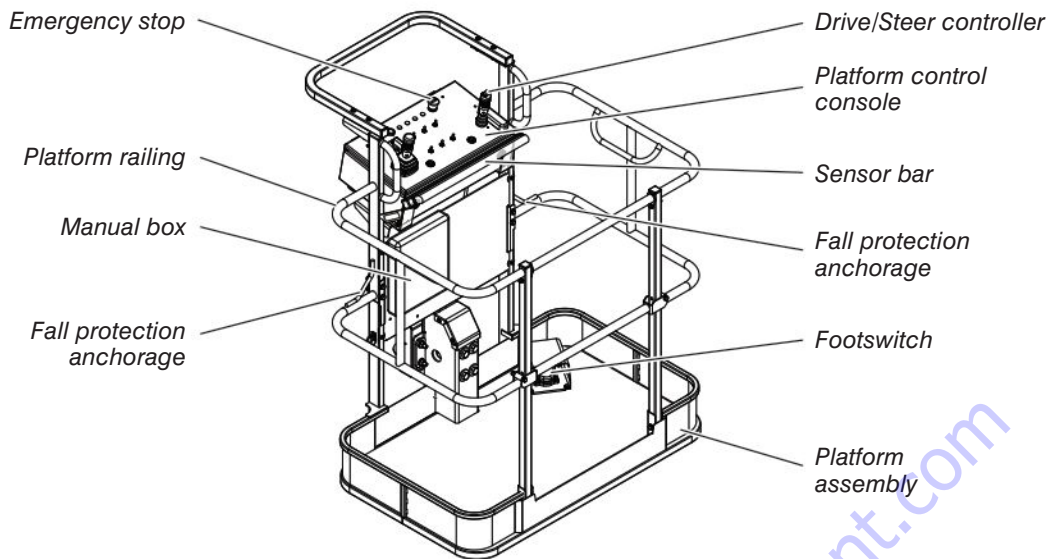

4.3-8 Platform control console

⚠ WARNING

Ensure that you maintain three points of contact to mount/dismount platform.

1. Ensure both emergency stop buttons are pulled out.
2. Turn the base/off/platform key switch to the platform position.
3. Enter platform and close gate (if equipped).

⚠ WARNING

DO NOT operate any control on platform control console without proper fall protection secured to designated location in platform. Failure to avoid this hazard could result in death or serious injury!

⚠ WARNING

Ensure that there are no personnel or obstructions in test area and that there is sufficient room for boom to swing.

4.3-9 Testing secondary guarding electrical (SGE)

1. Press the sensor bar for less than 1 second and then release.
 - **Result:** The audible/visual alarm should activate while the bar is being pressed and turn off after being released. The reset button should illuminate as soon as the sensor bar is pressed, and turn off when the bar is released.
2. Press the sensor bar for more than 1 second and then release.
 - **Result:** The audible/visual alarm should activate immediately and stay on after the bar is released. The reset button should illuminate.
3. Press the reset button.
 - **Result:** The audible/visual alarm and reset button light should go off.
4. Press the sensor bar for more than 1 second and then release.
 - **Result:** The audible/visual alarm should activate immediately and stay on after the bar is released. The reset button should illuminate.
5. Depress and hold footswitch.
6. Turn emergency power switch to on position and activate any function (except drive/steer) momentarily.
 - **Result:** The function should operate and the platform audible/visual alarm and reset button light should turn off.

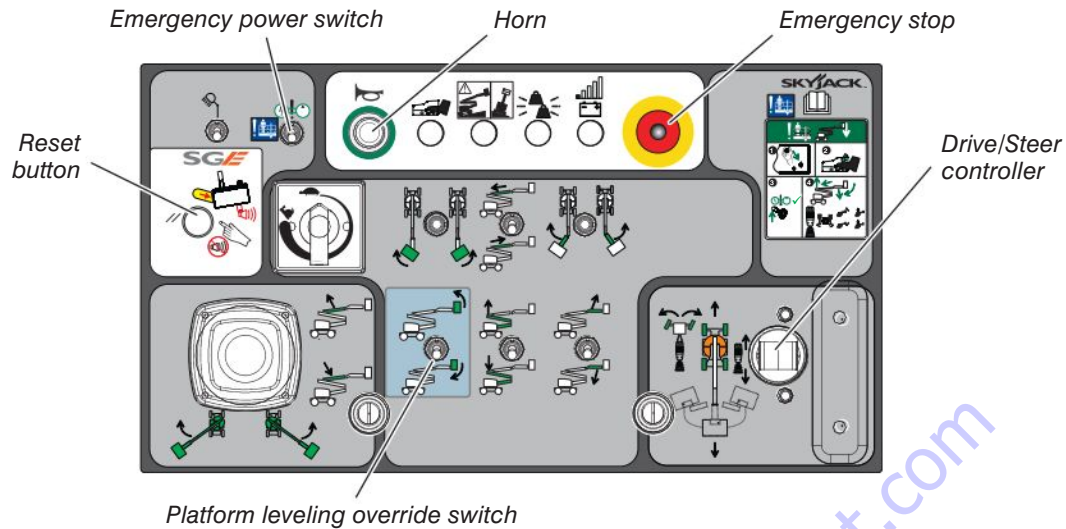

7. Activate any drive function.
 8. Press the sensor bar for less than 1 second and then release.
 - **Result:** The function will stop while the bar is being pressed and motion will resume when the bar is released. The audible/visual alarm should activate while the bar is being pressed and turn off after being released. The reset button should illuminate as soon as the sensor bar is pressed and turn off when the bar is released.
 9. Press the sensor bar for more than 1 second and then release.
 - **Result:** The function will stop and the audible/visual alarm should activate immediately and stay on after the bar is released. The reset button should illuminate.
 10. Press the reset button.
 - **Result:** The audible/visual alarm and reset button light should go off.
 11. Activate any platform function (i.e. lift/extend/rotate).
 12. Press the sensor bar for less than 1 second and then release.
 - **Result:** The function will stop while the bar is being pressed and motion will resume when the bar is released. The audible/visual alarm should activate while the bar is being pressed and turn off after being released. The reset button should illuminate as soon as the sensor bar is pressed and turn off when the bar is released.
 13. Press the sensor bar for greater than 1 second and then release.
 - **Result:** The function will stop and the audible/visual alarm should activate immediately and stay on after the bar is released. The reset button should illuminate.
 14. While the audible/visual alarm is sounding, verify that the LED solid light is also active.
- ⚠ WARNING**
- Ensure that you maintain three points of contact to mount/dismount platform.**
-
15. Exit the platform.
 16. Turn base/off/platform key switch to base position.
 17. On the base control console, activate the emergency power switch and the function enable switch and any function momentarily.
 - **Result:** The function should operate and the platform audible/visual alarm and reset button light should turn off.
- ⚠ WARNING**
- Ensure that you maintain three points of contact to mount/dismount platform.**
-
18. Enter platform and close gate (if equipped).

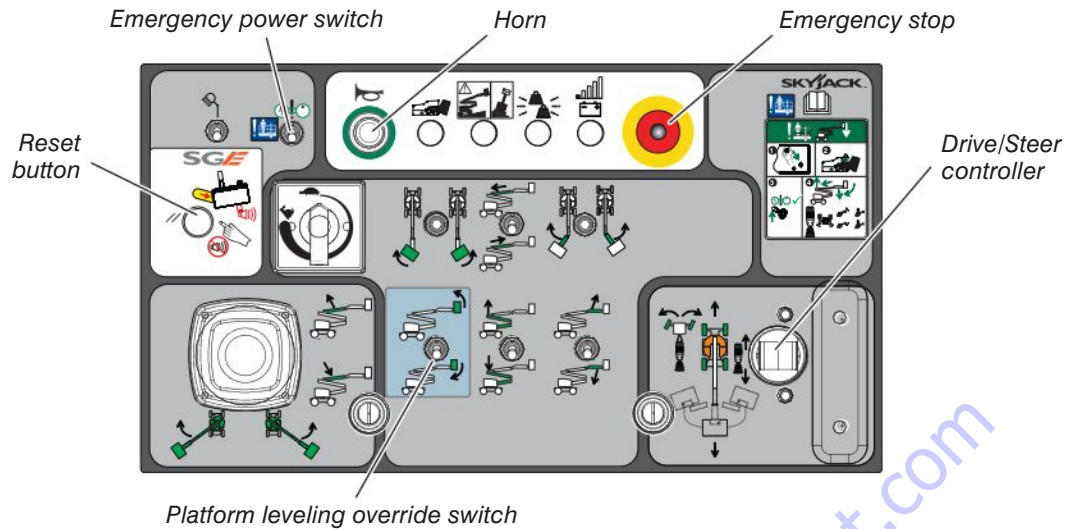

4.3-10 Testing platform emergency stop light and platform emergency stop button

1. On platform control console, pull out emergency stop button.
 - **Result:** Emergency stop light should continuously illuminate.
2. Push in emergency stop button and attempt to activate any MEWP function.
 - **Result:** All selected MEWP functions should not operate.

4.3-11 Testing footswitch

1. On platform control console, pull out emergency stop button.
2. Without depressing footswitch, test each boom and platform function.
 - **Result:** MEWP functions should not operate.

NOTE

A 7-second anti-tiedown feature deactivates footswitch when operator depresses it for 7 seconds without activating any function.

4.3-12 Testing steering

1. Depress and hold footswitch.
2. Press rocker switch on top of drive/steer controller to left and right.
 - **Result:** Steer wheels should turn left and right.

4.3-13 Testing driving function

WARNING

Ensure that there are no personnel or obstructions in the path of travel, including blind spots.

1. Ensure path of intended motion is clear.
2. Ensure boom is in stowed position and fly boom is fully retracted.

NOTE

Stowed position indicates that the MEWP is in the fully retracted state, the boom and basket are centered between the drive wheels and the steer wheels are facing straight ahead.

3. Depress and hold footswitch.
4. Slowly move drive/steer controller in forward or backward direction until MEWP begins to move, and then return handle to center position.
 - **Result:** MEWP should move forward in the direction of the steer wheels when the drive/steer controller is pushed forward and backward in the direction of the drive wheels when the drive/steer controller is pulled backward.

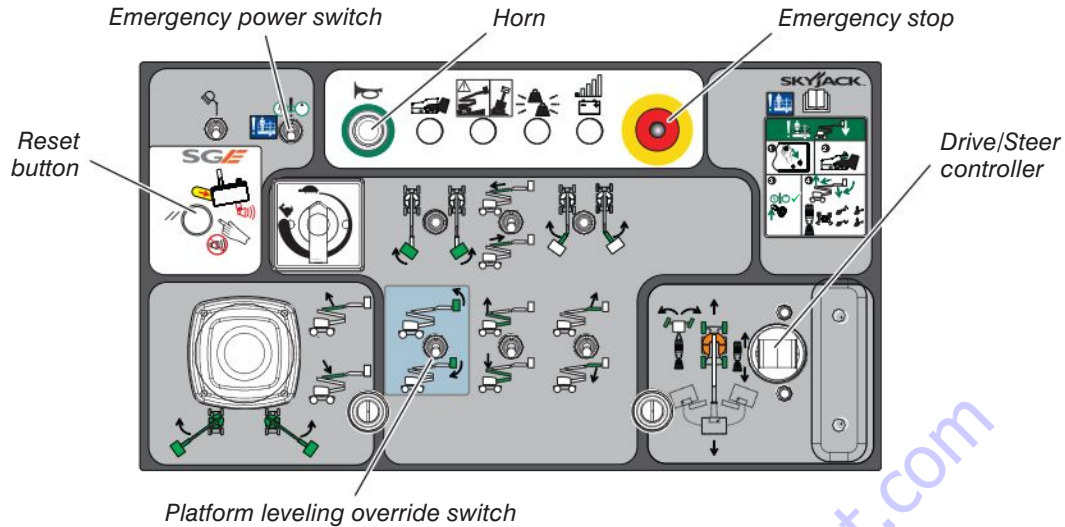

5. Rotate turret past 90 degrees from the stowed position.
6. Repeat steps 3 and 4.
 - **Result:** MEWP should move forward in the direction of the drive wheels when the drive/steer controller is pushed forward and backward in the direction of the steer wheels when the drive/steer controller is pulled backward.

NOTE

The general direction of the turret and boom relative to the chassis indicates the forward direction of motion.

4.3-14 Testing driving speed

1. Depress and hold footswitch.
2. Raise main boom to 15 degrees above horizontal and then slowly move drive/steer controller to full drive position.
 - **Result:** The maximum achievable drive speed should be significantly less than stowed drive speed.
3. Lower main boom to stowed position.
4. Extend fly boom approximately 10 cm (4 in) and then slowly move drive/steer controller to full drive position.
 - **Result:** The maximum achievable drive speed should be significantly less than stowed drive speed.

5. Retract fly boom.
6. Raise riser until upper riser arm is horizontal and then slowly move drive/steer controller to full drive position.
 - **Result:** The maximum achievable drive speed should be significantly less than stowed drive speed.
7. Lower riser to stowed position.

4.3-15 Verifying load sensing module self-check

1. Push in emergency stop button.
2. Pull out emergency stop button.
 - **Result:** After four seconds of time elapses, the red light and audible alarm pulse two times. This indicates the system is active and there are no faults.

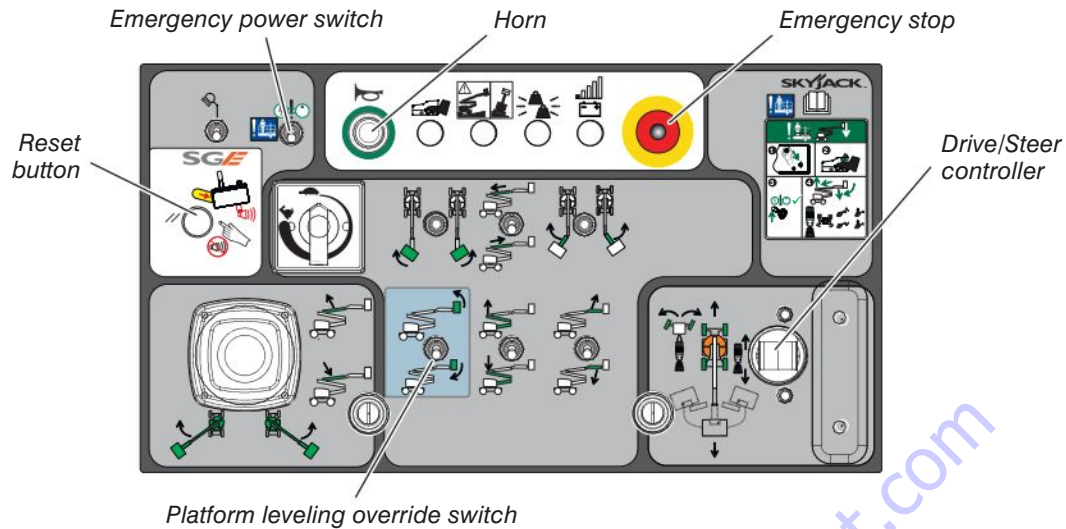

4.3-16 Testing emergency power

CAUTION

When operating on emergency power, do not operate more than one function at a time to avoid overloading 24-Volt emergency pump motor. Do not use emergency power unit continuously for more than two minutes.

NOTE

To conserve battery power, test each function through a partial cycle.

1. Depress and hold footswitch.
2. Turn emergency power switch to on position and activate each function control handle or switch.
 - **Result:** All boom functions should operate, except drive/steer functions.

NOTE

The emergency power unit has two-minute duty cycle.

4.3-17 Testing horn

1. Push horn pushbutton.
 - **Result:** Horn should sound.

4.3-18 Testing brakes

WARNING

Brakes will engage instantly when you release footswitch, causing MEWP to stop immediately.

1. Move MEWP to a firm, level surface to ensure similar traction on left and right hand side tires.
2. Ensure boom is in stowed position and the steer wheels are facing straight ahead.
3. Depress and hold footswitch and drive MEWP forward.
 - **Result:** MEWP should come to an abrupt stop. If MEWP does not stop immediately, or if MEWP pulls to one side while stopping, do not operate MEWP until brake adjustments have been checked.
4. Remove your foot from footswitch.
 - **Result:** MEWP should come to an abrupt stop. If MEWP does not stop immediately, or if MEWP pulls to one side while stopping, do not operate MEWP until brake adjustments have been checked.
5. Repeat steps 3 and 4 for driving in reverse.

4.3-19 Testing manual platform leveling

1. Depress and hold footswitch.
2. On platform leveling override switch, select up position to tilt platform up or down position to tilt platform down.
 - **Result:** Platform should tilt up or down.

4.4 Operator's Checklist



Operator's Checklist

Serial Number: _____
 Model: _____
 Hourmeter Reading: _____
 Date: _____
 Time: _____

Operator's Name (Printed): _____

Operator's Signature: _____

P PASS **R** REPAIRED
F FAIL **N/A** NOT APPLICABLE

Each item shall be inspected using the appropriate section of the Skyjack operating manual. As each item is inspected, check the appropriate box.

	N/A	P	F	R
Visual and Daily Maintenance Inspections				
Labels				
Electrical				
Limit switches				
Hydraulic				
Base				
Main power connectors				
Torque hubs				
Steer cylinder assembly				
Tie rod				
Wheel/Tire assembly				
Battery trays				
Batteries				
Battery charger				
Pothole protection				
Control compartment				
Base control console				
Main manifold				
Motor/Hydraulic compartment				
Hydraulic filter				
Hydraulic pump/motor				
Hydraulic tank				
Hydraulic oil				
Emergency power unit				
Turret rotation motor/gear				
Platform assembly				
Platform control console				
Manuals				
Boom assembly				
Rotary actuator				
Jib (non-rotating/rotating)				
E-chain				
Riser				
Cylinders				
Wear pads				

	N/A	P	F	R
Main and Fly booms				
Optional equipment/attachments				
Work light (if equipped)				
Flashing amber light (if equipped)				
Inverter (if equipped)				
Pipe rack (if equipped)				
Control box cover (if equipped)				
Air line (if equipped)				
Function Tests				
Testing main power connectors				
Base control console				
Testing base emergency stop light and base emergency stop button				
Testing function enable switch and all boom functions				
Testing platform self-leveling				
Testing emergency power				
Testing base/off/platform switch				
Platform control console				
Testing secondary guarding electrical (SGE)				
Testing platform emergency stop light and platform emergency stop button				
Testing footswitch				
Testing steering				
Testing driving function				
Testing driving speed				
Verifying load sensing module self-check				
Testing emergency power				
Testing horn				
Testing brakes				
Testing manual platform leveling				

1417AA

NOTE: Make a copy of this page or visit the Skyjack website at www.skyjack.com for a printable copy.

Section 5 – Operation

This section provides the necessary information needed to operate the MEWP. Read and completely understand the operating manual and all warnings and instruction labels (refer to [Section 8](#)) on the MEWP.

WARNING

Do not operate this MEWP without proper authorization and training. Doing so could result in death or serious injury.

Before operating this MEWP, perform the following tasks:

1. Visual and daily maintenance inspections (refer to [Section 4.2](#))
2. Function tests (refer to [Section 4.3](#))
3. Jobsite inspection (refer to [Section 2.4](#)).
4. If, as a result of the risk assessment, the need for rescue planning is identified, a system of communication shall be established between people working on the platform and nominated support personnel trained in the use of ground controls for platform retrieval.

WARNING

An operator should not use any MEWP that:

- does not appear to be working properly.
- has been damaged or appears to have worn or missing parts.
- has alterations or modifications not approved by the manufacturer.
- has safety devices which have been altered or disabled.

Failure to avoid these hazards could result in death or serious injury.

5.1 Start Operation

5.1-1 Activating base control console

NOTE

While operating the emergency power unit, the base controls will override the platform controls, even when the emergency stop button on the platform is depressed.

1. On both the left and right sides of the MEWP, plug in main power connectors.

WARNING

Ensure that you maintain three points of contact to mount/dismount the platform.

2. Enter platform and close gate.
3. On platform control console, pull out emergency stop button.
4. Exit platform.
5. On base control console, turn base/off/platform key switch to base position.
6. Pull out emergency stop button.

5.1-2 Rotating platform using base control console

1. Activate and hold function enable switch by pushing it to the right or left.
2. Push platform rotation switch to either left or right position. Release switch to stop.

5.1-3 Rotating turret using base control console

WARNING

When rotating the turret, ensure that there are no personnel or obstructions in the path of rotation, including blind spots.

1. Activate and hold function enable switch by pushing it to the right or left.
2. Push turret rotation switch to either clockwise or counterclockwise position. Release switch to stop.

5.1-4 Moving jib up and down using base control console

1. Activate and hold function enable switch by pushing it to the right or left.
2. Push jib up/down switch to either up or down position. Release switch to stop.

5.1-5 Rotating jib using base control console

1. Activate and hold function enable switch by pushing it to the right or left.
2. Push jib rotation switch to either left or right position. Release switch to stop.

5.1-6 Moving riser up and down using base control console

1. Activate and hold function enable switch by pushing it to the right or left.
2. Push riser up/down switch to either up or down position. Release switch to stop.

5.1-7 Raising or lowering main boom using base control console

1. Activate and hold function enable switch by pushing it to the right or left.
2. Push boom raise/lower switch to either raise or lower position. Release switch to stop.

5.1-8 Extending or retracting fly boom using base control console

1. Activate and hold function enable switch by pushing it to the right or left.
2. Push boom extend/retract switch to either extend or retract position. Release switch to stop.

5.1-9 Leveling platform manually using base control console

1. Activate and hold function enable switch by pushing it to the right or left.
2. Push platform leveling override switch to either up or down position. Release switch to stop.

5.1-10 Operating using emergency power switch at base control console

This is a momentary-type switch. This switch allows all functions except the drive functions to operate in the event of an emergency or an electrical system failure. Refer to [Section 6.1](#) for the emergency lowering procedure.

NOTE

The emergency power unit has two-minute duty cycle.

CAUTION

Do not use emergency power unit continuously for more than two minutes.

5.1-11 Activating platform control console

1. On both the left and right sides of the MEWP, plug in main power connectors.
2. On base control console, turn base/off/platform key switch to platform position.
3. On base control console, pull out emergency stop button.

WARNING

Ensure that you maintain three points of contact to mount/dismount the platform.

WARNING

DO NOT operate any control on operator's control console without proper fall protection secured to the designated location in the platform. Failure to avoid this hazard could result in death or serious injury.

4. Enter platform.
5. Attach body harness lanyards of each occupant to fall protection anchorage points. Rated for one (1) person per anchorage.
6. On platform control console, pull out emergency stop button.

WARNING

DO NOT drive or steer the MEWP when the platform position does not allow you a clear view of the base. Your area of operation should be cordoned from other personnel or equipment.

5.1-12 Driving forward or reverse using platform control console

NOTE

The general direction of the turret and boom relative to the chassis indicates the forward direction of motion.

1. Depress and hold footswitch.
2. On platform control console, move and hold drive/steer controller to drive forward or backward.
3. Release controller handle to stop.

CAUTION

The drive orientation can change when the turret is swung 90 degrees off center of the normal driving position (roughly when boom is swung past the rear tire). Drive re-orientation will not occur while driving and rotating until the joystick is released for 6 seconds or when the footswitch is released.

CAUTION

The forward direction of travel will be in the general direction the counterweight is facing while reverse will be the opposite. Care should be taken to confirm the counterweight orientation prior to activating any drive/steer functions.

CAUTION

When driving on a slope:

- DO NOT exceed the rated gradeability listed in [Section 7.4](#).

5.1-13 Steering using platform control console

1. Depress and hold footswitch.
2. On platform control console, press rocker on top of drive/steer controller to steer left or right.

NOTE

Driving and steering may be active at the same time.

5.1-14 Moving jib up and down using platform control console

1. Depress and hold footswitch.
2. On jib up/down switch, select to move jib up or down. Release switch to stop.

5.1-15 Rotating jib using platform control console

1. Depress and hold footswitch.
2. On jib rotation switch, select to rotate jib left or right. Release switch to stop.

5.1-16 Moving riser up and down using platform control console

1. Depress and hold footswitch.
2. On riser up/down switch, select to move riser up or down. Release switch to stop.

5.1-17 Extending or retracting fly boom using platform control console

1. Depress and hold footswitch.
2. On boom extend/retract switch, select to extend or retract fly boom. Release switch to stop.

5.1-18 Rotating platform using platform control console

1. Depress and hold footswitch.
2. On platform rotation switch, select to rotate platform left or right.

5.1-19 Leveling platform using platform control console

1. Depress and hold footswitch.
2. On platform leveling override switch, select up position to tilt platform up or down position to tilt platform down.

5.1-20 Raising or lowering main boom using platform control console

1. Depress and hold footswitch.
2. Push and hold boom/turret controller to raise or lower main boom.
3. Release controller handle to stop.

5.1-21 Sounding horn

1. Press horn pushbutton to sound horn. Release pushbutton to stop sounding horn.

5.1-22 Rotating turret using platform control console

WARNING

When rotating the turret, ensure that there are no personnel or obstructions in the path of rotation, including blind spots.

1. Depress and hold footswitch.
2. Push and hold boom/turret controller in this direction to rotate clockwise or counterclockwise.
3. Release controller handle to stop.

5.1-23 Operating with emergency power switch at platform control console

This is a momentary-type switch. This switch allows all functions except drive functions to operate in the event of an emergency or an electrical system failure. Refer to [Section 6.1](#) for the emergency lowering procedure.

NOTE

The emergency power unit has two-minute duty cycle.

CAUTION

Do not use emergency power unit continuously for more than two minutes.

5.1-24 Shutdown procedure

1. Select a reasonably well-protected parking location with a firm, level surface, clear of obstructions and traffic.
2. Completely retract boom and lower platform.
3. Push in emergency stop button on platform control console and on base control console.
4. Turn base/off/platform key switch to off position. Remove key.
5. On either the left or right side of the MEWP, disconnect and lock out main power connector.
6. If necessary, cover platform control console to protect warning labels and operating controls from hostile environments.

5.1-25 Inverter (if equipped)

1. On both the left and right sides of the MEWP, plug in main power connectors.
2. Make sure on/off switch of the inverter is on position.
3. Inverter state is indicated by the LEDs on the face of the inverter. A glowing green LED indicates normal operation. If a fault occurs, the status LEDs will indicate the area responsible.

Section 6 – Additional Procedures

6.1 Emergency Lowering Procedure

This section guides the operator on how to use emergency lowering system. This system allows platform lowering in the event of an emergency or an electrical system failure.

WARNING

If the platform is overloaded due to contact with an overhead obstruction, do one of the following:

- **Remove the obstruction from the platform, then after a four-second delay normal functions can be resumed.**
- **Use the emergency power unit to release the platform from the obstruction (refer to [Section 3.4-7](#)).**
- **Do not attempt to free a snagged platform with lower controls until personnel are removed from the platform.**

NOTE

The emergency power unit has two-minute duty cycle.

CAUTION

Do not use emergency power unit continuously for more than two minutes.

At base control console:

1. Pull out emergency stop button.
2. Select base position from key switch.
3. Move and hold emergency power switch up or down and activate desired boom function.

At platform control console:

1. Pull out emergency stop button.
2. Depress and hold footswitch.
3. Move and hold emergency power switch up and activate desired boom function.

6.2 Chassis Tilt Recovery

This section guides the operator with regard to recovering from an inclined position.

IMPORTANT

When the boom is raised or extended, the MEWP must only be operated on firm, level surfaces.

WARNING

When tilt settings are exceeded, causing the alarm to sound and the light to illuminate, the platform should be lowered and retracted immediately. (refer to [Section 3.4-5](#)).

6.2-1 Platform uphill

If the MEWP becomes tilted with the platform uphill (refer to [Figure 18](#)) follow the steps below to return to a lowered and retracted position.

1. Lower main boom completely.
2. Lower riser completely.
3. Retract fly boom completely.
4. Drive to a firm, level surface.

6.2-2 Platform downhill

If the MEWP becomes tilted with the platform downhill (refer to [Figure 19](#)) follow the steps below to return to a lowered and retracted position.

1. Retract fly boom completely.
2. Lower riser completely.
3. Lower main boom completely.
4. Drive to a firm, level surface.

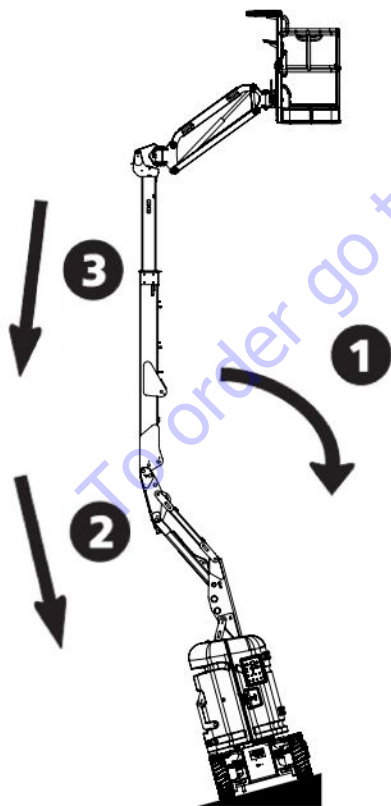

Figure 18 Platform uphill

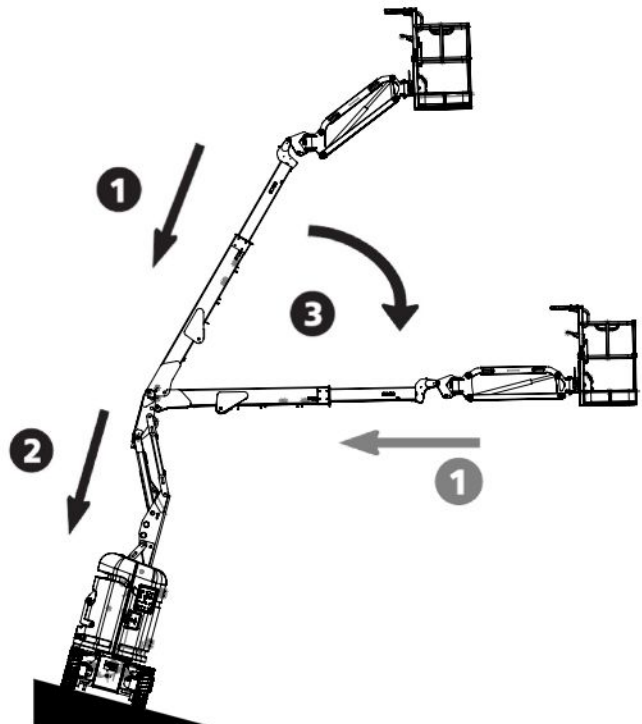

Figure 19 Platform downhill

6.3 Winching and Towing Procedure

This section provides the operator with the winching and towing procedure, which includes instructions on how to manually release the brakes.

WARNING

Ensure boom is in stowed position before winching or towing. Sudden motion could cause MEWP to become unstable. Death or serious injury could occur.

WARNING

In emergency situations where MEWP functions are not available and lowering is impeded by an obstacle, utmost care must be taken to move MEWP far enough to clear obstacle. In such cases, operation must be extremely smooth with no sudden movements and must not exceed a speed of 50 mm/sec (2 in/sec).

WARNING

When winching or towing, do not exceed 3.2 km/h (2 mph).

WARNING

Do not winch or tow MEWP on grade steeper than 35%.

WARNING

Do not winch or tow MEWP onto a slope, or brake the towing vehicle rapidly. Do not pull MEWP down an incline towards a winch.

1. Before winching or towing MEWP, fully retract, lower and position boom over rear drive wheels in line with direction of travel.

2. Manually release brakes (refer to [Section 6.3-1](#)).
3. Remove wheel chocks or blocks, and then winch or tow MEWP to desired location.
4. Position MEWP on a firm and level surface.
5. Chock or block wheels to prevent MEWP from rolling.
6. Locate disengage cap ([Figure 20](#) - item 1).
 - a. Using a 11mm (7/16") wrench, remove bolts.
 - b. Remove disengage cap and rotate to outward position (refer to [Figure 21](#)).
 - c. Reattach disengage cap and fasten bolts, using a 11mm (7/16") wrench. Brake is now re-engaged.

NOTE

Ensure o-ring remains seated.

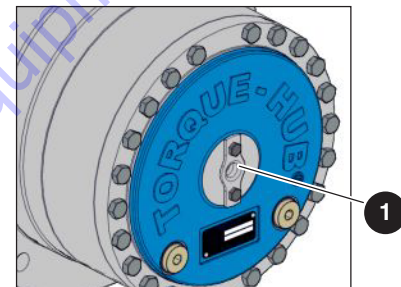

Figure 20 Disengage cap

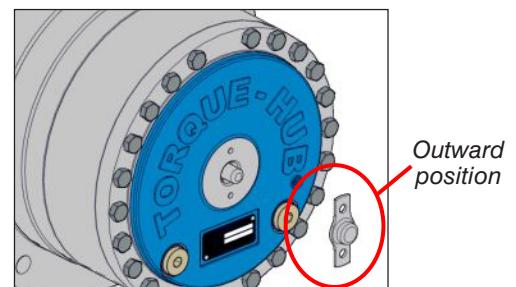

Figure 21 Disengage cap - outward position

6.3-1 Releasing brakes manually

Brakes must be manually disengaged for winching or towing.

WARNING

Do not manually disengage brakes if MEWP is on a slope.

1. Ensure MEWP is on level ground. Chock or block wheels to keep MEWP from rolling.
2. On either the left or right side of the MEWP, disconnect and lock out main power connector.

CAUTION

Do not use hydraulic power with brake disengaged.

3. Locate disengage cap ([Figure 22](#) - item 1).
 - a. Using a 11mm (7/16") wrench, remove bolts.
 - b. Remove disengage cap and rotate to inward position (refer to [Figure 23](#)).
 - c. Insert disengage cap and fasten bolts, using a 11mm (7/16") wrench. Brake is now released.

NOTE

Ensure o-ring remains seated.

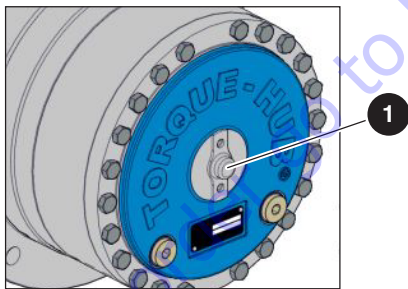

Figure 22 Disengage cap

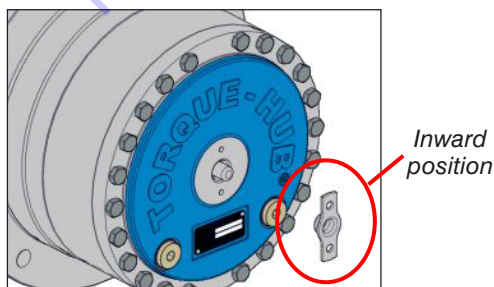

Figure 23 Disengage cap - inward position

WARNING

Brakes must be applied immediately after reaching desired location. Refer to [Section 6.3](#) on how to re-engage brakes.

6.4 Loading/Unloading

When the MEWP is loaded/unloaded from a transporting vehicle on a public road, implement measures to protect the person(s) involved or affected. These measures may include:

1. Warning cones;
2. Road signs and signalling devices;
3. Use of appropriate personal protective equipment, such as reflective clothing;
4. Flag personnel to warn other vehicles of the presence of the MEWP and any associated vehicles;
5. Or any other appropriate control measures.

Know and heed all national, state/provincial and local rules which apply to transporting of MEWPs.

Only qualified/competent personnel shall operate the MEWP during loading/unloading.

Be sure vehicle capacity and loading equipment hoists, chains, straps, etc., are sufficient to withstand maximum MEWP weight.

6.4-1 Loading and tie-down

1. Turn key switch to off position and remove key before transporting.

2. On either the left or right side of the MEWP, disconnect and lock out main power connector.
3. Chock MEWP wheels (if necessary).
4. Remove all loose items.
5. Anchor down MEWP to transport surface using tie-down points (refer to [Figure 24](#)).
6. Secure boom from side-to-side movement using lower platform mount between boom end and platform. Do not use excessive downward force when securing boom section.
7. Place block underneath platform rotator and gently lower rotator onto block and secure in place. Strap must be secured underneath hoses and cables to avoid damage to MEWP (refer to [Figure 25](#)). Do not use excessive downward force when securing platform.

WARNING

Inspect MEWP for loose or unsecured items.

NOTE

For loading and unloading using a winch line, refer to [Section 6.3](#).

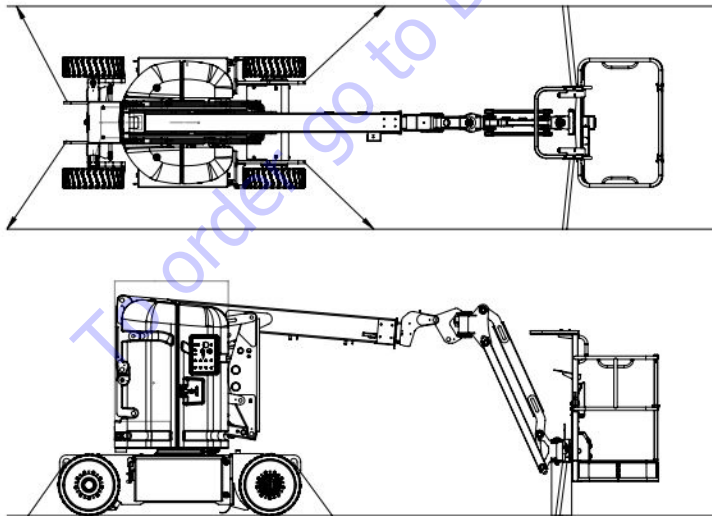

Figure 24 Tie-down points

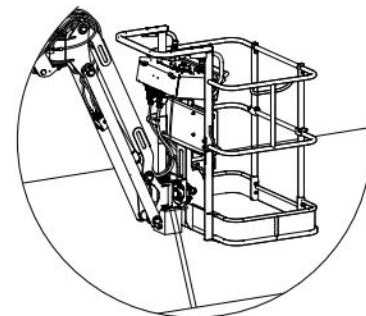

Figure 25 Platform tie-down

6.4-2 Lifting

1. Place boom in stowed position centered between drive wheels.
2. On either the left or right side of the MEWP, disconnect and lock out main power connector.
3. Clear platform of all personnel, tools and materials.

WARNING

When lifting the MEWP, lifting devices must be attached to designated lift points only (refer to [Figure 26](#)).

WARNING

Use chains of ample load capacity sufficient to withstand MEWP weight. Refer to the serial plate of the MEWP for specific weight.

4. Properly adjust rigging to ensure MEWP remains level during lifting. See Center of gravity location ([Figure 26](#)).

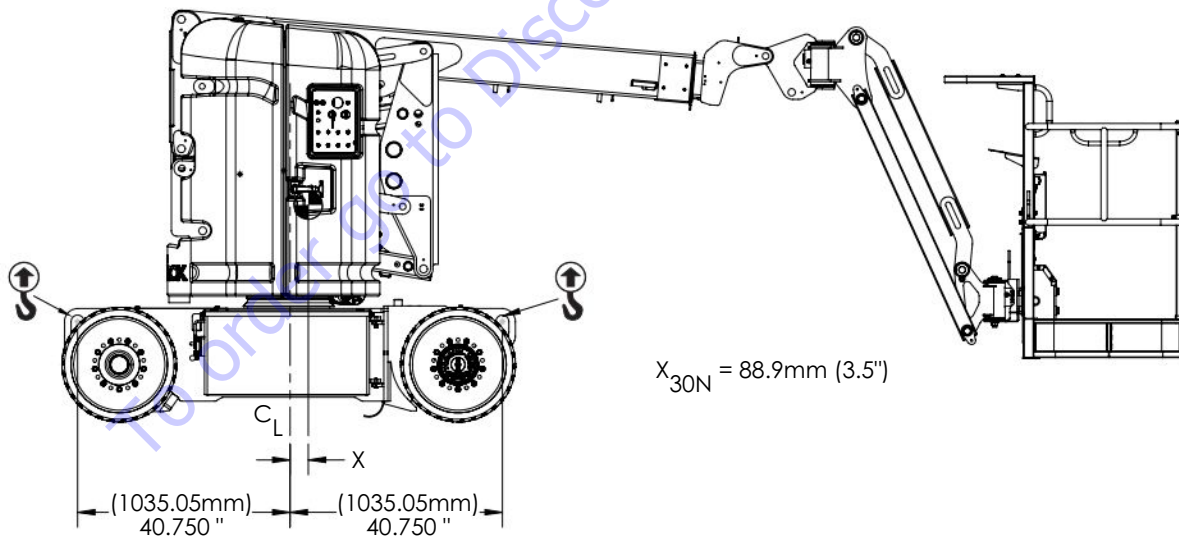

Figure 26 Lifting points/center of gravity

NOTE: Center of gravity varies with different options.

6.5 Battery Maintenance

This section provides the operator with procedures on how to service and charge the battery. This section also provides charger operation instructions.

6.5-1 Battery service procedure

⚠ WARNING

Explosion Hazard - Keep flames and sparks away. Do not smoke near batteries.

⚠ WARNING

Battery acid is extremely corrosive - Wear proper eye and facial protection as well as appropriate protective clothing. If contact occurs, immediately flush with cold water and seek medical attention.

1. On either the left or right side of the MEWP, disconnect and lock out main power connector.
2. Check battery case for damage.
3. Check battery fluid level in each battery. If plates are not covered by at least 13 mm (1/2") of solution, add distilled or demineralized water.
4. Make sure all battery connections are tight.
5. Do not use any batteries other than flooded lead-acid batteries of the proper AH rating.

⚠ WARNING

Use original or equivalent to the original parts and components for the MEWP.

6.5-2 Battery charging operation

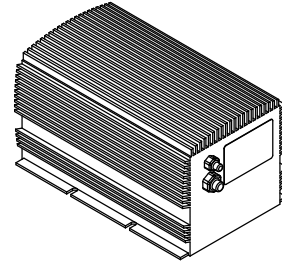

Figure 27 Battery charger

⚠ WARNING

Risk of electric shock - Do not immerse the charger in water. Though the charger is highly resistant to water, it is not designed for immersion and an electric shock can occur.

1. Provide adequate ventilation for the batteries and charger. The convection cooled design requires access to cooling air for proper operation. Do not allow blankets or other materials to cover the charger. Although the charger protects itself against overheating, the charger cooling fins should be cleaned if clogged with debris for best performance.

⚠ WARNING

There could be a spark during charging. Be careful when using fuels, solvents or other flammables near the charger or batteries.

2. Connect the power supply cord to a properly grounded 100V/50 or 60Hz, 115V/50 or 60Hz, or 230V/50 or 60Hz socket. This charger automatically senses and adjusts to the AC input voltage range.

⚠ CAUTION

When changing the input voltage wait until all the LEDs are OFF or wait a minimum of 20 seconds before switching on the new voltage.

3. The charging time is affected by numerous factors including battery Amp-Hour capacity, depth of discharge, battery temperature, and battery condition (new, old or defective). Batteries larger than 240 AH can be recharged but will take longer.

WARNING

Do not disconnect the DC output wires near the batteries when the charger is ON. The resulting arcing could cause the batteries to explode. If the charger must be disconnected, first disconnect the AC power supply cord from its outlet, then disconnect the charger DC connections.

WARNING

Risk of an electric shock - Do not touch un-insulated parts of the charger output wires, battery connector, or battery terminals.

WARNING

Visually and manually inspect to verify the DC output wires and terminals are in good working condition before each use.

4. The charger will start automatically within four to six seconds. The charger will start even with severely discharged batteries (down to 1V terminal voltage). Once charging starts, the LEDs indicate the charging progress.

6.5-3 Charging state LED

State of Charging	1 st LED	2 nd LED	3 rd LED
0 to 50 %	Blinking	Off	Off
50% to 75%	On	Blinking	Off
75% to 100%	On	On	Blinking
100%	On	On	On

The charger goes into an equalizing charge mode after the batteries are charged and all 3 LEDs are “ON”. The charger will continue to charge at a low current then shut off automatically when complete. If all 3 LEDs blink together, there is a problem.

Take proper action according to the following instructions:

- **3 LEDs blink once simultaneously:** Output connection error. Check the battery and charger connection. The output may not be connected to the batteries or the connections to the batteries may have corroded or loosened. The output may be shorted due to improper connection to the batteries or pinched wires. The output may be connected in reverse polarity to the batteries. The charger is not damaged by any of these problems.
- **3 LEDs blink twice simultaneously:** The charger is indicating that the AC voltage is too low or too high. Check the AC input voltage.
- **3 LEDs blink three times simultaneously:** Charger is overheated. No action required. When the charger cools, charging will restart automatically. Check for and remove dirt or other debris on charger that may be reducing cooling.
- **3 LEDs blink four times simultaneously:** Input or output over current. No action required, charger will correct and restart automatically.
- **100% LED lamp blinks:** Charger 18-hour timer has timed out due to battery problem.
- **Batteries do not fully charge:** If the batteries are charged overnight, make sure the AC supply is not being switched off at night with other building items. Check battery condition and for dead cells or reduced capacity. Replace charger only if other problems are not found.
- **The AC line circuit breaker or fuse is blown:** A defective circuit breaker or fuse, an overloaded circuit, or a charger problem can cause this condition. Try connecting the charger to a different AC outlet (on a different circuit) in the building. If the AC supply checks good, the charger should be replaced.

Section 7 – Technical Drawings and Specifications

To order go to Discount-Equipment.com

7.1 Technical Diagrams

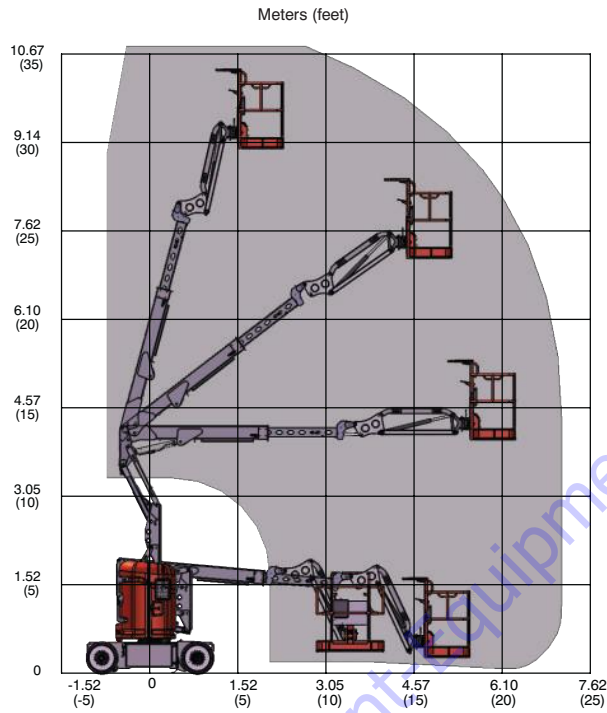

Figure 28 Reach diagram - SJ30 AJE

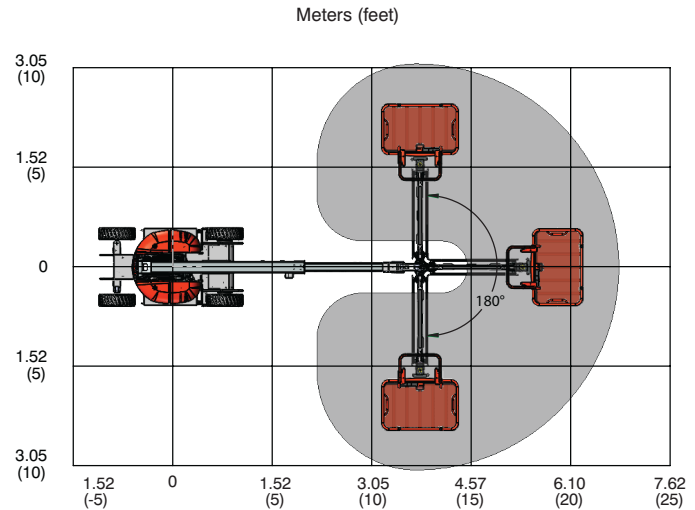
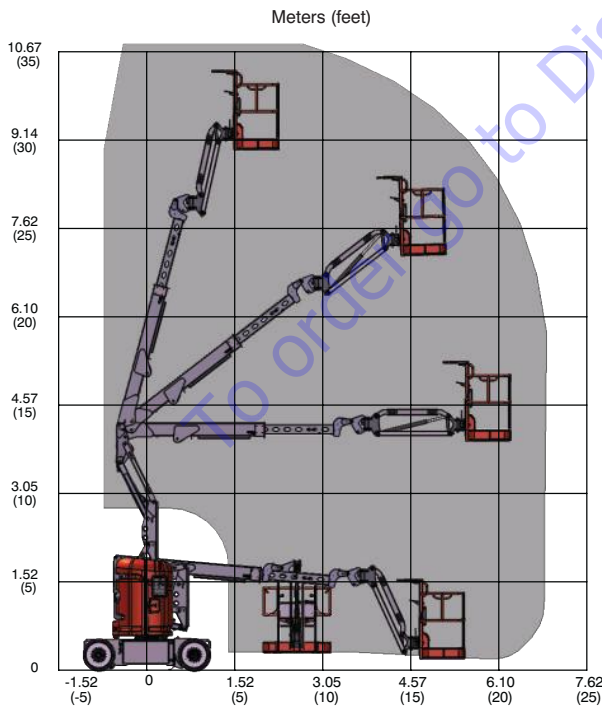

Figure 29 Reach diagrams - SJ30 ARJE

Technical Diagrams Continued

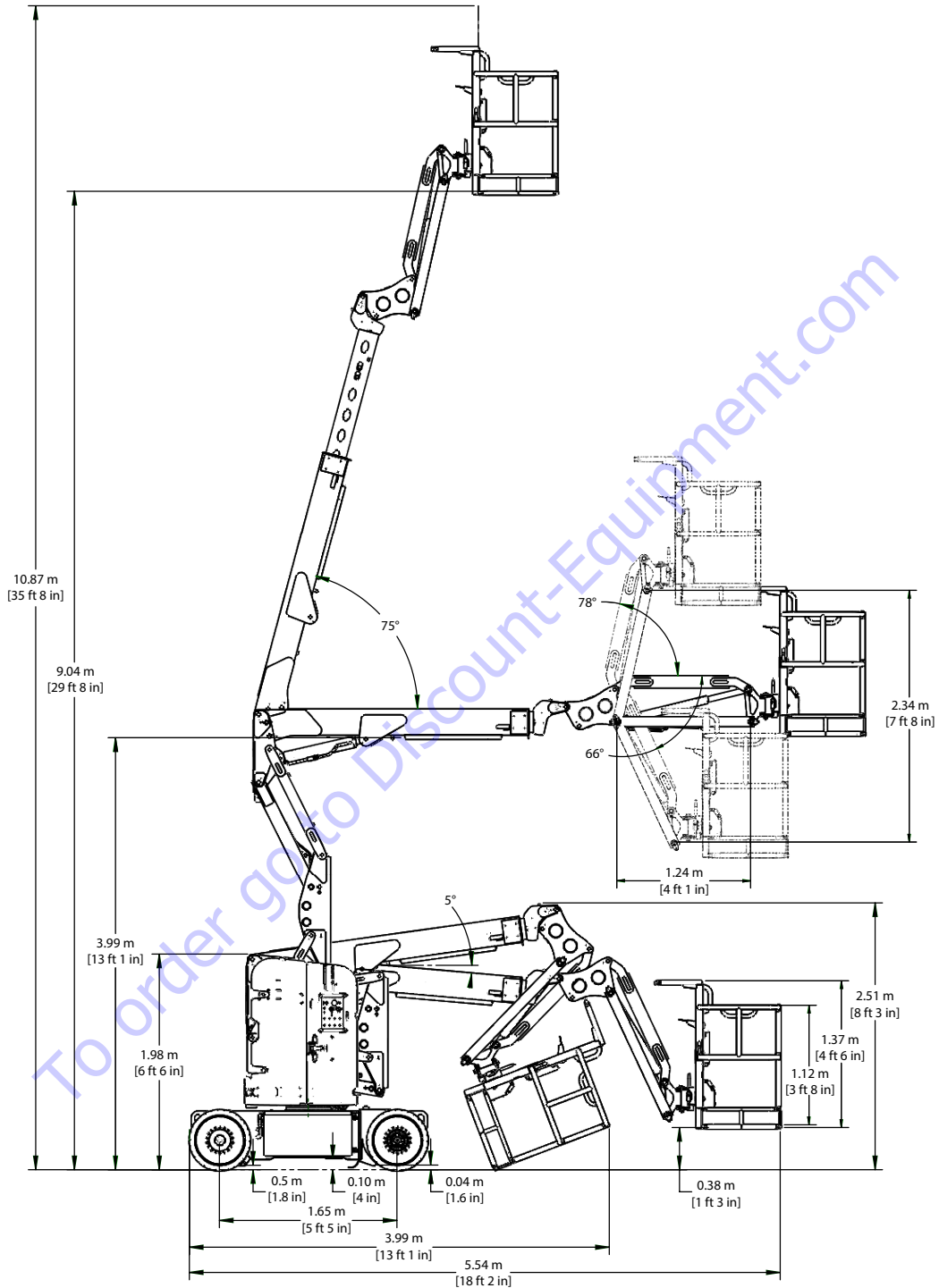

Figure 30 Dimensions - SJ30 AJE

Technical Diagrams Continued

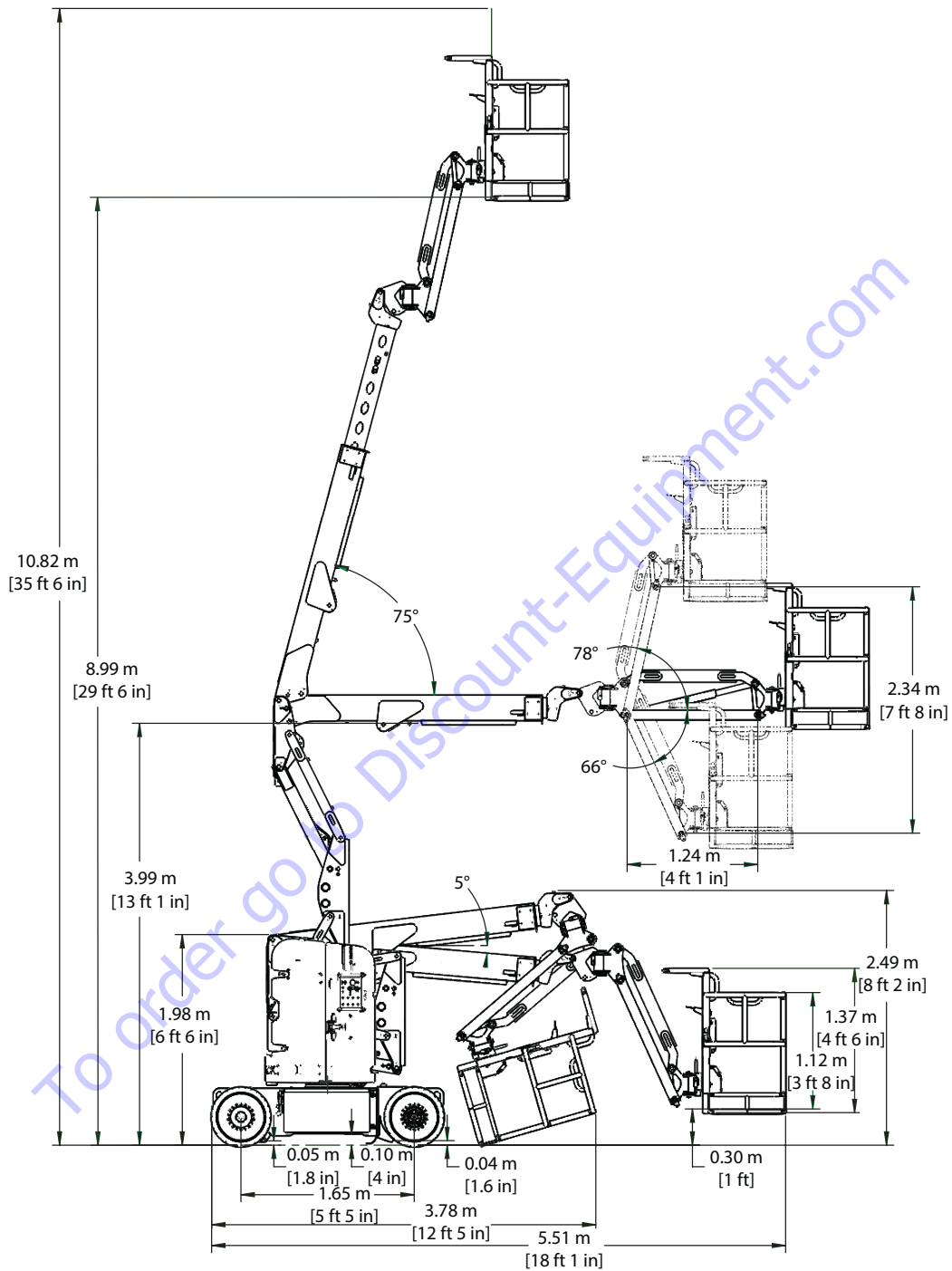

Figure 31 Dimensions - SJ30 ARJE

Technical Diagrams Continued

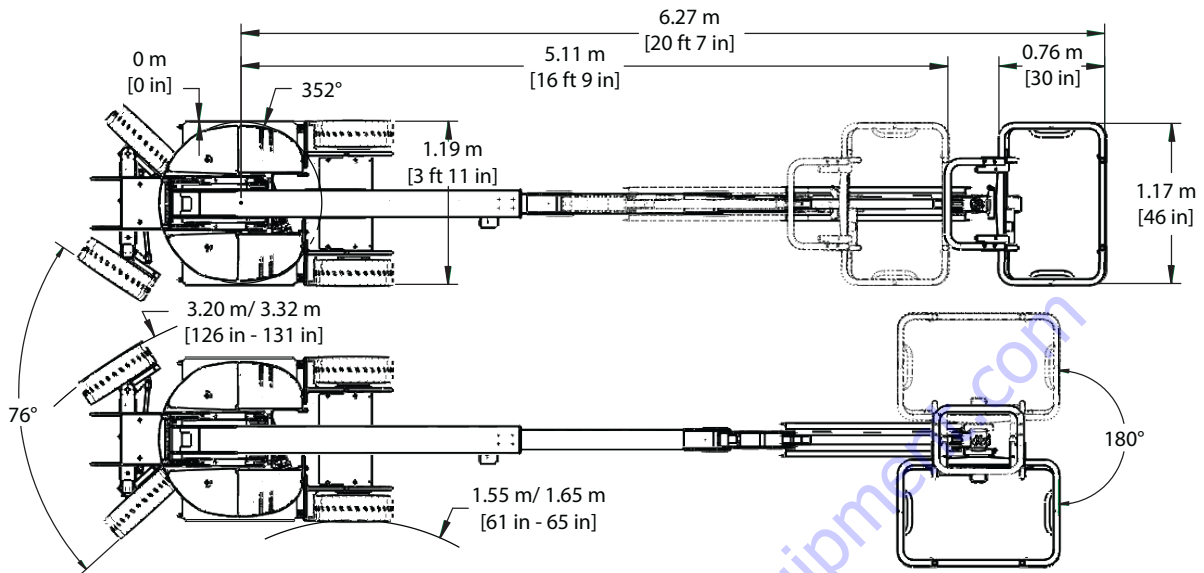

Figure 32 Dimensions - SJ30 AJE

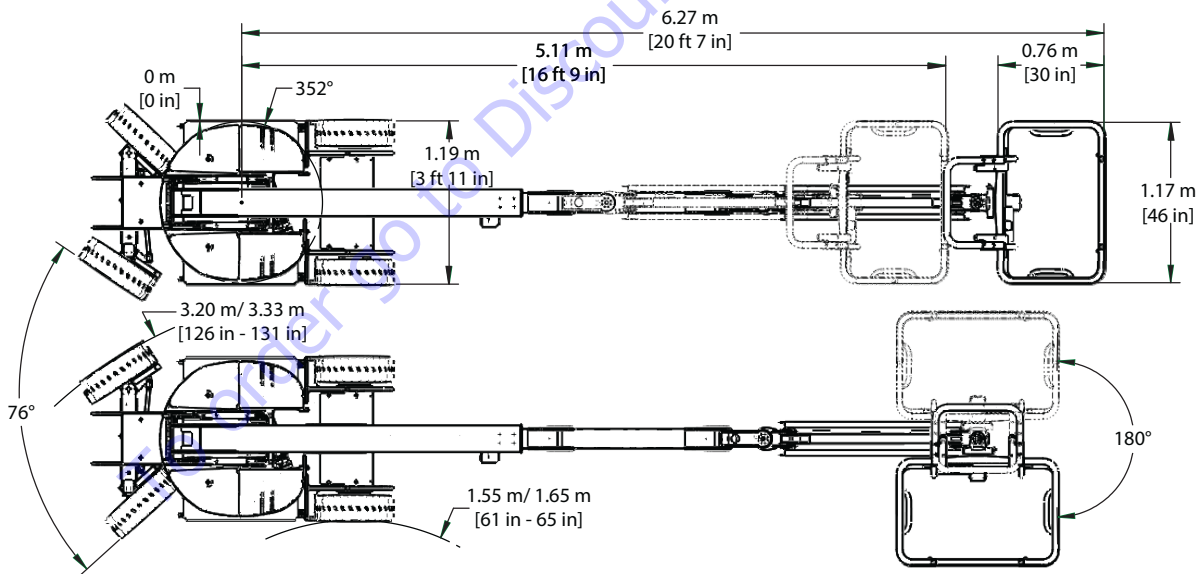

Figure 33 Dimensions - SJ30 ARJE

7.2 Standard and Optional Equipment

Models	SJ30 AJE/ SJ30 ARJE
Standard Equipment	
24-Volt DC emergency power	✓
1.2 m (4 ft) jib	✓
Base controls	✓
Platform controls	✓
Continuous drive and steer directional sensing	✓
Four-wheel drive	✓
Manual brake release	✓
Operator horn	✓
0.76 m X 1.17 m (30 in x 46 in) platform (drop bar)	✓
Spring-applied hydraulically released brake	✓
Variable speed drive and function controls	✓
Pothole protection device	✓
Hourmeter	✓
Fall protection anchorages	✓
Battery warning light	✓
Solid rubber, non-marking tires	✓
Secondary Guarding Electrical (SGE)	✓
AC outlet on platform	✓
All motion alarm	✓
Optional Equipment	
Air line to platform	✓
0.76 m X 1.17 m (30 in x 46 in) platform (swing gate)	✓
Flashing amber light	✓
Platform work light	✓
Bio oil	✓
Tool tray	✓
Pipe rack	✓
1.5kW Pro-charger	✓
Inverter	✓
Control box cover	✓
Elevate telematics - access control unit	✓

1418AA_ANSI

7.3 Owner's Annual Inspection Record

The decal form features the SKYJACK logo at the top left. To its right are fields for 'Model' and 'SN'. Below these is a grid with 11 columns. The first column contains a date field with the number '31' and a pencil icon. The second column contains the number '20'. The remaining nine columns each contain a '20' and a small icon of a scissor assembly. Below the grid is a signature line with a magnifying glass icon and a person icon, and a checkmark icon. The SKYJACK logo is also printed vertically in the first column of the grid.

SKYJACK		Model _____		SN _____						
31	20	20	20	20	20	20	20	20	20	20
Inspector signature	SKYJACK									

Figure 34 This decal is located on the scissor assembly. It must be completed after an annual inspection has been completed. Do not use the MEWP if an inspection has not been recorded in the last 13 months.

To order go to Discount-Equipment.com

7.4 Specifications and Features-A

Models		SJ30 AJE	SJ30 ARJE
Platform Size	Total platform length (outside)	1.17 m (46 in)	
	Total platform depth (outside)	0.76 m (30 in)	
Height	Working	11 m (36 ft)	
	Platform elevated	9 m (30 ft)	
	Drive	Drivable at all heights	
	Stowed	1.98 m (6 ft 6 in)	
Overall length		5.54 m (18 ft 2 in)	5.51 m (18 ft 1 in)
Overall width		1.19 m (3 ft 11 in)	
Weight		5588 kg (12,320 lb)	
Platform rotation		180 degrees	
Jib rotation		N/A	180 degrees
Horizontal reach		5.11 m (16 ft 9 in)	
Horizontal reach @ maximum height		6.27 m (20 ft 7 in)	
Wheelbase		1.65 m (5 ft 5 in)	
Turret rotation		352 degrees continuous	
Turret tailswing		0 m (0 in)	
Gradeability		35%	
Ground clearance under axle		0.10 m (4 in)	
Turning Radius	Inside (left - right)	1.55 m - 1.65 m (61 in - 65 in)	
	Outside (left - right)	3.20 m - 3.33 m (126 in - 131 in)	
Battery voltage		48V DC	
Battery type		Lead/Acid	
Operating Times	Main boom up	20 - 24 seconds (approx.)	
	Main boom down	18 - 20 seconds (approx.)	
	Riser boom up	14 - 18 seconds (approx.)	
	Riser boom down	22 - 26 seconds (approx.)	
	Fly boom extend	17 - 19 seconds (approx.)	
	Fly boom retract	12 - 16 seconds (approx.)	
	Jib up	18 - 20 seconds (approx.)	
	Jib down	12 - 16 seconds (approx.)	
	Jib swing	14 - 16 seconds (approx.)	
	Turret rotate	70 - 90 seconds (approx.)	
Platform rotate	7 - 10 seconds (approx.)		
Driving Speeds	Drive speed (maximum-stowed)	4.8 km/h (3.0 mph)	
	Drive speed (maximum-elevated)	0.6 km/h (0.4 mph)	

1419AA_ANSI

7.5 Specifications and Features-B

SJ30 AJE/ SJ30 ARJE	
Electromagnetic Compatibility (EMC)	Meets EN13309:2010 requirements
Hazardous Location Rating	MEWP not rated for hazardous locations
Operating Temperatures	
Standard	-20°C (-4°F) to +40°C (+104°F)

1421AA_ANSI

7.6 Tire/Wheel Specifications

SJ30 AJE/ SJ30 ARJE	
Tire Size	559 mm x 178 mm (22.0 in x 7.0 in)
Type	Solid Rubber
Wheel Nuts Torque	244 Nm (180 ft-lb)

1422AA_ANSI

7.7 Maximum Platform Capacities

SJ30 AJE/ SJ30 ARJE	Indoor	Outdoor
Total Capacity	227 kg (500 lb)	
	2 Persons	1 Person
Maximum Wind	0 m/s (0 mph)	12.5 m/s (28 mph)
Maximum Side Force	400 N (90 lbf)	200 N (45 lbf)
Tilt Cutout Setting	2 degrees x 3 degrees	

1423AA_ANSI

7.8 Floor Loading Pressure

Models	Gross MEWP Weight		Total MEWP Load					
			Wheel		LCP		OUP	
	kg	lb	kg	lb	kPa	psi	kPa	psf
SJ30 AJE	5,815	12,820	3,255	7,180	1,503	218	21.6	451
SJ30 ARJE								

1424AA_ANSI

- Gross MEWP Weight = Weight + platform capacity
- LCP – Locally Concentrated Pressure – is a measure of how hard the MEWP tire tread presses on the area in direct contact with the floor. The floor covering (tile, carpet, etc.) must be able to withstand more than the indicated values above.
- OUP – Overall Uniform Pressure – is a measure of the average load the MEWP imparts on the whole surface projected directly underneath it. The structure of the operating surface (beams, etc.) must be able to withstand more than the indicated values above.

NOTE

The LCP or OUP that an individual surface can withstand varies from structure to structure and is generally determined by the engineer or architect for that particular structure.

To order go to Discount-Equipment.com

7.8-1 Locally concentrated pressure (LCP)

Foot print area identified by test.

$$LCP = \frac{\text{Wheel load}}{\text{Foot print area}}$$

7.8-2 Overall uniform pressure (OUP)

Base area = length x width

$$OUP = \frac{\text{Weight of MEWP + capacity}}{\text{Base area}}$$

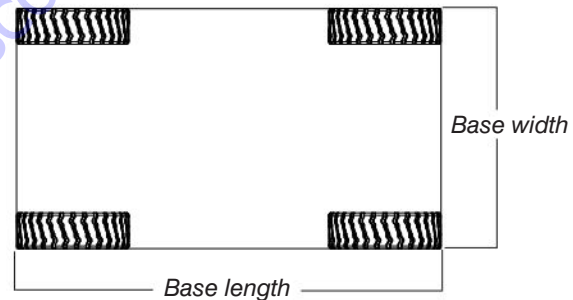
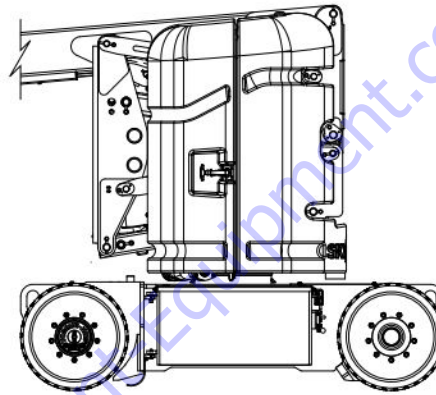
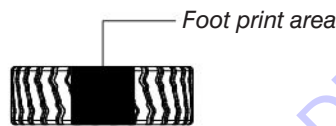
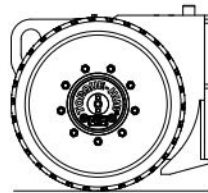

⚠ WARNING

Do not use tires other than those specified for this machine. Do not mix different types of tires. Tires other than those specified can adversely affect stability. Failure to operate with matched, approved tires in good condition may result in death or serious injury. Replace tires with the exact, Skyjack-approved types only.

Section 8 – Labels

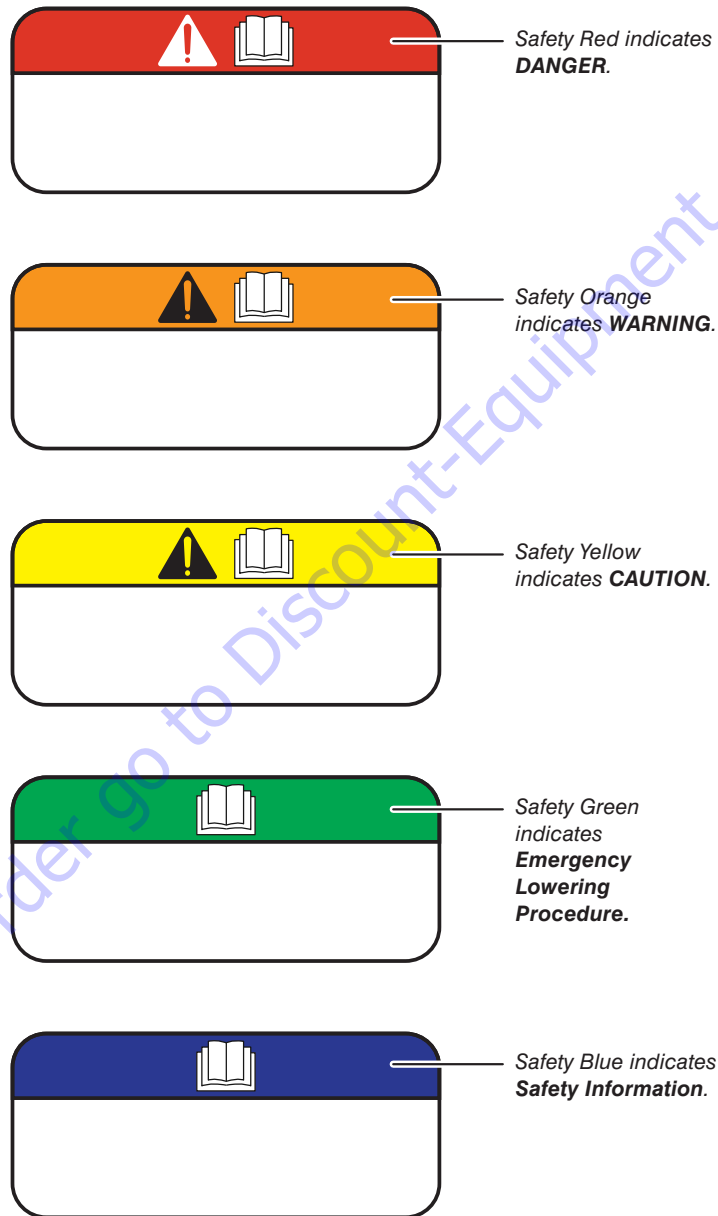
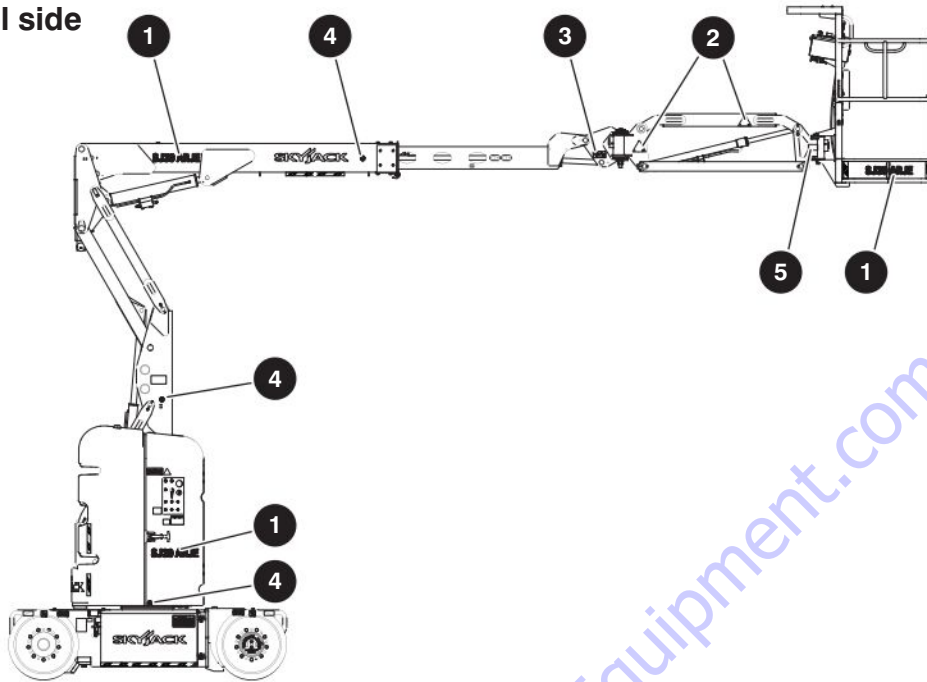

Figure 35 Label legend

8.1 SJ30 AJE & SJ30 ARJE Labels





8.1-1 Control side

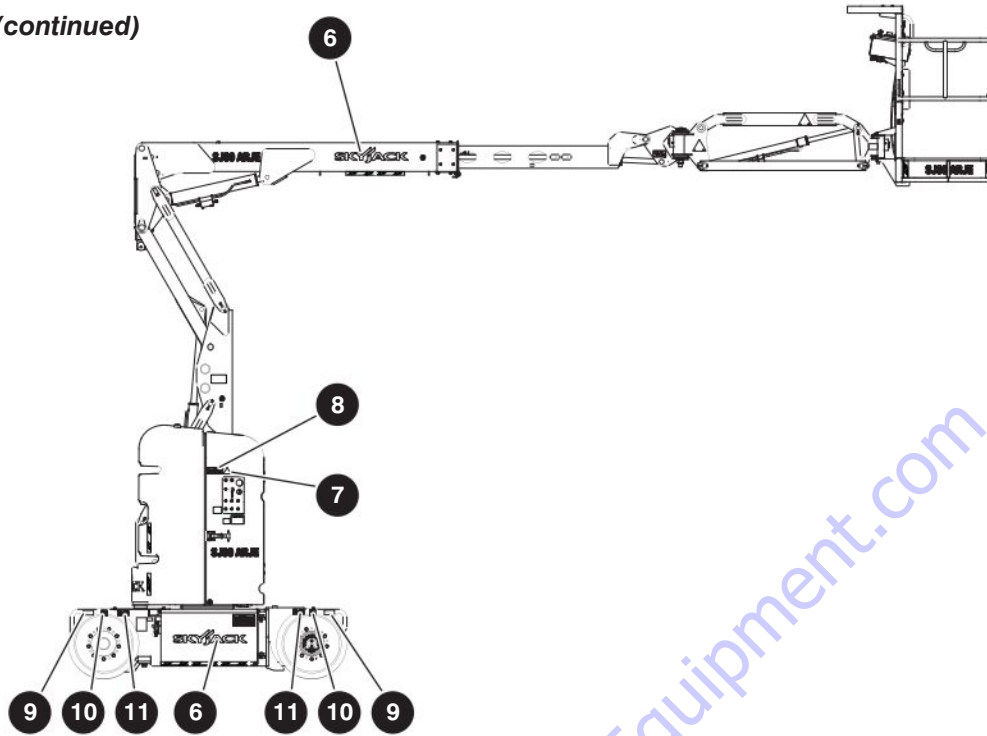

Description	Label Pictorial
<p>1 Model number* Product Identifier <i>*Model number will vary, may not be as shown.</i></p>	<p>SJ30 AJE</p> <hr/> <p>SJ30 ARJE</p>
<p>2 Body crushing hazard Warning - Body crushing hazard</p>	
<p>3 Crushing hazard Warning - Crushing hazard</p>	
<p>4 Warning - Do not alter Do not alter or disable limit switches or other safety devices.</p>	
<p>5 Tie down points Only use these points for tying down.</p>	

Control side (continued)

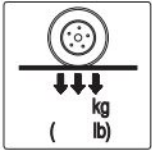
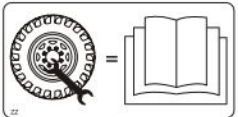

Description	Label Pictorial
<p>6 Skyjack logo Skyjack</p>	
<p>7 Warning - Annual inspection Refer to operating manual. Ensure Annual and Daily Inspections are performed.</p>	
<p>8 Annual inspection Ensure that MEWP has received annual inspection prior to operation.</p>	
<p>9 Lift and tie down points Only use these points for lifting or tying down.</p>	
<p>10 Wheel load* Indicates rated wheel load. <i>*Wheel load will vary over different MEWPs.</i></p>	
<p>11 Wheel specifications Refer to manual for wheel type, offset, pressure and torque.</p>	

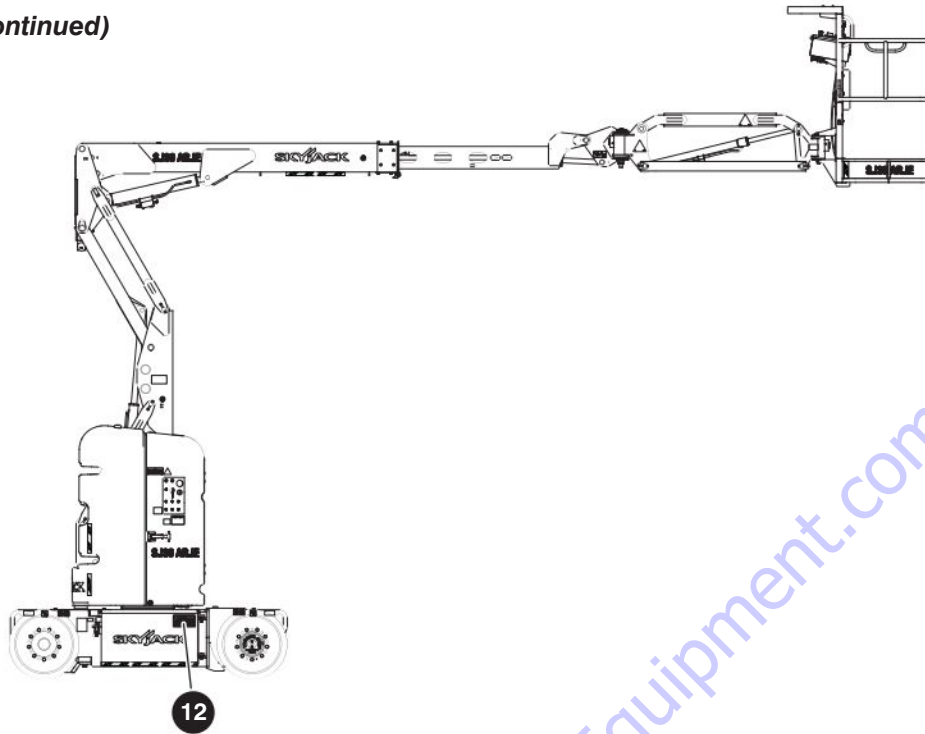
Control side (continued)

Description

Label Pictorial

12 Winching & towing procedure

Refer to operating manual.

1. Block or chock wheels to prevent MEWP from rolling.
2. On either the left or right side of the MEWP, disconnect and lock out main power connector.
3. Locate disengage cap on torque-hub at rear of base.
4. Using a 11mm (7/16") wrench, remove bolts.
5. Remove disengage cap and rotate to inward position. Insert disengage cap and fasten bolts.
6. Brake is now released.
7. Remove blocks/chocks from wheels and winch/tow to desired location.
8. Block or chock wheels to prevent MEWP from rolling.
9. Re-engage brake by performing the following steps:
 - a. Using a 11mm (7/16") wrench, remove bolts.
 - b. Remove disengage cap and rotate to outward position.
 - c. Reattach disengage cap and fasten bolts.
10. Brake is now re-engaged. On both the left and right sides of the MEWP, plug in main power connectors.

**NOTE**

Before operation, ensure all blocks are removed from wheels.

Control side (continued)

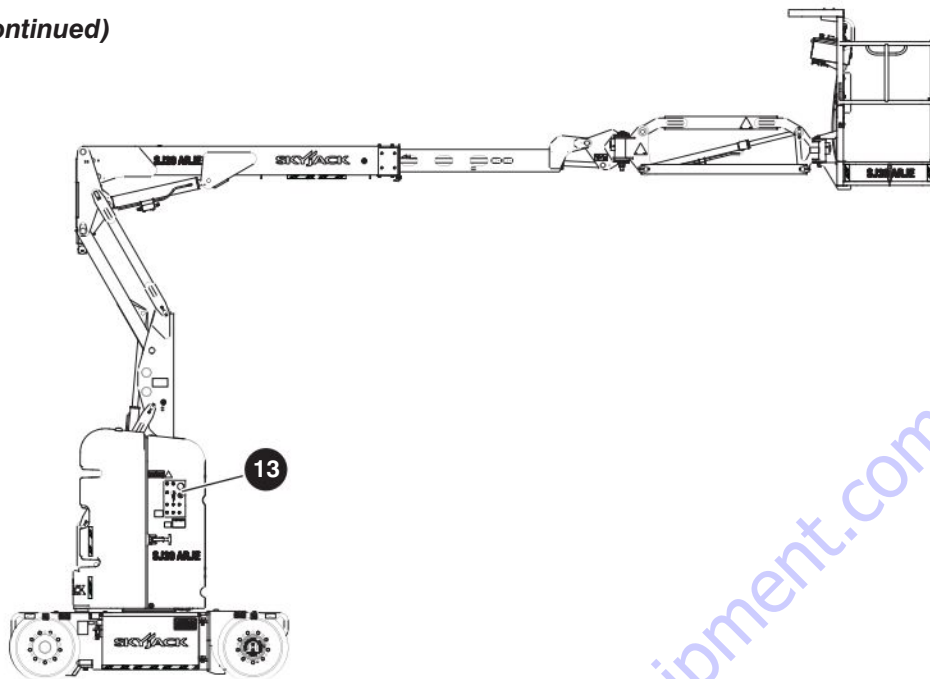

Description	Label Pictorial
-------------	-----------------

13 Base control console

Push and hold function enable switch to enable base control functions.

Push ground circuit breaker to reset.

Push power circuit breaker to reset.

Read operating manual.

Push and hold emergency power switch to enable the emergency power unit for emergency descent.

Push emergency stop button to disable controls.

Select off position to disable controls, base position to enable base control console or platform position to enable platform control console.

Select jib rotation switch to rotate jib to the left or right.

Select jib up/down switch to move jib up or down.

Select boom extend switch to extend or retract fly boom.

Select riser raise/lower switch to raise or lower riser.

Select platform rotation switch to rotate platform to the left or right.

Select platform leveling override switch to tilt platform up or down.

Select boom raise/lower switch to raise or lower main boom.

Select turret rotation switch to rotate turret to the left or right.

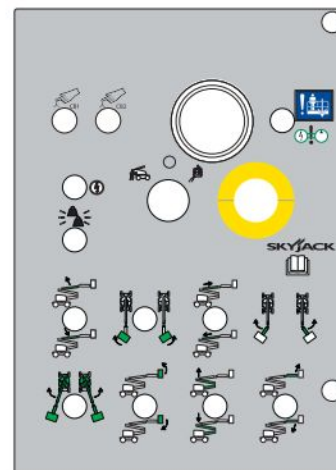

Control side (continued)

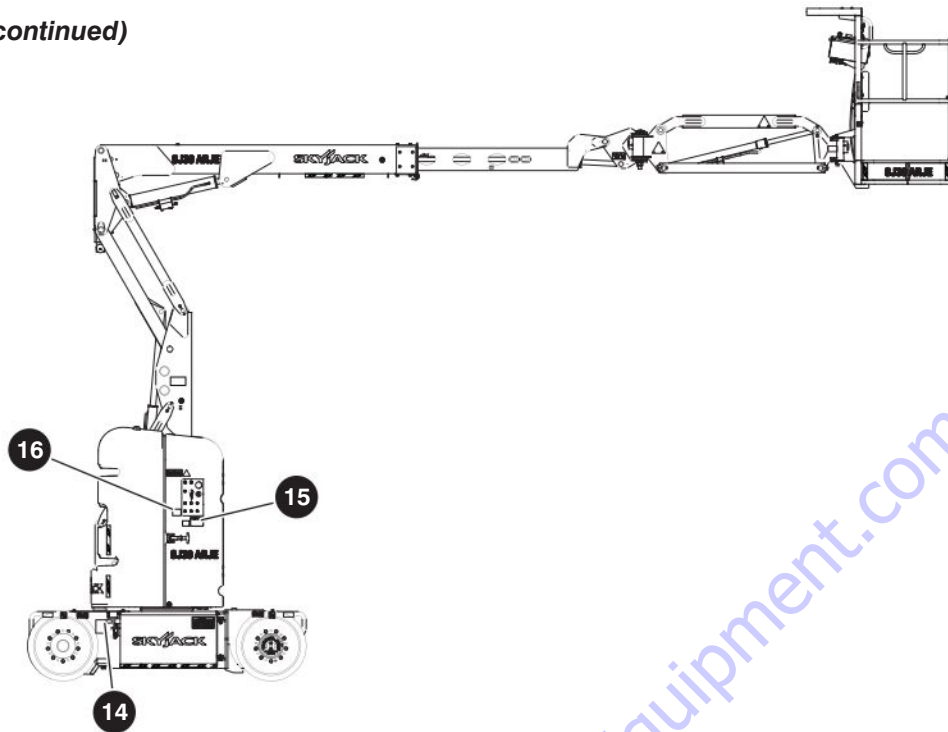

Description

Label Pictorial

14 Serial plate*

Product identification and specifications

**Serial plates will vary, may not be as shown.*

Mobile Elevating Work Platform			
This MEWP has been designed and tested to the following requirements: ANSI/SAA A92.28-2003 and CAN/CSA-B254.6:17			
SKYJACK		Made in Canada	
Model number	Type	Group	Serial number
SJ30			
Indoor use	Capacity and maximum number of persons kg = _____ lb = _____ persons + equipment		
Max. work platform height	Max. wind speed	Max. manual force	
m _____ ft _____	m/s _____ mph _____	N _____ lb _____	
Outdoor use	Capacity and maximum number of persons kg = _____ lb = _____ persons + equipment		
Max. work platform height	Max. wind speed	Max. manual force	
m _____ ft _____	m/s _____ mph _____	N _____ lb _____	
Machine weight	Voltage	Max. incline	
kg _____ lb _____	V _____	° _____	
System pressure	bar _____ psi _____		
Model year	_____		
Year of manufacture	_____		
Skyjack Inc. 55 Campbell Road, Guelph, Ontario N1H 1S9 Canada			

15 Emergency lowering procedure

Refer to operating manual.

1. Pull out emergency stop button.
2. Select base position from key switch.
3. Move and hold emergency power switch up or down and activate desired boom function.

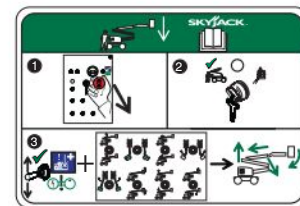

16 Emergency lowering identification



Control side (continued)

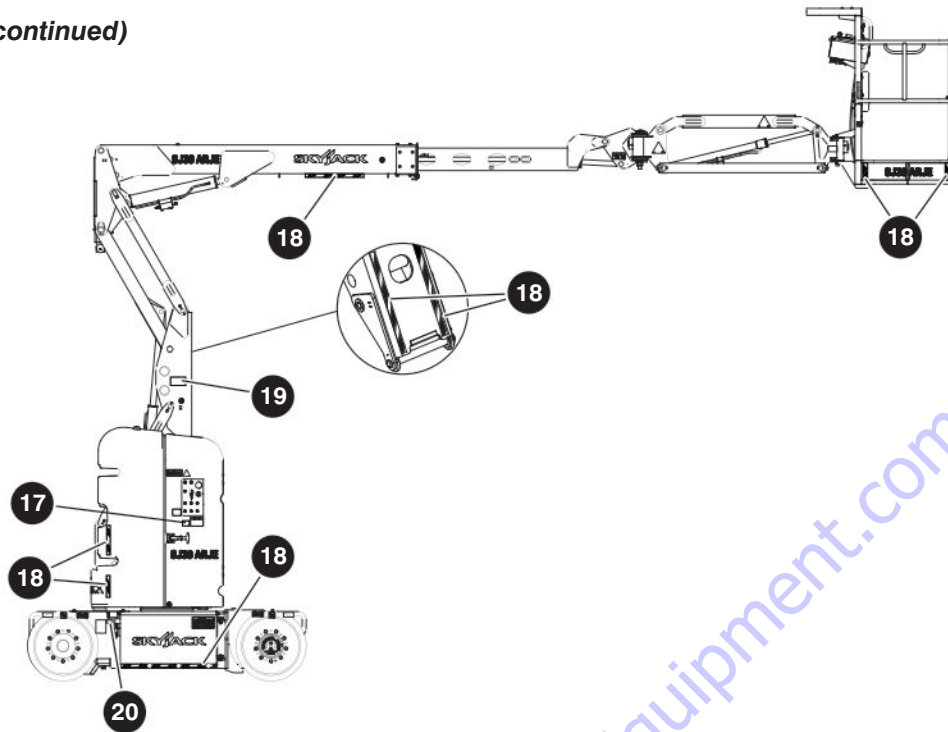

Description	Label Pictorial
<p>17 Elevate - Powered by Trackunit (if equipped) This MEWP is equipped with additional functionality.</p>	
<p>18 Caution tape stripe</p>	
<p>19 Warning - Maintenance support Do not enter the space beneath the work platform or extending structure during maintenance unless a means of structure support is in place. Refer to service manual for instructions regarding machine power isolation and structure support during maintenance.</p>	
<p>20 Skyjack manufactured date</p>	

Control compartment

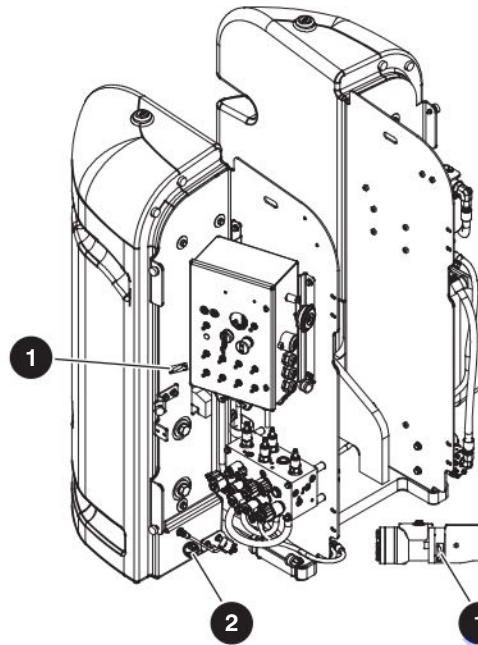

Description

Label Pictorial

1 Grease points maintenance

Refer to service and maintenance manual for lubricating MEWP.



2 Warning - Do not alter

Do not alter or disable limit switches or other safety devices.



8.1-2 Front side

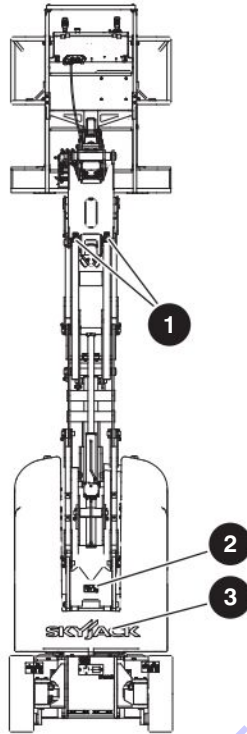

Description

Label Pictorial

1 Crushing hazard
Warning - Crushing hazard



2 Crushing hazard
Warning - Crushing hazard



3 Skyjack logo
Skyjack



Front side (continued)

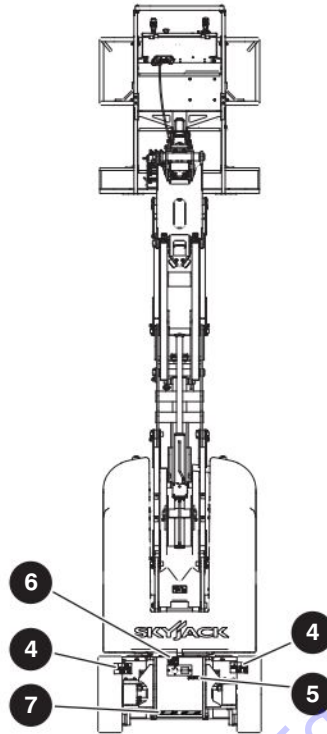

Description	Label Pictorial
<p>4 Main power connector Disconnect and lock out to disconnect power to all circuits. Plug in to base to operate any circuit.</p>	
<p>5 Connect AC supply Connect AC supply here.</p>	
<p>6 Battery charging connection Refer to operating manual. Connect AC supply here to charge batteries.</p>	
<p>7 Caution tape stripe</p>	

8.1-3 Top view

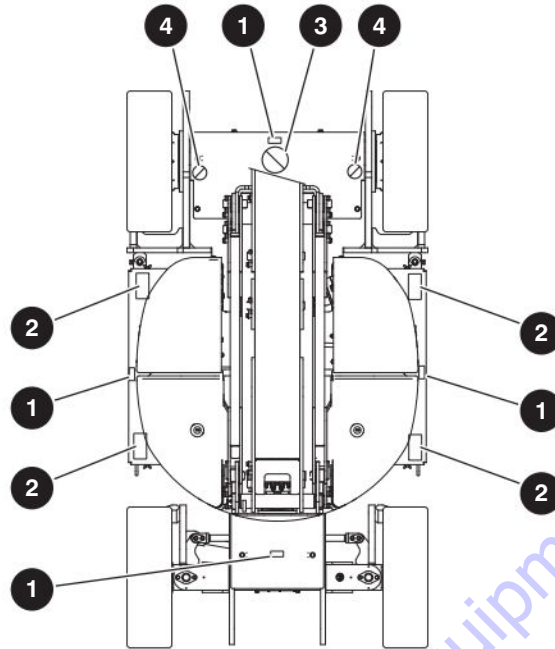

Description	Label Pictorial
<p>1 Warning - No step No step warning</p>	
<p>2 Crushing hazard Warning - Crushing hazard</p>	
<p>3 Warning - Electrical shock Stay away. High voltage (48V).</p>	
<p>4 Warning - Electrical shock Stay away. High voltage.</p>	
<p>5 Warning - Do not alter Do not alter or disable limit switches or other safety devices.</p>	

8.1-4 Platform views

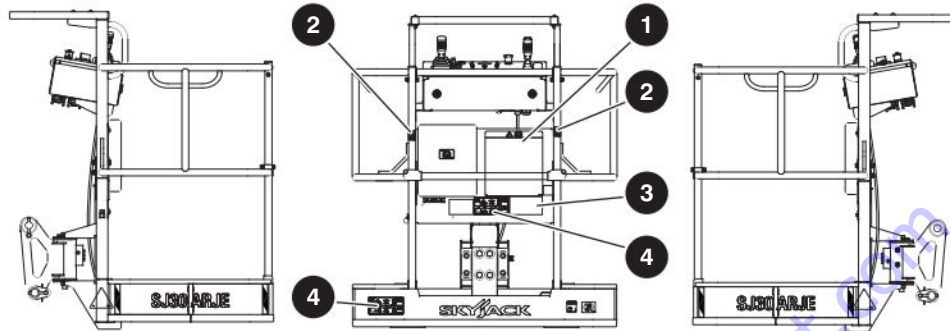

Description	Label Pictorial
<p>1 Hazard identification</p> <p>Refer to Section 2: Operator Safety. Read and understand outlined risks associated with this MEWP prior to operation.</p>	
<p>2 Fall protection anchorage</p> <p>Attach personal Fall protection lanyard of each occupant to fall protection anchorage point.</p> <p>Rated for one (1) person per anchorage.</p> <p>Used for fall restraint or fall arrest.</p>	
<p>3 IPAF “Click It!”</p> <p>Indicates full body harness awareness.</p>	
<p>4 Platform capacity*</p> <p>Rated work load when operating on level ground. Rated work load includes the weight of both personnel and material, and maximum number of people in each configuration. Do not exceed total weight or maximum number of people. Load platform uniformly.</p> <p><i>*Platform capacity will vary over different MEWPs.</i></p> <p>Horizontal load rating</p> <p>Apply no more than indicated side load. Operate below indicated wind speed only.</p>	

Platform views (continued)

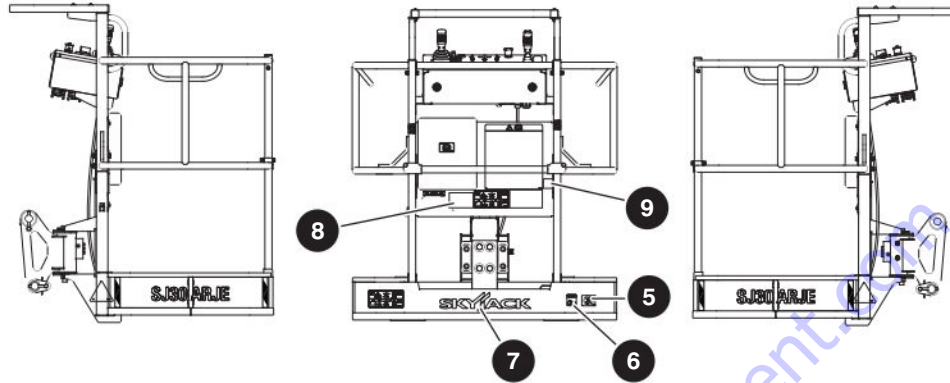

Description	Label Pictorial
<p>5 No jewelry Caution - Do not wear jewelry.</p>	
<p>6 Operator's daily inspection Refer to the operating manual. Perform visual inspection and function tests at the beginning of each shift. Refer to Section 4.4: Operator's Checklist.</p>	
<p>7 Skyjack logo Skyjack</p>	
<p>8 Warning - California proposition 65 Cancer and Reproductive Harm- https://www.p65warnings.ca.gov/.</p>	
<p>9 No insulation This MEWP is not electrically insulated. Maintain a Minimum Safe Approach Distance (MSAD) from energized power lines and parts.</p>	

Platform views (continued)

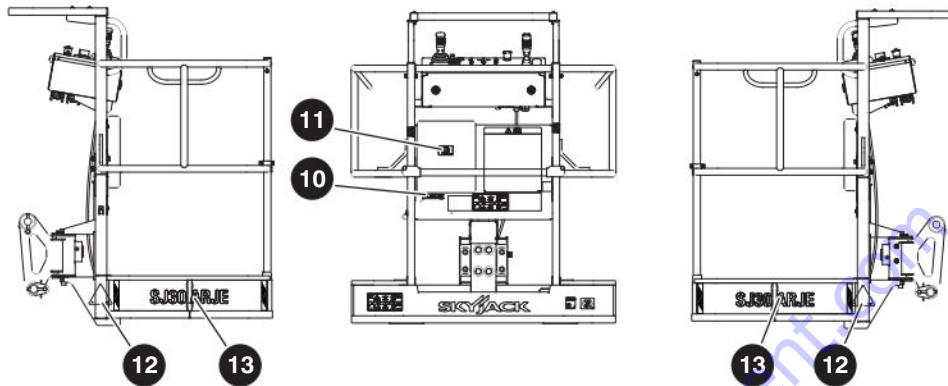

Description	Label Pictorial
<p>10 Connect AC supply Connect AC supply here.</p>	
<p>11 Manual box Indicates location of operating manual.</p>	
<p>12 Body crushing hazard Warning - Body crushing hazard.</p>	

SJ30 AJE

13 Model number*
Product Identifier
**Model number will vary, may not be as shown.*

SJ30 ARJE

Platform - top view

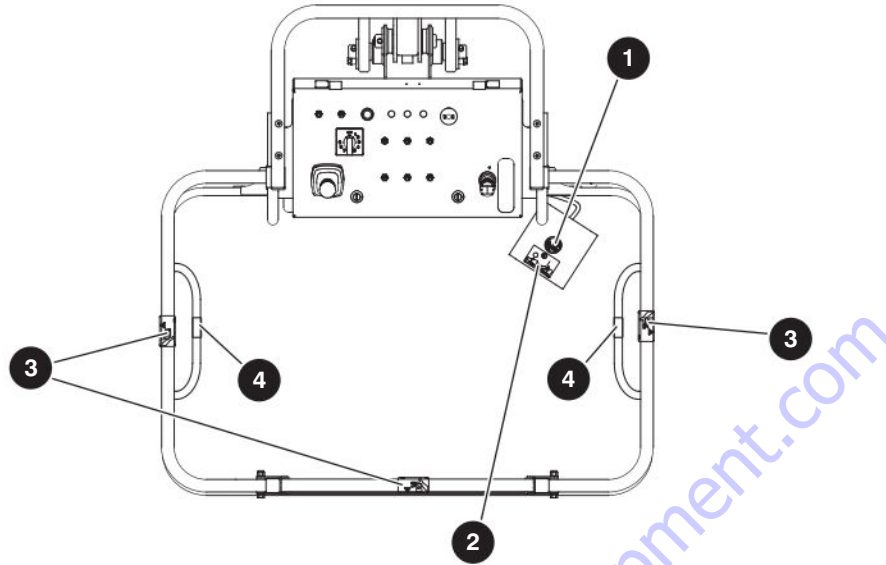

Description	Label Pictorial
<p>1 Warning - Do not alter Do not alter or disable limit switches or other safety devices.</p>	
<p>2 Footswitch enable (on/off) Depress and hold footswitch to enable platform function.</p>	
<p>3 Crushing hazard Warning - Crushing hazard</p>	
<p>4 Warning - No step No step warning</p>	

Platform control console

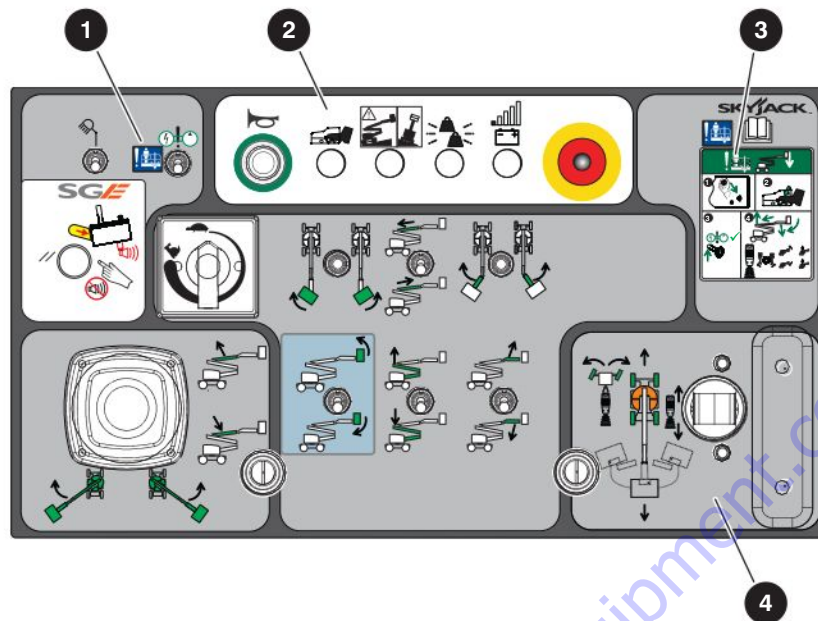

Description	Label Pictorial
<p>1 Work light (if equipped)/Emergency power unit/SGE reset</p> <p>Select work light switch to enable work light (if equipped).</p> <p>Select emergency power switch to enable emergency power unit.</p> <p>Select SGE reset button to reset SGE.</p>	
<p>2 Horn/Emergency stop</p> <p>Select horn pushbutton to sound horn.</p> <p>Push emergency stop button to disable controls.</p>	
<p>3 Emergency lowering procedure</p> <p>Refer to operating manual.</p> <ol style="list-style-type: none"> 1. Pull out emergency stop button. 2. Depress and hold footswitch. 3. Turn emergency power switch to on position. 4. Activate desired boom function to lower platform. 	
<p>4 Drive/Steer controller</p> <p>Press rocker switch to steer left or right.</p> <p>Push and hold controller to drive forward or backward.</p>	

Platform control console (continued)

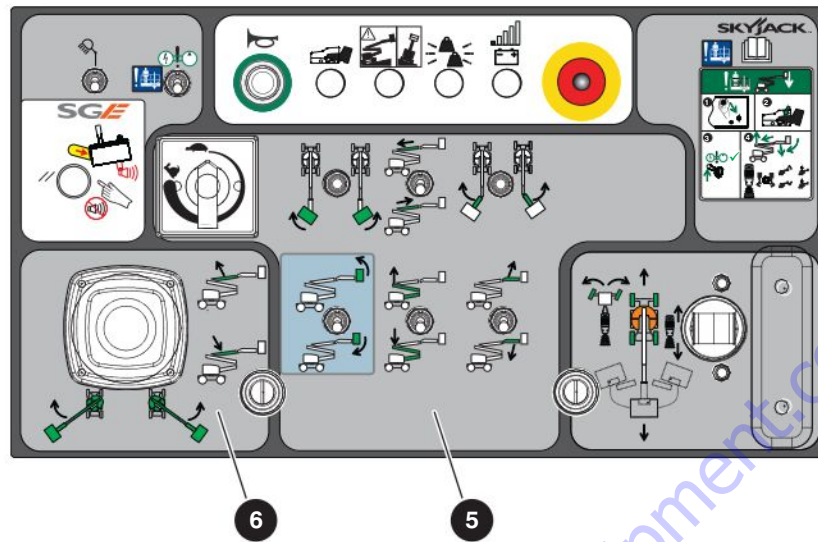

Description	Label Pictorial
-------------	-----------------

5 Boom speed adjuster dial/Platform/Boom/Jib controls

- Adjust dial to vary speed of fly boom extension/retraction, jib raising/lowering and platform rotation movements.
- Select platform rotation switch to rotate platform to the left or right.
- Select boom extend/retract switch to extend or retract fly boom.
- Select jib rotation switch to rotate jib to the left or right.
- Select platform leveling override switch to tilt platform up or down.
- Select riser raise/lower switch to raise or lower riser.
- Select jib up/down switch to move jib up or down.

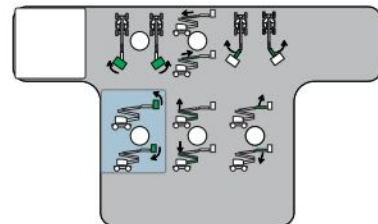

6 Boom/Turret controller

- Push and hold controller to rotate turret to the left or right.
- Push and hold the controller to raise or lower main boom.

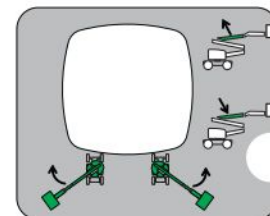

8.1-5 Motor/Hydraulic side

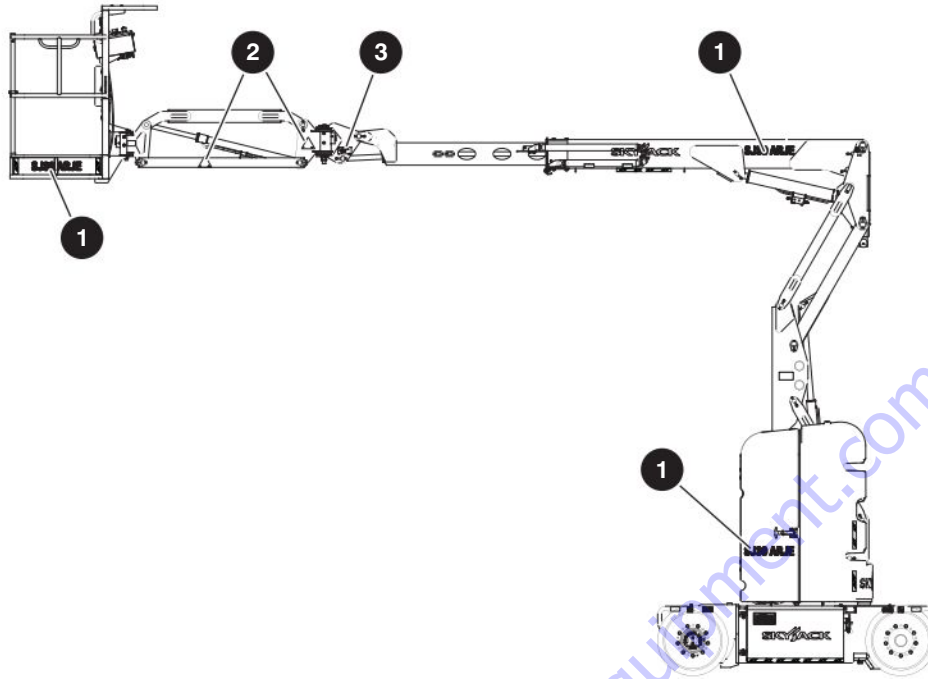

Description

Label Pictorial

1 Model number*

Product Identifier

**Model number will vary, may not be as shown.*

SJ30 AJE

SJ30 ARJE

2 Body crushing hazard

Warning - Body crushing hazard



3 Crushing hazard

Warning - Crushing hazard



4 Warning - Do not alter

Do not alter or disable limit switches or other safety devices.



Motor/Hydraulic side (continued)

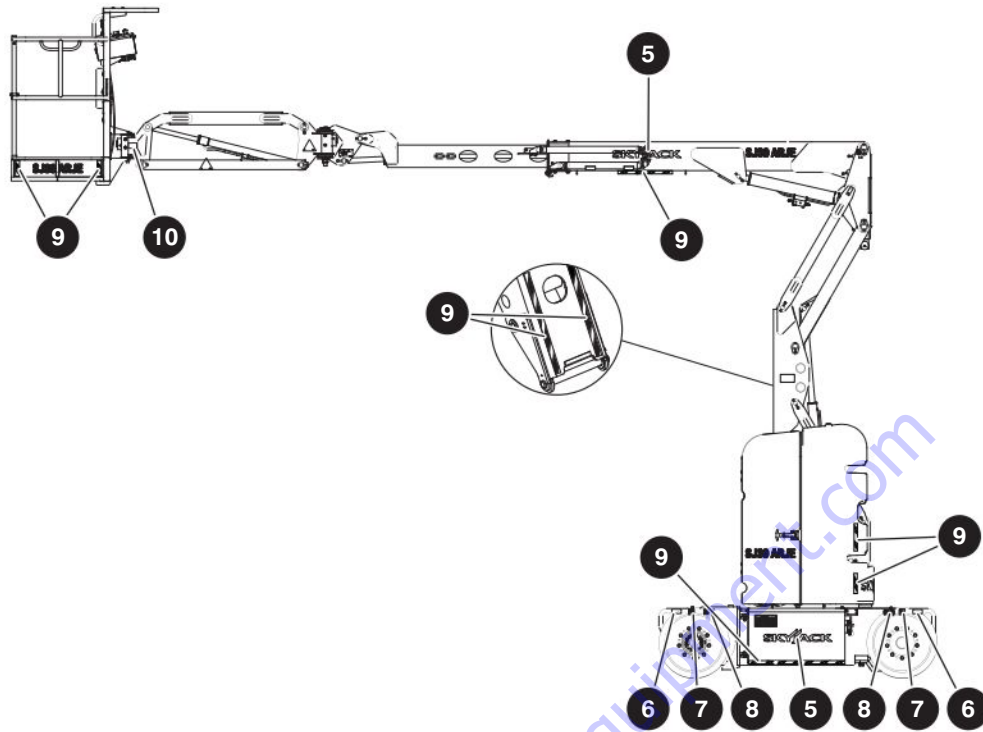

Description

Label Pictorial

- 5 Skyjack logo**
Skyjack



- 6 Lift and tie down points**
Only use these points for lifting or tying down.



- 7 Wheel load***
Indicates rated wheel load.
**Wheel load will vary over different MEWPs.*

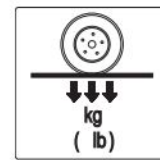

- 8 Wheel specifications**
Refer to manual for wheel type, offset, pressure and torque.



- 9 Caution tape stripe**



- 10 Tie down points**
Only use these points for tying down.

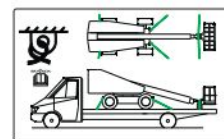

Motor/Hydraulic side (continued)

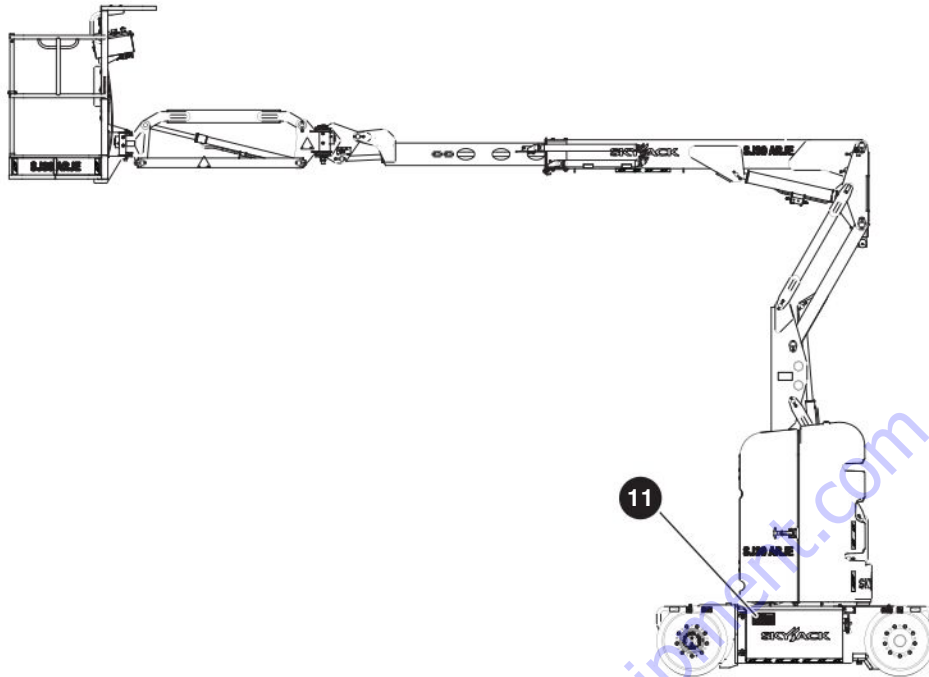

Description

Label Pictorial

11 Winching & towing procedure

Refer to operating manual.

1. Block or chock wheels to prevent MEWP from rolling.
2. On either the left or right side of the MEWP, disconnect and lock out main power connector.
3. Locate disengage cap on torque-hub at rear of base.
4. Using a 11mm (7/16") wrench, remove bolts.
5. Remove disengage cap and rotate to inward position. Insert disengage cap and fasten bolts.
6. Brake is now released.
7. Remove blocks/chocks from wheels and winch/tow to desired location.
8. Block or chock wheels to prevent MEWP from rolling.
9. Re-engage brake by performing the following steps:
 - a. Using a 11mm (7/16") wrench, remove bolts.
 - b. Remove disengage cap and rotate to outward position.
 - c. Reattach disengage cap and fasten bolts.
10. Brake is now re-engaged. On both the left and right sides of the MEWP, plug in main power connectors.



NOTE

Before operation, ensure all blocks are removed from wheels.

Motor/Hydraulic side (continued)

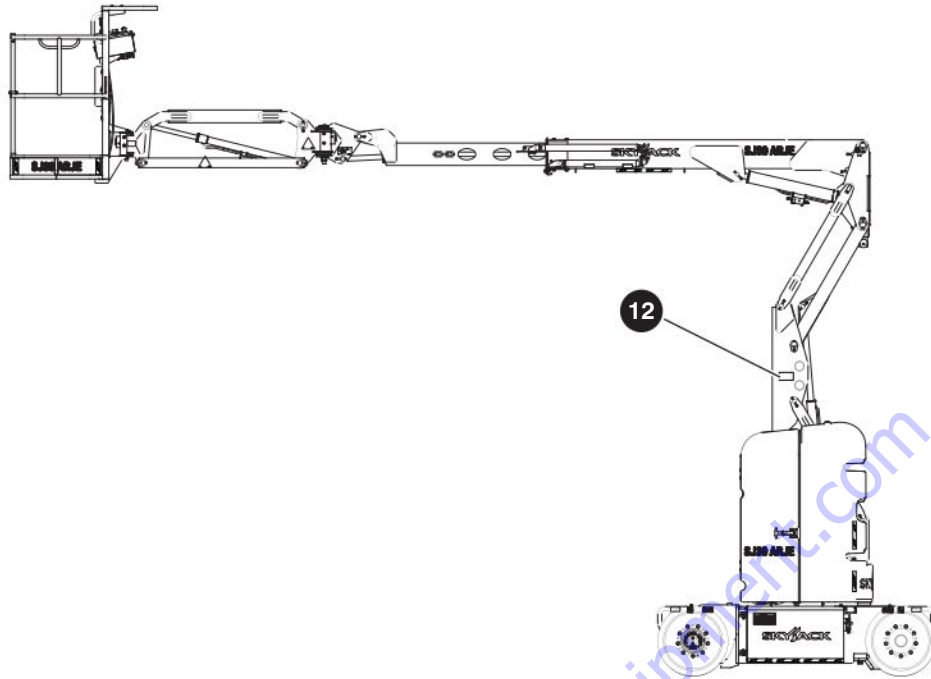

Description

Label Pictorial

12 Warning - Maintenance support

Do not enter the space beneath the work platform or extending structure during maintenance unless a means of structure support is in place. Refer to service manual for instructions regarding machine power isolation and structure support during maintenance.



Motor/Hydraulic compartment

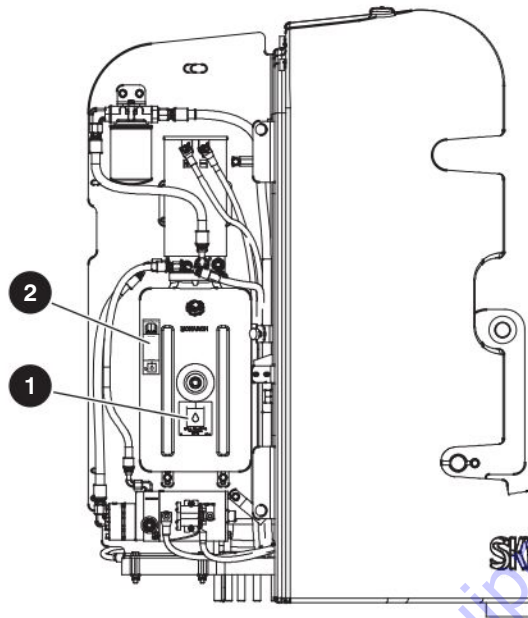

Description

Label Pictorial

1 Hydraulic oil

Replace hydraulic fluid with approved type (see service manual).

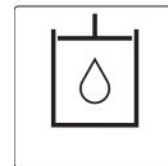

2 Hydraulic oil level

Indicates minimum/maximum oil level.



8.1-6 Rear side

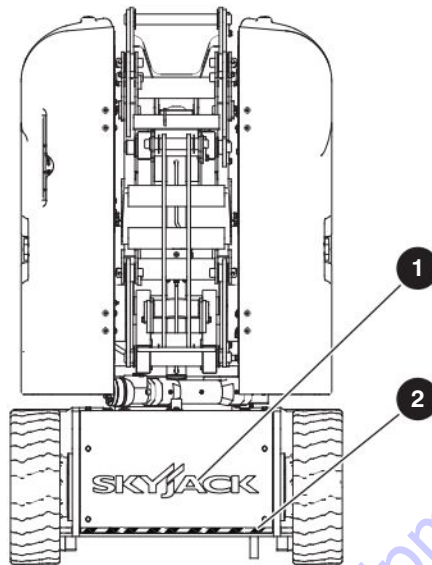

Description

Label Pictorial

- 1 Skyjack logo
Skyjack



- 2 Caution tape stripe



Section 9 – Unique Skyjack Features

Your Skyjack MEWP may be equipped with the following unique features:

SKYCODED™

At the heart of every Skyjack machine, proven and simplistic control systems using Skyjack's colour coded and numbered wiring system make our machines the easiest to troubleshoot and repair. – Black #14 is for the lift function on a 3219, and it is also the lift function on a 63AJ. Using an analog based control system allows the Skyjack AWP's to operate using a simplified system with fewer and less expensive components – less maintenance and lower costs.

SKYRISER™

A unique feature found on Skyjack's articulating boom lift. It ensures that the riser and main pivot point connecting the fly boom to the riser travel in a straight vertical line. Movement in a true vertical manner, without drifting forward or back, reduces the amount of repositioning the operator needs to do in order to stay close to a building façade.

EASYDRIVE™

A unique boom feature only utilized by Skyjack - the Boom Lift drive function operates in accordance with the general orientation of the turret's counterweight over the chassis (i.e. joystick forward = counterweight facing forward). This provides intuitive operation by allowing the unit to move in the general direction of the joystick's movement.

ACCESSORYZERS™

Having equipment with features and functionality that allow you and your customers to do more is a vital part of the utilization equation. Skyjack offers a range of accessory products to further expand a given product's adaptability and your power to offer a truly flexible rental choice.



WARNING

Cancer and Reproductive Harm-
<https://www.p65warnings.ca.gov/>.

To order go to DiscountEquipment.com

TO PURCHASE THIS PRODUCT PLEASE CONTACT US



**Equipment Financing and
Extended Warranties Available**



**Discount-Equipment.com is your online resource for
commercial and industrial quality parts and equipment sales.**

561-964-4949

visit us on line @ www.discount-equipment.com

Select an option below to find your Equipment

Search by Manufacturer

Search by Product Type

Request a Quote

We sell worldwide for the brands: Genie, Terex, JLG, MultiQuip, Mikasa, Essick, Whiteman, Mayco, Toro Stone, Diamond Products, Generac Magnum, Airman, Haulotte, Barreto, Power Blanket, Nifty Lift, Atlas Copco, Chicago Pneumatic, Allmand, Miller Curber, Skyjack, Lull, Skytrak, Tsurumi, Husquvarna Target, Stow, Wacker, Sakai, Mi-T-M, Sullair, Basic, Dynapac, MBW, Weber, Bartell, Bennar Newman, Haulotte, Ditch Runner, Menegotti, Morrison, Contec, Buddy, Crown, Edco, Wyco, Bomag, Laymor, EZ Trench, Bil-Jax, F.S. Curtis, Gehl Pavers, Heli, Honda, ICS/PowerGrit, IHI, Partner, Imer, Clipper, MMD, Koshin, Rice, CH&E, General Equipment, Amida, Coleman, NAC, Gradall, Square Shooter, Kent, Stanley, Tamco, Toku, Hatz, Kohler, Robin, Wisconsin, Northrock, Oztec, Toker TK, Rol-Air, APT, Wylie, Ingersoll Rand / Doosan, Innovatech, Con X, Ammann, Mecalac, Makinex, Smith Surface Prep, Small Line, Wanco, Yanmar



www.Discount-Equipment.com

To order go to Discount-Equipment.com

