



www.Discount-Equipment.com

SKYJACK[™]

OPERATING MANUAL

SJ519 TH

TELEHANDLER

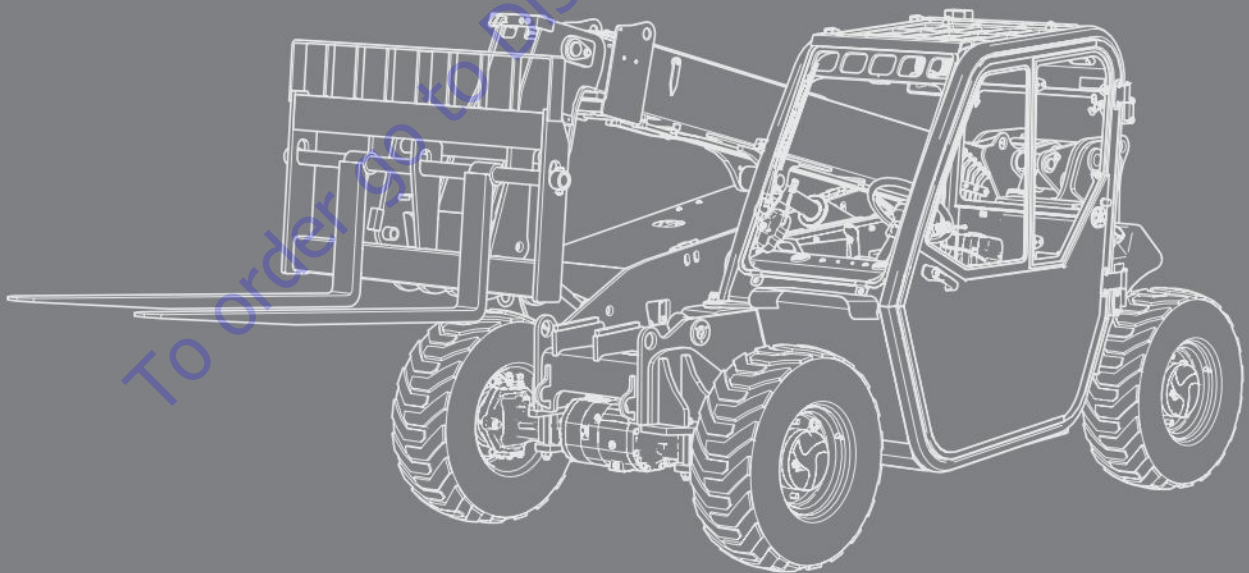

216939ADA

July 2019

ANSI/CSA

TO PURCHASE THIS PRODUCT PLEASE CONTACT US



**Equipment Financing and
Extended Warranties Available**



**Discount-Equipment.com is your online resource for
commercial and industrial quality parts and equipment sales.**

561-964-4949

visit us on line @ www.discount-equipment.com

Select an option below to find your Equipment

Search by Manufacturer

Search by Product Type

Request a Quote

We sell worldwide for the brands: Genie, Terex, JLG, MultiQuip, Mikasa, Essick, Whiteman, Mayco, Toro Stone, Diamond Products, Generac Magnum, Airman, Haulotte, Barreto, Power Blanket, Nifty Lift, Atlas Copco, Chicago Pneumatic, Allmand, Miller Curber, Skyjack, Lull, Skytrak, Tsurumi, Husquvarna Target, Stow, Wacker, Sakai, Mi-T-M, Sullair, Basic, Dynapac, MBW, Weber, Bartell, Bennar Newman, Haulotte, Ditch Runner, Menegotti, Morrison, Contec, Buddy, Crown, Edco, Wyco, Bomag, Laymor, EZ Trench, Bil-Jax, F.S. Curtis, Gehl Pavers, Heli, Honda, ICS/PowerGrit, IHI, Partner, Imer, Clipper, MMD, Koshin, Rice, CH&E, General Equipment, Amida, Coleman, NAC, Gradall, Square Shooter, Kent, Stanley, Tamco, Toku, Hatz, Kohler, Robin, Wisconsin, Northrock, Oztec, Toker TK, Rol-Air, APT, Wylie, Ingersoll Rand / Doosan, Innovatech, Con X, Ammann, Mecalac, Makinex, Smith Surface Prep, Small Line, Wanco, Yanmar

This manual is based on Serial Number:

SJ519 TH: 875 000 00 & Above

To order go to Discount-Equipment.com

Original instructions in English.

THIS SAFETY ALERT SYMBOL MEANS ATTENTION!



BE ALERT! YOUR SAFETY IS INVOLVED.

The Safety Alert Symbol identifies important safety messages on telehandlers, safety signs in manuals or elsewhere. When you see this symbol, be alert to the possibility of personal injury or death. Follow the instructions in the safety message.

DANGER

DANGER indicates an imminently hazardous situation which, if not avoided, will result in death or serious injury.

WARNING

WARNING indicates a potentially hazardous situation which, if not avoided, could result in death or serious injury.

CAUTION

CAUTION indicates a potentially hazardous situation which, if not avoided, may result in minor or moderate injury. It may also be used to alert against unsafe practices.

IMPORTANT

IMPORTANT indicates a procedure essential for safe operation and which, if not followed, may result in a malfunction or damage to the telehandler.

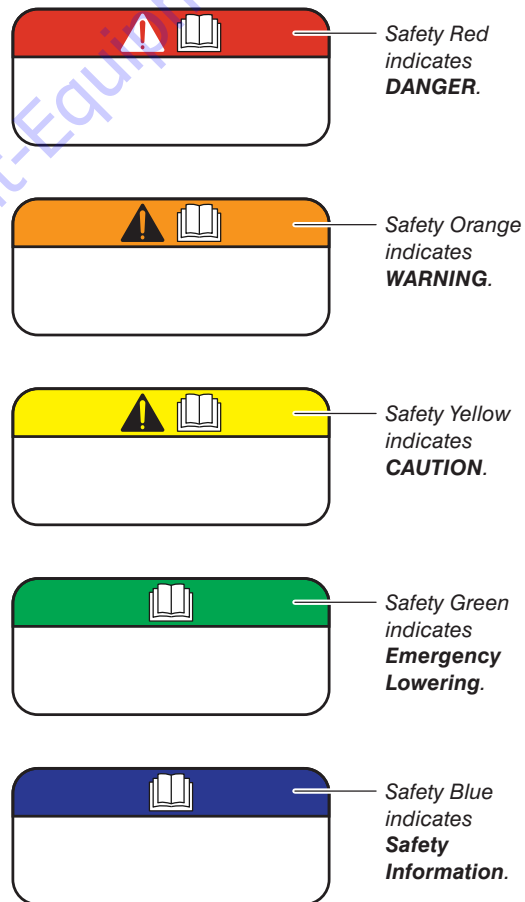

Figure 01 Label Legend

Table of Contents

Section 1 – About Your Telehandler	9
1.1 Read and Heed	9
1.1-1 <i>Telehandler Definition</i>	9
1.1-2 <i>Purpose of Equipment</i>	9
1.1-3 <i>Use of Equipment</i>	9
1.1-4 <i>Manual</i>	9
1.1-5 <i>Operator</i>	9
1.1-6 <i>Service Policy and Warranty</i>	9
1.1-7 <i>Ownership of Machine</i>	9
1.1-8 <i>Optional Accessories</i>	9
1.1-9 <i>Scope of this Manual</i>	10
1.2 Symbols & Nomenclature	11
1.3 Forklift Hand Signals	11
1.4 Major Assemblies	12
1.5 Serial Number Nameplate	12
1.6 Operator’s Responsibility for Maintenance	13
1.6-1 <i>Maintenance and Inspection Schedule</i>	13
1.6-2 <i>Owner’s Inspections</i>	13
Section 2 – Operator Safety	15
2.1 Electrocutation Hazard	15
2.2 Safety Precautions	16
2.3 Cab Access	20
2.4 Jobsite Inspection	20
Section 3 – Familiarization	21
3.1 Component Identification	22
3.2 Manual Storage Box	23
3.3 Control Functions	23
3.3-1 <i>Operator’s Cab Controls</i>	23
3.3-2 <i>Multi-functional Joystick</i>	24
3.3-3 <i>Operator’s Cab Dash Controls</i>	25
3.4 Safety Features and Devices	27
3.4-1 <i>Reverse Alarm</i>	27
3.4-2 <i>Parking Brake</i>	27
3.4-3 <i>Operator’s Cab</i>	27
3.4-4 <i>Operator’s Seat</i>	27
3.4-5 <i>Frame Level</i>	28

3.5	Optional Equipment	28
3.5-1	Positive Air Shutoff Switch (If Equipped)	28
3.5-2	Flashing Beacon (If Equipped)	28
3.5-3	Road Lights, Boom Lights & Work Lights (If Equipped)	28
3.5-4	Fire Extinguisher (If Equipped)	28
3.5-5	Back-up Sensor with Display Buzzer (If Equipped)	29
3.5-6	Back-up Sensor/Camera with Monitor (If Equipped)	29
3.5-7	Tilt Steering Option (If Equipped)	29
3.6	Optional Attachments	30
3.6-1	Side Tilt Carriage	30
3.6-2	Side Shift Carriage	30
3.6-3	Block Forks	31
3.6-4	Skid Steer Adapter	31
3.6-5	Truss Boom	32
3.6-6	Loader Bucket	32
Section 4 – Pre-operation		35
4.1	Operator’s Responsibility	35
4.2	Visual & Daily Maintenance Inspections	36
4.2-1	Labels	36
4.2-2	Electrical	36
4.2-3	Hydraulic	36
4.2-4	Cylinders	36
4.2-5	Mirrors	37
4.2-6	Frame	37
4.2-7	Engine Compartment	40
4.2-8	Boom	41
4.2-9	Lifting Attachment	41
4.2-10	Grease Points	41
4.2-11	Operator’s Cab	42
4.2-12	Operator’s Cab Controls	43
4.3	Function Tests	44
4.3-1	Test Starter Operation	44
4.3-2	Test Horn	45
4.3-3	Test Lights (If Equipped)	45
4.3-4	Test Boom Functions	46
4.3-5	Test Attachment Functions	46
4.3-6	Test Accelerator Pedal	47
4.3-7	Test Reverse Alarm, Driving & Service Brake	47
4.3-8	Test Parking Brake	48
4.3-9	Test Steering	48
4.3-10	Test Back-up Sensor with Display Buzzer (If Equipped)	50
4.3-11	Test Back-up Sensor/Camera with Monitor (If Equipped)	50

4.4	Operator's Checklist	51
Section 5 – Operation		53
5.1	Starting the Engine	54
5.2	Driving the Telehandler	54
	5.2-1 <i>Driving on Level Terrain</i>	54
	5.2-2 <i>Driving on Slopes</i>	54
5.3	Steering the Telehandler	55
	5.3-1 Four-wheel Steering	55
	5.3-2 Front Steering (Two-Wheel)	55
	5.3-3 Crab Steering	55
	5.3-4 <i>Adjusting the Tilt Steering Wheel (If Equipped)</i>	55
5.4	Operating the Boom	56
	5.4-1 <i>Raising or Lowering Boom</i>	56
	5.4-2 <i>Extending or Retracting Boom</i>	56
5.5	Tilting the Attachment	56
5.6	Handling Loads	56
5.7	Handling Loads at Ground Level	57
	5.7-1 <i>Picking up a Load</i>	57
	5.7-2 <i>Transporting a Load</i>	57
	5.7-3 <i>Placing a Load</i>	57
5.8	Handling Loads at Variable Heights	58
	5.8-1 <i>Picking up a Load</i>	58
	5.8-2 <i>Placing a Load</i>	58
5.9	Parking and Shutting Down the Telehandler	58
5.10	DEUTZ Engine Data Display Module	59
	5.10-1 <i>Function Buttons</i>	59
	5.10-2 <i>Contrast & Illumination Settings</i>	59
	5.10-3 <i>Engine Main Display</i>	59
	5.10-4 <i>Quad Display</i>	60
	5.10-5 <i>Graphic Display</i>	60
	5.10-6 <i>Error Messages</i>	60
	5.10-7 <i>Display Configuration</i>	61
5.11	Use of the Capacity Charts	62
	5.11-1 <i>Maximum Load Capacity</i>	62
	5.11-2 <i>Examples on Reading the Capacity Chart</i>	63
5.12	Attachment Installation and Adjustment	64
	5.12-1 <i>Installing Attachments Using the Quick Attach Feature</i>	64
	5.12-2 <i>Removing Attachments Using the Quick Attach Feature</i>	64
	5.12-3 <i>Installing Attachments Using the Hydraulic Quick Attach Feature (If Equipped)</i>	65
	5.12-4 <i>Removing Attachments Using the Hydraulic Quick Attach Feature (If Equipped)</i>	65
	5.12-5 <i>Adjusting Forks</i>	66
	5.12-6 <i>Changing Forks</i>	66

5.13	Slinging Loads	67
5.14	Third-Party Attachments	67
Section 6 – Procedures		69
6.1	Refueling Procedure	69
	6.1-1 Diesel Fuel	69
6.2	Lifting SJ519 TH	70
6.3	Loading, Tie-downs and Transporting	71
6.4	Towing the Telehandler	72
6.5	Using the Telehandler as a Tow Vehicle	73
	6.5-1 Rear Hitch	73
Section 7 – Specifications		75
7.1	Standard and Optional Equipment	76
7.2	Specifications and Features	77
7.3	Tire/Wheel Specifications	78
7.4	Recommended Fluids/Lubrications	79
Section 8 – Labels		81
8.1	Model SJ519 TH	82
Section 9 – Unique Skyjack Features		97

To order go to Discount-Equipment.com

Section 1 – About Your Telehandler

1.1 Read and Heed

Skyjack is continuously improving and expanding product features on its equipment, therefore, specifications and dimensions are subject to change without notice.

1.1-1 Telehandler Definition

A material handler designed primarily as a fork truck with a pivoting telescopic boom which enables it to pick and place loads at distances as well as various lift heights.

1.1-2 Purpose of Equipment

The Skyjack telehandlers are designed to lift, handle and transport agricultural or industrial products by means of specific attachments.

1.1-3 Use of Equipment

The telehandler is a highly maneuverable variable reach rough terrain forklift (RTFL). Lifting, handling and driving must be on a flat, level, compacted surface. It can be driven over uneven terrain only when the boom is fully lowered.

1.1-4 Manual

The operating manual is considered a fundamental part of the telehandler. It is a very important way to communicate necessary safety information to users and operators. A complete and legible copy of this manual must be kept in the provided weather-resistant storage compartment on the telehandler at all times.

1.1-5 Operator

The operator must read and completely understand both this operating manual and the hazard identification label located in the cab of the telehandler and all other warnings in this manual and on the telehandler. Compare the labels on the telehandler with the labels found within this manual. If any labels are damaged or missing, replace them immediately.

Only trained and authorized personnel shall be permitted to operate the telehandler.

The operator must be familiar with employer's work rules and related government regulations and be able to demonstrate the ability to understand and operate this make and model of telehandler in the presence of a qualified person.

1.1-6 Service Policy and Warranty

Skyjack warrants each new product to be free of defective parts and workmanship for the first 2 years or 3000 hours, whichever occurs first. Any defective part will be replaced or repaired by your local Skyjack dealer at no charge for parts or labor. In addition, all products have a 5 year structural warranty. Contact the Skyjack Service Department for warranty statement extensions or exclusions.

1.1-7 Ownership of Machine

Notify Skyjack of machine ownership. If you have sold or transferred any machine, promptly notify Skyjack of new owner's contact information.

1.1-8 Optional Accessories

The Skyjack telehandler is designed to accept a variety of optional accessories. These are listed under [Section 3.6](#). Operating instructions for these options (if equipped) are located in [Section 5 – Operation](#) of this manual.

For non-standard components or systems, contact the Skyjack Service Department at:

☎: 800 275-9522

☎: 630 262-0006











Include the model and serial number for each applicable telehandler.

1.1-9 Scope of this Manual















1. This manual applies to the ANSI/ITSDF and CSA versions of the SJ519 TH telehandlers.
 - Equipment identified with “ANSI” meets the ANSI/ITSDF B56.6-2016 standard.
 - Equipment identified with “CSA” meets the CSA B335-15 standard.
2. **CSA (Canada):** Operators are required to conform to national, territorial/provincial and local health and safety regulations applicable to the operation of this telehandler.
3. **ANSI/ITSDF (United States):** Operators are required by the current ANSI standards to conform to national, territorial/provincial and local health and safety regulations applicable to the operation of this telehandler.

To order go to Discount-Equipment.com

1.2 Symbols & Nomenclature

Symbol	Description	Symbol	Description
	Diesel Fuel Fuel Tank		Engine Oil Level
	Engine Air Intake		Hydraulic Oil
	Engine Coolant		Hydraulic Oil Level
	Engine Coolant Level		Positive Air Shutoff (Engine high idle)
	Drain Water/Fuel Separator		Engine Oil

1.3 Forklift Hand Signals

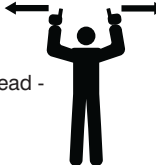
1. Stop 	2. Emergency Stop 	3. Retract boom 	4. Extend boom 
5. Raise boom/mast 	6. Lower boom/mast 	7. Hoist load 	8. Lower load 
9. Tilt forks/attachment up 	10. Tilt forks/attachment down 	11. Travel backwards 	12. Travel forwards 
13. Swing attachment left 	14. Swing attachment right 	15. Fork Spread - Closed 	16. Fork Spread - Open 

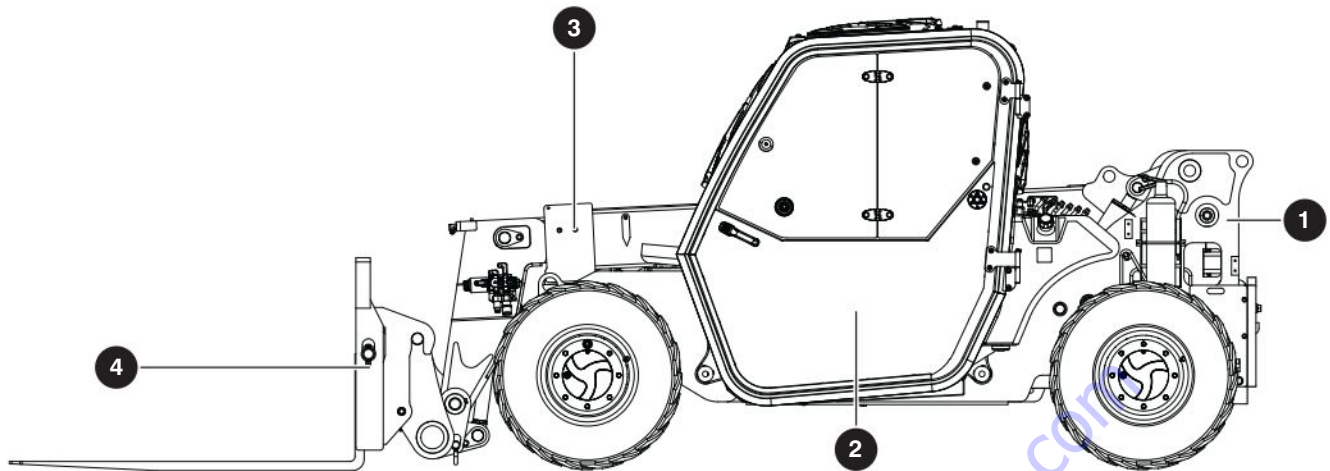

1.4 Major Assemblies

The telehandler consists of four major assemblies: the frame, boom assembly, attachment and cab.

- 1 **Frame:** The frame is a one-piece weldment that supports the boom assembly. The parking brake is integral with the axle and is located in the front axle.
- 2 **Cab:** The cab is the safety structure enclosing the operator. It also furnishes the controls of the telehandler.
- 3 **Boom Assembly:** The boom is mounted on the frame and consists of telescoping boom sections. SJ519 TH telehandlers have a main boom and a fly boom. The telehandler is equipped with a carriage tilt cylinder, which is mounted to the inside of the jib. The quick attachment is mounted to the jib and is supported by the tilt cylinder.
- 4 **Attachment:** The attachment is a material-handling device attached to the boom. The standard attachment is a fork-carriage attachment. Refer to [Section 3.6](#) for various optional attachments.

1.5 Serial Number Nameplate

The **serial number nameplate** 5, located at the front left side of telehandler lists the following:

- Model number
- Serial number
- Maximum capacity
- Maximum lift height
- Maximum machine weight without attachment
- Original supplied attachments
- Year of manufacture
- Voltage

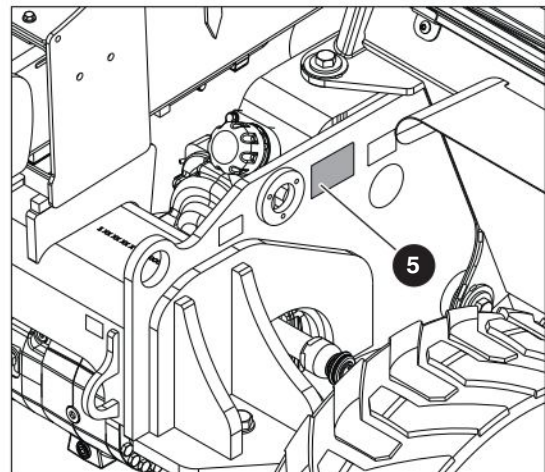

Figure 02 Serial Number Nameplate location

1.6 Operator's Responsibility for Maintenance

WARNING

Maintenance must be performed by trained and competent personnel who are familiar with mechanical procedures.

Death or serious injury could result from the use of a telehandler that is not properly maintained or kept in good working condition.

The operator must be sure that the telehandler has been properly maintained and inspected before using it.

The operator must perform all the daily inspections and function tests found on the Operator's Checklist (see [Section 4.4](#)), even if the operator is not directly responsible for the maintenance of this telehandler.

1.6-1 Maintenance and Inspection Schedule

Refer to Service manual for quarterly (or 250 hours) and annual inspection details.

The actual operating environment of the telehandler may affect the maintenance schedule.

WARNING

Use original or manufacturer-approved parts and components for the telehandler.

NOTE

Refer to Skyjack's website www.skyjack.com for the latest service bulletins prior to performing frequent/periodic or annual inspections.

1.6-2 Owner's Inspections

It is the responsibility of the owner and/or operator to arrange daily, quarterly (or 250 hours) and annual inspections of the telehandler. Refer to the Service manual for recommended maintenance and inspection areas and intervals.

Section 2 – Operator Safety

WARNING

Failure to comply with your required responsibilities in the use and operation of the telehandler could result in death or serious injury!

A study conducted by St. Paul Travelers showed that most accidents are caused by the failure of the operator to follow simple and fundamental safety rules and precautions.

You, as a careful operator, are the best insurance against an accident. Therefore, proper usage of this telehandler is mandatory. The following pages of this manual should be read and understood completely before operating the telehandler.

Common sense dictates the use of protective clothing when working on or near machinery. Use appropriate safety devices to protect your eyes, ears, hands, feet and body.

Any modifications from the original design are strictly forbidden without written permission from Skyjack.

2.1 Electrocutation Hazard

This telehandler is not electrically insulated. Use extreme caution around high-voltage overhead power lines and parts. Maintain a Minimum Safe Approach Distance (MSAD) of 10 ft from sources of power (*Figure 03*). If the work requires to be closer than 10 ft, stop and consult a qualified person with respect to electrical transmission and distribution to have appropriate measures taken.

Adhere to all federal/national, state/provincial, or local safety regulations for your own protection.

No part of telehandler or payload must be brought closer to any energized overhead electrical conductor with nominal phase voltage rating as specified below.

Minimum Safe Approach Distance	
Voltage Range	Minimum Safe Approach Distance
≤ 50 KVA	3 m (10 ft)
> 50 KVA	Stop and consult a qualified person with respect to electrical transmission and distribution to have appropriate measures taken
FAILURE TO AVOID THIS HAZARD WILL RESULT IN DEATH OR SERIOUS INJURY	

Figure 03 Minimum Safe Approach Distance

DANGER

Never approach any power line with any part of telehandler. Use extreme caution; serious injury or death can result with contact from any power line.

IMPORTANT

Always assume electrical power sources and overhead lines are energized.



MAINTAIN a Minimum Safe Approach Distance from sources of high-voltage power.



DO NOT operate telehandler during lightning or storms. Take into account the effects of weather (e.g., wind, rain and snow) on the safe operation of the rough terrain forklift truck.

WARNING

Do not use the telehandler as a ground for welding.

2.2 Safety Precautions

Know and understand the safety precautions before going on to next section.

WARNING

DO NOT operate this telehandler without proper authorization and training. Failure to avoid this hazard could result in death or serious injury.

WARNING

Failure to heed the following safety precautions could result in tip over, falling, crushing, or other hazards leading to death or serious injury.

MAKE SURE all DANGER, WARNING, CAUTION and INSTRUCTIONAL DECALS are in place and can be read. Clean or replace decals as required.

KNOW all national, state/provincial and local rules which apply to your telehandler and jobsite.

WEAR all the protective clothing and personal safety devices issued to you or called for by job conditions.



DO NOT wear loose clothing, dangling neckties, scarves, rings, wristwatches or other jewelry while operating this telehandler.



DO NOT use this telehandler under influence of alcohol or drugs, or if operator's performance is impaired by a medical condition, the influence of prescription or over the counter drugs, or fatigue.



DO NOT climb on this vehicle for any reason.



DO NOT stand on forks. Failure to heed could result in death or serious injury.



DO NOT use carriage or any other portion of the boom for slinging loads unless on a manufacturer's approved attachment point that is supplied with the machine.



DO NOT elevate the boom in windy or gusty conditions.



DO NOT drive with boom elevated.



DO NOT operate on surfaces not capable of holding the weight of the telehandler; including the rated load (e.g., covers, drains, and trenches).



DO NOT maneuver a load while moving. This greatly increases the chance of spills and injury.



DO NOT enter the danger area under or around the boom when forks are off the ground or while engine is running.



DO NOT lower the boom unless the area below is clear of personnel and obstruction.



DO NOT elevate the boom while the telehandler is on a truck, forklift or other device or vehicle.



ENSURE that there are no personnel or obstructions in the path of travel, including blind spots.

BE AWARE of blind spots when operating the telehandler.



ALWAYS keep head, arms, hands, legs and all other body parts inside the operator's cab. Never put any part of the body between any moving component and another obstacle including but not limited to: the load handling structure; the reach mechanism; the rough terrain forklift truck attachment



AVOID jerks and sudden stops.



AVOID entanglement with ropes, cords or hoses.



BE AWARE of all obstructions while traveling.



USE CAUTION when boom is fully extended. The further out the boom is extended, the less load telehandler can support.



USE CAUTION when placing loads at high elevations and on downhill slopes.



IF OPERATION IN AREAS WITH HOLES OR DROP-OFFS IS ABSOLUTELY NECESSARY, ensure that all four wheels have contact with firm surface. After boom elevation, the drive function must not be activated.



TRAVEL SLOWLY over rough terrain.



KNOW the weight of the load you are transporting. Never lift more than the lifting capacity at any given extension or elevation of the boom as listed on the capacity charts.



CHECK for cracks and signs of stress.



BE AWARE of the telehandler’s travel envelope, especially when turning. Keep sufficient clearance at all times between the telehandler and any obstacles or people.

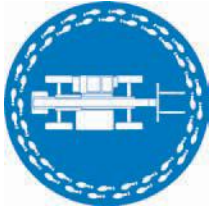

WALK AROUND the telehandler before operation and check for any visible signs of damage or malfunction.



ALWAYS maintain three points of contact when entering vehicle. Use provided hand-holds and steps only.

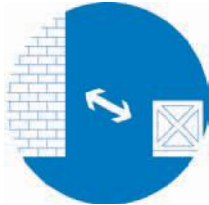

CHECK for clearance before traveling between obstacles.



ALWAYS wear your seat belt when operating this vehicle.



DRIVE DOWNHILL UNLOADED. Without a load, the back end is the heaviest part of the telehandler. Driving downhill decreases potential for tip-over.



DRIVE UPHILL LOADED When holding a load, driving uphill decreases potential for load to slip out.



WHEN TRANSPORTING LOADS fully retract the boom, keep the load low to the ground and forks tilted back slightly. This is the most stable position possible for the vehicle.

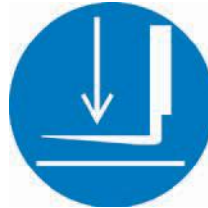

KEEP forks close to the ground when in motion to increase telehandler stability and decrease potential for injury to others. When fully stopped, lower forks completely to the ground.



TILT forks backward slightly when traveling to decrease potential of load slipping off.

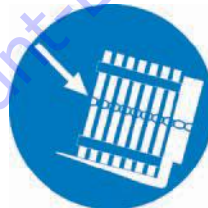

SECURE loose loads with chains or straps to decrease potential of spills or injury to others.



TETHER LOADS that may swing, keeping them close to the ground. Provide ample clearance for personnel to guide the load safely.



SLINGING LOADS is acceptable only when the load is appropriately attached to the lifting hook, a jib boom or the heel of a tilted fork, and the precautions outlined in [Section 5.13](#) are followed.



KEEP OTHERS AWAY at all times during operation.



CHECK lights for proper function before operating.



ENSURE ALL tires are in good condition and lug nuts are properly tightened.

DO NOT alter or disable safety devices.

DO NOT burn or drill holes in forks. Modifying any part of telehandler or attachment affects its capacity and/or stability.

DO NOT try to start the telehandler by pushing or towing. Such operation may cause severe damage to the transmission (refer to *Section 5 – Operation*).

IF DRIVING ON ROADS OPEN TO PUBLIC TRAFFIC respect the local regulations.

THE OPERATOR'S CAB provides a falling object protection structure (FOPS) and a rollover protection structure (ROPS). Do not make any modification to this structure. If damaged, the cab cannot be repaired. It must be replaced.

STUNT driving and horseplay are prohibited.

ALWAYS USE FRONT steering when traveling at high speeds; i.e. on highways and public roads.

DO NOT change steering mode while the telehandler is traveling. Change the steering mode only when telehandler is stopped.

ALWAYS look in the direction of travel. Reduce speed and be especially careful when traveling in reverse and/or turning. Bring the telehandler to a complete stop before changing the direction of travel.

STAY CLEAR of pinch points and rotating parts on the material handler. Getting caught in a pinch point or a moving part can cause serious injury or death.

Before performing any maintenance on telehandler, follow the shutdown procedure on *Section 5.9*.

DO NOT position the telehandler against another object to steady the load.

DO NOT operate on slippery surfaces not capable of providing adequate traction to stop, drive or steer the telehandler.

SHUT DOWN by positioning the telehandler in a safe location. Lower boom to ground, apply the park brake, move all controls to neutral and allow engine to idle for 3 to 5 minutes. Stop engine and remove ignition key to prevent unauthorized use.

WARNING

Always move all controls to neutral, press the park brake switch (P) to on position. **and shut off engine before exiting the operator's cab.**

2.3 Cab Access

WARNING

Entering and exiting the telehandler should only be done using the three points of contact.

Use three points of contact to enter and exit the cab. Face the telehandler when entering or exiting the cab.

Three points of contact means that two hands and one foot or one hand and two feet are in contact with the telehandler or the ground at all times during entering and exiting.

WARNING

Operator should not use any telehandler that:

- does not appear to be working properly.
- has been damaged or appears to have worn or missing parts.
- has alterations or modifications not approved by the manufacturer.
- has safety devices which have been altered or disabled.
- has been tagged or locked out for non-use or repair.
- bears an unapproved attachment.

Failure to avoid these hazards could result in death or serious injury.

NOTE

Improper operation, faulty maintenance, or poor housekeeping may contribute to a condition of instability

2.4 Jobsite Inspection

Be sure to follow all local, provincial/territorial/state and national regulations related to operating variable reach rough terrain forklifts (RTFLs). Do not use the telehandler in hazardous locations.

Always monitor the workplace for changing conditions that could create potentially hazardous situations.

The storage and handling of liquid fuels and liquefied petroleum gas fuel used in RTFL shall be in accordance with NFPA 505, NFPA 30 and NFPA 58 as applicable. The user needs to determine the hazard classification of any particular atmosphere or location according to ANSI/NFPA 505. In addition, rough terrain forklift trucks operated in hazardous areas shall be approved and of the type required by ANSI/NFPA 505.

Perform a thorough job site inspection prior and during the operation of the telehandler to identify potential hazards in your work area.

It is the responsibility of the operator to perform a job site inspection and avoid the following hazardous situations:

- holes or drop-offs
- ditches or soft fills
- floor obstructions, bumps or debris
- overhead obstructions
- electrical cords, hoses and high voltage conductors
- hazardous locations
- inadequate surface support to withstand all load forces imposed by the telehandler
- wind and weather conditions
- the presence of unauthorized personnel
- other possible unsafe conditions

Section 3 – Familiarization

WARNING

Do not operate this telehandler without proper authorization and training. Failure to avoid this hazard could result in death or serious injury.

WARNING

It is the responsibility of the operator to read, completely understand and follow all instructions and warnings contained in this operating manual and on the telehandler.

To order go to Discount-Equipment.com

3.1 Component Identification

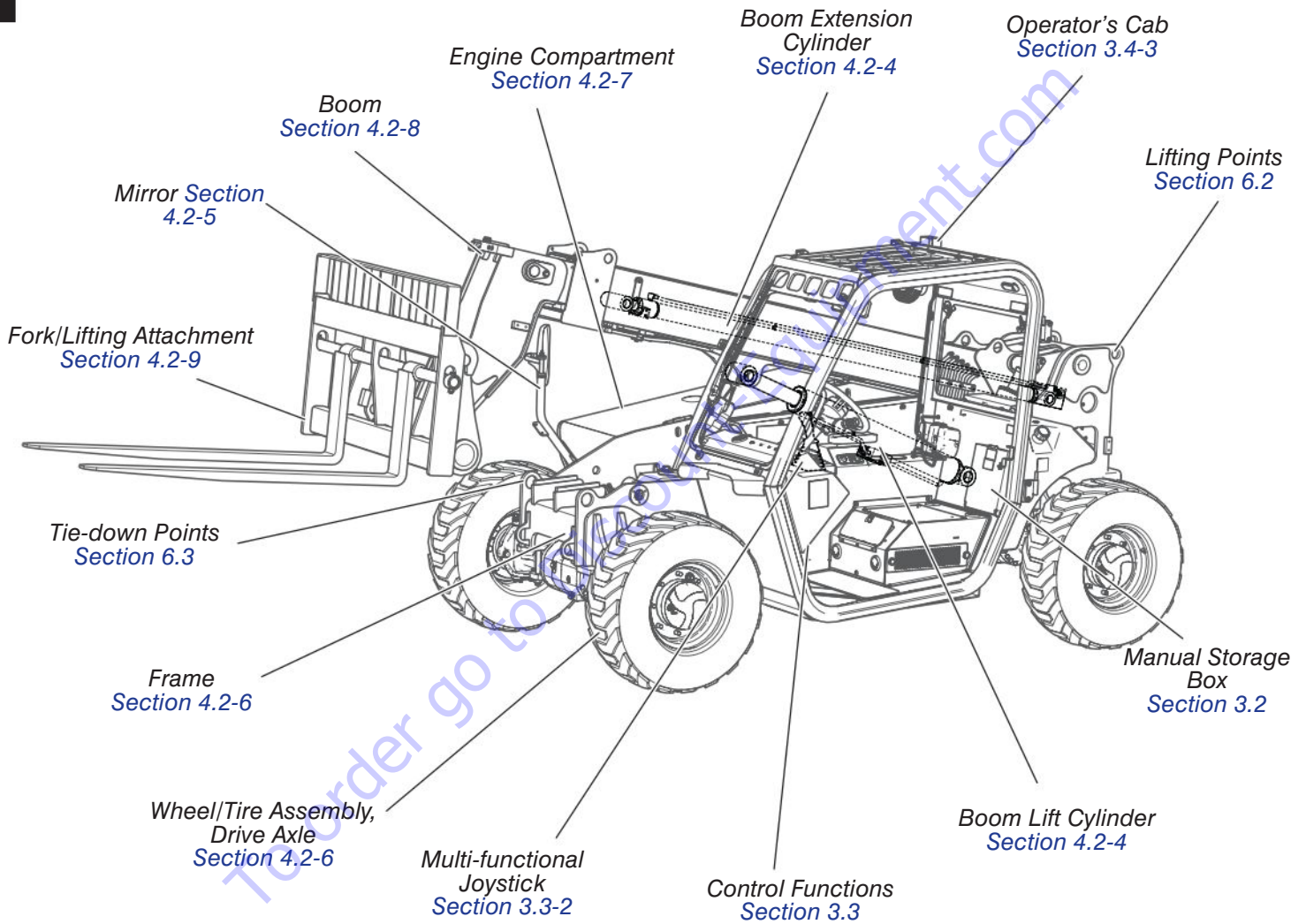

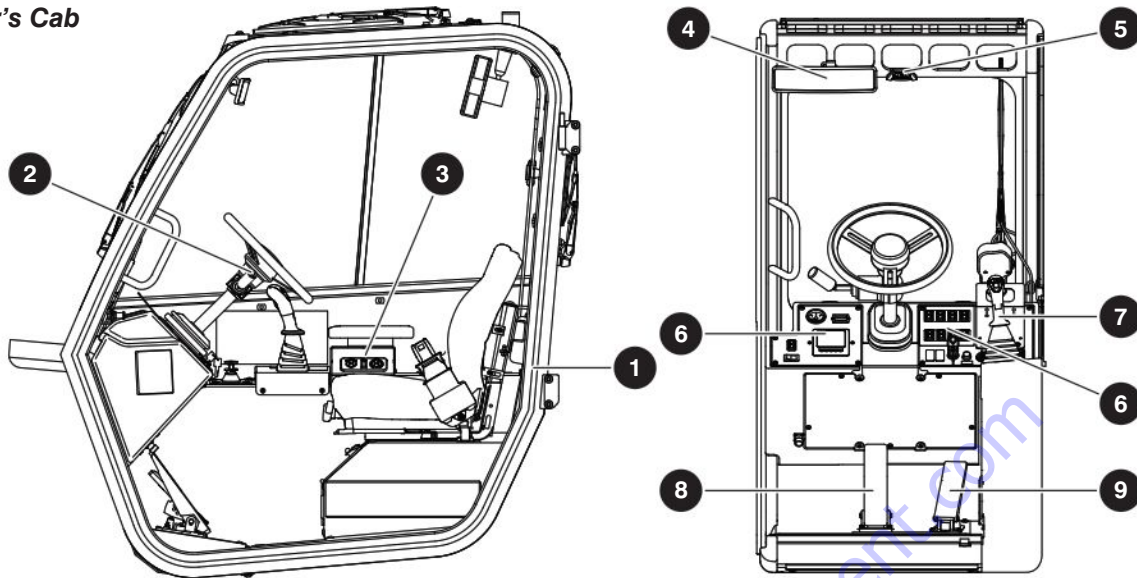
Operator's Cab**3.2 Manual Storage Box**

This weather-resistant box is mounted at the back of the operator's seat ①. It contains the operating manual and other important documentation. The operating manual for this make and model of telehandler must remain with the telehandler and should be stored in this box.

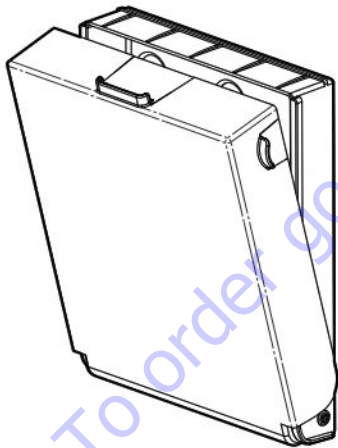

Figure 04 Manual Storage Box

3.3 Control Functions**3.3-1 Operator's Cab Controls**

- ② **Steering Wheel:** Turn the steering wheel to the left or right to steer the telehandler in the corresponding direction. Three steering modes are available (refer to [Section 5.3](#)).
- ③ **Cab Heater and Air Conditioner Controls (If Equipped):** A switch and two knobs to adjust the temperature inside the cab.
- ④ **Rear View Mirror:** Allows the operator to check the surrounding area behind telehandler.
- ⑤ **Level Indicator:** Located on the upper cross member of the overhead guard. When the ball is centred in the indicator, this indicates that telehandler frame is level.
- ⑥ **Front Dash:** Location of controls essential to the operation of the telehandler (refer to [Section 3.3-3](#) for details).
- ⑦ **Multi-functional Joystick:** A control allowing the operator to control boom and attachment operation (refer to [Section 3.3-2](#) for details).
- ⑧ **Service Brake Pedal:** The service brake is foot operated and is used to decrease speed or stop.
- ⑨ **Accelerator Pedal:** Press pedal to increase speed and release pedal to decrease speed.

Multi-functional Joystick

Auxiliary function buttons
and Carriage attachment
tilt enable buttons

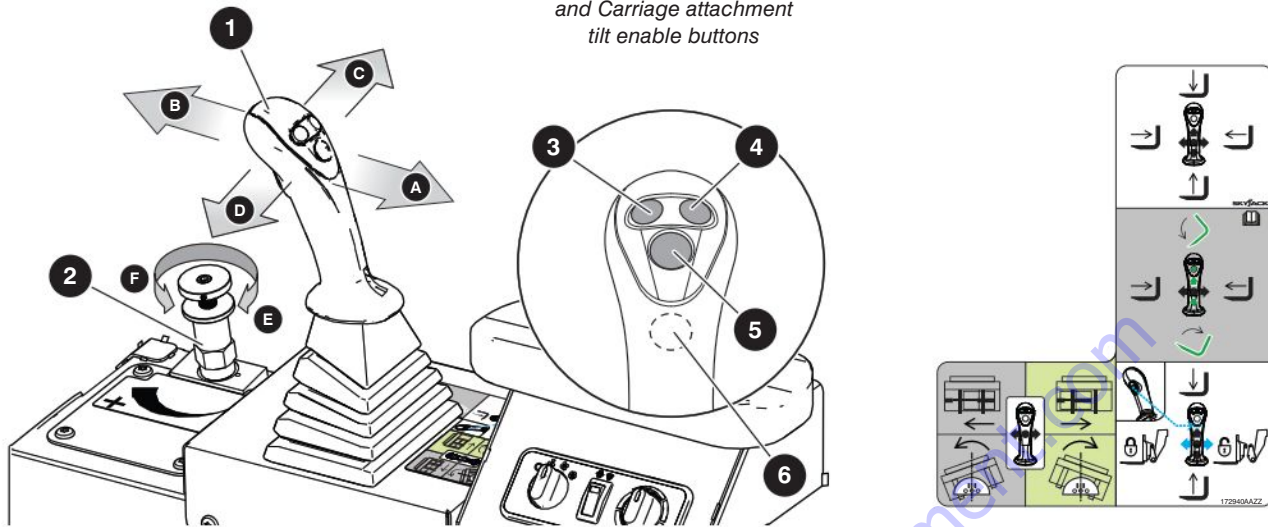

3.3-2 Multi-functional Joystick

This dual-axis joystick is a multi-functional control that allows boom operation (extend or retract and up or down), fork tilt, and auxiliary functions such as carriage side tilt or carriage swing. The joystick returns to neutral position when released. It includes the following additional controls:

1 Joystick

- Raise the boom **A** by moving joystick backward.
- Lower the boom **B** by moving the joystick forward.
- Extend the boom **C** by moving the joystick to the right.
- Retract the boom **D** by moving the joystick to the left.

2 Attachment Hydraulic Flow Control

- Increase the flow of hydraulic fluid **E** through the attachment by turning the Attachment Hydraulic Flow Control clockwise.
- Decrease the flow **F** by turning it counterclockwise.





3 Left Auxiliary Function Button

- Left auxiliary function is operated by pressing and holding the left button.

4 Right Auxiliary Function Button

- Not Used.

5 Carriage Attachment Tilt Enable Button

- Tilt attachment forward by pressing and holding carriage attachment tilt enable button  and moving joystick forward .
- Tilt attachment backwards by pressing and holding carriage attachment tilt enable button  and moving the joystick backward .

6 Trigger Auxiliary Function Button

- Lock the hydraulic quick attach by pressing the trigger auxiliary function button and moving the joystick to the left.
- Unlock the hydraulic quick attach by pressing the trigger auxiliary function button and moving the joystick to the right.



NOTE

The right joystick button is not functional on SJ519 TH telehandlers.



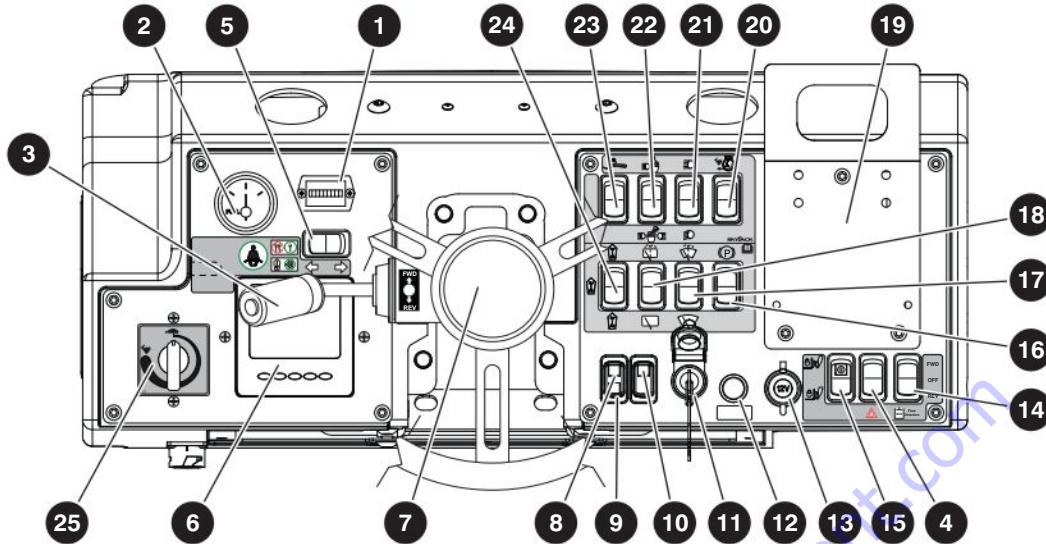

For operational controls of each attachment, see [Section 3.6](#).

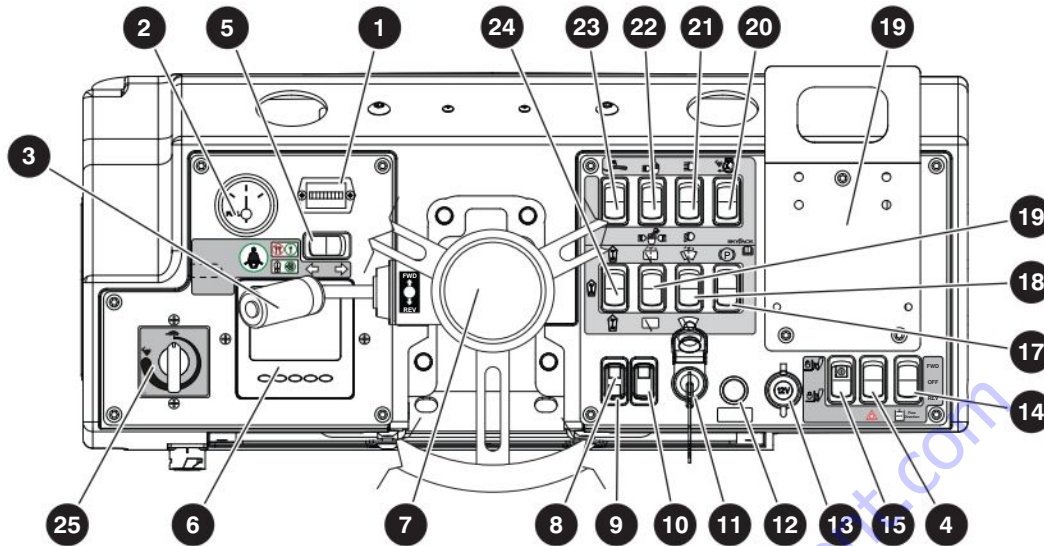

3.3-3 Operator's Cab Dash Controls

- ➊ **Hourmeter:** This gauge records accumulated operating time of the telehandler.
- ➋ **Fuel Gauge:** Indicates the amount of fuel in the fuel tank. Fill the tank with ultra low sulfur diesel fuel only when the indicator needle moves below the 1/4 tank mark.
- ➌ **Direction Control Lever:** This lever allows forward or reverse travel. The center position is neutral. To select forward travel, lift from lock position and move the direction control lever to the FWD position; for reverse travel move lever to REV.
- ➍ **Hazard Warning Light Switch (If Equipped):** The hazard warning light switch activates all four turn signals to indicate an emergency situation.
- ➎ **Left and Right Turn Signals Switch (If Equipped):** This rocker switch controls left and right turn signals located on both the front and rear of the telehandler.
- ➏ **Engine Data Display Module:** Allows the operator to select the required engine data such as engine RPM, engine temperature, voltage, and visualize it in the following formats:
 - Analogue display
 - Digital data
 - Graphics
 - Multi-data (a combination of the above)
 - Current alarm messages
 (Refer to [Section 5.10](#) for details).
- ➐ **Steering Wheel/Tilt (If Equipped):** Turn the steering wheel to the left or right to steer the telehandler in the corresponding direction. Three steering modes are available (refer to [Section 5.3](#)).
- ➑ **Glow Plug Indicator:** This light illuminates until glow plugs have completed their timed cycle. When the lamp goes out, the engine is ready to be started.
- ➒ **Hydraulic Oil Temperature Indicator:** This red light indicator illuminates when the hydraulic oil temperature is outside normal operating range.
- ➓ **Positive Air Shut-off Valve Indicator (If Equipped):** Illuminates red for a few seconds when testing the functionality of positive air shut-off valve.
- ➔ **Ignition Switch:** This is a three position, anti-restart switch.
 - When in OFF position, it turns the engine off and key can be removed.
 - When in ON position, it provides power to ignition and auxiliary circuits.
 - When in START position, it starts the engine; when released, key returns to ON position.
- ➕ **Horn Button:** When depressed, the horn button activates an audible warning.
- ➖ **12 Volt Power Port:** A convenient 12 Volt power port is located on the dashboard.
- ➗ **Attachment Hydraulic Flow Switch:** Turns hydraulic fluid flow to the attachment on and off.



- 15 Hydraulic Quick Attach Switch (If Equipped):** Opens and closes the hydraulic quick attach function (see [Section 5.12-3](#)).
- 16 Park Brake Switch/Indicator:** This switch controls the spring applied, hydraulically released parking brake. Apply the parking brake by pressing the switch at the end marked (P) when the engine is running. When the brake is on, the red warning light illuminates.
- 17 Front and Top Windshield Wiper/Washer Switch (If Equipped)** : This switch activates the wiper and the washer for the front and top windshields. Press top portion to activate washer/wiper. Press bottom portion to activate wiper.
- 18 Rear Windshield Wiper/Washer Switch (If Equipped):** This switch activates the wiper and the washer for the rear windshield. Press top portion to activate washer/wiper. Press bottom portion to activate wiper.
- 19 Capacity Charts:** This set of charts indicates operating limits specific to the telehandler model and attachments. Refer to [Section 5.11](#).
- 20 Positive Air Shutoff Valve Test Switch (If Equipped)** : This switch is used for testing the functionality of the positive air shut-off valve. It allows the operator to shut off the air supply to the engine if the engine continues running after the main power is shut down. (Refer to [Section 3.5-7](#)). The indicator light illuminates red for a few seconds when testing the functionality of positive air shut-off valve.
- 21 Road Lights Switch (If Equipped)** : This switch activates the front headlights and rear tail lights.
- 22 Work Lights Switch (If Equipped)** : This switch activates the front and rear work lights located on top of operator's cab.
- 23 Boom Lights Switch (If Equipped)** : The boom light switch controls the light at the end of the boom.
- 24 Steer Mode Switch:** This switch has three positions to allow selection of four-wheel steer, front steer and crab steer.
- 25 Hydrostatic Pump Speed Control (If Equipped):** This knob controls the speed of the hydrostatic pump.

3.4 Safety Features and Devices

3.4-1 Reverse Alarm

The alarm produces an audible sound when REV is selected on the direction control lever.

3.4-2 Parking Brake

This spring-applied, hydraulically-released brake is activated by pressing the park brake switch on the dash. It must be applied when parking the machine or in an emergency. In the event of hydraulic pressure loss the parking brake will automatically activate.

3.4-3 Operator's Cab

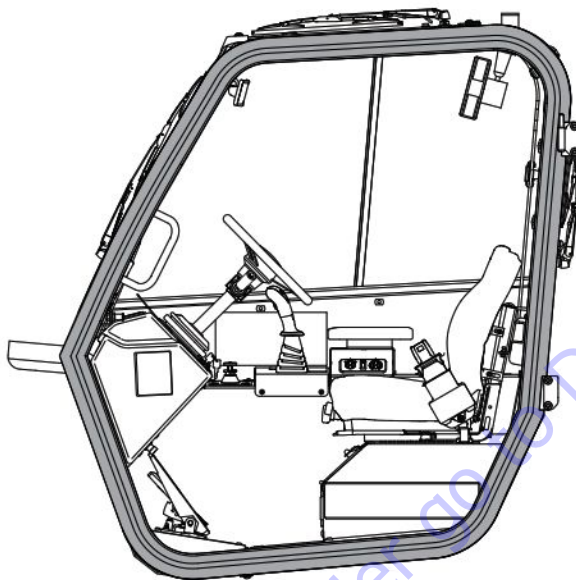

The operator's cab allows vision from all sides and is equipped with a falling object protection structure (FOPS) and a rollover protection structure (ROPS).

⚠ WARNING

Do not make any modification to FOPS or ROPS structures. If damaged, the cab cannot be repaired. It must be replaced.

A fully-enclosed cab with windows and door is available as an option. Included in this option are the windshield wiper(s), interior light and air heater/defroster. Air conditioner is also available as an option for fully enclosed cab.

3.4-4 Operator's Seat



- 1 Seat Belt:** The operator's seat is equipped with a seat belt. Use this seat belt at all times when operating telehandler.

⚠ WARNING

The seat belt must be worn at all times.

- 2 Seat:** The telehandler seat is equipped with devices which allow for the adjustment of seat ride smoothness and distance from the controls. Adjust the seat so that foot pedals, steering wheel and instrument panel controls are within easy reach of the operator.
- 3 Fore and Aft Lock Lever:** This lever is located on the left side of the seat. Pushing the lever to the left unlocks the seat, allowing fore and aft adjustment.
- 4 Ride Control (If Equipped):** The ride control is located at the front of the seat and is operated by means of a rotary knob. Clockwise rotation decreases the firmness while counterclockwise rotation increases the firmness.

3.4-5 Frame Level

The frame level indicator, mounted above the windshield in the operator's cab, displays the current frame level measurement.

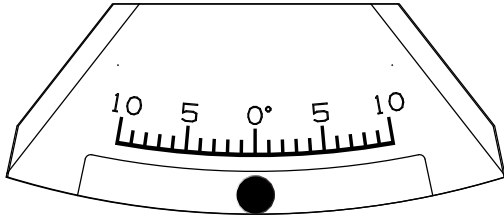

Figure 05 Frame Level Indicator

3.5 Optional Equipment

The following descriptions are for identification, explanation and locating purposes only.

3.5-1 Positive Air Shutoff Switch (If Equipped)

This system provides emergency over-speed shutdown protection for the engine. The engine will shut down and a red indicator light on the dash will illuminate for a few seconds.

When red indicator light is illuminated, telehandler will have no power and engine will not turn on.

3.5-2 Flashing Beacon (If Equipped)

The flashing beacon is located on top of the operator's cab. This light is operational when key is in on I position.

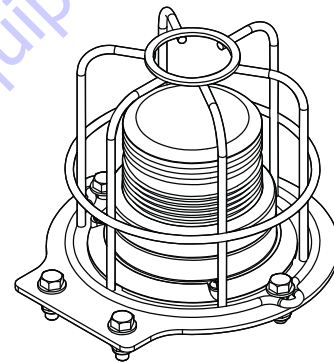

Figure 06 Flashing Beacon

3.5-3 Road Lights, Boom Lights & Work Lights (If Equipped)

The boom lights are mounted at the front of the main boom section.

The work lights are mounted on the frame as well as on top of the operator's cab.

The road lights (front headlights and taillights) have 2 settings; high beam and low beam headlights.

3.5-4 Fire Extinguisher (If Equipped)

The fire extinguisher is mounted to the frame at the rear left side of the telehandler, beside the engine air intake access door.

3.5-5 Back-up Sensor with Display Buzzer (If Equipped)

The back-up display buzzer is mounted to the dash inside the cab and warns the operator of objects behind the telehandler. When an object is detected, the buzzer beeps continuously and the **range indicator lights 1** illuminate. As objects become closer, beeping increases in frequency and more range indicator lights illuminate.

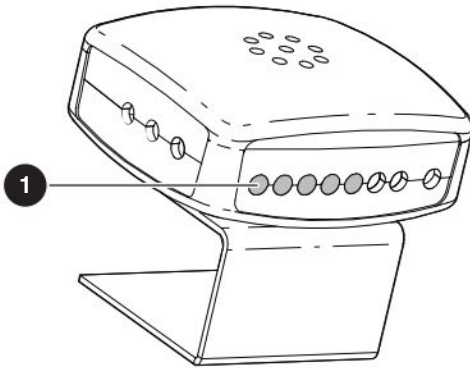

Figure 07 Back-up Display Buzzer

- 1 **Range Indicator Lights:** These lights illuminate from left to right to indicate a relative distance to the closest detected object.

3.5-6 Back-up Sensor/Camera with Monitor (If Equipped)

The back-up monitor is mounted on the dash inside the cab and operational when the key switch is in on position. When active, the monitor displays the area behind the telehandler. A green **status symbol 3** indicates the sensor and camera are connected and no objects are detected.

When in reverse and objects are detected, the monitor beeps, the status symbol turns red, and **range symbols 2** indicate distance to the objects. As objects become closer the range symbols increase in number and change to red. Five symbols indicate immediate proximity.

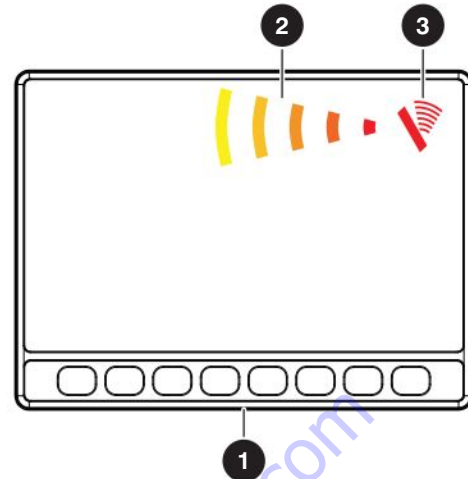

Figure 08 Back-up Monitor and Symbols

- 1 **Back-up Monitor**
- 2 **Range Indicator symbols**
- 3 **Sensor/Camera status symbol**

3.5-7 Tilt Steering Option (If Equipped)

The tilt steering option allows the angle of the steering wheel to be adjusted (refer to [Section 5.7-1](#)).

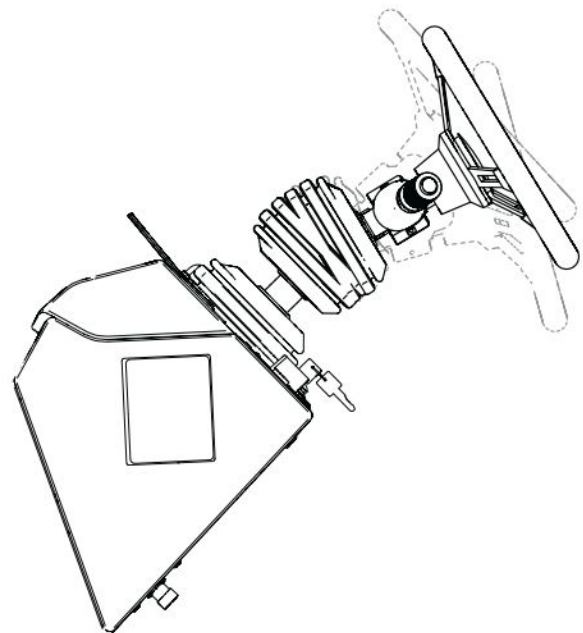

Figure 09 Tilt Steering Option

3.6 Optional Attachments

The Skyjack TH series telehandler is designed to accept a variety of optional **Quick Attach** attachments aside from regular fork carriage attachment.

3.6-1 Side Tilt Carriage

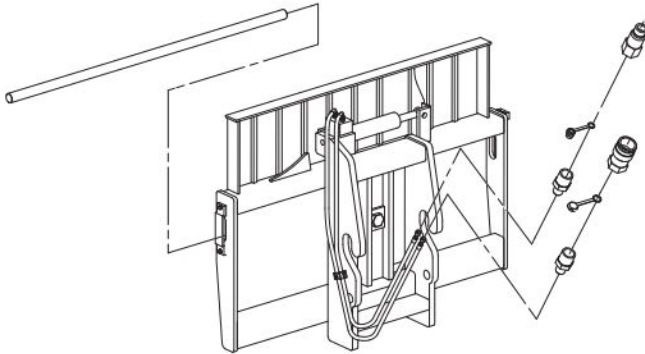

Figure 10 Side Tilt Carriage

The side tilt carriage allows carriage to tilt to either side.

Installation Procedure

1. Remove fork attachment or other attachment from boom and connect side tilt carriage attachment (refer to [Section 5.12-1](#) and [Section 5.12-2](#)).

Operation

1. **Make sure** the side tilt carriage attachment is positioned perpendicular to the **load**, and that **the load is centered with the carriage**.
2. To tilt the carriage left, hold **the** left auxiliary function button down. To tilt the carriage right, hold right auxiliary function button down.
3. Handle the load in the same way as a regular fork carriage attachment (refer to [Section 5.7](#) and [Section 5.8](#)).

3.6-2 Side Shift Carriage

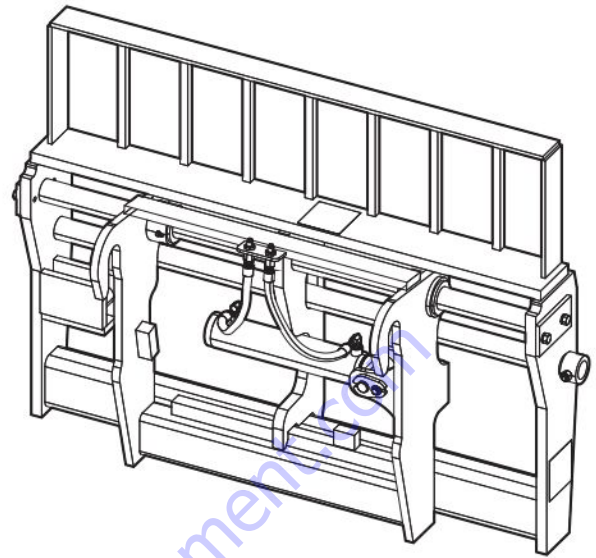

Figure 11 Side Shift Carriage

This attachment enables the entire carriage to be hydraulically shifted from side to side.

Installation Procedure

1. Remove fork attachment or other attachment from boom and connect side shift carriage attachment (refer to [Section 5.12-1](#) and [Section 5.12-2](#)).
2. Connect auxiliary hydraulic hoses to the side shift cylinder.

Operation

1. **Make sure** the side tilt carriage attachment is positioned perpendicular to the load.
2. To shift the carriage left, hold left auxiliary function button down. To shift the carriage right, hold right auxiliary function button down.
3. **Before traveling**, center the attachment to the sub-carriage and make sure the load is centered with the carriage. Handle the load in the same way as a regular fork carriage attachment (refer to [Section 5.7](#) and [Section 5.8](#)).

3.6-3 Block Forks

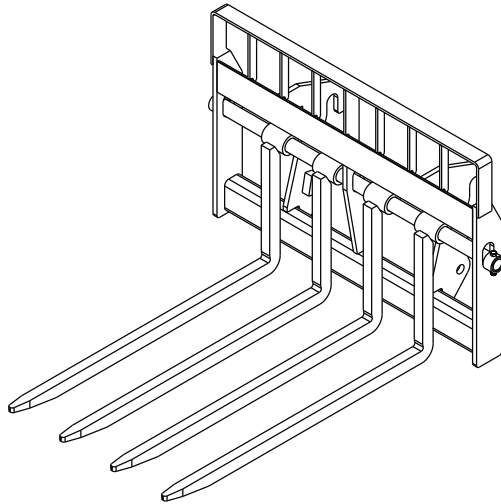

Figure 12 Block Forks

The block forks are used primarily to load/unload and place cubes of concrete or cement blocks. Block forks are designed to be accepted on all carriages provided they are equidistant.

Installation Procedure

1. Refer to [Section 5.12-6](#) to change the forks.

IMPORTANT

Make sure the forks are equally spaced.

Operation

1. Using optional attachment controller, **make sure** the carriage attachment and forks are positioned perpendicular to the load, and that the load is centered with the carriage.
2. Handle the load the same as a regular fork attachment, making sure all the forks are in contact with the load at all times (refer to [Section 5.7](#) and [Section 5.8](#)).

3.6-4 Skid Steer Adapter

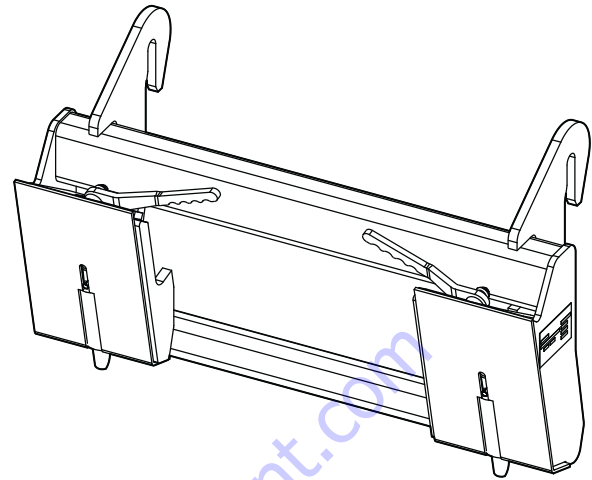

Figure 13 Skid Steer Adapter

This adapter is placed over the quick attach and allows the use of a range of skid steer style attachments.

Installation Procedure

1. Refer to [Section 5.12](#) for details on installing attachments.

3.6-5 Truss Boom

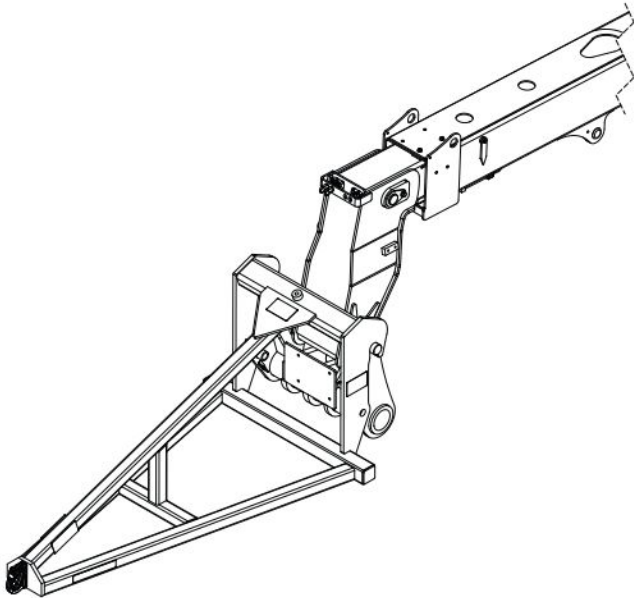

Figure 14 Truss Boom

A truss boom is an attachment with a hook or jib eye load connection. This connection is used for extending the forward reach and lift height of the telehandler at the expense of load capacity.

⚠ WARNING

Mounting truss boom changes center of gravity of telehandler. Consult capacity charts specific to attachment before handling loads.

Installation Procedure

1. Remove fork attachment or other attachment from boom and connect truss boom attachment (refer to [Section 5.12-1](#) and [Section 5.12-2](#)).

Operation

1. Using boom controller, adjust truss boom over the center of the load.
2. Attach load to the pintle hook using sufficient chains/cables.
3. While helpers guide the load, position load at placement point.

3.6-6 Loader Bucket

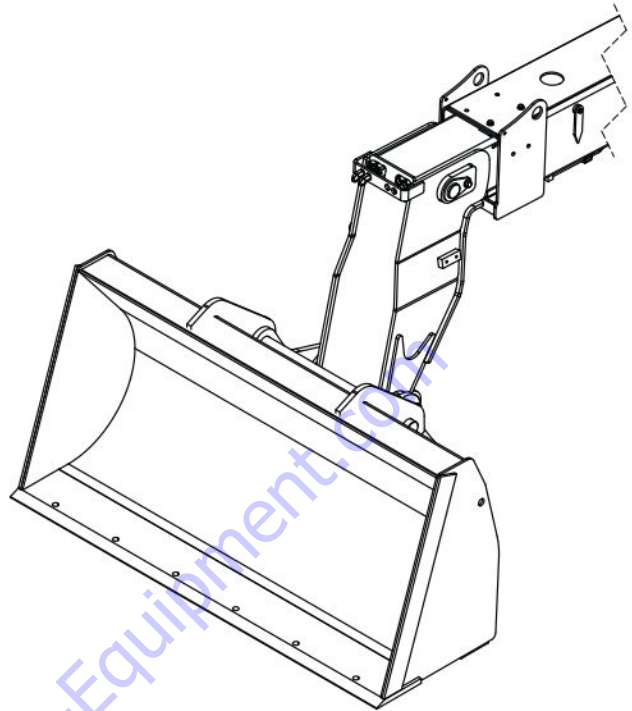

Figure 15 Loader Bucket

A loader bucket has a high back and straight sides for cutting into piles of low density materials. This attachment is used for light material handling such as snow removal or transporting of grains and other loose materials. Material buckets are not meant for excavation as high twisting loads can damage the boom.

Installation Procedure

1. Remove fork attachment or other attachment from boom and connect material bucket (refer to [Section 5.12-1](#) and [Section 5.12-2](#)).

Operation

1. Raise or lower boom to appropriate height for loading material from stockpile.
2. Position telehandler so that it is perpendicular to the stockpile. Drive slowly and smoothly into pile to load bucket.
3. Tilt bucket backwards enough to retain the load and back away from pile.
4. Drive to the unloading point and keep bucket approximately 4 ft above the ground.
5. Tilt bucket forward to dump load.

Section 4 – Pre-operation

4.1 Operator's Responsibility

It is the responsibility of the operator, prior to each work shift, to perform the following:

1. Visual and Daily Maintenance Inspections

- Designed to discover any damage of components before the telehandler is put into service.
- Completed before the operator performs the function tests.

WARNING

Failure to locate and repair damage, and discover loose or missing parts may result in an unsafe operating condition.

2. Function Tests

- Designed to discover any malfunctions before the telehandler is put into service.

IMPORTANT

The operator must understand and follow the step-by-step instructions to test all telehandler functions.

The operator should make a copy of the Operator's Checklist (see [Section 4.4](#)) and fill out the visual and daily maintenance inspections and the function tests sections while performing the items outlined in this section.

IMPORTANT

If telehandler is damaged or any unauthorized variation from factory-delivered condition is discovered, telehandler must be tagged and removed from service.

Repairs to the telehandler may only be made by a qualified service technician. After repairs are completed, the operator must perform visual and daily maintenance inspections & function tests again.

Scheduled maintenance inspections shall only be performed by a qualified service technician.

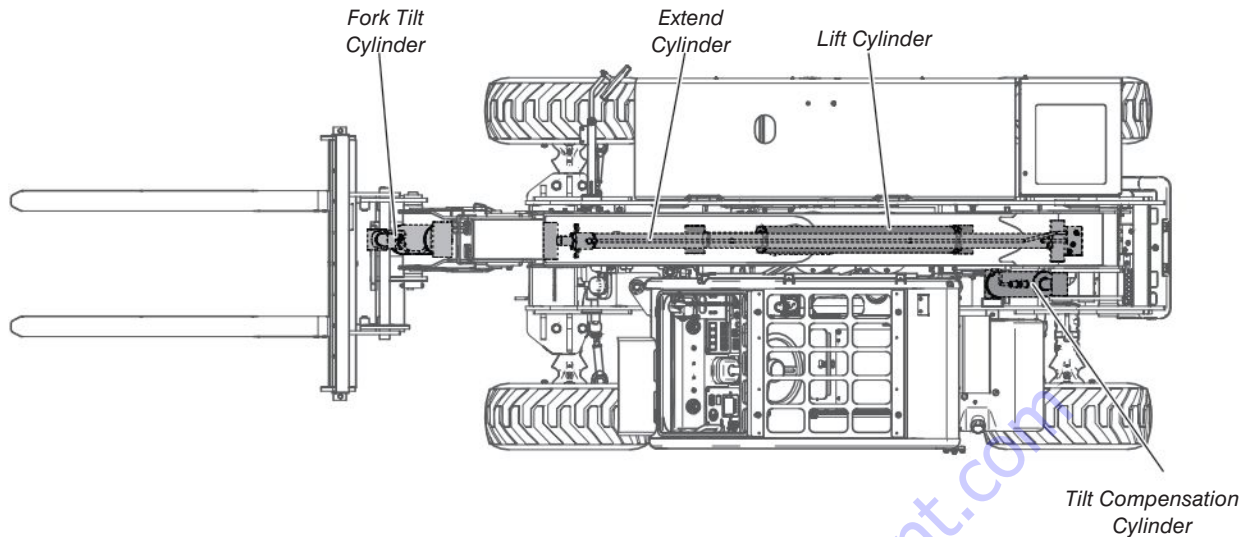

4.2 Visual & Daily Maintenance Inspections

Before performing the visual and daily maintenance inspections, ensure that the telehandler is parked on a firm level surface.

Begin the visual and daily maintenance inspections by checking each item in sequence for the conditions listed in this section.

WARNING

To avoid injury, do not operate a telehandler until all malfunctions have been corrected.

WARNING

To avoid possible injury, ensure telehandler power is off during your visual and daily maintenance inspections.

NOTE

While performing visual and daily inspections in different areas, be aware to also inspect all switches, electrical and hydraulic components.

4.2-1 Labels

Refer to the [Section 8 – Labels](#) in this manual and determine that all labels are in place and are legible.

4.2-2 Electrical

Maintaining the electrical components is essential to good performance and service life of the telehandler.

Ensure proper operation of all gauges.

Inspect the following areas for chafed, corroded and loose wires:

- boom wiring harnesses
- frame wiring harnesses
- cab wiring harnesses

Ensure electrical devices are properly secured with no visible damage. Ensure there are no loose or missing parts.

4.2-3 Hydraulic

Maintaining the hydraulic components is essential to good performance and service life of the telehandler. Perform a visual inspection and check for leaks around the following areas:

- hydraulic tank, filter(s), fittings, hoses, pump, and frame surface
- all hydraulic cylinders
- all hydraulic manifolds
- underside of the frame
- ground area under the telehandler

4.2-4 Cylinders

Ensure all cylinders are properly secured and there is no evidence of leakage.

Grease weekly and check pins and bushings to ensure there is no evidence of damage.

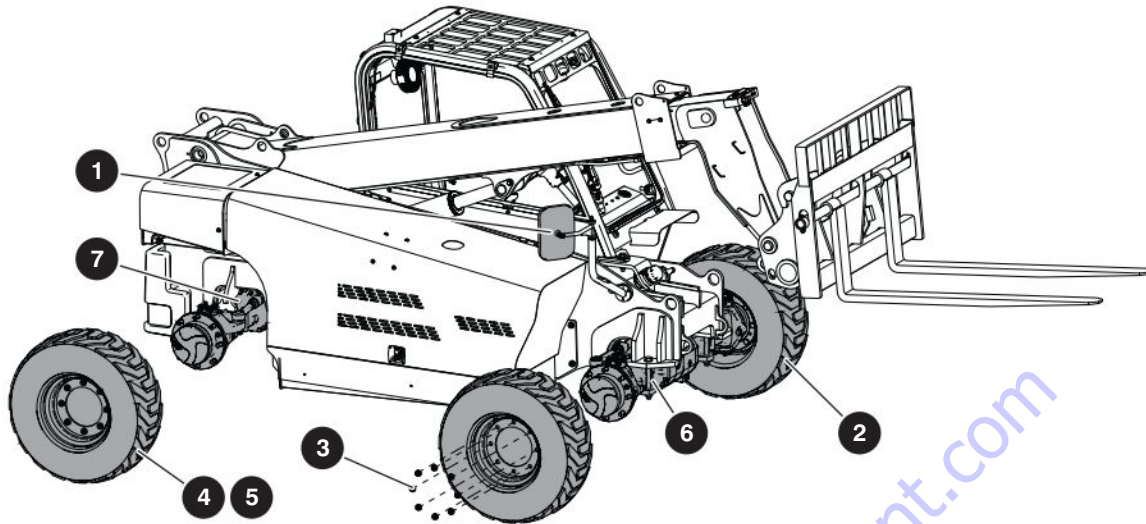

4.2-5 Mirrors

- 1 **Mirrors:** Ensure mirrors are properly secured with no visible damage.

4.2-6 Frame

- 2 **Wheel/Tire Assembly:** Tire and/or wheel failure could result in a telehandler tip-over. Component damage may also result if problems are not discovered and repaired in a timely fashion.
 - Check all tire treads and sidewalls for cuts or cracks that expose the cord plies.
 - Check for punctures, holes and unusual wear.
 - Check each wheel rim for damage and cracked welds.
 - Check each **lug nut** 3 for proper torque to ensure none are loose. Refer to *Section 7.3* for wheel/tire specifications.
- 4 **Air-filled Tires:** To safeguard maximum stability, achieve optimum telehandler handling and minimize tire wear, it is essential to maintain proper pressure in all air-filled tires. Refer to tire pressure label.
 - Check each tire with an air pressure gauge and add air as needed.

WARNING

An improperly inflated tire may cause death or serious injury.

- 5 **Foam-filled Tires:** Tire condition can vary significantly depending on telehandler use, job site environment and preventative maintenance

measures. Inspect tires periodically and pay extra attention to the following:

- Check for punctures or holes. Ensure they do not exceed a diameter of 2.54 cm (1 in).

WARNING

If any tire does not meet the criteria outlined above, remove telehandler from service and replace wheel/tire immediately.

WARNING

Do not use tires other than those specified for this machine. Do not mix different types of tires. Tires other than those specified can adversely affect stability. Failure to operate with matched, approved tires in good condition can result in death or serious injury. Replace tires with exact, Skyjack-approved types only.

6 **Drive Axles**

- Ensure drive axles are properly secured, there are no loose or missing parts, all fittings and hoses are properly tightened and there is no evidence of oil leakage.

7 **Steer Cylinder**

- Ensure steer cylinders are properly secured, there are no loose or missing parts, all fittings and hoses are properly tightened and there is no evidence of hydraulic oil leakage.

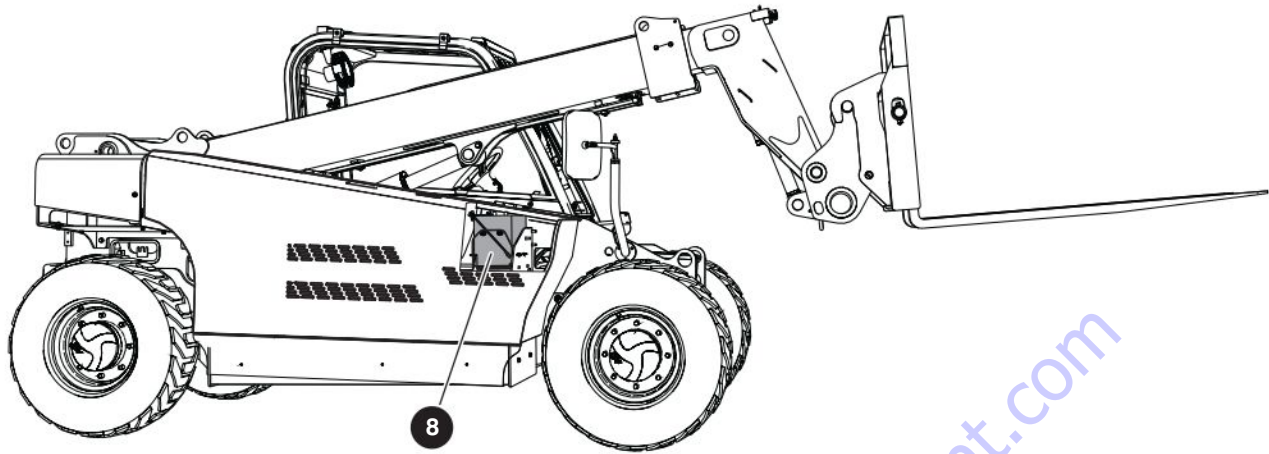

- 8 Battery:** Proper battery condition is essential to good engine performance and operational safety. Improper fluid levels or damaged cables and connections can result in engine component damage and hazardous conditions.

⚠ WARNING

Battery acid is extremely corrosive. Wear proper eye and facial protection as well as appropriate protective clothing. If contact occurs, immediately flush with cold water and seek medical attention.

1. Check battery case for damage.
2. Clean battery terminals and cable ends thoroughly with a terminal cleaning tool or wire brush.
3. Ensure all battery connections are tight.
4. If applicable, check battery fluid level. If plates are not covered by at least 13 mm (1/2 in) of solution, add distilled or demineralized water.
5. Replace battery if damaged or incapable of holding a lasting charge.

⚠ WARNING

Use original or manufacturer-approved parts and components for the telehandler.

⚠ WARNING



Explosion hazard. Keep flames and sparks away. Do not smoke near batteries.

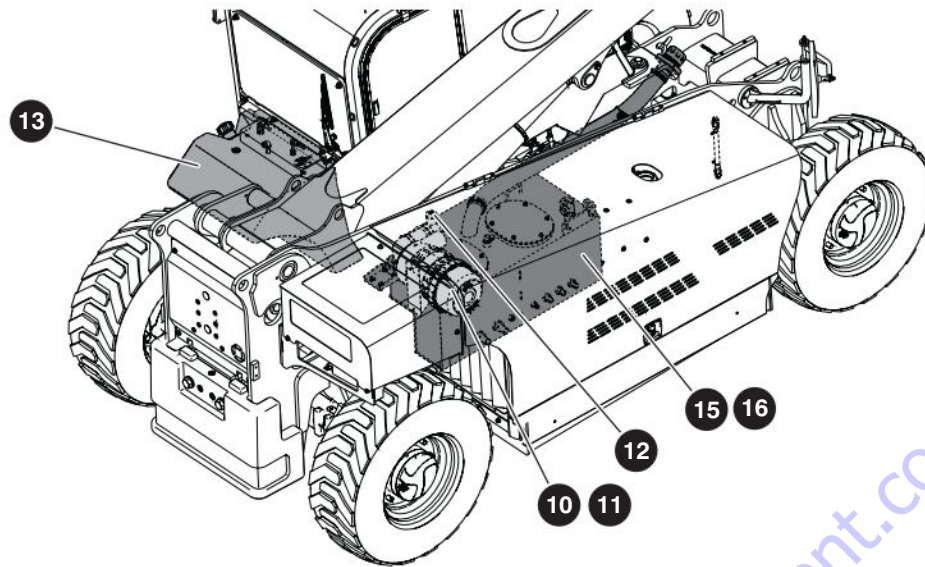

10 Engine Intake Air Filter

- Ensure there are no loose or missing parts and there is no visible damage.
- Ensure **air cleaner vacuator valve** 11 is free from dirt or dust by squeezing the valve lips.
- Check **air cleaner service indicator** 12 and replace filter element if needed.

13 Fuel Tank 

IMPORTANT

Before using your telehandler ensure there is enough fuel for expected use.

- Ensure fuel filler cap is secure.
- Ensure tank shows no visible damage and no evidence of fuel leakage.
- **Fuel Leaks:** Failure to detect and correct fuel leaks will result in an unsafe condition. An explosion or fuel fire may cause death or serious injury. Perform a visual inspection around the following areas:
 - hoses and fittings
 - fuel pump
 - fuel filter
 - fuel tank
- Be sure to follow all local, provincial/territorial/state and national regulations related to disposing of fluids and soiled rags, cloths, etc.

⚠ WARNING

Engine fuels are combustible. Inspect the telehandler in an open, well-ventilated area away from heaters, sparks and flames. Always have an approved fire extinguisher within easy reach.

15 Hydraulic Oil Tank

- Ensure hydraulic filler cap is secure.
- Ensure tank shows no visible damage and no evidence of hydraulic leakage.

16 Hydraulic Oil 

- Be sure that the boom is in the lowered and stowed position, and then visually inspect the sight gauge located at the rear of the hydraulic oil tank.
- Add fresh, clean hydraulic oil as required. Refer to [Section 7.4](#) for recommended oil type.
- Be sure to follow all local, provincial/territorial/state and national regulations related to disposing of fluids and soiled rags, cloths, etc.

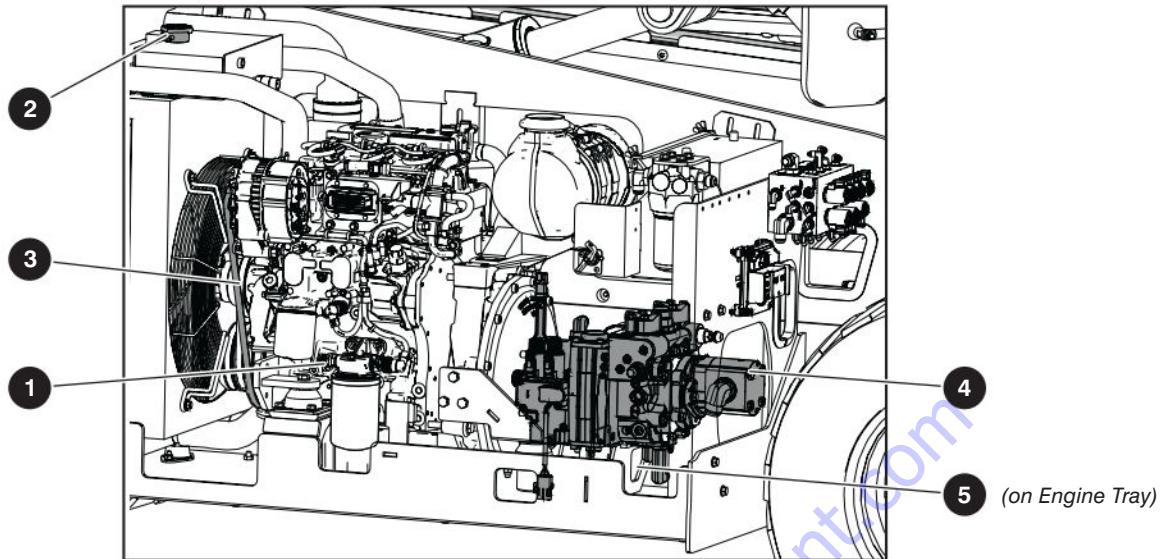

4.2-7 Engine Compartment

- Ensure compartment cover is secure and in proper working order.

⚠ WARNING

Beware of hot engine components.

1 Engine Oil Level on Dipstick

Maintaining the engine components is essential to good performance and service life of the telehandler.

- Oil level should be between the L (low) and H (high) marks. Add oil as needed. Refer to [Section 7.4](#) for recommended oil type.

2 Engine Coolant

⚠ WARNING

Pressurized fluid present in radiator. Never open radiator cap when hot.

- Check coolant level on radiator.
- Add coolant as required.
- Be sure to follow all local, provincial/territorial/state and national regulations related to disposing of fluids and soiled rags, cloths, etc.

3 Belts

- Ensure belts are in good working condition and have correct tension. Replace if belts are cracked, frayed, or have chunks of material missing. Refer to service manual for proper replacement procedure.

4 Hydraulic Oil Pump

- Ensure there are no loose or missing parts and there is no visible damage.
- Ensure all bolts are properly tightened.
- Ensure all fittings and hoses are properly tightened and there is no evidence of hydraulic oil leakage.

5 Fuel/Water Separator

- Ensure there are no loose or missing parts and there is no visible damage.
- Ensure all fittings and hoses are properly tightened and there is no evidence of fuel leaks.
- Drain water by opening water drain plug at bottom of filter. Close tightly after inspection.

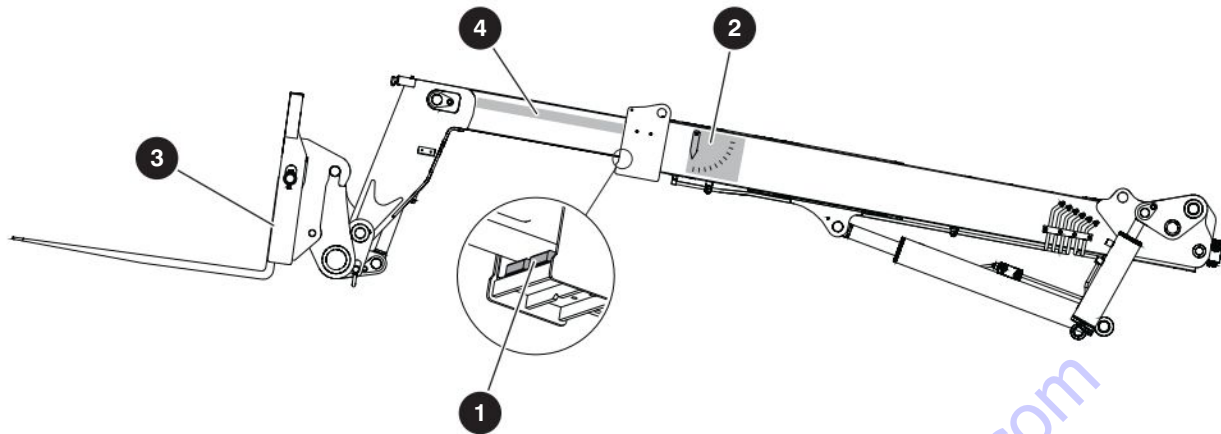

4.2-8 Boom

- Ensure there are no loose or missing parts and there is no visible damage.
- Ensure all bolts and pins are properly tightened.
- Ensure there are no visible cracks in welds or structure and there are no signs of deformation.
- Ensure all hoses are properly tightened and there is no evidence of hydraulic leakage.

1 Slide Pads

- Ensure all bolts are tight, there is no visible damage to the slide pads and that no parts are missing.

2 Boom Angle Indicator

- Ensure all bolts are tight, and there is no visible damage and indicator swings freely.

4.2-9 Lifting Attachment

- 3** Ensure attachment is properly positioned and secured. (Refer to [Section 5.12](#)).
- Ensure there are no loose or missing parts and there is no visible damage.

4.2-10 Grease Points

Maintaining properly greased components is essential for good performance and service life of the telehandler. If components are improperly greased, it could result in component damage.

- 4** Greased component locations

⚠ WARNING

Ensure that there are no personnel or obstructions in maintenance area.

Greasing intervals are based on average telehandler usage. Use of telehandler may vary significantly and greasing frequency must be adjusted to obtain maximum service life.

Refer to the Daily & Weekly Maintenance Chart located inside operator’s cab for grease points location and service intervals.

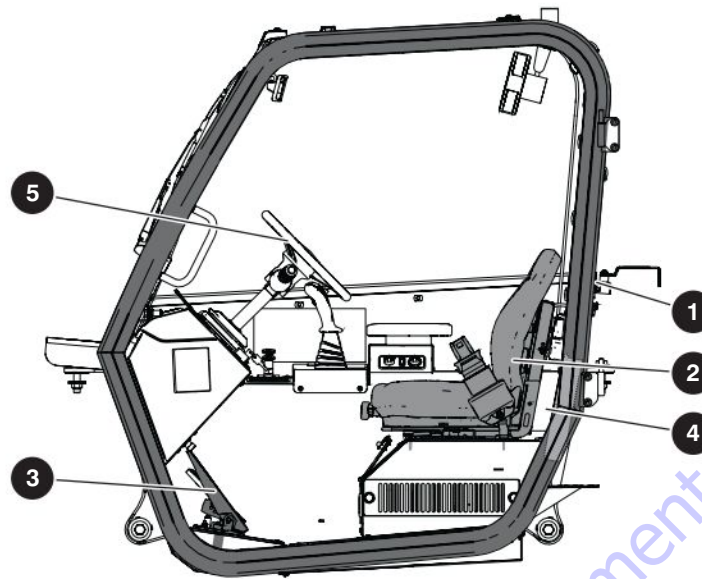

4.2-11 Operator's Cab

1 Rollover and Falling Object Protective Structure (ROPS/FOPS)

- Ensure there is no visible damage.

⚠ WARNING

Do not modify, drill or alter the operator's cab in any way.

2 Seat

- Ensure seat is properly secured with no visible damage.
- Ensure seat belt is working properly with no visible damage.

3 Pedals

- Ensure brake and accelerator pedals are secure, no loose or missing parts, no visible damage and movements are not obstructed.

4 Manual

- Check to be sure manual storage box is present and in good condition.
- Ensure a copy of operating manual, and other important documentation are enclosed in manual storage box.
- Ensure manual is legible and in good condition.
- Always return manual to the manual storage box after use.

5 Tilt Steering (If Equipped)

- Ensure steering wheel is properly secured with no visible damage.
- Ensure the tilt steering mechanism is working properly with no visible damage.

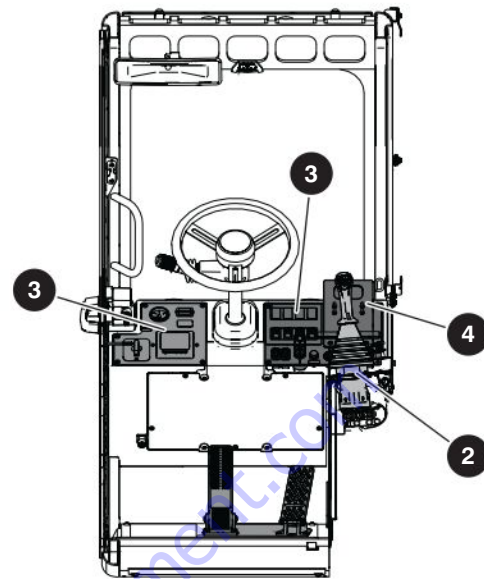
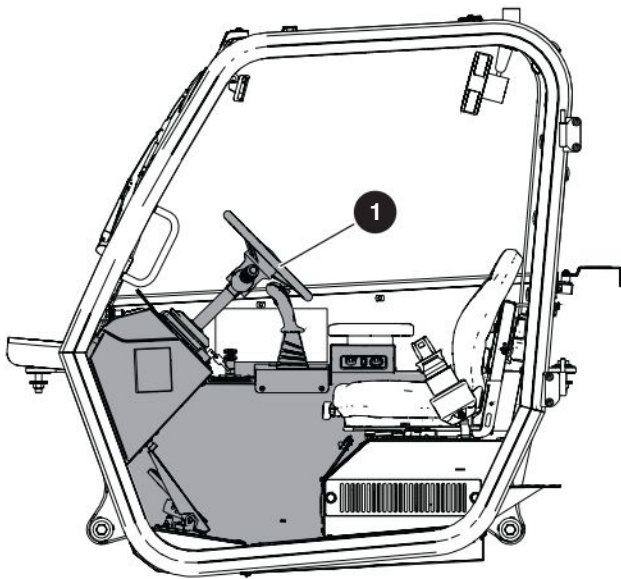

4.2-12 Operator's Cab Controls

⚠ WARNING

Ensure that you maintain three points of contact to mount/dismount the cab.

- Use the steps of telehandler to access operator's cab.
- Ensure door and windows (if equipped) are secure and in proper working order.
- Ensure **operator's cab controls** ① (refer to [Section 3.3-1](#)) are secured with no visible damage.
- Ensure **multi-functional joystick** ② (refer to [Section 3.3-2](#)) is secured, movements are not obstructed and, with no visible damage.
- Ensure **operator's dash controls** (refer to [Section 3.3-3](#)) ③ are properly secured, returned to their neutral position, with no visible damage.
- Ensure **capacity charts** ④ are in place and are legible.

⚠ WARNING

Do not operate the telehandler if capacity charts are missing or not legible.

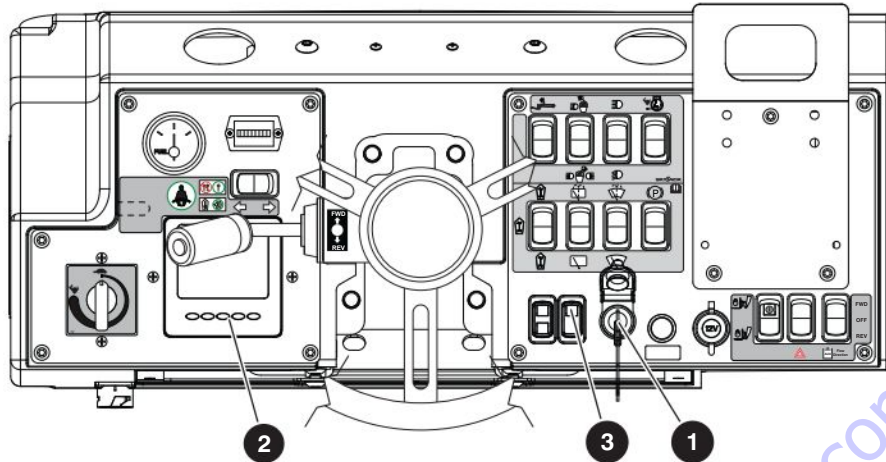

4.3 Function Tests

Function tests are designed to discover any malfunctions before telehandler is put into service. The operator must understand and follow step-by-step instructions to test all telehandler functions.

Prior to performing function tests, be sure to read and understand [Section 5 – Operation](#).

IMPORTANT

Never use a malfunctioning telehandler. If malfunctions are discovered, telehandler must be tagged and placed out of service. Repairs to telehandler may only be made by a qualified service technician. After repairs are completed, the operator must perform visual and daily maintenance inspections & function tests again.

WARNING

Ensure that there are no personnel or obstructions in test area and that there is sufficient room to test all telehandler functions.

4.3-1 Test Starter Operation

WARNING

Ensure that you maintain three points of contact to mount/dismount the cab.

1. Enter cab and close door (if equipped).

WARNING

The seat belt must be worn at all times.

2. Sit in the driver's seat and fasten seat belt.
3. Using a spotter, adjust the mirrors.
4. Ensure parking brake is engaged and shift lever is in neutral. Ensure all controls/switches are in neutral position.
5. Insert key into **ignition switch 1** and select on | position.
 - **Result: Engine data display module 2** and **glow plug indicator light 3** should turn on.
6. Wait until glow plug indicator light turns off then turn the key to start position until engine starts then return key to on | position.

WARNING

DO NOT over crank the starter. Do not crank for more than 15 seconds. Wait for 15 minutes before attempting to start engine again. If engine fails to start after multiple attempts, contact qualified/competent repair personnel.

IMPORTANT

If the DEUTZ Engine Display Module displays an error message when engine is running, immediately shut down the telehandler and have it serviced.

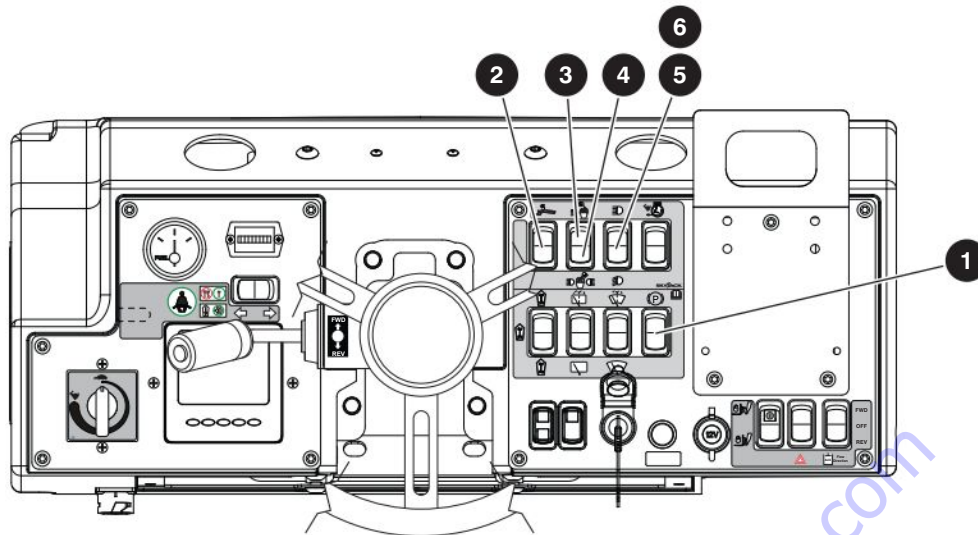

4.3-2 Test Horn

1. Push horn  on steering wheel.
 - **Result:** Horn should sound.

4.3-3 Test Lights (If Equipped)

1. Use a spotter to check if all lights are working well. The spotter should maintain a safe distance from telehandler.
2. Turn **parking brake switch** ① to off position.
 - **Result:** Rear brake lights should turn off.
3. Depress service brake pedal.
 - **Result:** Rear brake lights should turn on.
4. Select **boom lights switch** ② (if equipped) to on position.
 - **Result:** Boom lights should turn on.
5. Select the **front work lights switch** ③ (if equipped) to on position.
 - **Result:** Front work lights should turn on.
6. Select the **front/rear work lights switch** ④ (if equipped) to on position.
 - **Result:** Front/rear work lights should turn on.
7. Select **low beam headlights switch** ⑤ to on position.
 - **Result:** low beam headlights and tail light should turn on.
8. Select **high beam headlights switch** ⑥ to on position.
 - **Result:** High beam headlights & taillights should turn on.

Multi-functional Joystick

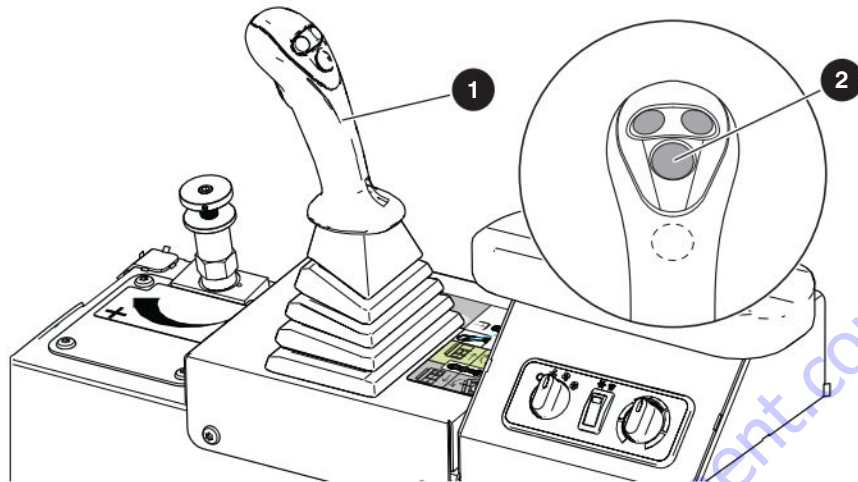

4.3-4 Test Boom Functions

WARNING

Ensure there are no personnel or obstructions in test area and there is sufficient room to test all telehandler functions.

1. Ensure the park brake is engaged.
2. Raise the boom by moving the **joystick** ① backward.
 - **Result:** Boom should raise and boom angle indicator should be functioning.
3. Extend the boom by moving the joystick to the right.
 - **Result:** Boom should extend and boom extension indicators are visible.
4. Retract the boom by moving the joystick to the left.
 - **Result:** Boom should retract.
5. Lower the boom by moving the joystick forward.
 - **Result:** Boom should lower.
6. Lower the boom until attachment is approximately 0.61 m (2 ft) above the ground.

4.3-5 Test Attachment Functions

Multi-functional Joystick:

1. Tilt attachment forward by pressing and holding the **carriage tilt enable button** ② while moving the joystick forward.
 - **Result:** Attachment should tilt forward.
2. Tilt attachment backward by pressing and holding the carriage tilt enable button while moving the joystick backward.
 - **Result:** Attachment should tilt backward.



NOTE

Ensure to test all attachment functions if telehandler is equipped with optional attachments. Refer to [Section 3.6](#) and [Section 5.12](#) for details about each attachment and installation/operation.

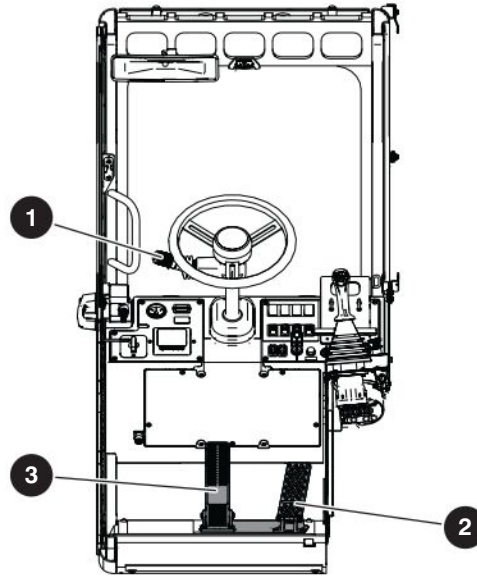

4.3-6 Test Accelerator Pedal

1. Ensure parking brake is engaged and **direction control lever ①** is in neutral.
2. Press **accelerator pedal ②** slowly.
 - **Result:** The engine RPM should increase.
3. Release the accelerator pedal.
 - **Result:** The engine RPM should decrease.

4.3-7 Test Reverse Alarm, Driving & Service Brake

1. Ensure park brake is engaged and transmission is in neutral.
2. Depress **service brake pedal ③** and ensure path of intended motion is clear.
3. Release parking brake.
 - **Result:** Parking brake indicator light should turn off.

4. Move direction control lever to REV reverse position and release the service brake pedal slowly.
 - **Result:** Telehandler should move backward and reverse alarm should sound.
5. Depress service brake pedal slowly.
 - **Result:** Telehandler should stop.
6. Move direction control lever to FWD and slowly release service brake pedal.
 - **Result:** Telehandler should slowly move forward.
7. Depress service brake pedal slowly.
 - **Result:** Telehandler should stop.
8. Return direction control lever to neutral position and engage parking brake.

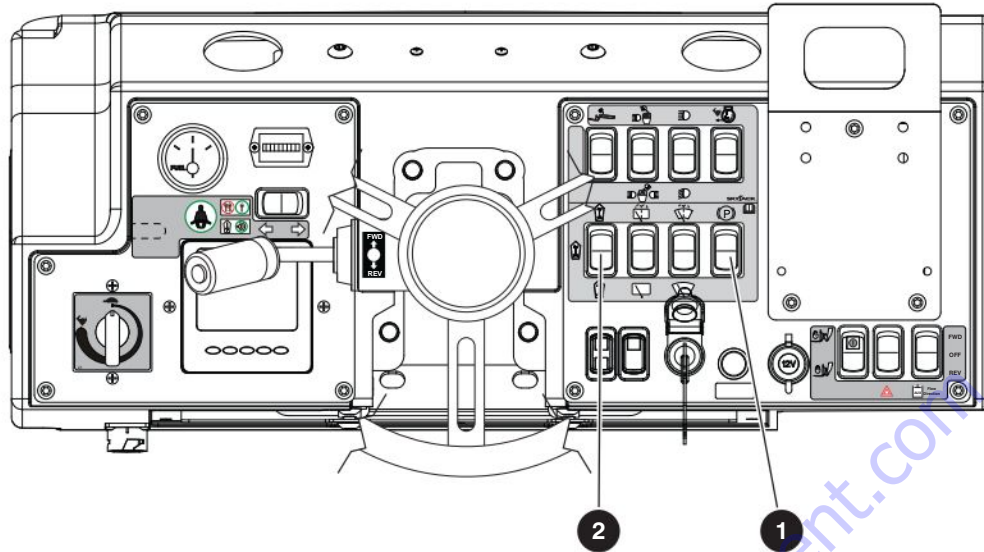

4.3-8 Test Parking Brake

WARNING

The seat belt must be worn at all times.

1. Ensure telehandler is on a firm, level surface.
2. Ensure the path of intended travel is clear and area around telehandler is clear of any personnel or obstructions.
3. Depress service brake, press the **park brake switch** (P) ① to off position.
 - **Result:** Parking brake indicator light should turn off.
4. Move direction control lever to FWD and slowly release service brake pedal.
 - **Result:** Telehandler should roll forward.
5. Press the park brake switch (P) to on position.
 - **Result:** Parking brake should engage, telehandler should stop immediately (less than two seconds), and parking brake indicator light should illuminate.

4.3-9 Test Steering

CAUTION

Before changing steering modes, bring all four wheels into alignment (i.e., in the straight-ahead position).

WARNING

Before driving on public roads and highways check the alignment of the wheels and drive with **FRONT** steering only.

WARNING

Do not change steer mode while telehandler is traveling.

NOTE

Avoid steering the wheels while telehandler is stationary.

1. Four-wheel Steering (Figure 16)

1. Ensure path of intended motion is clear.
2. Ensure all four wheels are aligned straight ahead.
3. Press the park brake switch (P) to off position and depress service brake pedal.
4. Press the upper portion of the **steer mode switch** ② for four-wheel steering.

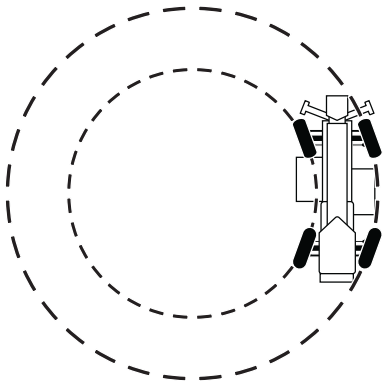

Figure 16 Four-wheel Steering

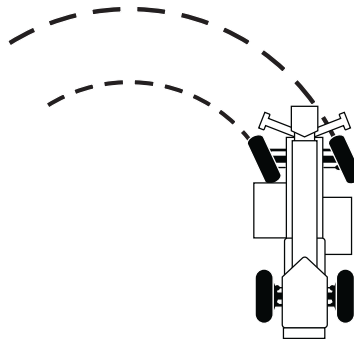

Figure 17 Front Steering

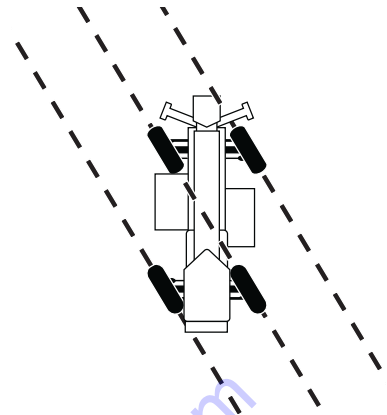

Figure 18 Crab Steering

5. Turn the steering wheel to the left or right and drive forward.
 - **Result:** Telehandler should move in the chosen direction, producing a turning circle, with front wheels pointing in the opposite direction to the rear wheels.
6. Steer telehandler straight ahead until all four wheels are aligned.
7. Depress service brake pedal until the telehandler stops.

WARNING

Do not use four-wheel steering mode when driving on public roads and highways.

Do not travel at a higher speed when using four-wheel steering mode.

2. Front Steering (Figure 17)

1. Place the steer mode switch to the middle position  for front steering.
2. Turn steering wheel to the left or right and drive forward.
 - **Result:** Only front wheels of the telehandler should turn in the chosen direction.
3. Steer telehandler straight ahead until all four wheels are aligned.
4. Depress service brake pedal until telehandler stops.

3. Crab Steering (Figure 18)

1. Press the lower portion of the steer mode switch to backward  for crab steering.
2. Turn the steering wheel left or right and drive forward.
 - **Result:** Telehandler should move in chosen direction with both front and rear wheels in the same direction.
3. Steer telehandler straight ahead until all four wheels are aligned.
4. Depress service brake pedal until telehandler stops.
5. Press the park brake switch (P) to on position.

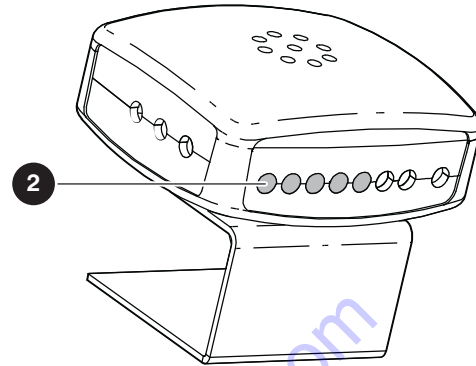
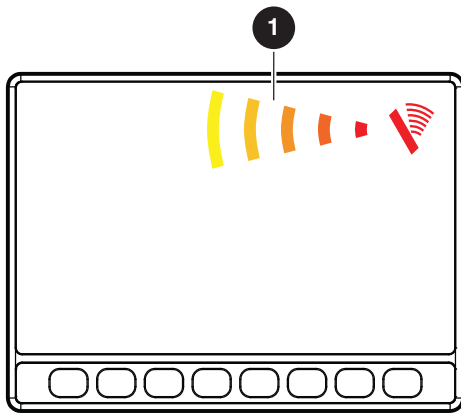

4.3-10 Test Back-up Sensor with Display Buzzer (If Equipped)

1. Ensure engine is running and key is in on position I.
2. Press the park brake switch (P) to on position and place direction control lever in reverse.
3. Press and hold service brakes pedal to prevent the telehandler from moving.
4. Press the park brake switch (P) to off position.
 - **Result: Range indicator lights 1** on the back-up sensor illuminate and beep if an object is detected behind telehandler.
5. Press the park brake switch (P) to on position.

4.3-11 Test Back-up Sensor/Camera with Monitor (If Equipped)

1. Ensure engine is running and key is in on position I.
 - **Result: Monitor** is active and displays area behind telehandler.
2. Ensure the park brake switch (P) is engaged and transmission is in reverse.
3. Depress and hold service brake pedal. Release parking brake.
 - **Result: Range symbols 2** should appear on the monitor and beep if an object is detected behind telehandler.
4. Press the park brake switch (P) to on position.

Table 4.4 Operator's Checklist



Operator's Checklist

Serial Number: _____
 Model: _____
 Hourmeter Reading: _____
 Date: _____
 Time: _____

Operator's Name (Printed): _____
 Operator's Signature: _____

Each item shall be inspected using the appropriate section of the Skyjack operating manual. As each item is inspected, check the appropriate box.

P PASS
F FAIL

R REPAIRED
N/A NOT APPLICABLE

	N/A	P	F	R
Visual and Daily Maintenance Inspections				
Labels				
Electrical				
Hydraulic				
Cylinders				
Mirrors				
Frame				
Wheel/Tire Assembly				
Air-filled Tires				
Foam-filled Tires				
Drive Axles				
Steer Cylinder				
Battery				
Outriggers				
Engine Intake Air Filter				
Fuel Tank				
Fuel Leaks				
DEF Tank				
Hydraulic Oil Tank				
Hydraulic Oil				
Engine Compartment				
Engine Oil Level on Dipstick				
Engine Coolant				
Belts				
Hydraulic Pump				
Fuel/Water Separator				
Transmission				
Oil Level on Dipstick				
Boom				
Boom Angle Switch				

	N/A	P	F	R
Slide Pads				
Chains				
Boom Angle Indicator				
Lifting Attachment				
Grease Fittings				
Operator's Cab				
ROPS/FOPS				
Seat				
Pedals				
Manual Storage Box/Manual				
Operator's Cab Controls				
Function Tests				
Operator's Cab Controls				
Test Starter Function				
Test Horn				
Test Lights (if equipped)				
Test Boom Functions				
Test Attachment Functions				
Test Frame Leveling and Level Indicator				
Test Boom Interlock and RAS System				
Test Accelerator Pedal				
Test Reverse Alarm, Driving and Service Brake				
Test Parking Brake				
Test Steering				
Test Outriggers (if equipped)				
Test Back-up Sensor with Display Buzzer (if equipped)				
Test Back-up Sensor/Camera with Monitor (if equipped)				

1235AB



NOTE: Make a copy of this page or visit the Skyjack website at www.skyjack.com for a printable copy.

Section 5 – Operation

This section provides the necessary information needed to operate the telehandler. Read and completely understand the operating manual and all warnings and instruction labels (refer to [Section 8 – Labels](#)) on the telehandler.

WARNING

DO NOT operate this telehandler without proper authorization and training. Doing so could result in death or serious injury.

Before operating this telehandler, perform the following tasks:

1. Visual and daily maintenance inspections (see [Section 4.2](#)).
2. Function tests (see [Section 4.3](#)).
3. Jobsite inspection (see [Section 2.4](#)).
4. If, as a result of the risk assessment, the need for rescue planning is identified, a system of communication shall be established between people working on the platform and nominated support personnel trained in the use of ground controls for platform retrieval.

WARNING

An operator should not use any telehandler that:

- does not appear to be working properly.
- has been damaged or appears to have worn or missing parts.
- has alterations or modifications not approved by the manufacturer.
- has safety devices which have been altered or disabled.
- has been tagged or blocked out for non-use or repair.

Failure to avoid these hazards could result in death or serious injury.

WARNING

DO NOT operate telehandler under engine power in an enclosed space. Use only in an open or well-ventilated area.

5.1 Starting the Engine

⚠ WARNING

Ensure that you maintain three points of contact to mount/dismount the cab.

1. Enter cab and close door (if equipped).
2. Sit in the driver's seat and fasten seat belt.

⚠ WARNING

The seat belt must be worn at all times.

3. Ensure parking brake is on and direction control lever in neutral position.
4. To start the engine, turn the ignition switch to on position. Turn the key to start position.

5.2 Driving the Telehandler

5.2-1 Driving on Level Terrain

⚠ WARNING

- Be aware of blind spots when operating the telehandler.
- Ensure that there are no personnel or obstructions in the path of travel, including blind spots.
- When traveling at high rate of speed, use front wheel steering mode.
- Slow the telehandler prior to turning.
- Always look at the direction of travel.
- Travel in reverse only at slow rate of speed.
- Drive only as fast as conditions allow.
- Keep attachment or load low (45.7 to 61 cm/18 to 24 in) to the ground which gives the best visibility and stability.

The telehandler is equipped with a hydrostatic transmission that has a forward and reverse gear.

1. Depress service brake pedal then lift and move direction control lever to the desired direction of travel.
2. Press the park brake switch (P) to off position.
3. Move the direction control lever to FWD and slowly release service brake pedal.
4. Depress accelerator pedal slowly to increase speed.

5. Use lower speed when transporting load, traveling through deep mud, rough terrain, or slopes. Travel at a higher speed during long distances on smooth terrain without a load.
6. Always bring the telehandler to a complete stop before changing the direction of travel.

5.2-2 Driving on Slopes

⚠ WARNING

Driving on slopes or inclines can be dangerous and may result in forklift tip-over or loss of load.

- Avoid excessively steep slopes or unstable surfaces. Do not drive across excessively steep slopes under any circumstances.
- Avoid turning on slopes, if at all possible.

1. Keep load low and proceed with caution.
2. Reduce travel speed before reaching a slope.
3. Ascend and descend slopes with the **heavy end** of the telehandler pointing up the slope:
 - **Without Load:** When the telehandler has no load, the rear is considered the **heavy end**. Travel with the attachment pointed downhill.
 - **With Load:** When the telehandler is carrying a load, the front is considered the **heavy end**. Travel with the attachment pointed uphill.

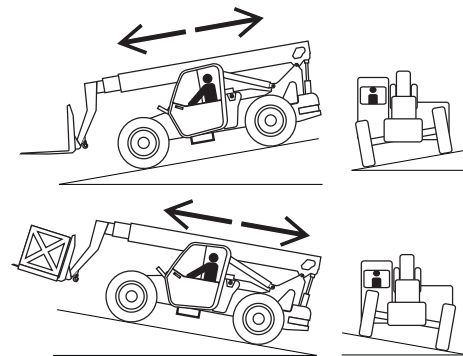

Figure 19 Driving on a Slope

5.3 Steering the Telehandler

Steering is controlled by means of the steering wheel in conjunction with the steer mode switch for the type of steering desired.

5.3-1 Four-wheel Steering

This steer mode is most commonly used on the job site and will give the smallest turn radius available.

WARNING

Do not use four-wheel steering mode when driving on public roads and highways.

Do not travel at a higher speed when using four-wheel steering mode.

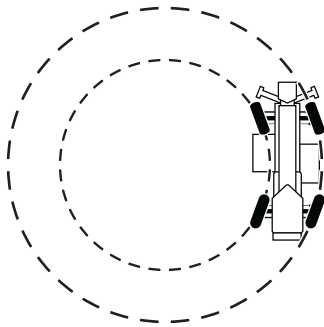

Figure 20 Four-wheel Steering

5.3-2 Front Steering (Two-Wheel)

Two-wheel steer is used during road travel in order to reduce the risk of possible overturn due to oversteering.

NOTE

Loss of electrical power will allow front steering only.

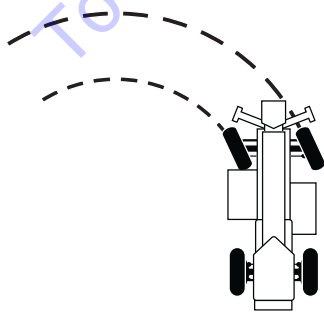

Figure 21 Front Steering

5.3-3 Crab Steering

The crab steer is used for maneuvering into tight spots.

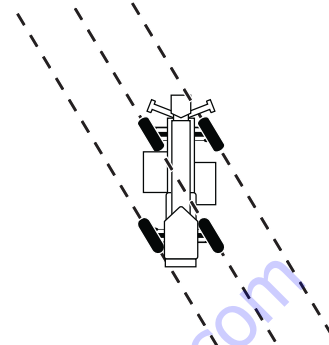

Figure 22 Crab Steering

5.3-4 Adjusting the Tilt Steering Wheel (If Equipped)

This option allows the operator to adjust the angle of the steering wheel.

WARNING

Ensure that you maintain three points of contact to mount/dismount the cab.

WARNING

Ensure that the tilt steering wheel is locked into position after adjustment.

1. Enter cab and close door (if equipped).
2. Sit in the driver's seat and fasten seat belt.

WARNING

The seat belt must be worn at all times.

3. Locate the push button in the steering column, and press it to release the tilt steering lock.
4. While pressing the push button, adjust the steering at the desired position and release the push button to lock the steering column.

5.4 Operating the Boom

5.4-1 Raising or Lowering Boom

WARNING

Ensure that there are no personnel or obstructions and there is sufficient room to perform all telehandler functions.

1. To raise the boom, move the joystick backward.
2. To lower the boom, move the joystick forward.
3. Release the joystick to stop.

5.4-2 Extending or Retracting Boom

WARNING

Ensure that there are no personnel or obstructions and there is sufficient room to perform all telehandler functions.

1. To extend the boom, move the joystick to the right. To retract the boom, move the joystick to the left.
2. Release the joystick to stop.

5.5 Tilting the Attachment

Multi-functional Joystick:

1. Tilt attachment forward by pressing and holding the carriage tilt enable button while moving the joystick forward.
 - **Result:** Attachment tilts forward.
2. Tilt attachment backward by pressing and holding the carriage tilt enable button while moving the joystick backward.
 - **Result:** Attachment tilts backward.



NOTE

Refer to [Section 3.6](#) for details about optional attachment operation.

5.6 Handling Loads

WARNING

- Before commencing operation, familiarize yourself with the capacity charts specific to telehandler model and attachment.
- Know the weight of the load and the most extreme height and distance required to pick or place the load.
- Do not lift load on a gradient steeper than 5%.
- Never position the load behind front face of the tires.
- Never drive the telehandler with the boom raised.
- Ensure not to exceed telehandler lift capacity (refer to capacity charts). Exceeding lift capacity could cause tip-over resulting in death or serious injury.
- When performing lift operation where the operator cannot see load at all times, the operator has to be assisted by a spotter using approved hand signals (refer to [Section 1.3](#)).

1. Drive as close as possible to load pickup/ placement site.
2. Place direction control lever into neutral position and press the park brake switch (P) to on position.
3. Use attachment to pickup/place the load. Refer to procedures outlined in [Section 3.6](#) for specific attachment uses.
4. If using fork attachment, tilt forks backward to stabilize the load.

5.7 Handling Loads at Ground Level

WARNING

- Handle only loads within the rated capacity as shown on the capacity charts mounted on the telehandler.
- Ensure the capacity chart used corresponds to the attachment fitted to the telehandler.
- Use only manufacturer's approved attachments. The use of non-approved attachments may cause telehandler instability and tip-over, which may result in death or severe injury to operators or bystanders.
- Ensure that the load center for the load is at or within 61 cm (24 in) of forks (refer to [Figure 23](#)).
- Use a spotter when possible to assist in handling the load (refer to [Section 1.3](#)).

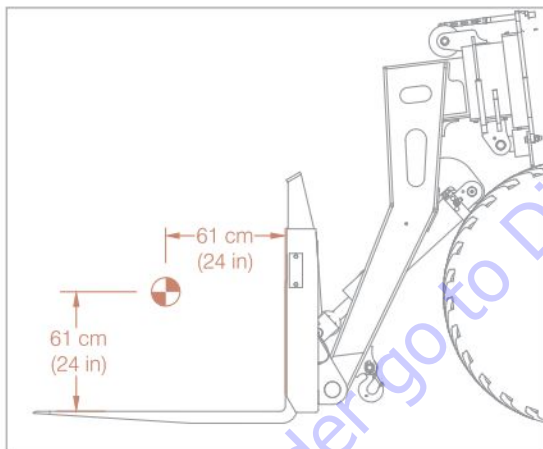

Figure 23 Load Center

5.7-1 Picking up a Load

1. Move the direction control lever to neutral and press the park brake switch (P) to on position.
2. Ensure the forks are as far apart as possible for the width of the load. This increases the stability of the load and the lift.
3. Approach load slowly with forks straight ahead and perpendicular to the load.
4. Insert forks under the load; making sure not to extend forks past the load so that any loads or equipment behind the load being lifted are not damaged, then raise it 13 cm to 25.4 cm (5 to 10 in).

5. Tilt forks backwards and fully retract boom.
6. Check telehandler stability before transporting the load.

NOTE

If the forks are longer than the load, move the forks under the load so that the tips of the forks do not extend beyond the load. Lift the load from the surface. Move backward a few centimeters (inches), then lower the load onto the surface and move forward to engage the load against the carriage. Tilt the forks backward just far enough to lift the load from the surface. When the boom is raised from the surface level, the tips of the forks move in an arc.

5.7-2 Transporting a Load

WARNING

When transporting a load, always travel according to jobsite and weather conditions.

1. Travel with caution to the placement site with the load kept as low to the ground as possible and the attachment centered to the sub-carriage. For specific attachment uses, refer to [Section 3.6](#).
2. Keep load against carriage and forks tilted backward. This position keeps the load on the forks and provides better forward and side stability.
3. Apply brakes smoothly to bring telehandler to a complete stop before pressing the park brake switch (P) to on position.

5.7-3 Placing a Load

1. Move the direction control lever to neutral and press the park brake switch (P) to on position.
2. Extend boom to the desired reach and tilt forks forward in a horizontal position.
3. Place load in a horizontal position then lower boom until load is completely off the forks. Do not apply downward force with the forks.
4. Free the forks gradually by lowering and retracting the boom alternately.
5. When forks are clear of the load, fully retract the boom.
6. Return to transport position.

5.8 Handling Loads at Variable Heights

WARNING

- Handle only loads within the rated capacity as shown on the capacity charts mounted on the telehandler.
- Ensure the capacity chart used corresponds to the attachment fitted to the telehandler.
- Use only manufacturer's approved attachments. The use of non-approved attachments may cause telehandler instability and tip-over, which may result in death or severe injury to operators or bystanders.
- Ensure that the load center for the load is at or within 61 cm (24 in) of forks (refer to *Figure 23*).
- Use a spotter when possible to assist in handling the load (refer to *Section 1.3*).

5.8-1 Picking up a Load

1. Move direction control lever to neutral and press the park brake switch (P) to on position.
2. Check that telehandler is level using the level indicator.
3. Ensure the forks are as far apart as possible for the width of the load. This increases the stability of the load and the lift.
4. Approach load slowly, raise and extend the boom until the forks are perpendicular to the load.
5. Extend and lower the boom to insert the forks under load; making sure not to extend forks past the load so that any loads or equipment behind the load being lifted are not damaged, then raise it 12.7 cm to 25.4 cm (5 to 10 in).
6. Tilt forks backwards. Fully retract the boom then check telehandler stability before transporting the load (refer to *Section 5.7-2*).

5.8-2 Placing a Load

1. Move direction control lever to neutral and press the park brake switch (P) to on position.
2. Raise and extend boom until the load is perpendicular over placement point.

3. Place the load in a horizontal position and lower boom until the load is completely off the forks. Do not apply downward force with the forks.
4. Free the forks gradually by lowering and retracting the boom alternately.
5. When forks are clear of the load, fully retract the boom then return to transport position.

5.9 Parking and Shutting Down the Telehandler

CAUTION

Operator should observe the following when parking the telehandler.

- Avoid parking on slopes or near excavation, ditches or soft fills. If parking on slopes cannot be avoided, ensure frame is leveled and telehandler is positioned at a right angle across the slope.
- Avoid parking on roads or highways. If it cannot be avoided, ensure to display warning flags during the day and flares or flashing lights at night.

1. Position telehandler on a firm and level surface.

WARNING

Engage the park brake switch (P) before exiting the operator's cab.

2. Bring telehandler to a full stop.
3. With foot on service brake, press the park brake switch (P) to on position.
4. Move direction control lever to neutral position.
5. Release service brake and ensure machine does not roll.
6. Retract boom fully and position attachment on ground.
7. Allow engine to idle for 3 to 5 minutes.
8. Shut off engine and remove key.

WARNING

Ensure that you maintain three points of contact to mount/dismount the cab.

9. Dismount from telehandler.
10. Chock or block wheels to prevent telehandler from rolling.

5.10 DEUTZ Engine Data Display Module

The DEUTZ Display combines a graphic LCD display with five function buttons at the bottom of the screen (see *Figure 24*).

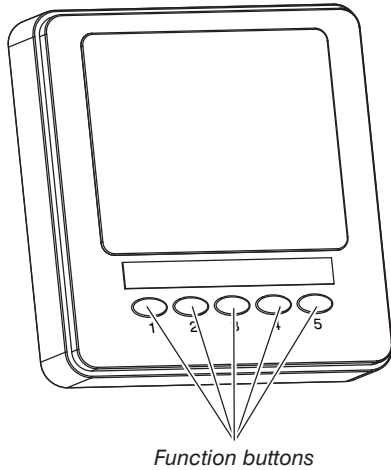

Figure 24 Engine Data Display Module

5.10-1 Function Buttons

1. Pressing any button calls up the main buttons menu.
2. The positioning of the symbols above the relevant button allows the button function to be changed. The buttons correspond to the following functions:

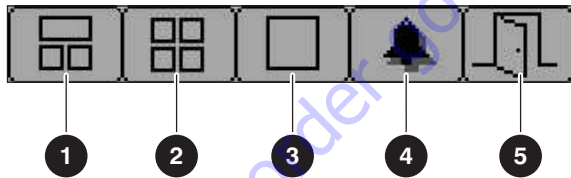

Figure 25 Main Buttons Menu

- ① Engine Main Display
- ② Quad Display
- ③ Graphic Display
- ④ Error Messages
- ⑤ Exit

5.10-2 Contrast & Illumination Settings

1. Pressing **button 5** calls up the Contrast and Illumination menu when the menu symbols are

not displayed.

2. Adjust illumination using **button 1** for dimming or **button 2** for brightening the illumination.

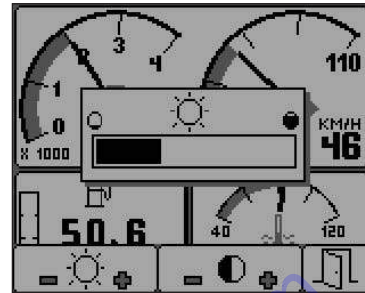

Figure 26 Setting Screen Illumination

3. Adjust contrast by using **button 3** to decrease contrast and **button 4** to increase the contrast.

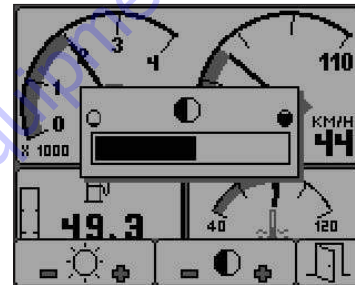

Figure 27 Setting Screen Contrast

5.10-3 Engine Main Display

1. To show the engine main display, press any button to display the menu symbols, then press **button 1**.

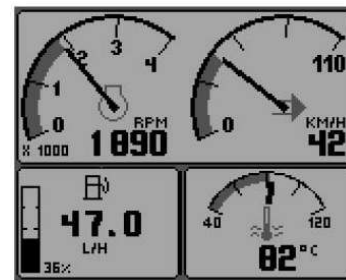

Figure 28 Main Screen

2. The top window shows two scales: engine RPM and coolant level. The bottom left window shows the instantaneous fuel consumption while the right window shows the coolant temperature.

- Pressing **button 1** repeatedly will display various parameters such as; fuel consumption, average fuel consumption per route and operating hours per route travelled.

5.10-4 Quad Display

This display gives the user rapid access to four displays, each of which can show four instruments. Information can be shown in either digital or analog format.

- To select the quad display, press any button to display the menu symbols and then press **button 2**.

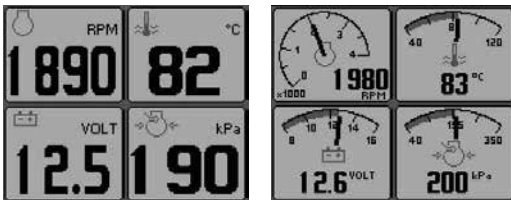

Figure 29 Digital and Analog Quad Display

- The screens are displayed in sequence as a response to repeated pressing of **button 2**.
- Using the setting mode allows the user to set every instrument shown on the screen in order to be able to display various engine parameters from a long list.
- The setting mode is activated by pressing **button 5** when the menu is visible.
- The menu as shown in the figure below appears in the setting mode.

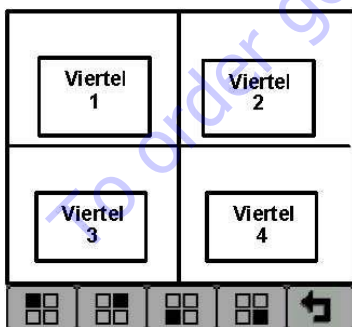

Figure 30 Quad Display Settings

- Pressing **button 1** causes the top left display to roam through all available engine parameters. Pressing **button 2** roams through the top right display, etc.
- Quit the display by pressing **button 5**.

5.10-5 Graphic Display

The graphic display shows data trends in a large window and functions like an analog data recorder.

- To access the graphic display, press any button to display the main menu symbols, then press **button 3**.

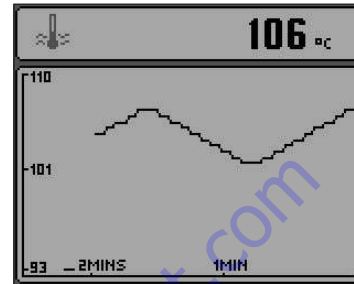

Figure 31 Example of Graphic Display

Showing Coolant Temperature

- The required time grid can be set in the configuration menu from 2, 10 or 30 minutes to 1, 2, 4 or 8 hours.
- The maximum and minimum values of the Y-axis that define the range of the display are automatically adapted to give an optimal overview of the visible data.
- The data to be displayed can be selected by repeatedly pressing **button 3** when in graphic display mode.

5.10-6 Error Messages

If a new error message is received, the DEUTZ display will beep and a flashing popup window will open with the latest error messages and details.

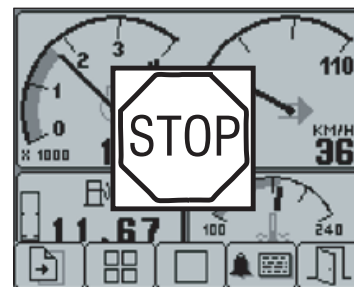

Figure 32 Error Message Popup

- The error list is displayed by pressing any button. The errors that have been read appear in black text on a grey background. New messages that have not been read appear as emphasized grey text on a black background.

The most recent error is automatically displayed when the error list is called up.

- If the list is longer than the screen section, you can browse through the list using **buttons 1** and **2**.



Figure 33 Error Message

- The error list cannot be exited until all alarms have been acknowledged by pressing **button 3**. The error list display can be viewed at any time by pressing **button 4**.

5.10-7 Display Configuration

Configuration mode allows the user to set various operating parameters and modes of the DEUTZ Display. This includes setting the units (metric or US customary), measuring range settings or engine service intervals.

- The configuration menu can be called up by pressing and holding down **button 5** for at least 3 seconds.
- To secure the configuration display, the display prompts you to enter a PIN number before accessing the configuration menu. The default PIN is 1111.

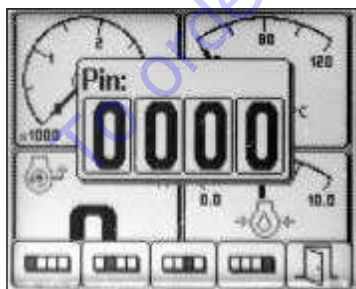

Figure 34 PIN Pop-up

- Press **buttons 1, 2, 3, 4**, and finally press **button 5** to confirm the information.



Figure 35 PIN Number Entry

- The configuration menu is displayed once the pin number has been entered.
- Buttons 1** and **2** allow scrolling up and down the menu, while **button 4** calls up the highlighted selection.
- Use **button 5** to exit configuration menu or browse back a level.



NOTE

Refer to the service manual of this telehandler for a list of error codes.

5.11 Use of the Capacity Charts

Capacity charts are located in the operator’s cab, and used to determine the maximum load capacity of the telehandler when using different attachment combinations.

Each attachment has its own capacity chart.

To properly use a particular capacity chart, the operator must first determine the following:

1. Ensure the capacity chart is for the specific telehandler model and attachment.
2. Determine the weight of the load to be lifted.
3. Ensure that the load center for the load is at or within the load center specified for the attachment.
4. Determine the height where the load is to be picked or placed.
5. Determine the reach where the load is to be picked or placed.

NOTE

The user shall consider that changes in load dimension may affect rough terrain forklift truck capacity.

5.11-1 Maximum Load Capacity

The maximum load capacity is determined by finding the intersection of the values for height and reach on the capacity chart. The weight of the load to be lifted must be equal to or less than the determined maximum load capacity.

NOTE

If the intersection occurs on a bold line separating the capacity regions, the smaller of the two capacity values must be used.

WARNING

When handling loads, ensure that boom extension indicator and boom angle indicator remain within previously determined/calculated capacity zone.

Some examples of how to determine the maximum load capacity and safe lifting weights are given in Section 5.11-2.



Attachment Reference Number

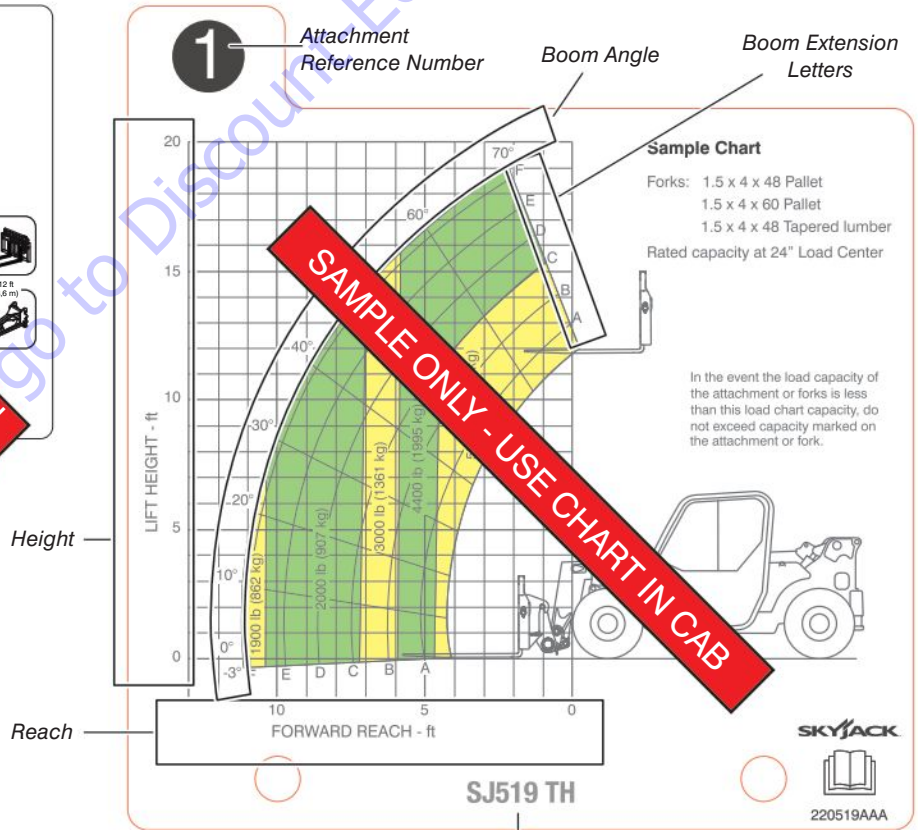

Telehandler Model

NOTE

This is a sample capacity chart only! DO NOT use this capacity chart. Use chart inside cab.

5.11-2 Examples on Reading the Capacity Chart

The following scenarios show various conditions the operator may encounter:

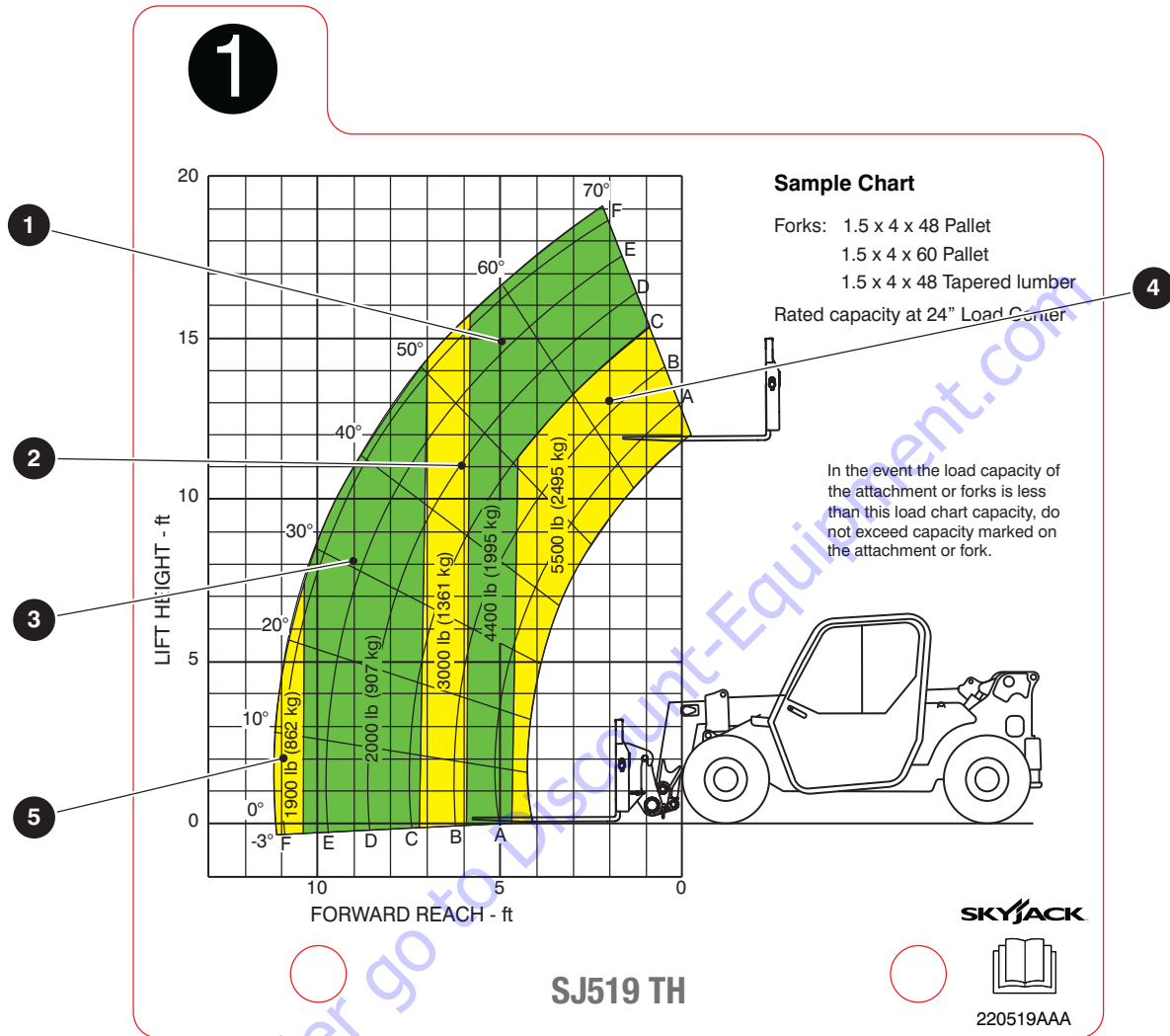

SAMPLE ONLY - USE CHART IN CAB

Examples	Load Weight	Forward Reach	Lift Height	Boom Angle	Boom	Capacity	OK to Lift
1	1,134 kg (2,500 lb)	1.52 m (5 ft)	4.57 m (5 ft)	56°	E	1,980.8 kg (4,400 lb)	YES
2	1,225 kg (2,700 lb)	1.83 m (6 ft)	3.35 m (11 ft)	45°	D	1,360.8 kg (3,000 lb)	YES
3	997.9 kg (2,200 lb)	2.74 m (9 ft)	2.43 m (8 ft)	31°	D	907.2 kg (2,000 lb)	NO
4	2,267.96 kg (5,000 lb)	0.6 m (2 ft)	3.96 m (13 ft)	63°	B	2,494.75kg (5,500 lb)	YES
5	2,041.61 kg (4,500 lb)	3.35 m (11 ft)	0.6 m (2 ft)	5°	E	861.82 kg (1,900 lb)	NO

5.12 Attachment Installation and Adjustment

Several attachments aside from the common carriage/fork combination are available for use with the telehandler. Installation and operation of other approved attachments are covered in this section.

5.12-1 Installing Attachments Using the Quick Attach Feature

1. Ensure the attachment is positioned on level ground.

WARNING

Always ensure transmission is in neutral and the park brake switch (P) is engaged before leaving the cab to prevent the telehandler from rolling. Failure to do so may result in death or serious injury to operators and bystanders.

2. Remove the lynch pins from the quick attach pins on both sides of the apron. Allow the quick attach and lynch pins to hang freely from their tethers.
3. Approach the attachment perpendicularly. Position the upper apron bar below the coupling points on the frame of the attachment.
4. Raise and tilt the apron backwards to engage the attachment. Lift the attachment clear of the ground. Ensure the quick attach pin holes are aligned.
5. Insert the quick attach pins so the lynch pins are oriented on the outside of the apron. Secure quick attach pins with lynch pins.
6. If necessary, connect auxiliary hydraulic hoses to the attachment.

WARNING

Visually check that the attachment is correctly coupled and secured to the boom before operating the telehandler.

5.12-2 Removing Attachments Using the Quick Attach Feature

1. Position the boom with the attachment just above ground level.

WARNING

Always ensure transmission is in neutral and the park brake switch (P) is engaged before leaving the cab to prevent the telehandler from rolling. Failure to do so may result in death or serious injury to operators and bystanders.

2. Disconnect any auxiliary hydraulic hoses.
3. Remove the lynch pins then the quick attach pins securing the attachment to the apron. Allow pins to hang from their tethers.
4. Lower and tilt the attachment forward until the attachment is resting on the ground.
5. Retract the boom to clear the upper apron bar from the frame of the attachment.
6. Replace quick attach pins with lynch pins oriented on the outside of the apron. Ensure lynch pins are in place and quick connect pins secured.

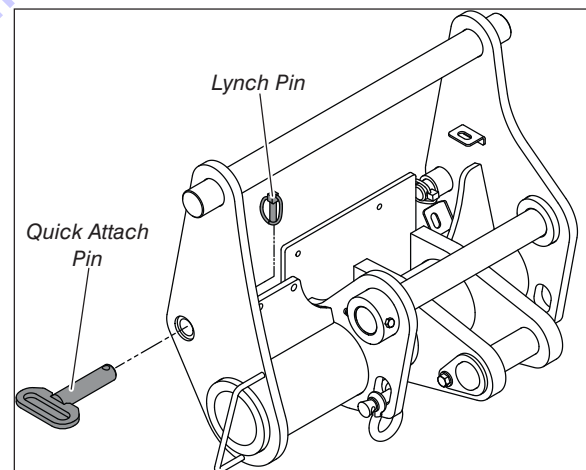

Figure 36 Quick Attach Feature

5.12-3 Installing Attachments Using the Hydraulic Quick Attach Feature (If Equipped)



NOTE

If necessary, connect auxiliary hydraulic hoses of the attachment.

1. Ensure the attachment is positioned on level ground.
2. Ensure hydraulic quick attach switch and the quick attach pins on the apron are in the retracted position.
3. Approach the attachment perpendicularly. Position the upper apron bar below the coupling points on the frame of the attachment.
4. Raise and tilt the apron backwards to engage the attachment. Lift the attachment clear of the ground. Ensure the quick attach pin holes are aligned.
5. Using the hydraulic quick attach switch, deploy the quick attach pins. The pins extend and secure the attachment to the apron.

WARNING

Always ensure transmission is in neutral and the park brake switch (P) is engaged before leaving the cab to prevent the telehandler from rolling. Failure to do so may result in death or serious injury to operators and bystanders.

WARNING

Visually check that the attachment is correctly coupled and secured to the boom before operating the telehandler.

5.12-4 Removing Attachments Using the Hydraulic Quick Attach Feature (If Equipped)

1. Position the boom with the attachment just above ground level.

WARNING

Always ensure transmission is in neutral and the park brake switch (P) is engaged before leaving the cab to prevent the telehandler from rolling. Failure to do so may result in death or serious injury to operators and bystanders.

2. Disconnect any auxiliary hydraulic hoses.
3. Using the hydraulic quick attach switch, retract the quick attach pins.
4. Lower and tilt the attachment forward until the attachment is resting on the ground.
5. Retract the boom to clear the upper apron bar from the frame of the attachment.

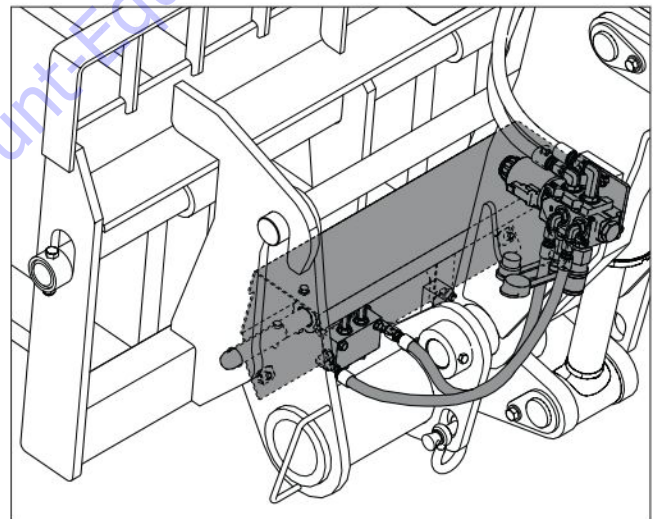

Figure 37 Hydraulic Quick Attach Feature

5.12-5 Adjusting Forks

Adjust the location of both forks manually to suit pallet pocket spacing as follows:

1. Raise the boom until fork eye is approximately shoulder high.
2. Tilt the attachment forward until the fork pivots on the bar, and no longer resting on the carriage's bottom rail (see *Figure 38*). This prevents binding on the bar, thus aiding its repositioning.

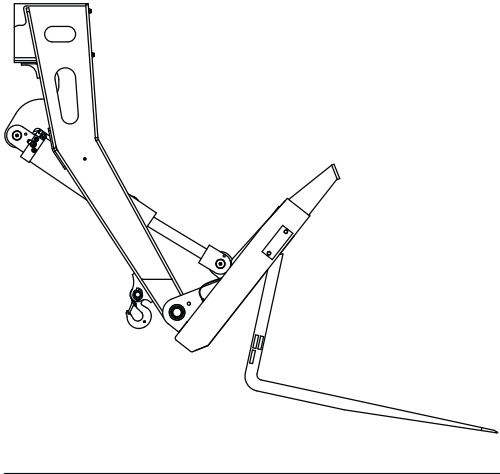

Figure 38 Fork Pivoting on the Bar

CAUTION

Be careful not to pinch fingers between the fork and any portion of the attachment.

3. Grasping the fork near its eye, push the fork along the bar until it is in the desired position.
4. Before traveling, make sure the forks are centered with the carriage and are equally spaced.

5.12-6 Changing Forks

The carriage/fork combination is the most frequently used combination. Different loads may require changing forks with different ratings.

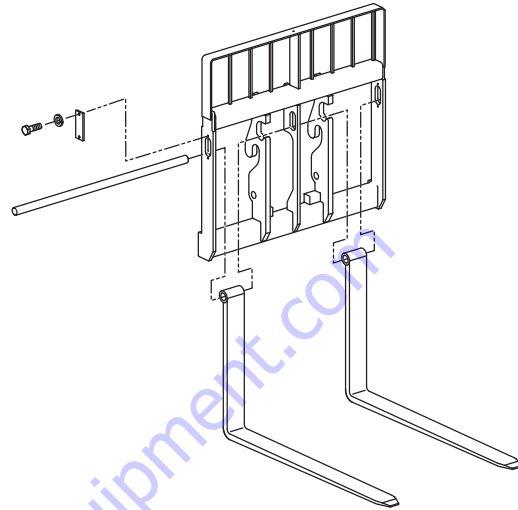

Figure 39 Changing Forks

1. Lower the boom with fork contacting the ground until approximately half of the fork float is used up.
2. Remove fork bar collars from fork bar.
3. Draw the bar out of the fork eye, being careful that the fork does not fall over, causing possible injury (see *Figure 39*).

CAUTION

Ensure that the forks are properly secured during the removal and installation process. Failure to do so may result in serious injury.

4. Reverse steps 1 to 3 to install the replacement fork.

5.13 Slinging Loads

⚠ WARNING

Sling loads from appropriate attachment, hook mounted to the shackle on the jib boom or a tilted fork ONLY.

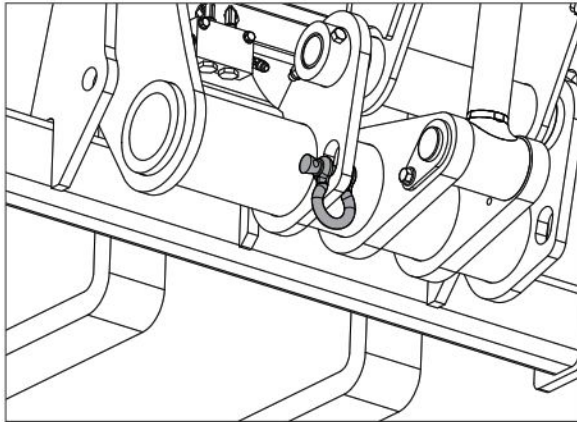

Figure 40 Lifting Shackle

1. Slinging of loads must only be performed following a complete risk assessment by a qualified person regarding the rigging and guiding of any such load.
2. The rated capacity of the unit and attachment at the sling position must not be exceeded. The sling must be in good repair and restrained from movement at all times.
3. Retract the boom as far as is practical during pick and carry operations.
4. Perform all boom and traveling operations slowly and smoothly to prevent the load from swinging. Avoid turning if possible.
5. Only lift the load vertically and never drag it horizontally.
6. Transport the load with the bottom of the load and the mast as low as possible.
7. Use guide lines to restrain load swing whenever possible.

5.14 Third-Party Attachments

Skyjack's Variable Reach Rough Terrain Forklifts (RTFLs), are designed to lift and/or handle industrial products by means of various attachments. Skyjack does not certify the design of third-party attachments. Skyjack does not assume any responsibility or liability for damages resulting from the use of third-party attachments on any of its TH/THS RTFLs.

It is permissible to install and utilize third-party attachments provided they do not elevate personnel, and the following conditions are met:

⚠ WARNING

Be sure to follow all conditions, regulations and instructions outlined below and all requirements of the local authorities. Failure to do so may result in death or serious injury.

- The combined mass of the attachment and load shall not exceed that of the RTFL load chart for the applicable load center. The rated capacity of the attachment shall not be exceeded.
- In addition to the RTFL operating instructions, all instructions provided by the manufacturer of the attachment must be followed and any additional requirements of local authorities should also be followed.
- Attachments shall be designed and constructed according to ANSI/ITSDF B56.6-2016 and CSA B335, including markings identifying the combined RTFL and attachment weight, and the RTFL capacity with the attachment at maximum elevation and load laterally centered.
- The attachment must be securely attached to the RTFL, per the attachment manufacturer's instructions.
- Prior to using the attachment on each shift, the RTFL operator must visually examine the attachment for structural integrity and perform the daily inspection and function tests on the RTFL. Any equipment defects must be repaired before the attachment or RTFL can be used.

Section 6 – Procedures

6.1 Refueling Procedure

6.1-1 Diesel Fuel

This section provides the operator with procedure on how to refuel telehandler with diesel fuel.

IMPORTANT

Before using your telehandler ensure there is enough fuel for expected use.

- Fill diesel tank with ultra low sulfur diesel only.
- Use extreme caution while refueling telehandler.
- Ensure that engine and all systems are turned off before refueling.
- Refuel the telehandler only in a well ventilated area away from open flame and other sources of ignition, authorized by your employer and supervisor.
- To minimize possible static electricity fires, ensure filler nozzle touches rim of filler opening to aid the dissipation of static electricity.
- Never try to start telehandler if you smell diesel.
- Be sure to follow all local, provincial/territorial/state and national regulations related to disposing of fluids and soiled rags, cloths, etc.

1. Ensure engine and all systems are turned off.
2. Open fuel cap.
3. Carefully pour diesel fuel into the tank, ensuring no spillage occurs.
4. Close and secure fuel cap.
5. Ensure there are no leaks in fuel system.
6. Wipe up any spilled fuel.
7. Dispose of rags in an approved container.

WARNING

Do not smoke in an area where telehandlers are stored or refueled.

IMPORTANT

The storage and handling of liquid fuels and liquefied petroleum gas fuel used in RTFL shall be in accordance with NFPA 505, NFPA 30 and NFPA 58 as applicable.

6.2 Lifting SJ519 TH

Four lifting points are located on the top of the frame: two at the front and two at the rear.

Follow these guidelines to lift the machine:

1. Fully retract and lower boom.
2. Turn ignition switch to the off  position. Remove the key.
3. Block the rear axle by placing wood between the frame and the axle.

WARNING

Only qualified rigger shall operate machinery during lifting.

Use rigging with load capacity sufficient to withstand telehandler weight. Refer to the serial plate of the telehandler for specific weight.

4. Properly adjust rigging to ensure telehandler remains level during lifting. See Center of gravity location.

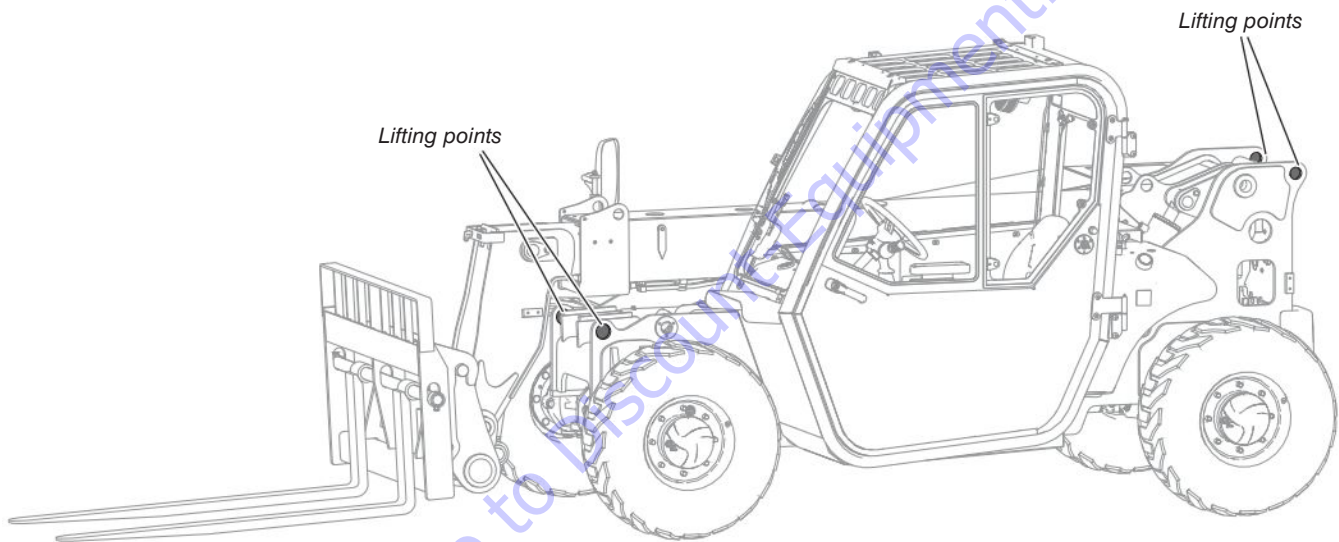

Figure 41 Lifting point locations

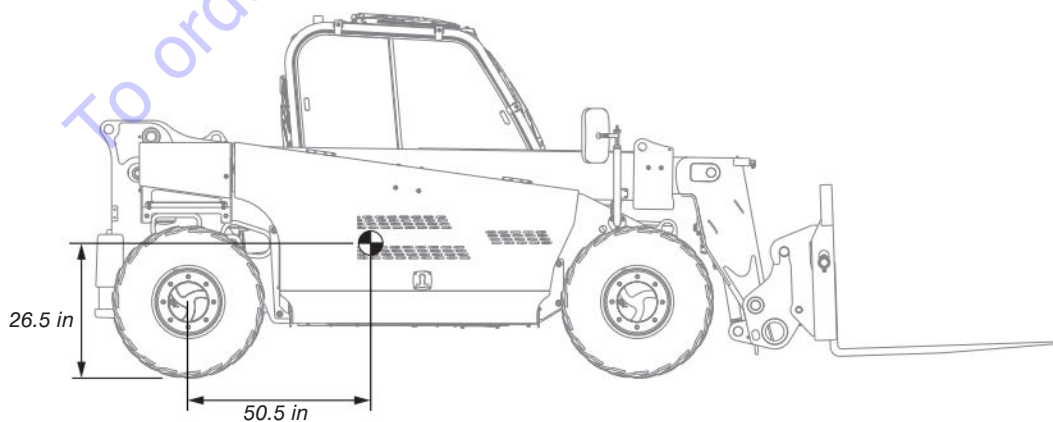

Figure 42 Center of gravity

6.3 Loading, Tie-downs and Transporting

Know all national, state/provincial and local rules which apply to transporting of telehandlers.

Only qualified personnel shall operate machinery during loading and transporting.

Be sure vehicle capacity and loading equipment hoists, chains, straps, etc., are sufficient to withstand maximum telehandler weight.

The transport vehicle must be parked on a level surface and must be secured to prevent rolling while telehandler is being loaded or unloaded.

IMPORTANT

All turbo-engine air cleaner and exhaust must be sealed during transport.

1. Ensure telehandler is level prior to loading.
2. Fully lower and retract boom.
3. Ensure ramps are correctly positioned.

4. Using a spotter, carefully drive telehandler onto the transporting vehicle.
5. Once telehandler is loaded, apply parking brake and rest the attachment flat on the vehicle.
6. Move all controls to neutral position.
7. Turn key switch to off position and remove key before transporting.
8. Chock telehandler wheels (if necessary).
9. Remove all loose items.
10. Anchor down telehandler to transport surface using tie-down points (see [Figure 43](#)) and secure the forks to the platform using sufficient straps.

WARNING

Inspect telehandler for loose or unsecured items.

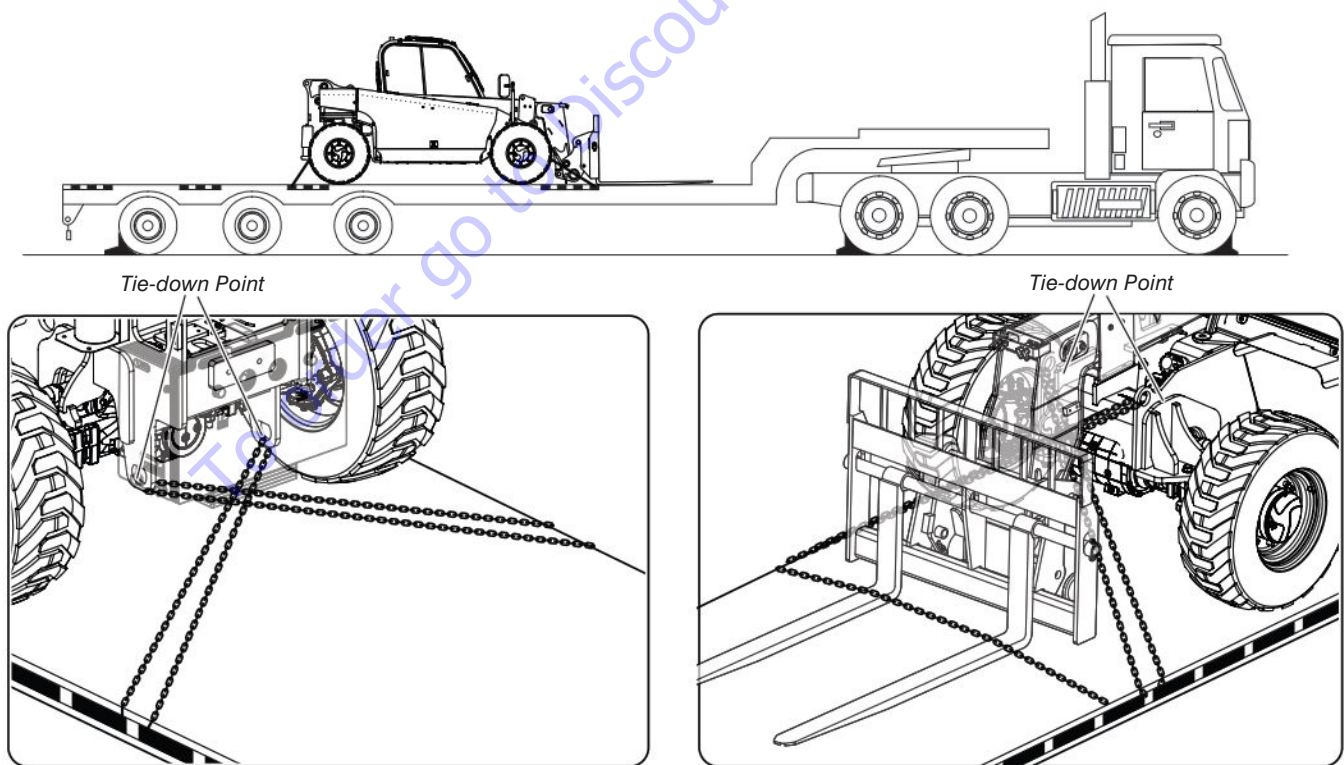

Figure 43 Tie-down points

6.4 Towing the Telehandler

IMPORTANT

- Use this procedure only to remove telehandler from mud or other places where it cannot move under its own power. When possible, repair telehandler on site.
 - Always chock wheels of the disabled telehandler to prevent accidental movement while preparing for towing. This is especially important if the failure occurs on an incline.
 - Before towing, ensure there are no obstructions around or between telehandler and towing vehicle.
 - The spotter must maintain a safe distance and must always be visible to the operator inside telehandler's cab.
 - Ensure the towing vehicle, chains, tow bar, etc., are suitable for the job. The telehandler weight is stamped on the serial number nameplate (see [Section 1.5](#)).
1. Lower or raise boom enough so that front lifting points are fully accessible.
 2. Carefully fasten tow chains to lifting points on the front of the telehandler frame.
 3. Disconnect the drive shaft from the rear and front axles.
 4. Remove chocks from wheels.
 5. Start towing the telehandler.
 6. Move telehandler to a compact level surface.
 7. Install drive shaft in both front and rear axles.
 8. Apply parking brake.

9. Chock or block wheels to prevent telehandler from rolling.

WARNING

Poor traction can cause telehandler or towing vehicle to slide. Grades can require additional distance to stop the telehandler. Be careful if traction conditions are poor or the machine is on an incline.

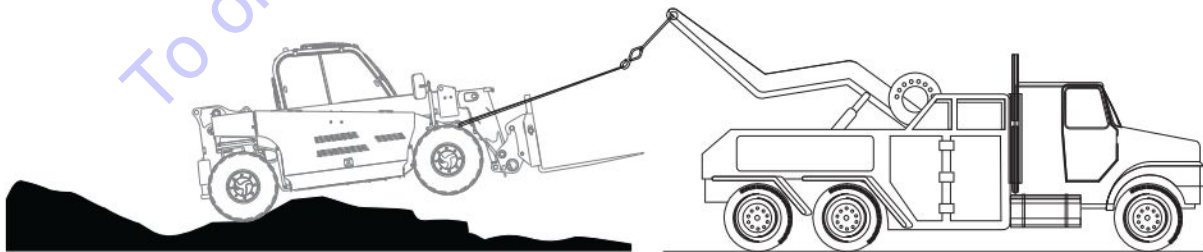

Figure 44 Towing the telehandler from front lifting points

6.5 Using the Telehandler as a Tow Vehicle

⚠ WARNING

Do not exceed rated towing capacity. Failure to do so may result in death or serious injury. See [Table 7.2](#).

⚠ WARNING

Maximum towing capacity of the telehandler is determined with **NO LOAD ON BOOM**. Never attempt to operate the boom or lift any load while telehandler is being utilized as a tow vehicle.

6.5-1 Rear Hitch

The **Rear Hitch 1** utilizes the telehandler as a towing vehicle and is located at the rear of the telehandler as shown in [Figure 45](#) below.

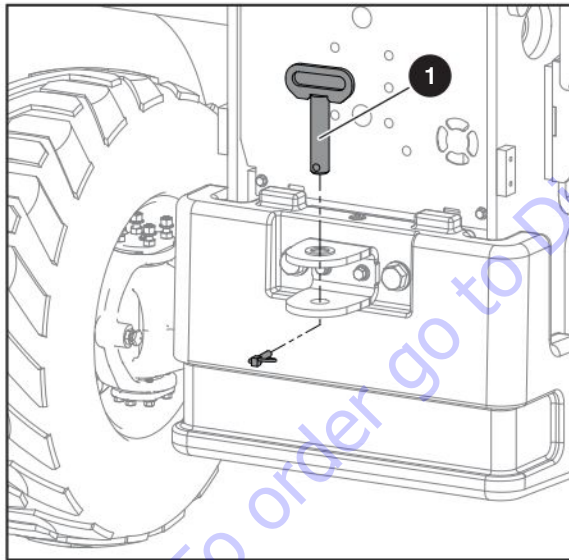

Figure 45 Rear Hitch

Section 7 – Specifications

To order go to Discount-Equipment.com

Table 7.1 Standard and Optional Equipment

MODEL	SJ519 TH
Standard Equipment	
122 cm (48 in) Standard Carriage	*
Air Filled Tires	*
Diesel Engine	*
Four-wheel drive	*
Lifting Hook	*
Open Operator's Cab	*
Operator horn	*
Reverse/Backup Alarm	*
Spring-applied Hydraulically Released Parking Brake	*
Single-Speed Hydrostatic Transmisson	*
Three-Mode Steering	*
Rear Hitch	*
Optional Equipment	
Tilt Steering	*
0.38 m ³ (0.50 Cu. Yd.) 167.64 cm (66 in) Bucket Loader Attachment	*
183 cm (6 ft) Truss Boom Attachment	*
Skid Steer Adaptor Attachment	*
122 cm (48 in) Side-Tilt Fork Carriage	*
122 cm (48 in) Side Shift Fork Carriage	*
Back-up Sensor/ Back-up Camera and Sensor	*
Enclosed Operator's Cab	*
Enclosed Operator's Cab with A/C	*
Fire Extinguisher	*
Flashing Beacon	*
Foam Filled Tires	*
Solid Black Rubber Tires	*
Solid Non Marking Tires	*
Air / Foam Non Marking Tires	*
Air / Foam Wearmaster Tires	*
Four-Wheel Fenders	*
Positive Air Shut-off System	*
Road/Work/Boom Lights	*
Speed Limiter Control	*
Service Convenience Package	*
Partially Enclosed Cab	*
Hydraulic Quick Coupler	*

1691AA

Table 7.2 Specifications and Features

MODEL		SJ519 TH
Standard Engine		
Type	Deutz TCD 2.2 L T4	
Cylinders	3	
Horsepower @ 2600 RPM	74 HP	
Capacity	2.2 L	
Torque @ 1600 RPM	280 N•m (206.5 lbf•ft)	
Idle Speed*	1200 rpm	
Fuel type	Diesel	
Transmission		
Hydrostatic	Speed forward / Reverse	Hydrostatic (Variable)
Travel Speed		
Hydrostatic	23 km/h (14.5 mph)	
Electrical		
Negative ground	12 Volts	
Alternator	120 Amps	
Battery	925 CCA	
Backup Alarm	107 DBA	
Dimensions		
Wheelbase	245.11 cm (8 ft 0.5 in)	
Overall width	182.88 cm (6 ft)	
Overall height (stowed)	193.04 cm (6 ft 4 in)	
Overall length (stowed, less forks)	408.94 cm (13 ft 5 in)	
Ground clearance	24.13 cm (9.5 in)	
Maximum weight without attachment	10,255 lb	
Turn radius (inside) (4WS)	134.62 cm (53 in)	
Turn radius (outside) (4WS)	317.50 cm (125 in)	
Boom		
Number of sections	2	
Maximum lift height	5.82 m (19 ft 1 in)	
Maximum forward reach	3.38 m (11 ft 1 in)	
Standard Forks (Standard Tapered Forks)	4 cm x 10 cm x 122 cm (1.57 in x 3.94 in x 48 in)	
Carriage rollback @ Maximum Boom Angle (Top)	88°	
Carriage forward tilt @ Maximum Boom Angle (Bottom)	40°	
Towing Capacity		
Towing Weight (MAX)	2,268 kg (5,000 lb)	
Towing Tongue Weight (MAX)	340 kg (750 lb)	

* Engine Idle Speed is measured with 5% droop when in gear.

1692AA

Table 7.3 Tire/Wheel Specifications

Model SJ519 TH					
	FILL	Size	Pressure	"Ply Rating"	"Wheel Nuts Torque"
BLACKSTONE OTR	AIR	26.7 cm x 44.5 cm (12.00 in x 16.5 in)	552 Kpa (80 psi)	12	" 372.85 N•m (275 lbf•ft)"
	FOAM		N/A		
	NON MARKING AIR		552 Kpa (80 psi)		
	NON MARKING FOAM		N/A		
WEARMASTER OTR	AIR		552 Kpa (80 psi)		
	FOAM		N/A		
SOLIDBOSS	BLACK RUBBER	83.8 cm x 30.5 cm (33 in x 12 in)	N/A	20	
	NON MARKING		N/A		

1694AA

To order go to Discount-Equipment.com

Table 7.4 Recommended Fluids/Lubrications

Model SJ519 TH		
Engine		
Fuel Type	Ultra Low Sulfur Diesel (EN 590, ASTM D975) or Biodiesel B20	
Fuel Tank Capacity	57 L (15.1 gal)	
Recommended Oil Type	SAE 15W40	
Engine Oil Capacity	8.5 L (9 Quart)	
Coolant Type (Standard)	COOLANT-ANTIFREEZE 50/50 PREMIX *	
Coolant Type (Cold Weather Option)	COOLANT-ANTIFREEZE 60/40 PREMIX *	
Coolant Tank Capacity	12 L (3.2 gal)	
Transmission		
Hydrostatic	Oil Type	ATF Dexron 3
Axles		
Differential	API GL5 LS	
Front Gear Box Capacity	0.7 L (0.74 Quart)	
Front Central House Capacity	4.0 L (4.2 Quart)	
Rear Central House Capacity		
Front Wheel Hub Capacity	0.9 + 0.9 L (0.95 + 0.95 Quart)	
Rear Wheel Hub Capacity	0.9 + 0.9 L (0.95 + 0.95 Quart)	
Hydraulic Oil		
Standard Factory Fill	ATF Dexron 3	
Type	Multipurpose ATF	
Hydraulic Tank Capacity	70 L (18.5 gal)	
Grease Points		
Type	EP2 Grease	

* Refer to engine manufacturer's manual

1693AA

⚠ WARNING

Do not mix hydraulic oil of different types or use oils of types other than those originally supplied with this equipment. Doing so can severely damage hydraulic components. A full hydraulic oil system flush must be performed prior to adding a new type of hydraulic oil. Consult Skyjack service department.

Section 8 – Labels

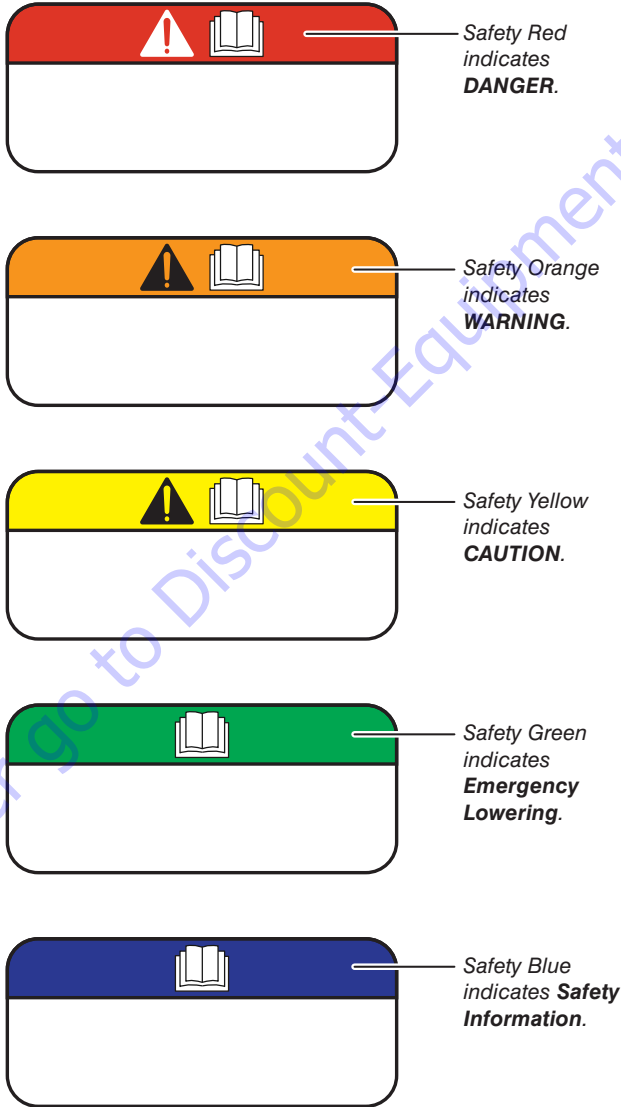
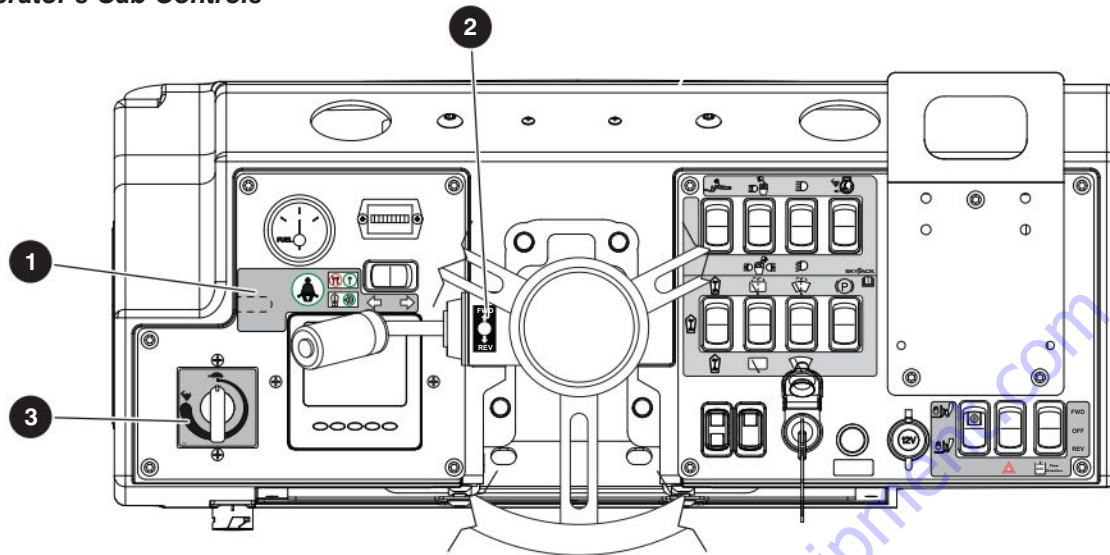

Figure 46 Label legend

8.1 Model SJ519 TH

Operator's Cab Controls



Description

Label Pictorial

1 Left Side Dash Panel

Turn Signals Switch (if equipped)

- Select ← to signal left.
- Select → to signal right.

Always wear seat belt .

Absolutely no riders .

This vehicle is equipped with a backup alarm sound .



2 Direction Control Lever

Transmission gear selector



3 Hydrostatic Pump Speed Control

Adjust knob to control the speed of the hydrostatic pump

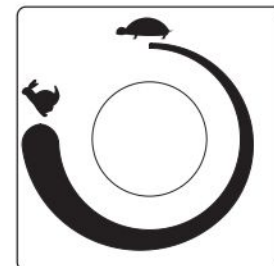

Operator’s Cab Controls (continued)

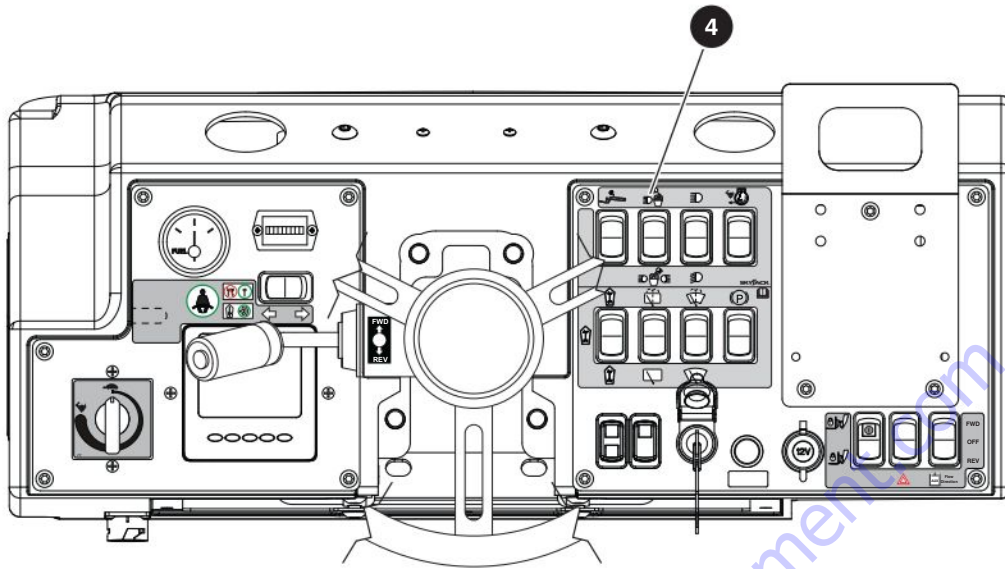

Description



Label Pictorial

4 Right Side Dash Panel



Boom Lights Switch (if equipped)

- Select  to turn on boom lights.

Front and Rear Work Lights Switch (if equipped)

- Select  to turn on front work lights.
- Select  to turn on front and rear work lights.



High/Low Headlights and Taillights Switch (if equipped)

- Select  to turn on high beam headlights and tail lights.
- Select  to turn on low beam headlights and tail lights.

Positive Air Shutoff Switch (if equipped)

- Select  to trigger the positive air shutoff valve.

Steering Mode Switch

- Select  for four-wheel steering.
- Select  for front steering.
- Select  for crab steering.

Rear Windshield Washer/Wiper Switch

- Select to  turn on. Select  to turn on wiper.

Front & Top Windshield Wiper Switch

- Select  to turn on. Select  to turn on wiper.

Park Brake Switch

- Select  to engage park brake.

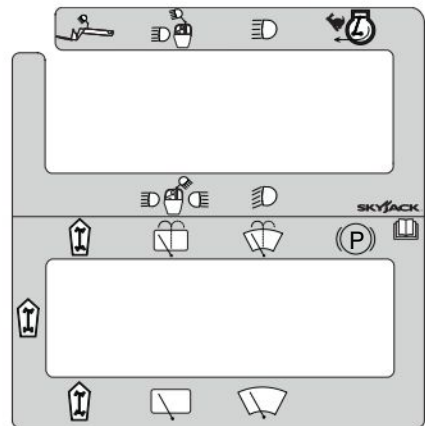

Operator's Cab Controls (continued)

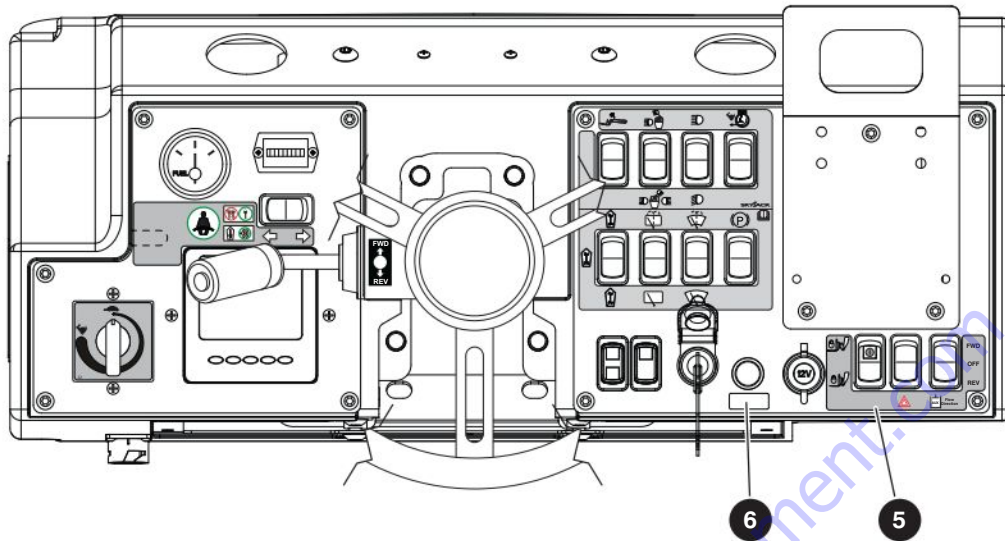

Description

Label Pictorial

5 Right Side Dash Panel

Hydraulic Quick Attach Switch (If Equipped)

- Select to activate the hydraulic quick attach function.
- Select to deactivate the hydraulic quick attach function.

Hazard Warning Light Switch (if equipped) .

Attachment Hydraulic Flow Direction .



6 Horn

Horn label



Operator’s Cab Controls (continued)

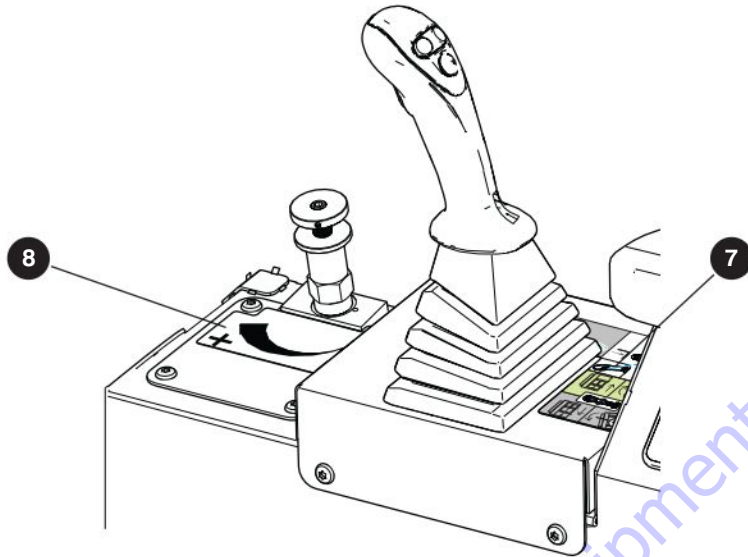

Description

Label Pictorial

7 Multi-functional Joystick

The multi-function single controls boom operation, fork tilt, and auxiliary functions.

- Move joystick forward or backward to raise or lower the boom.
- Move joystick right or left to extend or retract the boom.
- Press and hold middle button and move joystick forward to tilt attachment forward.
- Press and hold middle button and move joystick rearward to tilt attachment backward.
- Use optional attachment function switches to control the auxiliary functions of optional attachments.
- Press and hold the trigger button and move joystick left to lock the attachment with the hydraulic quick attach (If Equipped).
- Press and hold the trigger button and move joystick right to unlock the attachment with the hydraulic quick attach (If Equipped).

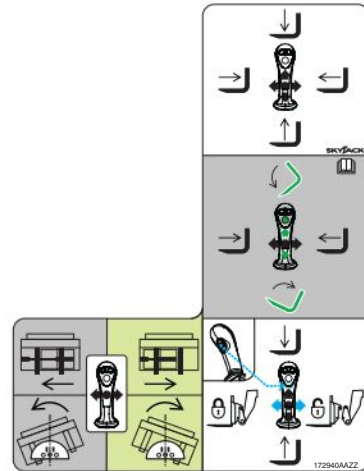

6 Attachment Hydraulic Flow Control

- Increase the flow of hydraulic fluid through the attachment by turning the Attachment Hydraulic Flow Control clockwise.
- Decrease the flow by turning it counterclockwise.



Operator's Cab

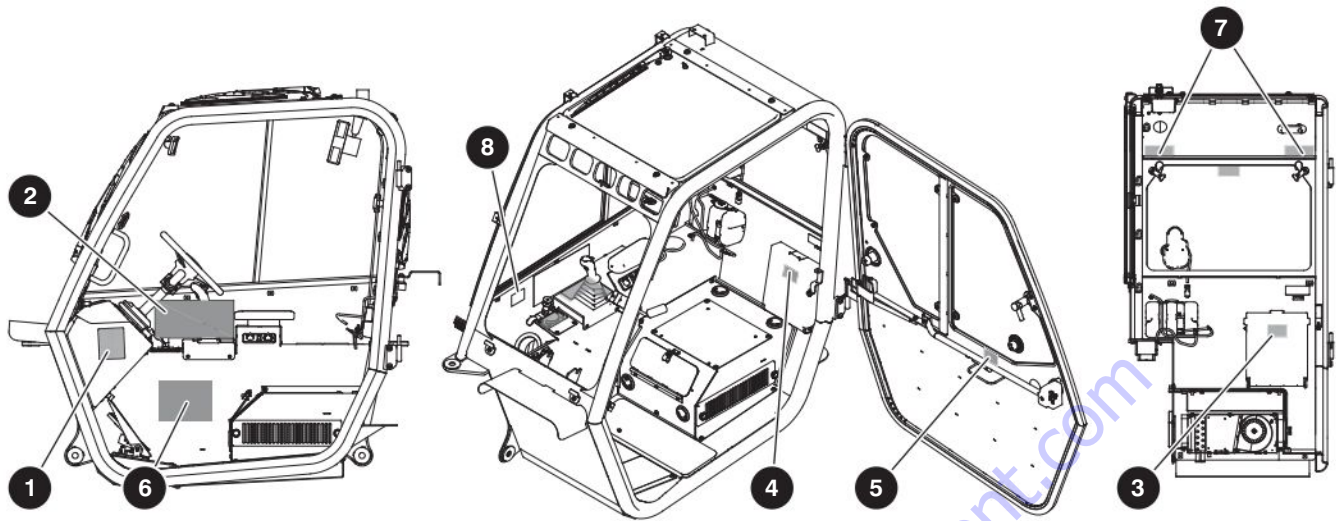

Description	Label Pictorial
<p>1 Transportation Reminder Ensure engine air cleaner, and exhaust are sealed during transportation.</p>	
<p>2 Hazard Identification Read and understand outlined risks associated with this telehandler prior to operation.</p>	
<p>3 Windshield Washer Fluid Container Windshield Washer fluid</p>	
<p>4 Manual Storage Box Indicates location of operating manual and other important documentation.</p>	
<p>5 Open Door (If Equipped) Squeeze to open cab door.</p>	
<p>6 Daily & Weekly Maintenance Chart Grease points and lubrication intervals chart</p>	
<p>7 Emergency Exit Procedure</p>	
<p>8 Warning - California Proposition 65 Cancer and Reproductive Harm- https://www.p65warnings.ca.gov/.</p>	

Left Side

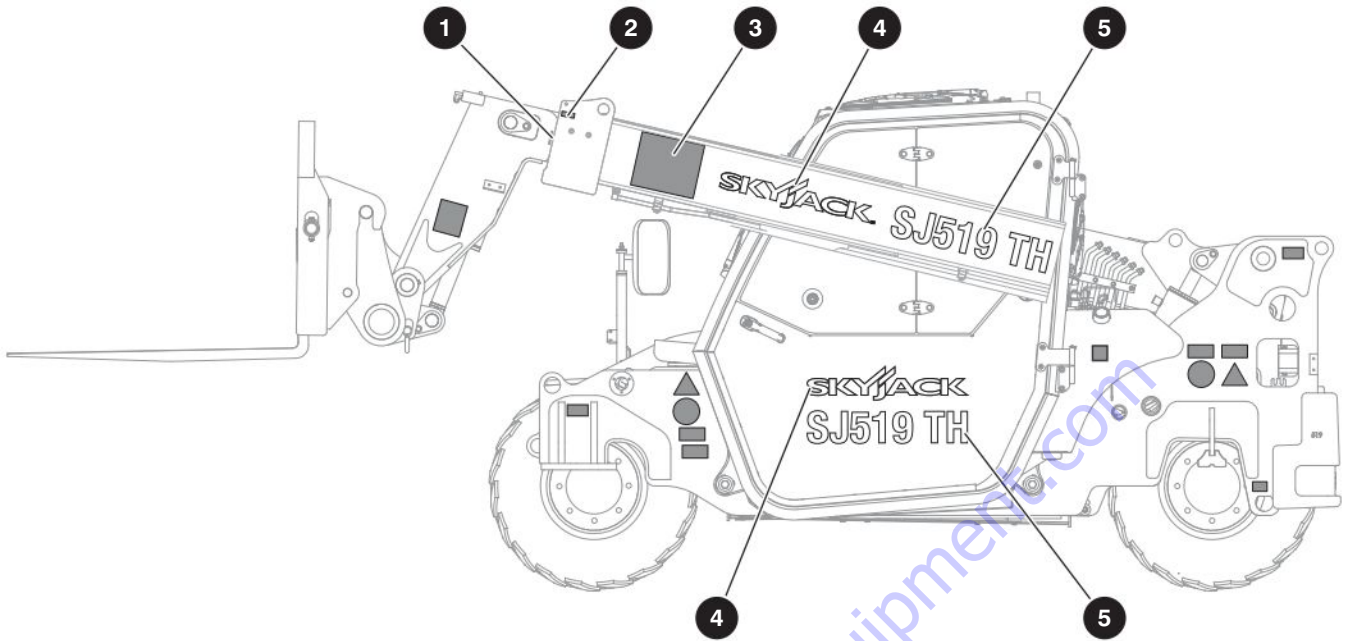

Description

Label Pictorial

1 Extension Letters

Boom extension labels



2 Grease

Grease point

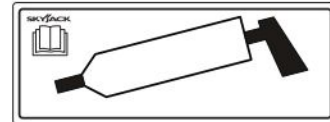

3 Rotation Angle

Boom rotation angle label

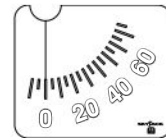

4 Skyjack Logo

Skyjack logo - 63.5 cm (25 in) White



5 Skyjack Logo

Skyjack logo - 63.5 cm (25 in) White



Left Side (continued)

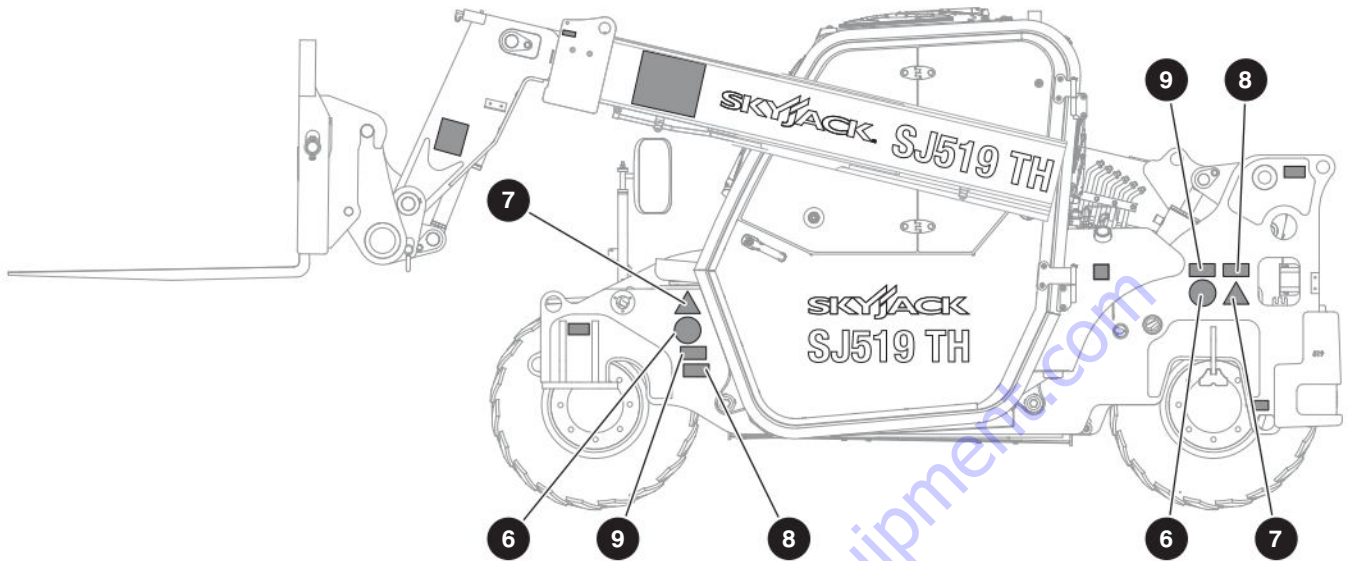

Description

Label Pictorial

- 6 Keep Clear**
Keep clear.



- 7 Body Crushing Hazard**
Warning - Body crushing hazard



- 8 Wheel Specifications**
Refer to manual for wheel type, offset, pressure and torque.

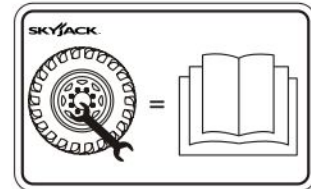

- 9 Tire Pressure or Foam Filled Tires***
Indicates rated tire pressure or foam filled tires.
*Tire pressure will vary, may not be as shown.

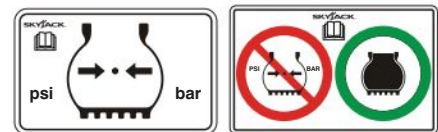

Left Side (continued)

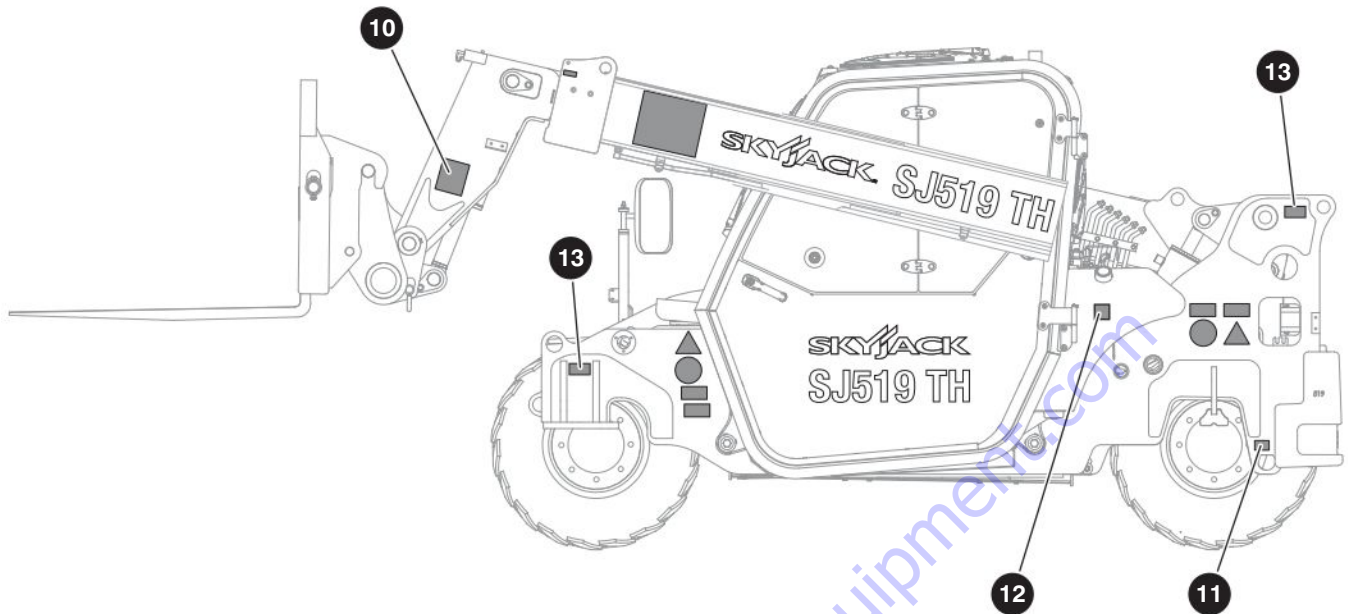

Description	Label Pictorial
<p>10 Unpinned Attachment Unpinned attachment warning</p>	
<p>11 Tie-down Points Only use these points for tying down.</p>	
<p>12 Ultra-low Sulfur Diesel Fuel Only Refill fuel tank with ultra-low sulfur diesel fuel only.</p>	
<p>13 Lifting Point / Tie Down Only use these points for lifting or tying down</p>	

Rear

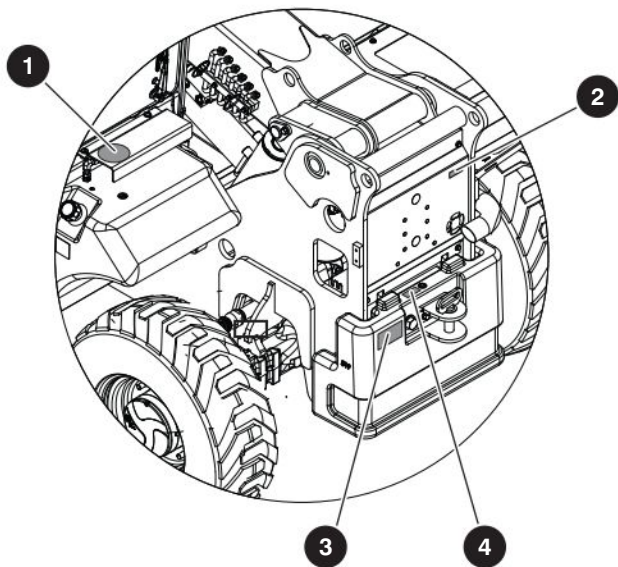

Lifting Shackle on Jib

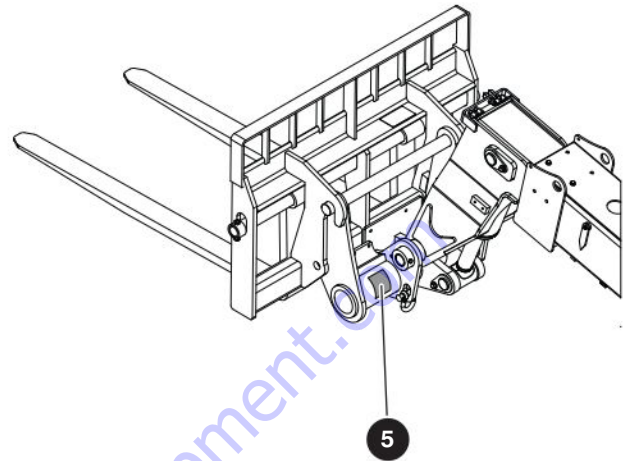

Description	Label Pictorial
<p>1 No Smoking Do not smoke near this location.</p>	
<p>2 Grease Grease point</p>	
<p>3 Towing Capacity Telehandler's maximum towing capacity & tongue weight.</p>	
<p>4 Warning – No Step No step warning</p>	
<p>5 Lifting Hook Capacity Warning Refer to operator's manual and capacity chart inside cab.</p>	

Right Side

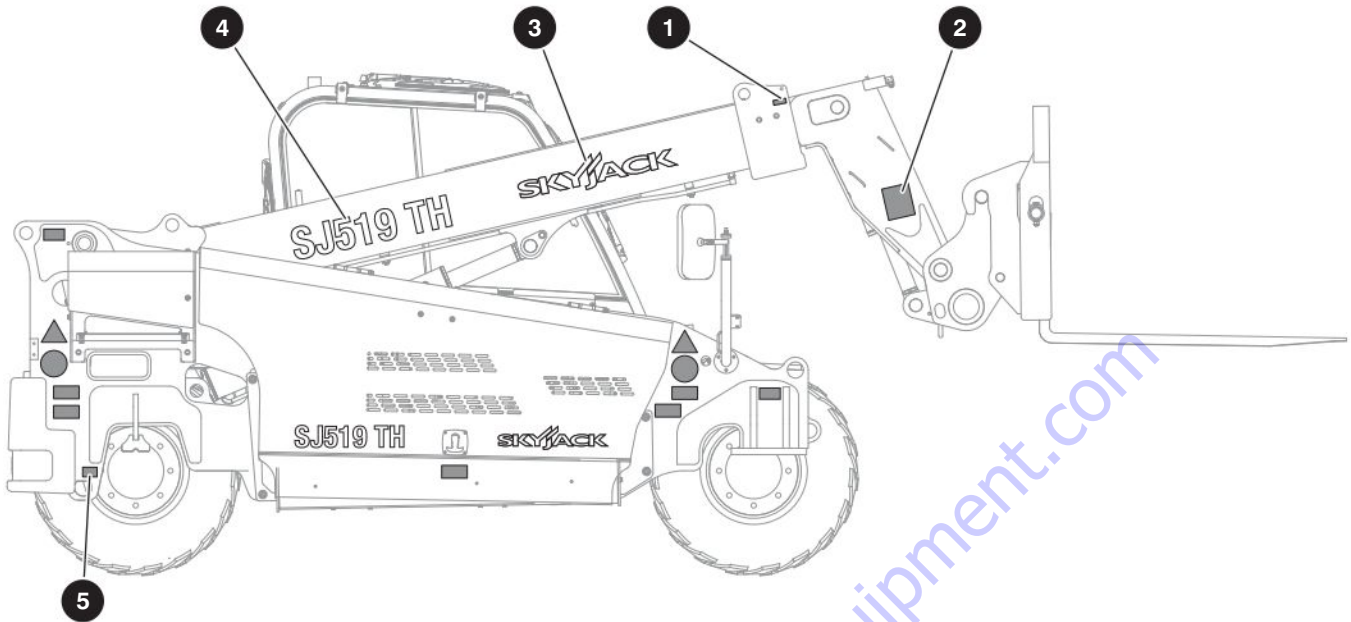

Description

Label Pictorial

- 1 Grease**
Grease point

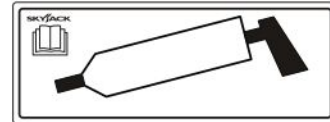

- 2 Unpinned Attachment**
Unpinned attachment warning



- 3 Skyjack Logo**
Skyjack logo - 63.5 cm (25 in) White



- 4 Skyjack Logo**
Skyjack logo - 63.5 cm (25 in) White



- 5 Tie-down Points**
Only use these points for tying down.



Right Side (continued)

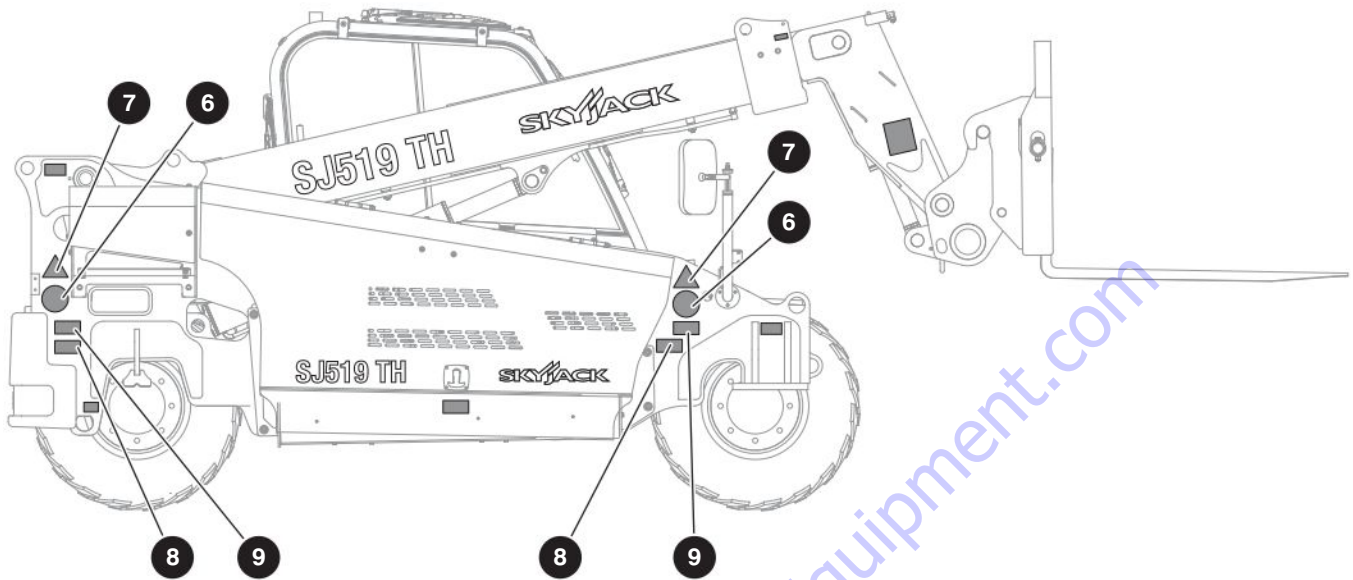

Description

Label Pictorial

- 6 Keep Clear**
Keep clear.



- 7 Body Crushing Hazard**
Warning - Body crushing hazard



- 8 Wheel Specifications**
Refer to manual for wheel type, offset, pressure and torque.

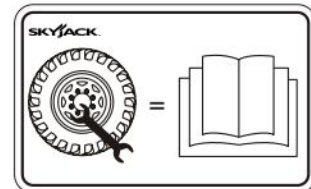

- 9 Tire Pressure or Foam Filled Tires***
Indicates rated tire pressure or foam filled tires.
*Tire pressure will vary, may not be as shown.



Right Side (continued)

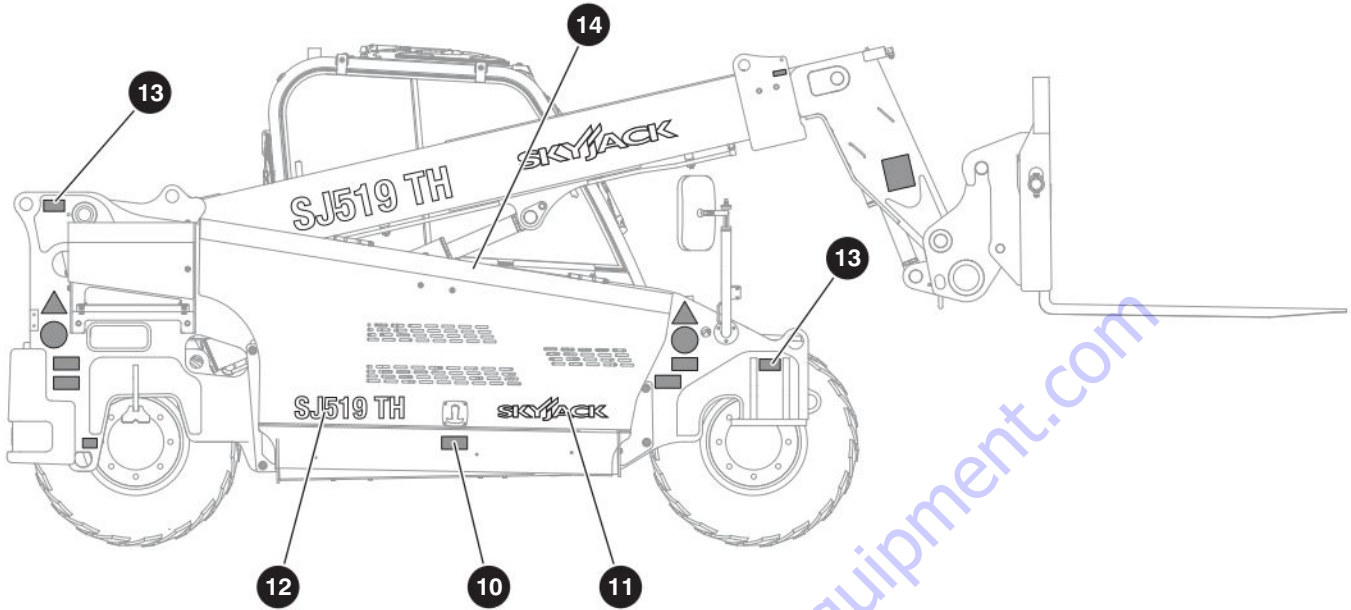

Description

Label Pictorial

- 10 Crushing Hazard**
Warning - Crushing hazard



- 11 Skyjack Logo**
Skyjack logo - 43.2 cm (17 in) White



- 12 Skyjack Logo**
Skyjack logo - 43.2 cm (17 in) White



- 13 Lifting Point / Tie Down**
Only use these points for lifting.



- 14 Hot Surface**
Caution - Hot Surface



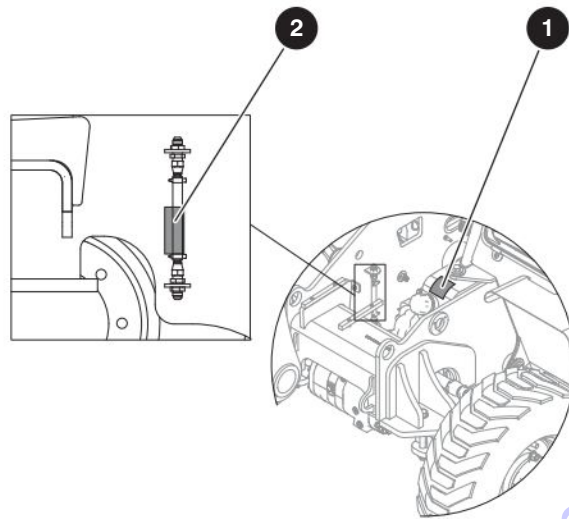

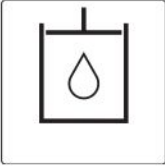
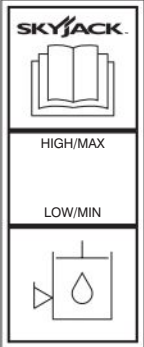
Description	Label Pictorial
<p>1 Hydraulic Oil ATF Dexron III Refill Hydraulic oil tank with ATF Dexron III hydraulic oil.</p>	
<p>2 Hydraulic Oil Level Indicates minimum/maximum oil level.</p>	

Engine Compartment

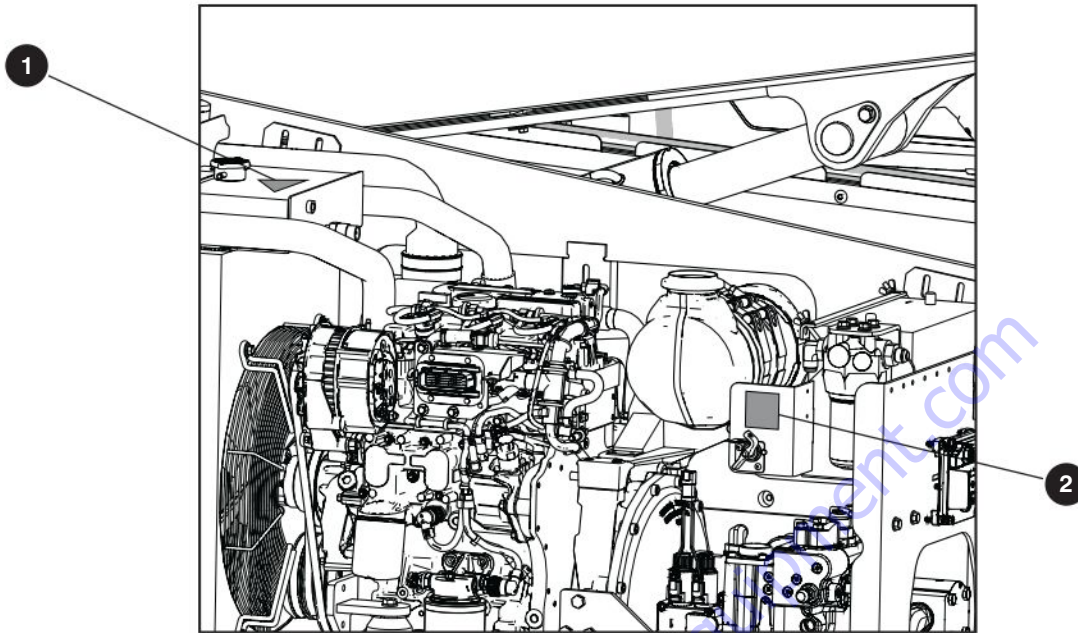

Description

Label Pictorial

1 Caution - Coolant Fill Point

Refer to service manual for coolant fill instructions.



2 Main Power Disconnect Switch

For use during maintenance only.

Rotate clockwise to turn on main power, rotate counterclockwise to turn off main power, insert padlock into position.

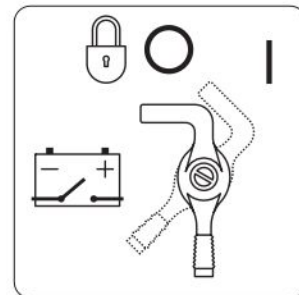

Section 9 – Unique Skyjack Features

Your Skyjack telehandler may be equipped with the following unique features:

ACCESSORYZERS™

Having equipment with features and functionality that allow you and your customers to do more is a vital part of the utilization equation. Skyjack offers a range of accessory products to further expand a given product's adaptability and your power to offer a truly flexible rental choice.

AXLDRIVE™

Skyjack's mechanical "axle based" drive system gives positive traction and excellent rough ground "terrain-ability". This is achieved using an automatic or manual (model dependent) locking differential on the rear axle and limited slip differential on the front axle. This means machines can climb grades of up to 30% in the case of Rough Terrain Scissors Lifts, and 50% in the case of Boom Lifts. This industry leading terrain capability means one can use the Skyjack Rough Terrain Scissor Lifts and Boom Lifts in the most challenging of conditions.

FLEXCAB™

Skyjack's TH series telehandlers feature an innovative cab design that allows fleet operators to easily convert between open and enclosed cabs with simple hand tools, providing increased flexibility for fleet movement and fast response to customer demands. Easily sourced flat glass panels with no custom curved profiles and a bolt-on/bolt-off window retention system ensures minimal downtime and incurred costs for repairing damaged glass in the field.

READYHOOK™

Skyjack's yoke mounted lifting hook is fitted as standard on TH series telehandlers. With capacities that match the maximum lift capability of the telehandler the hook allows the safe under-slinging of loads and avoids the practice of using the forks as an underslung lifting device.

SKYCODED™

At the heart of every Skyjack machine, proven and simplistic control systems using Skyjack's color coded and numbered wiring system make our machines the easiest to trouble shoot and repair. – Black #14 is for the lift function on a 3219, and it is lift on a 63AJ. Using an analog based control system allows Skyjack AWP's to operate using a simplified system with fewer and less expensive components – less maintenance and lower costs.

SMARTORQUE™

Skyjack's TH series of telehandlers use a low horse power, high torque engine that has been engineered to provide the necessary torque and hydraulic performance found in higher horse power engines. This provides the benefit of lower acquisition costs and the employment of minimal emission controlling modules that otherwise are both expensive and complicated. SMARTORQUE™ means no diesel particulate filter (DPF), no diesel exhaust fluid (DEF) and no other active exhaust after treatment on standard engines for Tier IV Final.



WARNING

Cancer and Reproductive Harm-
<https://www.p65warnings.ca.gov/>.

To order go to DiscountEquipment.com

TO PURCHASE THIS PRODUCT PLEASE CONTACT US



**Equipment Financing and
Extended Warranties Available**



**Discount-Equipment.com is your online resource for
commercial and industrial quality parts and equipment sales.**

561-964-4949

visit us on line @ www.discount-equipment.com

Select an option below to find your Equipment

Search by Manufacturer

Search by Product Type

Request a Quote

We sell worldwide for the brands: Genie, Terex, JLG, MultiQuip, Mikasa, Essick, Whiteman, Mayco, Toro Stone, Diamond Products, Generac Magnum, Airman, Haulotte, Barreto, Power Blanket, Nifty Lift, Atlas Copco, Chicago Pneumatic, Allmand, Miller Curber, Skyjack, Lull, Skytrak, Tsurumi, Husquvarna Target, Stow, Wacker, Sakai, Mi-T-M, Sullair, Basic, Dynapac, MBW, Weber, Bartell, Bennar Newman, Haulotte, Ditch Runner, Menegotti, Morrison, Contec, Buddy, Crown, Edco, Wyco, Bomag, Laymor, EZ Trench, Bil-Jax, F.S. Curtis, Gehl Pavers, Heli, Honda, ICS/PowerGrit, IHI, Partner, Imer, Clipper, MMD, Koshin, Rice, CH&E, General Equipment, Amida, Coleman, NAC, Gradall, Square Shooter, Kent, Stanley, Tamco, Toku, Hatz, Kohler, Robin, Wisconsin, Northrock, Oztec, Toker TK, Rol-Air, APT, Wylie, Ingersoll Rand / Doosan, Innovatech, Con X, Ammann, Mecalac, Makinex, Smith Surface Prep, Small Line, Wanco, Yanmar



www.Discount-Equipment.com

To order go to Discount-Equipment.com

SKYJACK[™]