



[www.Discount-Equipment.com](http://www.Discount-Equipment.com)

**SKYJACK**

# SERVICE MANUAL

---

**SJ519 TH**

TELEHANDLERS

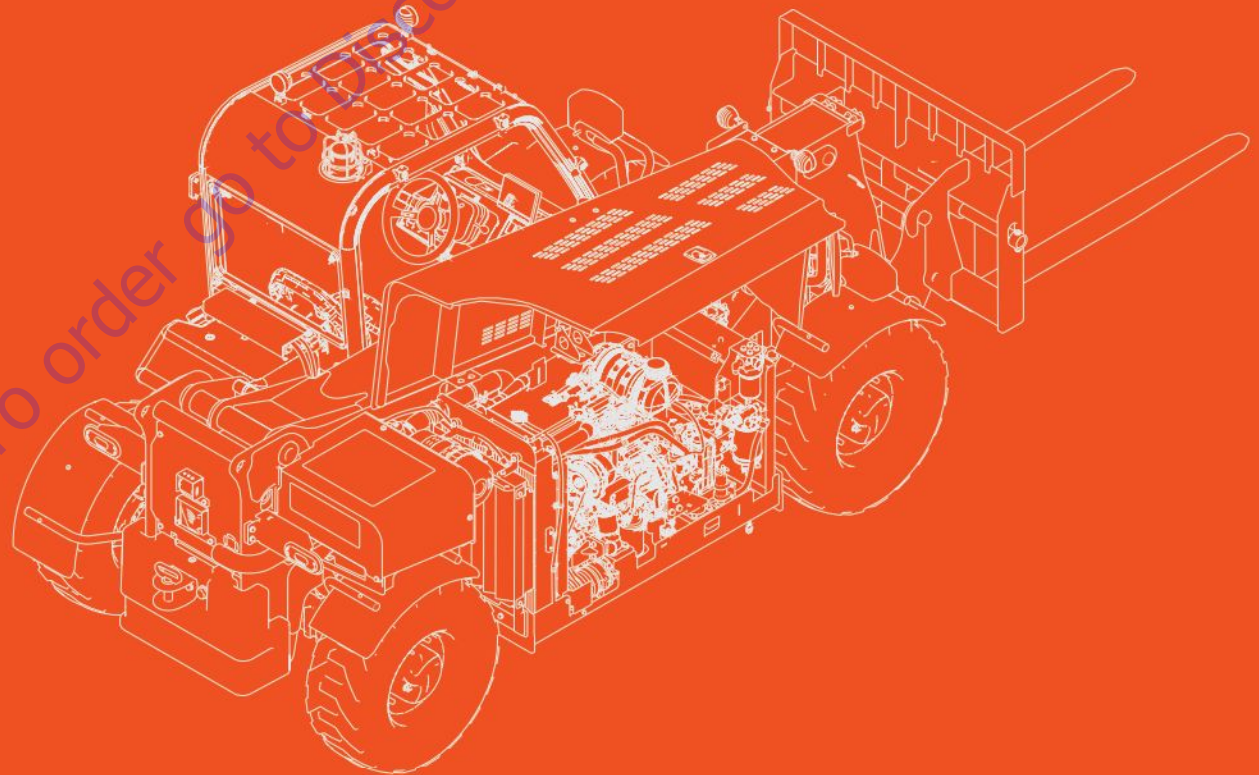

**216942AC**

October 2020

ANSI

**TO PURCHASE THIS PRODUCT PLEASE CONTACT US**



**Equipment Financing and  
Extended Warranties Available**



**Discount-Equipment.com is your online resource for  
commercial and industrial quality parts and equipment sales.**

**561-964-4949**

**visit us on line @ [www.discount-equipment.com](http://www.discount-equipment.com)**

Select an option below to find your Equipment

**Search by Manufacturer**

**Search by Product Type**

**Request a Quote**

We sell worldwide for the brands: Genie, Terex, JLG, MultiQuip, Mikasa, Essick, Whiteman, Mayco, Toro Stone, Diamond Products, Generac Magnum, Airman, Haulotte, Barreto, Power Blanket, Nifty Lift, Atlas Copco, Chicago Pneumatic, Allmand, Miller Curber, Skyjack, Lull, Skytrak, Tsurumi, Husquvarna Target, Stow, Wacker, Sakai, Mi-T-M, Sullair, Basic, Dynapac, MBW, Weber, Bartell, Bennar Newman, Haulotte, Ditch Runner, Menegotti, Morrison, Contec, Buddy, Crown, Edco, Wyco, Bomag, Laymor, EZ Trench, Bil-Jax, F.S. Curtis, Gehl Pavers, Heli, Honda, ICS/PowerGrit, IHI, Partner, Imer, Clipper, MMD, Koshin, Rice, CH&E, General Equipment, Amida, Coleman, NAC, Gradall, Square Shooter, Kent, Stanley, Tamco, Toku, Hatz, Kohler, Robin, Wisconsin, Northrock, Oztec, Toker TK, Rol-Air, APT, Wylie, Ingersoll Rand / Doosan, Innovatech, Con X, Ammann, Mecalac, Makinex, Smith Surface Prep, Small Line, Wanco, Yanmar

**This manual is based on Serial Number(s):**

**SJ519 TH: 87 500 000 to 87 599 999**

To order go to [Discount-Equipment.com](http://Discount-Equipment.com)

---

**THIS SAFETY ALERT SYMBOL MEANS ATTENTION!**



**BECOME ALERT! YOUR SAFETY IS INVOLVED.**

The Safety Alert Symbol identifies important safety messages on telehandlers, safety signs in manuals or elsewhere. When you see this symbol, be alert to the possibility of personal injury or death. Follow the instructions in the safety message.

** DANGER**

**DANGER** indicates an imminently hazardous situation which, if not avoided, will result in death or serious injury.

** WARNING**

**WARNING** indicates a potentially hazardous situation which, if not avoided, could result in death or serious injury.

** CAUTION**

**CAUTION** indicates a potentially hazardous situation which, if not avoided, may result in minor or moderate injury. It may also be used to alert against unsafe practices.

**IMPORTANT**

**IMPORTANT** indicates a procedure essential for safe operation and which, if not followed, may result in a malfunction or damage to the telehandler.

# Table of Contents

Table of Contents .....	5
<b>Section 1 – Scheduled Maintenance</b> .....	<b>9</b>
<b>1.1 Read and Heed</b> .....	<b>9</b>
1.1-1 Telehandler Definition .....	9
1.1-2 Purpose of Equipment .....	9
1.1-3 Use of Equipment .....	9
1.1-4 Manual .....	9
1.1-5 Service Policy and Warranty .....	9
1.1-6 Operator Safety Reminders, Warnings and Precautions .....	9
<b>1.2 Maintenance and Inspection Schedule</b> .....	<b>10</b>
1.2-1 Owner's Annual Inspection Record .....	10
1.2-2 Replacement Parts .....	10
1.2-3 Maintenance and Service Safety Tips .....	10
<b>1.3 Hydraulic System &amp; Component Maintenance and Repair</b> .....	<b>11</b>
1.3-1 Maintenance Hints .....	11
<b>1.4 About this Section</b> .....	<b>12</b>
1.4-1 Service Bulletins .....	12
1.4-2 Maintenance and Inspection .....	12
1.4-3 Maintenance Instructions .....	12
<b>1.5 Scheduled Maintenance Inspections</b> .....	<b>14</b>
1.5-1 Labels - A .....	14
1.5-2 Electrical .....	14
1.5-3 Hydraulic .....	14
1.5-4 Cylinders - A .....	14
1.5-5 Mirrors - A .....	15
1.5-6 Frame .....	15
1.5-7 Engine Compartment .....	18
1.5-8 Boom - A .....	19
1.5-9 Lifting Attachment - A .....	19
1.5-10 Grease Points - B .....	19
1.5-11 Operator's Cab .....	20
1.5-12 Operator's Cab Controls .....	21
<b>1.6 Function Tests</b> .....	<b>21</b>
<b>Section 2 – Maintenance Tables</b> .....	<b>23</b>
<b>2.1 Standard and Optional Equipment</b> .....	<b>24</b>
<b>2.2 Specifications and Features</b> .....	<b>25</b>
<b>2.3 Tire/Wheel Specifications</b> .....	<b>26</b>

2.4	Recommended Fluids/Lubrications	27
2.5	Pressure Setting	28
2.6	Standard Hose Numbering System	29
2.7	Torque Specifications for Fasteners (US)	31
2.8	Torque Specifications for Fasteners (Metric)	32
2.9	Torque Specifications for Hydraulic Couplings & Hoses	33
<b>Section 3 – System Component Identification and Schematics</b>		<b>35</b>
3.1	Electrical Symbol Chart	36
3.2	Hydraulic Symbol Chart	37
3.3	Electrical Schematic Parts List	38
3.4	Hydraulic Schematic Parts List	41
3.5	Hydraulic Pump and Return Filter Ports Identification	43
3.6	Steer Manifold	44
3.7	Main Manifold	45
3.8	Pilot Manifold	46
3.9	Pedal Ports Identification	48
3.11	Major Components Identification and Location	50
3.12	Glow Plug Harness	51
3.13	Road Lights Harness	52
3.14	Boom Lights Harness	53
3.15	Beacon Light Harness	54
3.16	Work Lights Harness	55
3.17	Console Harness	56
3.18	Console Harness Wiring	57
3.19	Engine Harness	58
3.20	Engine Harness Wiring	59
3.21	Electrical Schematic	60
3.22	Hydraulic Schematic	63
<b>Section 4 – Troubleshooting Information</b>		<b>64</b>
4.1	Introduction	64
4.2	Electrical System	65
4.2-1	Engine Will Not Crank	65
4.2-2	Engine Cranks But Will Not Run	67
4.2-3	Park Brake Will Not Release	67
4.2-4	Forward or Reverse Will Not Engage	68
4.2-5	No Forward Drive	69
4.2-6	No Reverse Drive	69
4.2-7	Front Steer Mode Only, Fuel gauge inoperative	69
4.2-8	Front Steer Mode Only	69
4.2-9	No 4W (Round) Steer Mode	70
4.2-10	No Crab Steer Mode	70

4.2-11	<i>Function Does Not Switch from Boom Raise/Lower To Carriage Tilt Up/Down With Carriage Tilt Switch SW6 Depressed.</i>	70
<b>4.3</b>	<b>Hydraulic System.</b>	<b>71</b>
4.3-1	<i>All Controls inoperative.</i>	71
4.3-2	<i>All Boom Functions Inoperative</i>	71
4.3-3	<i>No Boom Raise.</i>	71
4.3-4	<i>No Boom Lower</i>	71
4.3-5	<i>No Telescope Extend</i>	72
4.3-6	<i>No Telescope Retract</i>	72
4.3-7	<i>No Carriage Tilt Up</i>	72
4.3-8	<i>No carriage Tilt Down</i>	73
4.3-9	<i>No Aux. Functions</i>	73
4.3-10	<i>Hard or No Steering</i>	73
4.3-11	<i>Park Brake will not Release</i>	74
4.3-12	<i>Park Brake Will Not Engage</i>	74
4.3-13	<i>Service Brake Will Not Engage</i>	74
4.3-14	<i>No Drive Function Forward or Reverse.</i>	74
4.3-15	<i>No Forward Drive</i>	75
4.3-16	<i>No Reverse Drive</i>	75
<b>Section 5 – Procedures</b>		<b>76</b>
<b>5.1</b>	<b>General.</b>	<b>76</b>
5.1-1	<i>Safety and Workmanship</i>	76
5.1-2	<i>Engine and Transmission</i>	76
<b>5.2</b>	<b>10 Hour or Daily Routine Maintenance.</b>	<b>77</b>
5.2-1	<i>Check Engine Oil Level</i>	77
5.2-2	<i>Check Coolant Level, Radiator and Hoses.</i>	77
5.2-3	<i>Check Air Cleaner Restriction and Filter Elements.</i>	78
5.2-4	<i>Check Hydraulic Oil Level</i>	79
5.2-5	<i>Drain Fuel/Water Separator</i>	79
5.2-6	<i>Fuel Tank.</i>	79
5.2-7	<i>Check Parking Brake</i>	79
5.2-8	<i>Check Tire Pressure and Condition</i>	80
5.2-9	<i>Check Seat Belt and Mounting Hardware</i>	80
5.2-10	<i>Check Windshield Washer Fluid Level and Wiper Condition</i>	80
<b>5.3</b>	<b>50 Hour or Weekly Routine Maintenance.</b>	<b>81</b>
5.3-1	<i>Grease Axle Pivot Bearings and King Pins</i>	81
5.3-2	<i>Grease Drive Shaft U-joints and slip joints</i>	81
5.3-3	<i>Check Fork Pins</i>	82
5.3-4	<i>Wear Pads Greasing</i>	82
<b>5.4</b>	<b>250 Hour or Quarterly Routine Maintenance</b>	<b>83</b>
5.4-1	<i>Check Lug Nut Torque</i>	83

5.4-2	<i>Check Oil Level in Axle Differential Planetary wheel Ends</i> . . . . .	83
5.4-3	<i>Check Oil level in Axle differentials.</i> . . . . .	84
5.4-4	<i>Replace Engine Oil and Filter</i> . . . . .	84
5.4-5	<i>Change Engine Fuel filter and Fuel/Water Separator</i> . . . . .	86
5.4-6	<i>Clean Hydraulic Tank Breather</i> . . . . .	87
5.4-7	<i>Torque Axle Mounting Bolts</i> . . . . .	87
5.4-8	<i>Check Boom Wear Pad Clearances</i> . . . . .	88
<b>5.5</b>	<b>1000 Hour or Annual Routine Maintenance</b> . . . . .	<b>89</b>
5.5-1	<i>Change Hydraulic Oil Filter</i> . . . . .	89
5.5-2	<i>Change Hydraulic Oil and Clean Hydraulic Tank</i> . . . . .	90
5.5-3	<i>Change Axle Differential Oil</i> . . . . .	91
5.5-4	<i>Change Axle Planetary Oil.</i> . . . . .	91
5.5-5	<i>Change Engine Coolant</i> . . . . .	92
<b>5.6</b>	<b>Non-Routine Maintenance.</b> . . . . .	<b>93</b>
5.6-1	<i>Wear Pads Replacement Procedure.</i> . . . . .	93
5.6-2	<i>Display Fault Codes</i> . . . . .	95
5.6-3	<i>Hydraulic Pressure Test Procedure</i> . . . . .	100
5.6-4	<i>Bleeding Hydraulic Circuits</i> . . . . .	105
5.6-5	<i>Brake Inspection.</i> . . . . .	106

To order go to Discount-Equipment.com



---

# Section 1 – Scheduled Maintenance

## 1.1 Read and Heed

SKYJACK is continuously improving and expanding product features on its equipment, therefore, specifications and dimensions are subject to change without notice.

### 1.1-1 Telehandler Definition

A material handler designed primarily as a fork truck with a pivoting telescopic boom which enables it to pick up and place loads at distances as well as various lift heights.

### 1.1-2 Purpose of Equipment

The SKYJACK telehandlers are designed to lift, handle and transport agricultural or industrial products by means of specific attachments.

### 1.1-3 Use of Equipment

The telehandler is a highly maneuverable, mobile work station. Lifting, handling and driving must be on a flat, level, compacted surface. It can be driven over uneven terrain only when boom is fully lowered.

### 1.1-4 Manual

**Operating Manual:** The operating manual is considered a fundamental part of the telehandler. It is a very important way to communicate necessary safety information to users and operators. A complete and legible copy of this manual must be kept in the provided weather-resistant storage compartment on the telehandler at all times.

**Service & Maintenance:** The purpose of this manual is to provide the customer with the servicing and maintenance procedures essential for the promotion of proper machine operation for its intended purpose.

All information in this manual should be read and understood before any attempt is made to service the machine. The updated copy of the manuals are found on the company's website: [www.skyjack.com](http://www.skyjack.com).

### 1.1-5 Service Policy and Warranty

SKYJACK warrants each new product to be free of defective parts and workmanship for the first 2 years or 3000 hours, whichever occurs first. Any defective part will be replaced or repaired by your local SKYJACK dealer at no charge for parts or labor. In addition, all products have a 5 year structural warranty. Contact the SKYJACK Service Department for warranty statement extensions or exclusions.

### 1.1-6 Operator Safety Reminders, Warnings and Precautions

Operator safety is SKYJACK's priority. The operator should comply with all applicable safety-related reminders, warnings and precautions found in the Operating Manual. They should be read and understood completely before operating the telehandler.

## 1.2 Maintenance and Inspection Schedule

The actual operating environment of the work platform governs the use of the maintenance schedule. The inspection points covered in [Table 1.1 Maintenance and Inspection Checklist](#), indicates the areas of the telehandler to be maintained or inspected and at what intervals the maintenance and inspections are to be performed.

### 1.2-1 Owner's Annual Inspection Record

It is the responsibility of the owner to arrange quarterly and annual inspections of the telehandler. The Owner's Annual Inspection Record is to be used for recording the date of the inspection, owner's name, and the person responsible for the inspection of the telehandler.

### 1.2-2 Replacement Parts

Use only original replacement parts. Parts such as wheels, etc. with weight and dimensions different from original parts will affect stability of the telehandler and must not be used without manufacturer's consent.

All replacement tires must be of the same size and load rating as originally supplied tires; to maintain safety and stability of telehandler.

Replacement attachments must be equivalent to the originals and be associated with manufacturer approved capacity charts.

Consult SKYJACK's Service Department for optional tires specifications and installation.

### **WARNING**

**Any unit that is damaged or not operating properly must be immediately tagged and removed from service until proper repairs are completed.**

### 1.2-3 Maintenance and Service Safety Tips

Maintenance and repair should only be performed by personnel who are trained and qualified to service this telehandler.

All maintenance and service procedures should be performed in a well lighted and well ventilated area.

Anyone operating or servicing this telehandler must read and completely understand all operating instructions and safety hazards in this manual and operating manual.

All tools, supports and lifting equipment to be used must be of proper rated load and in good working order before any service work begins. Work area should be kept clean and free of debris to avoid contaminating components while servicing.

Ensure personnel are clear from under unsupported components/systems that are at risk of movement during maintenance.

All service personnel must be familiar with employer and governmental regulations that apply to servicing this type of equipment.

Keep sparks and flames away from all flammable or combustible materials.

Properly dispose of all waste material such as lubricants, rags, and old parts according to the relative law provisions obtaining in the country.

Before attempting any repair work, disconnect the main power connectors.

Keep personnel clear of components, systems or unsupported loads that may move unexpectedly during maintenance procedures.

Preventive maintenance is the easiest and least expensive type of maintenance.

### Jobsite Inspection

- Do not use in hazardous locations.
- Perform a thorough jobsite inspection prior to operating the telehandler, to identify potential hazards in your work area.
- Be aware of moving equipment in the area. Take appropriate actions to avoid possible collision.

## 1.3 Hydraulic System & Component Maintenance and Repair

The following points should be kept in mind when working on the hydraulic system or any component:

### WARNING

**Escaping fluid from a hydraulic pressure leak can damage your eyes, penetrate the skin and cause serious injury. Use proper personal protection at all times.**

1. Any structure has limits of strength and durability. To prevent failure of structural parts of hydraulic components, relief valves which limit pressure to safe operating values are included in the hydraulic circuits.
2. Tolerance of working parts in the hydraulic system is very close. Even small amounts of dirt or foreign materials in the system can cause wear or damage to components, as well as general faulty operation of the hydraulic system. Every precaution must be taken to assure absolute cleanliness of the hydraulic oil.
3. Whenever there is a hydraulic system failure which gives reason to believe that there are metal particles or foreign materials in the system, drain and flush the entire system and replace the filter cartridges. A complete change of oil must be performed under these circumstances.
4. Whenever the hydraulic system is drained, check the magnets in the hydraulic reservoir for metal particles. If metal particles are present, flush the entire system and add a new change of oil. The presence of metal particles also may indicate the possibility of imminent component failure. A very small amount of fine particles is normal.
5. All containers and funnels used in handling hydraulic oil must be absolutely clean. Use a funnel when necessary for filling the hydraulic oil reservoir, and fill the reservoir only through the filter opening. The use of cloth to strain the oil should be avoided to prevent lint from getting into the system.
6. When removing any hydraulic component, be sure to cap and tag all hydraulic lines involved. Also, plug the ports of the removed components.
7. All hydraulic components must be disassembled in spotlessly clean surroundings. During disassembly, pay particular attention to the identification of parts to assure proper reassembly. Clean all metal parts in a clean mineral oil solvent. Be sure to thoroughly clean all internal passages. After the parts have been dried thoroughly, lay them on a clean, lint-free surface for inspection.
8. Replace all O-rings and seals when overhauling any component. Lubricate all parts with clean hydraulic oil before reassembly. Use small amounts of petroleum jelly to hold O-rings in place during assembly.
9. Be sure to replace any lost hydraulic oil when completing the installation of the repaired component, and bleed any air from the system when required.
10. All hydraulic connections must be kept tight. A loose connection in a pressure line will permit the oil to leak out or air to be drawn into the system. Air in the system can cause damage to the components and noisy or erratic system operation.

### 1.3-1 Maintenance Hints

Three simple maintenance procedures have the greatest effect on the hydraulic system performance, efficiency and life. Yet, the very simplicity of them may be the reason they are so often overlooked. They are simply these:

1. Change filters annually. The filters will need to be changed more often depending on the operating conditions. Dirty, dusty, high moisture environments may cause the hydraulic system to be contaminated more quickly.
2. Maintain a sufficient quantity of clean hydraulic oil of the proper type and viscosity in the hydraulic reservoir.
3. Keep all connections tight.

## 1.4 About this Section

This section contains the maintenance and inspection schedule that is to be performed.

References are made to the procedures in section 5 of the operating manual that outline detailed step-by-step instructions for checks and replacements.

### 1.4-1 Service Bulletins

Before performing any scheduled maintenance inspection procedure, refer to service bulletins found in our web site: [www.skyjack.com](http://www.skyjack.com) for updates related to service and maintenance of this telehandler.

### 1.4-2 Maintenance and Inspection

Death or injury can result if the telehandler is not kept in good working order. Inspection and maintenance should be performed by competent personnel who are trained and qualified on maintenance of this telehandler.

#### WARNING

**Failure to perform each procedure as presented and scheduled may cause death, serious injury or substantial damage.**

#### NOTE

*Preventive maintenance is the easiest and least expensive type of maintenance.*

- Unless otherwise specified, perform each maintenance procedure with the telehandler in the following configuration:
  - Telehandler parked on a flat and level surface
  - Engine is turned off.
- Repair any damaged or malfunction components before operating telehandler.
- Keep records on all inspections.

### 1.4-3 Maintenance Instructions

This manual consists of four schedules to be done for maintaining on an telehandler. Inspection schedule frequency is shown below:

Issue or Symptom		
PDI/Frequent	<b>B</b>	Perform PDI prior to each delivery, or Frequent Inspection every 3 months or 150 hours.
Annual	<b>B + C</b>	Perform Scheduled Maintenance Inspections every year.
Additional	*	Perform at time sensitive maintenance intervals.

- Make copies of the maintenance and inspection checklist to be used for each inspection.
- Check the schedule on the checklist for the type of inspection to be performed.
- Place a check in the appropriate box after each inspection procedure is completed.
- Use the maintenance and inspection checklist and step-by-step procedures in section 5 of the operating manual to perform these inspections.
- If any inspection receives a fail, tag and remove the telehandler from service.
- If any telehandler component(s) has been repaired, an inspection must be performed again before removing the tag. Place a check in the repair column.

#### Legend

Pass	<b>P</b>
Fail	<b>F</b>
Repaired	<b>R</b>
Not applicable	<b>N/A</b>

# Table 1.1 Maintenance and Inspection Checklist



**Table 1.1 MAINTENANCE AND INSPECTION CHECKLIST**

Serial Number: \_\_\_\_\_  
 Model: \_\_\_\_\_  
 Hourmeter Reading: \_\_\_\_\_ Operator's Name (Printed): \_\_\_\_\_  
 Date: \_\_\_\_\_  
 Time: \_\_\_\_\_ Operator's Signature: \_\_\_\_\_

Each item shall be inspected using the appropriate section of the Skyjack operating manual. As each item is inspected, write the appropriate grade in the box.

- P** - PASS
- F** - FAIL
- R** - REPAIRED

- INSPECTION FREQUENCY**
- DAILY
  - WEEKLY or 40 HOURS
  - QUARTERLY OR 250 HOURS
  - ANNUALLY or 1000 HOURS

Inspection Schedule	
Daily	A
Weekly or 50 Hours	A + B
Quarterly or 250 Hours	A + B + C
Annually or 1000 Hours	A + B + C + D

Schedule	P	F	R
<b>Schedule Maintenance Inspections</b>			
Labels	A		
Electrical	A		
Mirrors	A		
Hydraulic	A		
Cylinders	A,B,C,D		
<b>Frame</b>			
Wheel/Tire Assembly	A		
Air-filled Tires	A		
Foam-filled Tires	A		
Battery and Cables	A		
Hydraulic Tank	A		
Hydraulic Oil	A,D		
Engine Intake Air Filter	A,B,C		
Tilt Switch	A,B,C,D		
<b>Drive Axles</b>			
Hub Oil	D		
Differential Oil	D		
Pinion Seal	A		
Inner and Outer Shaft Seals	A		
Hub Seals	A		
King Pins	C,D		
Check Drive Shafts and U-Joints	C,D		
Axle Mounting Pins and Bushings	C,D		
Axle Housing	A		
Steer Cylinder Assembly	A		
Steer Linkage	A		
<b>Engine Compartment</b>			
Engine Oil	A,C		
Engine Coolant Level	A		
Fuel Leaks	A		
Belts and Hoses	A		
Fuel Tank	A		
Change Fuel Filter	A,C		
Drain Fuel/Water Separator	C,D		
Change Oil Filters	A,C		
Charge Accumulators (if equipped)	A		
<b>Transmission</b>			
Operate and Check Shifting	A		
Check for Leaks	A		
Change Transmission Oil	D		
Change Oil Filter	D		
Hydraulic Pump	A		

Schedule	P	F	R
<b>Boom</b>			
Main pins and bushings	C,D		
subcarriage pins and bushings	C,D		
Rollers and Tracks	C,D		
Slide Pads	B,C,D		
Chain(s)	A,C		
Boom Angle Indicator	A		
Proximity Sensors	A		
Lifting Attachment(s)	A		
Forks	A		
Fork Bars and Locks	A		
Quick Attach apron	A		
<b>Grease Fittings</b>			
Grease Fittings on Frame	B		
Grease Fittings on Boom Assembly	B		
<b>Operator's Cab</b>			
Seat	A		
Pedals	A		
Manual	A		
Operator's Cab Controls	A		
<b>Function Tests</b>			
<b>Operator's Cab Controls</b>			
Test Starter Operation	A		
Test Horn	A		
Test Lights (If Equipped)	A		
Test Boom and Attachment Functions	A		
Test Frame Leveling and Level Indicator	A		
Test Frame Leveling and Boom Interlock	A		
Test Accelerator Pedal	A		
Test Reverse Alarm, Driving & Service Brake	A		
Test Steering	A		
Test Positive Shut-off Valve (if equipped)	A		
Test Parking Brake	A		
Test Outriggers (If Equipped)	A		

256C

- A** - Perform Visual and Daily Maintenance Inspections & Functions Test. Refer to Section 2.8 of the Operating Manual.
- B** - Perform Scheduled Maintenance Inspection every week or 40 hrs. Refer to Section 1 of this manual.
- C** - Perform Scheduled Maintenance Inspection every 3 months or 250 hours. Refer to Section 1 of this manual.
- D** - Perform Scheduled Maintenance Inspection every year or 1000 hours. Refer to Section 1 of this manual.

**Note:** Make a copy of this page or visit the Skyjack web site: [www.skyjack.com](http://www.skyjack.com) for a printable copy.

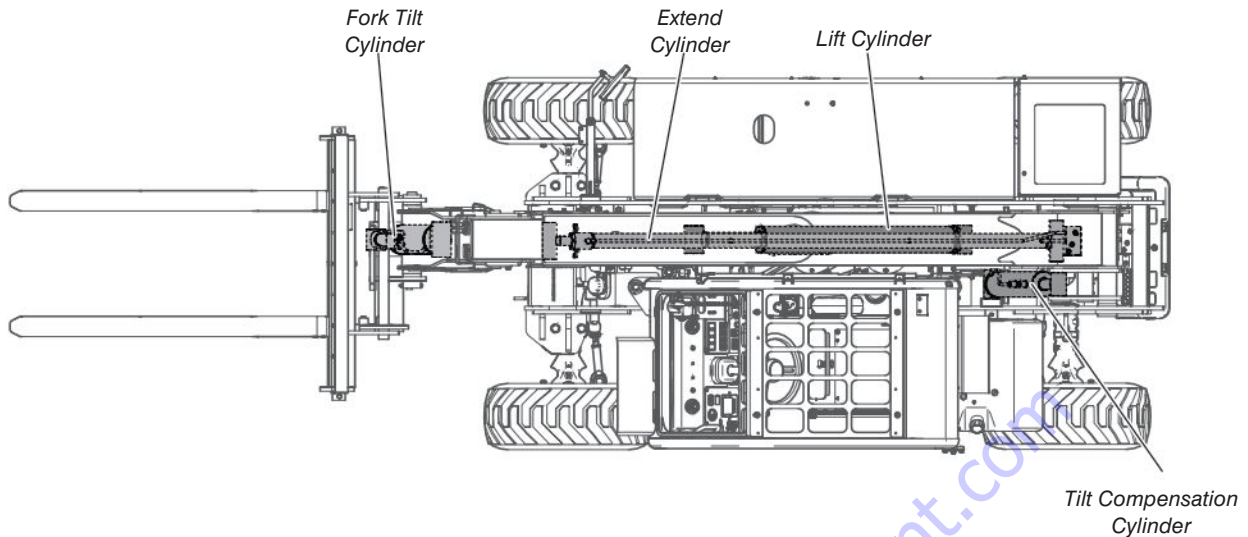

## 1.5 Scheduled Maintenance Inspections

Before performing the visual and daily maintenance inspections, ensure that the telehandler is parked on a firm level surface.

Begin the visual and daily maintenance inspections by checking each item in sequence for the conditions listed in this section.

### **WARNING**

To avoid injury, do not operate a telehandler until all malfunctions have been corrected.

### **WARNING**

To avoid possible injury, ensure telehandler power is off during your visual and daily maintenance inspections.

### **NOTE**

While performing visual and daily inspections in different areas, be aware to also inspect all switches, electrical and hydraulic components.

#### 1.5-1 Labels - **A**

Refer to the labels section of the operating manual and determine that all labels are in place and are legible.

#### 1.5-2 Electrical

Maintaining the electrical components is essential to good performance and service life of the telehandler.

Ensure proper operation of all gauges.

Inspect the following areas for chafed, corroded and loose wires:

- boom wiring harnesses - **A**
- frame wiring harnesses - **A**
- cab wiring harnesses - **A**

Ensure electrical devices are properly secured with no visible damage. Ensure there are no loose or missing parts.

#### 1.5-3 Hydraulic

Maintaining the hydraulic components is essential to good performance and service life of the telehandler. Perform a visual inspection and check for leaks around the following areas:

- hydraulic tank, filter(s), fittings, hoses, pump, and frame surface
- all hydraulic cylinders - **A**
- all hydraulic manifolds - **A**
- underside of the frame - **A**
- ground area under the telehandler - **A**

#### 1.5-4 Cylinders - **A**

Ensure all cylinders are properly secured and there is no evidence of leakage.

Grease weekly and check pins and bushings to ensure there is no evidence of damage.

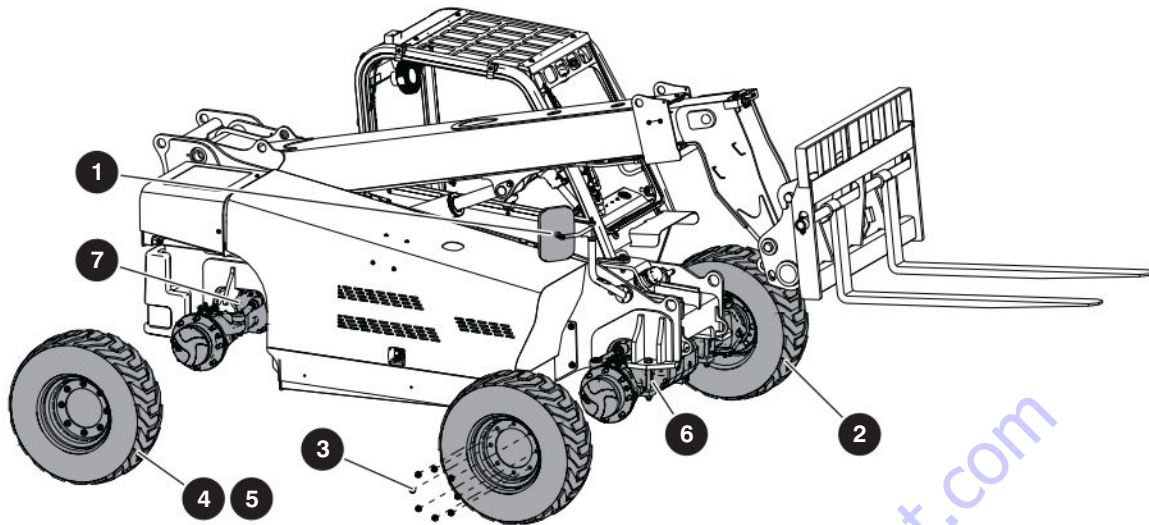

### 1.5-5 Mirrors - A

- ❶ **Mirrors:** Ensure mirrors are properly secured with no visible damage.

### 1.5-6 Frame

#### ❷ **Wheel/Tire Assembly - A**

Tire and/or wheel failure could result in a telehandler tip-over. Component damage may also result if problems are not discovered and repaired in a timely fashion.

- Check all tire treads and sidewalls for cuts or cracks that expose the cord plies.
- Check for punctures, holes and unusual wear.
- Check each wheel rim for damage and cracked welds.
- Check each **lug nut** ❸ for proper torque to ensure none are loose. Refer to [Section 2.3](#) for wheel/tire specifications.

#### ❹ **Air-filled Tires - A**

To safeguard maximum stability, achieve optimum telehandler handling and minimize tire wear, it is essential to maintain proper pressure in all air-filled tires. Refer to tire pressure label.

- Check each tire with an air pressure gauge and add air as needed.

### **WARNING**

**An improperly inflated tire may cause death or serious injury.**

#### ❺ **Foam-filled Tires - A**

Tire condition can vary significantly depending on telehandler use, job site environment and preventative maintenance measures. Inspect tires periodically and pay extra attention to the following:

- Check for punctures or holes. Ensure they do not exceed a diameter of 2.54 cm (1 in).

### **WARNING**

**If any tire does not meet the criteria outlined above, remove telehandler from service and replace wheel/tire immediately.**

### **WARNING**

**Do not use tires other than those specified for this machine. Do not mix different types of tires. Tires other than those specified can adversely affect stability. Failure to operate with matched, approved tires in good condition can result in death or serious injury. Replace tires with exact, Skyjack-approved types only.**

#### ❻ **Drive Axles - A**

- Ensure drive axles are properly secured, there are no loose or missing parts, all fittings and hoses are properly tightened and there is no evidence of oil leakage.
- Check the brakes annually. Refer to section 5.

#### ❼ **Steer Cylinder - A**

- Ensure steer cylinders are properly secured, there are no loose or missing parts, all fittings and hoses are properly tightened and there is no evidence of hydraulic oil leakage.

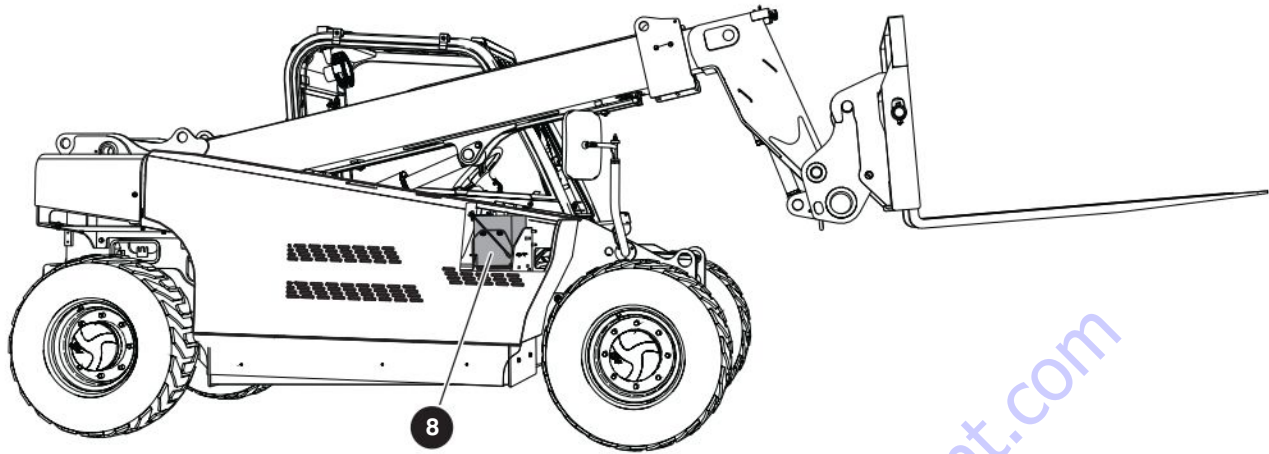

### 8 Battery - A

Proper battery condition is essential to good engine performance and operational safety. Improper fluid levels or damaged cables and connections can result in engine component damage and hazardous conditions.

### **⚠ WARNING**

**Battery acid is extremely corrosive. Wear proper eye and facial protection as well as appropriate protective clothing. If contact occurs, immediately flush with cold water and seek medical attention.**

1. Check battery case for damage.
2. Clean battery terminals and cable ends thoroughly with a terminal cleaning tool or wire brush.
3. Ensure all battery connections are tight.
4. If applicable, check battery fluid level. If plates are not covered by at least 13 mm (1/2 in) of solution, add distilled or demineralized water.
5. Replace battery if damaged or incapable of holding a lasting charge.

### **⚠ WARNING**

**Use original or manufacturer-approved parts and components for the telehandler.**

### **⚠ WARNING**



**Explosion hazard. Keep flames and sparks away. Do not smoke near batteries.**



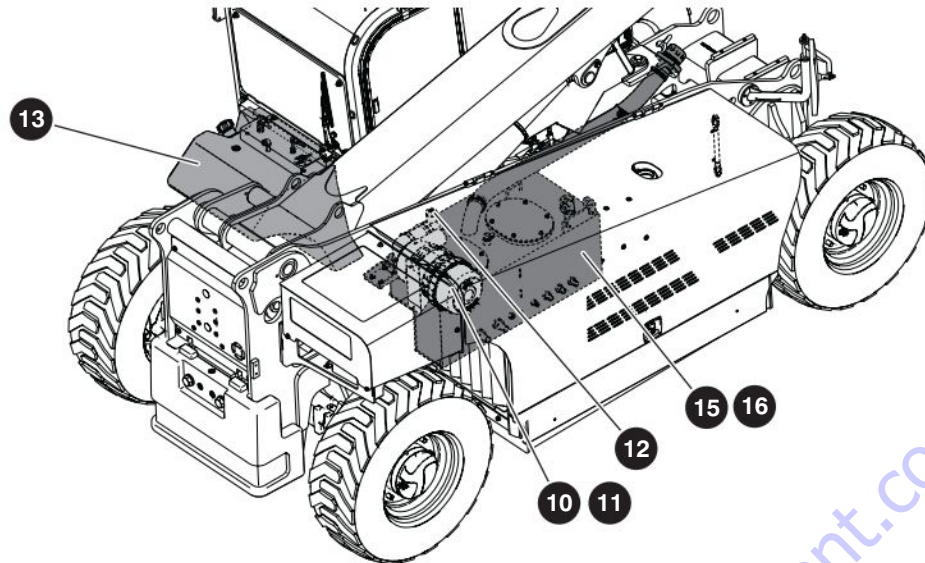

### 10 Engine Intake Air Filter - A

- Ensure there are no loose or missing parts and there is no visible damage.
- Ensure **air cleaner vacuator valve** 11 is free from dirt or dust by squeezing the valve lips.
- Check **air cleaner service indicator** 12 and replace filter element if needed.

### 13 Fuel Tank - A

## IMPORTANT

Before using your telehandler ensure there is enough fuel for expected use.

- Ensure fuel filler cap is secure.
- Ensure tank shows no visible damage and no evidence of fuel leakage.
- **Fuel Leaks - A**  
Failure to detect and correct fuel leaks will result in an unsafe condition. An explosion or fuel fire may cause death or serious injury. Perform a visual inspection around the following areas:
  - hoses and fittings
  - fuel pump
  - fuel filter
  - fuel tank
- Be sure to follow all local, provincial/territorial/state and national regulations related to disposing of fluids and soiled rags, cloths, etc.

## WARNING

Engine fuels are combustible. Inspect the telehandler in an open, well-ventilated area away from heaters, sparks and flames. Always have an approved fire extinguisher within easy reach.

### 15 Hydraulic Oil Tank

- Ensure hydraulic filler cap is secure.
- Ensure tank shows no visible damage and no evidence of hydraulic leakage.

### 16 Hydraulic Oil - A, D

- Be sure that the boom is in the lowered and stowed position, and then visually inspect the sight gauge located in the front of the machine behind the left front wheel.
- Add fresh, clean hydraulic oil as required. Refer to [Section 2.4](#) for recommended oil type.
- Be sure to follow all local, provincial/territorial/state and national regulations related to disposing of fluids and soiled rags, cloths, etc.

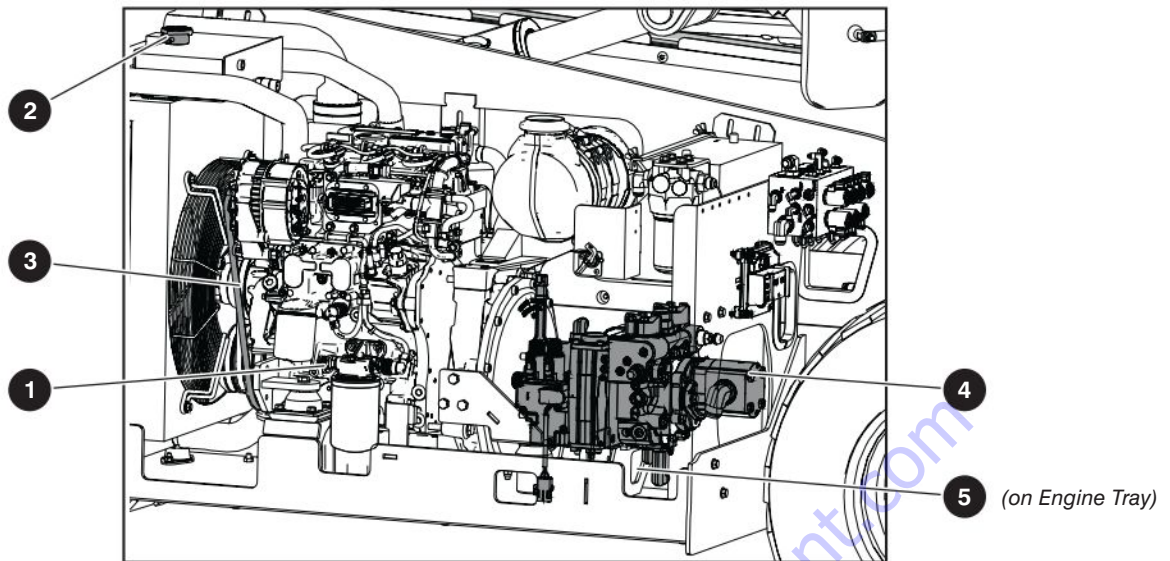

### 1.5-7 Engine Compartment

- Ensure compartment cover is secure and in proper working order.

#### **⚠ WARNING**

**Beware of hot engine components.**

- Engine Oil Level on Dipstick** - **A, C**  
Maintaining the engine components is essential to good performance and service life of the telehandler.
  - Oil level should be between the L (low) and H (high) marks. Add oil as needed. Refer to [Section 2.4](#) for recommended oil type.
- Engine Coolant** - **A**

#### **⚠ WARNING**

**Pressurized fluid present in radiator. Never open radiator cap when hot.**

- Check coolant level on radiator.
  - Add coolant as required.
  - Be sure to follow all local, provincial/territorial/state and national regulations related to disposing of fluids and soiled rags, cloths, etc.
- Belts - A**
    - Ensure belts are in good working condition and have correct tension. Replace if belts are cracked, frayed, or have chunks of material missing. Refer to service manual for proper replacement procedure.

- Hydraulic Oil Pump - A**

- Ensure there are no loose or missing parts and there is no visible damage.
- Ensure all bolts are properly tightened.
- Ensure all fittings and hoses are properly tightened and there is no evidence of hydraulic oil leakage.

- Fuel/Water Separator** - **C, D**

- Ensure there are no loose or missing parts and there is no visible damage.
- Ensure all fittings and hoses are properly tightened and there is no evidence of fuel leaks.
- Drain water by opening water drain plug at bottom of filter. Close tightly after inspection.

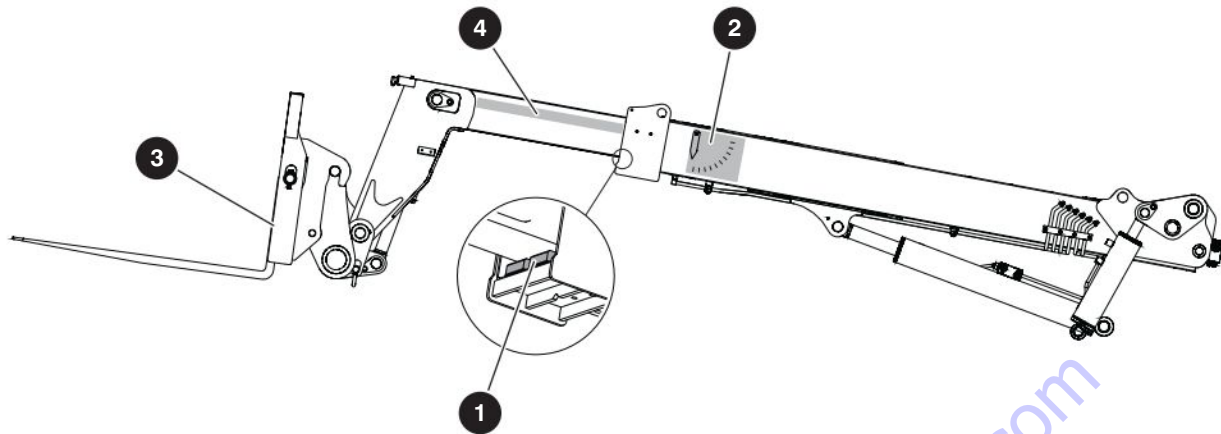

### 1.5-8 Boom - A

- Ensure there are no loose or missing parts and there is no visible damage.
- Ensure all bolts and pins are properly tightened.
- Ensure there are no visible cracks in welds or structure and there are no signs of deformation.
- Ensure all hoses are properly tightened and there is no evidence of hydraulic leakage.

#### 1 Slide Pads - B, C, D

- Ensure all bolts are tight, there is no visible damage to the slide pads and that no parts are missing.

#### 2 Boom Angle Indicator - A

- Ensure all bolts are tight, and there is no visible damage and indicator swings freely.

### 1.5-9 Lifting Attachment - A

- 3 Ensure attachment is properly positioned and secured.
  - Ensure there are no loose or missing parts and there is no visible damage.

### 1.5-10 Grease Points - B

Maintaining properly greased components is essential for good performance and service life of the telehandler. If components are improperly greased, it could result in component damage.

- 4 Greased component locations

#### **WARNING**

**Ensure that there are no personnel or obstructions in maintenance area.**

Greasing intervals are based on average telehandler usage. Use of telehandler may vary significantly and greasing frequency must be adjusted to obtain maximum service life.

Refer to the Daily & Weekly Maintenance Chart located inside operator's cab for grease points location and service intervals.

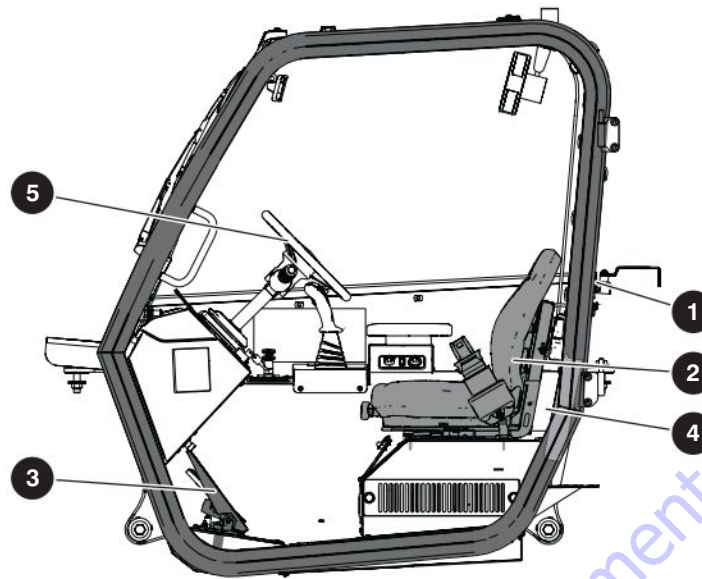

### 1.5-11 Operator's Cab

#### 1 Rollover and Falling Object Protective Structure (ROPS/FOPS)

- Ensure there is no visible damage.

#### **⚠ WARNING**

Do not modify, drill or alter the operator's cab in any way.

#### 2 Seat - A

- Ensure seat is properly secured with no visible damage.
- Ensure seat belt is working properly with no visible damage.

#### 3 Pedals - A

- Ensure brake and accelerator pedals are secure, no loose or missing parts, no visible damage and movements are not obstructed.

#### 4 Manual - A

- Check to be sure manual storage box is present and in good condition.
- Ensure a copy of operating manual, and other important documentation are enclosed in manual storage box.
- Ensure manual is legible and in good condition.
- Always return manual to the manual storage box after use.

#### 5 Tilt Steering (If Equipped) - A

- Ensure steering wheel is properly secured with no visible damage.
- Ensure the tilt steering mechanism is working properly with no visible damage.

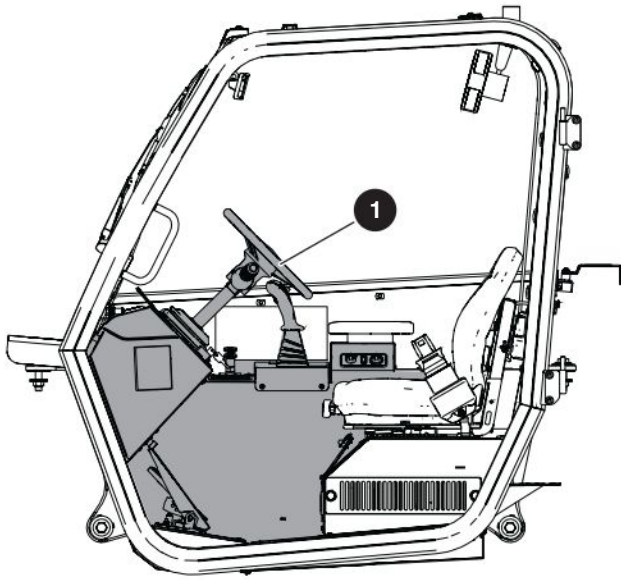

## 1.5-12 Operator's Cab Controls

### **WARNING**

Ensure that you maintain three points of contact to mount/dismount the cab.

- Use the steps of telehandler to access operator's cab.
- Ensure door and windows (if equipped) are secure and in proper working order.
- Ensure **operator's cab controls** ① are secured with no visible damage.
- Ensure **multi-functional joystick** ② is secured, movements are not obstructed and, with no visible damage.
- Ensure **operator's dash controls** ③ are properly secured, returned to their neutral position, with no visible damage.
- Ensure **capacity charts** ④ are in place and are legible.

### **WARNING**

Do not operate the telehandler if capacity charts are missing or not legible.

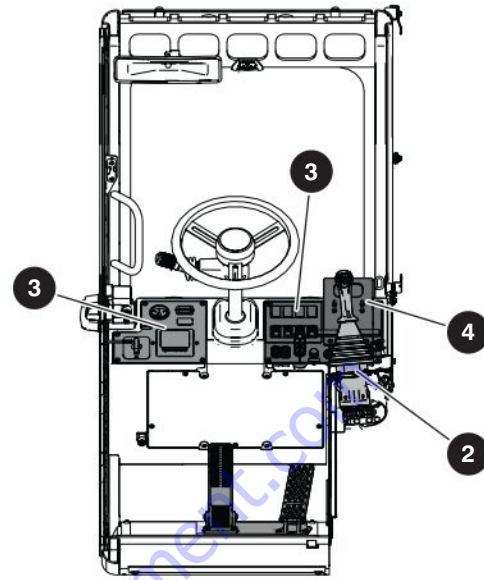

## 1.6 Function Tests

Function tests are designed to discover any malfunctions before the Telehandler is put into service. The operator must understand and follow step-by-step instructions to test all Telehandler functions.

### **IMPORTANT**

**Never use a malfunctioning Telehandler. If malfunctions are discovered, Telehandler must be tagged and placed out of service. Repairs to Telehandler may only be made by a qualified service technician.**

- After repairs are completed, operator must perform a pre-operation inspection and a series of function tests again before putting Telehandler into service.
- Prior to performing function tests, be sure to read and understand the "Start Operation" section of the operating manual.
- For function test that are to be performed, please refer to the operating manual that corresponds to the correct serial number. Found there will be detailed instructions for which tests to perform, as well as how to properly and successfully perform them.



### **NOTE**

*All-function motion alarm should sound while operating any boom and drive function*

To order go to [Discount-Equipment.com](http://Discount-Equipment.com)

---

# Section 2 – Maintenance Tables

To order go to [Discount-Equipment.com](http://Discount-Equipment.com)

**Table 2.1 Standard and Optional Equipment**

<b>MODEL</b>	<b>SJ519 TH</b>
<b>Standard Equipment</b>	
122 cm (48 in) Standard Carriage	*
Air Filled Tires	*
Diesel Engine	*
Four-wheel drive	*
Lifting Hook	*
Open Operator's Cab	*
Operator horn	*
Reverse/Backup Alarm	*
Spring-applied Hydraulically Released Parking Brake	*
Single-Speed Hydrostatic Transmisson	*
Three-Mode Steering	*
Rear Hitch	*
<b>Optional Equipment</b>	
Tilt Steering	*
0.38 m <sup>3</sup> (0.50 Cu. Yd.) 167.64 cm (66 in) Bucket Loader Attachment	*
183 cm (6 ft) Truss Boom Attachment	*
Skid Steer Adaptor Attachment	*
122 cm (48 in) Side-Tilt Fork Carriage	*
122 cm (48 in) Side Shift Fork Carriage	*
Back-up Sensor/ Back-up Camera and Sensor	*
Enclosed Operator's Cab	*
Enclosed Operator's Cab with A/C	*
Fire Extinguisher	*
Flashing Beacon	*
Foam Filled Tires	*
Solid Black Rubber Tires	*
Solid Non Marking Tires	*
Air / Foam Non Marking Tires	*
Air / Foam Wearmaster Tires	*
Four-Wheel Fenders	*
Positive Air Shut-off System	*
Road/Work/Boom Lights	*
Speed Limiter Control	*
Service Convenience Package	*
Partially Enclosed Cab	*
Hydraulic Quick Coupler	*

1691AA



**Table 2.2 Specifications and Features**

MODEL		SJ519 TH
<b>Standard Engine</b>		
Type	Deutz TCD 2.2 L T4	
Cylinders	3	
Horsepower @ 2600 RPM	74 HP	
Capacity	2.2 L	
Torque @ 1600 RPM	280 N•m (206.5 lbf•ft)	
Idle Speed*	1200 rpm	
Fuel type	Diesel	
<b>Transmission</b>		
Hydrostatic	Speed forward / Reverse	Hydrostatic (Variable)
<b>Travel Speed</b>		
Hydrostatic	23 km/h (14.5 mph)	
<b>Electrical</b>		
Negative ground	12 Volts	
Alternator	120 Amps	
Battery	925 CCA	
Backup Alarm	107 DBA	
<b>Dimensions</b>		
Wheelbase	245.11 cm (8 ft 0.5 in)	
Overall width	182.88 cm (6 ft)	
Overall height (stowed)	193.04 cm (6 ft 4 in)	
Overall length (stowed, less forks)	408.94 cm (13 ft 5 in)	
Ground clearance	24.13 cm (9.5 in)	
Maximum weight without attachment	10,255 lb	
Turn radius (inside) (4WS)	134.62 cm (53 in)	
Turn radius (outside) (4WS)	317.50 cm (125 in)	
<b>Boom</b>		
Number of sections	2	
Maximum lift height	5.82 m (19 ft 1 in)	
Maximum forward reach	3.38 m (11 ft 1 in)	
Standard Forks (Standard Tapered Forks)	4 cm x 10 cm x 122 cm (1.57 in x 3.94 in x 48 in)	
Carriage rollback @ Maximum Boom Angle (Top)	88°	
Carriage forward tilt @ Maximum Boom Angle (Bottom)	40°	
<b>Towing Capacity</b>		
Towing Weight (MAX)	2,268 kg (5,000 lb)	
Towing Tongue Weight (MAX)	340 kg (750 lb)	

\* Engine Idle Speed is measured with 5% droop when in gear.

1692AA

**Table 2.3 Tire/Wheel Specifications**

<b>Model SJ519 TH</b>					
	FILL	Size	Pressure	"Ply Rating"	"Wheel Nuts Torque"
BLACKSTONE OTR	AIR	26.7 cm x 44.5 cm (12.00 in x 16.5 in)	552 Kpa (80 psi)	12	" 372.85 N•m (275 lbf•ft)"
	FOAM		N/A		
	NON MARKING AIR		552 Kpa (80 psi)		
	NON MARKING FOAM		N/A		
WEARMASTER OTR	AIR		552 Kpa (80 psi)		
	FOAM		N/A		
SOLIDBOSS	BLACK RUBBER	83.8 cm x 30.5 cm (33 in x 12 in)	N/A	20	
	NON MARKING		N/A		

1694AA

** WARNING**

Do not use tires other than those specified for this machine. Do not mix different types of tires. Tires other than those specified can adversely affect stability. Failure to operate with matched, approved tires in good condition can result in serious injury or even death. Replace tires with the exact, Skyjack-approved types only.

**IMPORTANT**

For proper function of each axle differential, all four wheels must have same tire size installed at all times. Failure to comply with this requirement reduces the life of the differentials and reduce overall mobility of telehandler.

**Table 2.4 Recommended Fluids/Lubrications**

<b>Model SJ519 TH</b>		
<b>Engine</b>		
Fuel Type	Ultra Low Sulfur Diesel (EN 590, ASTM D975) or Biodiesel B20	
Fuel Tank Capacity	57 L (15.1 gal)	
Recommended Oil Type	SAE 15W40	
Engine Oil Capacity	8.5 L (9 Quart)	
Coolant Type (Standard)	COOLANT-ANTIFREEZE 50/50 PREMIX *	
Coolant Type (Cold Weather Option)	COOLANT-ANTIFREEZE 60/40 PREMIX *	
Coolant Tank Capacity	12 L (3.2 gal)	
<b>Transmission</b>		
Hydrostatic	Oil Type	ATF Dexron 3
<b>Axles</b>		
Differential	API GL5 LS	
Front Gear Box Capacity	0.7 L (0.74 Quart)	
Front Central House Capacity	4.0 L (4.2 Quart)	
Rear Central House Capacity		
Front Wheel Hub Capacity	0.9 + 0.9 L (0.95 + 0.95 Quart)	
Rear Wheel Hub Capacity	0.9 + 0.9 L (0.95 + 0.95 Quart)	
<b>Hydraulic Oil</b>		
Standard Factory Fill	ATF Dexron III	
Type	ATF Dexron III or equivalent	
Hydraulic Tank Capacity	70 L (18.5 gal)	
<b>Grease Points</b>		
Type	EP2 Grease	

\* Refer to engine manufacturer's manual

1693AB

**⚠ WARNING**

**Do not mix hydraulic oil of different types or use oils of types other than those originally supplied with this equipment. Doing so can severely damage hydraulic components. A full hydraulic oil system flush must be performed prior to adding a new type of hydraulic oil. Consult Skyjack service department.**

## Table 2.5 Pressure Setting

Model SJ519 TH		
System Component	Test Port	Pressure Valve
Pilot Oil Pressure	GP1	Item
Tilt Comp./ Carriage Tilt Port Relief	GP3	3500 psi
System		
Maximum Pressure	GP3	3900 psi
Steering & Brakes		
Steering Maximum	GP2	2000 psi
Brakes Maximum	GP2	1000 psi

1721AA



**NOTE**

All pressures to be checked with engine running at idle unless specified otherwise.



**NOTE**

Service brake pressure is variable. The value provided above is the maximum nominal value.

To order go to Discount-Equipment.com

## Table 2.6 Standard Hose Numbering System

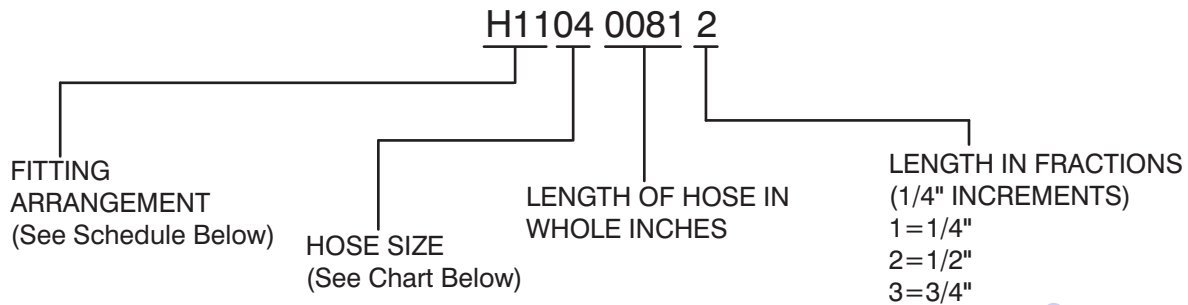

Using the number above as an example, H1104 0081 2, this hose requires a 37° JIC female swivel fitting on one end, and a medium length 90° JIC female swivel fitting for the other end. The hose must meet or exceed the S.A.E. 100R13 hose specification, and be a total of 81-1/2" long.



### NOTE

Hose ends and hose must be from same manufacturer per S.A.E. J1273 Nov. '91, Sections 3.10 and 4.2. Hose ends and hose must be of the same size i.e. #4 size fittings must be used with #4 size hose.

#### Hose Size Chart

Size	03	04	06	08	10	12	16	20	24	32	40	48	56	64
ID	3/16"	1/4"	3/8"	1/2"	5/8"	3/4"	1"	1-1/4"	1-1/2"	2"	2-1/2"	3"	3-1/2"	4"

#### Fitting Arrangement Schedule

Hose Prefix	Hose End Fitting	Hose End Fitting	S.A.E. Hose Specification
H01	FEMALE, 37° JIC, SWIVEL	FEMALE, 37° JIC, SWIVEL	100R17
H02	FEMALE, 37° JIC, SWIVEL	FEMALE, 37° JIC, SWIVEL	100R13
H03	FEMALE, 37° JIC, SWIVEL	45°, FEMALE, 37° JIC, SWIVEL	100R17
H04	FEMALE, 37° JIC, SWIVEL	45°, FEMALE, 37° JIC, SWIVEL	100R13
H05	FEMALE, 37° JIC, SWIVEL	LONG 90°, FEMALE, 37° JIC, SWIVEL	100R17
H06	FEMALE, 37° JIC, SWIVEL	SHORT 90°, FEMALE, 37° JIC, SWIVEL	100R17
H07	LONG 90°, FEMALE, 37° JIC, SWIVEL	LONG 90°, FEMALE, 37° JIC, SWIVEL	100R17
H08	FEMALE, 37° JIC, SWIVEL	FEMALE, 37° JIC, SWIVEL	100R4
H09	FEMALE, 37° JIC, SWIVEL	45°, FEMALE, 37° JIC, SWIVEL	100R4
H10	FEMALE, 37° JIC, SWIVEL	MALE PIPE THREAD FITTING	100R17
H11	FEMALE, 37° JIC, SWIVEL	MEDIUM 90°, FEMALE, 37° JIC, SWIVEL	100R13
H12	SHORT 90°, FEMALE, 37° JIC, SWIVEL	SHORT 90°, FEMALE, 37° JIC, SWIVEL	100R17
H13	FEMALE, 37° JIC, SWIVEL	REUSABLE MALE PIPE THREAD FITTING	300 PSI
H14	REUSABLE MALE PIPE THREAD FITTING	NO FITTING	300 PSI
H15	REUSABLE FEMALE, 37° JIC, SWIVEL	REUSABLE FEMALE, 37° JIC, SWIVEL	300 PSI
H16	NO FITTING	NO FITTING	100R4
H17	NO FITTING	NO FITTING	300 PSI
H18	REUSABLE, FEMALE, 37° JIC, SWIVEL	NO FITTING	300 PSI
H19	LONG 90°, FEMALE, 37° JIC, SWIVEL	FEMALE, 37° JIC, SWIVEL	100R13
H20	FEMALE, SHORT 37° JIC, SWIVEL	SHORT 90°, FEMALE, 37° JIC, SWIVEL	100R4

### Fitting Arrangement Schedule

Hose Prefix	Hose End Fitting	Hose End Fitting	S.A.E. Hose Specification
H21	FEMALE, SHORT 37° JIC, SWIVEL	SHORT 90°, FEMALE, 37° JIC, SWIVEL	100R2AT
H22	FEMALE, 37° JIC, SWIVEL	FEMALE, 37° JIC, SWIVEL	100R2AT
H23	FEMALE, LONG 37° JIC, SWIVEL	LONG 90°, FEMALE, 37° JIC, SWIVEL	100R2AT
H24	FEMALE, SHORT 37° JIC, SWIVEL	SHORT 90°, FEMALE, 37° JIC, SWIVEL	100R13
H25	FEMALE, 37° JIC, SWIVEL	FEMALE, 37° JIC, SWIVEL	100R4
H30	MEDIUM 90°, FEMALE, 37° JIC, SWIVEL	FEMALE, 37° JIC, SWIVEL	100R17
H31	FEMALE, 37° JIC, SWIVEL	FEMALE, 37° JIC, SWIVEL	100R17
H32	SHORT 45°, FEMALE, 37° JIC, SWIVEL	FEMALE, 37° JIC, SWIVEL	100R17
H33	MEDIUM 45°, FEMALE, 37° JIC, SWIVEL	FEMALE, 37° JIC, SWIVEL	100R17
H34	SHORT 90°, FEMALE, 37° JIC, SWIVEL	FEMALE, 37° JIC, SWIVEL	100R17
H35	MEDIUM 90°, FEMALE, 37° JIC, SWIVEL	FEMALE, 37° JIC, SWIVEL	100R17
H36	LONG 90°, FEMALE, 37° JIC, SWIVEL	FEMALE, 37° JIC, SWIVEL	100R17
H37	SHORT 45°, FEMALE, 37° JIC, SWIVEL	FEMALE, 37° JIC, SWIVEL	100R4
H38	SHORT 90°, FEMALE, 37° JIC, SWIVEL	FEMALE, 37° JIC, SWIVEL	100R4
H39	LONG 90°, FEMALE, 37° JIC, SWIVEL	FEMALE, 37° JIC, SWIVEL	100R4
H40	SHORT 90°, FEMALE, 37° JIC, SWIVEL	FEMALE, 37° JIC, SWIVEL	100R16
H43	FEMALE, 37° JIC, SWIVEL	FEMALE, 37° JIC, SWIVEL	100R16
H51	FEMALE, 37° JIC, SWIVEL	FEMALE, 37° JIC, SWIVEL	100R17
H52	SHORT 45°, FEMALE, 37° JIC, SWIVEL	FEMALE, 37° JIC, SWIVEL	100R17
H53	MEDIUM 45°, FEMALE, 37° JIC, SWIVEL	FEMALE, 37° JIC, SWIVEL	100R17
H54	SHORT 90°, FEMALE, 37° JIC, SWIVEL	FEMALE, 37° JIC, SWIVEL	100R17
H55	MEDIUM 90°, FEMALE, 37° JIC, SWIVEL	FEMALE, 37° JIC, SWIVEL	100R17
H56	LONG 90°, FEMALE, 37° JIC, SWIVEL	FEMALE, 37° JIC, SWIVEL	100R17
H57	SHORT 45°, FEMALE, SAE ORFS, SWIVEL	FEMALE, SAE ORFS, SWIVEL	100R13
H58	FEMALE, SAE ORFS, SWIVEL	FEMALE, SAE ORFS, SWIVEL	100R13
H59	MEDIUM 90°, FEMALE, SAE ORFS, SWIVEL	FEMALE, SAE ORFS, SWIVEL	100R13
H60	FEMALE, 37° JIC, SWIVEL	FEMALE, 37° JIC, SWIVEL	100R17
H61	FEMALE, 37° JIC, SWIVEL	FEMALE, 37° JIC, SWIVEL	100R16
H62	SHORT 90°, FEMALE, 37° JIC, SWIVEL	FEMALE, 37° JIC, SWIVEL	100R16
H63	MEDIUM 90°, FEMALE, 37° JIC, SWIVEL	FEMALE, 37° JIC, SWIVEL	100R16
H64	LONG 90°, FEMALE, 37° JIC, SWIVEL	FEMALE, 37° JIC, SWIVEL	100R16
H65	MEDIUM 67°, FEMALE, 37° JIC, SWIVEL	FEMALE, 37° JIC, SWIVEL	100R12
H66	FEMALE, 37° JIC, SWIVEL	NO FITTING	100R4
H67	FEMALE, 37° JIC, SWIVEL	FEMALE, 37° JIC, SWIVEL	100R19
H68	SHORT 45°, FEMALE, 37° JIC, SWIVEL	FEMALE, 37° JIC, SWIVEL	100R19
H69	MEDIUM 90°, FEMALE, 37° JIC, SWIVEL	FEMALE, 37° JIC, SWIVEL	100R19
H70	LONG 90°, FEMALE, 37° JIC, SWIVEL	FEMALE, 37° JIC, SWIVEL	100R19
H71	LONG 90°, FEMALE, SAE ORFS, SWIVEL	FEMALE, SAE ORFS, SWIVEL	100R15

## Table 2.7 Torque Specifications for Fasteners (US)

Size	Torque Type	SAE2		SAE 5		SAE 8	
		Dry	Lubed	Dry	Lubed	Dry	Lubed
4-40	(in-lb)	(5)	(4)	(8)	(6)	(12)	(9)
	Nm	0.6	0.5	0.9	0.7	1.4	1.0
4-48	(in-lb)	(6)	(5)	(9)	(7)	(13)	(10)
	Nm	0.7	0.6	1.0	0.8	1.5	1.1
6-32	(in-lb)	(10)	(8)	(16)	(12)	(23)	(17)
	Nm	1.1	0.9	1.8	1.4	2.6	1.9
6-40	(in-lb)	(12)	(9)	(18)	(13)	(25)	(19)
	Nm	1.4	1.0	2.0	1.5	2.8	2.1
8-32	(in-lb)	(19)	(14)	(30)	(22)	(41)	(31)
	Nm	2.1	1.6	3.4	2.5	4.6	3.5
8-36	(in-lb)	(20)	(15)	(31)	(23)	(43)	(32)
	Nm	2.3	1.7	3.5	2.6	4.9	3.6
10-24	(in-lb)	(27)	(21)	(43)	(32)	(60)	(45)
	Nm	3.1	2.4	4.9	3.6	6.8	5.1
10-32	(in-lb)	(31)	(23)	(49)	(36)	(68)	(51)
	Nm	3.5	2.6	5.5	4.1	7.7	5.8
1/4-20	(in-lb) ft-lb	(66)	(50)	8	(75)	12	9
	Nm	7.5	5.6	11	8.5	16	12
1/4-28	(in-lb) ft-lb	(76)	(56)	10	(86)	14	10
	Nm	8.6	6.3	14	9.7	19	14
5/16-18	ft-lb	11	8	17	13	25	18
	Nm	15	11	23	18	34	24
5/16-24	ft-lb	12	9	19	14	25	20
	Nm	16	12	26	19	34	27
3/8-16	ft-lb	20	15	30	23	45	35
	Nm	27	20	41	31	61	47
3/8-24	ft-lb	23	17	35	25	50	35
	Nm	31	23	47	34	68	47
7/16-14	ft-lb	32	24	50	35	70	55
	Nm	43	33	68	47	95	75
7/16-20	ft-lb	36	27	55	40	80	60
	Nm	49	37	75	54	108	81
1/2-13	ft-lb	50	35	75	55	110	80
	Nm	68	47	102	75	149	108
1/2-20	ft-lb	55	40	90	65	120	90
	Nm	75	54	122	88	163	122

Size	Torque Type	SAE2		SAE 5		SAE 8	
		Dry	Lubed	Dry	Lubed	Dry	Lubed
9/16-12	ft-lb	70	55	110	80	150	110
	Nm	95	75	149	108	203	149
9/16-18	ft-lb	80	60	120	90	170	130
	Nm	108	81	163	122	230	176
5/8-11	ft-lb	100	75	150	110	220	170
	Nm	136	102	203	149	298	230
5/8-18	ft-lb	110	85	180	130	240	180
	Nm	149	115	244	176	325	244
3/4-10	ft-lb	175	130	260	200	380	280
	Nm	237	176	353	271	515	380
3/4-16	ft-lb	200	150	300	220	420	320
	Nm	271	203	407	298	569	434
7/8-9	ft-lb	170	125	430	320	600	460
	Nm	230	169	583	434	813	624
7/8-14	ft-lb	180	140	470	360	660	500
	Nm	244	190	637	488	895	678
1-8	ft-lb	250	190	640	480	900	680
	Nm	339	258	868	651	1220	922
1-12	ft-lb	270	210	710	530	1000	740
	Nm	366	285	963	719	1356	1003
1-14	ft-lb	280	210	730	540	1020	760
	Nm	380	285	990	732	1383	1030
1 1/8-7	ft-lb	350	270	800	600	1280	960
	Nm	475	366	1085	813	1735	1302
1 1/8-12	ft-lb	400	300	880	660	1440	1080
	Nm	542	407	1193	895	1952	1464
1 1/4-7	ft-lb	500	380	1120	840	1820	1360
	Nm	678	515	1519	1139	2468	1844
1 1/4-12	ft-lb	550	420	1240	920	2000	1500
	Nm	746	569	1681	1247	2712	2034
1 3/8-6	ft-lb	670	490	1460	1100	2380	1780
	Nm	908	664	1979	1491	3227	2413
1 3/8-12	ft-lb	750	560	1680	1260	2720	2040
	Nm	1017	759	2278	1708	3688	2766
1 1/2-6	ft-lb	870	650	1940	1460	3160	2360
	Nm	1180	881	2630	1979	4284	3200
1 1/2-12	ft-lb	980	730	2200	1640	3560	2660
	Nm	1329	990	2983	2224	4827	3606

**NOTE:** Lubed includes lubricants such as lubrizing, oil, grease, or uncured Loctite.

1374AA

**Table 2.8 Torque Specifications for Fasteners (Metric)**

Size	Torque Type	SAE 2		SAE 5		SAE 8	
		Dry	Lubed	Dry	Lubed	Dry	Lubed
M5 x 0.80	(in-lb)	(54)	(41)	(78)	(59)	(12)	(9)
	Nm	6.1	4.6	8.8	6.7	1.4	1.0
M6 x 1.00	(in-lb)	(92)	(69)	(133)	(99)	(13)	(10)
	Nm	10.4	7.8	15	11.2	1.5	1.1
M7 x 1.00	(in-lb)	(156)	(116)	(222)	(167)	(23)	(17)
	Nm	17.6	13.1	25.1	18.9	2.6	1.9
M8 x 1.25	(in-lb)	(225)	(169)	(333)	(242)	(25)	(19)
	Nm	25.4	19.1	37.6	27.3	2.8	2.1
M10 x 1.50	ft-lb	37	28	53	40	(41)	(31)
	Nm	50	38	72	54	4.6	3.5
M12 x 1.75	ft-lb	65	49	93	69	(43)	(32)
	Nm	88	66	126	94	4.9	3.6
M14 x 2.00	ft-lb	104	78	148	111	(60)	(45)
	Nm	141	106	201	150	6.8	5.1
M16 x 2.00	ft-lb	161	121	230	172	(68)	(51)
	Nm	218	164	312	233	7.7	5.8
M18 x 2.50	ft-lb	222	167	318	238	12	9
	Nm	301	226	431	323	16	12
M20 x 2.50	ft-lb	314	235	449	337	14	10
	Nm	426	319	609	457	19	14
M22 x 2.50	ft-lb	428	321	613	460	25	18
	Nm	580	435	831	624	34	24
M24 x 3.00	ft-lb	543	407	776	582	25	20
	Nm	736	552	1052	789	34	27
M27 x 3.00	ft-lb	796	597	1139	854	45	35
	Nm	1079	809	1544	1158	61	47
M30 x 3.50	ft-lb	1079	809	1543	1158	50	35
	Nm	1463	1097	2092	1570	68	47
M33 x 3.50	ft-lb	1468	1101	2101	1576	70	55
	Nm	1990	1493	2849	2137	95	75
M36 x 4.00	ft-lb	1886	1415	2699	2024	80	60
	Nm	2557	1918	3659	2744	108	81

**NOTE:** Lubed includes lubricants such as lubrizing, oil, grease, or uncured Loctite.

1375AA



**Table 2.9 Torque Specifications for Hydraulic Couplings & Hoses**

<b>Hydraulic Coupling Torque Chart O-Ring Port Connectors</b>				
<b>SAE Size</b>	<b>Steel Ports</b>		<b>Non-ferrous Ports</b>	
	<b>ft-lb</b>	<b>Nm</b>	<b>ft-lb</b>	<b>Nm</b>
4	14-16	20-22	9-10	12-13
6	24-26	33-35	15-16	20-21
8	50-60	68-78	30-36	41-47
10	72-80	98-110	43-48	60-66
12	125-135	170-183	75-81	102-110
16	200-220	270-300	120-132	162-180
20	210-280	285-380	126-168	171-228
24	270-360	370-490	162-216	222-294
32	-	-	-	-

<b>Hose End Torque Chart for JIC</b>									
<b>Size</b>		<b>Steel</b>				<b>Brass</b>			
<b>Dash</b>	<b>Frac.</b>	<b>ft-lb</b>		<b>Nm</b>		<b>ft-lb</b>		<b>Nm</b>	
		<b>Min.</b>	<b>Max.</b>	<b>Min.</b>	<b>Max.</b>	<b>Min.</b>	<b>Max.</b>	<b>Min.</b>	<b>Max.</b>
-4	1/4"	10	11	13	15	5	6	6.75	9
-6	3/8"	17	19	23	26	12	15	17	20
-8	1/2"	34	38	47	52	20	24	27.66	33
-10	5/8"	50	56	69	76	34	40	46.33	55
-12	3/4"	70	78	96	106	53	60	72.33	82
-16	1"	94	104	127	141	74	82	100.5	111
-20	1 1/4"	124	138	169	188	75	83	101.5	113
-24	1 1/2"	156	173	212	235	79	87	107	118
-32	2"	219	243	296	329	158	175	214	237

<b>Hose End Torque Chart for Flat-Face O-Ring Seal (Steel)</b>					
<b>Size</b>		<b>Torque Specification</b>			
<b>Dash</b>	<b>Frac.</b>	<b>ft-lb</b>		<b>Nm</b>	
		<b>Min.</b>	<b>Max.</b>	<b>Min.</b>	<b>Max.</b>
-4	1/4"	10	12	14	16
-6	3/8"	18	20	24	27
-8	1/2"	32	40	43	54
-10	5/8"	46	56	60	75
-12	3/4"	65	80	90	110
-14	1"	65	80	90	110
-16	1 1/4"	92	105	125	240
-20	1 1/2"	125	140	170	190
-24	2"	150	180	200	245









































1276AA

---



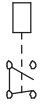
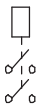
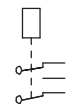

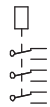



















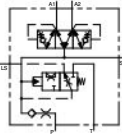



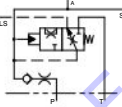







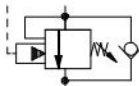

## Section 3 – System Component Identification and Schematics

To order go to [Discount-Equipment.com](http://Discount-Equipment.com)

**Table 3.1 Electrical Symbol Chart**

 CIRCUITS CROSSING NO CONNECTION	 HOURMETER	 KEY SWITCH	 LIMIT SWITCH N.O.
 CIRCUITS CONNECTED	 LIGHT	 FOOT SWITCH	 LIMIT SWITCH N.O. HELD CLOSED
 BATTERY	 HYDRAULIC VALVE COIL	 TOGGLE SWITCH	 LIMIT SWITCH N.C.
 GROUND	 PROPORTIONAL HYDRAULIC VALVE COIL	 PUSH BUTTON	 LIMIT SWITCH N.C. HELD OPEN
 FUSE	 ELECTRIC MOTOR	 ROTARY SWITCH	 SILICON CONTROLLED RECTIFIER
 CIRCUIT BREAKER	 HORN	 LIMIT SWITCH	 PROXIMITY SWITCH
 VOLT METER	 EMERGENCY STOP BUTTON	 CAM OPERATED LIMIT SWITCH	 PNP TRANSISTOR
 CAPACITOR	 RESISTOR	 TILT SWITCH	 NPN TRANSISTOR
 POTENTIOMETER	 LEVEL SENSOR	 SINGLE POLE SINGLE THROW RELAY	 PRESSURE/ VACUUM SWITCH
 SINGLE POLE DOUBLE THROW RELAY	 DOUBLE POLE SINGLE THROW RELAY	 DOUBLE POLE DOUBLE THROW RELAY	 TEMPERATURE SWITCH
 TRIPLE POLE DOUBLE THROW RELAY	 DIODE	 RHEOSTAT	

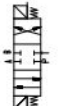
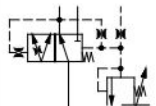
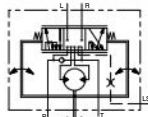
**Table 3.2 Hydraulic Symbol Chart**

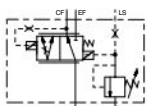
	LINE CROSSING		HAND PUMP		ACCUMULATOR, GAS CHARGED		SINGLE ACTING CYLINDER
	LINE JOINED		RELIEF VALVE		PRESSURE SWITCH		DOUBLE ACTING CYLINDER
	HYDRAULIC TANK		PRESSURE REDUCING VALVE		SHUTTLE VALVE		DOUBLE ACTING DOUBLE RODDED CYLINDER
	HYDRAULIC FILTER WITH BYPASS		FIXED ORIFICE		CHARGE VALVE DUAL		SPRING APPLIED HYDRAULIC RELEASED BRAKE
	ELECTRIC MOTOR		ADJUSTABLE FLOW CONTROL		CHARGE VALVE SINGLE		BRAKE CYLINDER
	ENGINE		CHECK VALVE		THREE POSITION SIX WAY OPEN CENTER CLOSED PORT		TWO POSITION TWO WAY NORMALLY OPEN VALVE
	FIXED DISPLACEMENT PUMP		OIL COOLER		COUNTER BALANCE VALVE		MAIN LINES Solid
	VARIABLE DISPLACEMENT PUMP		TWO POSITION THREE WAY VALVE		VALVE COIL		PILOT LINES Dashed
	VARIABLE DISPLACEMENT HYDRAULIC MOTOR		TWO POSITION TWO WAY NORMALLY CLOSED VALVE		THREE POSITION FOUR WAY CLOSED CENTER OPEN PORT		
	BI DIRECTIONAL HYDRAULIC MOTOR		THREE POSITION FOUR WAY CLOSED CENTER CLOSED PORT		DYNAMIC SIGNAL PRIORITY VALVE		
	ORBITAL STEERING MOTOR		PRESSURE TRANSDUCER		STATIC SIGNAL PRIORITY VALVE		

### 3.3 Electrical Schematic Parts List

Index No.	Skyjack Part No.	Qty.	Description
05CR	9-931298	1	RELAY, Park brake release
11CR	9-165029	1	RELAY, Glow plug
224CR	9-931298	1	RELAY, Carriage enable
237CR	9-931298	1	RELAY, Aux hydraulic
245ACR	9-931298	1	RELAY, Quick coupler enable
250ACR	9-931298	1	RELAY, Left turn signal
251ACR	9-931298	1	RELAY, Right turn signal
255CR	9-931298	1	RELAY, Rear wiper
258CR	9-931298	1	RELAY, Front wiper
258ACR	9-931298	1	RELAY, Top wiper
272CR	9-931298	1	RELAY, Quick coupler/aux hyd disconnect
403ACR	9-931298	1	RELAY, Positive shutoff
5JCR	9-931298	1	RELAY, Brake lamp
56ACR	9-156200	1	RELAY, FUEL PUMP
57CCR	9-931298	1	RELAY, NEUTRAL ENABLE
60CR	9-921734	1	RELAY, POWER
77CR	9-931298	1	RELAY, ENGINE RUNNING
86CR	9-931298	1	RELAY, OIL COOLER FAN
26DCR	9-931298	1	RELAY, BRAKE
86BCR			RELAY, DRIVE OIL COOLER FAN
15CR	9-931298		RELAY, BACKUP ALARM
57BCR	9-931298	1	RELAY, STARTER INTERRUPT
F1	9-156203	1	FUSE, IGNITION/POWER RELAY - 10 A
F2	9-156203	1	FUSE, TRANS/B-U ALARM/PARK BRAKE - 10 A
F3	9-156202	1	FUSE, STEER SELECT/GAUGE - 5 A
F4	9-156202	1	FUSE, FRAME/CARRIAGE ENABLE - 5 A
F5	9-156203	1	FUSE, AUXILIARY HYDRAULICS/QUICK COUPLER - 10 A
F6	9-156202	1	FUSE, CONTINUOUS AUXILIARY HYDRAULICS - 5 A
F7	9-156203	1	FUSE, HORN/BEACON LIGHT - 10 A
F8	9-156204	1	FUSE, POWER PORT - 15 A
F9	9-206850	1	FUSE, OIL COOLER FAN - 40 A
F10	9-156202	1	FUSE, REAR WIPER - 5 A
F11	9-156203	1	FUSE, WORK LIGHTS 10 A
F12	9-156204	1	FUSE, ROAD LIGHTS 15 A
F13	9-156202	1	FUSE, TURN/HARZARD/BRAKE LIGHTS 5 A
F14	9-156203	1	FUSE, BOOM LIGHTS 10 A
F15	9-156203	1	FUSE, FRONT AND TOP WIPER - 10 A
F16	9-156164	1	FUSE, BLOWER - 30 A
F17	9-156202	1	FUSE, FAN/INT. LIGHT 5 A
F20	9-156203	1	FUSE, HEATER VALVE, A/C - 10 A
F25	9-156164	1	FUSE, ECM - 30 A
F26	9-121504	1	FUSE, FUEL PUMP
F27	9-165031	1	FUSE, GLOW PLUG
F28	9-206096	1	FUSE, HFX12M
F29	9-121504	1	LOAD PWR +

Index No.	Skyjack Part No.	Qty.	Description
SW1	9-119725	1	SWITCH, DISCONNECT
SW2	9-926721	1	SWITCH, IGNITION SWITCH
SW3	9-191454	1	SWITCH, PARK BRAKE
SW4	9-191457	1	SWITCH, STEER MODE
SW5		1	SWITCH, JOYSTICK, AUXILIARY HYDRAULICS
SW6	9-405339	1	SWITCH, HORN
SW7		1	SWITCH, CARRIAGE TILT
SW8		1	SWITCH, CAB FAN
SW9	9-191455	1	SWITCH, POSITIVE AIR SHUTOFF
SW10	9-191455	1	SWITCH, BOOM LIGHTS
SW11	9-191457	1	SWITCH, WORK LIGHTS
SW12	9-191457	1	SWITCH, TURN SIGNALS
SW13		1	SWITCH, CAB INTERIOR LIGHT
SW14	9-191459	1	SWITCH, WINDSHIELD WASHER WIPER
SW15		1	SWITCH, QUICK COUPLER
SW16		1	
SW17	9-191491	1	SWITCH, BLOWER
SW18	9-191491	1	SWITCH, AIR CONDITIONING
SW19	9-191457	1	SWITCH, ROAD LIGHTS
SW20		1	
SW21		1	
SW22		1	
SW23	9-191455	1	SWITCH, HAZARD LIGHTS
SW24		1	SWITCH, WASHER/WIPER
SW25	9-191457	1	SWITCH, CONTINUOUS FLOW FORWARD/REVERSE
SW26	9-206757	1	SWITCH, LOCK/UNLOCK QUICK COUPLER

To Order go to [Discount-Equipment.com](http://Discount-Equipment.com)

### 3.4 Hydraulic Schematic Parts List

Index No.	Skyjack Part No.	Qty.	Description
C1	9-206943	1	LIFT CYLINDER
C2	9-206945	1	FORK TILT CYLINDER
C3	9-205961	1	TILT COMPENSATION CYLINDER
C4	9-206944	1	EXTENSION CYLINDER
C5		1	FRONT STEER CYLINDER
C6		1	REAR STEER CYLINDER
C9	9-205964	1	QUICK COUPLER CYLINDER
C12		1	PARK BRAKE CYLINDER
CB1	9-224026	1	COUNTERBALANCE VALVE 5000 PSI
CB2	9-224027	1	COUNTERBALANCE VALVE 3000 PSI
CB3	9-224014	1	COUNTERBALANCE VALVE 5000 PSI
CB4	9-224026	1	COUNTERBALANCE VALVE 5000 PSI
CB5	9-224027	1	COUNTERBALANCE VALVE 3000 PSI
EC1		1	PRESSURE COMPENSATOR
F1	9-206998	1	RETURN FILTER
F2	9-191484	1	TANK FILLER FILTER
F3	9-206887	1	CHARGE FILTER
JS1	9-190356	1	JOYSTICK
M1	9-206918	1	DRIVE MOTOR
MB1	9-206311	1	MAIN MANIFOLD
MB2	9-206310	1	PILOT MANIFOLD
OR1		1	ORIFICE 0.062"
OR2		1	ORIFICE 0.035"
OR3		1	ORIFICE 0.047"
ORB1	9-205277	1	ORBITAL STEERING MOTOR
P1	9-205852	1	DRIVE PUMP
P1A	9-205852	1	CHARGE PUMP
P2	9-206718	1	SYSTEM PUMP
PC1		1	PILOT OPERATED CHECK VALVE
PC2		1	PILOT OPERATED CHECK VALVE
PRV1		1	PRESSURE REDUCING VALVE 320 psi
PS1	9-205893	1	BRAKE SWITCH AND ROAD LIGHT OPTION
PT1		1	PRESSURE TRANSDUCER
PT2		1	PRESSURE TRANSDUCER
RV1	9-224050	1	RELIEF VALVE 3900 psi
RV2	9-224048	1	RELIEF VALVE 3000 psi
RV3	9-224048	1	RELIEF VALVE 3000 psi
RV4	9-224049	1	RELIEF VALVE 3500 psi
RV5	9-224049	1	RELIEF VALVE 3500 psi
RV6		1	RELIEF VALVE 348 psi
RV7		1	RELIEF VALVE 6500 psi
RV8		1	RELIEF VALVE 6500 psi
RV9		1	RELIEF VALVE 7000 psi
RV10		1	RELIEF VALVE 7000 psi
RV11		1	RELIEF VALVE 600 psi
RV12		1	RELIEF VALVE 600 psi
RV14		1	RELIEF VALVE 2000 psi

Index No.	Skyjack Part No.	Qty.	Description
RV15		1	RELIEF VALVE 2900 psi
RV16		1	RELIEF VALVE 2900 psi
V12		1	SERVICE BRAKE ACTUATOR
V5		1	VALVE SOLENOID
3H-26	9-224051	1	VALVE, SOLENOID - PARK BRAKE
3H-233	9-224051	1	VALVE, SOLENOID - CONT AUX FWD
3H-234	9-224051	1	VALVE, SOLENOID - CONT AUX REV
4H-47	9-224052	1	VALVE, SOLENOID - CARRIAGE UP
4H-47-1	9-224052	1	VALVE, SOLENOID - CARRIAGE DOWN
4H-237A	9-224052	1	VALVE, SOLENOID - AUX LEFT
4H-237A-1	9-224052	1	VALVE, SOLENOID - AUX RIGHT

To order go to [Discount-Equipment.com](http://Discount-Equipment.com)



### 3.5 Hydraulic Pump and Return Filter Ports Identification

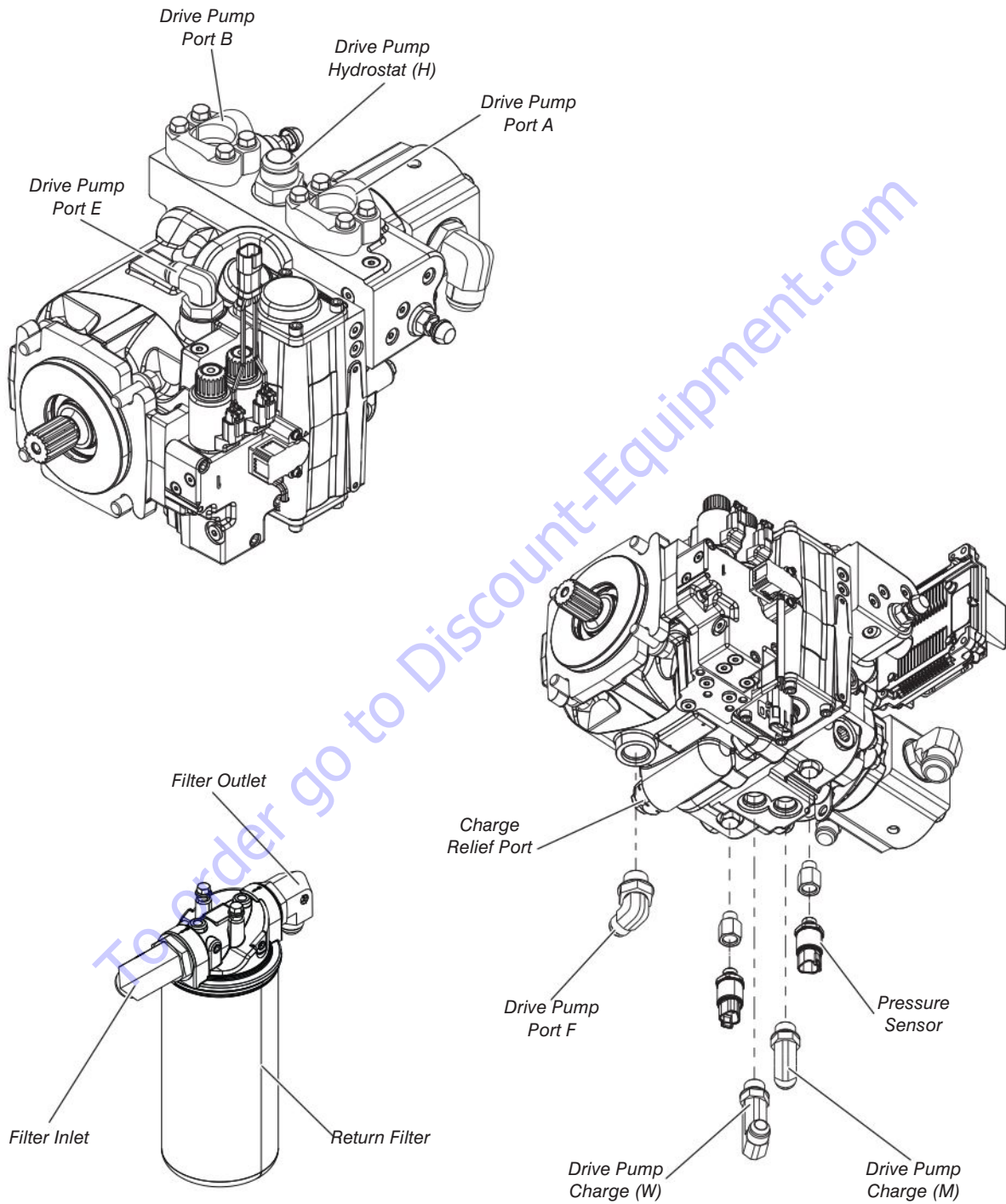

### 3.6 Steer Manifold

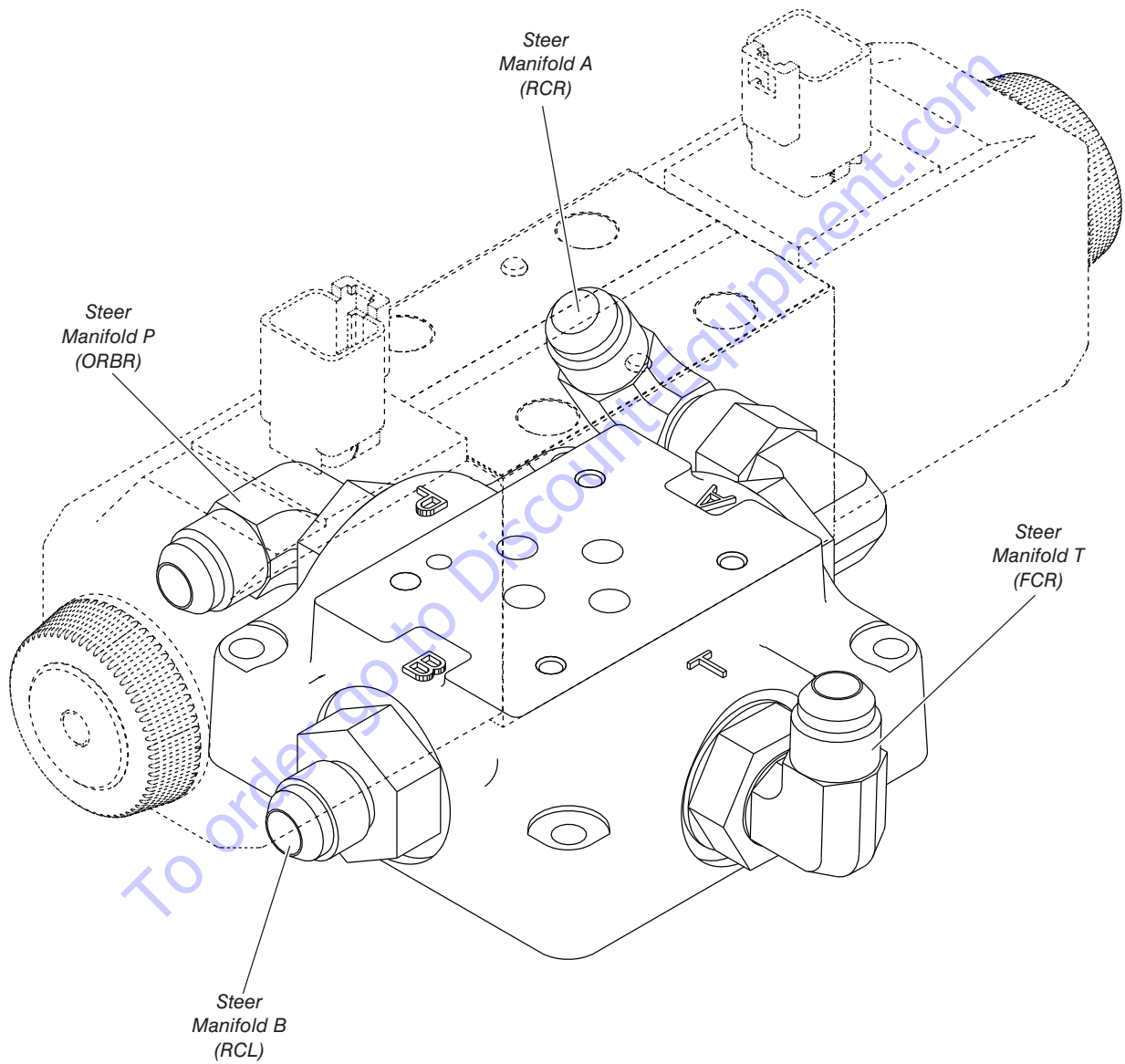

### 3.7 Main Manifold

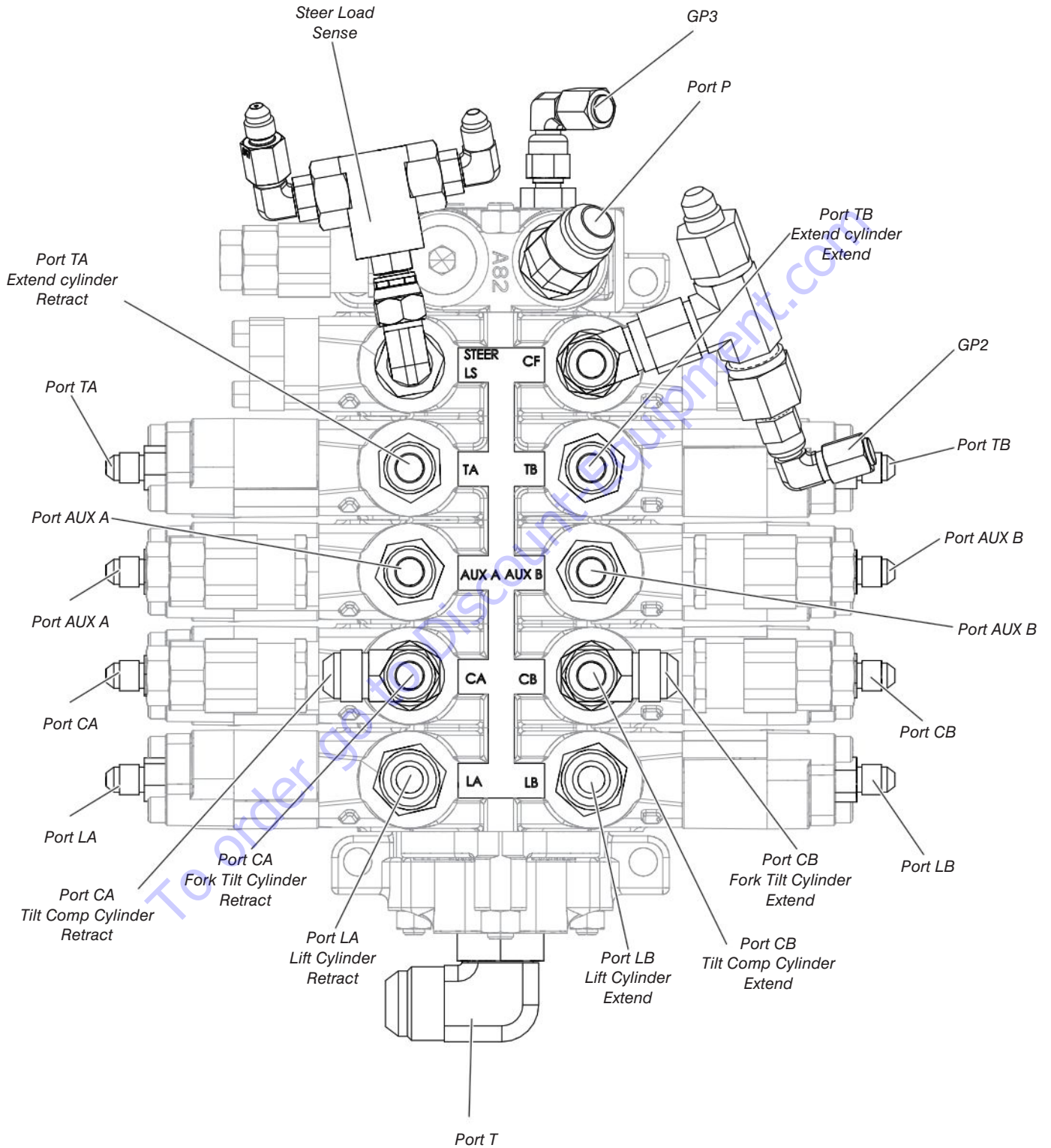

### 3.8 Pilot Manifold

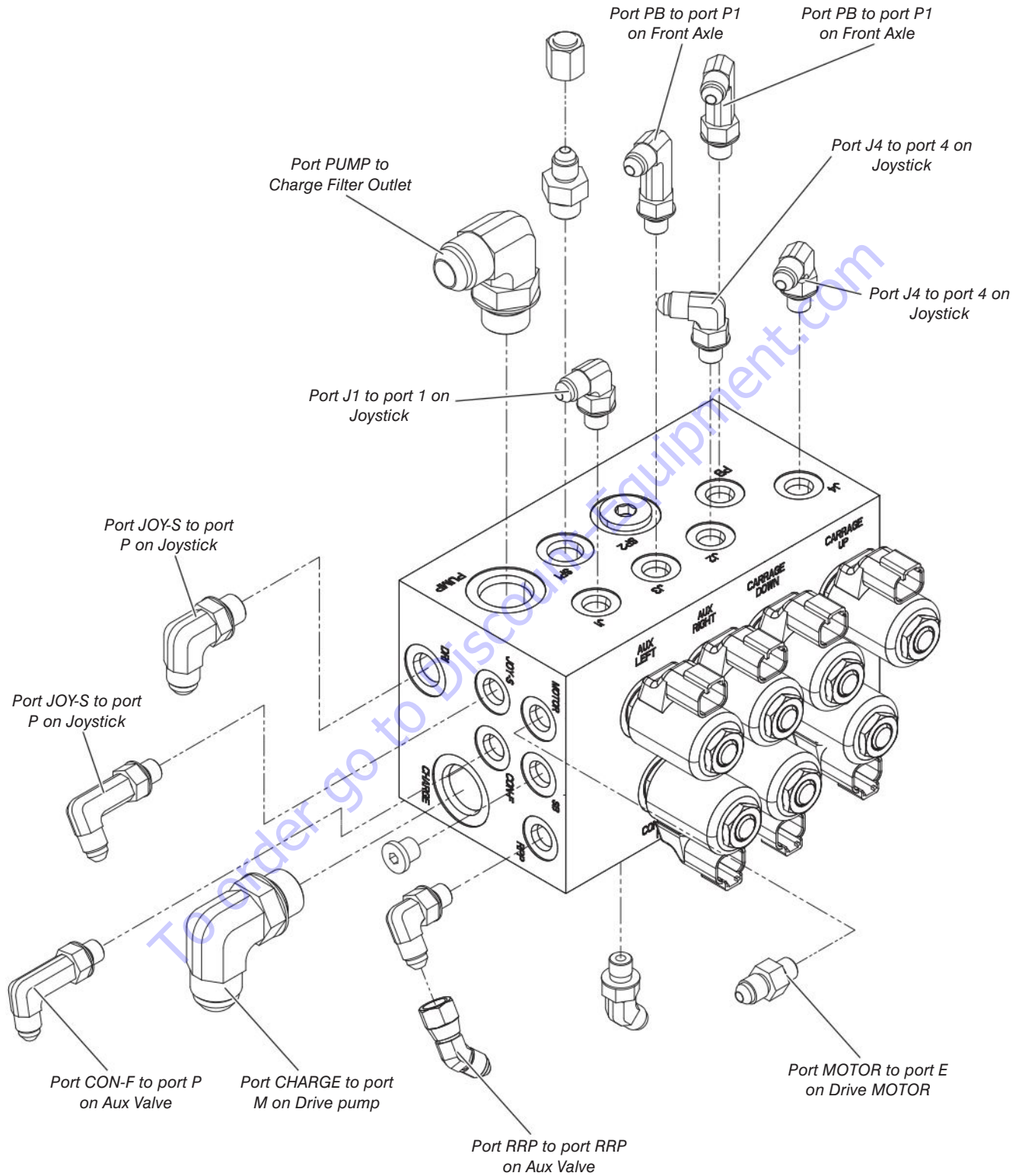

### 3.8 Pilot Manifold

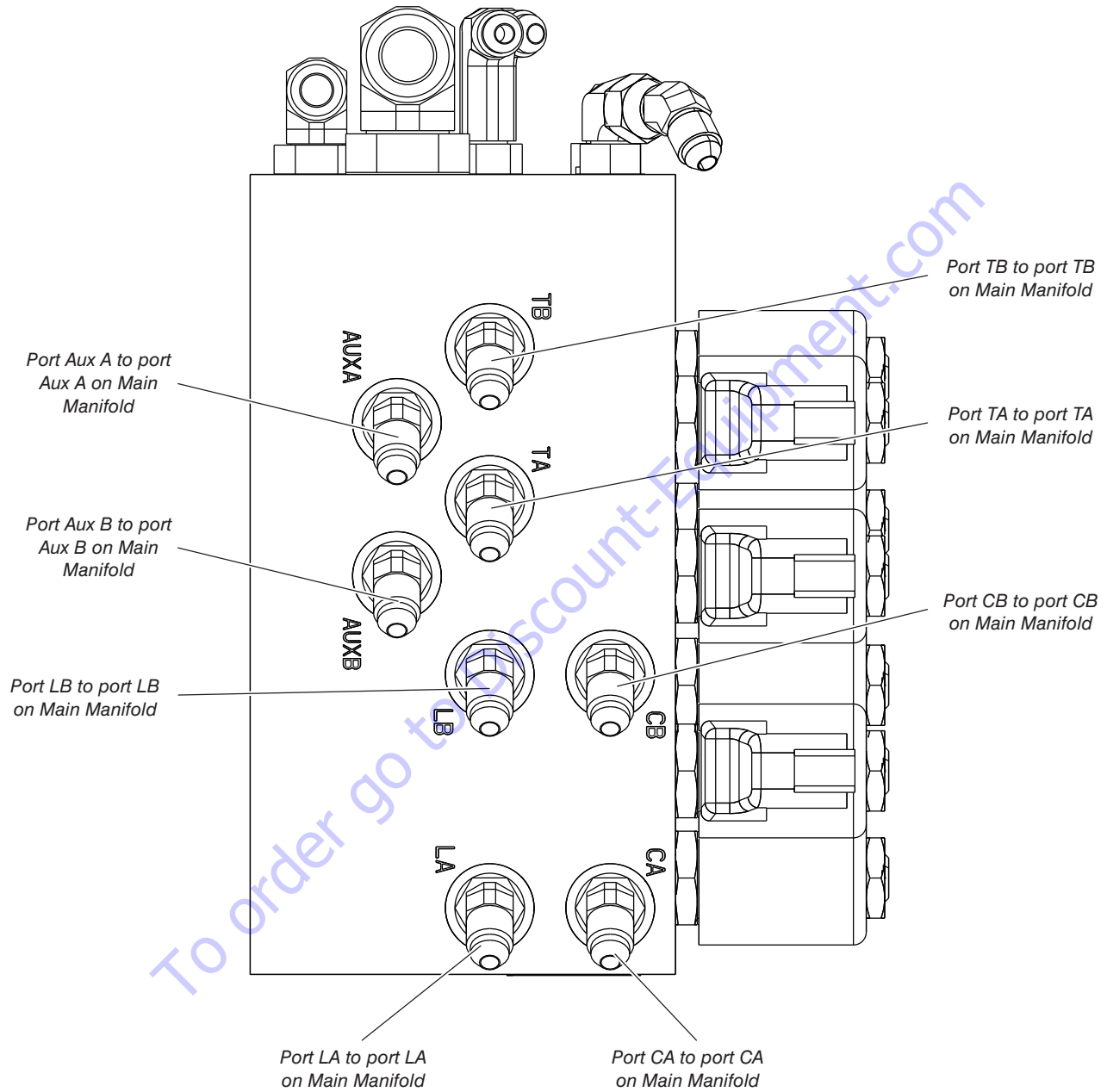

### 3.9 Pedal Ports Identification

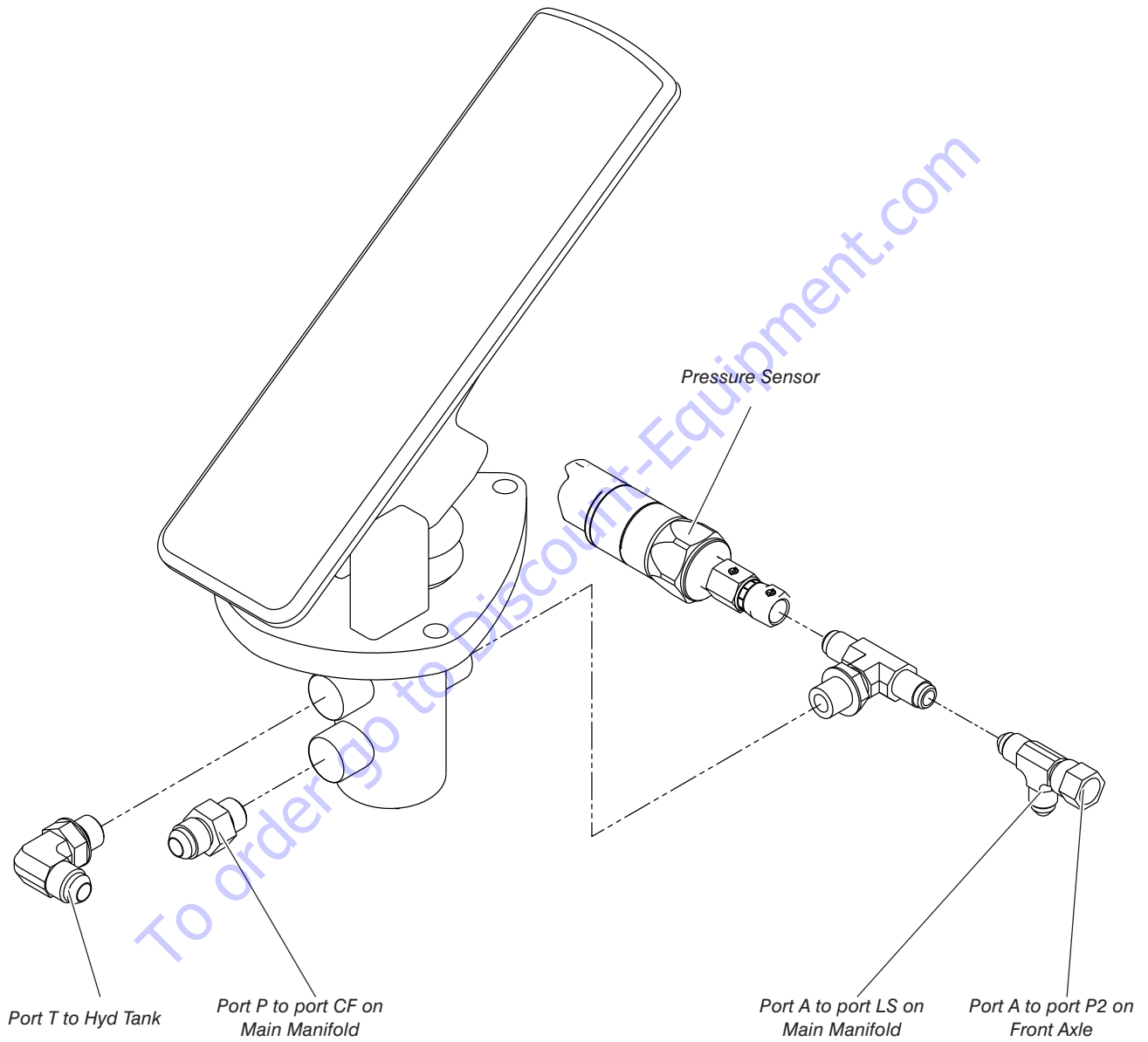

### 3.10 Joystick Ports Identification

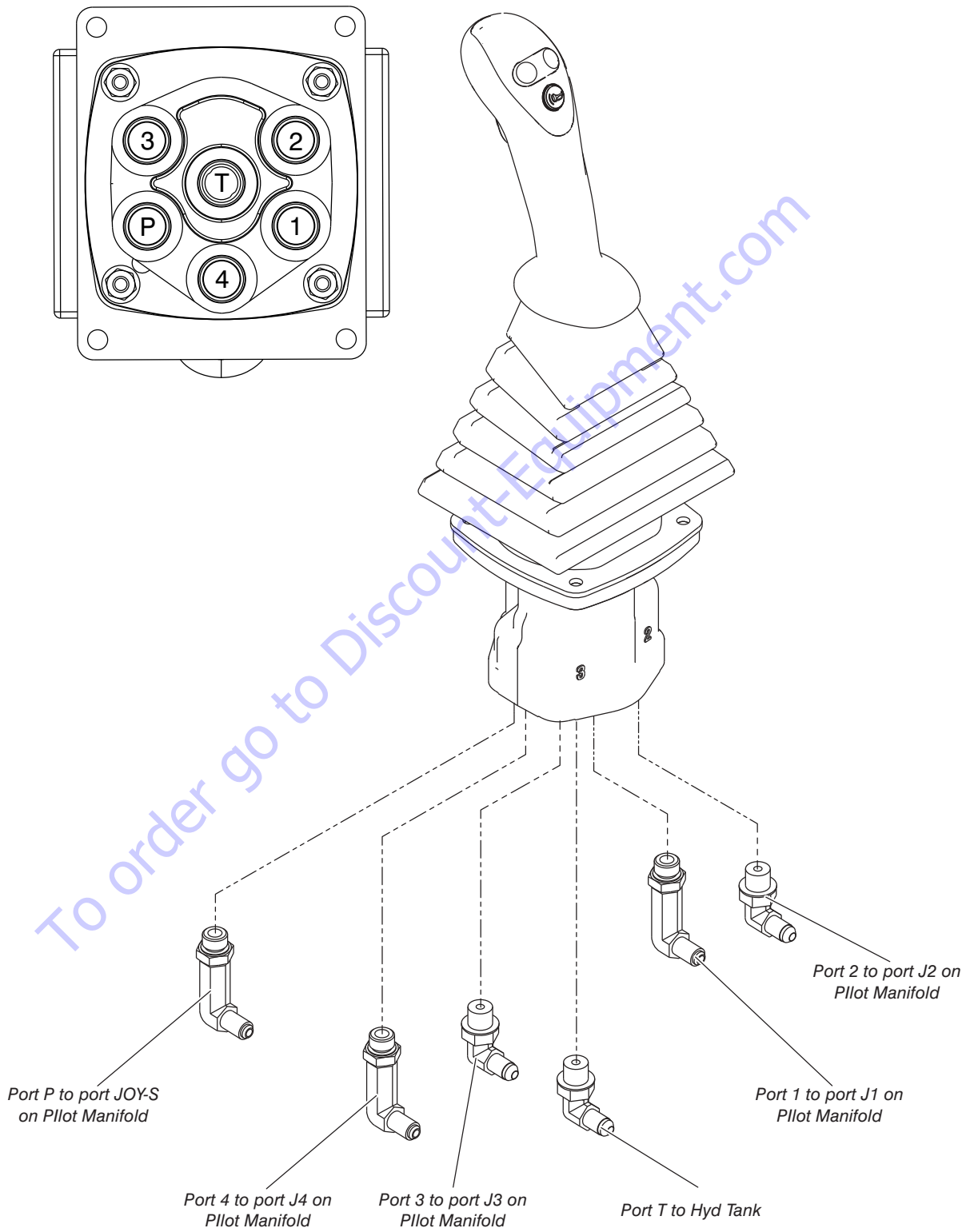

### 3.11 Major Components Identification and Location

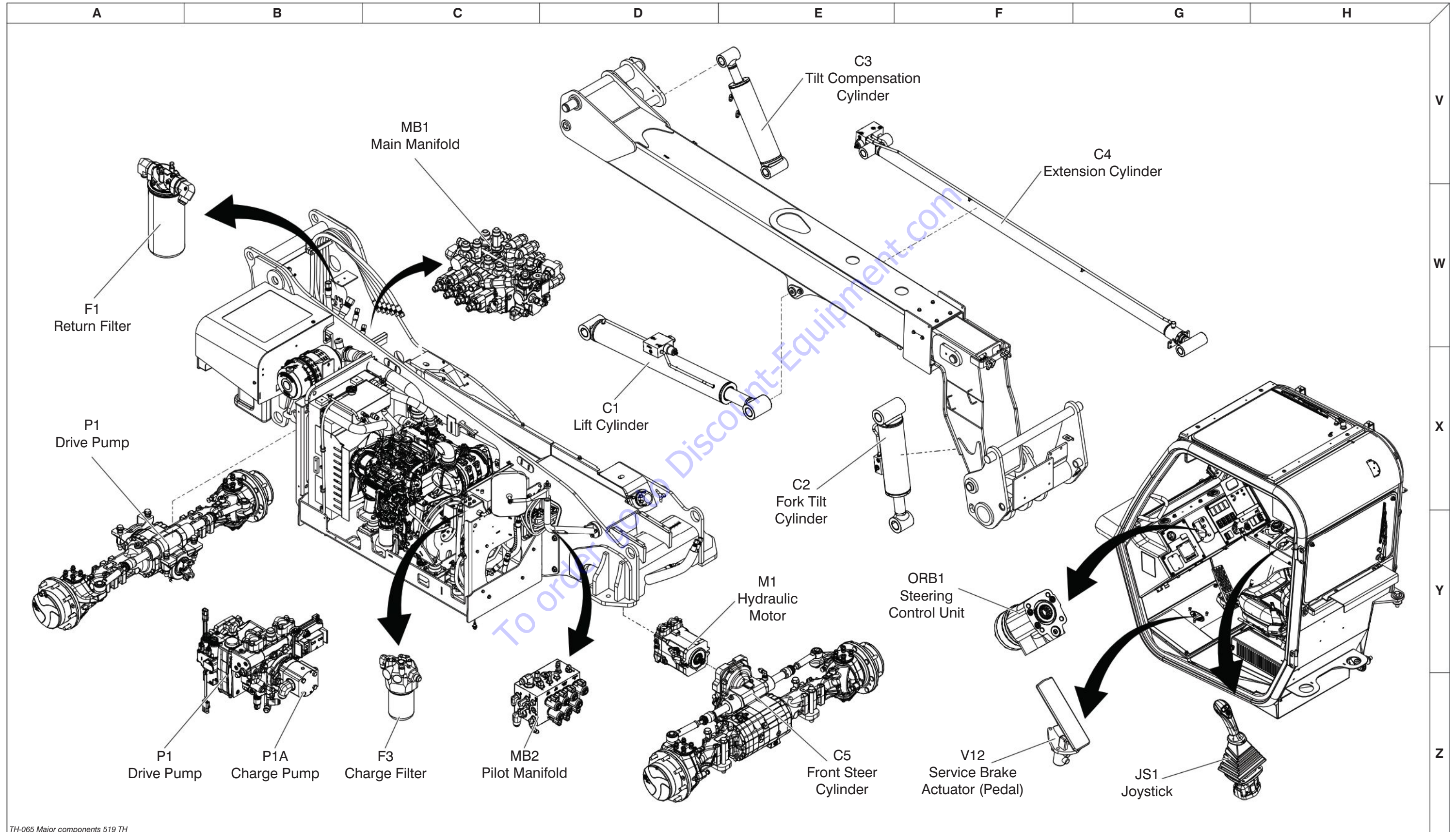

TH-065 Major components 519 TH



### 3.12 Glow Plug Harness

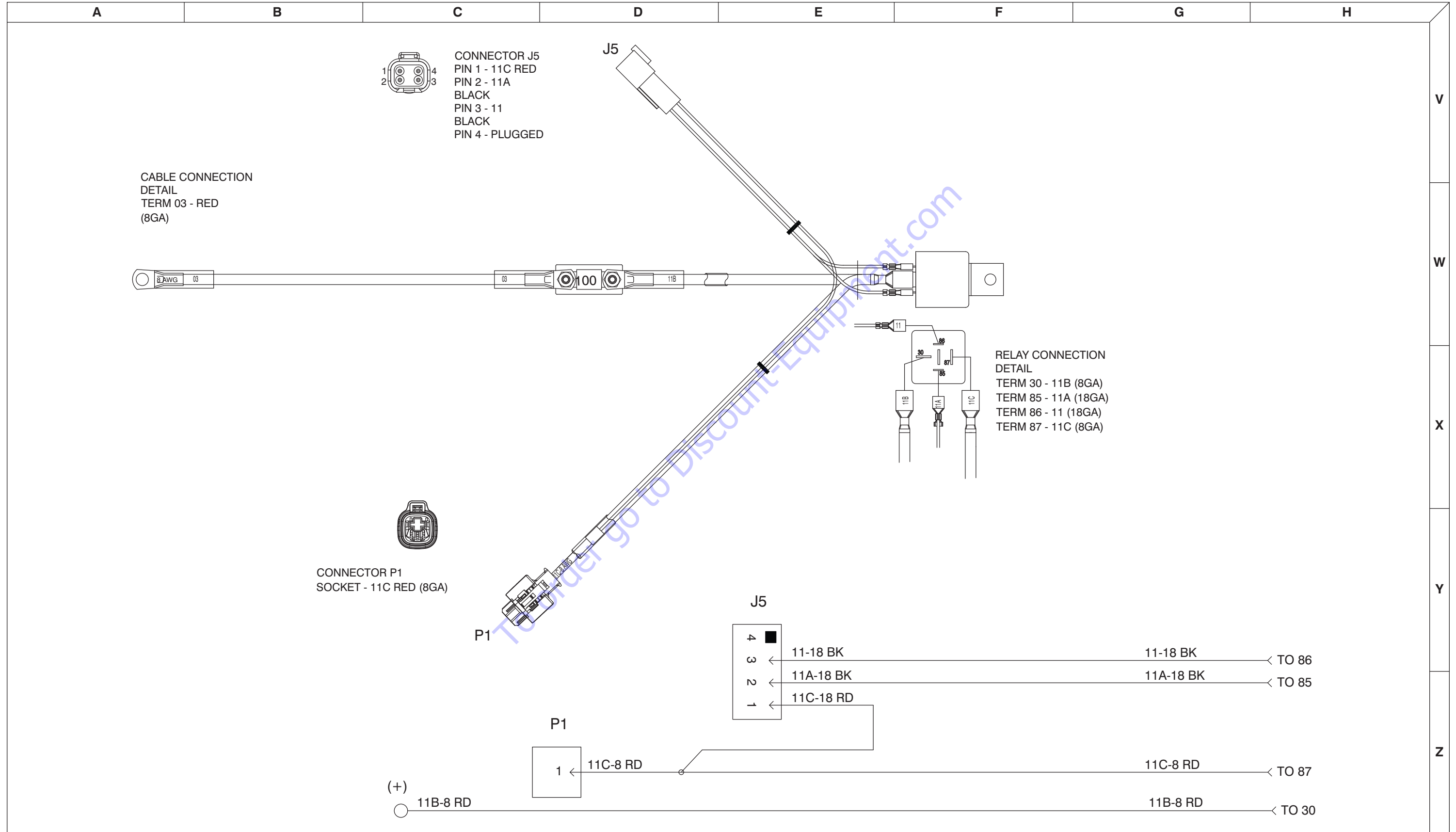

### 3.13 Road Lights Harness

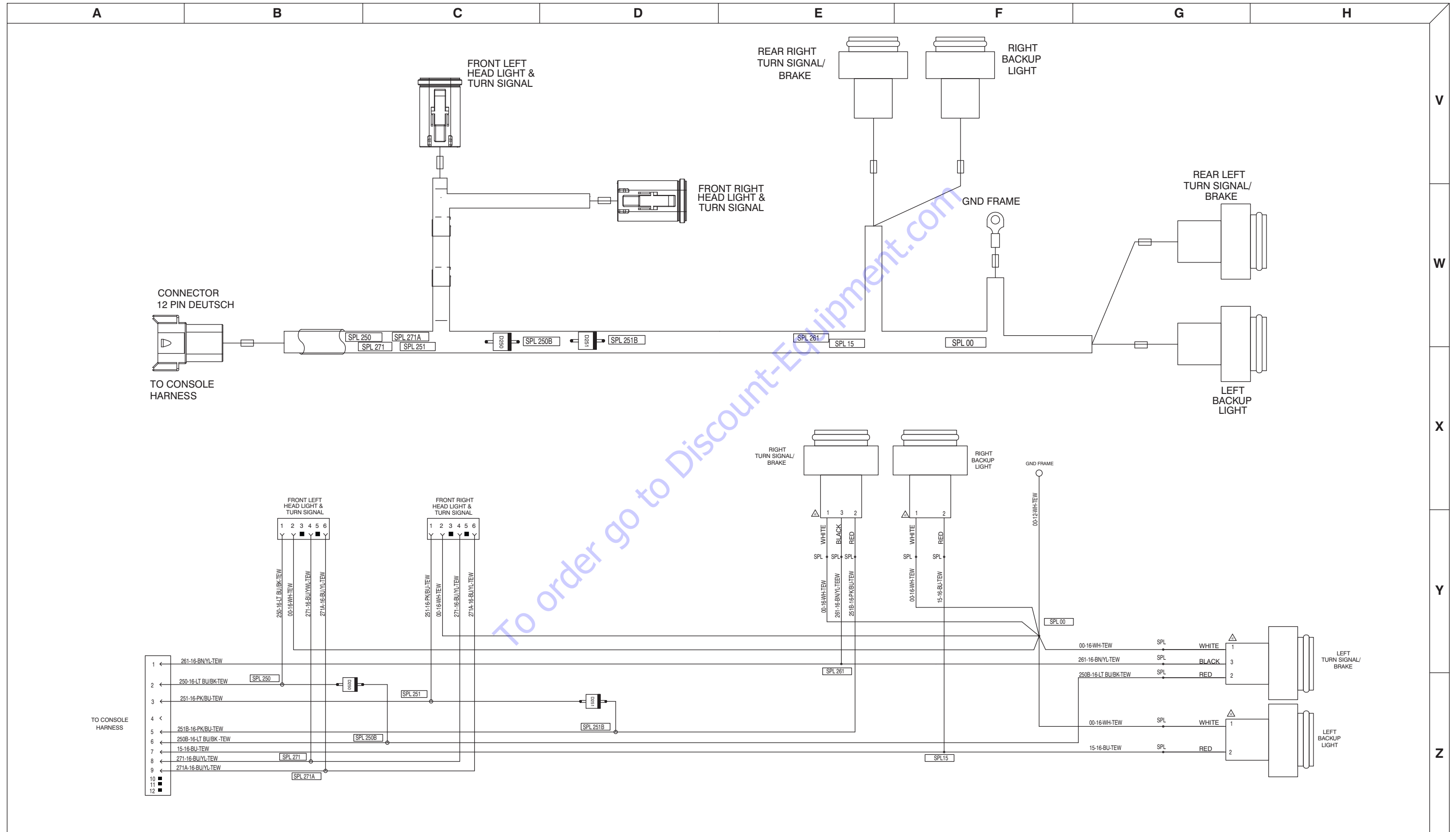

### 3.14 Boom Lights Harness

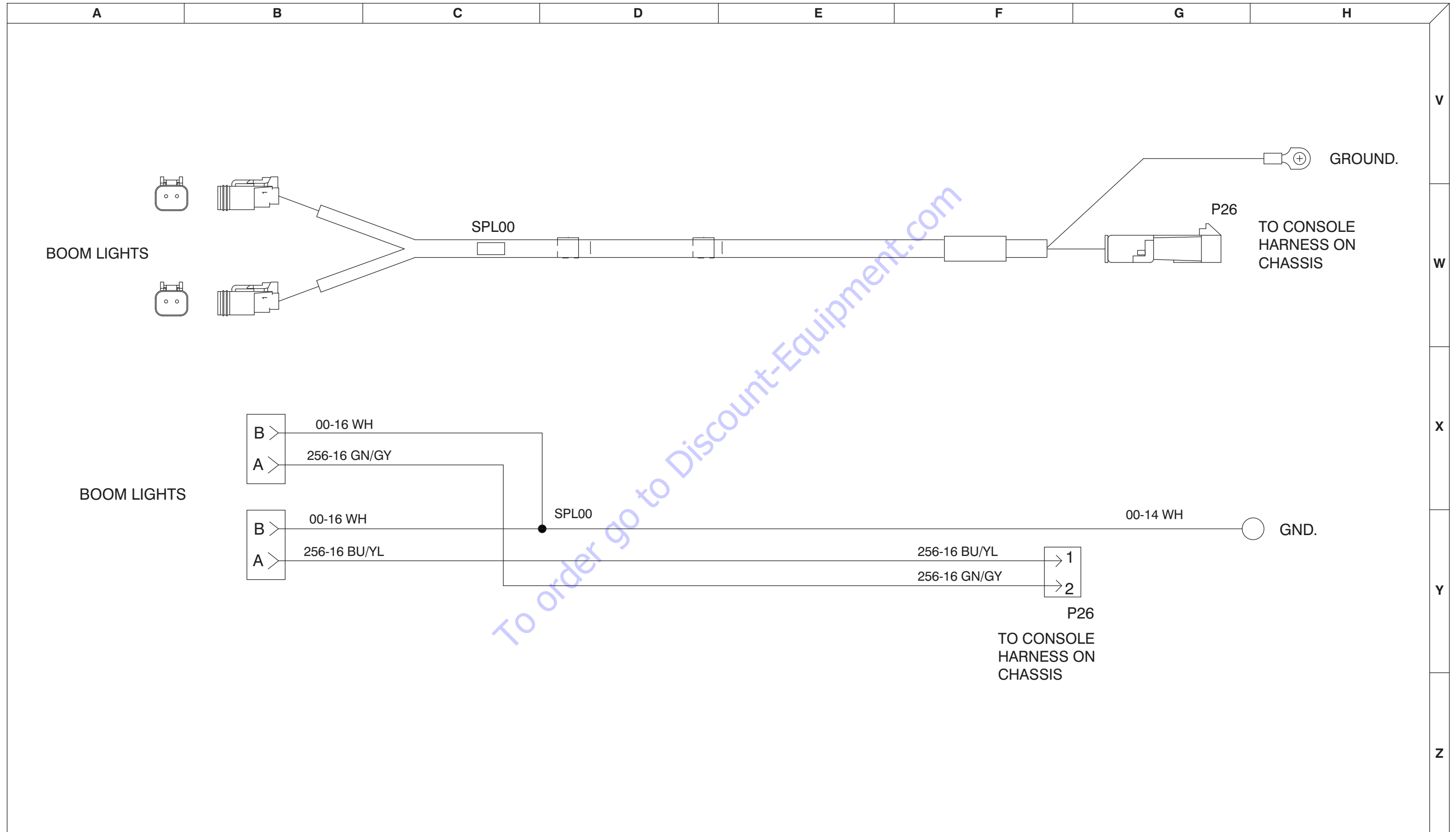

### 3.15 Beacon Light Harness

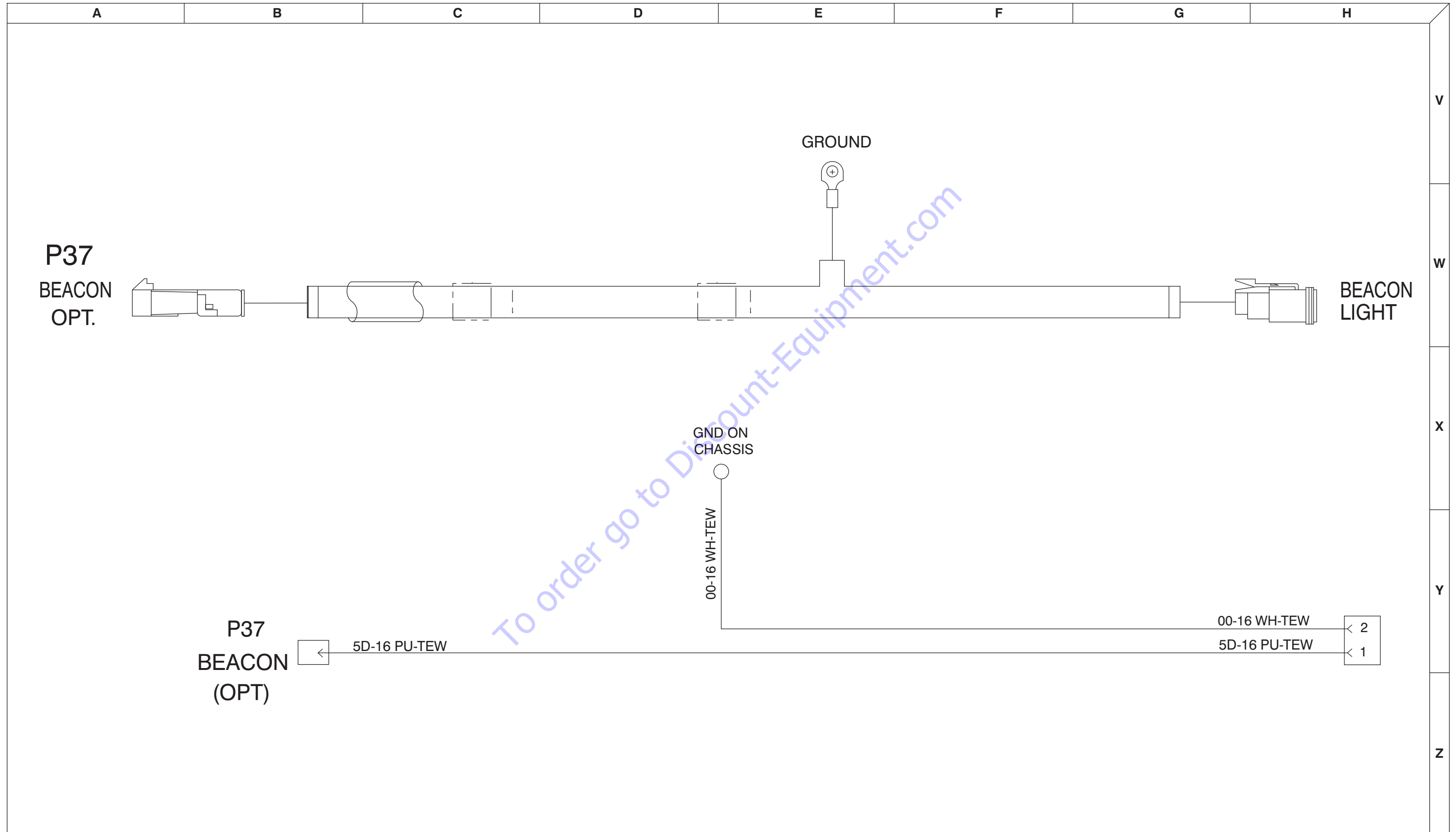

### 3.16 Work Lights Harness

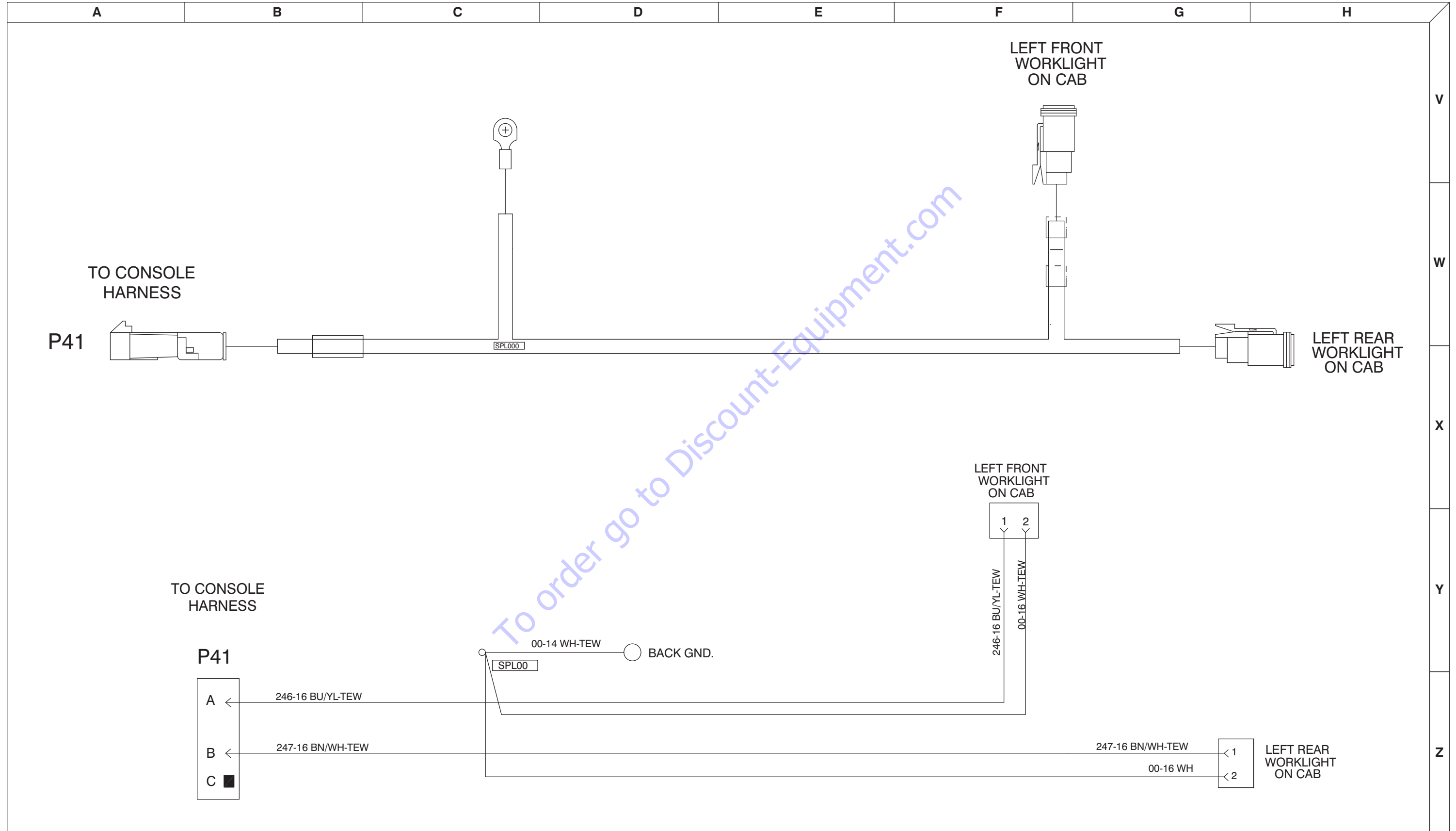

3.17 Console Harness

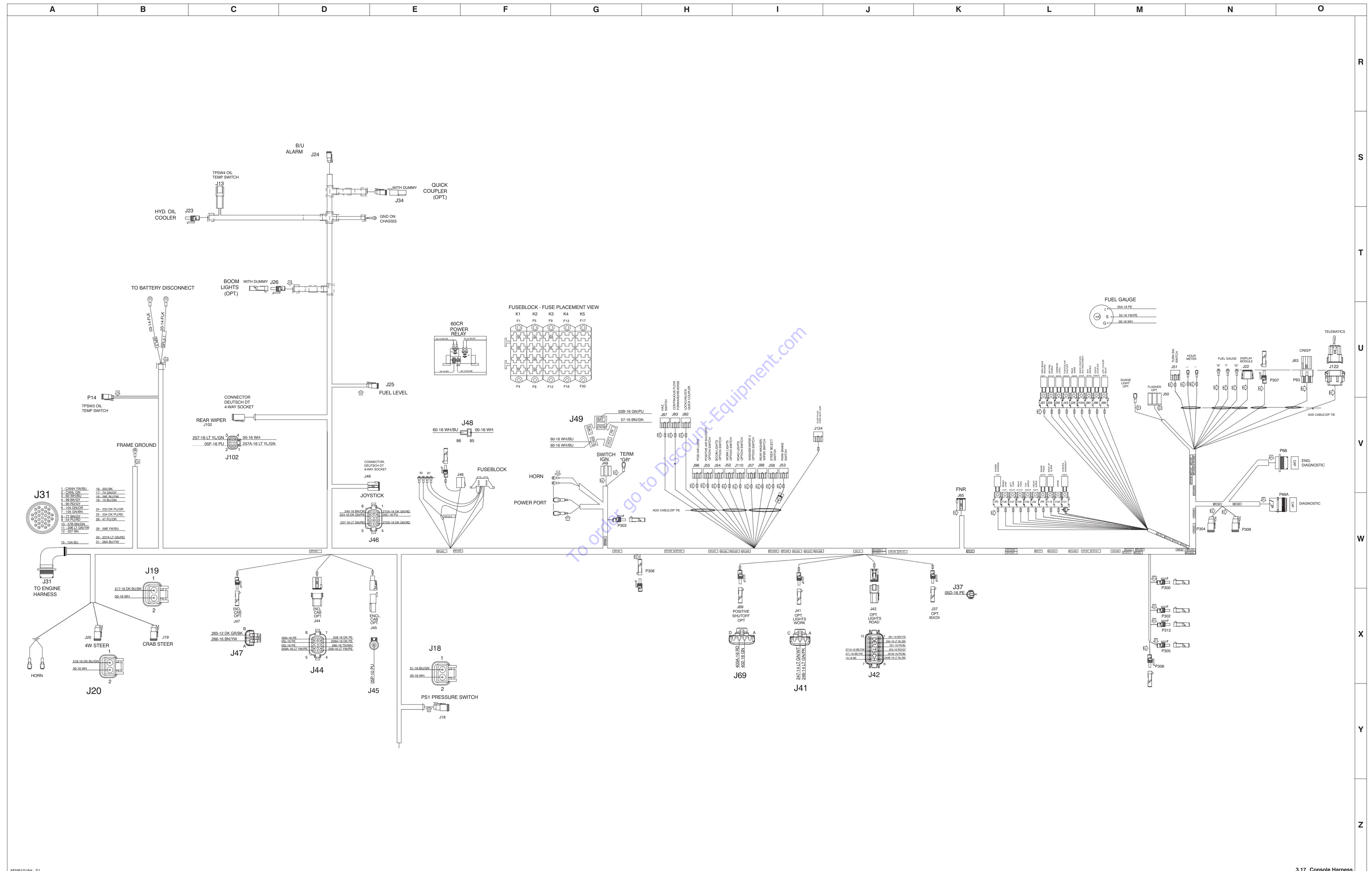

M206101AH - S1

3.17 Console Harness

3.18 Console Harness Wiring

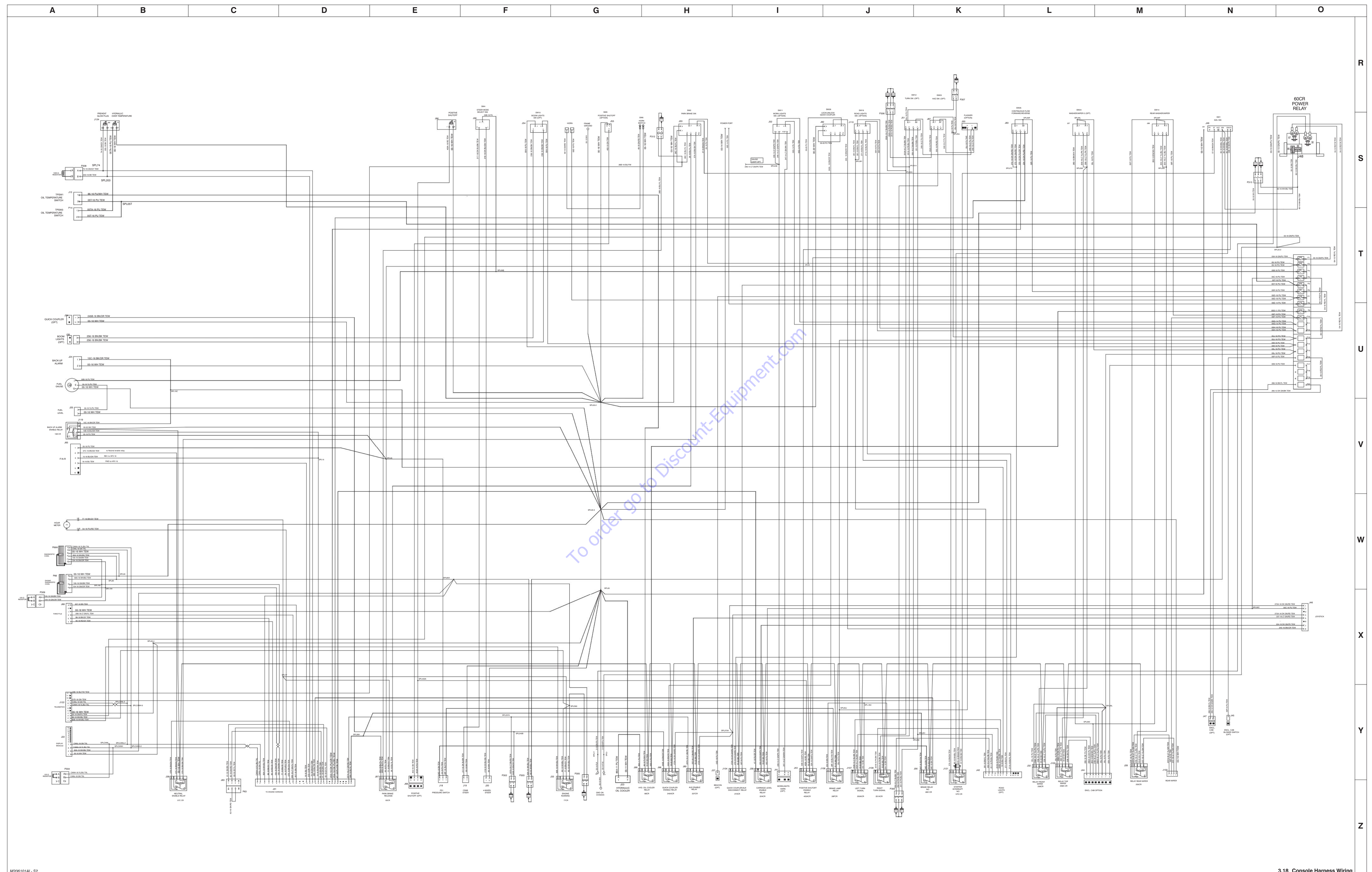

M206101A1 - S2

3.18 Console Harness Wiring

3.19 Engine Harness

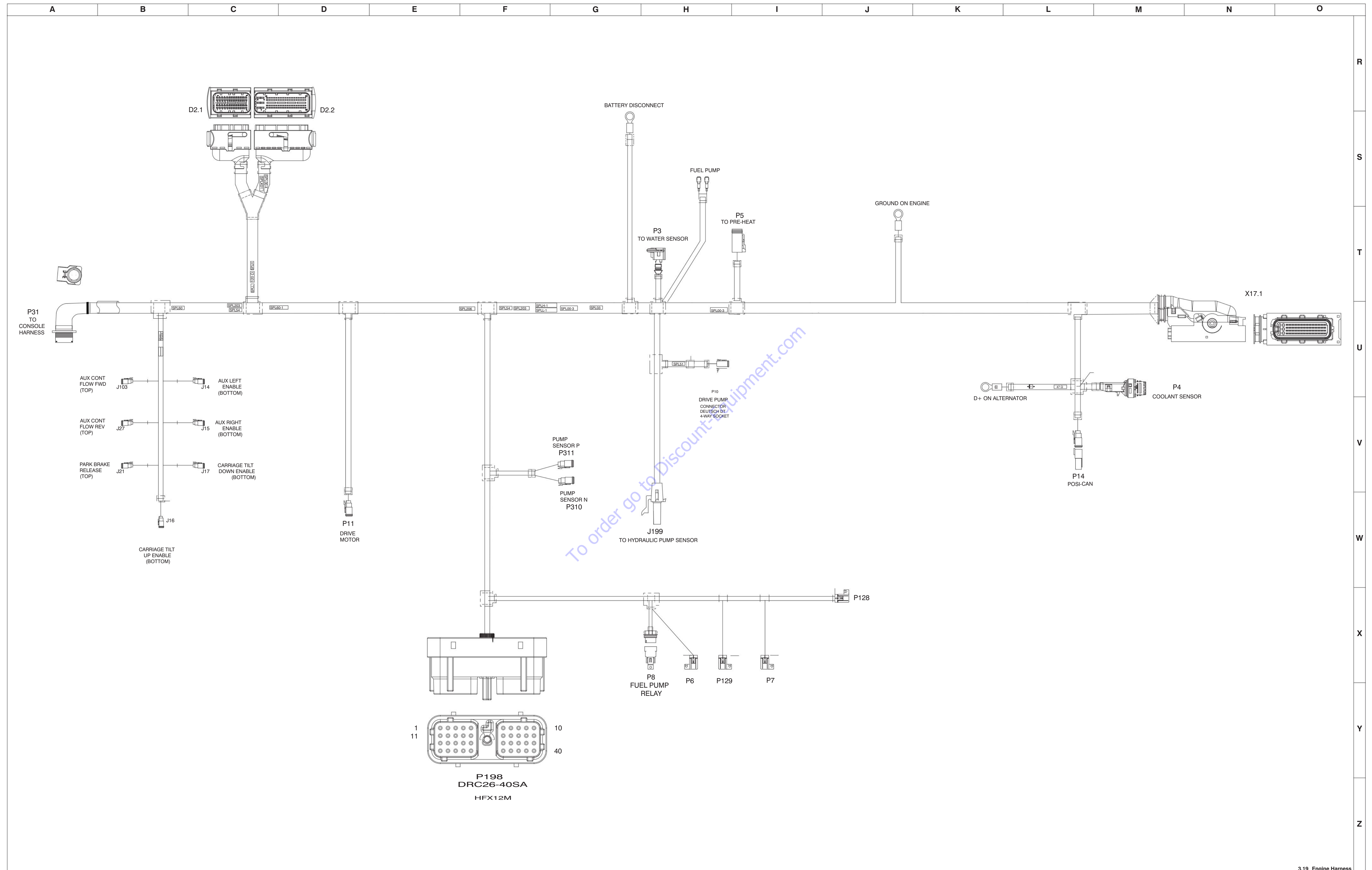



3.20 Engine Harness Wiring

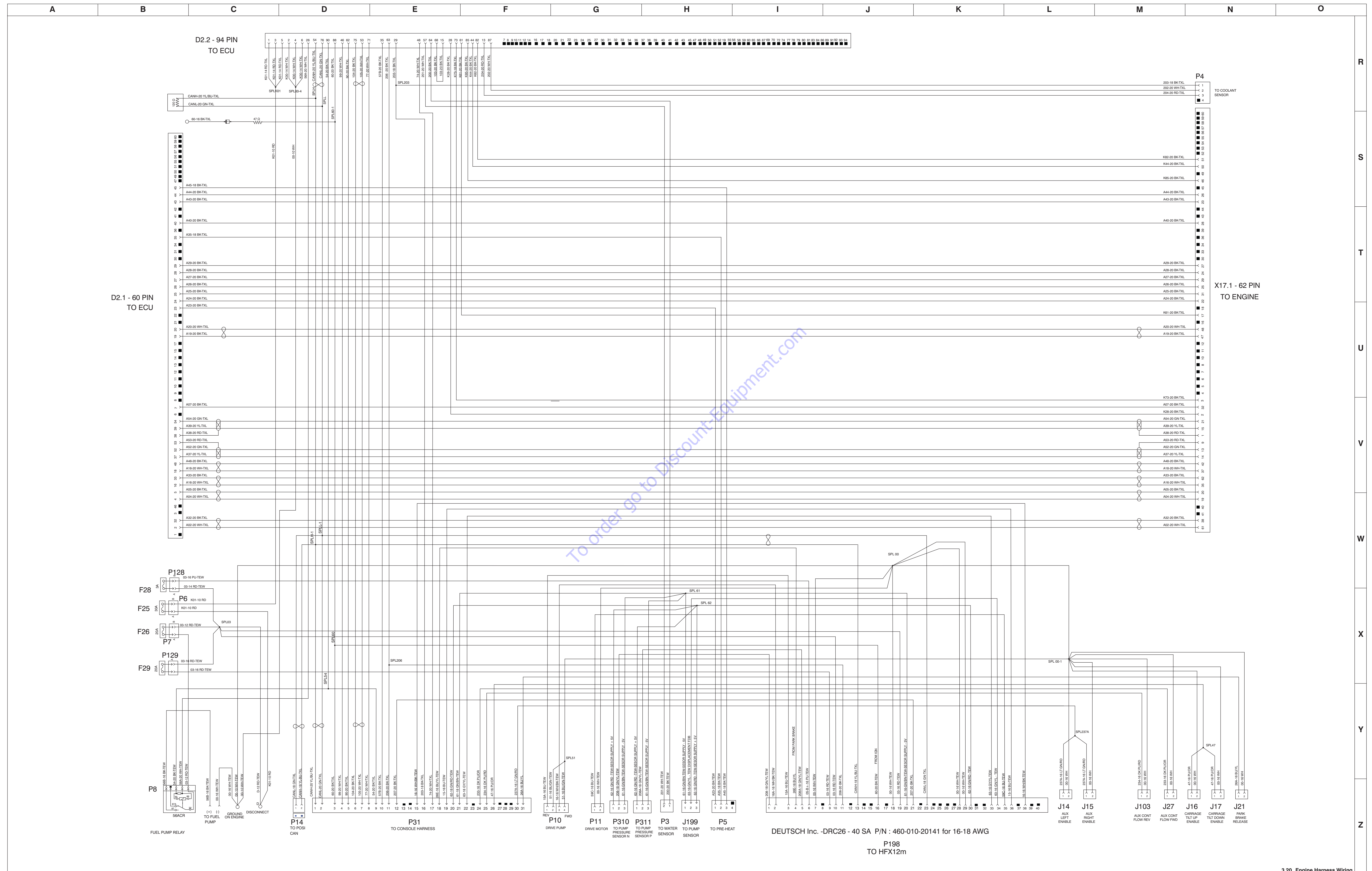

To order go to Discount-Equipment.com

DEUTSCH Inc. -DRC26- 40 SA P/N : 460-010-20141 for 16-18 AWG

P198  
TO HFX12m

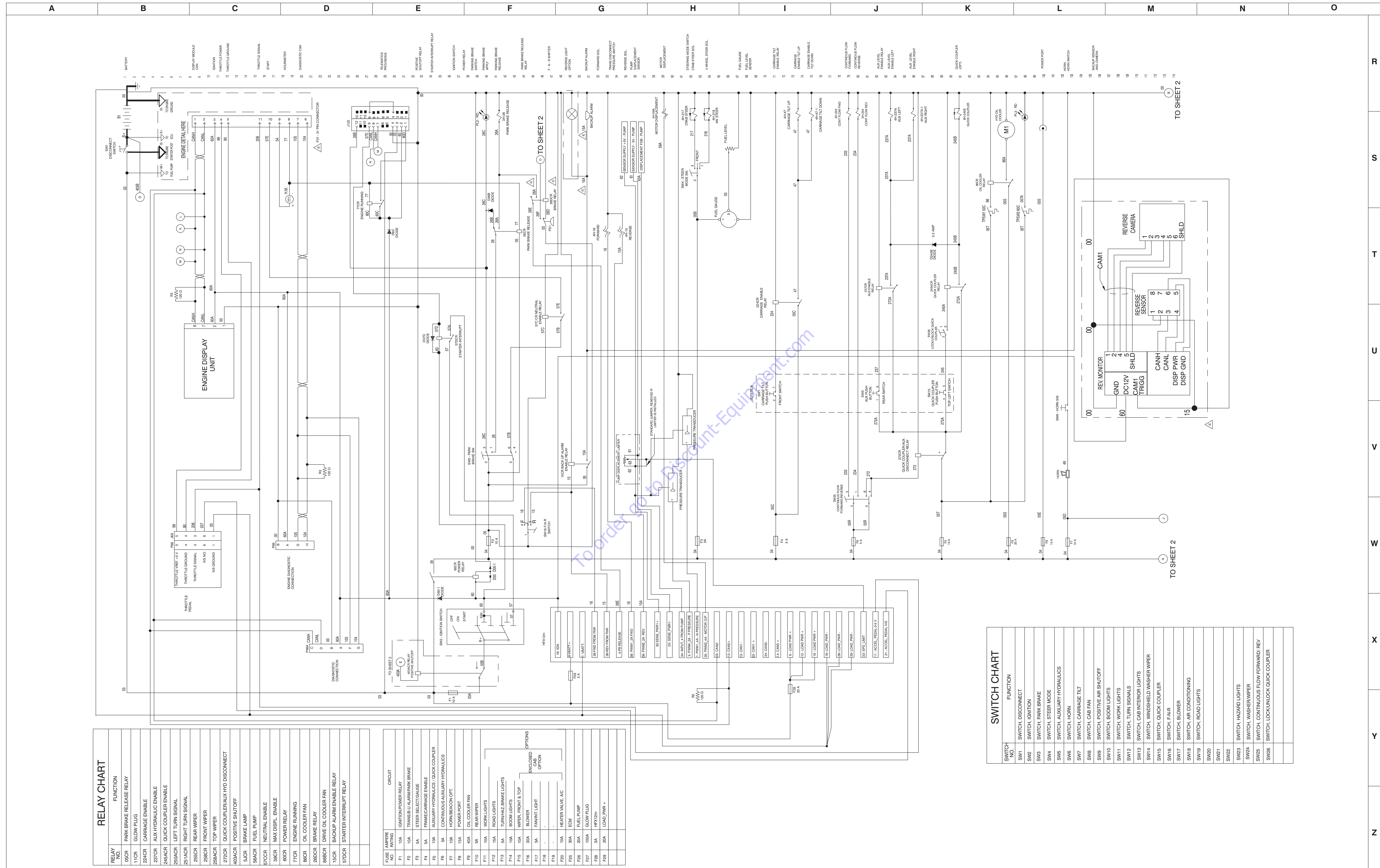

RELAY NO.	FUNCTION
05CR	PARK BRAKE RELEASE RELAY
11CR	GLOW PLUG
22CR	CARRIAGE ENABLE
23CR	AUX HYDRAULIC ENABLE
24SACR	QUICK COUPLER ENABLE
25ACR	LEFT TURN SIGNAL
25JACR	RIGHT TURN SIGNAL
25SCR	REAR WIPER
25CACR	FRONT WIPER
25SACR	TOP WIPER
27ZCR	QUICK COUPLER/AUX HYD DISCONNECT
40ACR	POSITIVE SHUTOFF
51CR	BRAKE LAMP
56ACR	FUEL PUMP
57CCR	NEUTRAL ENABLE
58CR	MAX DISPL. ENABLE
60CR	POWER RELAY
77CR	ENGINE RUNNING
86CR	OIL COOLER FAN
88CR	BRAKE RELAY
88CCR	DRIVE OIL COOLER FAN
15CR	BACKUP ALARM ENABLE RELAY
57CCR	STARTER INTERRUPT RELAY

FUSE AMPERE NO.	AMPERE RATING	CIRCUIT
F1	10A	IGNITION/POWER RELAY
F2	10A	TRANS/SLU ALARM/PARK BRAKE
F3	5A	STEER SELECT/GAUGE
F4	5A	FRAME CHARGE ENABLE
F5	10A	AUXILIARY HYDRAULICS / QUICK COUPLER
F6	5A	CONTINUOUS AUXILIARY HYDRAULICS
F7	10A	HORN/BLAZON/OPT
F8	15A	POWER PORT
F9	40A	OIL COOLER FAN
F10	5A	REAR WIPER
F11	10A	WORK LIGHTS
F12	10A	ROAD LIGHTS
F13	5A	TURN/HAZ BRAKE LIGHTS
F14	10A	ROOM LIGHTS
F15	10A	WIPER FRONT & TOP
F16	30A	BLOWER
F17	5A	PAINT LIGHT
F18	-	ENCLOSED OPTION
F19	-	ENCLOSED OPTION
F20	10A	HEATER VALVE JAC
F21	5A	ECM
F22	30A	FUEL PUMP
F23	100A	GLOW PLUG
F24	3A	HEX120
F25	20A	LOAD PWR +

SWITCH NO.	FUNCTION
SW1	SWITCH DISCONNECT
SW2	SWITCH IGNITION
SW3	SWITCH PARK BRAKE
SW4	SWITCH STEER MODE
SW5	SWITCH AUXILIARY HYDRAULICS
SW6	SWITCH HORN
SW7	SWITCH CARRIAGE TILT
SW8	SWITCH CAB FAN
SW9	SWITCH POSITIVE AIR SHUTOFF
SW10	SWITCH BOOM LIGHTS
SW11	SWITCH WORK LIGHTS
SW12	SWITCH TURN SIGNALS
SW13	SWITCH CAB INTERIOR LIGHTS
SW14	SWITCH WINDSHIELD WASHER WIPER
SW15	SWITCH QUICK COUPLER
SW16	SWITCH F-NR
SW17	SWITCH BLOWER
SW18	SWITCH AIR CONDITIONING
SW19	SWITCH ROAD LIGHTS
SW20	
SW21	
SW22	
SW23	SWITCH HAZARD LIGHTS
SW24	SWITCH WASHER WIPER
SW25	SWITCH CONTINUOUS FLOW FORWARD/REV
SW26	SWITCH LOCK/UNLOCK QUICK COUPLER

RELAY CHART

SWITCH CHART

3.21 Electrical Schematic

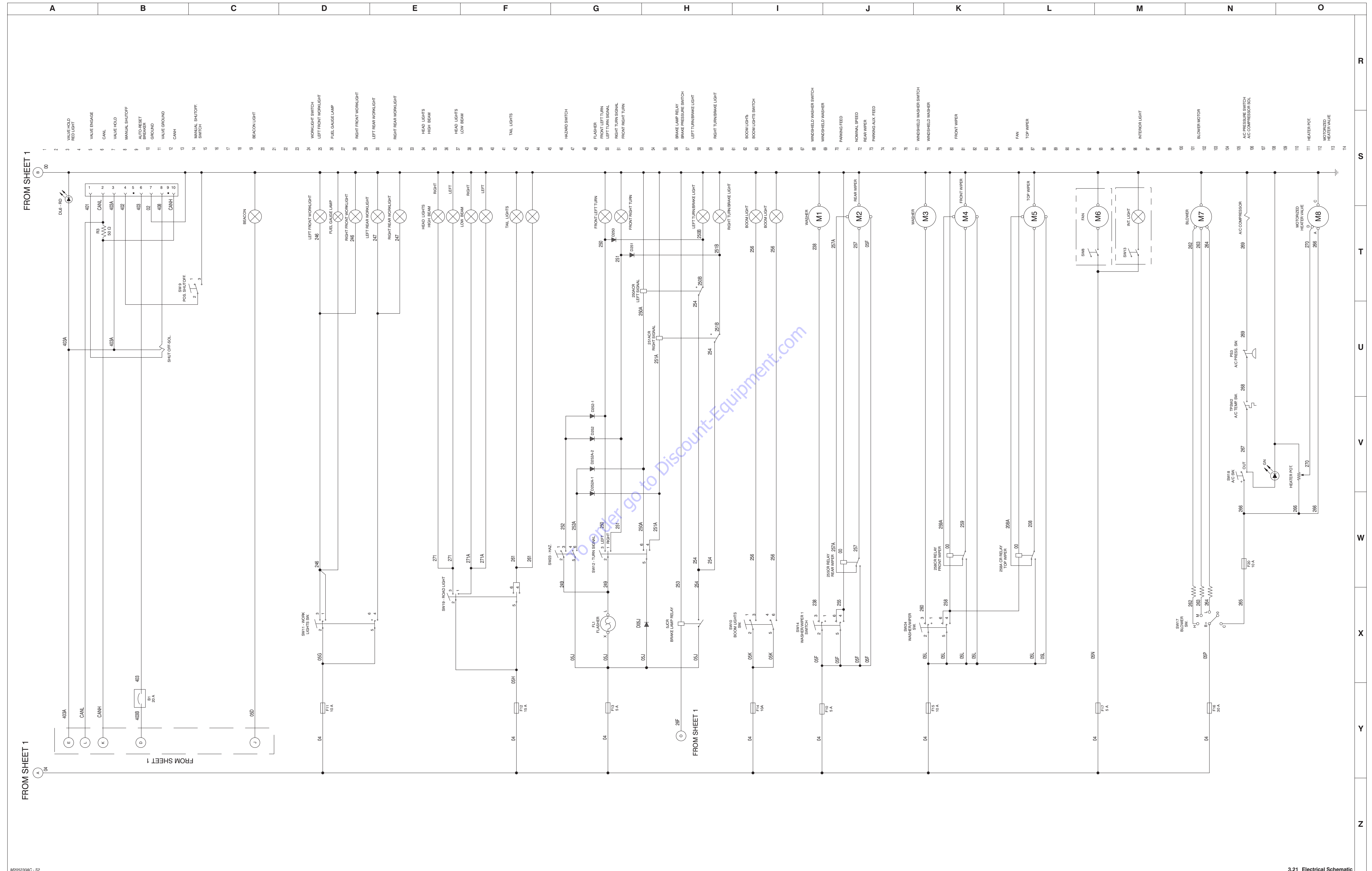

M205230AC - S2

3.21 Electrical Schematic



3.22 Hydraulic Schematic

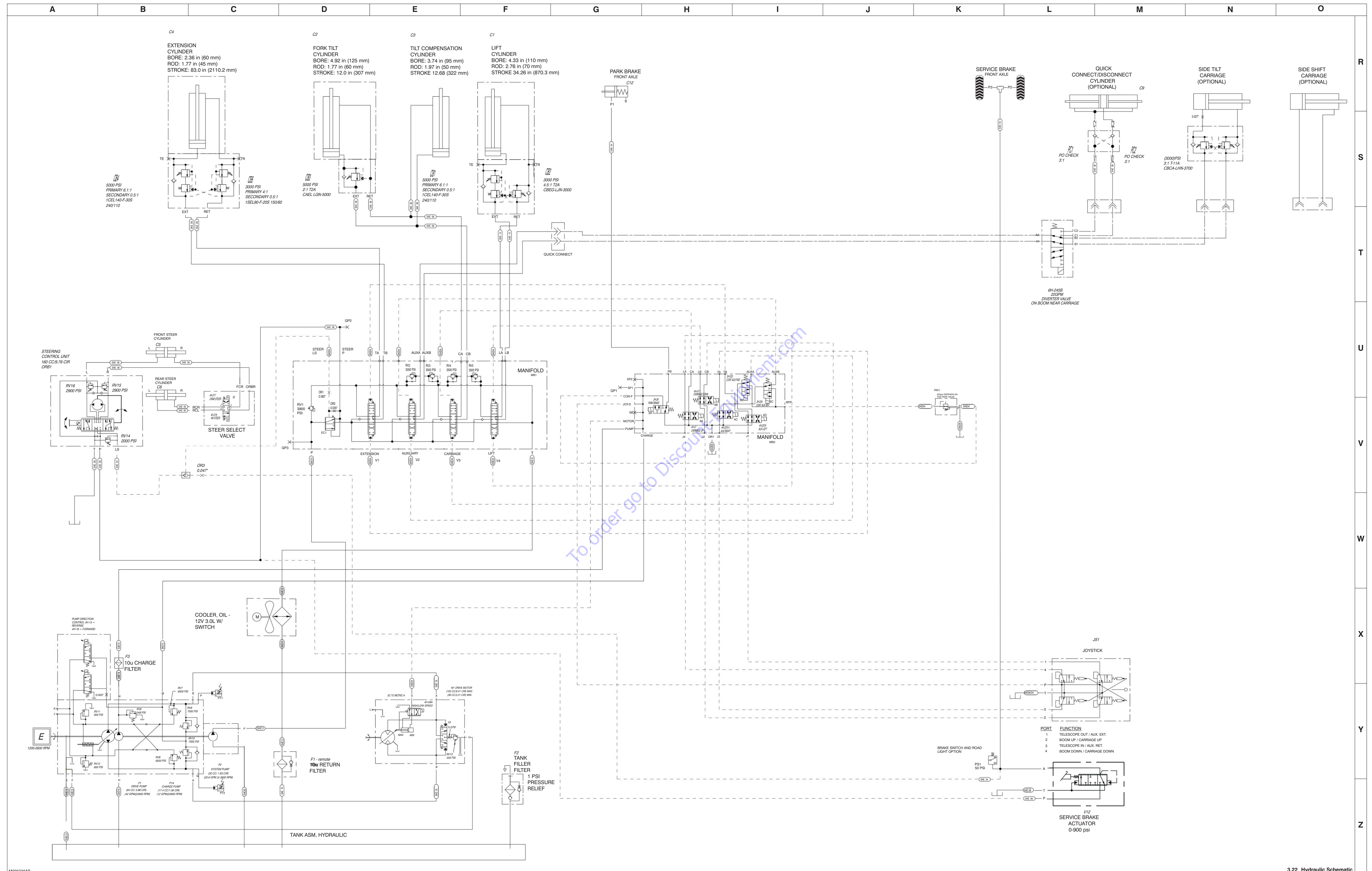

M205220AB

3.22 Hydraulic Schematic

---

# Section 4 – Troubleshooting Information

## 4.1 Introduction

The following pages contain a table of Troubleshooting for locating and correcting most service trouble which can develop. Careful and accurate analysis of the systems listed in the table of Troubleshooting will localize the trouble more quickly than any other method. This manual cannot cover all possible troubles and deficiencies that may occur. If a specific trouble is not listed, isolate the major component in which the trouble occurs, isolate whether the problem is electrical or hydraulic, and then isolate and correct the specific problem.

The content of this section is separated into “probable cause” and “remedy.” The information in the left-hand column, preceded by a number, represents the “probable cause.” The information in the right-hand column, in bold text, represents the “remedy” to the “probable cause” directly beside it. See the example below for clarification.

---

1. Probable cause

**Remedy**

---

## 4.2 Electrical System

### 4.2-1 Engine Will Not Crank



#### NOTE

*Park brake switch must be on and transmission lever must be in neutral*

1. Battery cables loose/disconnected	<b>Tighten or connect battery cables</b>
2. Battery Discharged or Defective	<b>Charge battery or replace if defective</b>
3. Open or defective battery disconnect switch S1	<b>Close switch. Replace if defective</b>
4. Loose or broken wire #54 from 94 pin ECU connector (D2.2), pin90 to relay 56ACR	<b>Check continuity. Replace if defective</b>
5. Loose or broken wire #03 to fuse F26	<b>Check continuity. Replace if defective</b>
6. Fuse F26 open	<b>Check for defective wiring. Replace fuse</b>
7. Loose or broken wire #56 from F26 to relay 56ACR	<b>Check continuity. Replace if defective</b>
8. Loose or broken wire #56A from relay 56ACR to 94 pin ECU connector, pin 26	<b>Check continuity. Replace if defective</b>
9. Loose or broken wire #56B from relay 56ACR to fuel pump	<b>Check continuity. Replace if defective</b>
10. Defective relay 56ACR	<b>Check continuity through contacts of relay. Replace if defective</b>
11. Loose or broken ground wire #00 from fuel pump to battery B-	<b>Check continuity. Replace if defective</b>
12. Defective Fuel Pump	<b>Replace if defective</b>
13. Loose or broken B+ wire from battery B+ to ECU fuse F25	<b>Check continuity. Replace if defective</b>
14. ECU 30A fuse F25 open	<b>Check for defective wiring. Replace/repair if defective. Replace fuse</b>
15. Loose or broken wire #K01 from ECU fuse F25 to 94 pin ECU connector 3 places pins 1, 3, and 5	<b>Check continuity. Replace if defective</b>
16. Loose or broken ground wire #00 from battery B- to 94 pin ECU connector 3 places pins 2, 4, and 6	<b>Check continuity. Replace if defective</b>
17. Loose or broken 03 wire from B+ to fuse F1	<b>Check continuity. Replace if defective</b>
18. Fuse F1 open	<b>Check for defective wiring. Replace/repair if defective. Replace fuse</b>
19. Loose or broken 03A wire from fuse F1 to ignition switch SW1	<b>Check continuity. Replace if defective</b>

20. Defective ignition switch SW2	<b>Check for voltage at ST terminal (wire 57) while in start position. Replace if defective</b>
21. Loose or broken 57 wire from ignition switch SW1 to 57DCR starter interrupt relay, pin 30	<b>Check continuity. Replace if defective</b>
22. Loose or broken 60 wire from ignition switch SW1 to 57DCR starter interrupt relay, pin 86	<b>Check continuity. Replace if defective</b>
23. Loose or broken 57D wire from 57DCR starter interrupt relay, pin 85 to Telematics connector pin 9	<b>Check continuity. Replace if defective</b>
24. Without telematics option: Loose or broken jumper at Telematics connector pin 9 to pin 4	<b>Check continuity. Replace if defective</b>
25. With telematics option: Access code may be required, or access may be otherwise limited by machine owner	<b>Input Access code, Contact machine owner</b>
26. Loose or broken ground wire 00 from Telematics 4 to Battery B-	<b>Check continuity. Replace if defective</b>
27. Loose or broken 57A wire from 57DCR starter interrupt relay, pin 87 to park brake switch SW2, pin 5	<b>Check continuity. Replace if defective</b>
28. Defective park brake switch SW2	<b>Check for voltage at pin 6 of switch SW2 (wire 57B) while in start position. Replace if defective</b>
29. Loose or broken 57B wire from park brake switch SW2 pin 6 to 57CCR Neutral enable relay pin 30	<b>Check continuity. Replace if defective</b>
30. Defective ignition switch SW1	<b>Check for voltage at IGN terminal (wire 60) while in run position. Replace if defective</b>
31. Loose or broken wire 60 from ignition switch SW1 to power relay 60CR	<b>Check continuity. Replace if defective</b>
32. Loose or broken wire 03 from B+ to power relay 60CR	<b>Check continuity. Replace if defective</b>
33. Loose or broken wire 00 from power relay 60CR to ground	<b>Check continuity. Replace if defective</b>
34. Defective relay 60CR	<b>Check for voltage at NO contacts of relay (wire 04) with ignition switch SW1 in run position. Replace if defective</b>
35. Loose or broken wire 04 from power relay 60CR to fuse block	<b>Check continuity. Replace if defective</b>
36. Fuse F2 open	<b>Check for defective wiring. Replace fuse</b>
37. Loose or broken 05 wire from fuse F2 to shifter pin 9	<b>Check continuity. Replace if defective</b>
38. Loose or broken 57B wire from park brake switch SW2, pin 6 to transmission shift lever pin 5	<b>Check continuity. Replace if defective</b>



39. Defective transmission shift lever	<b>Check shifter, Replace if defective</b>
40. Loose or broken 57C wire from transmission shift lever pin 2 to 57CCR relay pin 86	<b>Check continuity. Replace if defective</b>
41. Loose or broken 00 wire from 57CCR relay pin 85 to ground	<b>Check continuity. Replace if defective</b>
42. Defective relay 57CCR	<b>Check for voltage at NO contacts of relay with ignition switch SW1 in run position. Replace if defective</b>
43. Loose or broken 57E wire from 57CCR relay pin 87 to engine harness connector (J1) pin 8	<b>Check continuity. Replace if defective</b>
44. Loose or broken 57E wire from engine harness connector (P1) pin 8 to 94 pin ECU connector (D2.2) pin 35	<b>Check continuity. Replace if defective</b>

#### 4.2-2 Engine Cranks But Will Not Run

1. Engine pre-heat circuit inoperative	<b>Refer to Engine manufacturer's manual to diagnose</b>
--	--

#### 4.2-3 Park Brake Will Not Release

1. Fuse F2 open	<b>Check for defective wiring. Replace fuse</b>
2. Loose or broken 05 wire from fuse F2 to park brake switch SW2 pin 2	<b>Check continuity. Replace if defective</b>
3. Defective park brake switch SW2	<b>Check for voltage at pin 1 (wire 26) of park brake switch SW2 with switch in the off position. Replace if defective</b>
4. Loose or broken wire 26 from park brake switch SW2 pin 1 to park brake release relay 05CR pin 30	<b>Check continuity. Replace if defective</b>
5. Loose or broken 05 wire from fuse F2 to park brake release relay 05CR pin 85	<b>Check continuity. Replace if defective</b>
6. Loose or broken 77 wire from park brake release relay 05CR pin 86 to engine harness connector J1 pin 10	<b>Check continuity. Replace if defective</b>
7. Loose or broken 77 wire engine harness connector P1 pin 10 to 94 pin ECU connector D2.2 pin 71	<b>Check continuity. Replace if defective</b>
8. Defective relay 05CR	<b>Check continuity through contacts of relay (pin 30 to 87 with coil energized). Replace if defective</b>
9. Loose or broken 26A wire from park brake release relay 05CR pin 87 to chassis harness connector J31 pin 13	<b>Check continuity. Replace if defective</b>

10. Loose or broken 26A wire from harness connector P31 pin 13 to park brake solenoid 3H-26A	Check continuity. Replace if defective
11. Loose or broken 00 wire from park brake solenoid to ground	Check continuity. Replace if defective
12. Defective brake valve coil 3H-26	Check continuity and resistance through coil. Replace if defective

#### 4.2-4 Forward or Reverse Will Not Engage

1. Loose or broken wire 26A from park brake release relay 05CR pin 87 to 26DCR pin 87	Check continuity. Replace if defective
2. Loose or broken 05 wire from fuse F2 to PS1 common	Check continuity. Replace if defective
3. Loose or broken wire 26D from PSI normally closed contact to 26DCR relay pin 86	Check continuity. Replace if defective.
4. Defective pressure switch PS1	Check that switch is closed normally and opens with 50 PSI. Replace if Defective
5. Loose or broken wire 00 from 26DCR relay pin 85 to ground	Check continuity. Replace if defective.
6. Defective relay 26DCR	Check continuity through contacts of relay (pin 30 to 87 with coil energized). Replace if defective
7. Loose or broken 26E wire from 26DCR relay pin 30 to drive controller pin 4	Check continuity. Replace if defective
8. Loose or broken 207 wire from throttle pedal pin 6 to drive controller pin 21	Check continuity. Replace if defective
9. Loose or broken 00 wire from throttle pedal pin 1 to ground	Check continuity. Replace if defective
10. Loose or broken 03 wire from SW1 to fuse F23	Check continuity. Replace if defective
11. Fuse F23 open	Check for defective wiring. Replace fuse
12. Loose or broken wire from fuse F23 to drive controller pin 6	Check continuity. Replace if defective
13. Loose or broken 03 wire from SW1 to fuse F29	Check continuity. Replace if defective
14. Fuse F29 open	Check for defective wiring. Replace fuse
15. Loose or broken wire from fuse F29 to drive controller pins 9, 10, and/or 19	Check continuity. Replace if defective
16. Loose or broken 00 wire from drive controller pins 7, 18, 28, and/or 29	Check continuity. Replace if defective
17. Defective drive controller	Replace if defective

18. Defective transmission shifter	Replace if defective
------------------------------------	----------------------

#### 4.2-5 No Forward Drive

- |   |  |
|---|--|
| 1. Loose or broken wire 15A from shifter pin 4 to shift controller pin 36         | Check continuity. Replace if defective |
| 2. Loose or broken wire 15 from shift controller pin 36 to 4H-15 reverse solenoid | Check continuity. Replace if defective |
| 3. Loose or broken wire 00 from reverse solenoid to ground.                       | Check continuity. Replace if defective |
| 4. Defective reverse solenoid.  | Replace solenoid                       |
| 5. Defective drive controller.  | Replace if defective                   |
| 6. Defective transmission shifter.  | Replace shifter                        |

#### 4.2-6 No Reverse Drive

- |   |  |
|---|--|
| 1. Loose or broken wire 15A from shifter pin 4 to shift controller pin 36         | Check continuity. Replace if defective |
| 2. Loose or broken wire 15 from shift controller pin 36 to 4H-15 reverse solenoid | Check continuity. Replace if defective |
| 3. Loose or broken wire 00 from reverse solenoid to ground                        | Check continuity. Replace if defective |
| 4. Defective reverse solenoid   | Replace solenoid                       |
| 5. Defective drive controller   | Replace if defective                   |
| 6. Defective transmission shifter   | Replace shifter                        |

#### 4.2-7 Front Steer Mode Only, Fuel gauge inoperative

- |  |  |
|--|--|
| 1. Fuse F3 open  | Check for defective wiring. Replace fuse |
| 2. Loose or broken 05B wire from fuse F3 to fuel gauge B+ post, and steer mode select switch SW4 pin 2 | Check continuity. Replace if defective   |

#### 4.2-8 Front Steer Mode Only

- |  |  |
|--|--|
| 1. Loose or broken 05B wire from fuse F3 to steer mode select switch SW4 pin 2 | Check continuity. Replace if defective |
| 2. Defective Steer mode switch SW4   | Replace if Defective                   |

#### 4.2-9 No 4W (Round) Steer Mode

1. Defective Steer mode switch SW4	Replace if Defective
2. Loose or broken wire 218 from SW4 pin 1 to 4H-218 solenoid	Check continuity. Replace if defective
3. Loose or broken 00 wire from 4H-218 solenoid to ground	Check continuity. Replace if defective
4. Defective 4H-218 solenoid	Replace if Defective

#### 4.2-10 No Crab Steer Mode

1. Defective Steer mode switch SW4	Replace if Defective
2. Loose or broken wire 217 from SW4 pin 3 to 4H-217 solenoid	Check continuity. Replace if defective
3. Loose or broken 00 wire from 4H-217 solenoid to ground	Check continuity. Replace if defective
4. Defective 4H-217 solenoid	Replace if Defective

#### 4.2-11 Function Does Not Switch from Boom Raise/Lower To Carriage Tilt Up/Down With Carriage Tilt Switch SW6 Depressed

5. Fuse F4 open	Check for defective wiring. Replace fuse
6. Loose or broken wire 05C to joystick connector pin 2 and/or frame level enable relay 224CR pin 20	Check continuity
7. Loose or broken wire 224 from connector pin 7 to relay 224CR pin 86	Check continuity. Replace if defective
8. Loose or broken wire 00 from 224CR pin 85 to ground	Check continuity. Replace if defective
9. Relay 224CR defective	Check continuity through contacts of relay (pin 30 to 87a with coil de-energized). Replace if defective
10. Loose or broken wire 47 from 224CR relay pin 87 to carriage tilt enable up and/or down solenoids 4H-47 and/or 4H-47-1	Check continuity. Replace if defective
11. Loose or broken wire 00 from carriage tilt enable up and/or down solenoids 4H-47 and/or 4H-47-1	Check continuity. Replace if defective
12. Carriage tilt up enable solenoid 4H-47 and/or carriage tilt down enable solenoid 4H-47-1 defective	Replace if defective

## 4.3 Hydraulic System

### 4.3-1 All Controls inoperative

1. Worn or defective pump shaft or coupling	Check pump shaft and coupling. Replace if defective
2. Hydraulic oil level low	Check oil level. Fill to proper level
3. Charge pump P1A is defective	Repair or replace if defective
4. RV6 misadjusted or defective	Adjust pressure, replace if defective

### 4.3-2 All Boom Functions Inoperative

1. System pump P2 is defective	Repair or replace if defective
2. RV1 misadjusted or defective	Adjust pressure, replace if defective
3. EC1 defective	Replace if defective

### 4.3-3 No Boom Raise

1. Stuck or defective joystick JS1	Clean valve. Check operation of valve. Repair or replace valve as required
2. Stuck or defective lift valve V4	Clean valve. Check operation of valve. Repair or replace valve as required
3. Stuck or defective lift counterbalance valves CB1	Clean valve. Check O-rings on valve. Repair or replace valve as required
4. Stuck or defective lift counterbalance valves CB2	Clean valves. Check O-rings on valve. Repair or replace valve as required
5. Defective lift cylinder C1	Check seals on cylinder. Replace as necessary. Replace cylinder if defective

### 4.3-4 No Boom Lower

1. Stuck or defective joystick JS1	Clean valve. Check operation of valve. Repair or replace valve as required
2. Stuck or defective lift valve V4	Clean valve. Check operation of valve. Repair or replace valve as required
3. Stuck or defective lift counterbalance valves CB2	Clean valve. Check O-rings on valve. Repair or replace valve as required

4. Stuck or defective lift counterbalance valves CB1	Clean valves. Check O-rings on valve. Repair or replace valve as required
5. Defective lift cylinder C1	Check seals on cylinder. Replace as necessary. Replace cylinder if defective

#### 4.3-5 No Telescope Extend

1. Stuck or defective joystick JS1	Clean valve. Check operation of valve. Repair or replace valve as required
2. Stuck or defective extension valve V1	Clean valve. Check operation of valve. Repair or replace valve as required
3. Stuck or defective extension counterbalance valves CB4	Clean valve. Check O-rings on valve. Repair or replace valve as required
4. Stuck or defective lift counterbalance valves CB5	Clean valves. Check O-rings on valve. Repair or replace valve as required
5. Defective telescope cylinder C4	Check seals on cylinder. Replace as necessary. Replace cylinder if defective

#### 4.3-6 No Telescope Retract

1. Stuck or defective joystick JS1	Clean valve. Check operation of valve. Repair or replace valve as required
2. Stuck or defective telescope valve V1	Clean valve. Check operation of valve. Repair or replace valve as required
3. Stuck or defective lift counterbalance valves CB5	Clean valve. Check O-rings on valve. Repair or replace valve as required
4. Stuck or defective lift counterbalance valves CB4	Clean valves. Check O-rings on valve. Repair or replace valve as required
5. Defective telescope cylinder C4	Check seals on cylinder. Replace as necessary. Replace cylinder if defective

#### 4.3-7 No Carriage Tilt Up

1. Stuck or defective joystick JS1	Clean valve. Check operation of valve. Repair or replace valve as required
2. 4H-47 stuck or defective	Clean valve. Check operation of valve. Repair or replace valve as required
3. Stuck or defective carriage tilt valve V3	Clean valve. Check operation of valve. Repair or replace valve as required
4. RV5 misadjusted or defective	Adjust pressure, replace if defective

5. Stuck or defective lift counterbalance valves CB3	Clean valve. Check O-rings on valve. Repair or replace valve as required
6. Defective carriage tilt cylinder C2	Check seals on cylinder. Replace as necessary. Replace cylinder if defective
7. Defective tilt compensation cylinder C3	Check seals on cylinder. Replace as necessary. Replace cylinder if defective

#### 4.3-8 No carriage Tilt Down

1. Stuck or defective joystick JS1	Clean valve. Check operation of valve. Repair or replace valve as required
2. 4H-47-1 stuck or defective	Clean valve. Check operation of valve. Repair or replace valve as required
3. Stuck or defective carriage tilt valve V3	Clean valve. Check operation of valve. Repair or replace valve as required
4. RV4 misadjusted or defective	Adjust pressure, replace if defective
5. Stuck or defective lift counterbalance valves CB3	Clean valve. Check O-rings on valve. Repair or replace valve as required
6. Defective carriage tilt cylinder C2	Check seals on cylinder. Replace as necessary. Replace cylinder if defective
7. Defective tilt compensation cylinder C3	Check seals on cylinder. Replace as necessary. Replace cylinder if defective

#### 4.3-9 No Aux. Functions

1. 4H-237A/4H-237A-1 stuck or defective	Clean valve. Check operation of valve. Repair or replace valve as required
2. Stuck or defective Aux. valve V2	Clean valve. Check operation of valve. Repair or replace valve as required
3. RV2 and/or RV3 misadjusted or defective	Adjust pressure, replace if defective
4. Stuck or defective Auxiliary counterbalance valve (if equipped)	Clean valve. Check O-rings on valve. Repair or replace valve as required
5. Defective Auxiliary/Optional cylinder(s)	Check seals on cylinder. Replace as necessary. Replace cylinder if defective

#### 4.3-10 Hard or No Steering

1. Stuck or defective EC1 valve	Clean valve. Check operation of valve. Repair or replace valve as required
2. Stuck or defective shuttle valve SV1	Clean valve. Repair or replace valve as required
3. Stuck or defective steering motor OSM1	Check O-rings and clean valve. Repair or replace orbit motor as required

4. Defective steer cylinder C5 and/or C6	Check seals on cylinder. Replace as necessary. Replace cylinder if defective
5. Orifice OR1 plugged	Remove and inspect, clean or replace as required
6. Relief valve RV14 valve defective	Check O-rings and clean valve. Repair or replace orbit motor as required
7. Orifice OR2 plugged	Remove and inspect, clean or replace as required

#### 4.3-11 Park Brake will not Release

1. Stuck or defective park brake valve 3H-26	Clean valve. Check O-rings on valve. Repair or replace valve as required
2. Bypassing or defective parking brake seals in axle	Check seals, replace as necessary. Replace if defective

#### 4.3-12 Park Brake Will Not Engage

1. Defective park brake C11	Repair or replace as necessary
2. Park brake valve SV3 stuck in shifted position	Check valve. Replace if defective

#### 4.3-13 Service Brake Will Not Engage

1. Service brake actuator stuck or defective	Clean valve. Check operation of valve. Repair or replace valve as required
2. Stuck or defective shuttle valve SV1	Clean valve. Repair or replace valve as required
3. Bypassing or defective brake seals in axle	Check seals, replace as necessary. Replace if defective

#### 4.3-14 No Drive Function Forward or Reverse

1. Defective pump displacement control 4H-15 and 4H-16	Check control. Replace if defective
2. Worn or defective drive pump P1	Check pump. Replace if defective
3. Worn or defective drive motor M1	Check motor. Replace if defective
4. Service brake V12 not releasing	Check brake pedal is returning to up (off) position. Clean, repair or replace valve as required
5. Park brake not releasing	See “park brake will not release” in this section



---

### 4.3-15 No Forward Drive

---

1. Defective pump displacement control 4H-16	<b>Check control. Replace if defective</b>
2. Defective or misadjusted drive relief valves RV11, RV7, or RV9	<b>See section 5 for drive pump set up procedures. Adjust, repair, or replace as required</b>
3. Worn or defective drive motor M1	<b>Check motor. Replace if defective</b>

---

### 4.3-16 No Reverse Drive

---

1. Defective pump displacement control 4H-15.	<b>Check control. Replace if defective</b>
2. Defective or misadjusted drive relief valves RV12, RV8, or RV10	<b>See section 5 for drive pump set up procedures. Adjust, repair, or replace as required</b>
3. Worn or defective drive motor M1	<b>Check motor. Replace if defective</b>

---

To order go to Discount-Equipment.com

# Section 5 – Procedures

## 5.1 General

The following information is provided to assist you in the use and application of servicing and maintenance procedures contained in this chapter.

### 5.1-1 Safety and Workmanship

Your safety, and that of others, is the first consideration when engaging in the maintenance of equipment. Always be conscious of weight. Never attempt to move heavy parts without the aid of a mechanical device. Do not allow heavy objects to rest in an unstable position. When raising a portion of the equipment, ensure that adequate support is provided.

### 5.1-2 Engine and Transmission

The engine used on the SJ519 TH telehandler models is a Deutz TCD 2.2L Tier 4 Final.

Engine service information can be found in the Deutz Engine Manuals. It should be noted that engine warranty service work is to be directed to and administered by your nearest authorized Deutz dealer/distributor.

Skyjack cannot enter into any warranty service work requirements.

The basic Deutz engine warranty covers the entire engine from the fan to the fly wheel including all internal parts as well as the following list of parts supplied with the engine as original:

- Electronic Data Display Module
- Starter
- Alternator
- Injectors
- Fuel Pump
- Fuel Solenoid
- Water Pump
- Radiator

The air cleaner and exhaust system, cooling system including radiator and hoses are not part of the engine package, and are covered later in this manual.

## 5.2 10 Hour or Daily Routine Maintenance

Perform maintenance inspections for the items described in this section on a daily basis or at the start of each work shift.

### 5.2-1 Check Engine Oil Level

1. Park telehandler on a firm level surface with boom fully retracted and lowered.
2. Shut off engine then release latch and lift engine cover to open.
3. Wait approximately 15 minutes after engine has been shut off.
4. Pull out dipstick and wipe it off with a clean, dry, lint-free cloth; then place it back in the hole until it stops.

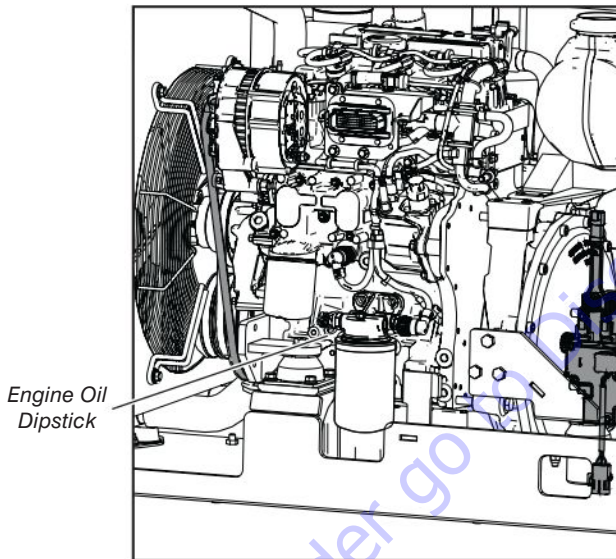

Figure 01 Engine Oil Dipstick

5. Pull the dipstick out again and check the oil level on the dipstick. The oil level must be between the “Full” and “Low” marks.
6. If oil level is below the “Low” mark, refer to [5.4-4 Replace Engine Oil and Filter](#) for engine oil and filter replacement procedure.

### 5.2-2 Check Coolant Level, Radiator and Hoses

#### **WARNING**

**Pressurized fluid present in radiator. Never open radiator cap when hot.**

#### **NOTE**

*Do not intermix different brands of coolant. If the existing coolant cannot be identified, drain and flush the remaining coolant and refill with new coolant. Refer to [5.5-5 Change Engine Coolant](#) for instructions on changing engine coolant.*

1. Remove radiator cap.
2. Fill radiator completely through the radiator neck, until coolant is visible. See figure below.

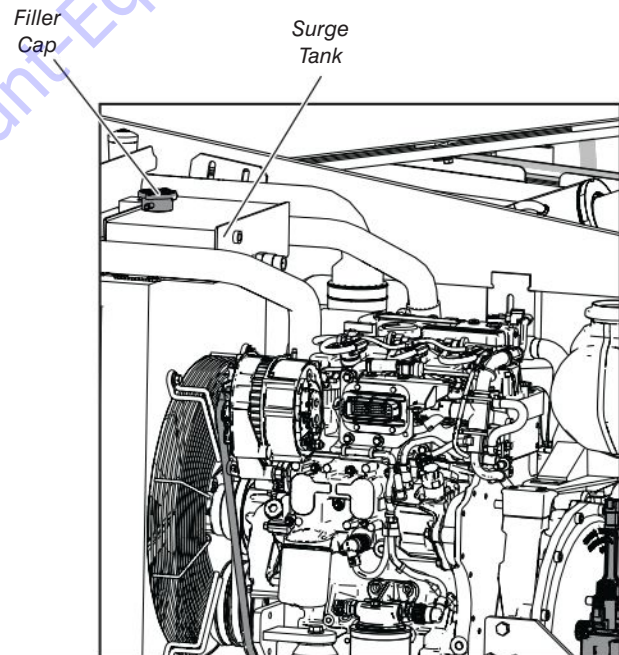

Figure 02 Surge Tank Location

3. Run the engine for 25 minutes without radiator cap to achieve operating temperature. Shut down the engine.
4. Check coolant level in the radiator. Refill until coolant is visible.
5. Install radiator cap.

### 5.2-3 Check Air Cleaner Restriction and Filter Elements

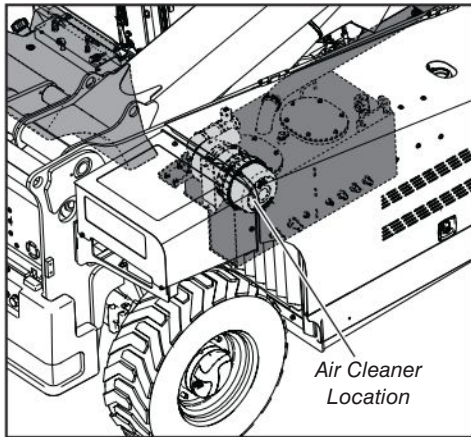

Figure 03 Air Cleaner Location

1. Service the air cleaner when a red band appears on the service indicator. After servicing, press the indicator to reset it.
2. Check the air cleaner vaccuator valve to see that it is clean and that the rubber is not cracked. Squeeze the valve lips and remove any dirt or dust. It should expel dust and dirt continuously when the engine is running. See figure below.

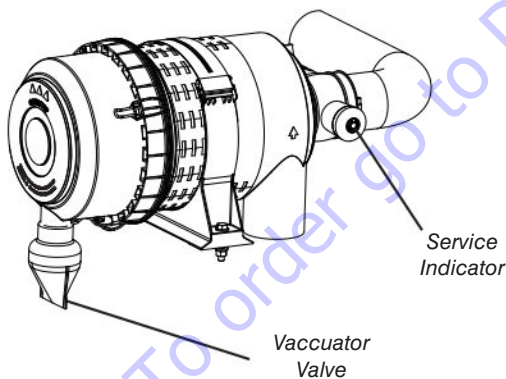

Figure 04 Air Cleaner Vaccuator Valve



#### NOTE

SJ519 TH telehandlers are equipped with a two-stage air filter system; which consists of a primary filter element & a secondary safety element. Inspect the condition of both the primary and safety elements.



#### IMPORTANT

The primary element can be replaced or cleaned. The secondary element cannot be cleaned and must be replaced only.



#### NOTE

For maximum engine protection, replace the secondary element after every third cleaning of the primary element or annually.

1. Undo latches and pull cover outward to remove.

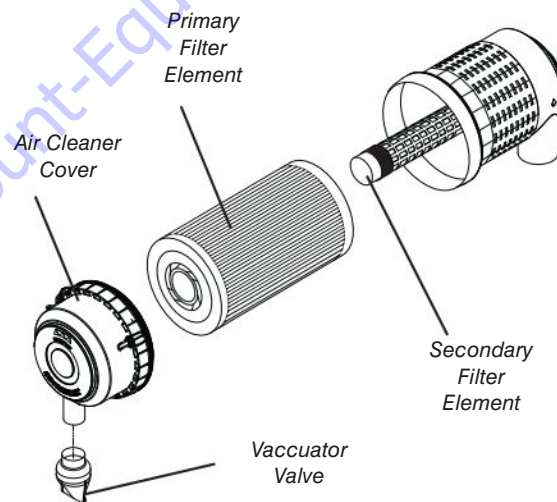

Figure 05 Engine Air Cleaner

2. Remove the primary air cleaner element. Clean or replace as required.
3. With the Secondary element in place, clean inside the housing and the cover with a damp cloth.



#### CAUTION

Never use compressed air on an air filter. Paper elements should not be “washed”.

**NOTE**

Secondary or safety element should not be removed unless it is being replaced.

**Replace the secondary element if:**

- Examination reveals tears or perforations in the safety element.
- The primary element has been replaced three times or the element has been in service one year.

**5.2-4 Check Hydraulic Oil Level**

Maintaining the hydraulic components and hydraulic oil at the proper level are essential to good performance and service life of the telehandler.

The telehandler must be on level ground and all cylinders retracted when checking oil level.

Refer to oil sight gauge at the right side of the inner frame and check that the hydraulic fluid is between MAX and MIN.

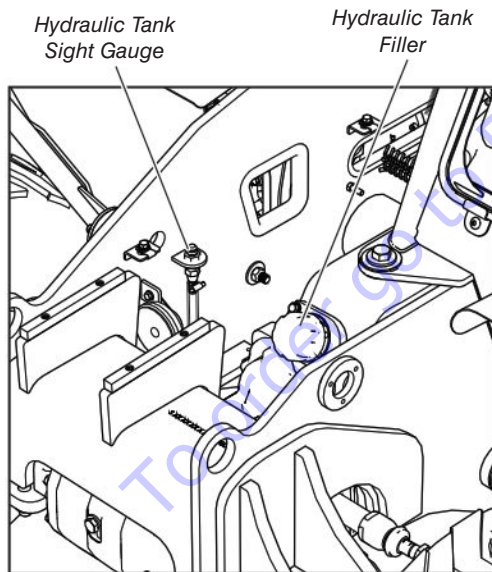

**Figure 06** Hydraulic Oil Tank Sight Gauge

1. Check hydraulic Oil Tank Sight Gauge.
2. Add clean hydraulic oil through the tank filler as required. Refer to [2.4 Recommended Fluids/Lubrications](#) for hydraulic oil specifications.

**5.2-5 Drain Fuel/Water Separator****WARNING**

**Diesel fuel is flammable and may cause death or serious injury. Shut down engine and do not smoke while draining fuel/water separator.**

1. Ensure engine is shut down & telehandler is parked on a firm level surface.
2. Prepare a container for draining the fuel/water separator and place it under the separator.
3. Open drain reservoir and allow approximately one cup of fuel and any collected sediment to drain into the container. Refer to the Figure below.
4. Close the drain then dispose of the collected liquid in an environmentally safe manner.

**NOTE**

Refer to your local/national environmental regulations on how to dispose of used fuels and other dangerous liquids.

**5.2-6 Fuel Tank****WARNING**

**Do not allow fuel tank to become completely empty. If tank is allowed to empty completely, the entire fuel system will require bleeding.**

1. Check fuel gauge inside operator's cab.
2. Ensure fuel is at an appropriate level before the start of each work shift.
3. Add diesel fuel as required.

**NOTE**

Refer to Operating Manual for refueling procedure.

**5.2-7 Check Parking Brake**

1. Check the park brake operation daily or every 10 hours of service.



**NOTE**

Refer to “Park Brake Test Procedure” in Section 2 of Operating Manual.

**5.2-8 Check Tire Pressure and Condition**

1. Check the tire pressure when cold and inflate to the recommended pressure. Refer to Operating Manual for tires and tire pressure specifications.



**WARNING**

**Do not over-inflate. Tire may explode causing death or severe injury.**

2. Remove wheel from telehandler to fill the tire whenever pressure is below 80% of the recommended pressure.
3. Place tire in a cage and inflate using a clip-on chuck and a remote tire pressure gauge.
4. If tire must be removed for repairs, remove the air pressure from the tire before removing the wheel from the telehandler.

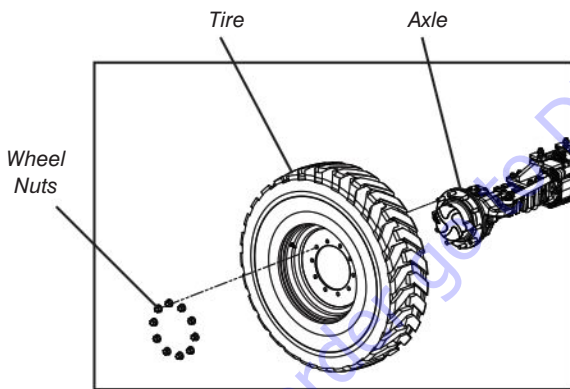

Figure 07 Telehandler Wheel

5. Check tire tread for damage. Check for bent or damaged rims and loose or missing hardware.
6. Tighten and torque wheel nuts.

**5.2-9 Check Seat Belt and Mounting Hardware**

1. Check seat belt for wear or damage. Check that mounting hardware is tight.

2. Inspect the belt hardware and fabric. Replace if hardware is damaged, frayed or loose stitching is found.



Figure 08 Seat Assembly



**NOTE**

Replace seat belt assemblies every three (3) years, regardless of appearance. Seat belt strength degrades over time and use due to exposure to weather conditions.

**5.2-10 Check Windshield Washer Fluid Level and Wiper Condition**

1. Check fluid level in washer bottle. Add as required.
2. Check the condition of the windshield wiper and replace if necessary.

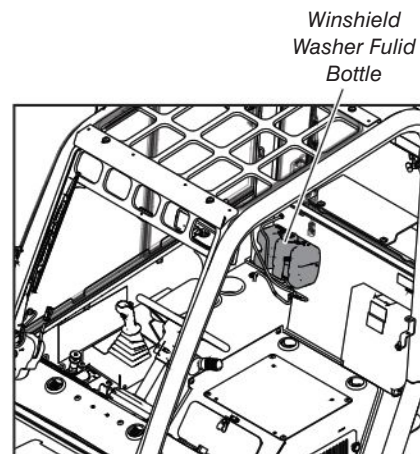

Figure 09 Windshield Washer Fluid.

## 5.3 50 Hour or Weekly Routine Maintenance

### 5.3-1 Grease Axle Pivot Bearings and King Pins

Each axle has two integral pivot assemblies which attach the axle to the frame. Each of the four pivot assemblies requires independent lubrication.

#### ▪ Axle Pivot Bearings

There are remote grease fittings for pivot bearing lubrication..

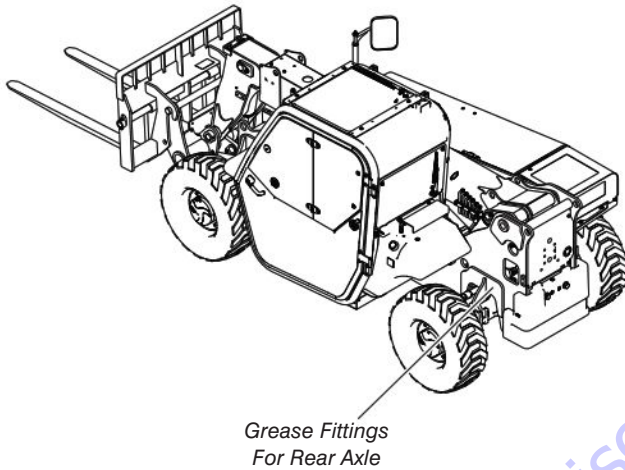

**Figure 10** Front Axle Pivot Bearing Grease Fittings

The rear axle remote grease fittings are located beside the tilt compensation cylinder. See figure above.

1. Wipe dirt and grease from each remote grease fitting.
2. Remove cap and apply 4 shots of grease to each fitting.

#### ▪ Axle King Pins

Each axle has two king pins. Each king pin has an upper and a lower grease fitting (total of 4 king pins on each axle). Follow the steps below to lubricate the king pins.

1. Wipe each fitting clean.
2. Apply 4 shots of grease to each fitting. See figure below.

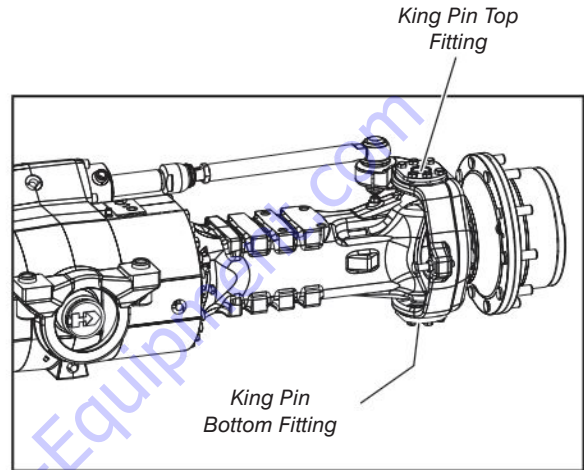

**Figure 11** Axle King Pins

### 5.3-2 Grease Drive Shaft U-joints and slip joints

1. Wipe each fitting clean.
2. Apply 4 shots of grease to each fitting. See figure below.

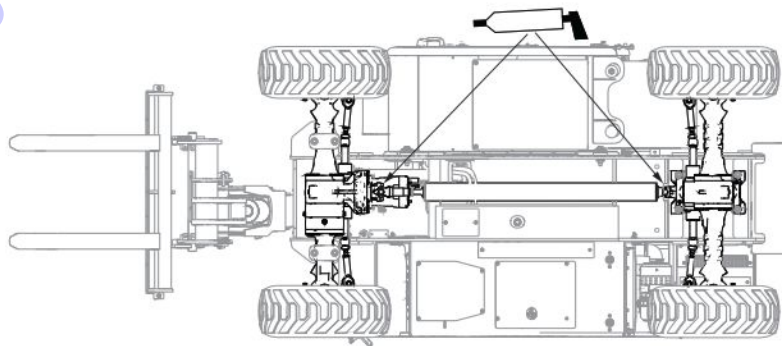

**Figure 12** Drive Shaft Grease Points

### 5.3-3 Check Fork Pins

1. Check the condition of the fork pin.
2. Inspect for cracks and other deformations.
3. Replace if required.

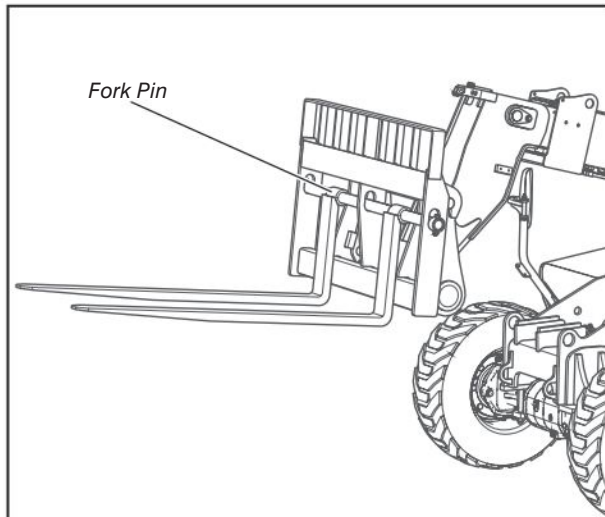

**Figure 13 Fork Pin**

### 5.3-4 Wear Pads Greasing

1. Ensure telehandler is parked on a firm level surface.
2. Move the shift lever to neutral and engage park brake.
3. Fully extend the boom to gain access to front bottom wear pads.
4. Shut down the engine and dismount from cab.
5. With boom fully extended, smear grease along the path of front wear pads.

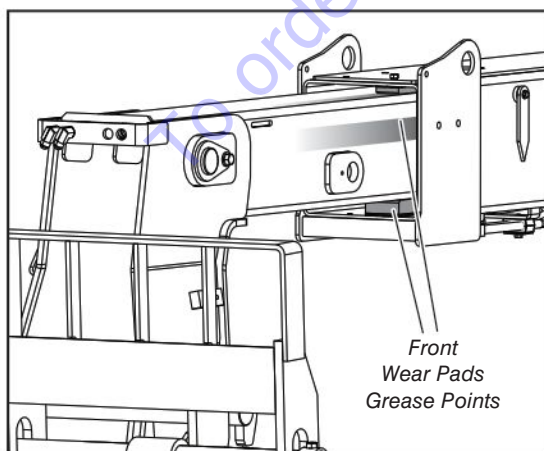

**Figure 14 Front Wear Pads**

6. With boom fully extended, remove rear cover to gain access to top rear slide pads.
7. Smear grease along the path of rear top slide pads.
8. Fully retract the boom then fully extend it a few times to ensure the path of slide pads is covered with grease for maximum protection.

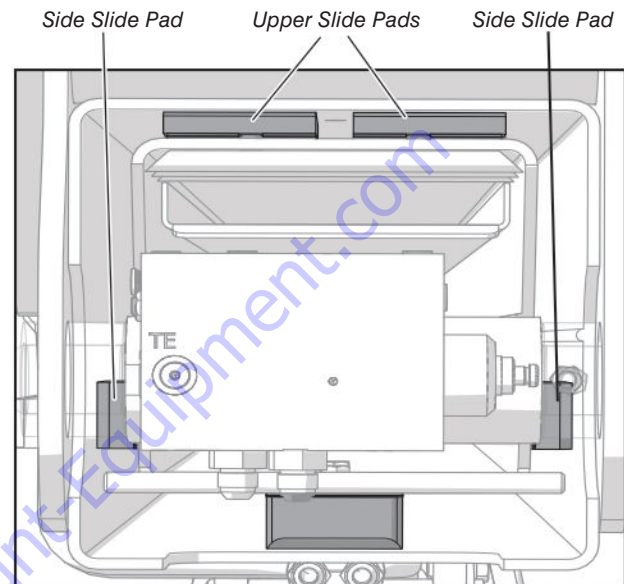

**Figure 15 Rear Wear Pads**

9. Shut down the engine and remove key.



## 5.4 250 Hour or Quarterly Routine Maintenance

### 5.4-1 Check Lug Nut Torque

1. Ensure wheel nuts are tight on all wheels.
2. Tighten wheel nuts to a torque of 325 ft-lb (441 N·m) using the cross pattern shown in figure below.

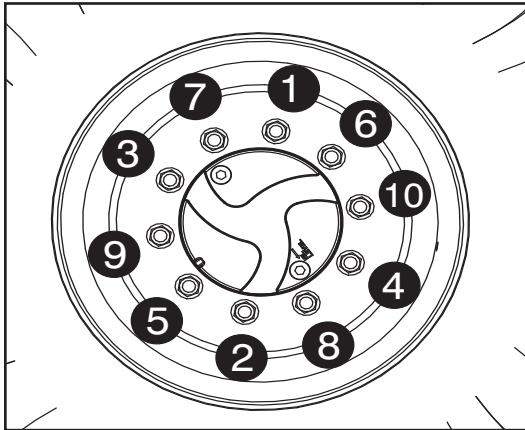

Figure 16 Wheel Nuts Torque Procedure

3. When the wheels are removed and reinstalled, check the nuts after eight (8) hours of operation.
4. If nuts are tight after the eight hour check, the interval for checking with a torque wrench can be extended to 250 hours.

### 5.4-2 Check Oil Level in Axle Differential Planetary wheel Ends

#### **WARNING**

Hot oil or components can burn. Oil must be at normal operating temperature when draining. Avoid contact with hot oil or components.

#### **NOTE**

Each axle has two independent planetary assemblies that require gear oil lubricant.

1. Park telehandler on a firm level surface with the fill plug in the vertical position as shown in figure below.

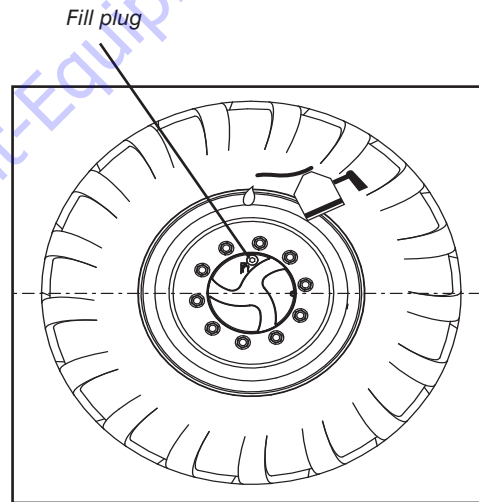

Figure 17 Planetary Wheel Plug

2. Apply park brake and shut off engine and allow telehandler to sit for a minimum of two minutes.
3. Wipe the fill plug clean and remove.
4. Check oil level at the bottom of the fill hole. If required, add oil.

#### **NOTE**

Refer to [2.4 Recommended Fluids/Lubrications](#) in this manual for oil type and capacity.

5. Re-install plug and repeat steps above for the three (3) remaining planetary wheel ends.

### 5.4-3 Check Oil level in Axle differentials



#### NOTE

Each axle assembly requires gear lubricant independent of the planetary assemblies.

1. Ensure telehandler is parked on a firm level surface.
2. Apply park brake and turn off engine, then allow it to sit for a minimum of two minutes.
3. Wipe Level/Fill plug clean and remove. See figure below.

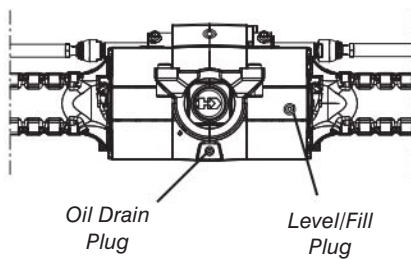

Figure 18 Axle Plugs

4. Check oil level at the bottom of the fill hole. Add oil as needed.



#### NOTE

Refer to [2.4 Recommended Fluids/Lubrications](#) in this manual for oil type and capacity.

5. Re-install plug and repeat steps above for the other axle.

### 5.4-4 Replace Engine Oil and Filter

Maintaining the engine components is essential to good performance and service life of the telehandler.

Periodic replacement of the engine oil and filter is essential to good engine performance.



#### NOTE

Shut off engine and allow it to cool down prior to performing this procedure.

#### CAUTION

Beware of hot engine components. Contact with hot engine components may cause severe burns.

#### CAUTION

When draining hot oil, there is a risk of scalding. Do not let used oil run into the soil, rather collect it in a container. Dispose of this in accordance with environmental regulations.

1. Ensure telehandler is parked on a firm level surface.
2. Apply park brake and remove key from ignition switch.
3. Allow engine to cool down.
4. Unlatch engine cover and lift it to gain access to engine compartment.
5. Place a container capable of holding approximately 7 quarts (7.4 litres) under engine oil drain plug.

- Remove oil drain plug and allow all engine oil to drain into container. See figure below.

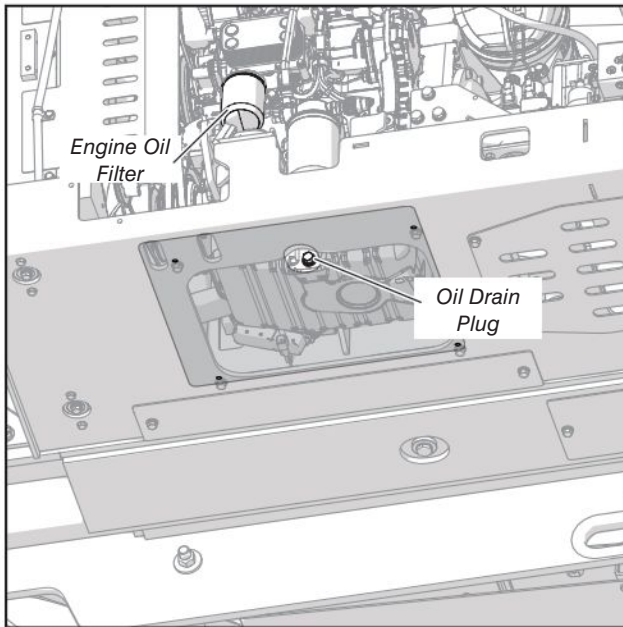

**Figure 19** Engine Oil Draining

- Install oil drain plug with a new seal ring and tighten firmly.
- Remove oil filter and catch any escaping oil.
- Clean inside the filter head.
- Apply a thin layer of engine oil to the new oil filter gasket.
- Screw on new filter by hand until the gasket is touching then tighten to a torque of 7-9 ft.-lb. (10-12 Nm).
- Clean up any oil that may have spilled during this procedure.

- Refill engine with new oil through the fill area. Refer to [2.4 Recommended Fluids/Lubrications](#).

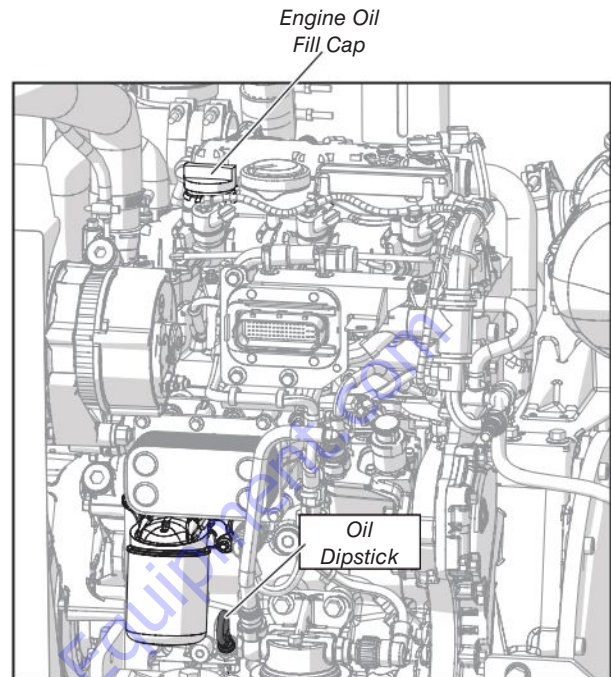

**Figure 20** Engine Oil Fill Cap

- Start engine and allow it to run for 30 seconds then stop the engine.
- Check for oil leakage.
- Check engine oil level on dipstick and add oil if needed.
- Close the engine compartment cover then latch to secure in place.



**NOTE**

Refer to your local/national regulations on how to dispose of used filter and oil.

### 5.4-5 Change Engine Fuel filter and Fuel/ Water Separator

The engine has both a fuel filter and a fuel/water separator to filter water, rust particles, dust and other particles from the fuel. See figure below.

#### **WARNING**

**The fuel pump high-pressure fuel lines and fuel rail contain very high pressure fuel. Never loosen any fittings while the engine is running. Personal injury and property damage can result.**

1. Ensure telehandler is on firm level surface.
2. Apply parking brake, shut down the engine and remove key from ignition switch.
3. Unlatch engine compartment cover and lift it up.
4. Clean area around fuel filter and fuel/water separator.
5. Place a container under filter and separator to collect any escaping fuel when removing them.
6. Disconnect the water level sensor harness from fuel/water separator.
7. Unscrew the drain plug assembly from bottom of water separator.
8. Unscrew used fuel filter and separator. Discard used filter and separator and any captured spilled fuel.

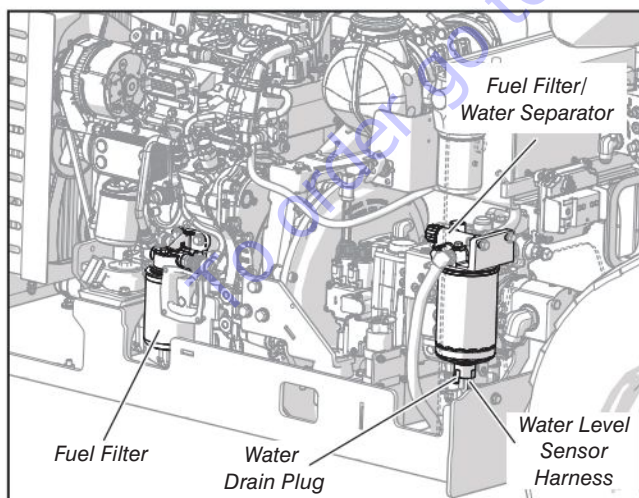
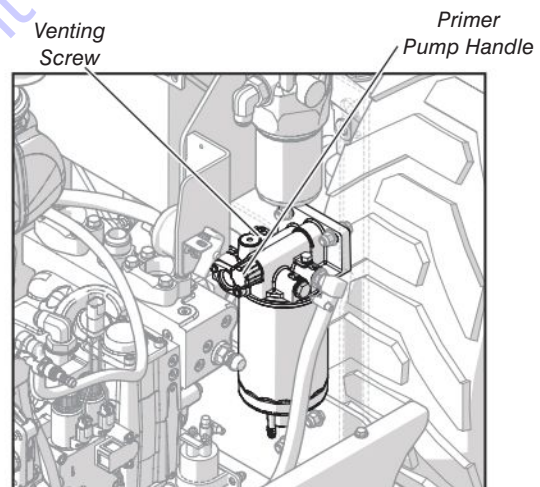

**Figure 21 Fuel Filter & Water Separator**

#### **NOTE**

Refer to your local/national regulations on how to dispose of used filter and separator.

9. Clean the sealing surface of the new filter cartridge and opposite side of filter head. If necessary, replace O-ring on the filter head.
10. Lubricate O-ring seal and the sealing surface slightly with fuel.
11. Install replacement filter and separator as specified by manufacturer. Most filters have instructions printed on the side. Torque to 13 ft.-lb. (17-18 Nm)
12. Mount the drain plug on bottom of water separator. Torque to 1 ft.-lb. (1.6 ± 0.3 Nm)
13. Check area around filter and separator for any leaks.
14. Connect water level sensor harness to fuel/water separator.
15. Prime fuel system after fuel filters have been reinstalled as follows: Refer to figure below.



**Figure 22 Priming the Fuel System**

## **⚠ WARNING**

**Do not attempt to start the engine while the fuel system is venting to ensure no error messages are generated.**

- Loosen venting screw.
  - Turn the primer pump handle counter clockwise (CCW) to release.
  - Pump the handle in and out until pressure builds in the fuel system (handle will gradually become firm and fuel will come out of venting plug).
  - Retighten venting screw and primer handle.
16. Check area for any leaks.
17. Close engine cover back and latch it in place.

### 5.4-6 Clean Hydraulic Tank Breather

1. Clean area around hydraulic breather. Do not allow dirt to enter the hydraulic tank.

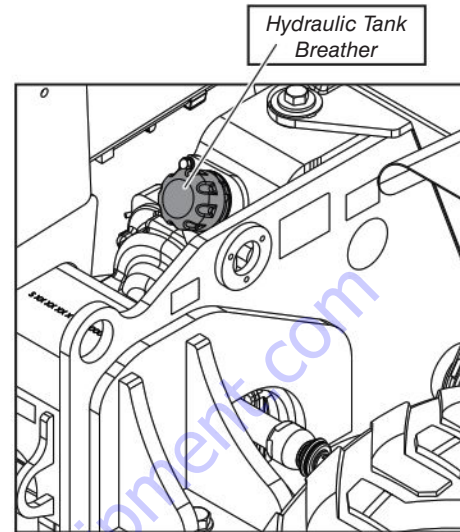
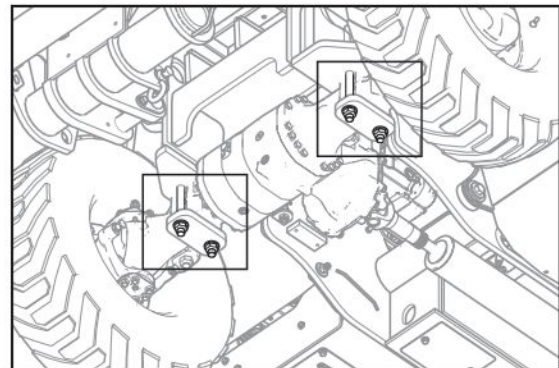

**Figure 23** Hydraulic Tank Breather

2. Remove the breather and clean with solvent. Blow dry with compressed air.
3. Install the cleaned breather on the tank.

### 5.4-7 Torque Axle Mounting Bolts

The axles are secured to the frame by an axle pivot assembly on each side of the axle. The pivot assemblies are bolted to the machine frame with axle mounting bolts. See figure below.



**Figure 24** Axle Mounting Bolts

1. Torque front axle mounting bolts to 320 ft·lb. (434 N·m.).
2. Torque rear axle mounting bolts to 320 ft·lb (434 N·m.).

### 5.4-8 Check Boom Wear Pad Clearances

Wear pads support the boom components as the boom is extended and retracted. The wear pads must maintain clearance between the contact surface of the pad and the adjacent sliding surface. This clearance ranges between 0.031 – 0.062 in. (0.79 – 1.58 mm) TOTAL for both sides of the boom. When clearances exceed this amount, shims need to be added or the pads must be replaced.

The wear pads are chamfered on the corner of the wear surface. This serves as a wear indicator. When the chamfer is no longer visible, replace the pads. Additional wear will allow interference with inserts in the pads. Refer to [5.6-1 Wear Pads Replacement Procedure](#) for slide pads replacement procedure.

Lubrication of the pads require application of grease on the boom surfaces which come in contact with the pads.

1. Park telehandler on a firm level surface.
2. Extend the boom and rest the forks on a level surface.
3. Apply park brake then shutdown the engine and remove key from ignition switch.
4. Measure the clearance between the bottom surfaces of the inner boom and the wear pads.

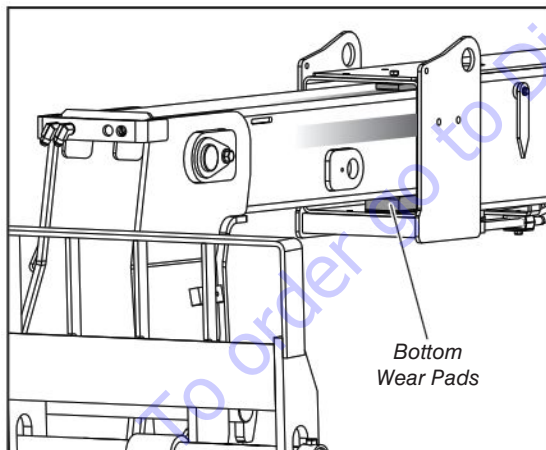

**Figure 25** Bottom Slide pads

5. Clearance should not exceed 0.08 in. (2 mm). When clearances exceed this amount, add shims or replace the pads.
6. Start the engine and raise the boom off the level surface ensuring there is no upward force applied to the boom.
7. With park brake applied, shut down engine and remove key from ignition switch.

8. Measure the clearance between each side wear pad and the boom at each section as follows:
  - Place a bar against the side of the boom section and pry the section sideways as far as possible.
  - Measure the clearance between the side of the boom and the side wear pads. Clearance should not exceed 0.08 in. (2 mm).

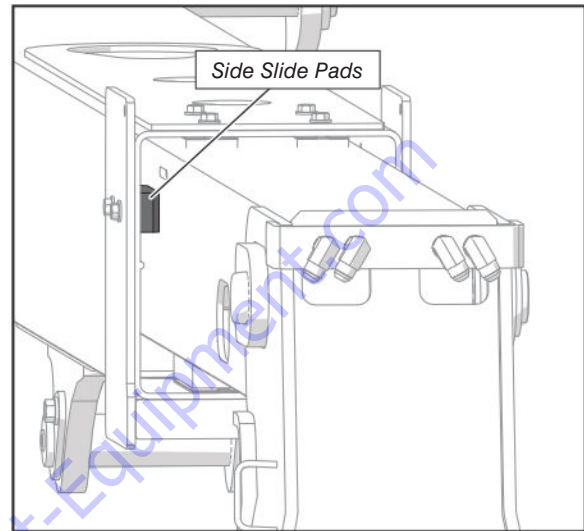

**Figure 26** Side Slide Pads Clearance

9. Remove rear access cover so that rear of the boom is visible.
10. Start the engine and fully retract the boom so that upper and side slide pads on each boom section are visible. See figure below.

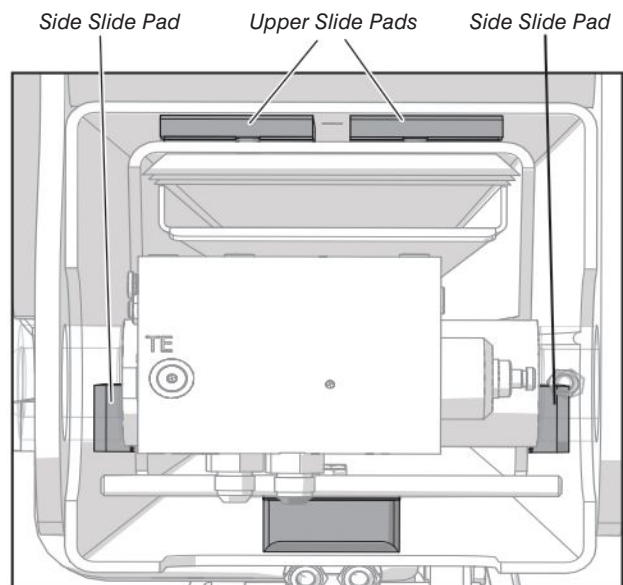

**Figure 27** Rear Upper and Side Slide Pads

11. Lower the boom until the forks are resting on the ground and an upward force is being applied to the boom sections.
12. Shut off the engine and remove key.
13. Measure the slide shoe clearance at the top of each boom section. Clearance should range not exceed 0.025 in. (0.63 mm).
14. Start the machine and raise the boom high enough to lift the forks off the ground.
15. Shut off the engine.
16. Measure the side slide pads clearance using the same procedure as outlined in step 8 for the side slide pads at the front of the boom.
17. If clearances are within 0.08 in. (2 mm), install the rear boom cover.

**NOTE**

*If any of the clearances are greater than 0.08 in. (2 mm), shim adjustment or replacement of the slide pads may be required.*

## 5.5 1000 Hour or Annual Routine Maintenance

### 5.5-1 Change Hydraulic Oil Filter

1. Ensure telehandler is on a firm level surface, apply the park brake and shut down the engine.
2. Unlatch engine compartment cover and lift up to gain access to Hydraulic Oil Filter.
3. Place suitable container under filter to catch any spilled oil.
4. Unscrew and discard old filter. Be sure all traces of the old filter gasket are removed from the filter head.

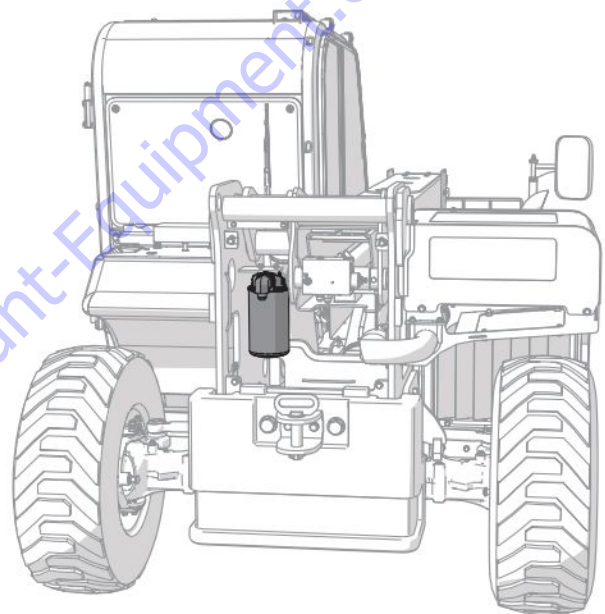

**Figure 28** Hydraulic Oil Filter Location

**NOTE**

*Refer to your local/national regulations on how to dispose of used hydraulic oil filter.*

5. Apply a light coating of clean oil to the gasket on the new filter.
6. Install the new filter and turn until the gasket contacts the filter head.
7. Tighten an additional 1/2 to 3/4 turn by hand to compress the gasket.

### 5.5-2 Change Hydraulic Oil and Clean Hydraulic Tank

#### NOTE

*Dirt in the hydraulic system will lead to premature component failure. A clean, contaminant-free system is extremely important to the telehandler's proper function. Take extra care when working around or on the hydraulic system to ensure its complete cleanliness.*

1. Park telehandler on a firm level surface.
2. Fully retract and lower the boom to the stowed position.
3. Apply parking brake and shutdown the engine.
4. Place a container under the hydraulic oil tank capable of holding approximately 45 gallons (170 Litres).
5. Remove hydraulic tank drain plug from under hydraulic oil tank and allow all hydraulic oil to drain into container.

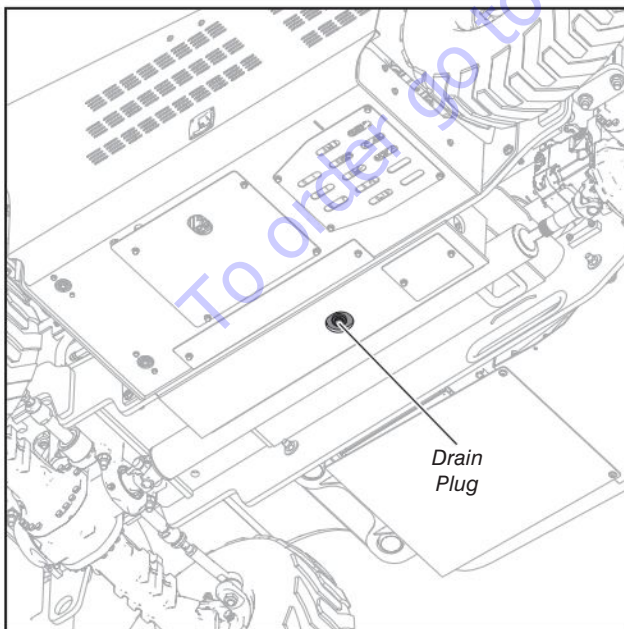
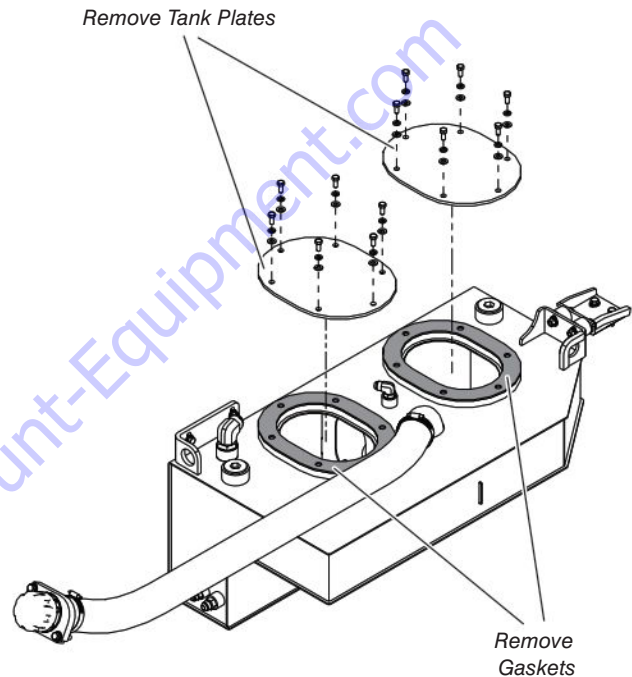

**Figure 29** Hydraulic Tank Drain Plug

#### NOTE

*Refer to your local/national regulations on how to dispose of used hydraulic oil.*

6. Remove tank filler breather and set aside.
7. Remove 12 screws holding the access cover plate from top of tank.
8. Remove rubber gaskets under the access cover plates and set aside.



**Figure 30** Tank Hose Removal

9. Clean the tank with a lint-free cloth or a similar shop rag ensuring all dirt and dust particles are removed.

#### NOTE

*Follow shop practice standards for flushing and cleaning of hydraulic oil tank.*

10. Install drain plug back into tank. Replace O-ring seal if needed.



**NOTE**

Refer to [2.4 Recommended Fluids/Lubrications](#) for hydraulic oil specifications and tank capacity.

11. Refill the hydraulic tank with new oil from unopened container.
12. Check for leakage.
13. Install cover plate and tank filler breather.
14. Clean up any oil that may have spilled during this procedure.
15. Check hydraulic oil level. (They hydraulic oil level should be at or slightly above the top mark on the sight gage)
16. Start engine and work hydraulic functions.
17. Check hydraulic oil level again through the sight gauge. Add additional oil as required.

**5.5-3 Change Axle Differential Oil**

Each axle assembly requires gear lubricant independent of the planetary assemblies.

**WARNING**

**Hot oil or components can burn. Oil must be at normal operating temperature when draining. Avoid contact with hot oil or components. Do not allow oil to drain into the ground.**

1. Ensure that the axle differential oil is at normal operating temperature.
2. Park the machine on a firm level surface, apply parking brake, shut off the machine, and allow it to sit for two minutes.
3. Place a container capable of holding approximately 10 quarts (9.5 liters) under axle drain plugs.

4. Clean the areas around the three (3) drain plugs and level/fill plug, and remove the level/fill plug.

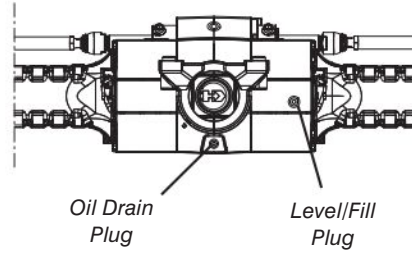

**Figure 31 Axle Plugs**

5. Remove all three (3) drain plugs and drain the oil from the differential. Dispose of used oil in accordance with local regulations.

**NOTE**

Refer to your local/national regulations on how to dispose of used oil.

6. Wipe off the magnetic drain plugs with a clean rag and install them in the axle.
7. Slowly fill the axle with 7 quarts (6.6 liters) of gear oil until oil begins to overflow from the level/fill hole. Refer to [2.4 Recommended Fluids/Lubrications](#) for axle differential oil specifications.
8. Clean and replace the level fill plug.
9. Repeat procedure for the second axle

**5.5-4 Change Axle Planetary Oil**

Each axle assembly requires planetary gear lubricant independent of the differential assemblies.

1. Ensure that the axle planetary oil is at operating temperature.
2. Park the telehandler on a firm level surface with the level/fill/drain plug at the 6 o'clock position.
3. Shut down the engine, apply parking brake, and allow it to sit for a minimum of two minutes.

- Clean the area around the plug and remove it, then drain the axle oil into a container.



Figure 32 Draining Planetary Gear Oil

**NOTE**

Refer to your local/national regulations on how to dispose of used oil.

- Wipe off the magnetic drain plug with a clean rag and install it in the planetary.
- Reposition the plug to the 3 o'clock or 9 o'clock position then remove plug again.
- Slowly fill the planetary with 1 quart (0.95 liters) of gear oil until oil begins to overflow from the level/fill hole. Refer to [2.4 Recommended Fluids/Lubrications](#) for oil specifications.

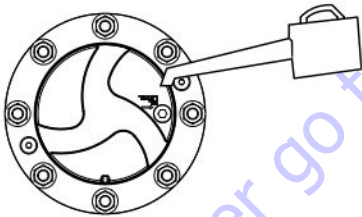

Figure 33 Filling Planetary Gear Oil

- Clean the level/fill plug and install it in the planetary.
- Repeat procedure for the remaining three planetary ends.

## 5.5-5 Change Engine Coolant

**WARNING**

Always shut off the engine and allow it to cool down before removing the radiator cap. Steam or fluid escaping from the radiator may cause severe injury. Remove cap slowly to relieve pressure. Avoid contact with steam or escaping fluid.

**NOTE**

Machines with an enclosed cab have a heater unit that needs to be flushed separately.

**NOTE**

Place the heat select switch in the full hot position if equipped.

- Open the radiator cap to ensure proper draining.

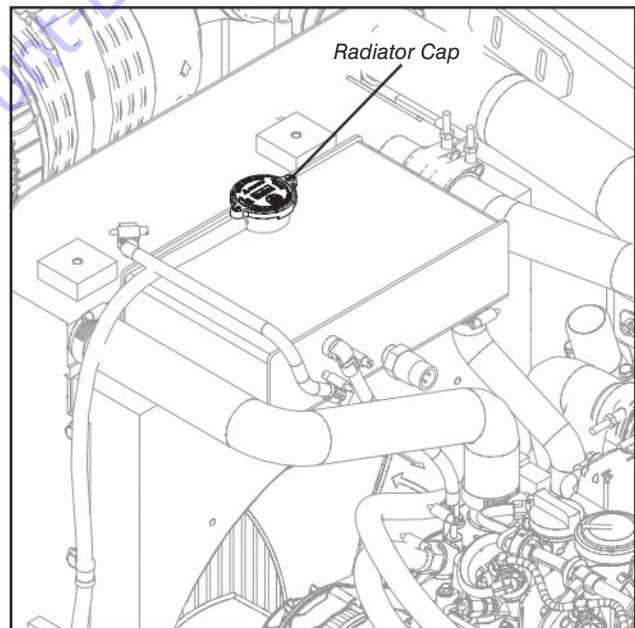

- Place a container capable of holding 5 gallons (17 liters) under the radiator drain plug.
- Open the drain plug and allow radiator and coolant bottle to drain.

**NOTE**

Refer to your local/national regulations on how to dispose of used coolant fluid.

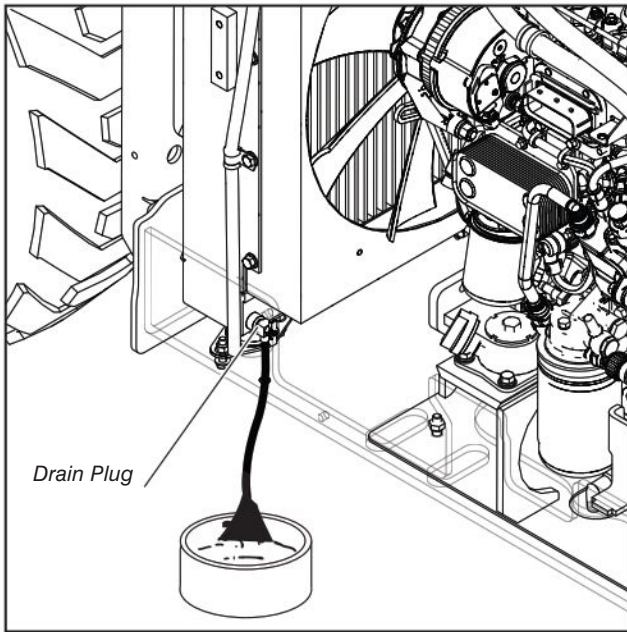

4. Close the drain plug.
5. Refill the radiator using a mixture of antifreeze and distilled water (2.4 Recommended Fluids/Lubrications). Refer to engine manufacturer's manual.

#### NOTE

If heater is equipped remove the plugged hose at the motorized heater valve and install the heater hose. Open manual heater valve.

6. Fill radiator completely through the radiator neck, until coolant is visible. See figure below.
7. Run the engine until the module display indicates 85° to 90° without radiator cap. Shut down the engine.
8. Check coolant level and coolant strength in the radiator. Adjust mixture as required. Refill until coolant is visible.
9. Tighten radiator cap, start the engine, and check for leaks.

## 5.6 Non-Routine Maintenance

### 5.6-1 Wear Pads Replacement Procedure

Wear pads are designed to protect the structural integrity of the boom sections. In addition, wear pads partially carry the weight of the boom sections and will wear out over time and based on daily operation. Ensure to check slide pads quarterly. Refer to 5.4-8 Check Boom Wear Pad Clearances for wear pads inspection procedure.

#### NOTE

The wear pads located at the rear-top and bottom-front of the boom sections wear faster than the other wear pads. The basic procedure for removing wear pads is the same regardless of their location in the boom assembly.

#### IMPORTANT

Pay attention to high-load slide pads (Front-Lower & Rear-Upper of boom) as most of the weight is exerted on them.

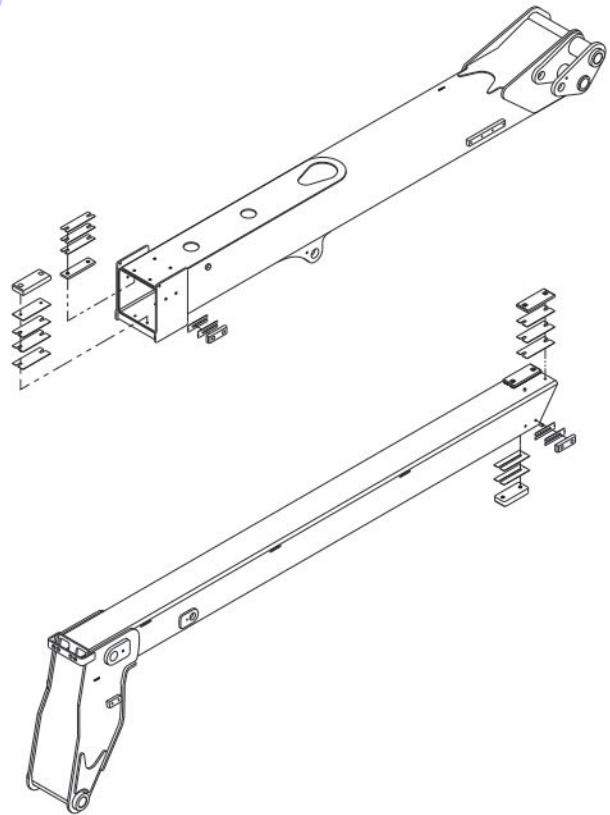

### Remove Wear Pads

1. Fully retract the boom.
2. Remove the rear cover.
3. Remove screw, wear pad, shims, and spacer from the boom. For ease of installation, keep all parts that were removed together as an assembly.

#### For the rear sides:

4. Before removing the screws from the wear pads, use a pry bar under the shims of the side wear pads. The bar prevents the shims from falling when the screws are removed.
5. Remove the screws, shims, and wear pads while holding the bar under the shim. For easier installation, keep all parts removed together as an assembly.

#### For the top boom:

6. The weight of the boom must be removed from the rear wear pads to allow removal. Use the boom control lever to lower the boom until the carriage is on the floor or surface. This action changes the load forces on the boom sections so that there is clearance between the wear pads and the outer boom.
7. Remove the screws, shims, and wear pads. For easier installation, keep all parts removed together as an assembly.

### Install Wear Pads



#### NOTE

To keep the boom section centered, make sure that the number of shims on the top wear pads are approximately equal to the number on the bottom wear pads. The number of shims on each side of the boom must also be approximately equal.



#### NOTE

Shims are 0.015, 0.030, and 0.060 inch thick. Add or subtract shims as required to obtain a clearance on the side between the middle and outer boom sections of 0.59" maximum. When the correct clearance is achieved, remove the screws and apply red thread locking compound to the threads of both the screws and wear pads.

1. Clean installation area to remove any residual grease. Ensure threads are free of grease, dirt.
2. With the carriage lowered to the floor, install the top wear pads.
3. Apply blue loctite and tighten the screws to 37 ft-lb.
4. Start the engine and raise the carriage from the floor.
5. Install the bottom wear pad assemblies.
6. Apply blue loctite red and tighten the screws to 37 ft-lb.

**For installation of the side wear pads:**

**NOTE**

Use a pry bar to hold the wear pads and shims in position.

7. Clean installation area to remove any residual grease. Ensure threads are free of grease, dirt.
8. Install the side wear pad assemblies.
9. Apply blue loctite and tighten the screws to 37 ft-lb. Ensure there is approximately an equal number of shims under each wear pad.
10. Lubricate all wear pads with MPG-EP2 grease.
11. Extend and retract the boom and check for smooth operation.
12. Install the rear cover.

**5.6-2 Display Fault Codes**

The display recognizes error messages that are sent from the engine via the data link. If a new error message is received, the display will begin to beep, and a flashing pop-up window will open with the latest error messages and details.

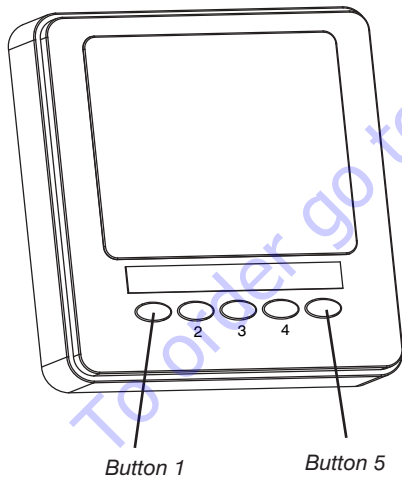

**Figure 34** Engine Data Display Module

If a new error message is received, the display will beep and a flashing popup window will open with the latest error messages and details.

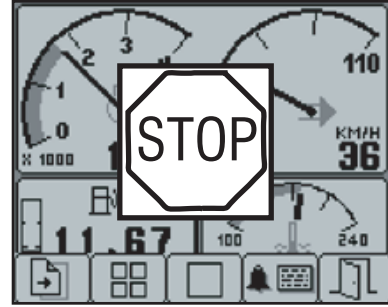

**Figure 35** Error Message Popup

The error list is displayed by pressing any button. The errors already viewed appear in black text on a grey background. New messages that have not been read yet appear as emphasized grey text on a black background. The alarm last received is automatically displayed the first time the error list is called up.

If the list is longer than the screen section, you can browse through the list using buttons 1 and 2.



**Figure 36** Error Message

The display cannot be quit until all alarms have been acknowledged by pressing button 3. The error list display can be activated at any time by pressing button 4.

The following pages contain information regarding the display Fault Codes; including the SPN code, FMI code, description of the fault code, as well as the recommended action to take.

J1939		Description	Recommended Action
SPN	FMI		
898	9	Timeout Error of CAN-Receive	Check CAN Bus wiring (Bus scheduling, polarity, short circuit, power interrupt), test protocol of receiver, check CAN functional range, check actuator.
520	9	Timeout Error of CAN-Receive	Check CAN Bus wiring (Bus scheduling, polarity, short circuit, power interrupt), test protocol of receiver, check CAN functional range, check actuator.
105	11	Charge air temperature sensor: the voltage of sensor measured by ECU is out of the target range	Check wiring, CAC-sensor not working, check sensor and if necessary replace it, check connection cable and if necessary repair or replace it.
523613	0, 1, or 2	Rail pressure: the fuel pressure in rail calculated by ECU is either below or above the target range which is dependant on the engine speed	Check for leakage. Check fuel level in tank and low pressure system. Check fuel-primary pressure. Check backflow pressure check sensor. Check pressure relief valve. Check metering unit. Check Injector function (metering unit, injector). If necessary replace components as required.
523165	3, 4, 5, or 12	Fuel metering unit: the ECU detects no load, or the current drain measured by ECU is above the target range, (Open, Short to B+, Short to B-)	Check wiring, if necessary check FCU, check fuel metering unit and if necessary replace it, check connection cable and if necessary repair or replace it
107	0, 3	Air filter differential pressure: the pressure difference of the intake air between the filter inlet and outlet calculated by ECU is above the target range	Check airfilter and if necessary clean or renew it, check wiring, check sensor and if necessary replace it, check connection cable and if necessary repair or replace it
1237	2	Override switch: the ECU receives a permanent signal	Check wiring, if sensor is not working, check switch and if necessary replace it, check connection cable and if necessary repair or replace it
523470	2, 7, 11, 12, or 14	Rail pressure: Pressure Relief Valve (PRV) error.	Check error memory for other additional errors and eliminate them first. Check working voltage and if necessary correct it, check PRV opening counter and if necessary replace it, check rail-pressure sensor and if necessary replace it, check FCU and if necessary replace it, check rail pressure relief valve and if
157	3, or 4	Rail pressure sensor: the voltage of sensor measured by ECU is out of the target range or shorted to B+ or B-.	Check wiring, check rail pressure sensor and if necessary replace it, check connection cable and if necessary repair or replace it
523350	4	Injector cylinder bank 1: the current drop measured by ECU is above the target range	Check wiring, check injectors and if necessary replace them, check connection cable and if necessary repair or replace it
523352	4	Injector cylinder bank 2: the current drop measured by ECU is above the target range	Check wiring, check injectors and if necessary replace them, check connection cable and if necessary repair or replace it
523354	12	Internal hardware monitoring: the ECU detects an error of its injector high current output	If error is not removable, change ECU
651	3, or 5	Injector cyl. 1: interruption of electrical connection or the current drop measured by ECU is above the target range	Check wiring and counter plugs, check injector and if necessary replace them, check connection cable and if necessary repair or replace it.
652	3, or 5	Injector cyl 3. : interruption of electrical connection or the current drop measured by ECU is above the target range	Check wiring, check injector and if necessary replace them, check connection cable and if necessary repair or replace it.
653	3, or 5	Injector cyl. 4: interruption of electrical connection or the current drop measured by ECU is above the target range	Check wiring, check injector and if necessary replace them, check connection cable and if necessary repair or replace it.
654	3, or 5	Injector cyl. 2: interruption of electrical connection or the current drop measured by ECU is above the target range	Check wiring, check injector and if necessary replace them, check connection cable and if necessary repair or replace it.
190	8, 12, or 14	Camshaft or Crankshaft speed sensor: out of range, signal disrupted, missing signal, or erratic signal	Check wiring of camshaft/crankshaft sensor, check camshaft/crankshaft sensor and if necessary replace it, check connection cable and if necessary repair or replace it
190	2	ECU measures a deviation between camshaft and crankshaft angle	Check increment wheel position, clean and adjust if necessary, check sensor position, reflash dataset
190	0, 11, or 14	Engine speed: the engine speed calculated by ECU is above the target range	check powertrain settings regarding overspeed
94	1, 3, or 4	Low fuel pressure sensor: the voltage of sensor measured by ECU is out of the target range	Check wiring, if sensor not working, check sensor and if necessary replace it, check connection cable and if necessary repair or replace it. Check low fuel pressure system (fuel feed pump, relay, fuse, wiring, sensor) and if necessary repair or replace it
102	1, 2, 3, or 4	Charge air pressure sensor: the measured voltage of sensor by ECU is out of the target range, either too high or too low.	Check wiring, if charge air pressure/temperature sensor is not working, check sensor and if necessary replace it, check connection cable and if necessary repair or replace it. Check waste gate system if necessary replace TC, check CAC if all channels are clean, check charge air piping if necessary clean or
100	3, 4	Oil pressure sensor: the voltage of sensor measured by ECU is out of the target range, either too high or too low.	Check sensor and if necessary replace it, check connection cable and if necessary repair or replace it
110	0, 1, 3, or 4	Coolant temperature sensor: the voltage of the sensor measured by ECU is out of the target range; either high or low.	Check wiring, sensor defect, check sensor and if necessary replace it, check connection cable and if necessary repair or replace it

307A-1

J1939		Description	Recommended Action
SPN	FMI		
91	3, 4, or 11	Sensor error accelerator pedal	Check wiring, check accelator pedal sensor and if necessary replace it, check connection cable and if necessary repair or replace it
97	3, 4, or 12	Fuel filter water level sensor: the voltage of sensor measured by ECU is out of the target range high or low.	Drain water out from pre-filter. Check wiring, if sensor is not working, check sensor and if necessary replace it, check connection cable and if necessary repair or replace it
100	0, or 1	Oil pressure is either above or below the target range	Check oil level, check engine for oil leakage, measure oil pressure external to evaluate sensor value, clean suction pipe inlet mesh in oilsump
110	0	Coolant temperature: the coolant temperature calculated by ECU is above the target range.	Clean radiator, check fan drive, check coolant level, check cooling system in general, check thermostat function.
105	0	Charge air temperature downstream calculated by ECU is above the target range	Check CAC system and clean it. Check fan functionality. Check cooling performance with temperature measurement.
111	1	Coolant level: the coolant level calculated by ECU is underneath the allowed minimum	Check coolant level, inspect cooling system for leakage and if necessary repair it, check sensor and wiring
523009	9, or 10	Rail pressure relief valve: is open more frequently, or longer than what the technical specification allows	Change rail pressure relief valve
639, 1231, or 1235	14	CAN bus 0, 1, or 2: the ECU is not allowed to send messages, because the status "BusOff" is detected	Check wiring of CAN bus and if necessary repair it, check connection cable and if necessary repair or replace it, check resistance in CAN lines (60 Ohm)
630	12	Access error: the ECU finds an error during the access to its EEPROM memory or works with an alternative value	ECU not programmed, EEPROM is defective, ECU is defective: reprogram ECU and if necessary replace it
1079, 1080, or 523601	13	Sensor supply voltage monitor error (ECU), Error in sensor voltage.	Check wiring of external components, check working voltage and if necessary correct it, check connection cable and if necessary repair or replace it, if error is not removable, change ECU
168	0, 1, 2, 3, or 4	Battery voltage: the voltage measured by ECU is out of the target range; either too high, too low, or erratic.	Check alternator, contact resistance, safety fuses, too high load in energy system, check battery and connections, check cables and if necessary clean, repair or replace component as required.
1109	2	Engine Shut Off demand has been ignored by the user	Warranty relevant, Additional error must be set
677	3, 4, 5, or 12	Starter relay; short circuit to B+ or B-, Open circuit, or powerstage over temperature	Check wiring and start relay and if necessary replace it, check connection cable and if necessary repair or replace it
523550	12	Start information to Starter (T50-switch) erratic, on too long.	Check wiring, if sensor not working, check start switch and if necessary replace it, check connection cable and if necessary repair or replace it
523612	3, 4, 12, or 14	ECU reported internal software error	Check error memory for other errors. Check wiring, check connected sensors and actuators. Re-flash the ECU. If error is still active replace ECU.
523698	11	Shut off request from supervisory monitoring function, Engine Shut Off due to supervisory function	Warranty relevant, Additional error must be set
5763	0, 1, 3, 4, 5, 6, 7, or 11	Actuator error EGR-Valve: signal out of range	Check wiring and repair or replace if necessary, check actuator/EGR and if necessary replace it
523982	0, 1	Powerstage diagnosis disabled; low or high battery voltage	Check wiring, check alternator, check cables and repair or replace if necessary
523906	3, 4, 5, or 12	ECU detects open load on the electric fuel feed pump output, too high temperature in powerstage of fuel pump circuit, or short to B+ or B-	Check wiring of the fuel feed pump circuit including relay, if necessary repair or replace wiring
524057	2	Electric fuel pump; fuel pressure build up error	Check low fuel pressure system (fuel feed pump, relay, fuse, wiring, sensor) and if necessary repair or replace it
524108	9	Missing CAN message of EGR throttle valve	Check CAN Bus wiring (Bus scheduling, polarity, short circuit, power interrupt), test protocol of receiver, check CAN functional range, check actuator
524109	9	Missing CAN message of EGR throttle valve	Check CAN Bus wiring (Bus scheduling, polarity, short circuit, power interrupt), test protocol of receiver, check CAN functional range, check actuator

307A-2

DRIVE CONTROLLER ERROR CODES					
DTC #	SPN	FMI	Description	Fault Conditions	Potential Cause
1	91	12	Accelerator Pedal Position 1 Failure	Pedal voltage greater than 1V and neutral switch reads 'neutral'	Wiring problem, faulty pedal
3	127	0	Transmission Pressure High	Engine running (>500 rpm) and either pressure transducer reading is higher than 7300 psi for 3 seconds	Faulty sensor or hydraulic system failure
4	127	2	Transmission Pressure Sensors Erratic, Intermittent, Or Incorrect	Both pressure sensors reading greater than 1v	Faulty sensor or short in wiring
5	127	7	Transmission Pressure Sensors Not Responding Properly	Engine is running (>500 rpm) and machine is in forward, Pump displacement > 0.9, And P port pressure > (N port pressure+270) psi or machine is in reverse, Pump displacement < -0.9, And N port pressure > (P port pressure + 270)	Pressure sensor connectors are swapped
6	127	18	Transmission Pressure Low	Park brake engaged and engine is running (>500 rpm) and either pressure transducer reading is lower than 200 psi for 5 seconds	Faulty sensor, charge relief valve stuck open
7	639	19	J1939 Network 1 (Engine Comm) Data Error	Loss of communication with engine ecu for greater than 500ms	Canbus wiring, ecu power
8	741	3	Transmission Forward Solenoid Voltage Above Normal	Measured voltage is greater than expected	Solenoid output shorted to power
9	741	5	Transmission Forward Solenoid Current Below Normal	Measured current is less than expected	Open circuit
10	741	6	Transmission Forward Solenoid Current Above Normal	Measured current is greater than expected	Wiring problem, faulty solenoid
11	751	12	Transmission Primary Shift Selector Failure	Forward and reverse signals are both 'on'	Wiring problem, faulty fnr switch
12	761	3	Transmission Forward Pressure Sensor Voltage Above Normal	Measured voltage is greater than expected	Wiring problem, faulty sensor
13	761	4	Transmission Forward Pressure Sensor Voltage Below Normal	Measured voltage is less than expected	Wiring problem, faulty sensor
14	763	3	Transmission Reverse Pressure Sensor Voltage Above Normal	Measured voltage is greater than expected	Wiring problem, faulty sensor
15	763	4	Transmission Reverse Pressure Sensor Voltage Below Normal	Measured voltage is less than expected	Wiring problem, faulty sensor
16	785	2	Transmission Hydraulic System Feedback Erratic, Intermittent, Or Incorrect	Pump swash traveling the wrong direction	Contamination, mechanical failure



DRIVE CONTROLLER ERROR CODES					
DTC #	SPN	FMI	Description	Fault Conditions	Potential Cause
17	785	3	Transmission Hydraulic System Feedback Voltage Above Normal	Pump feedback signal greater than maximum limit	Faulty sensor, out of range neutral calibration
18	785	13	Transmission Hydraulic System Feedback Voltage Out Of Range	Pump feedback voltage out of range	Wiring problem, faulty sensor
19	785	7	Transmission Hydraulic System Feedback Not Responding Properly	Pump swash is on the wrong side of neutral	Solenoid connectors swapped
20	785	11	Transmission Hydraulic System Out Of Calibration	Pump neutral calibrated out of range	Swash sensor out of adjustment, wiring problem
21	785	20	Transmission Neutral Drifting	Pump feedback neutral voltage drifts more than 50 mv from the calibrated neutral after releasing current from the coils for 3 consecutive times	Swash sensor out of adjustment check sensor shaft extension to ensure no binding condition
22	1709	3	Transmission Controller Power Relay Voltage Above Normal	Sensor supply voltage greater than expected	Wiring problem, short to power
23	1709	4	Transmission Controller Power Relay Voltage Below Normal	Sensor supply voltage less than expected	Wiring problem, over current on sensor supply
24	3958	3	Transmission High Range Actuator Voltage Above Normal	Measured voltage is greater than expected	Solenoid output shorted to power
25	3958	5	Transmission High Range Actuator Current Below Normal	Measured current is less than expected	Open circuit
26	3958	6	Transmission High Range Actuator Current Above Normal	Measured current is greater than expected	Wiring problem, faulty solenoid
27	4216	3	Transmission Reverse Solenoid Voltage Above Normal	Measured voltage is greater than expected	Solenoid output shorted to power
28	4216	5	Transmission Reverse Solenoid Current Below Normal	Measured current is less than expected	Open circuit
29	4216	6	Transmission High Range Actuator Current Above Normal	Measured current is greater than expected	Wiring problem, faulty solenoid
30	91	3	Accelerator Pedal Position 1 Voltage Above Normal	Measured voltage is greater than expected	Wiring problem, faulty sensor
31	91	4	Accelerator Pedal Position 1 Voltage Below Normal	Measured voltage is less than expected	Wiring problem, faulty sensor

### 5.6-3 Hydraulic Pressure Test Procedure

#### **IMPORTANT**

All checks and adjustments are to be made with the engine running at low idle, the transmission shifter in Neutral and the parking brake applied.

#### System Pressure

##### ▪ System Pressure Check:

1. Release residual pressure by moving the joystick several times in each direction.
2. Install a 5,000 psi gauge at port GP3 of Main Manifold.

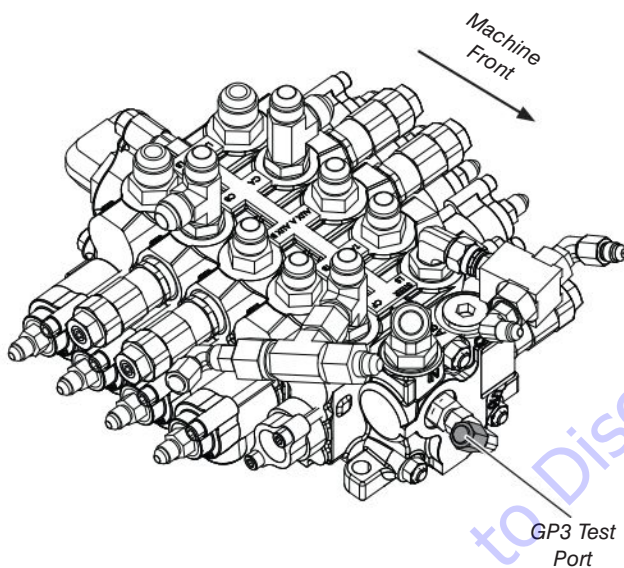

3. With engine running at low idle, dead-head the boom retract function. Indicated system pressure should be 3900 psi.
4. If reading is different than what is mentioned above, adjustment is required.

##### ▪ System Pressure Adjustment:

1. Loosen the lock nut on the pressure reducing valve at port RV1 on the Main Control Valve.

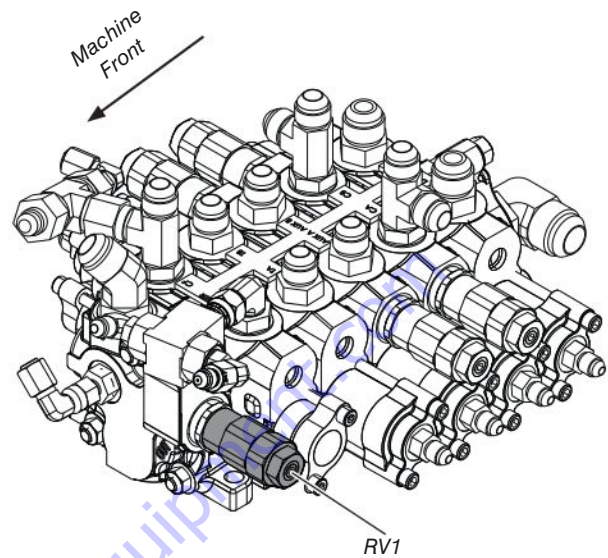

2. With engine running at low idle, turn the adjustment screw clockwise (CW) to increase the pressure reading and counter-clockwise (CCW) to reduce the pressure reading until desired reading is achieved.
3. Tighten the lock nut on the valve RV1 and re-check the reading to ensure that the correct pressure is maintained.

## Steering Pressure

### Steering Pressure Check:

1. Release residual pressure by moving the joystick several times in each direction
2. Install a 5,000 psi gauge into port GP2 at the front of the main manifold as shown in figure below.

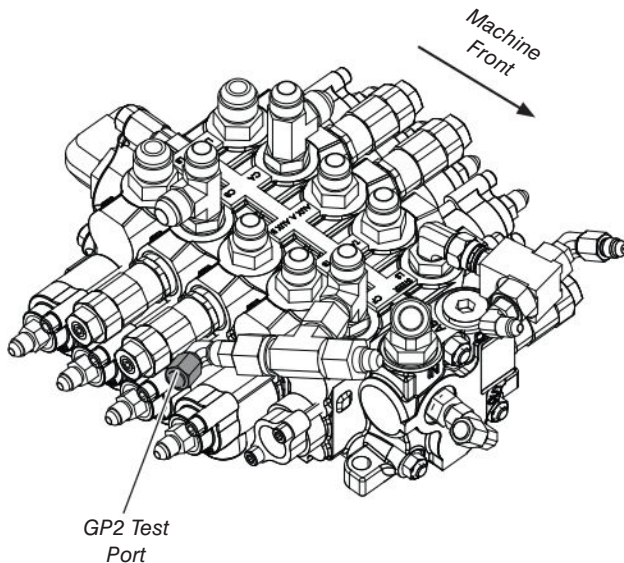

3. With engine running at low idle and steering dead-headed in either direction, read the pressure indicated on the gauge. The correct pressure should be 2,000 psi.
4. If reading is other than 2,000 psi, adjust the orbit motor.

### Steering Pressure Adjustment:

1. Remove the plug on the top face of the orbital motor.

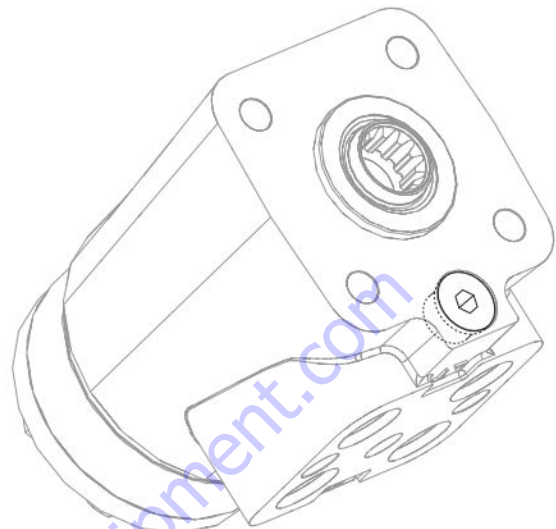

2. With engine running at low idle, turn the adjustment screw clockwise (CW) to increase the pressure reading and counter-clockwise (CCW) to reduce the pressure reading until desired reading is achieved.
3. Check the reading to ensure that the correct pressure is maintained.

### Service Brake Pressure

#### ▪ Service Brake Pressure Check:

1. Release residual pressure by moving the joystick several times in each direction.
2. Remove plug and install a 1,500 psi gauge into the GP2 port on the main manifold.

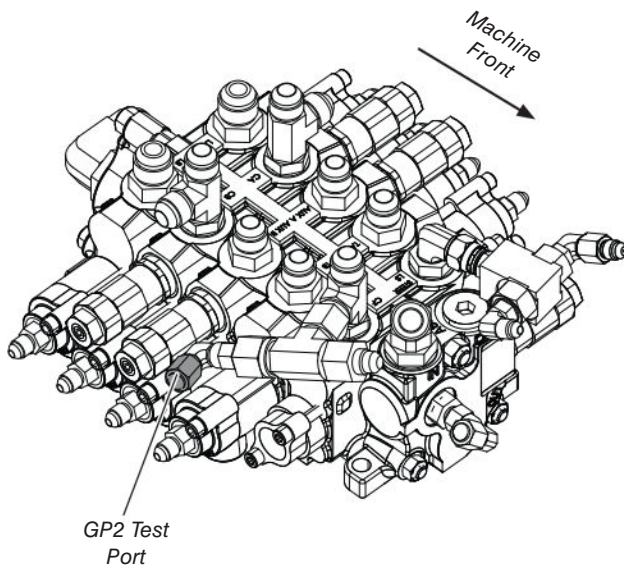

3. With engine running at low idle, depress brake pedal fully. Pressure should increase proportionally to 1,000 psi MAX.
4. If maximum pressure is less than 1,000 psi, brake valve must be replaced.

#### **NOTE**

The pressure setting value is the nominal maximum value.

### **IMPORTANT**

There is no adjustment. Replace the brake valve at the service brake pedal.

### Pilot Pressure

#### ▪ Pilot Pressure Check:

1. Release residual pressure by moving the joystick several times in each direction.
2. Install a 1,000 psi gauge into the fitting at port SP1 (GP1) of the hydraulic function manifold.
3. With engine running at low idle and NO hydraulic function engaged, pressure should be  $350 \pm 25$  psi.

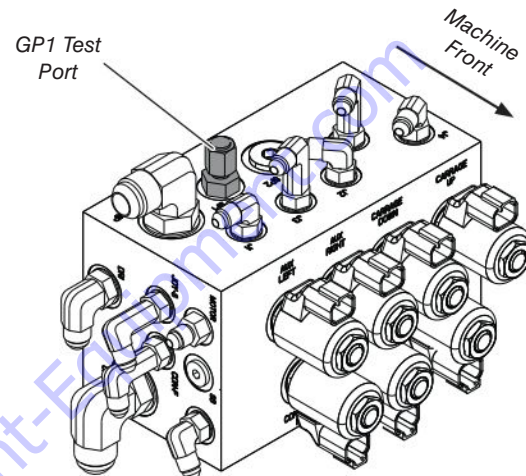

#### ▪ Pilot Pressure Adjustment:

1. Locate RV6 on the drive pump and remove the plug to access the spring and pop it. Hold the relief main body to prevent it from loosening.
2. Inspect the seat area of the poppit for any unusual wear, damage, or debris. If damaged then the complete valve must be replaced

**Fork Tilt Pressure**

▪ **Fork Tilt Pressure Check:**

1. Install a 5,000 psi gauge at port GP3 of Main Manifold.

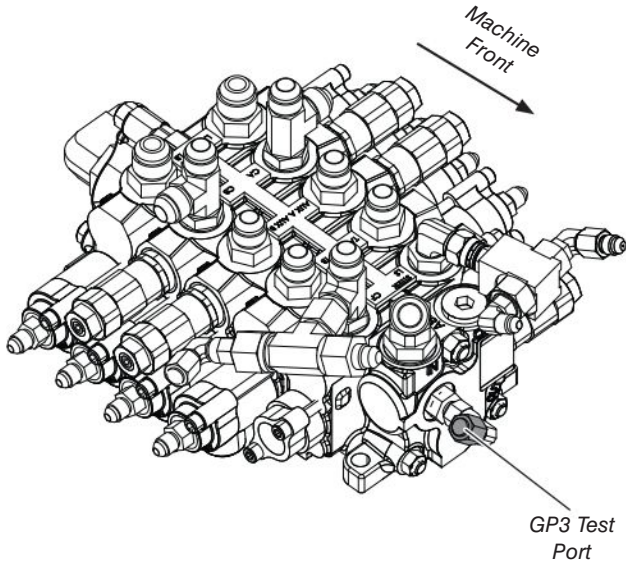

2. With engine running at low idle, dead-head in both directions the fork tilt function. Indicated system pressure should be 3,500 psi for both directions.
3. If reading is different than 3,500 psi, adjustment is required.

▪ **Fork Tilt Pressure Adjustment:**

▪ **Fork Tilt Cylinder Extend**

1. Loosen the lock nut on the pressure reducing valve at port RV5 on the Main Manifold.
2. With engine running at low idle, turn the adjustment screw clockwise (CW) to increase the pressure reading and counter-clockwise (CCW) to reduce the pressure reading until desired reading is achieved.
3. Tighten the lock nut on the valve RV5 and re-check the reading to ensure that the correct pressure is maintained.

▪ **Fork Tilt Cylinder Retract**

1. Loosen the lock nut on the pressure reducing valve at port RV4 on the Main Manifold.
2. With engine running at low idle, turn the adjustment screw clockwise (CW) to increase the pressure reading and counter-clockwise (CCW) to reduce the pressure reading until desired reading is achieved.
3. Tighten the lock nut on the valve RV4 and re-check the reading to ensure that the correct pressure is maintained.

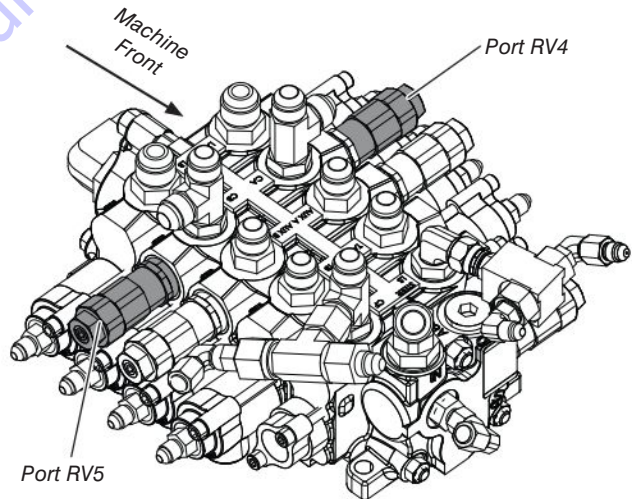

### Auxiliary Hydraulics Pressure

#### ▪ Auxiliary Hydraulics Pressure Check:

1. Install a 5,000 psi gauge at port GP3 of Main Manifold.

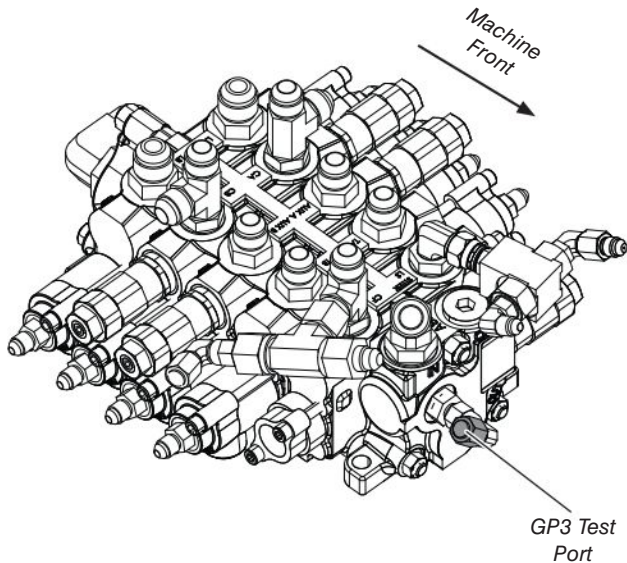

**Figure 37** System Pressure Adjustment

2. With engine running at low idle, dead-head in both directions the auxiliary hydraulics functions. Indicated system pressure should be 3000 psi for both directions.
3. If reading is different than 3,000 psi, adjustment is required.

#### ▪ Fork Tilt Pressure Adjustment:

##### ▪ Auxiliary Hydraulics Port B

1. Loosen the lock nut on the pressure reducing valve at port RV3 on the Main Manifold.
2. With engine running at low idle, turn the adjustment screw clockwise (CW) to increase the pressure reading and counter-clockwise (CCW) to reduce the pressure reading until desired reading is achieved.
3. Tighten the lock nut on the valve RV3 and re-check the reading to ensure that the correct pressure is maintained.

##### ▪ Auxiliary Hydraulics Port A

1. Loosen the lock nut on the pressure reducing valve at port RV2 on the Main Manifold.
2. With engine running at low idle, turn the adjustment screw clockwise (CW) to increase the pressure reading and counter-clockwise (CCW) to reduce the pressure reading until desired reading is achieved.
3. Tighten the lock nut on the valve RV2 and re-check the reading to ensure that the correct pressure is maintained.

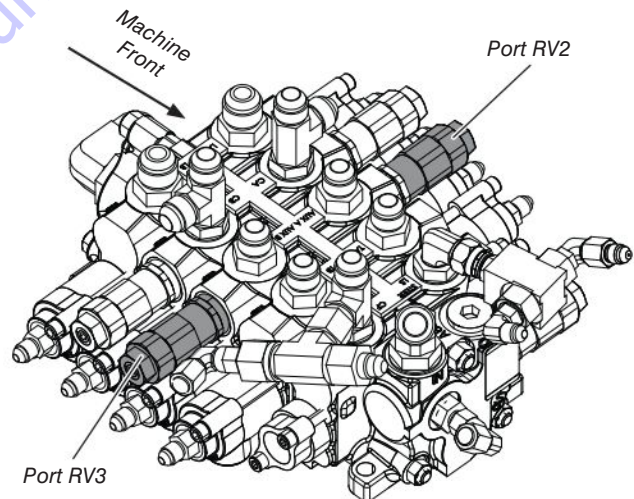

## 5.6-4 Bleeding Hydraulic Circuits



### NOTE

*Whenever a hydraulic system is opened up, it is necessary to bleed or purge the air from the circuit that was opened.*

### Bleed Carriage Tilt Circuit

1. Tilt carriage to full forward position.
2. Raise boom fully while extending boom to keep carriage ahead of the front tires.
3. Tilt carriage to full backward position.
4. Lower and retract boom fully.
5. Tilt carriage forward as much as possible and raise boom to facilitate tilting carriage fully forward.
6. Repeat steps 1 through 5, five times
7. Check for air in the system by leveling forks and raising and lowering the boom several times while watching the forks to see if they stay level. If the forks do not stay level repeat above steps and re-check.

### Bleed Boom Extend/Retract Circuit

- Fully extend and retract boom several times with boom level.

### Bleed Boom Raise/Lower Circuit

- Fully raise and lower the boom several times. Ensure carriage remains ahead of the front tires.

### Bleed Frame Level Circuit

- Tilt telehandler fully side to side several times with boom in a low position.

### Bleed Auxiliary/Optional Circuits

- Operate function fully in both directions several times.

### Bleed Outriggers Circuit

- Fully lower and raise outriggers several times.

### Bleed Brake Circuit

1. With engine running depress and hold brake pedal. The hydraulic pump will constantly supply fluid; there is no need to pump the brake pedal.
2. Locate bleeder fittings on top of brake calipers at each wheel.
3. Starting with the fitting furthest from the pedal and working your way to the closest, slightly open each bleeder and close when hydraulic oil comes out clear.
4. Slowly loosen hose fitting at pressure switch shuttle valve on left frame rail. Tighten when fluid comes out clear.
4. Upper and Lower Guide Brackets
5. Cable Tracks
6. Carrier Assembly
7. Side Access Holes

### 5.6-5 Brake Inspection

1. Remove the oil level plug from one of the braking axle arms, as shown below.

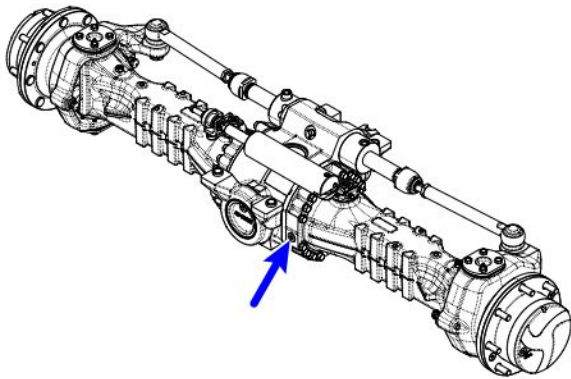

2. Insert a 4.5 mm feeler gauge into the drain port.

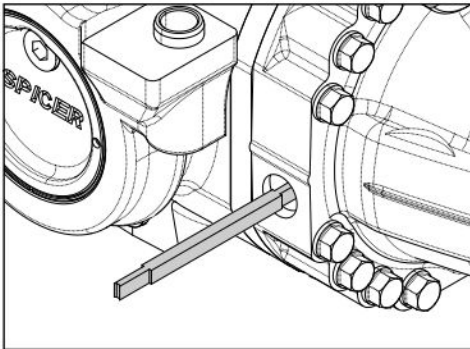

3. Use the gauge to check the gap between the disks (A). The minimum distance allowed is 4.5 mm. Reinstall the oil level plug.

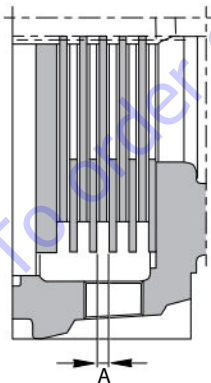

4. Repeat the inspection on the other axle arm. If the gap is smaller than 4.5 mm between the disks of either arm (i.e. the gauge doesn't fit), the brake disks must be replaced on both arms.



**TO PURCHASE THIS PRODUCT PLEASE CONTACT US**



**Equipment Financing and  
Extended Warranties Available**



**Discount-Equipment.com is your online resource for  
commercial and industrial quality parts and equipment sales.**

**561-964-4949**

**visit us on line @ [www.discount-equipment.com](http://www.discount-equipment.com)**

Select an option below to find your Equipment

**Search by Manufacturer**

**Search by Product Type**

**Request a Quote**

We sell worldwide for the brands: Genie, Terex, JLG, MultiQuip, Mikasa, Essick, Whiteman, Mayco, Toro Stone, Diamond Products, Generac Magnum, Airman, Haulotte, Barreto, Power Blanket, Nifty Lift, Atlas Copco, Chicago Pneumatic, Allmand, Miller Curber, Skyjack, Lull, Skytrak, Tsurumi, Husquvarna Target, Stow, Wacker, Sakai, Mi-T-M, Sullair, Basic, Dynapac, MBW, Weber, Bartell, Bennar Newman, Haulotte, Ditch Runner, Menegotti, Morrison, Contec, Buddy, Crown, Edco, Wyco, Bomag, Laymor, EZ Trench, Bil-Jax, F.S. Curtis, Gehl Pavers, Heli, Honda, ICS/PowerGrit, IHI, Partner, Imer, Clipper, MMD, Koshin, Rice, CH&E, General Equipment, Amida, Coleman, NAC, Gradall, Square Shooter, Kent, Stanley, Tamco, Toku, Hatz, Kohler, Robin, Wisconsin, Northrock, Oztec, Toker TK, Rol-Air, APT, Wylie, Ingersoll Rand / Doosan, Innovatech, Con X, Ammann, Mecalac, Makinex, Smith Surface Prep, Small Line, Wanco, Yanmar



[www.Discount-Equipment.com](http://www.Discount-Equipment.com)

To order go to [Discount-Equipment.com](http://Discount-Equipment.com)

