



www.Discount-Equipment.com

SKYJACK

OPERATION MANUAL

SJ40 T+, SJ45 T+

TELESCOPIC BOOMS

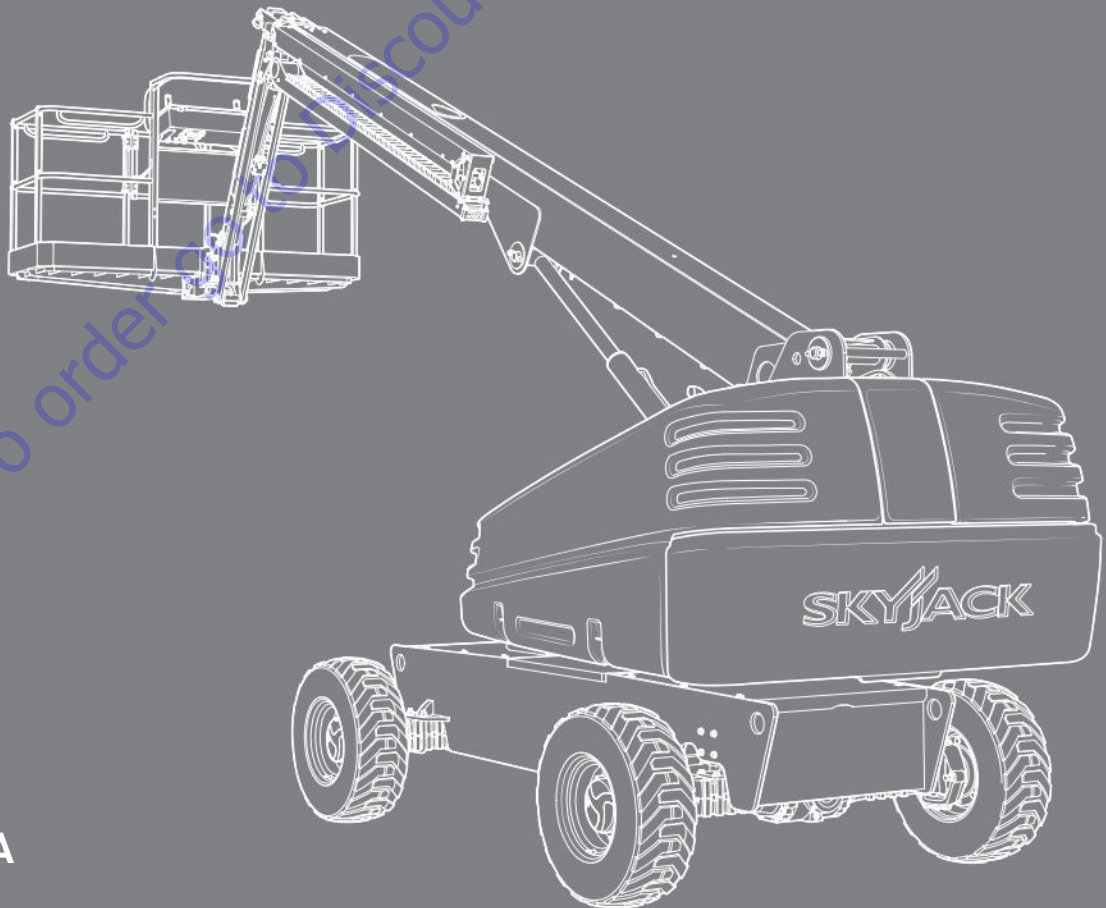

238261AAA
February 2021
ANSI/CSA

TO PURCHASE THIS PRODUCT PLEASE CONTACT US



**Equipment Financing and
Extended Warranties Available**



**Discount-Equipment.com is your online resource for
commercial and industrial quality parts and equipment sales.**

561-964-4949

visit us on line @ www.discount-equipment.com

Select an option below to find your Equipment

Search by Manufacturer

Search by Product Type

Request a Quote

We sell worldwide for the brands: Genie, Terex, JLG, MultiQuip, Mikasa, Essick, Whiteman, Mayco, Toro Stone, Diamond Products, Generac Magnum, Airman, Haulotte, Barreto, Power Blanket, Nifty Lift, Atlas Copco, Chicago Pneumatic, Allmand, Miller Curber, Skyjack, Lull, Skytrak, Tsurumi, Husquvarna Target, Stow, Wacker, Sakai, Mi-T-M, Sullair, Basic, Dynapac, MBW, Weber, Bartell, Bennar Newman, Haulotte, Ditch Runner, Menegotti, Morrison, Contec, Buddy, Crown, Edco, Wyco, Bomag, Laymor, EZ Trench, Bil-Jax, F.S. Curtis, Gehl Pavers, Heli, Honda, ICS/PowerGrit, IHI, Partner, Imer, Clipper, MMD, Koshin, Rice, CH&E, General Equipment, Amida, Coleman, NAC, Gradall, Square Shooter, Kent, Stanley, Tamco, Toku, Hatz, Kohler, Robin, Wisconsin, Northrock, Oztec, Toker TK, Rol-Air, APT, Wylie, Ingersoll Rand / Doosan, Innovatech, Con X, Ammann, Mecalac, Makinex, Smith Surface Prep, Small Line, Wanco, Yanmar

This manual is for MEWPs with serial numbers:

SJ40 T+: A400 000 263 & above

SJ45 T+: A400 000 263 & above

To order go to Discount-Equipment.com

The original instructions are in English.

THIS SAFETY ALERT SYMBOL MEANS ATTENTION!



BE ALERT! YOUR SAFETY IS INVOLVED.

The Safety Alert Symbol identifies important safety messages on MEWPs, safety signs in manuals or elsewhere. When you see this symbol, be alert to the possibility of personal injury or death. Follow the instructions in the safety message.

DANGER

DANGER indicates an imminently hazardous situation which, if not avoided, will result in death or serious injury.

WARNING

WARNING indicates a potentially hazardous situation which, if not avoided, could result in death or serious injury.

CAUTION

CAUTION indicates a potentially hazardous situation which, if not avoided, may result in minor or moderate injury. It may also be used to alert against unsafe practices.

IMPORTANT

IMPORTANT indicates a procedure essential for safe operation and which, if not followed, may result in a malfunction or damage to the MEWP.

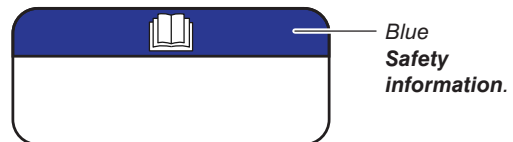
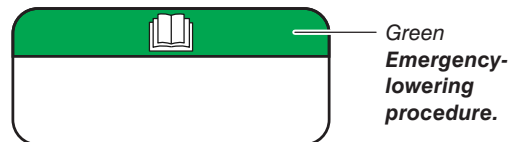
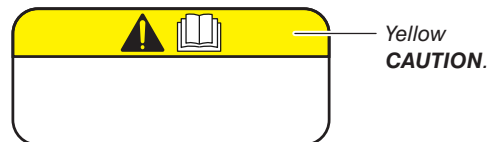
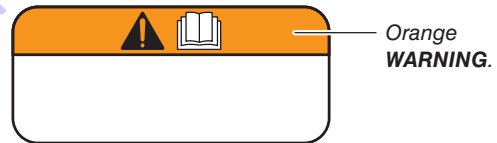
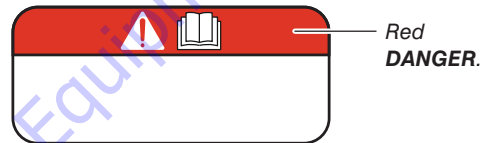

Table of Contents

Section 1 – About this Mobile Elevating Work Platform (MEWP)	9
1.1 Read and heed.	9
1.1-1 <i>Mobile Elevating Work Platform (MEWP) definition</i>	9
1.1-2 <i>Purpose of equipment</i>	9
1.1-3 <i>Use of equipment</i>	9
1.1-4 <i>Operation manual</i>	9
1.1-5 <i>Operator</i>	9
1.1-6 <i>Service policy and warranty</i>	9
1.1-7 <i>Ownership of MEWP</i>	9
1.1-8 <i>Optional equipment</i>	9
1.1-9 <i>Scope of this manual</i>	10
1.2 Primary assemblies	11
1.3 Serial number nameplate	13
1.4 Maintenance responsibility	14
1.4-1 <i>Operator</i>	14
1.4-2 <i>Maintenance and inspection schedule</i>	14
1.4-3 <i>Owner</i>	14
Section 2 – General Safety Precautions	15
2.1 Electrocuting hazards	15
2.1-1 <i>Minimum distance from electrical conductors</i>	15
2.2 Safety instructions	16
2.3 Fall-protection	19
2.4 Worksite inspection	19
Section 3 – Familiarization	21
3.1 Overview of the MEWP	22
3.2 Manual storage box	23
3.3 Control functions	23
3.3-1 <i>Main power disconnect switch</i>	23
3.3-2 <i>Footswitch</i>	23
3.3-3 <i>Engine display module</i>	23
3.3-4 <i>Positive air shut-off (optional equipment)</i>	23
3.3-5 <i>Base control console</i>	24
3.3-6 <i>Platform control console</i>	26
3.4 Features and devices	29
3.4-1 <i>Lowered travel position and elevated travel position</i>	29
3.4-2 <i>Drive speed</i>	30

3.4-3	<i>Drive direction</i>	30
3.4-4	<i>Tilt switch</i>	30
3.4-5	<i>Function restrictions when the MEWP is tilted</i>	30
3.4-6	<i>Platform load sensing system</i>	30
3.4-7	<i>Overload status</i>	31
3.4-8	<i>Brake-release system</i>	32
3.4-9	<i>Secondary guarding electrical (SGE)</i>	32
3.4-10	<i>Drive-bypass valve</i>	33
3.4-11	<i>AC power socket on the platform</i>	33
3.4-12	<i>Motion alarm</i>	33
3.4-13	<i>Differential lock switch</i>	33
3.4-14	<i>Turret transportation lock</i>	33
3.5	Optional equipment	34
3.5-1	<i>AC power socket on the platform</i>	34
3.5-2	<i>Flashing amber light</i>	34
3.5-3	<i>Welder</i>	34
3.5-4	<i>Cold or arctic weather package</i>	35
3.5-5	<i>Tool Tray</i>	35
3.5-6	<i>Glazier</i>	35
3.5-7	<i>Pipe Rack</i>	36
3.5-8	<i>Elevate™ telematics - access control unit</i>	36
Section 4 – Inspections Before Operation		39
4.1	Operator’s responsibility	39
4.2	Visual and daily maintenance inspections	40
4.2-1	<i>Labels</i>	40
4.2-2	<i>Electrical</i>	40
4.2-3	<i>Limit switches</i>	40
4.2-4	<i>Hydraulic</i>	40
4.2-5	<i>Engine compartment</i>	41
4.2-6	<i>Control compartment</i>	43
4.2-7	<i>Base</i>	45
4.2-8	<i>Platform assembly</i>	47
4.2-9	<i>Boom assembly</i>	48
4.2-10	<i>Optional equipment</i>	49
4.3	Function tests	50
4.3-1	<i>Do a test of the main power disconnect switch</i>	50
4.3-2	<i>Do a test of the base keyswitch and the emergency-stop button and light</i>	50
4.3-3	<i>Do a test of the start/function enable/emergency power switch and all the boom and platform functions</i>	51
4.3-4	<i>Do a test of the platform self-leveling</i>	51
4.3-5	<i>Do a test of the platform capacity zone indicator lights</i>	52
4.3-6	<i>Do a test of the emergency power unit</i>	52

4.3-7	Do a test of the off/base/platform switch	53
4.3-8	Do a test of the positive air shut-off switch (optional equipment)	54
4.3-9	Do a test of the emergency-stop button and emergency-stop light on the platform	55
4.3-10	Do a test of the load sensing module self-check	55
4.3-11	Do a test of the footswitch and all the boom and platform functions	56
4.3-12	Do a test of the platform capacity zone indicator lights	56
4.3-13	Do a test of the secondary guarding electrical (SGE)	57
4.3-14	Do a test of the engine start/on/off switch	58
4.3-15	Do a test of the emergency power unit.	58
4.3-16	Do a test of the manual platform-leveling	59
4.3-17	Do a test of the steer function.	59
4.3-18	Do a test of the drive function.	59
4.3-19	Do a test of the brakes	59
4.3-20	Do a test of the horn	59
4.3-21	Do a test of the elevated travel speed	60
4.3-22	Do a test of the differential lock switch.	60
4.3-23	Do a test of the oscillating cylinders.	61
4.4	Operator's checklist	62
Section 5 – Operation.		65
5.1	Energize the base control console	65
5.2	Rotate the platform with the base control console	66
5.3	Rotate the turret with the base control console	66
5.4	Move the jib up and down with the base control console.	66
5.5	Raise or lower the main boom with the base control console	66
5.6	Extend or retract the boom with the base control console	66
5.7	Make the platform level with the base control console.	67
5.8	Operate with the emergency power switch at the base control console	67
5.9	Energize the platform control console	67
5.10	Drive forward or rearward	68
5.11	Steer.	68
5.12	Move the jib up and down with the platform control console.	68
5.13	Extend or retract the boom with the platform control console	68
5.14	Make the platform level with the platform control console.	68
5.15	Rotate the platform with the platform control console	68
5.16	Raise or lower the main boom with the platform control console	69
5.17	Operate the horn	69
5.18	Rotate the turret with the platform control console.	69
5.19	Operate with the emergency power switch at the platform control console	69
5.20	Engage or disengage the differential lock switch	69
5.21	MEWP shutdown	70
5.22	Generator (optional equipment)	70
5.23	Glazier Tray (optional equipment)	70

5.24	Pipe Rack (optional equipment)	70
5.25	Cold or arctic weather package (optional equipment)	71
Section 6 – Additional Procedures		73
6.1	Use the emergency-lowering function	73
6.1-1	At the base control console:	73
6.1-2	At the platform control console:	73
6.2	Chassis tilt recovery	74
6.2-1	Platform uphill	74
6.2-2	Platform downhill	74
6.3	Release the brakes manually	75
6.4	Winch and tow the MEWP	76
6.5	Refuel	77
6.5-1	Refuel the MEWP with diesel	77
6.6	Move the MEWP for transport	78
6.6-1	Lock the turret	78
6.6-2	Hoist the MEWP	79
6.6-3	Tie down the MEWP	80
Section 7 – Technical Diagrams and Specifications		81
7.1	Technical diagrams	82
7.1-1	Reach diagram - SJ40 T+	82
7.1-2	Reach diagram - SJ45 T+	82
7.1-3	Dimensions - SJ40 T+	83
7.1-4	Dimensions - SJ45 T+	85
7.2	Standard and optional equipment	87
7.3	Owner's annual inspection record	88
7.4	Specifications	89
7.5	Environment	90
7.6	Tire/wheel specifications	90
7.7	Maximum platform capacities (evenly distributed)	91
7.8	Floor loading pressure	92
Section 8 – Labels		93
8.1	Engine side	94
8.2	Engine compartment	97
8.3	Front	99
8.4	Control side	100
8.5	Control compartment	105
8.6	Rear	109
8.7	Platform	112
8.8	Platform railings	114
8.9	Platform control console	115
Section 9 – Unique Skyjack Features		119

Section 1 – About this Mobile Elevating Work Platform (MEWP)

1.1 Read and heed

Skyjack is continuously improving and expanding product features on its equipment; therefore, specifications and dimensions are subject to change without notice.

1.1-1 Mobile Elevating Work Platform (MEWP) definition

A mobile machine intended for moving persons, tools, and material to working positions, consisting of a work platform with controls, an extending structure and a chassis.

1.1-2 Purpose of equipment

The Skyjack Articulating Booms Lifts are designed to move personnel, tools, and materials to working positions.

1.1-3 Use of equipment

The MEWP is a highly maneuverable, mobile work station. Work platform elevation and elevated driving must only be done on a firm, level surface.

1.1-4 Operation manual

The operation manual is an important part of the MEWP. It is important to always keep a copy of this manual in the weather-resistant manual storage box of the MEWP. The manual must be in good condition.

1.1-5 Operator

The operator must read and completely understand this operation manual, the safety panel label located on the platform, the limitations, operating procedures, operator's responsibility for maintenance and all other warnings and instructions in this manual and on the MEWP.

Before you operate the MEWP, make sure you read and completely understand this information:

1. The full contents of the operation manual, including the MEWP limitations and the responsibilities of the operator for the operation, applicable maintenance and safety instructions.
2. The safety panel label on the platform, the labels on the MEWP and the attachments.

Compare the labels on the MEWP with the labels in this manual. Immediately replace any labels that are damaged or missing.

Only trained and authorized personnel shall be permitted to operate a MEWP.

The operator must be familiar with the employer's work rules and related government regulations.

1.1-6 Service policy and warranty

Skyjack warrants each new product to be free of defective parts and workmanship for the first 2 years or 3000 hours, whichever occurs first. Any defective part will be replaced or repaired by your local Skyjack dealer at no charge for parts or labor. In addition, all products have a 5 year structural warranty. Contact the Skyjack Service Department for warranty statement extensions or exclusions.

1.1-7 Ownership of MEWP

Notify Skyjack of MEWP ownership. If you sell or transfer the ownership of a MEWP, promptly notify Skyjack of the new owner's contact information.

Skyjack needs this information to inform the owner of any updates or additional activities that are necessary to keep the machine in proper working condition.

1.1-8 Optional equipment

This MEWP is designed to accept a variety of optional accessories. Refer to [Section 7.2](#) for a list of the optional accessories. Operating instructions for these options are located in [Section 5](#) of this manual.

For components or systems that are not standard, speak to the Skyjack Service Department. Give the model and serial number for each applicable MEWP.

1.1-9 Scope of this manual

1. This manual applies to the ANSI/SAIA and CSA versions of the Telescopic Boom Lift series. For a list of applicable models, refer to [Section 7.2](#).
 - Equipment identified with ANSI meets the ANSI/SAIA A92.20-2018 standard.
 - Equipment identified with CSA meets the CSA B354.6:2017 standard.

To order go to Discount-Equipment.com

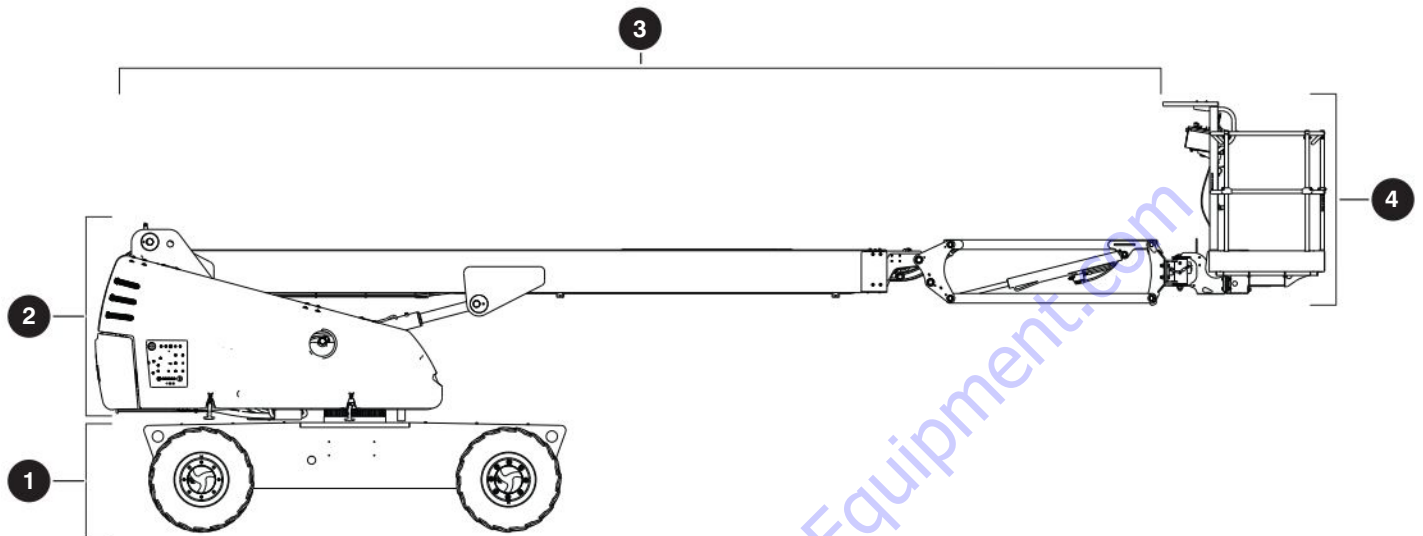

1.2 Primary assemblies

The MEWP has these primary assemblies:

1. Base
2. Turret
3. Boom
4. Platform.

1 Base: The base has these parts:

- A chassis
- A steerable front axle
- A rigid rear axle.

2 Turret: The turret turns 360 degrees continuously. It has these parts.

- A compartment on the right side of the turret which has these parts.
 - Engine
 - Hydraulic pumps
 - Battery
 - Swing drive.

- A compartment on the left side of the turret which has these parts.

- Base control console
- Emergency-lowering system at the base control console.
- Hydraulic manifolds
- Function valves
- Hydraulic tank
- Fuel tank.

3 Boom: The boom assembly has these parts.

- A main boom
- A mid boom
- A fly boom
- A jib boom

4 Platform: The platform has these parts.

- Slip-resistant deck surface.
- Hinged tubular guardrails, with mid-rails, and toe-boards.
- Tri-entry drop bars or an optional swing gate
- AC power socket
- Platform control console.

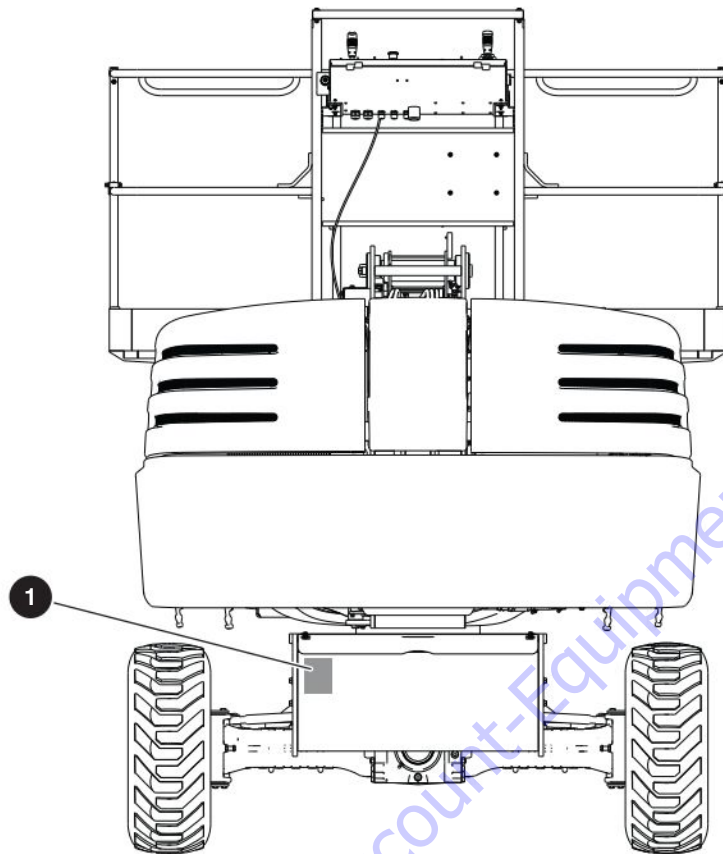

1.3 Serial number nameplate

The **serial number nameplate 1** is located at the front side of the MEWP. It contains this information:

- Model number
- Type
- Group
- Serial number
- High-capacity zone and low-capacity zone
- Capacity and maximum number of persons
- Maximum work platform height
- Maximum wind speed
- Maximum manual force
- MEWP weight
- Voltage
- Maximum incline
- System pressure
- Model year
- Year of manufacture

1.4 Maintenance responsibility

1.4-1 Operator

Before the beginning of each shift, do all the daily inspections and function tests. Refer to [Section 4](#).

1.4-2 Maintenance and inspection schedule

Refer to the service manual for frequent, periodic, and annual inspections.

The actual operating environment of the MEWP may affect the maintenance schedule.

IMPORTANT

Only use original or manufacturer-approved parts and components for the MEWP.

NOTE

Refer to the Skyjack web site (www.skyjack.com) for machine registration and the latest service bulletins before you do frequent/periodic or annual inspections.

1.4-3 Owner

The owner is responsible for maintenance inspections and repairs. Refer to the service manual for the recommended maintenance and inspection areas and intervals. Keep a record of the annual inspection on the label on the cowling of the control compartment. Refer to [Section 7.3](#) in this manual.

WARNING

Only trained and qualified/competent personnel, who understand the mechanical procedures, may do maintenance on the MEWP. The use of a MEWP that is not properly maintained or in the correct working condition could result in death or serious injury.

Section 2 – General Safety Precautions

WARNING

Failure to obey the instructions and precautions in this manual could result in MEWP damage, property damage, personal injury, or death.

It is mandatory that you use this MEWP correctly. Read this manual and make sure you fully understand it before you operate the MEWP.

Use personal protective equipment (PPE) when you do work on or near machinery to protect your eyes, ears, hands, feet, and body.

Any modifications to the MEWP must have written permission from Skyjack.

WARNING

Do not operate the MEWP if:

- It does not operate correctly
- It is damaged or shows worn or missing parts
- The safety devices are tampered with or disabled
- It is locked and tagged for servicing or repair
- It was modified without permission from Skyjack and the MEWP owner.

If you do not obey, there is a risk of death or serious injury.

2.1 Electrocuting hazards

The MEWP is not electrically insulated and does not provide protection from contact with or proximity to energized electrical conductors. Follow [Section 2.1-1](#) for the minimum distance to keep between all parts of the MEWP, occupants, or tools, and the electrical conductors. Consider MEWP movement and electrical line sway in minimum distance calculation.

If you need to work nearer than 3 m (10 ft), stop and apply control measures as determined by a qualified person with respect to electrical transmission and distribution.

Obey all the national, state/provincial/territorial and local safety rules.

2.1-1 Minimum distance from electrical conductors

Voltage Range	Minimum Distance from Electrical Conductors
≤ 50 KVA	3 m (10 ft)
> 50 KVA, or if not known	STOP and apply control measures as determined by a qualified person with respect to electrical transmission and distribution.

DANGER

Electrocution hazard. Keep all parts of the MEWP, occupants, or tools a safe distance away from power lines, electrical power sources, or energized sources. If you do not obey, there is a risk of death or serious injury.



Keep a minimum safe distance from sources of high-voltage power.



DO NOT operate the MEWP during lightning or storms.

CAUTION

DO NOT use the MEWP as a ground for welding. If you do not obey, there is a risk of minor or moderate injury, or malfunction or damage to the MEWP.

2.2 Safety instructions

WARNING

DO NOT operate this MEWP without proper authorization and training. Failure to avoid this hazard could result in death or serious injury.

WARNING

DO NOT operate this MEWP in enclosed areas without adequate ventilation for exhaust gas and fumes. Failure to follow this warning could cause death or serious injury.

WARNING

Failure to heed the following safety precautions could result in tip-over, falling, crushing, or other hazards leading to death or serious injury.

KNOW all national, state/provincial or territorial, and local rules which apply to your MEWP and worksite.

MAKE SURE all the safety and instructional labels are correctly attached on the MEWP in the correct location. Clean or replace labels that you cannot read.

DISCONNECT and lock out main power disconnect on the left side of the MEWP when leaving the MEWP unattended to prevent unauthorized use.



DO NOT wear jewelry or loose clothing that could become caught or entangled.



DO NOT allow the entanglement of ropes, cables or hoses with the MEWP, adjacent structures or objects.



Prevent falling from the platform. Always keep a firm footing on the platform floor when working thereon. Do not climb on the toe-board, mid-rail, or top-rail. Do not use planks, ladders, or any other devices on the platform for achieving additional height or reach.

MAKE SURE all occupants wear personal fall protection equipment.



DO NOT raise the platform or operate elevated in windy or gusty conditions that exceed the limits specified in [Section 7.7](#).



DO NOT increase the surface area of the platform or carry large surface area items when exposed to wind. Increasing the area exposed to the wind will decrease the MEWP stability.

MAKE SURE the ground condition assessment considers the subsurface voids such as cellars, basements, culverts, and pipes.



DO NOT elevate or drive elevated on a slope. Elevated driving must be done on a firm, level surface.



DO NOT drive elevated near depressions or holes of any type, loading docks, debris, drop-offs or surfaces that may affect the stability of the MEWP. IF OPERATION IN AREAS WITH HOLES OR DROP-OFFS IS ABSOLUTELY NECESSARY, elevated driving shall not be allowed. Position the MEWP horizontally only with the platform fully-lowered. After ensuring that all 4 wheels have contact with a firm, level surface, the platform can be raised. After elevation, the drive function must not be activated.



DO NOT drive elevated on a soft or uneven surface.



DO NOT raise the platform if it is not on a firm, level surface.

DO NOT ascend or descend grades greater than the maximum inclines listed in [Section 7.4](#). Ascending or descending slopes must only be done when fully lowered.



DO NOT operate a MEWP that has ladders, scaffolding, or other devices on it to increase the platform size or work height.



DO NOT exceed the maximum side force on the platform capacity label when elevated (refer to [Section 7.7](#)).



DO NOT use the MEWP as a crane.



DO NOT step on the boom arm assembly.



DO NOT sit, stand, or climb on the guardrails.



DO NOT collide or crush. Be aware of obstructions, personnel, or other possible hazards around the MEWP when elevating, lowering, or driving. Keep all body parts inside the platform when elevating or driving. Be aware of blind spots when operating the MEWP.



DO NOT use the boom to push or pull other objects, or to lift the chassis.



DO NOT use the MEWP under the influence of alcohol or drugs, or if the operator's performance is impaired by a medical condition, the influence of prescription or over the counter drugs, or fatigue.



DO NOT elevate the platform when the MEWP is on a truck, forklift, or other device or vehicle.



DO NOT use the MEWP if it does not function correctly or if any parts are damaged or worn.



DO NOT use the MEWP when the wheels or tires are damaged (refer to [Section 4.2-7](#)).
Make sure the wheel nuts are tight.



DO NOT leave the MEWP unattended with the key in the key switch.



DO NOT alter or disable limit switches or other safety devices.

DO NOT position the MEWP against another object to steady the platform.

STUNT driving and horseplay are prohibited.

DO NOT use the MEWP without guardrails, lock-pins and the entry gate/drop bar installed.

DO NOT operate on slippery surfaces without sufficient traction to stop, drive, or steer the MEWP.



DO NOT exceed the rated capacity of the MEWP.

DO NOT place materials on the guardrails or materials that exceed the confines of the guardrails unless approved by Skyjack.

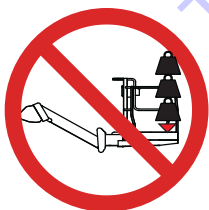

DO NOT distribute the load unevenly.

Remove all personnel from the platform before you try to free a snagged platform with the base controls.

2.3 Fall-protection

WARNING

Make sure all occupants wear personal fall protection equipment. If you do not obey, there is a risk of death or serious injury.

The guardrail system is the primary fall-protection system of the MEWP platform.

All occupants of this machine must wear personal fall-protection equipment (PFPE) at all times.

Skyjack recommends the use of a full body harness with a lanyard. PFPE must be attached only to approved fall-protection anchorage points in the platform.

All PFPE must be compliant with applicable government rules and must be inspected as per the manufacturer's recommendation.

WARNING

Fall hazard.

- Only enter and exit the MEWP using the three points of contact principle.
- Only use the equipped access openings.
- Only enter and exit the MEWP when the platform is fully lowered.
- Face the MEWP when entering or exiting the platform.

Failure to follow these instructions could result in death or serious injury.

Enter or exit the platform from the ground only. Use the three points of contact principle, which is when two hands and one foot, or one hand and two feet are in contact with the MEWP or the ground at all times. Face the MEWP when entering or exiting the platform.

2.4 Worksite inspection

Make sure the operating environment, ambient temperature, Electromagnetic Compatibility (EMC), and Hazardous Location Rating (locations with potentially flammable gases, explosive gases or particles) are appropriate for the MEWP specifications (refer to [Section 7.5](#)).

Be sure to follow all national, state/provincial/territorial, and local rules that relate to operating the MEWP.

Perform a full worksite inspection before operating the MEWP. Identify potential hazards in the area.

Be aware of moving equipment in the area. Take the necessary precautions to prevent collisions.

It is the responsibility of the operator to perform a worksite inspection and avoid/address the following hazards:

- Holes or drop-offs
- Slopes
- Ditches or soft fills
- Floor obstructions, bumps, or debris
- Overhead obstructions
- Electrical conductors
- Hazardous locations
- Inadequate surface support to withstand all load forces imposed by the MEWP (refer to [Section 7.7](#))
- Wind and weather conditions
- Presence of personnel
- Other mobile equipment
- Traffic hazards
- Equipment that could move and collide with the MEWP, such as overhead cranes
- Other possible unsafe conditions.

Section 3 – Familiarization

WARNING

Do not operate this MEWP without correct training and authorization. If you do not obey, there is a risk of death or serious injury.

WARNING

MEWP Familiarization must be given to a qualified operator. If you do not obey, there is a risk of death or serious injury.

WARNING

It is the responsibility of the operator to fully understand, and follow all instructions and warnings contained in this operation manual and on the MEWP. If you do not obey, there is a risk of death or serious injury.

Read and fully understand the operation manual, all the warnings, and the instruction labels (refer to [Section 8](#)) on the MEWP.

Do these tasks before the operation:

1. Worksite inspection. Refer to [Section 2.4](#).
2. Daily visual and maintenance inspections. Refer to [Section 4.2](#).
3. Function tests. Refer to [Section 4.3](#).

3.1 Overview of the MEWP

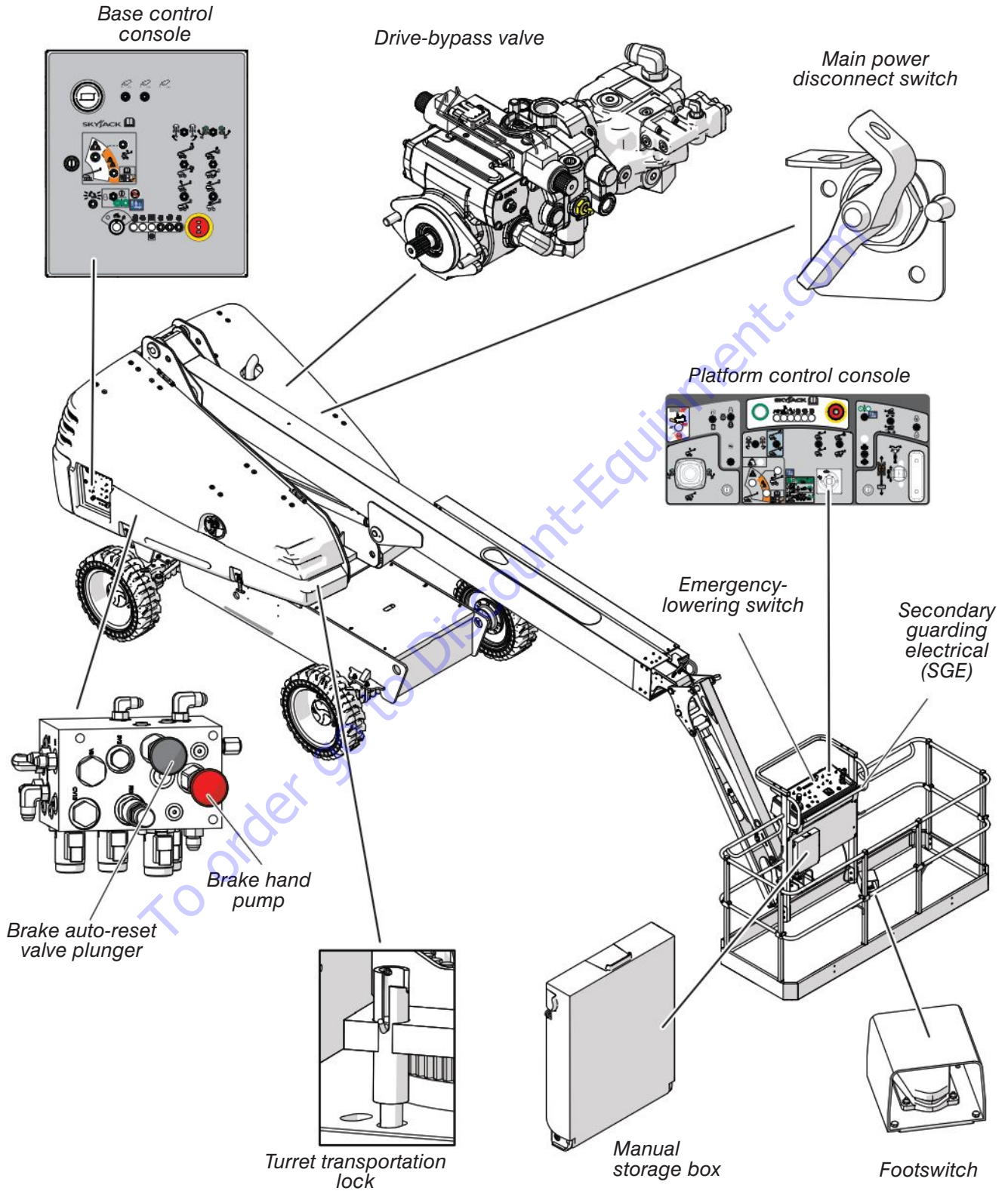

3.2 Manual storage box

The manual storage box is weather-resistant. It contains the operation manual, ANSI Manual of Responsibilities, and the ANSI/CSA certificate. You must keep the operation manual for the make and model of this MEWP in this box. Refer to [Section 3.1](#) for the location of the manual storage box.

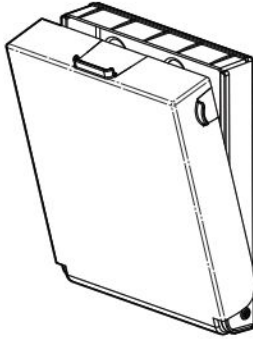

3.3-2 Footswitch

Refer to [Section 3.1](#) for the location of the footswitch. When pressed and held, it enables the controls on the platform control console.

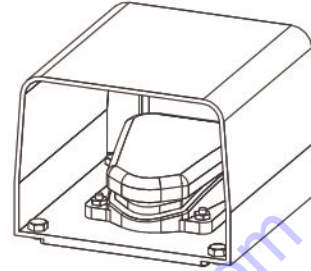

NOTE

The footswitch has a 7-second anti-tiedown feature. This feature prevents the footswitch operation when the operator presses it for 7 seconds without the activation of a function.

3.3 Control functions

3.3-1 Main power disconnect switch

Refer to [Section 3.1](#) for the location of the main power disconnect switch.

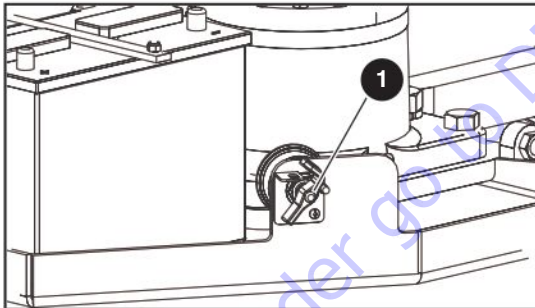

- 1 Main power disconnect:** This switch disconnects power to all control circuits when it is in the off position. The switch must be in the on position to operate the MEWP. The switch must be in the off position when you transport the MEWP or put it in storage.

3.3-3 Engine display module

The engine display module is fastened to the top of the base control console. It has a graphic LED screen with function buttons below the screen.

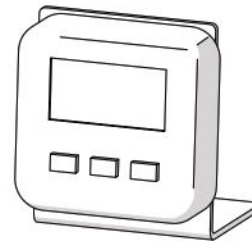

3.3-4 Positive air shut-off (optional equipment)

This switch stops the air supply to the engine. This is useful if the engine does not immediately stop when the power is off.

The switch is under a red switch guard. It is located below the coolant overflow tank on the engine.

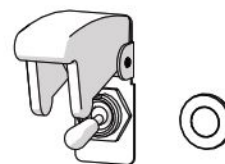

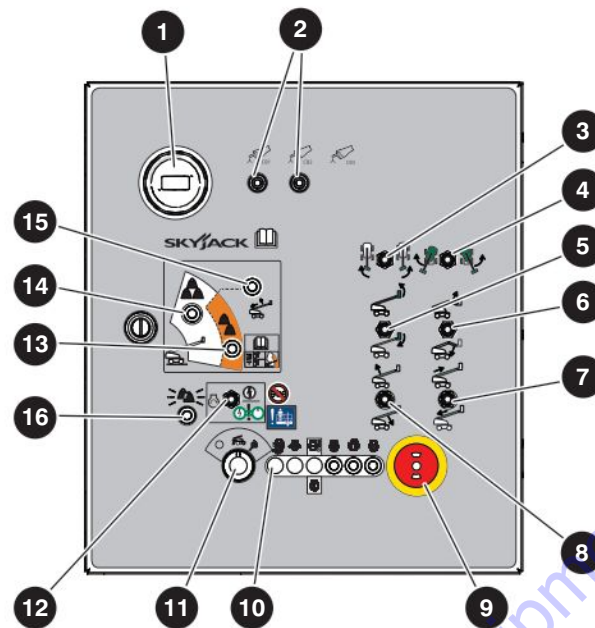

3.3-5 Base control console

Refer to [Section 3.1](#) for the location of the base control console.

- ① **Hourmeter:** This display shows the hours of operation.
- ② **Circuit breaker:** If a power overload or positive circuit grounding occurs, the circuit breaker comes out. Push the **circuit breaker** back into the initial position to reset the power.
- ③ **Platform rotation:** This switch controls the left or right rotation of the platform.
- ④ **Turret rotation:** This switch controls the left or right rotation of the turret.
- ⑤ **Platform-leveling override:** This switch overrides the automatic platform-leveling function and controls the tilt up or tilt down function of the platform.
- ⑥ **Jib up/down:** This switch controls the up or down movement of the jib.

- ⑦ **Boom extend/retract:** This switch controls the extension or retraction of the boom.
- ⑧ **Main boom raise/lower:** This switch controls the raise or lower function of the main boom.
- ⑨ **Emergency-stop:** This button disconnects power to the control circuit and stops the engine. Pull to connect the power again.
- ⑩ **Status indicator pilot lights:** These lights show the operation condition and errors in the control or engine functions.

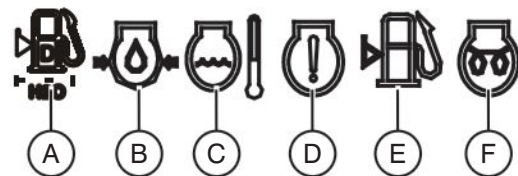

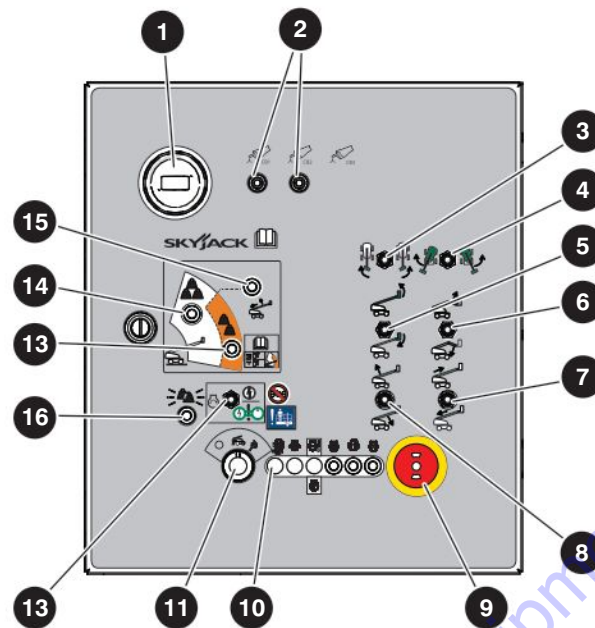

- A. **Water-in fuel:** This light shows the water separator is full. Open the drain to release the water. Engine damage can occur if ignored for too much time.
- B. **Engine oil pressure:** This light shows a low engine oil pressure.
- C. **Engine coolant temperature/level:** This light shows the engine coolant is too hot and a low level of engine coolant.
- D. **Engine:** This light shows a failure in the engine control system.
- E. **Fuel:** This light shows a low fuel level.
- F. **Glow plug (diesel engine):** This light illuminates until the glow plugs complete their timed-cycle. When the light goes off, you can start the engine.

- 11 **Off/base/platform key:** With this three-way switch, you can:
- Turn off the power to the MEWP controls.
 - Energize the base controls.
 - Energize the platform controls.

- 12 **Start/function enable/emergency-power:** In the start position, this switch starts the engine. In the function enable position, this switch lets the base control functions operate. The engine speed increases when the function enable position is selected. In the emergency-power unit position, with the engine off, this switch lets the base control functions operate with the emergency-power unit.

⚠ WARNING

Do not operate the boom functions if the platform capacity is more than the rated platform capacity.

- 13 **Low-capacity zone indicator:** This light shows the MEWP is in the low platform capacity zone. Refer to [Section 7.7](#).
- 14 **High-capacity zone indicator:** This light shows the MEWP is in the high platform capacity zone. Refer to [Section 7.7](#).
- 15 **Capacity zone border light:** This light shows the MEWP is at the limits of travel for the high-capacity zone. The lower and extend functions are not available.
- 16 **Overload light:** This red light shows an overload status. Refer to [Section 3.4-7](#).

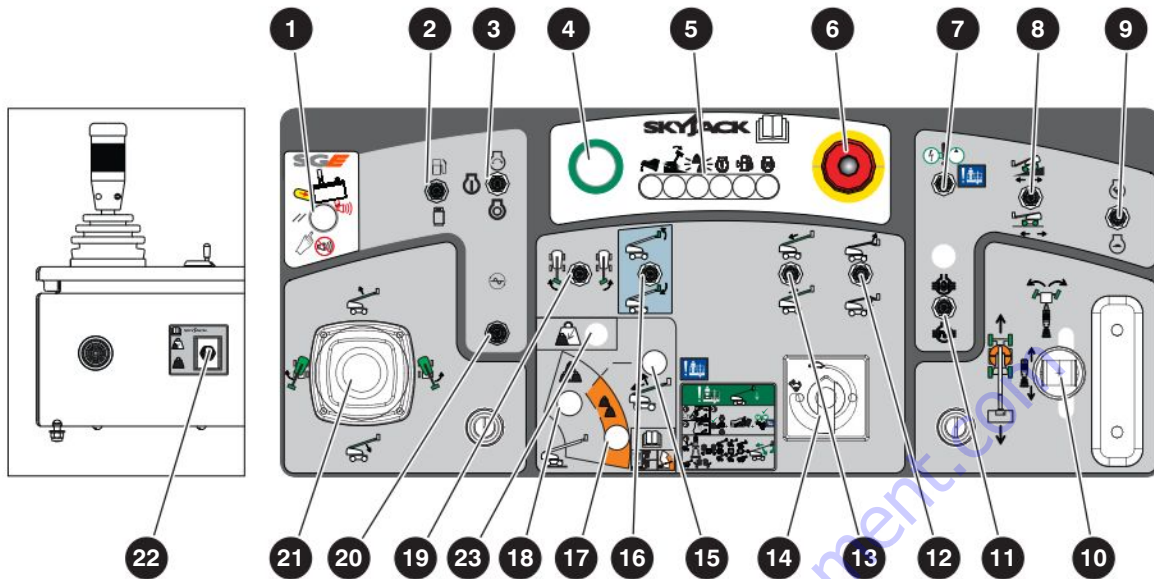

3.3-6 Platform control console

Refer to [Section 3.1](#) for the location of the platform control console.

- 1 **Secondary guarding electrical (SGE) reset:** This button, when pressed, stops the SGE audible/visual alarm.
- 2 **Fuel selector (dual fuel):** Use this switch to select liquid propane gas or gasoline as the fuel type.
- 3 **Engine start/on/off:** In the start position, this switch starts the engine. When the engine starts, this switch goes back to the on position. In the off position, this switch stops the engine.
- 4 **Horn:** This push-button makes a sound like a car horn.
- 5 **Status indicator pilot lights:** These lights show the operation condition and errors in the control or engine functions.

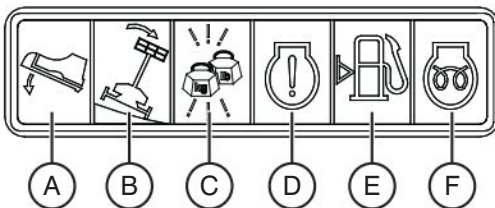

- A. **Footswitch:** This light illuminates when the footswitch is pressed. A 7-second anti-tiedown feature prevents the footswitch operation when the operator presses it for 7 seconds without the activation of a function.
- B. **Chassis tilt:** This light illuminates when the MEWP chassis is at an inclination that activates the tilt switch. At this inclination, an alarm will make a sound at the platform. Refer to [Section 6.2](#) for instructions on recovery from an inclined position.
- C. **Overload:** This red light shows an overload status. Refer to [Section 3.4-7](#).
- D. **Engine:** This light shows a failure in the engine control system.
- E. **Fuel:** This light shows a low fuel level.
- F. **Glow plug (diesel engine):** This light illuminates until the glow plugs complete their timed-cycle. When the light goes off, you can start the engine.

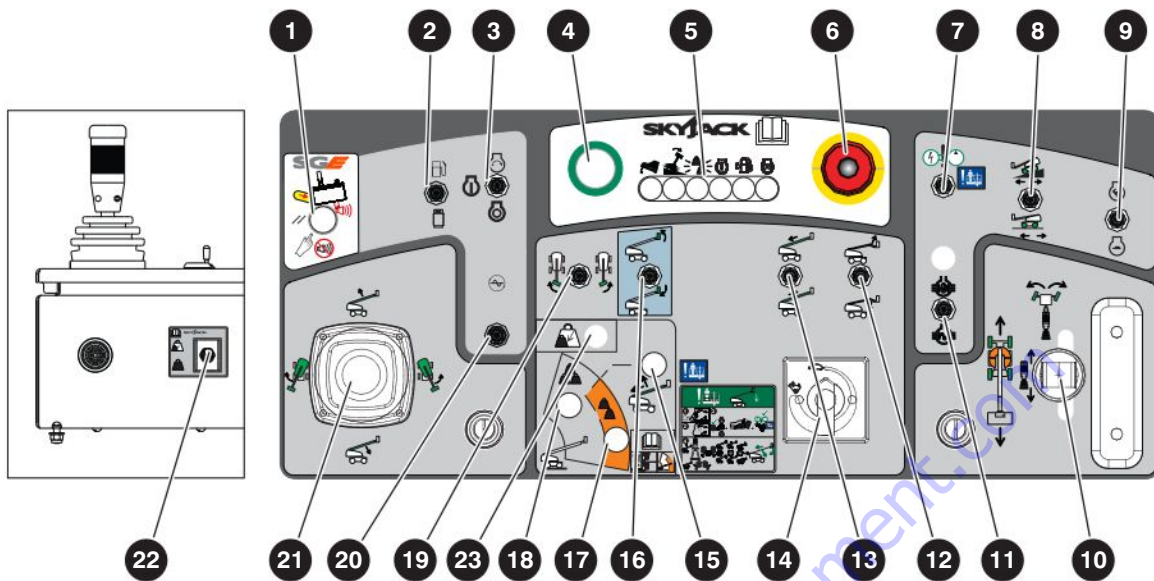

- 6 **Emergency-stop:** This button disconnects power to the control circuit and stops the engine. Pull to connect the power again.
- 7 **Emergency-power unit:** This switch enables the emergency-power unit when the engine is off.
- 8 **Torque:** This switch selects low or high torque. Select low torque (high speed) or high torque (low speed). Select high torque when you drive on a slope.
- 9 **Low/high throttle:** This switch selects low or high engine throttle speeds.
- 10 **Drive/steer controller:** This single-axis lever controls the drive movements. To return it to the initial neutral position, release the controller. The rocker switch controls the left and right steering. Internal springs return the rocker switch to the initial neutral position when it is released.
- 11 **Differential lock:** This switch, when pushed forward and then released, engages the differential lock and turns the differential light on. When this switch is pulled back and then released, it disengages the differential lock and turns the differential light off.
- 12 **Jib up/down:** This switch controls the up or down movement of the jib.
- 13 **Boom extend/retract:** This switch controls the extension or retraction of the boom.
- 14 **Function speed adjuster:** This variable speed adjuster controls speed of boom extension/retraction, jib raising/lowering and platform rotation movements. This is used with switches 12, 14 and 20.
- 15 **Capacity zone border light:** This light shows the MEWP is at the limits of travel for the high-capacity zone. The lower and extend functions are not available.
- 16 **Platform-leveling override:** This switch overrides the automatic platform-leveling function and controls the tilt up or tilt down function of the platform.
- 17 **Low-capacity zone indicator:** This light shows the MEWP is in the low platform capacity zone. Refer to [Section 7.7](#).

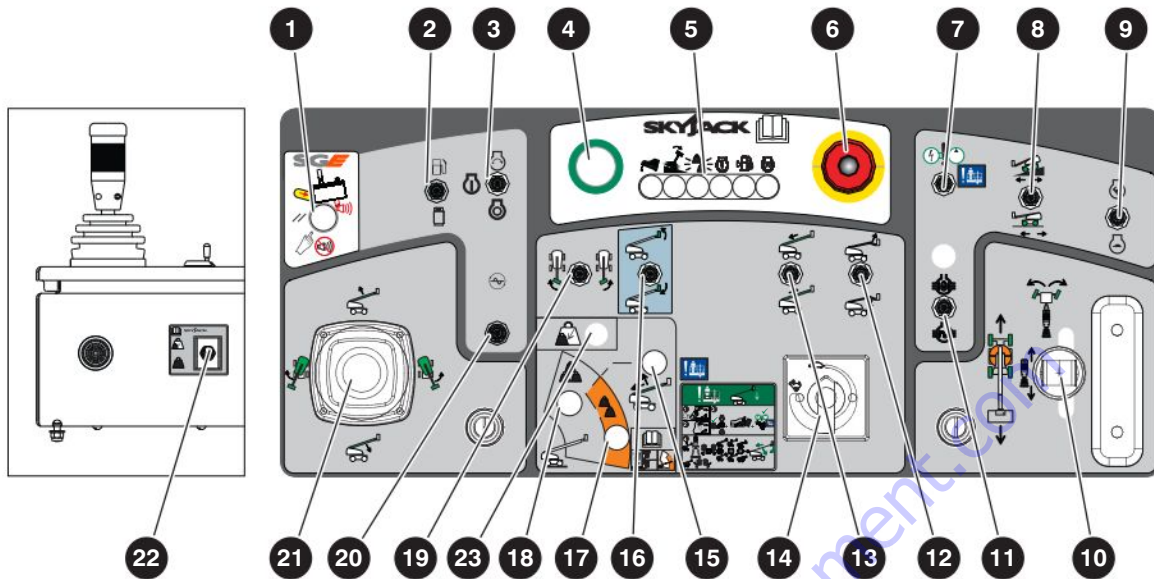

- 18 **High-capacity zone indicator:** This light shows the MEWP is in the high platform capacity zone. Refer to [Section 7.7](#).
- 19 **Platform rotation:** This switch controls the left or right rotation of the platform.
- 20 **Generator on/off (optional equipment):** This switch turns the generator on or off.
- 21 **Boom/turret controller:** This dual-axis lever controls the raise or lower function of the main boom, and the left or right rotation of the turret.
- 22 **Capacity derate switch:** This switch controls the platform capacity. This switch derates the platform capacity to adapt to specified attachments. Refer to [Section 5.23](#), [Section 5.24](#) for operation, [Section 7](#) for specifications and [Section 8](#) for platform capacity label.
- 23 **Capacity derate light:** This light illuminates when the capacity derate switch is selected. It indicates the reduction in platform capacity. Refer to [Section 5.23](#), [Section 5.24](#) for operation, [Section 7](#) for specifications and [Section 8](#) for platform capacity label.

3.4 Features and devices

3.4-1 Lowered travel position and elevated travel position

The available MEWP functions depend on these factors:

- MEWP configuration (lowered travel position/ elevated travel position)
- Chassis tilt
- Platform load
- Boom position (high/low-capacity)

The MEWP is in the lowered travel position if it is in ALL of the positions shown in *Figure 01*.

The MEWP is in the elevated travel position if it is in ANY of the positions shown in *Figure 02*.

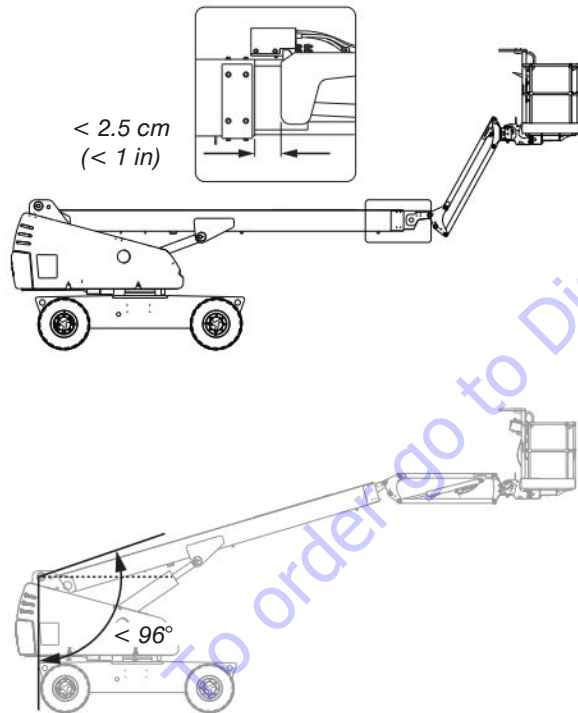

Figure 01 Lowered travel position

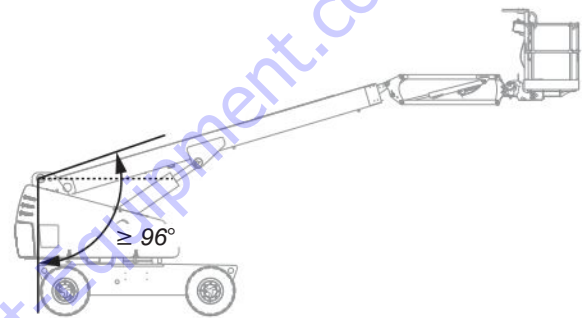
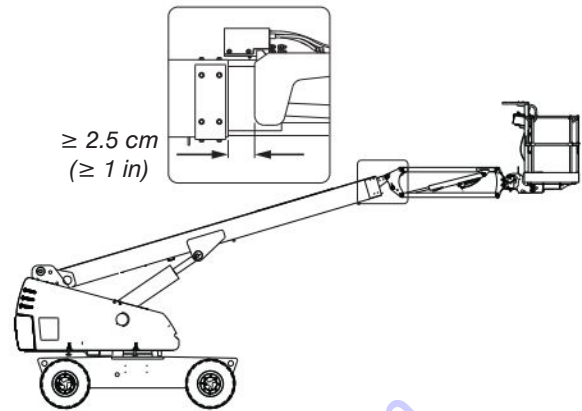

Figure 02 Elevated travel position (any of the boom positions shown)

3.4-2 Drive speed

The drive speed depends on the MEWP configuration (lowered travel position/elevated travel position). When the MEWP is in the elevated travel position, the speed is slower than the speed in the lowered travel position. Refer to [Section 7.4](#).

3.4-3 Drive direction

The drive function operates in relation to the general orientation of the turret counterweight on the chassis (i.e., when the controller handle is forward, the counterweight faces forward). Thus, the MEWP will move in the general direction of the controller handle movement.

3.4-4 Tilt switch

The tilt switch is in the base control console. *When the MEWP tilts more than a predetermined limit:*

- an alarm makes a sound
- a light illuminates
- the boom movement and drive functions are disabled (refer to [Section 3.4-5](#)).

WARNING

Tip-over hazard. When the MEWP tilts more than a predetermined limit, the alarm makes a sound, and the light illuminates. The platform must be lowered and retracted immediately. Refer to [Section 6.2](#) for the instructions on how to recover from an inclined position. If you do not obey, there is a risk of death or serious injury.

3.4-5 Function restrictions when the MEWP is tilted

Mode/Condition	Indicator Light	Audible Alarm	Restrictions	Emergency Power (Platform)	Emergency Power (Base)
Lowered travel position, tilted	Disabled	Disabled	No restriction	Enabled	Enabled
In lowered travel position, tilted, moving into elevated travel position (at the limits of the lowered travel position)	Enabled	Enabled	Boom Extension, Boom Up	Enabled	Enabled
Elevated travel position, tilted	Enabled	Enabled	Drive disabled	Enabled	Enabled

1952AA

NOTE

If you reset power to the controls (i.e. push and pull the emergency-stop button) when the MEWP is tilted, and at the limits of the lowered position, the MEWP will be in the “tilted while elevated” condition.

3.4-6 Platform load sensing system

The platform load-sensing system prevents normal MEWP movement when the platform is overloaded and in a stationary position.

The boom position (extension and angle) and the capacity derate switch position have an effect on the platform capacity. Each boom position zone (high-capacity zone or low-capacity zone) has a different capacity. Refer to the platform capacity label(s) for the maximum platform capacity of each zone.

WARNING

If the platform is overloaded because of contact with an overhead obstruction, do one of the steps that follow:

- Remove the obstruction from the platform. Then after four-seconds, you can operate the normal functions.
- Use the emergency-power unit to release the platform from the obstruction (refer to [Section 3.4-7](#)).

WARNING

Fall hazard. Do not try to free a snagged platform with the base controls until you remove all personnel from the platform. If you do not obey, there is a risk of death or serious injury.

3.4-7 Overload status

Mode/Condition	Indicator Light	Zone Border Light	Audible Alarm	Drive Functions	Powered Boom Functions	Emergency Power (Platform)	Emergency Power (Base)
The platform is near the rated load	On	Off	Off	Enabled	Enabled	Enabled	Enabled
In the lowered travel position: the load on the platform is more than the rated load	Flashing	Off	Pulsing	Enabled	Enabled	Enabled	Enabled
In the elevated travel position: the load on the platform is more than the rated load	Flashing	Off	Pulsing	Disabled	Disabled	Enabled	Enabled
In the elevated travel position and the boom is extended or the boom is lowered to the border between the high and low capacity zones: the load on the platform is more than the rated load for the low capacity zone. *	Off	On	Off	Enabled	Boom raise and Boom retract only	Enabled	Enabled

* If you reset power to the controls (for example, push and pull the emergency-stop button) when the MEWP is in this mode, the MEWP will be in the overload condition when elevated.

1885AA

NOTE

Movement into the low-capacity zone occurs when the boom is lowered or extended into a position where it is raised less than **A** degrees and extended **D** m (**D** ft). Refer to [Figure 03](#) and [Figure 04](#).

WARNING

Movement into the low-capacity zone is restricted if the platform capacity is more than the low-capacity zone platform capacity. Refer to [Section 3.4-7](#).

WARNING

If the platform load sensing system is in the fault mode, the capacity lights flash alternately and the overload light flashes. The capacity zone border light continuously illuminates as well. Do the steps that follow:

- Make sure the platform is level, and there are no obstructions in contact with the platform.
- If the platform load sensing system stays in the fault mode, the emergency-power unit can be used to lower the platform. Remove the MEWP for servicing. Speak to a qualified service technician for repairs. If you do not obey, there is a risk of death or serious injury.

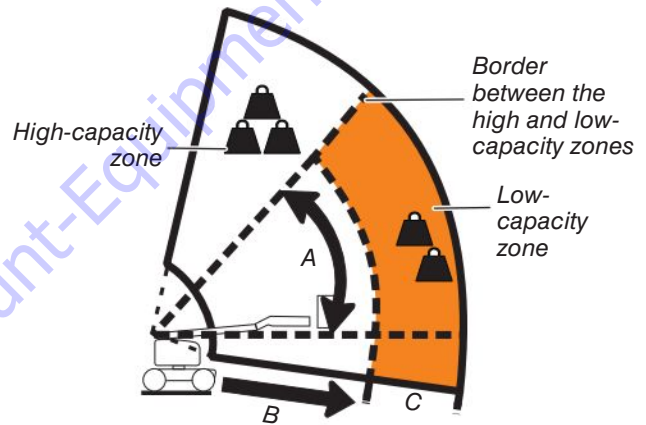

Model	Angle (A)	Boom Length (B)	Low Capacity Zone Length (C)
SJ40 T+	60°	9.80 m (32 ft)	2.13 m (7 ft)
SJ45 T+	60°	11.57 m (38 ft)	2.13 m (7 ft)

Figure 03 High and low-capacity zones

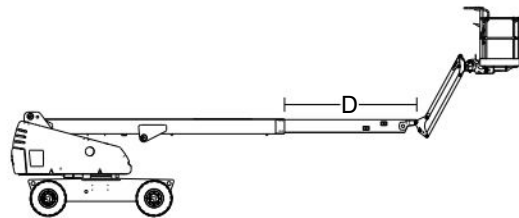

Model	SJ40 T+	SJ45 T+
D	2.51 m (8 ft)	2.51 m (8 ft)

Figure 04 Boom extension into the low-capacity zone

3.4-8 Brake-release system

This system disengages the brakes manually before you winch or tow the MEWP. Refer to [Section 6.3](#) for the procedure. Refer to [Section 3.1](#) for the location of the brake-release system.

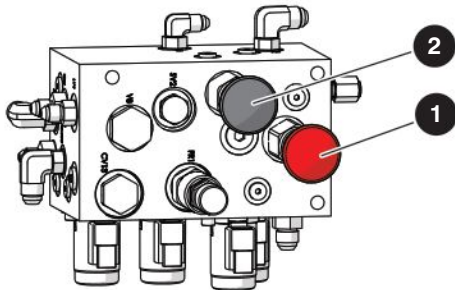

- 1 Brake hand pump
- 2 Brake auto-reset valve plunger

3.4-9 Secondary guarding electrical (SGE)

This device prevents sustained involuntary operation of the MEWP from accidental contact with the platform controls. The audible/visual alarm lets personnel know that pressure has been applied to the sensor bar.

⚠ WARNING

This device will not prevent a collision or injuries that can result from a collision.

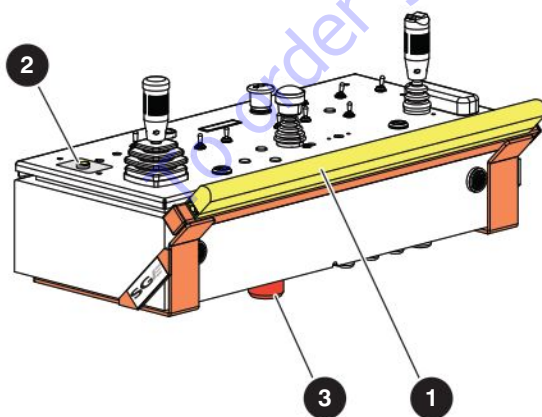

- 1 **Sensor bar:** This bar is in front of the platform control console. When you apply pressure to the sensor bar, it stops all functions.
- 2 **Reset:** This button is on the top left corner of the platform control console. It illuminates when you apply pressure to the sensor bar for more than 1 second. When you press this button, it stops the audible/visual alarm.
- 3 **Audible/visual alarm:** This alarm is on the bottom of the platform control console. It goes on when you apply pressure to the sensor bar.

SGE operation

1. When you apply pressure to the sensor bar for less than 1 second, the audible/visual alarm goes on while the bar is pressed. All functions stop. The audible/visual alarm goes off after the sensor bar is released, and the functions are available again.
2. When you apply pressure to the sensor bar for more than 1 second, the audible/visual alarm goes on and the engine stops. All functions stop. The reset button illuminates. The emergency-power functions are available.
3. After you remove pressure from the bar, press the reset button to stop the audible/visual alarm and make all functions available.

3.4-10 Drive-bypass valve

This valve is on the inboard side of the drive pump. A yellow paint mark identifies the valve.

Refer to [Section 3.1](#) for the location of the drive bypass valve.

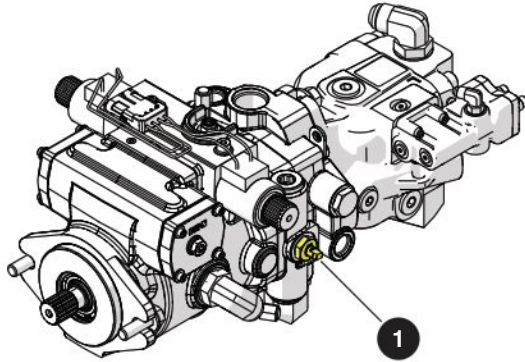

- 1 Drive-bypass valve with an override stem -**
 This valve, when loosened 90 degrees clockwise, overrides the drive relief valves so the MEWP can be loaded or unloaded from a trailer with a winch line. Refer to [Section 6.4](#) for the winch and tow procedure.

3.4-11 AC power socket on the platform

The AC power socket is a source of AC power on the platform. The outlet is on the right side of the platform control console, and the plug is adjacent to the hydraulic tank in the control compartment.

3.4-12 Motion alarm

This alarm makes a sound when you operate any boom or drive function. On MEWPs with certain options, a flashing amber light accompanies this alarm.

3.4-13 Differential lock switch

This switch is on the platform control console. The differential lock system gives equal drive to each wheel regardless of the terrain, which gives the wheels more traction. The differential locks are used to prevent the MEWP from getting stuck when you drive on loose, muddy, or rocky terrain. Refer to [Section 4.3-22](#) for the instructions on how to do a test of the differential lock switch.

3.4-14 Turret transportation lock

This lock device is in the turret.

Refer to [Section 3.1](#) for the location of the lock.

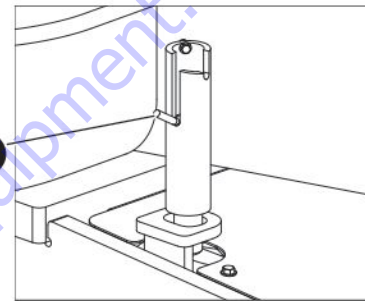

- 1 Turret transportation lock -** This lock device is used to lock turret in position when you transport the MEWP. Refer to [Section 6.6-1](#) for the procedure on how to lock the turret.

3.5 Optional equipment

CAUTION

Skyjack approved modifications and attachments can change the MEWP specifications. Refer to the applicable instructions and labels.

IMPORTANT

Refer to the labels of the optional equipment for the actual weight. Include this weight to calculate the total load on the platform. Include personnel and other materials in the total load.

The weight of the attached parts, panels, occupants, and tools put together must not be more than the rated platform capacity.

NOTE

Refer to the website (www.skyjack.com) for other optional equipment.

3.5-1 AC power socket on the platform

The AC power socket is a source of AC power on the platform. The outlet is on the right side of the platform control console, and the plug is adjacent to the hydraulic tank in the control compartment.

3.5-2 Flashing amber light

The flashing amber light is on top of the turret of the MEWP.

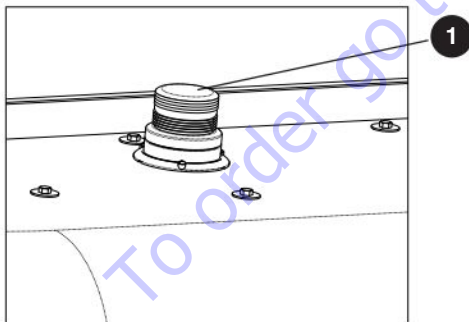

- 1 **Flashing amber light:** This light flashes when you operate a boom function. It operates with the motion alarm.

3.5-3 Welder

The welder is installed on the platform. Refer to the welder operation manual for the correct operation and maintenance.

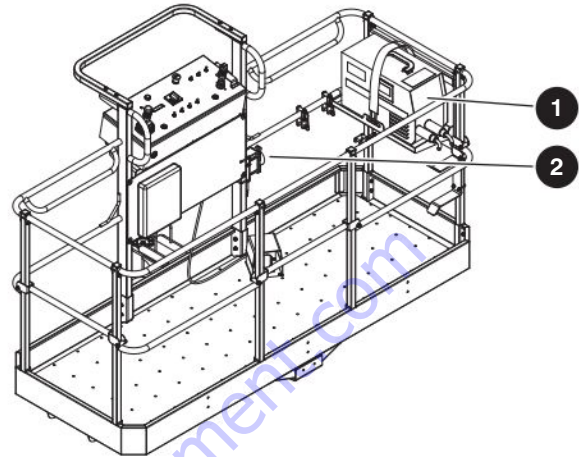

- 1 **Welder:** This equipment is connected to the welder AC socket on the platform.
- 2 **Welder AC socket:** This AC socket is for the welder.

NOTE

In temperatures below 0°C (32°F), make the hydraulic oil warm before you operate the welder.

WARNING

Only a qualified service technician must install, operate, do maintenance on, and repair the welder.

CAUTION

If you breathe in welding fumes and gases, it can be hazardous to your health.

3.5-4 Cold or arctic weather package

The battery warmer (cold and arctic), hydraulic oil heater (arctic), and engine oil heater (arctic) cables are in the engine compartment near the engine.

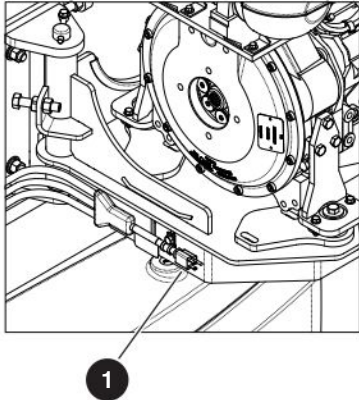

- ❶ **Cold package battery warmer cable:** Connect this cable to an AC socket for a minimum of 4 hours before you start the engine when the temperature is below -10°C ($+14^{\circ}\text{F}$).
- ❶ **Arctic package battery/hydraulic oil/engine oil heater cable:** Connect this cable to an AC socket for a minimum of 4 hours before you start the engine when the temperature is below -18°C (0°F).

3.5-5 Tool Tray

The tool tray attaches to a corner of the top platform railings with lock-pins.

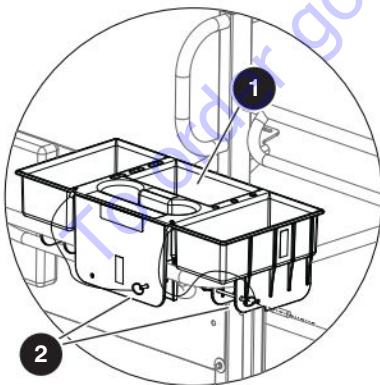

- ❶ **Tray:** The tray holds tools.
- ❷ **Lock-pins:** The lock-pins secure the tray to the railings.

3.5-6 Glazier

The glazier tray attaches to the kickplate of the platform. Refer to the glazier operation manual for the correct operation and maintenance.

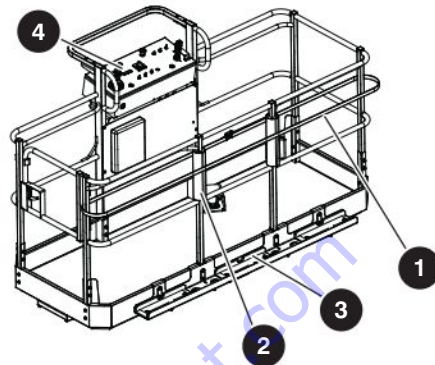

- ❶ **Strap:** The strap holds the panel in position.
- ❷ **Foam Support:** The foam support gives protection to the panel.
- ❸ **Glazier Tray:** The tray holds the panel.
- ❹ **Derate Switch:** This switch controls the platform capacity.

⚠ WARNING

Tip-over hazard. When required by Skyjack-approved attachment or modifications, use the capacity derate switch. If you do not obey, there is a risk of death or serious injury.

IMPORTANT

The platform capacity changes with the boom position or capacity derate switch position. The indicator lights on the base and platform control consoles show if the platform is in the high or low capacity zone.

3.5-7 Pipe Rack

The pipe rack attaches to the top platform railings. Refer to the pipe rack operation manual for the correct operation and maintenance.

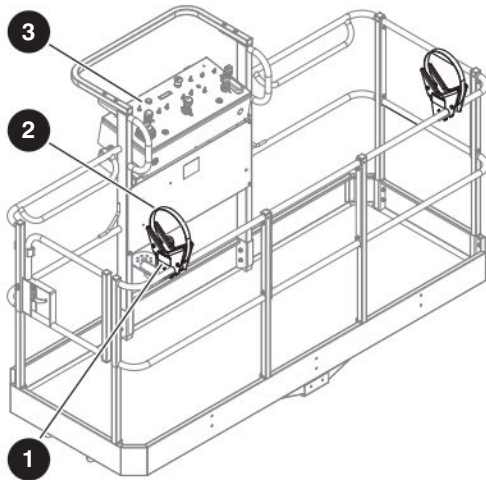

- 1 **Cradle:** The cradles hold the pipes.
- 2 **Strap:** The straps secure the pipes to the cradle.
- 3 **Derate Switch:** This switch controls the platform capacity.

WARNING

Tip-over hazard. When required by Skyjack-approved attachment or modifications, use the capacity derate switch. If you do not obey, there is a risk of death or serious injury.

IMPORTANT

The platform capacity changes with the boom position or capacity derate switch position. The indicator lights on the base and platform control consoles show if the platform is in the high or low capacity zone

3.5-8 Elevate™ telematics - access control unit

Access control is an added function of the Elevate™ Trackunit. The access control function does not have an effect on: emergency-lowering, secondary guarding electrical, load sensing, the horn, and when you lower the platform. These functions are always available. The access control unit does not allow the engine to operate without an approved code or card.

IMPORTANT

The owner is responsible to supply PIN codes or Smart ID cards for MEWPs that have the access control function. Skyjack does not supply or reset PIN codes or Smart ID cards. Speak to the MEWP owner to help you with PIN codes or Smart ID cards that do not function, or you cannot find.

With the access control function, the user can control access to the MEWP operation. You can get unique PIN codes or Smart ID cards to unlock and start the MEWP. For this function, an Elevate™ telematics device and an access control keypad are necessary. With the Trackunit Manager, the MEWP owner can customize the access control to the MEWP (<https://www.trackunit.com/services/manager/>). Speak to the MEWP owner to help you with PIN codes or Smart ID cards that do not function, or you cannot find.



Figure 05 Keypad of the access control unit

- 1 **Orange indicator:** This light shows that the access control unit is ON. The keypad always has power regardless of the emergency-stop, off/base/platform key switch, or main power disconnect position.
- 2 **Green/red indicator:** A green light shows that the access control unit is in operation. A red light that flashes shows that the keypad received a cancel input.

Operation

To operate the MEWP, the light and all of these power connections must be ON before the set time expires. This set time is the time that the MEWP owner sets for the access control operation.

- The green light on the keypad of the access control unit.
- The main power disconnect switch.
- The emergency-stop button on the base control console.
- The off/base/platform key switch.

You can also set these power connections to ON before you start the access control unit.

To operate the access control unit, use the PIN code or Smart ID card.

With the Keypad:

NOTE

This touch-sensitive keypad beeps to identify a correct input.

1. Enter the PIN code.
2. Press the **green checkmark** to confirm.
 - **Result:** The green light identifies an approved ID. Start the operation.

NOTE

If you push an incorrect button when you enter the PIN code, push the Cancel button to start again.

With the Smart ID Card:

1. Put the card in front of the reader.
2. A beep identifies that the reader read the card.
 - **Result:** The green light identifies an approved ID. Start the operation.

IMPORTANT

If the set time of the access control unit expires, enter the PIN code or tap the Smart ID card again. If there is a failure of the access control activation, speak to the MEWP owner.

IMPORTANT

The access control unit will not operate if these power connections are not ON in the set time, or if the operator disconnects them:

- The main power disconnect switch
- The emergency-stop button on the base control console
- The off/base/platform key switch.

IMPORTANT

To start the access control unit, enter the PIN code or tap the Smart ID card. These power connections must be in the ON position in the set time:

- The main power disconnect switch
- The emergency-stop button on the base control console
- The off/base/platform key switch.

Function Tests

Do the function tests as specified in [Section 4.3](#).

When you do the function tests, make sure that the green light on the keypad is ON. This light confirms that the access control unit is in operation. Do the function tests for these power connections in the set time:

- The main power disconnect switch
- The emergency-stop button on the base control console
- The off/base/platform key switch.

Section 4 – Inspections Before Operation

4.1 Operator's responsibility

Do these tasks before each work shift and in this sequence:

1. **Visual and daily maintenance inspections**
(refer to [Section 4.2](#)).

WARNING

Do an inspection on the MEWP for damage or loose or missing parts. If damage is found, lock and tag the MEWP and remove it from service. If you do not obey, there is a risk of death or serious injury.

2. **Function tests** (refer to [Section 4.3](#)).

Refer to [Section 4.4](#) for a checklist of the inspection items.

WARNING

If the MEWP is damaged or has been modified from the initial factory-delivered condition, without permission from Skyjack, lock and tag the MEWP. Remove the MEWP from service. If you do not obey, there is a risk of death or serious injury.

Repairs to the MEWP are tasks only for a qualified service technician. Do the visual and daily maintenance inspections and function tests again after the repairs.

Scheduled maintenance inspections are a task only for a qualified service technician.

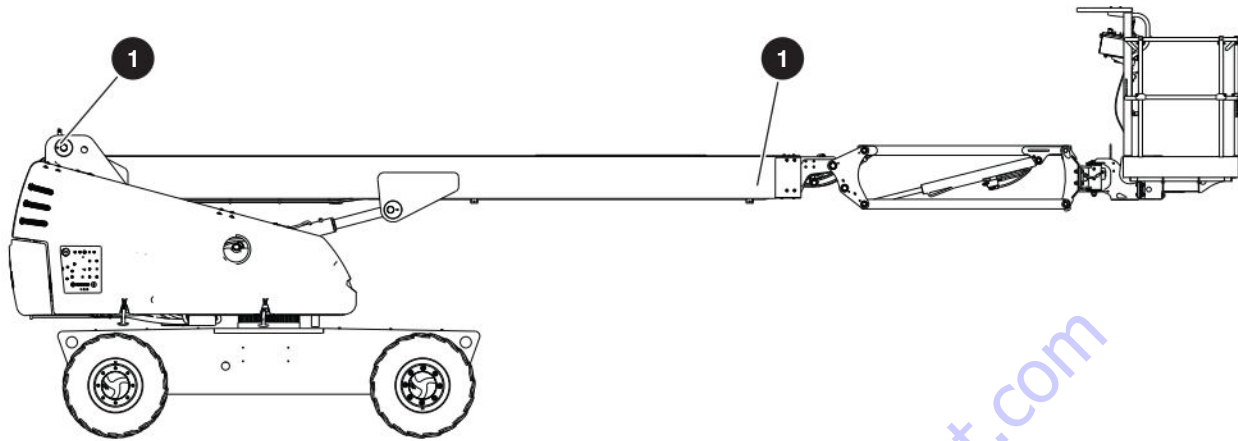
Limit switch locations

4.2 Visual and daily maintenance inspections

Do an inspection of the MEWP in this sequence.

⚠ WARNING

Do not operate a MEWP that does not function correctly. Lock and tag the MEWP, and remove it for servicing. Only a qualified service technician must repair the MEWP. If you do not obey, there is a risk of death or serious injury.

⚠ WARNING

Turn the main power disconnect switch to the off position before you do the visual and daily maintenance inspections. If you do not obey, there is a risk of death or serious injury.

⚠ CAUTION

Make sure that the MEWP is on a firm, level surface before you do the visual and daily maintenance inspections. If you do not obey, there is a risk of machine damage.

NOTE

When you do the visual and daily maintenance inspections, make sure you do an inspection of the limit switches, electrical components, and hydraulic components.

4.2-1 Labels

Refer to [Section 8](#) in this manual for the labels. Make sure all the labels are in the correct location, are in good condition, and you can read them.

4.2-2 Electrical

Do a check on these areas for chafed, corroded, and loose wires:

- Boom to platform cable harness
- Engine compartment electrical panel
- Engine wiring harness
- Rotary manifold wiring.

4.2-3 Limit switches

Make sure the limit switches **1** are correctly attached with no visible damage, and the movement is not blocked.

4.2-4 Hydraulic

Do a check on these areas and make sure there are no signs of leakage:

- Hydraulic tank filter, fittings, hoses, emergency-power unit, turret and base surface
- Engine compartment fittings, hoses, primary pump, filter, turret and base surface
- All hydraulic cylinders
- All hydraulic manifolds
- The ground area below the MEWP.

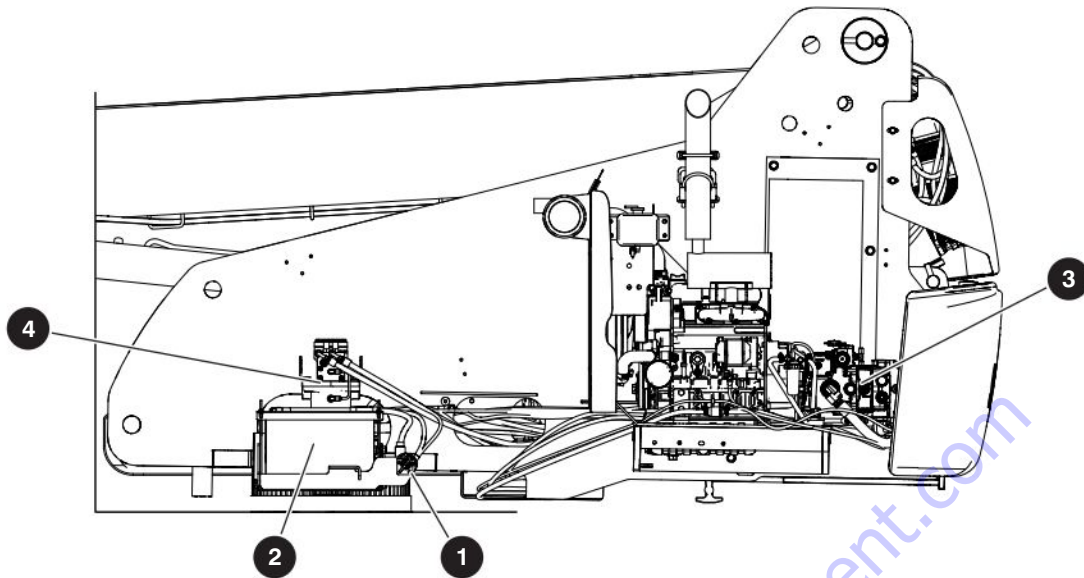

4.2-5 Engine compartment

Do the inspection that follows:

Make sure all compartment latches are latched tightly and in good condition.

1 Main power disconnect switch

- Turn the **main power disconnect** switch to the off position.
- Make sure the switch rotates and stays in the on and off position.
- Make sure the cables are not loose.

2 Batteries

⚠ WARNING

Explosion hazard. Keep flames and sparks away. Do not smoke near the batteries. Batteries release explosive gas while you charge them. Charge the batteries in a well-ventilated area. If you do not obey, there is a risk of death or serious injury.

⚠ WARNING

Corrosion hazard. Do not touch battery acid. Wear the correct PPE. If the battery acid touches you, immediately flush the area with cold water and get medical aid.

1. Do an inspection of the battery case for damage.
2. Make sure all the battery connections are tight.

3. If applicable, check the battery fluid levels. If the plates do not have a minimum 13 mm (1/2 inch) of solution above them, add distilled or demineralized water.

⚠ WARNING

Only use original or manufacturer-approved parts and components for the MEWP. If you do not obey, there is a risk of death, serious injury, or machine damage.

3 Hydraulic pump and motor

- Make sure there are no loose or missing parts.
- Make sure there is no visible damage.
- Make sure all bolts are correctly tightened.
- Make sure all fittings and hoses are correctly tightened and there are no hydraulic leaks.

4 Swing drive

- Make sure there are no loose or missing parts.
- Make sure there is no visible damage.
- Make sure all bolts are correctly tightened.
- Make sure all fittings and hoses are correctly tightened and there are no hydraulic leaks.

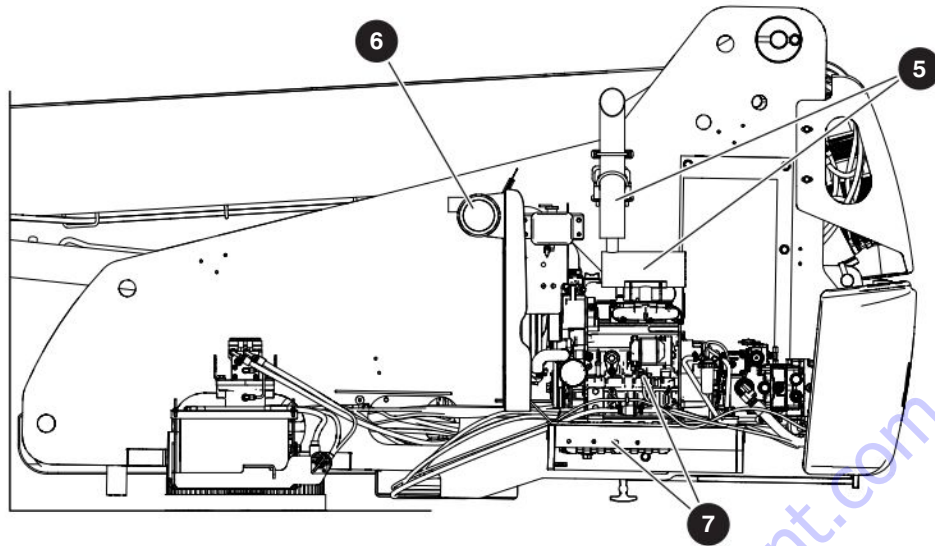

5 Muffler and exhaust

- Make sure that the muffler and exhaust systems are correctly attached with no visible damage.

6 Engine air intake filter

- Make sure there are no loose or missing parts.
- Make sure there is no visible damage.
- Squeeze the lips of the vacuator valve to remove the dirt and dust.
- Do an inspection of the service indicator on the air cleaner. Replace the filter element if necessary.

7 Engine and engine pivot tray

⚠ WARNING

Burn hazard. Do not touch hot engine components without the correct PPE. Let the engine cool before you do an inspection or servicing. If you do not obey, there is a risk of death or serious injury.

- Make sure there are no loose or missing parts.
- Make sure there is no visible damage to the engine and engine pivot tray.
- Make sure that the engine is correctly attached to the pivot tray.

Engine oil level

- Use the dipstick to check the oil level.
- The oil level must be between the marks L (low) and H (high). Add oil if it is necessary. Refer to the service manual for the recommended oil type.

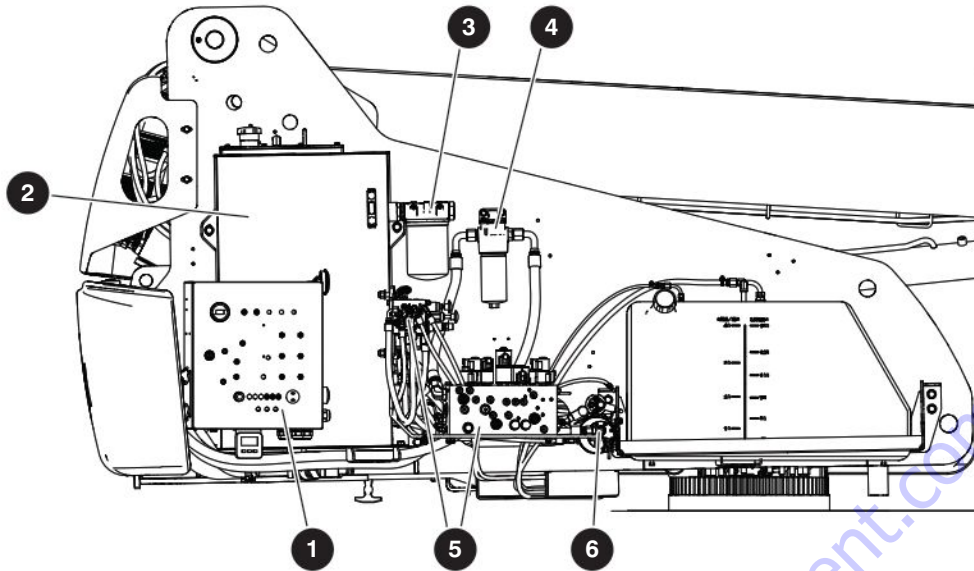

4.2-6 Control compartment

Do the inspection that follows:

Make sure all compartment latches are latched tightly and in good condition.

1 Base control console

- Make sure there are no loose or missing parts.
- Make sure there is no visible damage, and all the switches are in their off/neutral positions.

2 Hydraulic tank

- Make sure the hydraulic filler cap closes tightly.
- Make sure there is no visible damage or hydraulic leaks.

Hydraulic oil level:

- Make sure the boom is in the stowed position.
- Do a check on the **gauge** on the side of the hydraulic oil tank. The hydraulic oil level must be at or a small distance above the top mark of the gauge. Add oil if it is necessary. Refer to the service manual for the recommended oil type.

3 Hydraulic return filter

- Make sure the filter element is attached and tight.
- Make sure there is no visible damage or hydraulic leaks.

4 High-pressure filter

- Make sure the housing is attached and tight.
- Make sure there is no visible damage or hydraulic leaks

5 Manifolds

- Make sure all fittings and hoses are correctly tightened.
- Make sure there is no indication of hydraulic leakage.
- Make sure there are no loose wires or missing fasteners.

6 Emergency-power unit

- Make sure there are no loose or missing parts.
- Make sure there are no loose wires or missing fasteners.
- Make sure there is no visible damage.
- Make sure all the fittings and hoses are correctly tightened and there are no hydraulic leaks.

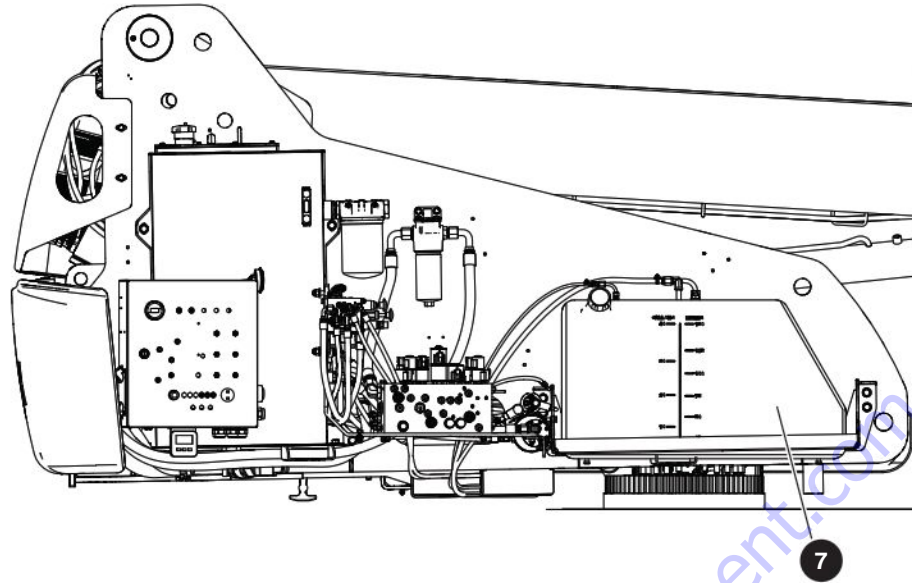

7 Fuel tank

⚠ WARNING

Explosion or fire hazard. Do not smoke near the fuel system. If you do not obey, there is a risk of death or serious injury.

IMPORTANT

Before you use the MEWP, make sure there is sufficient fuel for the estimated task.

- Make sure that the fuel filler cap closes tightly.
- Make sure there is no visible damage to the tank, gauge, hoses, or fittings.
- Make sure there is no indication of fuel leakage from the tank, gauge, hoses, fittings, pump, and filter.

⚠ WARNING

Environmental hazard. Immediately remove gasoline, diesel fuel, engine oil, and hydraulic fluid spills and leaks with rags. Discard these rags in accordance with national, state/provincial/territorial, and local regulations. Spilled fluids can damage the environment. When spilled fluids go into the water (for example, a sewage system, streams, rivers, or other surface water), they can kill aquatic life.

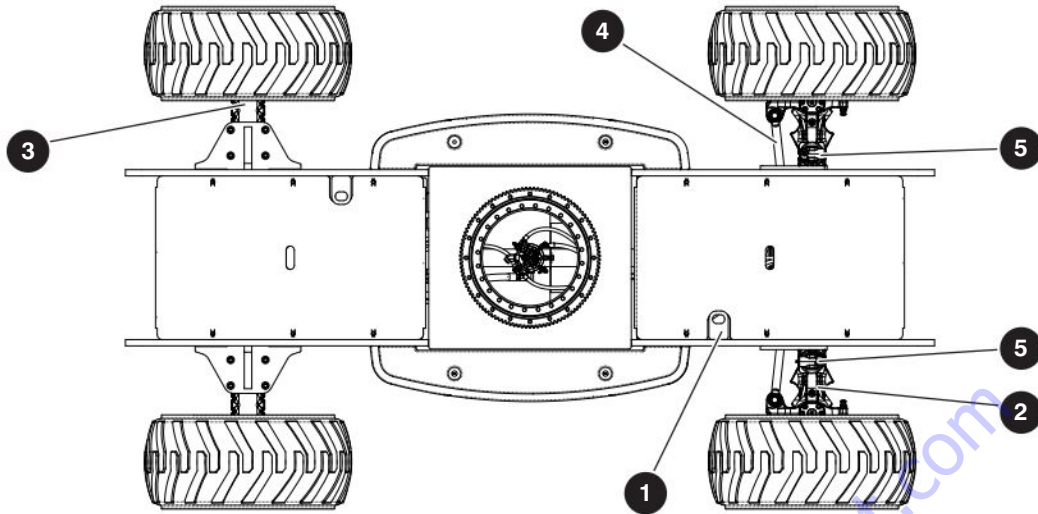

4.2-7 Base

Do the inspection that follows:

1 Turret transportation lock

- Make sure the turret transportation lock is unlocked.
- Make sure there are no loose or missing parts.
- Make sure there is no visible damage.

Axles

- Make sure the front 2 and rear 3 drive axles are correctly attached.
- Make sure there are no loose or missing parts.
- Make sure all the fittings and hose connections are tight.
- Make sure there is no sign of hydraulic leakage.

4 Tie rod

- Make sure there are no loose or missing parts.
- Make sure the tie rod end studs are attached and tight.
- Make sure there is no visible damage.

5 Oscillating cylinders

- Make sure the oscillating cylinder assembly is correctly attached, and there are no visible spaces.
- Make sure there are no loose or missing parts.
- Make sure all the fittings and hose connections are tight.
- Make sure there is no sign of hydraulic leakage.

NOTE

The oscillating axle is locked when the MEWP is in the elevated travel position or at the elevated travel speed.

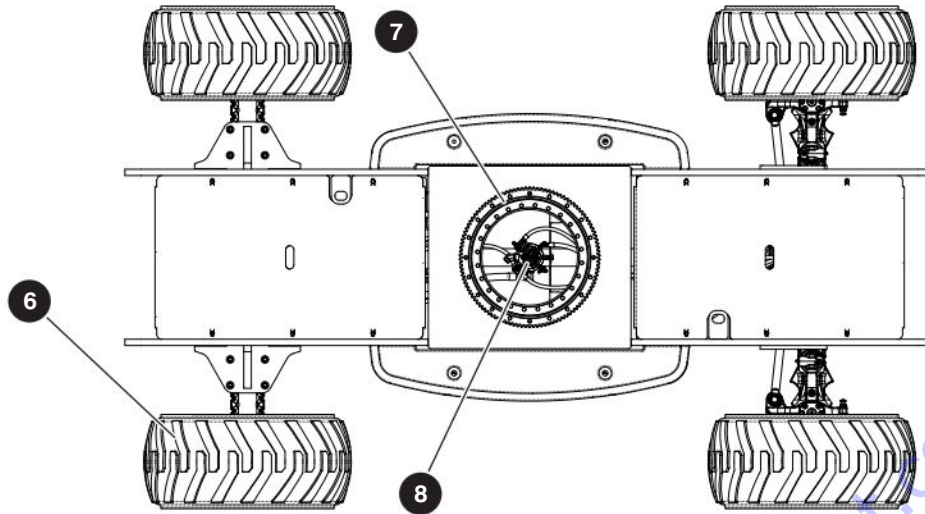

6 Wheel/Tire assembly

- Do a check on all tire treads and sidewalls for cuts, cracks, holes, and unusual wear.
- Do a check on each wheel for damage, and cracked welds.
- Do a check on each lug nut for the correct torque to make sure they are not loose.
- Make sure the wheels are correctly aligned vertically and horizontally.
- Make sure there are no loose or missing parts.
- Make sure there is no visible damage.

7 Turret rotation gear

- Make sure there are no loose or missing parts.
- Make sure there is no visible damage.

8 Rotary manifold

- Make sure all hoses are correctly tightened and there is no sign of hydraulic leakage.

Refer to [Section 7.6](#) for wheel/tire specifications.

⚠ WARNING

Do not use tires other than the tires that Skyjack specifies for this MEWP. Do not mix different types of tires or use tires that are not in good condition. Only replace the tires with the same types that are approved by Skyjack. The use of other tires can make the MEWP less stable. If you do not obey, there is a risk of death or serious injury.

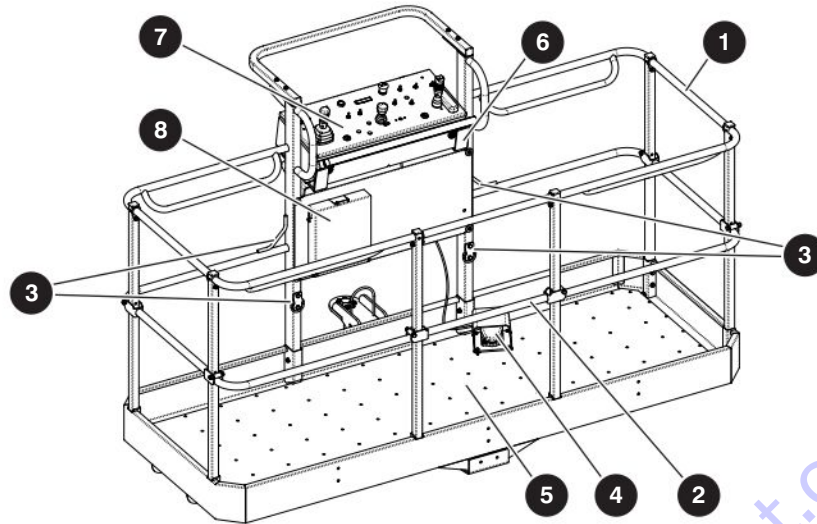

4.2-8 Platform assembly

Do the inspection that follows in sequence:

⚠ WARNING

Fall hazard. Use the three points of contact principle when you enter or exit the platform. If you do not obey, there is a risk of death or serious injury.

1. Enter the platform and close the gate or drop bar.
2. Close the gate.

1 Platform railings

- Make sure there are no loose or missing parts, and there is no visible damage.
- Make sure the fasteners are correctly installed.
- Make sure the platform railings **1** are in the correct position.
- Make sure the gates or drop bars **2** are in good condition and operate correctly.

3 Fall-protection anchorages

- Make sure that the fall-protection anchorages are correctly installed.
- Make sure there is no visible damage.

4 Footswitch

- Make sure the footswitch is in good working order and has not been tampered with, disabled or blocked.

5 MEWP floor

- Make sure the MEWP floor is solid and there is no visible damage.

6 AC power socket

- Make sure that the socket is free of dirt or blockages.

7 Platform control console

- Make sure all switches and controllers are in the neutral position.
- Make sure there are no loose or missing parts, and there is no visible damage.

8 Manual storage box

- Make sure that the operation manual and other important documents are in the manual storage box.
- Make sure that the documents are in good condition, and you can read them.
- Always put the manuals and other documents back in the storage box after use.

3. Exit the platform.

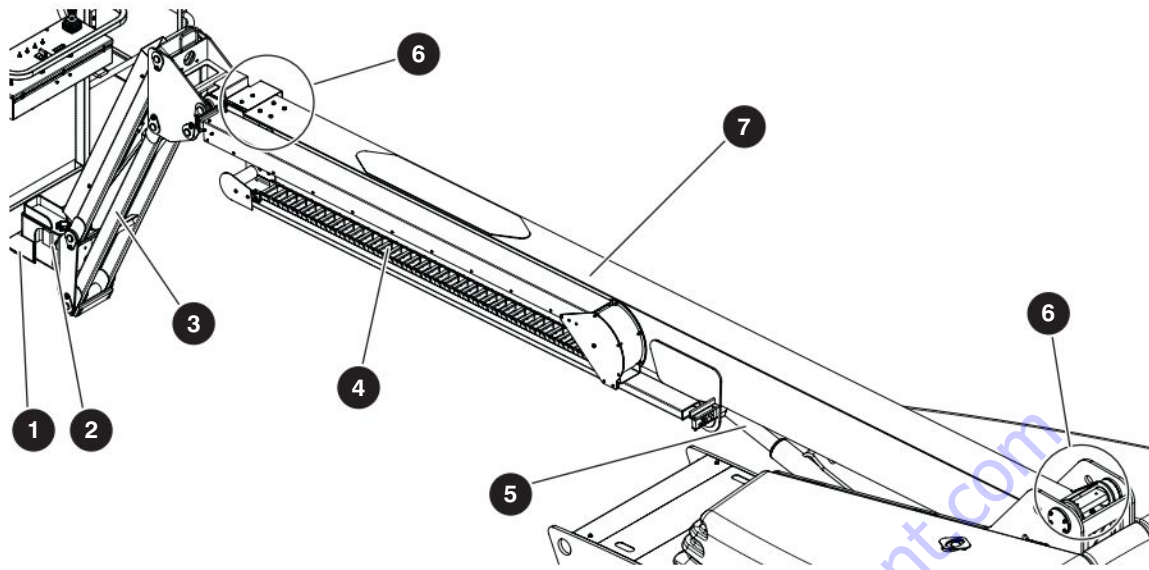

4.2-9 Boom assembly

Do the inspection that follows, and make sure:

1 Load cell

- There are no loose or missing parts, and there is no visible damage.
- All fasteners are correctly tightened.
- All cables are in good condition and not loose.
- There is no debris between the platform and the boom adaptor.

2 Rotary actuator

- There are no loose or missing parts, and there is no visible damage.
- All fasteners are correctly tightened.
- All hoses are correctly tightened and there is no sign of hydraulic leakage.

3 Jib (if equipped)

- There are no loose or missing parts, and there is no visible damage.
- All fasteners are correctly tightened.
- All hoses are correctly tightened and there is no sign of hydraulic leakage.

4 Cable Track

- There are no loose or missing parts, and there is no visible damage.

5 Cylinders

- Make sure the cylinders are correctly installed.
- Make sure there is no indication of leaks or damage.

6 Wear pads

- All fasteners are correctly tightened.
- There are no loose or missing parts, and there is no visible damage to the wear pads.

7 Boom

- There are no loose or missing parts, and there is no visible damage.
- All fasteners are correctly tightened.
- All hoses are correctly tightened and there is no sign of hydraulic leakage.

Hoses

- All hoses are correctly tightened and there is no sign of hydraulic leakage.

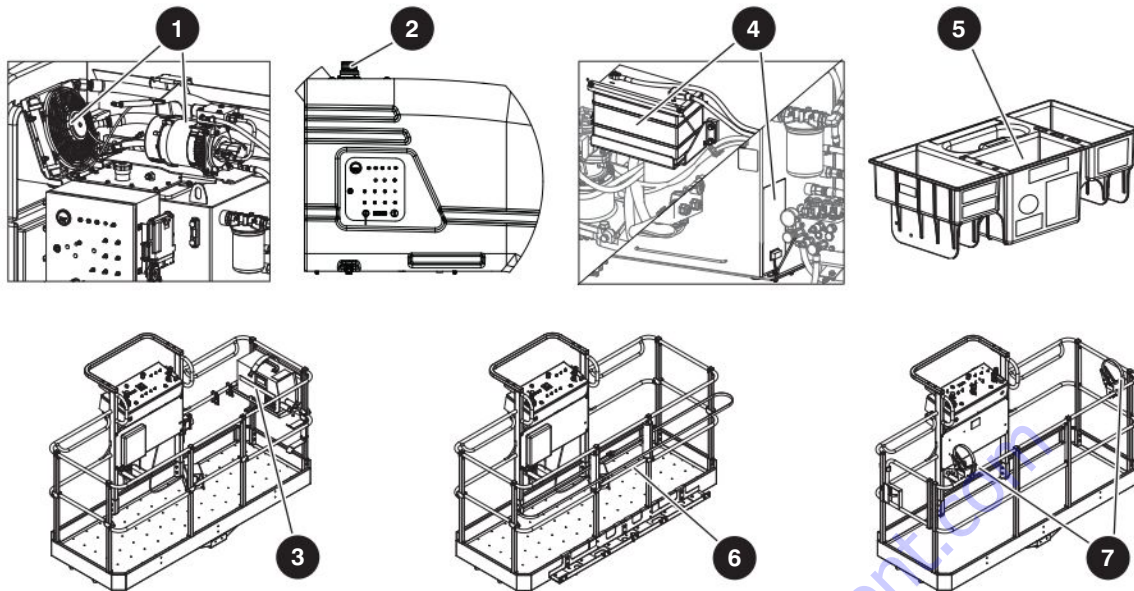

4.2-10 Optional equipment

Do the inspection that follows, and make sure:

1 Generator

- There are no loose or missing parts, and there is no visible damage.
- All hoses are correctly tightened and there is no sign of hydraulic leakage.

2 Flashing amber light

- The lamp is correctly attached, and there is no visible damage.

3 Welder

- The welder and the welder tray are correctly attached.
- There are no loose or missing parts, and there is no visible damage.
- There are no loose wires or missing fasteners.

4 Cold or arctic weather package

- The heater plugs are correctly attached with no visible damage.
- There is no sign of engine oil leakage.

5 Tool tray

- The tray is correctly attached with lock-pins, and there is no visible damage.

6 Glazier

- There are no loose or missing parts, and there is no visible damage.
- Select the derate mode on the capacity derate switch, and check that the capacity derate light turns on.

7 Pipe rack

- There are no loose or missing parts, and there is no visible damage.
- Select the derate mode on the capacity derate switch, and check that the capacity derate light turns on.

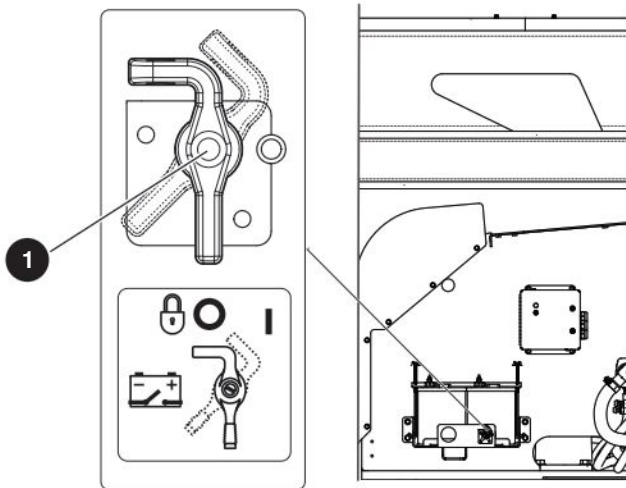

4.3 Function tests

Do the function tests in sequence.

WARNING

Do not operate a MEWP that does not function correctly. Lock and tag the MEWP, and remove it for servicing. Only a qualified service technician must repair the MEWP. If you do not obey, there is a risk of death or serious injury.

NOTE

To do these function tests, make sure there is sufficient space to fully raise and extend the boom.

NOTE

The motion alarm makes a sound while you operate a boom or drive function.

Be sure to read [Section 5](#) before you do the function tests.

4.3-1 Do a test of the main power disconnect switch

1. Turn the **main power disconnect** ❶ switch to the off position.
 - **Result:** The MEWP functions do not operate.
2. Turn the **main power disconnect** switch to the on position.

NOTE

Close all cowlings before you continue on to the next test.

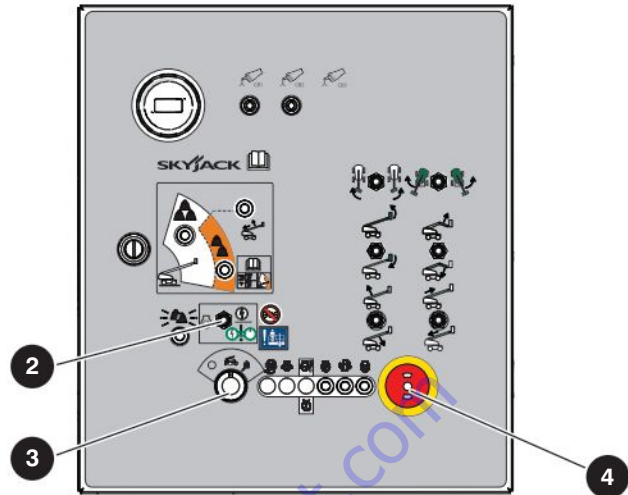

4.3-2 Do a test of the base keyswitch and the emergency-stop button and light

1. On the platform control console, pull the **emergency-stop** button.
2. For dual fuel engines, move the **fuel switch** to the gasoline position or liquid propane gas position to select the fuel type.
3. On the base control console, pull the **emergency-stop** button ❷.
4. Turn the **off/base/platform key switch** ❸ to the base position.
5. Select the **start position** from the **start/function enable/emergency power** switch ❹ to start the engine.
6. Push the **emergency-stop** button ❸ and try to operate a MEWP function.
 - **Result:** The engine stops, and the MEWP functions do not operate.
7. Pull the **emergency-stop** button and restart the engine.
 - **Result:** The emergency-stop light continuously illuminates.

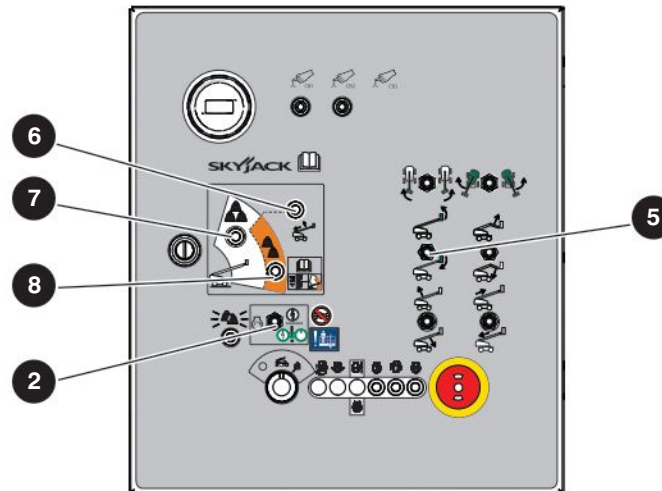

4.3-3 Do a test of the start/function enable/emergency power switch and all the boom and platform functions

WARNING

Look for overhead obstructions or other possible hazards around the MEWP when you raise the platform. Do not lower the platform unless the area below is clear of personnel and obstructions. If you do not obey, there is a risk of death or serious injury.

1. Do not hold the **start/function enable/emergency power** switch (2) in the function enable position. Try to operate each boom and platform switch.
 - **Result:** All the boom and platform functions do not operate.
2. Hold the **start/function enable/emergency power** switch in the function enable position and operate each boom and platform function.
 - **Result:** The engine speed increases from idle to intermediate. All the boom and platform functions operate as selected.

4.3-4 Do a test of the platform self-leveling

1. Lower the boom to the stowed position.
2. Adjust the platform to a level position with the **platform-leveling** switch (5), which controls the tilt up or tilt down function of the platform.
3. Fully raise the main boom.
 - **Result:** The platform stays level at all times and the lift speed decreases before the boom is at full height.
4. Fully lower the main boom.
 - **Result:** The platform stays level at all times.

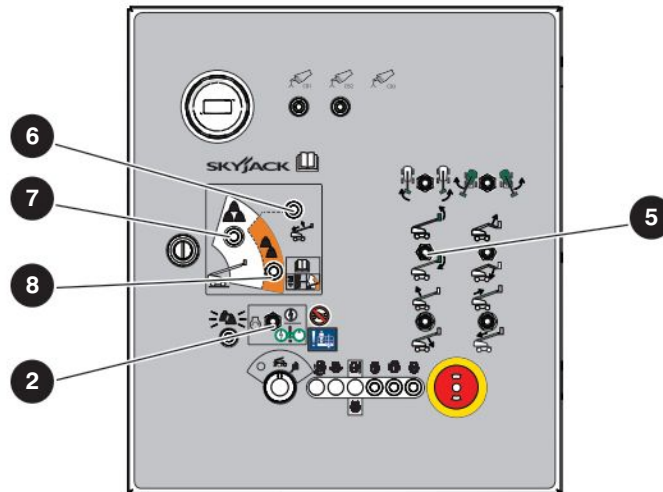

4.3-5 Do a test of the platform capacity zone indicator lights

1. Push the **emergency-stop** button.
2. Pull the **emergency-stop** button.
 - **Result:** The **capacity zone border light** ⑥ illuminates for 1 second and then goes off. The **high-capacity zone indicator light** ⑦ illuminates.
3. Extend the boom until the high-capacity zone indicator light goes off.
 - **Result:** The **low-capacity zone indicator light** ⑧ illuminates.
4. While the boom is extended, make sure there are no visible cracks in the welds or structure, and there are no signs of deformation.
5. Fully retract and lower the boom.

4.3-6 Do a test of the emergency power unit

1. On the base control console, push the **emergency-stop** button to turn the engine off.
2. On the platform control console, push the **emergency-stop** button.

CAUTION

Do not operate more than one function at a time when you use the emergency power. If you do so, it will overload the 12 volt emergency pump motor.

NOTE

To conserve the battery power, do a test of each function through part of a cycle.

3. On the base control console, pull the **emergency-stop** button.
4. Turn the **off/base/platform key** switch to the base position.
5. Select the emergency power position from the **start/function enable/emergency power** switch ② and operate each boom function.
 - **Result:** All selected functions operate.

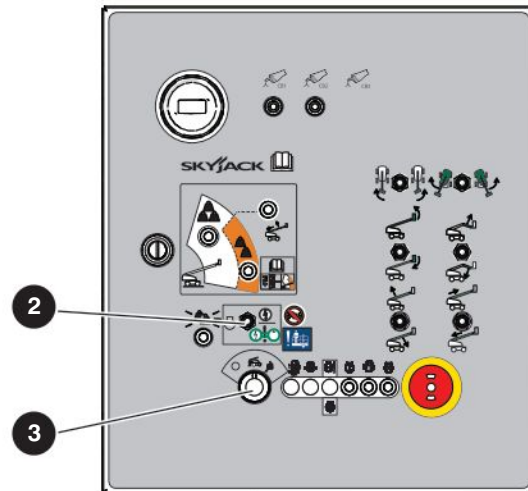

4.3-7 Do a test of the off/base/platform switch

1. Make sure the emergency-stop buttons at the base and platform are pulled out.
2. Start the engine.
3. On the base control console, turn the **off/base/platform key switch** ③ to the off position.
 - **Result:** The engine stops and the MEWP functions do not operate.
4. On the base control console, turn the **off/base/platform key switch** to the platform position.

WARNING

Fall hazard. Use the three points of contact principle when you enter or exit the platform. If you do not obey, there is a risk of death or serious injury.

5. Enter the platform and close the gate or drop bar.
6. Select the start position from the **engine start/on/off switch** until the engine starts.
7. Exit the platform.
8. On the base control console, try to operate each boom and platform switch while you hold the **start/function enable/emergency power switch** in the function enable position.
 - **Result:** All the boom and platform functions do not operate.
9. Push the **emergency-stop** button to turn the engine off.
10. Pull the **emergency-stop** button.

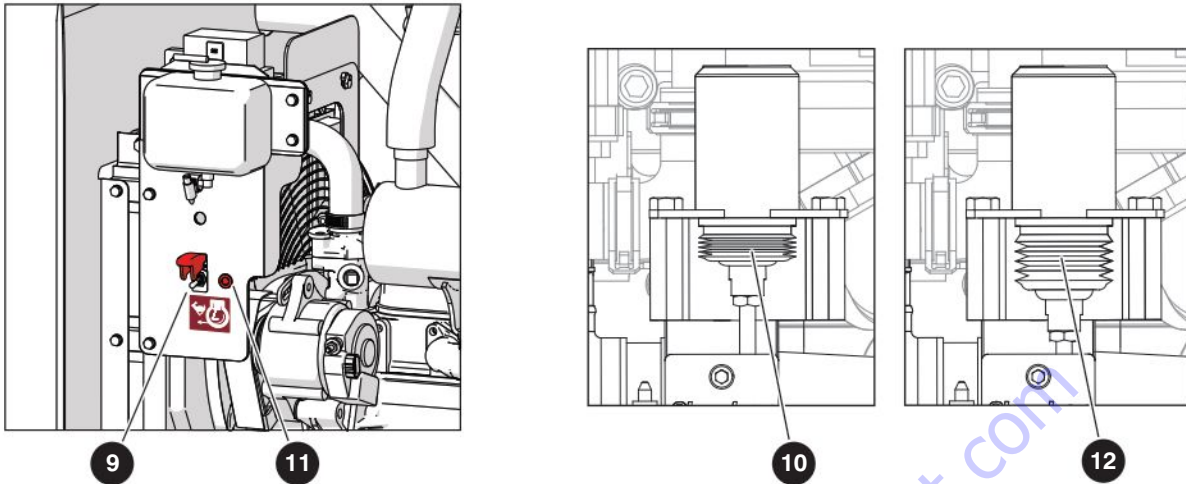

4.3-8 Do a test of the positive air shut-off switch (optional equipment)

CAUTION

Do not do this function test while the engine is on.

1. Open the engine compartment cover.
2. Lift the switch guard for the positive air shut-off on the engine control console.
3. Move the **positive air shut-off** switch **9** to the on position to engage the shut-off valve **11**.
4. Move the **positive air shut-off** switch to the off position to disengage the shut-off valve **12**. The **light** **10** continuously illuminates.
 - **Result:** The shut-off valve disengages after 20 seconds.
5. Make sure the **positive air shut-off** switch is put back to the off position, and that the switch guard is down. Close the engine compartment cowling.

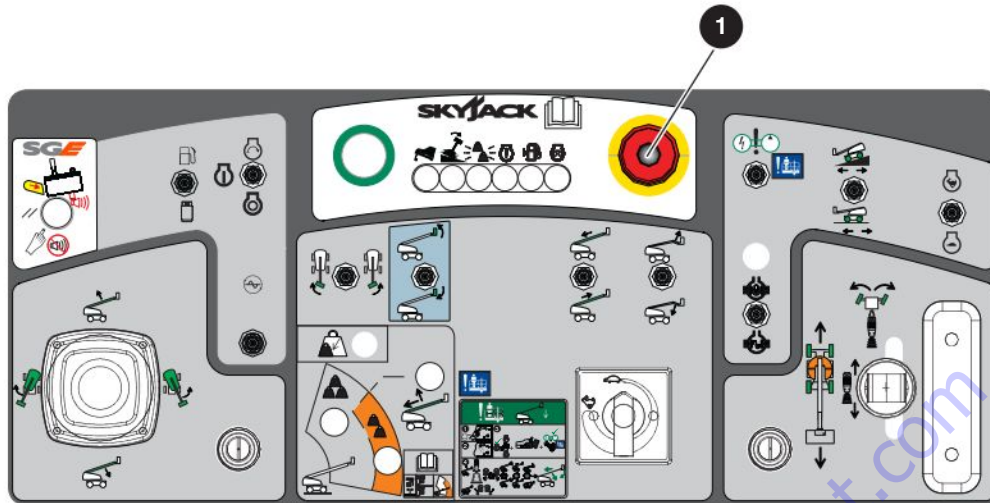

4.3-9 Do a test of the emergency-stop button and emergency-stop light on the platform

WARNING

Fall hazard. Use the three points of contact principle when you enter or exit the platform. If you do not obey, there is a risk of death or serious injury.

1. Make sure the emergency-stop buttons at the base and platform are pulled out.
2. On the base control console, turn the **off/base/platform key** switch to the platform position.
3. Enter the platform and close the gate or drop bar.

WARNING

Fall hazard. Do not operate the controls on the platform control console without the correct fall-protection attached to the designated location in the platform. If you do not obey, there is a risk of death or serious injury.

WARNING

Look for overhead obstructions or other possible hazards around the MEWP when you raise the platform. Do not lower the platform unless the area below is clear of personnel and obstructions. If you do not obey, there is a risk of death or serious injury.

4. Make sure the engine is on.
5. Push the **emergency-stop** button **1** and try to operate a MEWP function.
 - **Result:** The engine stops and the MEWP functions do not operate.
6. Pull the **emergency-stop** button and restart the engine.
 - **Result:** The emergency-stop light continuously illuminates.

4.3-10 Do a test of the load sensing module self-check

1. Push the **emergency-stop** button.
2. Pull the **emergency-stop** button.
 - **Result:** After four seconds, the load zone lights and the alarm pulse. This shows that the system is in operation, and there are no faults.

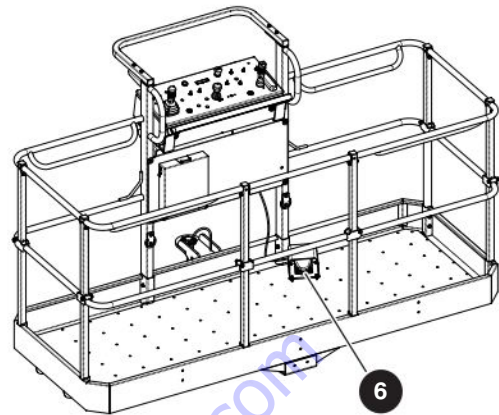
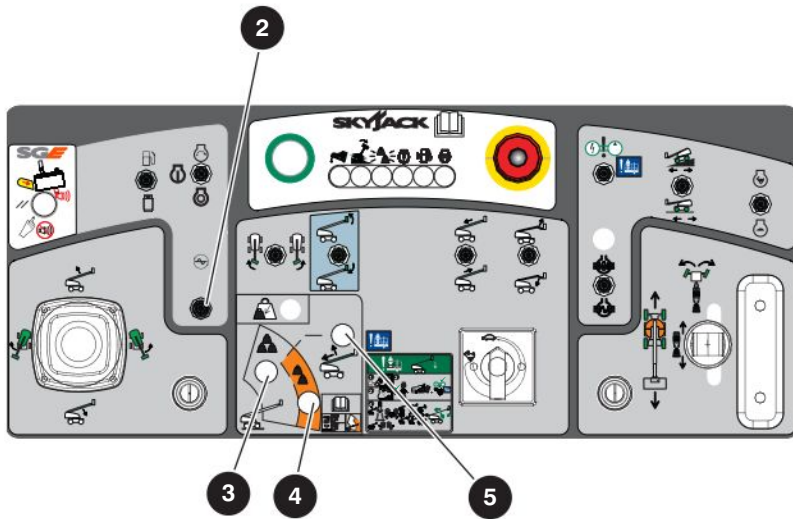

4.3-11 Do a test of the footswitch and all the boom and platform functions

1. Make sure the **emergency-stop** button is pulled out.
2. Make sure the **engine start/on/off** switch is in the on position.
3. Do not start the engine.
4. Move the **generator** switch (2) (optional equipment) to the off position.
5. Press and hold the **footswitch** (6) and select the start position from the **engine start/on/off** switch to try to start the engine.
 - **Result:** The engine does not start.
6. Do not press the **footswitch**, and try to start the engine.
 - **Result:** The engine starts.
7. Do not press the **footswitch**, and do a test of each boom and platform function with the engine on.
 - **Result:** The MEWP functions do not operate.

NOTE

A 7-second anti-tiedown feature prevents the footswitch operation when the operator presses it for 7 seconds without the activation of a function.

8. Press and hold the **footswitch**, and do a test of all the boom and platform functions with the engine on.
 - **Result:** All MEWP functions operate.

4.3-12 Do a test of the platform capacity zone indicator lights

1. Make sure the boom is in the stowed position.
2. Push the **emergency-stop** button.
3. Pull the **emergency-stop** button.
 - **Result:** The **capacity zone border light** (5) illuminates for 1 second and then goes off. The **high-capacity zone indicator light** (3) illuminates.
4. Start the engine.
5. Press and hold the **footswitch** and extend the boom until the high-capacity zone indicator light goes off.
 - **Result:** The **low-capacity zone indicator light** (4) illuminates.
6. Press and hold the **footswitch** and fully retract and lower the boom.

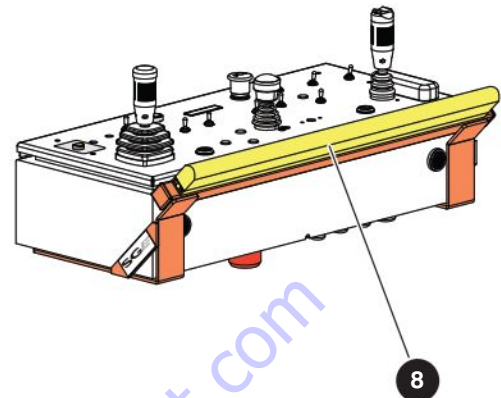
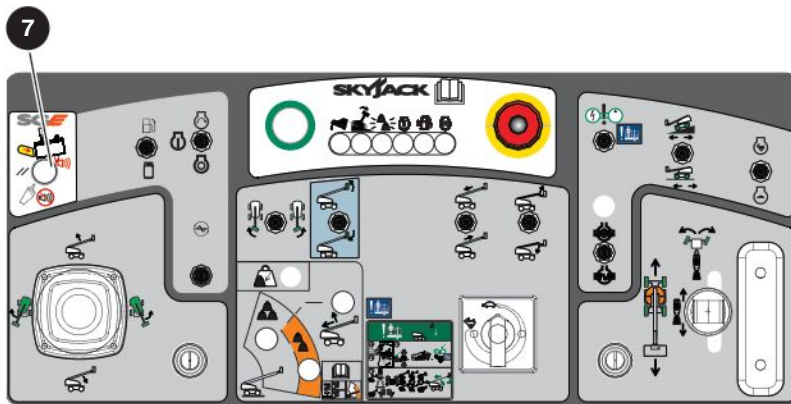

4.3-13 Do a test of the secondary guarding electrical (SGE)

1. Press the **sensor bar** **8** for less than 1 second and then release it.
 - **Result:** The audible/visual alarm goes on while the bar is pressed and goes off after it is released. The reset button illuminates when the bar is pressed, and goes off when the bar is released.
2. Press the **sensor bar** for more than 1 second and then release it.
 - **Result:** The audible/visual alarm goes on immediately and stays on after the bar is released. The reset button illuminates.
3. Press the **reset** **7** button.
 - **Result:** The audible/visual alarm and reset button light go off.
4. Start the engine.
5. Press the **sensor bar** for less than 1 second and then release it.
 - **Result:** The audible/visual alarm goes on while the bar is pressed and goes off after it is released. The reset button illuminates when the bar is pressed, and goes off when the bar is released.
6. Press the **sensor bar** for more than 1 second and then release it.
 - **Result:** The audible/visual alarm goes on immediately and stays on after the bar is released. The engine stops after 1 second. The reset button illuminates.
7. Press the **reset** button.
 - **Result:** The audible/visual alarm and reset button light go off.
8. Start the engine.
9. Operate a drive function in the high torque mode.
10. Press the **sensor bar** for less than 1 second and then release it.
 - **Result:** The function will stop while the bar is pressed and the function will continue when the bar is released. The audible/visual alarm goes on while the bar is pressed and goes off after it is released. The reset button illuminates when the bar is pressed, and goes off when the bar is released.
11. Press the **sensor bar** for more than 1 second and then release.
 - **Result:** The function will stop and the audible/visual alarm goes on immediately and stays on after the bar is released. The engine stops after 1 second. The reset button illuminates.
12. Start the engine.
13. Operate a platform function (i.e., lift, extend, or rotate).
14. Press the **sensor bar** for less than 1 second and then release it.
 - **Result:** The function will stop while the bar is pressed and the function will continue when the bar is released. The audible/visual alarm goes on while the bar is pressed and goes off after it is released. The reset button illuminates when the bar is pressed and goes off when the bar is released.

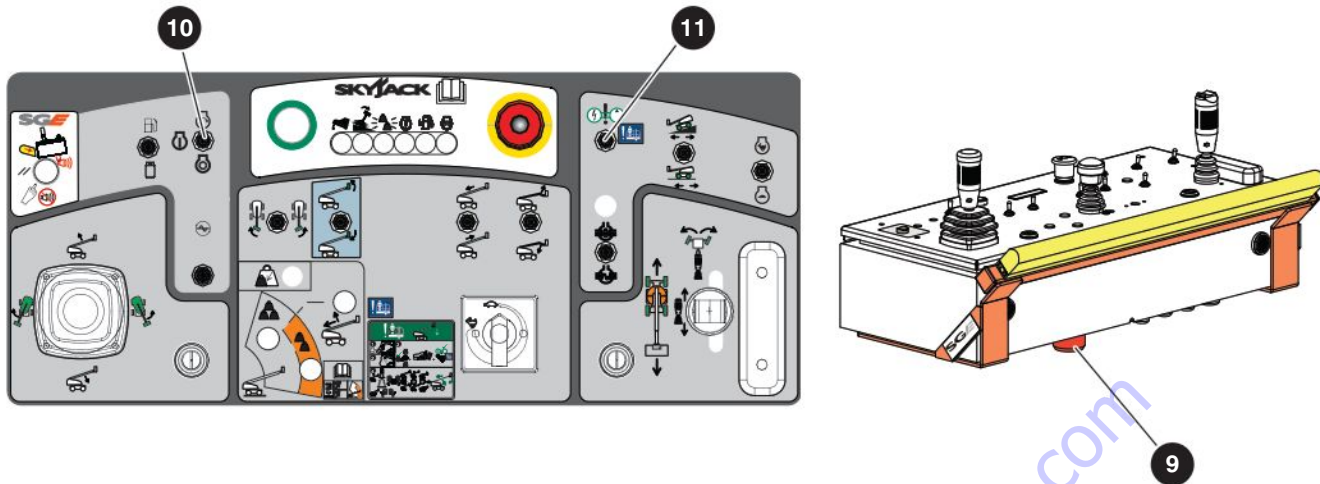

15. Press the **sensor bar** for more than 1 second and then release it.
 - **Result:** The function will stop and the audible/visual alarm goes on immediately and stays on after the bar is released. The engine stops after 1 second. The reset button illuminates.
16. While the **audible/visual alarm** ⑨ is on, make sure the LED strobe light is also on.

4.3-14 Do a test of the engine start/on/off switch

1. Make sure the engine is on.
2. Select the off position from the **engine start/on/off** ⑩ switch.
 - **Result:** The engine stops and the platform control console is disabled.
3. Select the on position from the **engine start/on/off** switch.
 - **Result:** The platform control console is enabled.
4. Select the start position from the **engine start/on/off** switch to start the engine.

4.3-15 Do a test of the emergency power unit

⚠ CAUTION

Do not operate more than one function at a time when you use the emergency power. If you do so, it will overload the 12 volt emergency pump motor.

NOTE

To conserve the battery power, do a test of each function through part of a cycle.

1. Push the **emergency-stop** button to turn the engine off.
2. Pull the **emergency-stop** button.
3. Select the on position from the **engine start/on/off** switch.
4. Press and hold the **footswitch**.
5. Select the **emergency-power unit** switch ⑪ and operate each function control handle or switch.
 - **Result:** All the boom functions operate. The drive and steer functions do not operate.

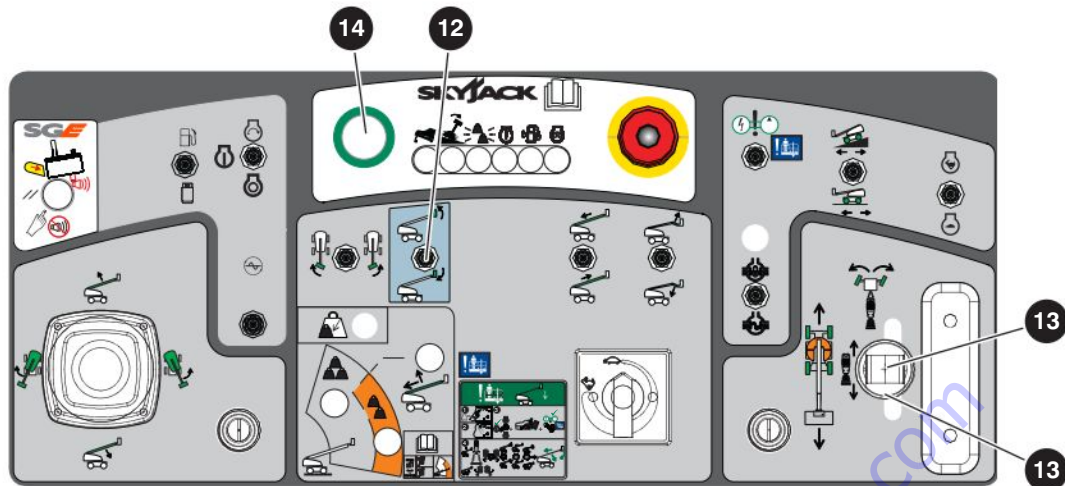

4.3-16 Do a test of the manual platform-leveling

1. Start the engine.
2. Press and hold the **footswitch**.
3. On the **platform-leveling override** switch **12** select the up position to tilt the platform up or the down position to tilt the platform down.
 - **Result:** The platform tilts up or down.

4.3-17 Do a test of the steer function

1. Pull the **emergency-stop** button.
2. Select the start position from the **engine start/on/off** switch to start the engine.
3. Press and hold the **footswitch**.
4. Press the **steering rocker** switch **13** on top of the drive/steer controller to steer left and right.
 - **Result:** The steer wheels turn left and right.
5. Put the wheels in the parallel position before you continue with the next test.

4.3-18 Do a test of the drive function

1. Make sure the path of intended motion is clear.
2. Make sure the boom is in the stowed position and the fly boom is fully retracted.
3. Press and hold the **footswitch**.
4. Slowly push the **drive/steer controller handle** **13** until the MEWP starts to move. Then, release the handle, so that it goes back to the center position.
 - **Result:** The MEWP moves in the forward direction and then stops.

5. Slowly pull the **drive/steer controller handle** until the MEWP starts to move. Then, release the handle, so that it goes back to the center position.
 - **Result:** The MEWP moves in the opposite direction and then stops.

4.3-19 Do a test of the brakes

IMPORTANT

The brakes engage instantly when you release the footswitch. This causes the MEWP to stop immediately.

1. Make sure the path of intended motion is clear.
2. Make sure the boom is in the stowed position.
3. Start the engine.
4. Move the MEWP to a firm, level surface to make sure there is the same traction on the left and right sides.
5. Press and hold the **footswitch** and drive the MEWP forward and then rearward at full speed.
6. Remove your foot from the **footswitch**.
 - **Result:** The MEWP comes to a sudden stop. Do not operate the MEWP if it does not stop immediately, or it pulls to one side while it stops. A service technician must do a check on the brake adjustments.

4.3-20 Do a test of the horn

1. Push the **horn** button **14**.
 - **Result:** The horn makes a sound.

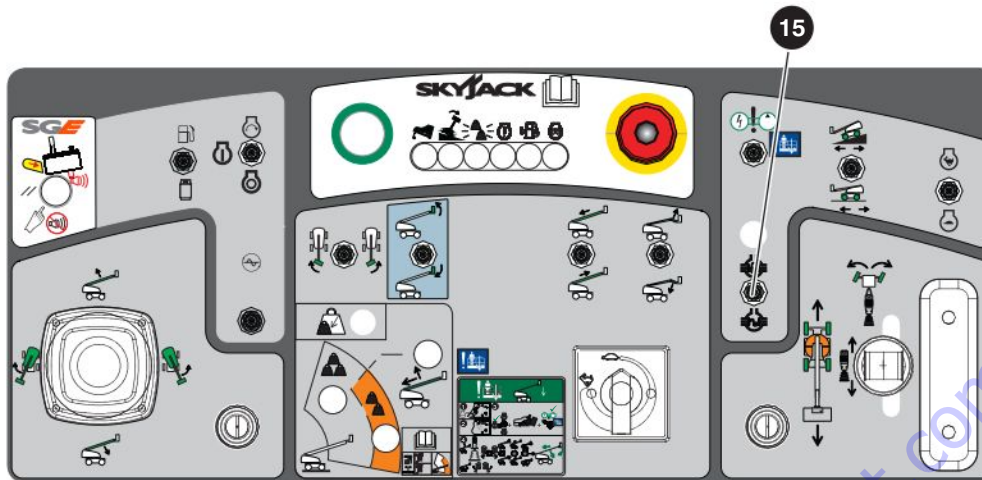

4.3-21 Do a test of the elevated travel speed

⚠ WARNING

Look for overhead obstructions or other possible hazards around the MEWP when you raise the platform. Do not lower the platform unless the area below is clear of personnel and obstructions. If you do not obey, there is a risk of death or serious injury.

1. Make sure the path of intended motion is clear.
2. Press and hold the **footswitch**.
3. Raise the main boom until it is at a height of approximately 4 m (14 ft).
4. Slowly move the **drive/steer controller handle** to drive forward and then rearward.
 - **Result:** The MEWP drives slower than when it was in the lowered travel position.
5. Lower the main boom to the stowed position.
6. Extend the fly boom approximately 30 cm (12 in).
7. Slowly move the **drive/steer controller handle** to drive forward and then rearward.
 - **Result:** The MEWP drives slower than when it was in the lowered travel position.
8. Fully retract the fly boom.

4.3-22 Do a test of the differential lock switch

⚠ WARNING

Before you engage the differential lock, make sure the drive/steer controller handle is in the neutral position.

1. Push the **differential lock switch** 15 and then release it.
 - **Result:** The differential light goes on. The differential lock engages.
2. Pull the **differential lock** switch and then release it.
 - **Result:** The differential light goes off.

The differential lock disengages when the drive torque is released. Refer to [Section 5.20](#).

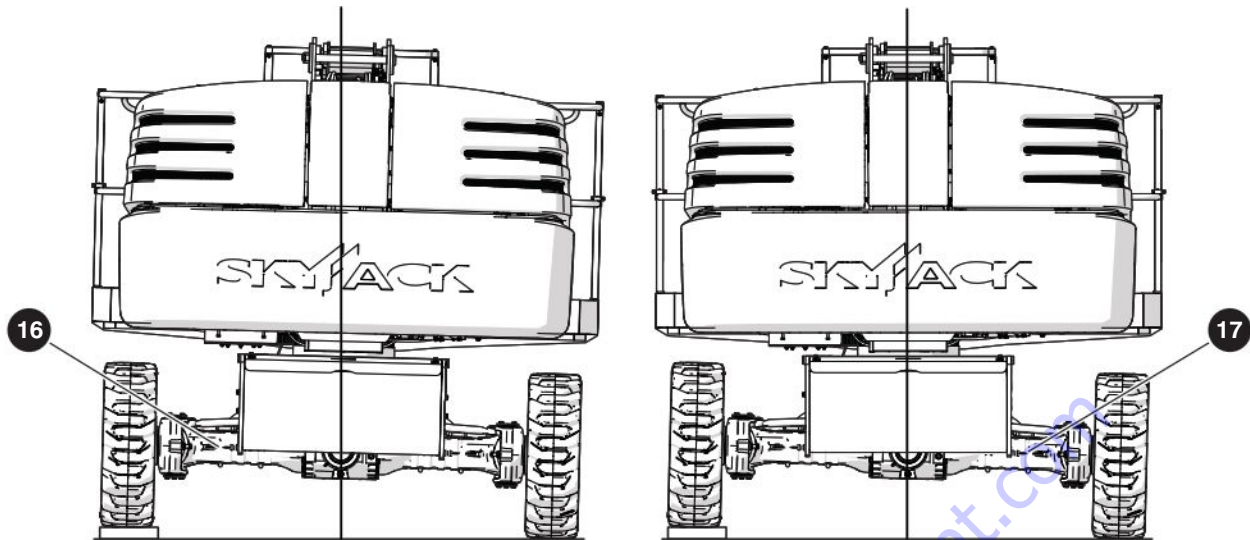

4.3-23 Do a test of the oscillating cylinders

⚠ WARNING

Fall hazard. Do not operate the controls on the platform control console without the correct fall-protection attached to the designated location in the platform. If you do not obey, there is a risk of death or serious injury.

1. Make sure the MEWP is on a firm, level surface.
2. Extend the boom 30 cm (12 in).
 - **Result:** The steer axle oscillation locks 16.
3. Drive one of the steer tires onto a 15 cm (6 in) block or curb.
 - **Result:** The MEWP chassis tilts.
4. Retract the boom.
 - **Result:** The steer axle oscillation unlocks 17. The MEWP chassis is now level.

4.4 Operator's checklist (page 1 of 2)



Telescopic and Articulating Booms Daily Operator's Checklist

Serial Number: _____
 Model: _____
 Hourmeter Reading: _____
 Date: _____
 Time: _____

Operator's Name
(Printed): _____
 Operator's Signature: _____

Each item shall be inspected using the appropriate section of the Skyjack operating manual. As each item is inspected, check or complete the appropriate box.

P PASS N/A NOT APPLICABLE

Add a comment if the item does not pass inspection.

	P	N/A	Comment (if item does not pass inspection)
Visual and Daily Maintenance Inspections			
Labels - Do an inspection for damaged, or missing labels			
Electrical - Do an inspection for loose, damaged, or missing components			
Limit switches - Do an inspection for loose, damaged, or missing components			
Hydraulic - Do an inspection for loose, damaged, or missing components			
Engine compartment - Do an inspection for loose, damaged, or missing components			
Main power disconnect switch			
Batteries			
Hydraulic pump and motor			
Swing drive			
Muffler and exhaust			
Engine control console			
Engine air intake filter			
Engine and engine pivot tray			
Engine oil level			
Control compartment - Do an inspection for leaks and loose, damaged, or missing components			
Base control console			
Hydraulic tank			
Hydraulic oil level			
Hydraulic return filter			
High-pressure filter			
Manifolds			
Emergency-power unit			
Fuel tank			
Base - Do an inspection for loose, damaged, or missing components			
Turret transportation lock			
Axles			
Tie rod			
Oscillating cylinders			
Wheel/tire assembly			
Turret rotation gear			
Rotary manifold			
Platform assembly - Do an inspection for loose, damaged, or missing components			
Platform railings			
Fall-protection anchorages			
Footswitch			

NOTE: Make a copy of this page or go to www.skyjack.com for a copy that you can print.

Operator's checklist (page 2 of 2)

	P	N/A	Comment (if item does not pass inspection)
Visual and Daily Maintenance Inspections			
Platform assembly - Do an inspection for loose, damaged, or missing components			
MEWP floor			
AC power socket			
Platform control console			
Manual storage box			
Boom assembly - Do an inspection for loose, damaged, or missing components			
Load cell			
Rotary actuator			
Jib			
Cable track			
Cylinders			
Wear pads			
Boom			
Hoses			
Wire ropes			
Optional equipment and attachments - Do an inspection for leaks and loose, damaged, or missing components			
Function Tests			
Do a test of the main power disconnect switch			
Base control console			
Do a test of the emergency-stop button and emergency-stop light on the base			
Do a test of the start/function enable/emergency power switch and all the boom and platform functions			
Do a test of the platform self-leveling			
Do a test of the platform capacity zone indicator lights			
Do a test of the emergency power unit			
Do a test of the off/base/platform switch			
Do a test of the positive-air shutoff switch			
Platform control console			
Do a test of the emergency-stop button and emergency-stop light on the platform			
Do a test of the control module and load sensing module self-check			
Do a test of the footswitch and all the boom and platform functions			
Do a test of the boom lowering cutout switch			
Do a test of the platform capacity zone indicator lights			
Do a test of the wire ropes			
Do a test of the secondary guarding electrical (SGE)			
Do a test of the engine start/on/off switch			
Do a test of the emergency power unit			
Do a test of the manual platform-leveling			
Do a test of the steer function			
Do a test of the drive function			
Do a test of the brakes			
Do a test of the horn			
Do a test of the elevated travel speed			
Do a test of the differential lock switch			
Do a test of the EcoStart			
Do a test of the oscillating cylinders			

NOTE: Make a copy of this page or go to www.skyjack.com for a copy that you can print.

Section 5 – Operation

WARNING

Do not operate this MEWP without authorization and training. If you do not obey, there is a risk of death or serious injury.

Do these tasks in sequence before MEWP operation:

1. Visual and daily maintenance inspections. Refer to [Section 4.2](#).
2. Function tests. Refer to [Section 4.3](#).
3. Worksite inspection. Refer to [Section 2.4](#).
4. If a risk assessment finds that a rescue plan is necessary, make sure you have a system of communication. The communication must be between the personnel on the platform and the selected support personnel. The selected support personnel must know how to use the base controls to lower the platform.

WARNING

Do not operate the MEWP if:

- It does not operate correctly
- It is damaged or shows worn or missing parts
- The safety devices are tampered with or disabled
- It is locked and tagged for servicing or repair
- It was modified without permission from Skyjack and the MEWP owner.

If you do not obey, there is a risk of death or serious injury.

WARNING

Do not operate the MEWP with engine power in a closed space. Only operate the MEWP with engine power in an open or well-ventilated area. If you do not obey, there is a risk of death or serious injury.

5.1 Energize the base control console

WARNING

Fall hazard. Use the three points of contact principle when you enter or exit the platform. If you do not obey, there is a risk of death or serious injury.

1. Enter the platform and close the gate or drop bar.
2. Pull the **emergency-stop** button on the platform control console.
3. For dual fuel engines, select the fuel type by moving the fuel switch to the gasoline or liquid propane gas position.
4. Exit the platform.
5. Turn the **main power disconnect** switch to the on position.
6. Turn the **off/base/platform key** switch to the **base position**.
7. Pull the **emergency-stop** button on the base control console.

WARNING

If you do not hear a beep, and the light does not come on, lock and tag the MEWP. Remove the MEWP for servicing. If you do not obey, there is a risk of death or serious injury.

8. Select the **start position** from the **start/function enable/emergency power** switch until the engine starts.

WARNING

Do not over crank the starter. If the engine does not start after you try to start it multiple times, lock and tag the MEWP. Remove the MEWP for servicing. If you do not obey, there is a risk of death or serious injury.

If your MEWP has the cold or arctic weather package option installed, refer to [Section 5.25](#) for additional information.

5.2 Rotate the platform with the base control console

1. Move and hold the **start/function enable/emergency power** switch to the **function enable position**.
2. Move the **platform rotation** switch to the left or right. Release the switch to stop.

5.3 Rotate the turret with the base control console

WARNING

Before you rotate the turret, make sure there are no personnel or obstructions in the path of rotation, which includes blind spots. If you do not obey, there is a risk of death or serious injury.

1. Move and hold the **start/function enable/emergency power** switch to the **function enable position**.
2. Move the **turret rotation** switch to the left or right to rotate the turret clockwise or counterclockwise. Release the switch to stop.

NOTE

The turret can be rotated 360 degrees continuously.

5.4 Move the jib up and down with the base control console

1. Move and hold the **start/function enable/emergency power** switch to the **function enable position**.
2. Move the **jib up/down** switch to the up or down position. Release the switch to stop.

5.5 Raise or lower the main boom with the base control console

IMPORTANT

The maximum platform capacity changes with the boom position. The indicator lights on the base and platform control consoles show if the platform is in the high or low capacity zone.

1. Move and hold the **start/function enable/emergency power** switch to the function enable position.
2. Move the **main boom raise/lower** switch to the raise or lower position. Release the switch to stop.

5.6 Extend or retract the boom with the base control console

IMPORTANT

The platform capacity changes with the boom position and/or capacity derate switch position. The indicator lights on the base and platform control consoles show if the platform is in the high or low capacity zone.

1. Move and hold the **start/function enable/emergency power** switch to the **function enable position**.
2. Move the **boom extend/retract** switch to the extend or retract position. Release the switch to stop.

5.7 Make the platform level with the base control console

IMPORTANT

The platform capacity changes with the boom position and/or capacity derate switch position. The indicator lights on the base and platform control consoles show if the platform is in the high or low capacity zone.

1. Move and hold the **start/function enable/emergency power** switch to the **function enable** position.
2. Move the **platform-leveling override** switch to the up or down position. Release the switch to stop.

5.8 Operate with the emergency power switch at the base control console

This switch enables all of the functions, with the exception of drive, if there is an engine malfunction. Refer to [Section 6.1](#) for the emergency-lowering procedure.

5.9 Energize the platform control console

1. Turn the **off/base/platform key** switch to the platform position.

WARNING

Fall hazard. Use the three points of contact principle when you enter or exit the platform. If you do not obey, there is a risk of death or serious injury.

WARNING

Fall hazard. Do not operate the controls on the platform control console without the correct fall-protection attached to the designated location in the platform. If you do not obey, there is a risk of death or serious injury.

2. Enter the platform and close the gate or drop bar.
3. Attach the body-harness lanyards of each occupant to the fall-protection anchorage points. The fall-protection anchorage points are rated for one person per anchorage.
4. Pull the **emergency-stop** button on the platform control console.
5. Select the **start position** from the **engine start/on/off** switch until the engine starts.

IMPORTANT

The platform capacity changes with the boom position and/or capacity derate switch position. The indicator lights on the base and platform control consoles show if the platform is in the high or low capacity zone.

WARNING

Do not over crank the starter. If the engine does not start after you try to start it multiple times, lock and tag the MEWP. Remove the MEWP for servicing. If you do not obey, there is a risk of death or serious injury.

NOTE

The engine will not start if you press the footswitch.

6. Move the throttle switch to the low or high position.

WARNING

Do not drive or steer the MEWP when the platform position does not give you a clear view of the base. Cordon-off your area of operation from other personnel or equipment. If you do not obey, there is a risk of death or serious injury.

5.10 Drive forward or rearward

NOTE

The drive function operates in relation to the general orientation of the turret counterweight on the chassis (i.e., when the controller handle is forward, the counterweight faces forward). Thus, the MEWP will move in the general direction of the controller handle movement.

1. Press and hold the **footswitch**.
2. Move the **drive/steer controller handle** forward or rearward to drive at and in the necessary speed and direction.
3. Move the **drive/steer controller handle** to the neutral position to stop. Release the **footswitch**.

CAUTION

When you drive on a slope:

- The torque switch must be in the high torque position.
- Do not exceed the MEWP gradeability specified in [Section 7.4](#).
- Make sure the fuel level is above half to prevent a possible stall condition.

5.11 Steer

1. Press and hold the **footswitch**.
2. Push the **steering rocker** switch on top of the drive/steer **controller handle** in one of the two directions to steer. Release the switch to stop.

NOTE

The drive and steer functions can be active at the same time.

5.12 Move the jib up and down with the platform control console

1. Press and hold the **footswitch**.
2. Move the **jib up/down** switch to the up or down position. Release the switch to stop.

5.13 Extend or retract the boom with the platform control console

IMPORTANT

The maximum platform capacity changes with the boom position. The indicator lights on the base and platform control consoles show if the platform is in the high or low capacity zone.

1. Press and hold the **footswitch**.
2. Move the **boom extend/retract** switch to the extend or retract position. Release the switch to stop.

5.14 Make the platform level with the platform control console

1. Press and hold the **footswitch**.
2. Move the **platform-leveling override** switch to the up or down position. Release the switch to stop.

5.15 Rotate the platform with the platform control console

1. Press and hold the **footswitch**.
2. Move the **platform rotation** switch to the left or right. Release the switch to stop.

5.16 Raise or lower the main boom with the platform control console

IMPORTANT

The maximum platform capacity changes with the boom position. The indicator lights on the base and platform control consoles show if the platform is in the high or low capacity zone.

1. Press and hold the **footswitch**.
2. Move and hold the **boom/turret controller handle** forward or rearward to raise or lower the main boom.
3. Move the **boom/turret controller handle** to the neutral central position to stop. Release the **footswitch**.

5.17 Operate the horn

1. Push the **horn** button to make a sound. Release the button to stop.

5.18 Rotate the turret with the platform control console

WARNING

Before you rotate the turret, make sure there are no personnel or obstructions in the path of rotation, which includes blind spots. If you do not obey, there is a risk of death or serious injury.

1. Press and hold the **footswitch**.
2. Move and hold the **boom/turret controller handle** to the left or right to rotate the turret clockwise or counterclockwise.
3. Move the **boom/turret controller handle** to the neutral central position to stop. Release the **footswitch**.

NOTE

The turret can be rotated 360 degrees continuously.

5.19 Operate with the emergency power switch at the platform control console

This switch enables all of the functions, with the exception of drive, if there is an engine malfunction. Refer to [Section 6.1](#) for the emergency-lowering procedure.

5.20 Engage or disengage the differential lock switch

1. Move the **differential lock** switch forward and release it to lock or unlock the differential.

5.21 MEWP shutdown

1. Select a reasonably well-protected location to park the MEWP. This location must have a firm, level surface, clear of obstructions, and traffic.
2. Fully retract the boom and lower the platform.
3. Push the **emergency-stop** button on the platform control console.
4. Exit the platform.
5. Turn the **off/base/platform key** switch to the off position and remove the key.
6. Push the **emergency-stop** button on the base control console.
7. Turn the **main power disconnect** switch to the off position.
8. If it is necessary, put a cover on the platform control console to prevent damage to the warning labels and controls in hostile environments.

5.22 Generator (optional equipment)

To start the generator:

1. Make sure the engine is on.
2. Turn the **generator** switch to the on position.

To restore normal operation:

3. Turn the **generator** switch to the off position.

5.23 Glazier Tray (optional equipment)

The glazier tray attaches to the kickplate of the platform. Refer to the glazier operation manual for the correct operation and maintenance.

1. Select the derate mode on the capacity derate switch, and check that the capacity derate light turns on.

5.24 Pipe Rack (optional equipment)

The pipe rack attaches to the upper rear railing of the platform. Refer to the pipe rack operation manual for the correct operation and maintenance.

1. Select the derate mode on the capacity derate switch, and check that the capacity derate light turns on.

5.25 Cold or arctic weather package (optional equipment)

WARNING

- Do not use heaters if the temperature is above 0°C (32°F).
- Use the correct hydraulic and engine oils (refer to [Figure 07](#)).
- If the temperature is below -7°C (20°F), run the engine at idle for a minimum of 5 minutes before you operate the MEWP.

1. Make sure the MEWP is on level ground, the boom is in the stowed position, and the hydraulic oil level is between the minimum and maximum marks on the sight gauge.
2. Find the **heater plug** ❶ in the engine compartment.
3. Connect the **heater** to a 110V / 15 A protected circuit for a minimum of 4 hours.
4. Start the engine from the base control console (refer to [Section 5.1](#)).

WARNING

Do not over crank the starter. If the engine does not start after you try to start it multiple times, lock and tag the MEWP. Remove the MEWP for servicing. If you do not obey, there is a risk of death or serious injury.

IMPORTANT

Make sure the heater is disconnected before you operate the MEWP.

NOTE

If the MEWP is to be parked for an extended period of time, remove the battery and keep it in a warm location.

NOTE

Refer to the cold weather operation chart ([Figure 07](#)) to help when you operate the MEWP in cold weather conditions.

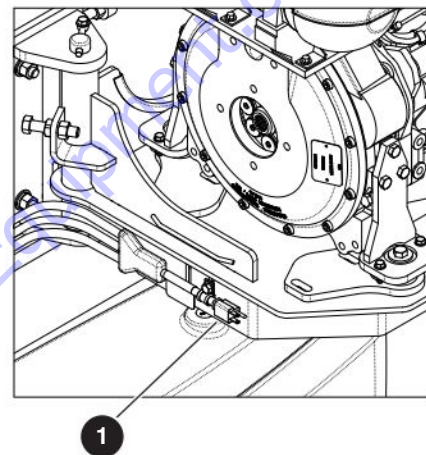

Figure 06 Heater plug

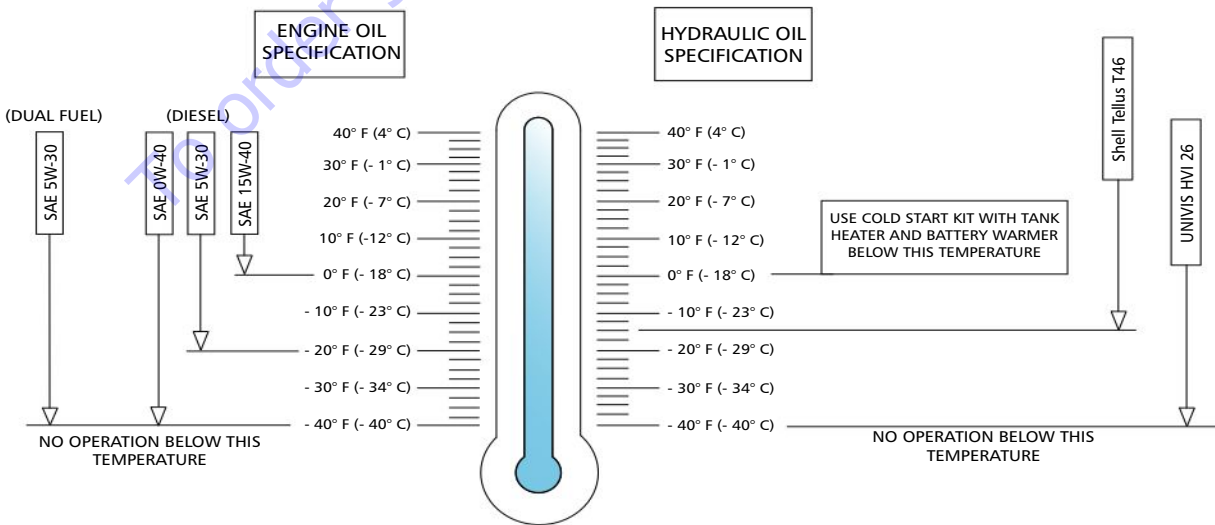

Figure 07 Cold weather operation chart

Section 6 – Additional Procedures

6.1 Use the emergency-lowering function

With the emergency-lowering system, you can lower the platform if there is a failure of the primary power.

WARNING

Look for overhead obstructions or other possible hazards around the MEWP when you raise the platform. Do not lower the platform unless the area below is clear of personnel and obstructions. If you do not obey, there is a risk of death or serious injury.

WARNING

If the platform is overloaded because of contact with an overhead obstruction, do one of the steps that follow:

- Remove the obstruction from the platform. Then after four seconds, you can operate the normal functions.
 - Use the emergency-power unit to release the platform from the obstruction (refer to [Section 3.4-7](#)).
-

WARNING

Fall hazard. Do not try to free a snagged platform with the base controls until you remove all personnel from the platform. If you do not obey, there is a risk of death or serious injury.

6.1-1 At the base control console:

1. Make sure the engine is off.
2. Pull the **emergency-stop** button.
3. Select the **base position** from the **off/base/platform key** switch.
4. Select the **emergency power position** from the **start/function enable/emergency power** switch and operate the necessary boom function(s).

6.1-2 At the platform control console:

1. Make sure the engine is off.
2. Pull the **emergency-stop** button.
3. Select the **on position** from the **engine start/on/off** switch.
4. Press and hold the **footswitch**.
5. Select the **emergency power position** from the **emergency-power unit** switch and operate the necessary boom function(s).

6.2 Chassis tilt recovery

IMPORTANT

When the boom is raised or extended, the MEWP must be operated on a firm, level surface.

WARNING

Tip-over hazard. When the tilt settings are exceeded, the alarm makes a sound and the light illuminates. The platform must be lowered and retracted immediately (refer to [Section 3.4-5](#)). If you do not obey, there is a risk of death or serious injury.

6.2-1 Platform uphill

If the MEWP becomes tilted with the platform uphill (refer to [Figure 08](#)), follow the steps below to go back to a lowered and retracted position.

1. Lower the jib to horizontal (if equipped)
2. Fully retract the main boom
3. Fully lower the main boom.
4. Drive to a firm, level surface.

6.2-2 Platform downhill

If the MEWP becomes tilted with the platform downhill (refer to [Figure 09](#)), follow the steps below to go back to a lowered and retracted position.

1. Fully retract the main boom.
2. Drive to a firm, level surface.



Figure 08 Platform uphill



Figure 09 Platform downhill

6.3 Release the brakes manually

⚠ WARNING

Do not manually disengage the brakes if the MEWP is on a slope. If you do not obey, there is a risk of death or serious injury.

1. Make sure that the MEWP is on firm, level ground. Use wheel chocks or blocks at the front and rear side of the wheels to prevent MEWP movement.
2. Turn the **main power disconnect** switch to the off position.

⚠ CAUTION

Do not use the hydraulic power with the brake disengaged.

3. Find the drive-bypass valve on the inboard side of the drive pump. Loosen the valve stem **1** (identified with yellow paint) 90 degrees clockwise to bypass the drive pump.

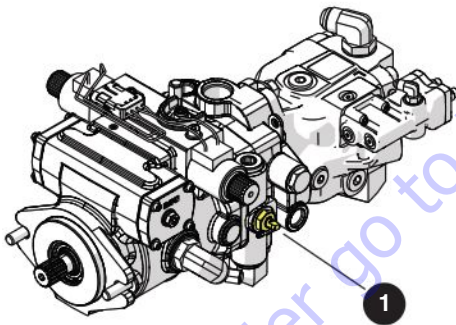

⚠ CAUTION

Do not release the brakes before you disengage the drive motor.

4. Push the plunger **2** of the brake auto-reset valve on the brake manifold.

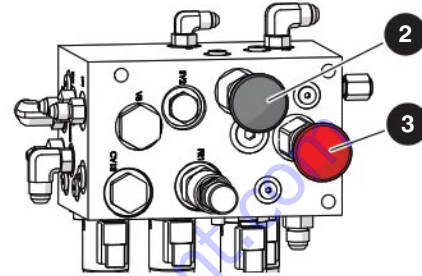

NOTE

If the MEWP does not have a pressure gauge, refer to the service manual for the installation procedure.

5. Continuously push and release the **knob 3** of the hand pump until firm resistance is felt or until the pressure gauge (optional equipment) shows 300 - 430 psi (2068 - 2965 kPa). The brake is now released to permit wheel rolling.

6.4 Winch and tow the MEWP

⚠ WARNING

Tip-over hazard. Make sure the boom is fully retracted and lowered before you winch or tow, unless movement is necessary to clear an obstacle. Sudden movement can cause the MEWP to become unstable.

In emergency situations where the MEWP functions are not available and an obstruction prevents the platform lower function, carefully move the MEWP sufficiently far away to clear the obstruction. Do not move at a speed faster than 50 mm/sec (2 in/sec).

If you do not obey, there is a risk of death, serious injury, and/or MEWP damage.

⚠ WARNING

Runaway hazard. After you release the brakes, the MEWP rolls freely on slopes. Do not manually disengage the brakes unless the MEWP is on a level surface or the MEWP is fully restrained.

Keep the travel path clear at all times.

If you do not obey, there is a risk of death, serious injury, and/or MEWP damage.

⚠ WARNING

When you winch or tow, do not move the MEWP at a speed faster than 3.2 km/h (2.0 mph). If you do not obey, there is a risk of death or serious injury.

1. Before you winch or tow the MEWP, fully retract and lower the boom.
2. Rotate the turret until the boom is in line with the chassis, in the direction of travel.
3. Release the brakes manually. Refer to [Section 6.3](#).
4. Remove the wheel chocks or blocks.
5. Winch or tow the MEWP to the necessary location.
6. Put the MEWP on a firm, level surface.
7. Use wheel chocks or blocks if necessary.
8. Find the drive-bypass valve on the inboard side of the drive pump. Loosen the valve stem **1** (identified with yellow paint) 90 degrees counterclockwise to engage the drive pump.

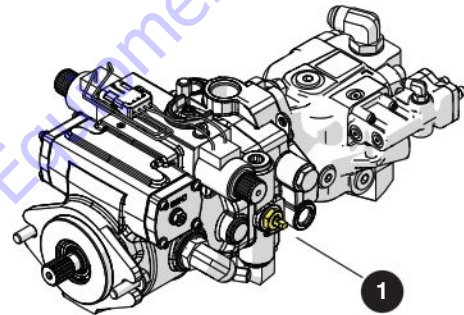

9. Pull out the **plunger** of the brake auto-reset valve to re-engage the brakes.

NOTE

The brakes automatically engage when you operate the platform controls.

⚠ WARNING

Engage the brakes immediately after the MEWP is at the necessary location. If you do not obey, there is a risk of death or serious injury.

6.5 Refuel

CAUTION

When operating on a slope, make sure the fuel level is above half to prevent a possible stall condition.

IMPORTANT

Before you use the MEWP, make sure that there is sufficient fuel for the estimated task.

WARNING

Do not start the MEWP if you smell gas. Lock and tag the MEWP, and remove it for servicing. If you do not obey, there is a risk of death or serious injury.

WARNING

Do not operate a MEWP that does not function correctly. Lock and tag the MEWP, and remove it for servicing. Only a qualified service technician must repair the MEWP. If you do not obey, there is a risk of death or serious injury.

WARNING

Explosion hazard. Only refuel the MEWP in a well-ventilated area, away from open flame and other sources of ignition, approved by your employer and/or supervisor. Always have an approved fire extinguisher that you can easily access. If you do not obey, there is a risk of death or serious injury.

WARNING

Explosion hazard. Do not smoke in an area where MEWPs are kept or refueled. If you do not obey, there is a risk of death or serious injury.

6.5-1 Refuel the MEWP with diesel

IMPORTANT

For diesel engines, use ultra-low sulfur diesel. Refer to the information on the fuel tank.

1. Put all the power connections in the off position. This includes the engine.
2. Push all the **emergency-stop** buttons, and turn the **main power disconnect** switch to the off position.

WARNING

Environmental hazard. Immediately remove gasoline, diesel fuel, engine oil, and hydraulic fluid spills and leaks with rags. Discard these rags in accordance with national, state/provincial/territorial, and local regulations. Spilled fluids can damage the environment. When spilled fluids go into the water (for example, a sewage system, streams, rivers, or other surface water), they can kill aquatic life.

3. Open the control compartment cowling and remove the fuel cap.
4. Carefully fill the fuel tank. Make sure that there are no spills. At the same time, look at the fuel gauge on the side of the tank. The fuel gauge indicator must not go above the F (full) mark.
5. Put the fuel cap back on and make sure it closes tightly.
6. Do an inspection of the fuel system for leaks. Clean away the spilled fuel.
7. Discard the wipes or rags in an approved container.

6.6 Move the MEWP for transport

When you drive a MEWP onto or remove it from a transport vehicle, on a public road, give protection to the person(s) involved. Protection can include:

- Warning cones
- Road signs and signaling devices
- Applicable personal protective equipment, such as reflective clothing
- Flag personnel to warn other vehicles of the MEWP and other related vehicles
- Other applicable control measures.

Obey all the national, state/provincial/territorial, and local safety rules when you move the MEWP for transport. Only qualified personnel with authorization must drive the MEWP on to or remove it from a transport vehicle.

Be sure the vehicle capacity and load equipment, hoists, chains, straps, and other related items are sufficient to withstand the maximum MEWP weight.

Park the transport vehicle on a level surface. Use wheel chocks or blocks to prevent unintended vehicle movement during this operation.

6.6-1 Lock the turret

1. Rotate the turret until the transportation lock **2** is in line over the of the lock points **3** on the chassis.
2. Lift and turn the lock pin **1** and lower it into the lock point on the chassis.

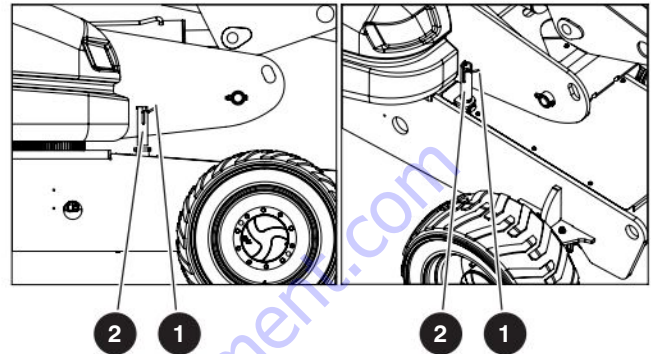

Figure 10 Turret transportation lock

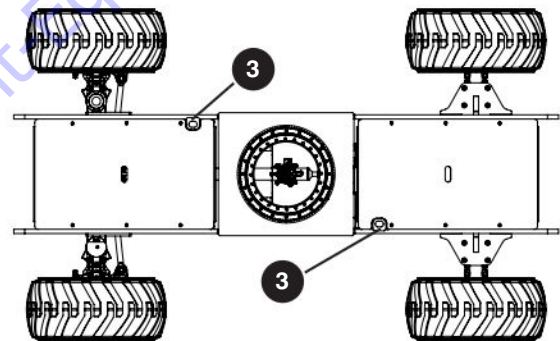

Figure 11 Turret transportation lock points

6.6-2 Hoist the MEWP

WARNING

Only qualified riggers must operate the machinery during a lift.

1. Rotate the boom and position the MEWP as shown in [Figure 12](#).
2. Turn the **main power disconnect** switch to the off position.
3. Remove all personnel, tools, and materials from the platform.

WARNING

When you hoist the MEWP, the lifting devices must be attached to the designated lift points only. Refer to [Figure 12](#).

WARNING

Use chains with a load capacity sufficient to withstand the MEWP weight. Refer to the serial plate of the MEWP for the specified weight.

4. Attach the rigging to all four lift points as shown in [Figure 12](#).
5. Adjust the rigging to make sure the MEWP stays level when you hoist it. Refer to [Figure 12](#) for the center of gravity location.

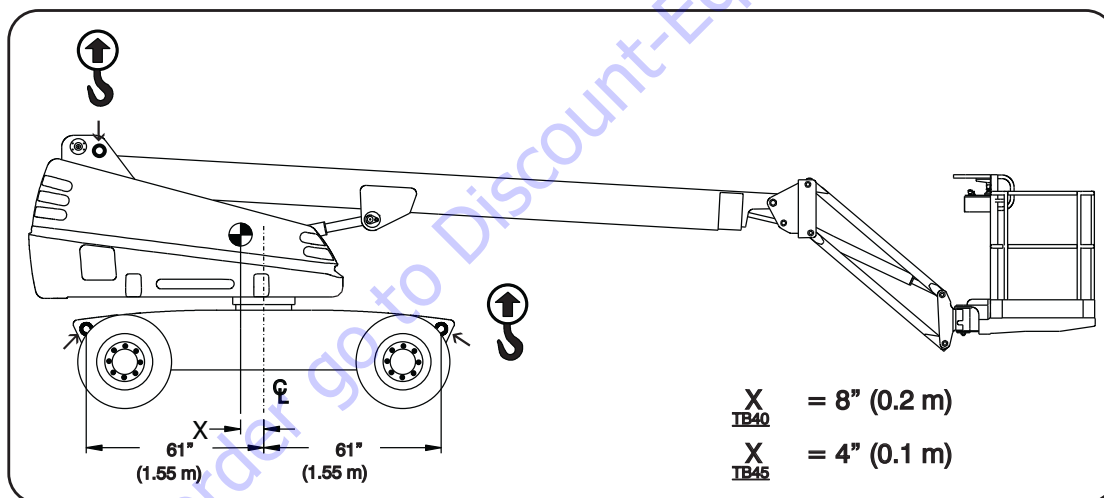

Figure 12 Lift points and center of gravity

NOTE

Horizontally, the **center of gravity** is approximately in the middle of the MEWP, front to rear and side to side. Vertically, the center of gravity is approximately a small distance above the chassis.

6.6-3 Tie down the MEWP

1. Lock the turret with the turret transportation lock. Refer to [Section 6.6-1](#).
2. Turn the off/base/platform key switch to the off position and remove the key before you transport the MEWP.
3. Turn the main power disconnect switch to the off position.
4. Use wheel chocks or blocks at the front and rear side of the wheels if necessary.
5. Remove all loose or unsecured items.

WARNING

When you transport the MEWP, it must be attached to a truck or trailer deck. Use the available tie-down points to attach the MEWP. If you do not obey, there is a risk of death or serious injury.

6. Tie-down the MEWP to the transport surface with the tie-down points.

7. Put the lower platform mount between the boom end and the platform to prevent side-to-side movement of the boom. Do not use excessive downward force when you secure the boom section.
8. Put a block below the platform rotator. Carefully lower the rotator onto the block and secure it in position. Secure the strap below the hoses and cables to prevent damage to the MEWP. Do not use excessive downward force when you secure the platform.

WARNING

Do an inspection of the MEWP for loose or unsecured items.

NOTE

When you move the MEWP for transport with a winch line, refer to [Section 6.4](#).

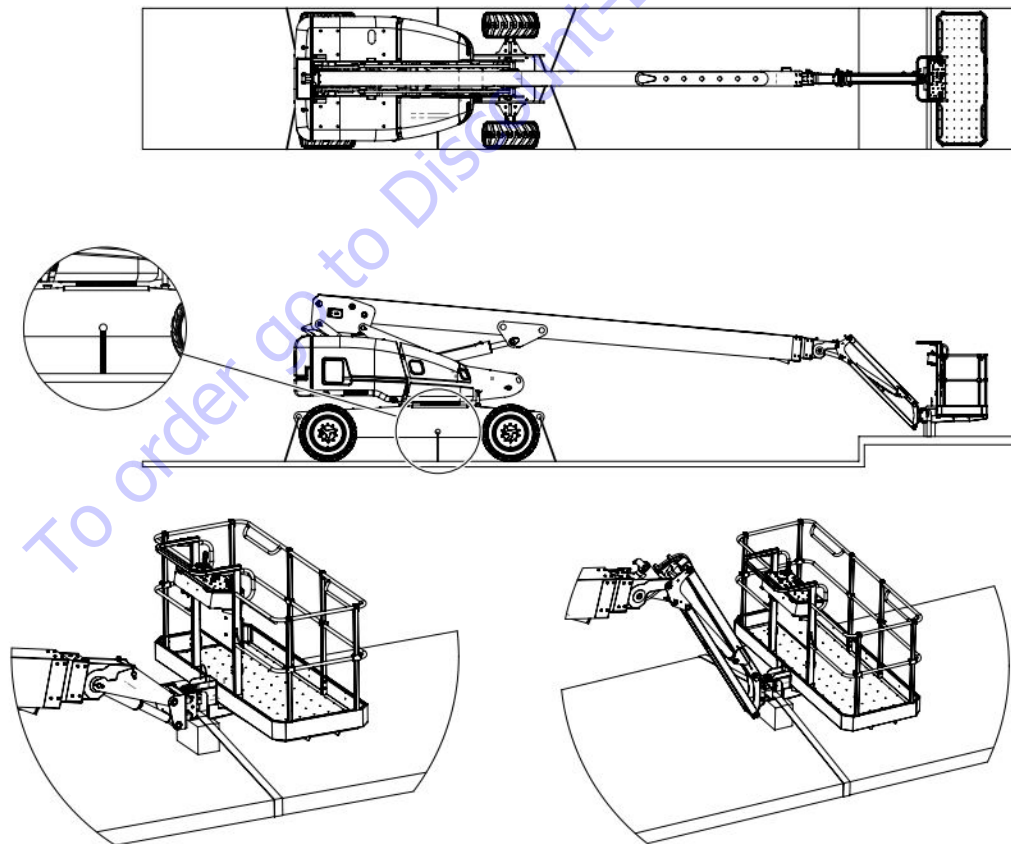

Figure 13 No Jib platform tie-down

Figure 14 Jib platform tie-down

Section 7 – Technical Diagrams and Specifications

To order go to Discount-Equipment.com

7.1 Technical diagrams

7.1-1 Reach diagram - SJ40 T+

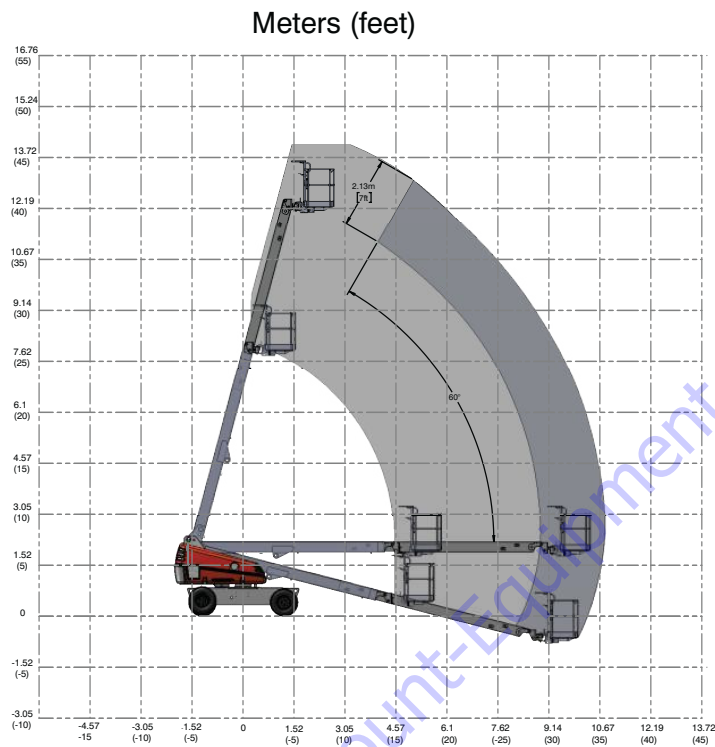

7.1-2 Reach diagram - SJ45 T+

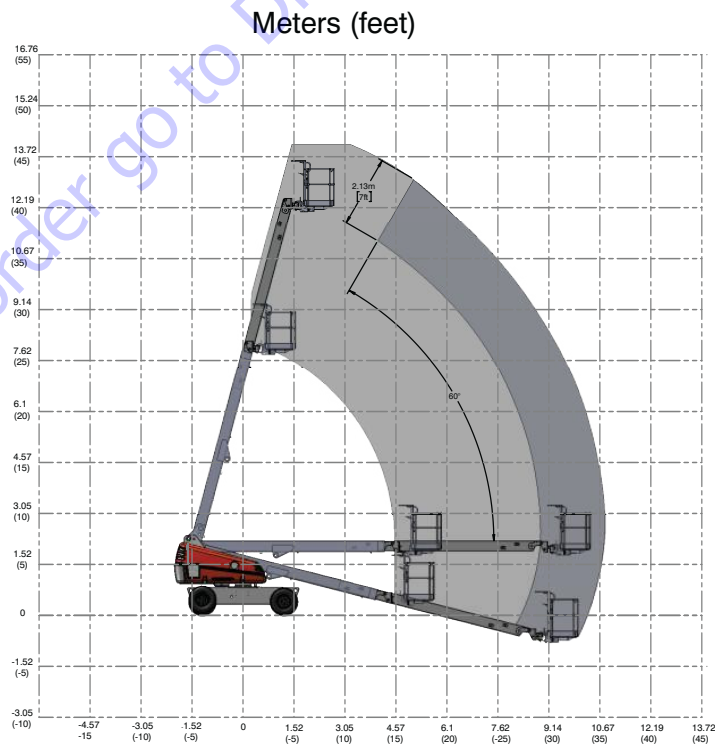

7.1-3 Dimensions - SJ40 T+

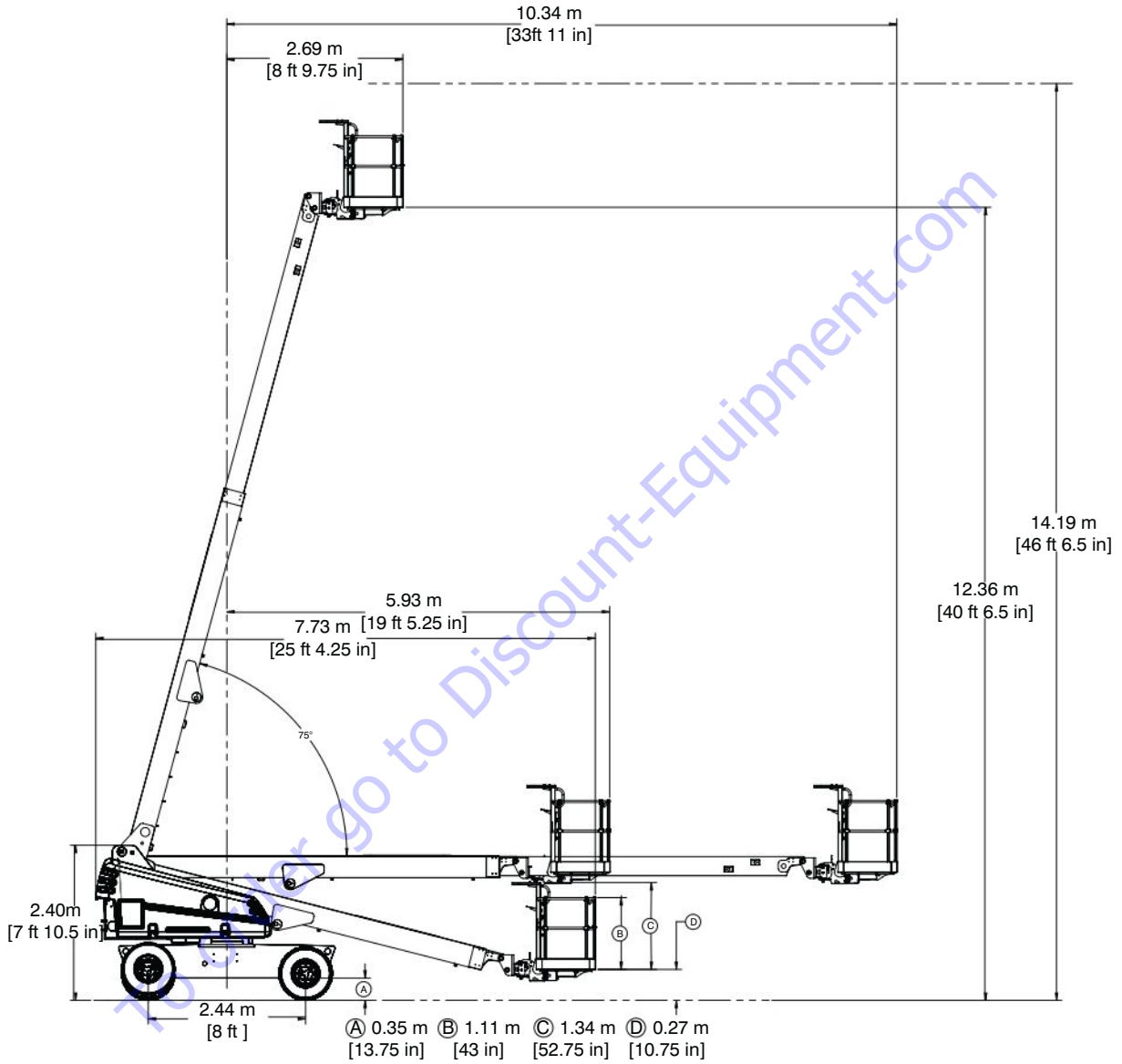

Dimensions - SJ40 T+ (continued)

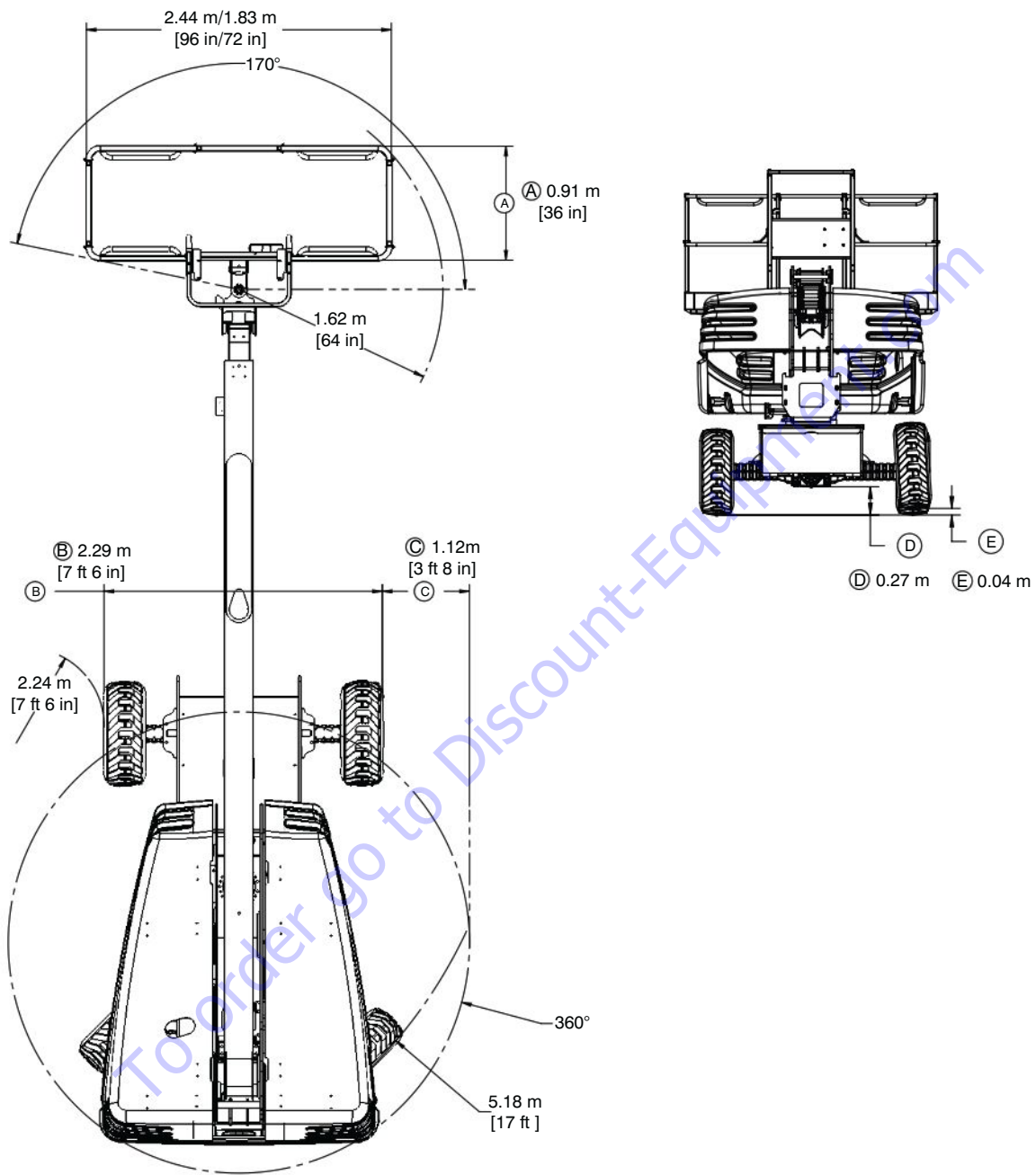

7.1-4 Dimensions - SJ45 T+

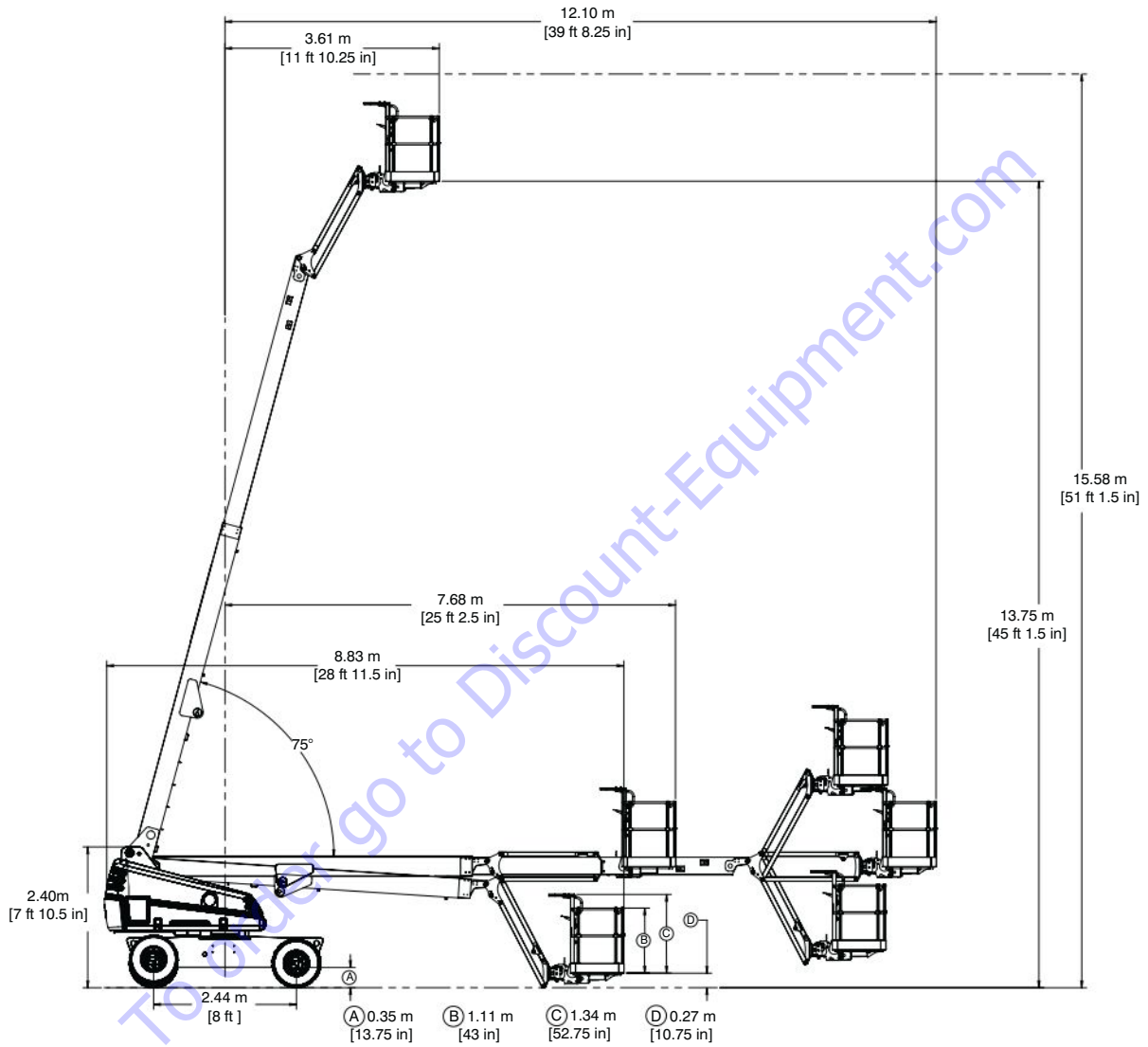

Dimensions - SJ45 T+ (continued)

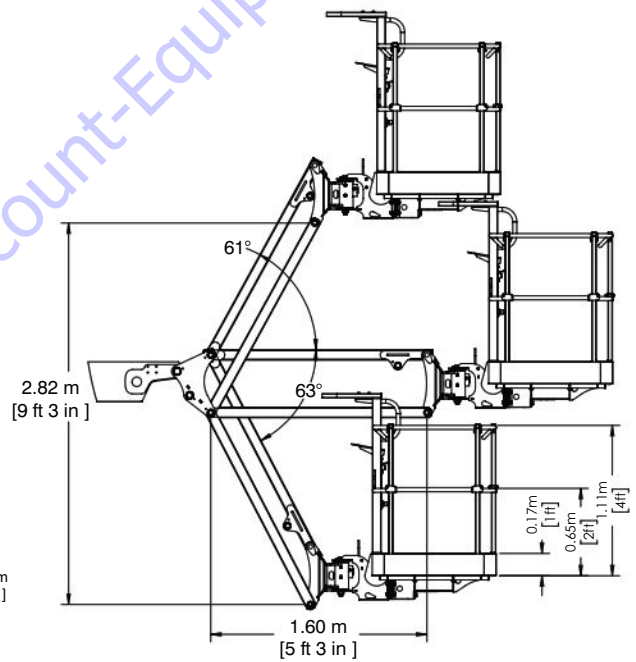
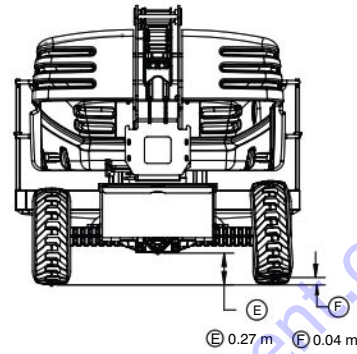
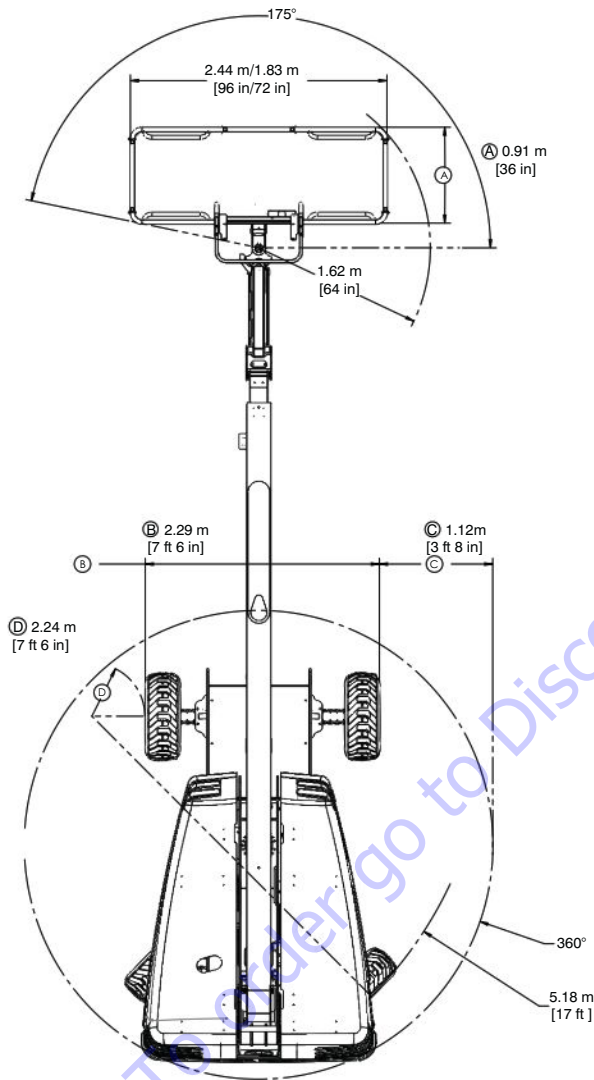

7.2 Standard and optional equipment

Model	SJ40 T+	SJ45 T+
Standard Equipment		
1.60 m (5 ft 3 in) jib		*
12 Volt DC emergency power	*	*
2.44 m x 0.91 m (96 in x 36 in) platform	*	*
AC socket on platform	*	*
Base controls	*	*
Continuous drive and steer directional sensing	*	*
Diesel engine	*	*
Dual capacity rating	*	*
Engine anti-restart protection	*	*
Four-wheel drive	*	*
Glow plug heaters	*	*
Load sensing system	*	*
Manual brake release	*	*
Motion alarm	*	*
Operator horn	*	*
Operator-engaged differential lock	*	*
Oscillating axle (steer)	*	*
Platform controls	*	*
SGE	*	*
Solid tires	*	*
Spring-applied hydraulically released brake system	*	*
Tri-entry drop bar	*	*
Variable speed drive and function controls	*	*
Optional Equipment		
1.83 m x 0.91 m (72 in x 36 in) platform	*	*
Arctic weather package	*	*
Bio oil	*	*
Cold weather start kit	*	*
Control box cover	*	*
Diesel scrubber	*	*
External platform top rail	*	*
Flashing amber light	*	*
Foam-filled tires		*
Generator	*	*
Glazier Rack	*	*
Non-marking foam filled tires		*
Non-marking solid tires	*	*
Pipe rack	*	*
Positive air shut-off	*	*
Side-entry spring-hinged gate	*	*
Solid non-marking tires	*	*
Tool caddy	*	*
Welder package with generator	*	*
Elevate Telematics™	*	*

2126AA

7.3 Owner's annual inspection record



Model _____ SN _____

Inspection Date: 31

	20	20	20	20	20	20	20	20	20	20	20
Inspector Signature	SKYJACK										

IMPORTANT

The owner's annual inspection record is on the cowling of the control compartment. It must be filled out after an annual inspection has been completed. Do not use the MEWP if an inspection has not been recorded in the last 13 months.

To order go to Discount-Equipment.com

7.4 Specifications

		SJ40 T+		SJ45 T+	
Height & Reach	Working Height - maximum	14.19 m	46 ft 6.5 in	15.58 m	51 ft 1.5 in
	Platform Height - maximum	12.36 m	40 ft 6.5 in	13.75 m	45 ft 1.5 in
	Horizontal Reach - maximum	10.34 m	33 ft 11 in	12.10 m	39 ft 8.25 in
	Horizontal Reach - at maximum height	2.69 m	8 ft 9.75 in	3.61 m	11 ft 10.25 in
	Horizontal Reach - fly boom retracted	5.93 m	19 ft 5.25 in	7.68 m	25 ft 2.5 in
	Tailswing	1.12 m	3ft 8 in	1.12 m	3ft 8 in
Platform	Platform Size	0.91 m x 2.44 m	36 in x 96 in	0.91 m x 2.44 m	36 in x 96 in
		0.91 m x 1.83 m	36 in x 72 in	0.91 m x 1.83 m	36 in x 72 in
	Platform Rotation	173°		173°	
Jib	Jib Length	N/A		1.60 m	5 ft 3 in
	Jib vertical Range of Motion	N/A		2.82 m	9 ft 3 in
	Jib Range of Motion - down	N/A		63°	
	Jib Range of Motion - up	N/A		61°	
Dimensional Data	Height - stowed min.	2.40 m	7 ft 10.5 in	2.40 m	7 ft 10.5 in
	Stowed length @ min. height	7.73 m	25 ft 4.25 in	8.83 m	28 ft 11.5 in
	Width	2.29 m	7 ft 6 in	2.29 m	7 ft 6 in
	Wheelbase	2.44 m	8 ft	2.44 m	8 ft
	Ground Clearance - chassis	0.35 m	13.75 in	0.35 m	13.75 in
	Ground Clearance - front axle	0.27 m	10.75 in	0.27 m	10.75 in
	Axle Oscillation	0.07 m	2.77 in	0.13 m	5.26 in
	Turning Radius - inside	2.24 m	7 ft 6 in	2.24 m	7 ft 6 in
	Turning Radius - outside	5.18 m	17 ft	5.18 m	17 ft
		Turret Rotation	360°		360°
Performance & Speeds	Gradeability - maximum	50%		50%	
	Drive Speed - stowed / low torque	4.8 km/h	3 mph	4.8 km/h	3 mph
	Drive Speed - stowed / high torque	2.1 km/h	1.3 mph	2.1 km/h	1.3 mph
	Drive Speed - elevated	0.58 km/h	0.36 mph	0.8 km/h	0.5 mph
	Turret Rotation Time - stowed	80 - 110 sec		90 - 110 sec	
	Platform Rotation Time	5 - 9 sec		5 - 9 sec	
	Boom Up Time	43 - 46 sec		43 - 46 sec	
	Boom Down Time	45 - 48 sec		45 - 48 sec	
	Boom Extend Time	30 - 40 sec		30 - 40 sec	
	Boom Retract Time	30 - 40 sec		30 - 40 sec	
	Jib Up Time	N/A		18 - 28 sec	
	Jib Down Time	N/A		10 - 16 sec	
	Steer Left Time	5 - 9 sec		5 - 9 sec	
Steer Right Time	5 - 9 sec		5 - 9 sec		
Electrical	System Voltage	12 V DC		12 V DC	
	Battery Type	Lead / Acid		Lead / Acid	

2099AA

7.5 Environment

Electromagnetic Compatibility (EMC)	Meets requirements of EN ISO 13766-1:2018 and IEC CISPR12:2007+A1:2009
Hazardous Location Rating	MEWP not rated for hazardous locations with potentially flammable gases, explosive gases or particles
Operating Temperatures	
Standard	-20°C (-4°F) to +40°C (+104°F)
Cold Weather Package	Below -10°C (+14°F)
Arctic Weather Package	Below -18°C (0°F)

1848AB

7.6 Tire/wheel specifications

Tire	Type	Size	Ply Rating	Wheel Nut Torque
SJ40 T+	Solid	25.4 cm x 76.2 cm (10 in x 31 in)	-	393.2 Nm (290 ft-lb)
SJ45 T+	Foam	30.5 cm x 41.9 cm (12 in x 16.5 in)	10 or 12	393.2 Nm (290 ft-lb)
	Solid	25.4 cm x 76.2 cm (10 in x 31 in)	-	393.2 Nm (290 ft-lb)

2127AA

WARNING

Do not use tires other than the tires that Skyjack specifies for this MEWP. Do not mix different types of tires or use tires that are not in good condition. Only replace the tires with the same types that are approved by Skyjack. The use of other tires can make the MEWP less stable. If you do not obey, there is a risk of death or serious injury.

7.7 Maximum platform capacities (evenly distributed)

SJ40 T+		Regular Platform Capacity		Derated Platform Capacity*	
High-capacity zone	Capacity	454 kg	1000 lb	454 kg	1000 lb
	Maximum number of people	3	3	1	1
	Manual side force	400 N	90 lbf	200 N	45 lbf
Low-capacity zone	Capacity	340 kg	750 lb	318 kg	700 lb
	Maximum number of people	2	2	1	1
	Manual side force	400 N	90 lbf	200 N	45 lbf
Wind rating	-	12.5 m/s	28 mph	12.5 m/s	28 mph
Tilt cutout setting	side-to-side x front-to-back	5 degrees x 5 degrees		5 degrees x 5 degrees	

2102AA

SJ45 T+		Regular Platform Capacity		Derated Platform Capacity*	
High-capacity zone	Capacity	454 kg	1000 lb	454 kg	1000 lb
	Maximum number of people	3	3	1	1
	Manual side force	400 N	90 lbf	200 N	45 lbf
Low-capacity zone	Capacity	300 kg	660 lb	272 kg	600 lb
	Maximum number of people	2	2	1	1
	Manual side force	400 N	90 lbf	200 N	45 lbf
Wind rating	-	12.5 m/s	28 mph	12.5 m/s	28 mph
Tilt cutout setting	side-to-side x front-to-back	5 degrees x 5 degrees		5 degrees x 5 degrees	

2103AA

NOTE

Refer to sections 5.23 and 5.24 for the capacity derate switch operation.

7.8 Floor loading pressure

Model		Weights				Pressures			
		MEWP Weight		Weight per Wheel**		LCP***		OFL***	
		kg	lb	kg	lb	kPa	psi	kPa	psf
SJ40 T+	Min*	6,586	14,520	1,905	4,200	857	124	8.6	180
	Max*	7,041	15,520	3,495	7,700	1,223	177	9.2	192
SJ45 T+	Min*	7,120	15,700	2,041	4,500	884	125	9.3	195
	Max*	7,575	16,700	4,082	9,000	1,414	205	9.9	207

2106AA

* **Min:** Minimum MEWP weight (Unloaded platform, no options/attachments)
Max: Maximum MEWP weight (Platform loaded to capacity with options/attachments)

** **Wheel Load** is the weight that can be experienced on one wheel.
Note: This is more than 25% of the machine weight due to possible weight distribution over the machine and platform.

*** **LCP:** Local Concentrated Pressure is a measure of how hard the MEWP presses on the area in direct contact with the floor/tire.
OFL: Overall Floor Load (Pressure) is a measure of the average load the MEWP imparts on the whole surface directly underneath the chassis. This has been calculated by dividing the MEWP weight by the overall floor area occupied by the MEWP (on wheels).

Note: The floor covering (e.g., tile, carpet, etc.) or the structure (e.g., beams) of the operating surface must be able to withstand more than the values indicated above.

NOTE

The LCP or OFL that an individual surface can withstand varies from structure to structure and is generally determined by the engineer or architect for that particular structure.

Section 8 – Labels

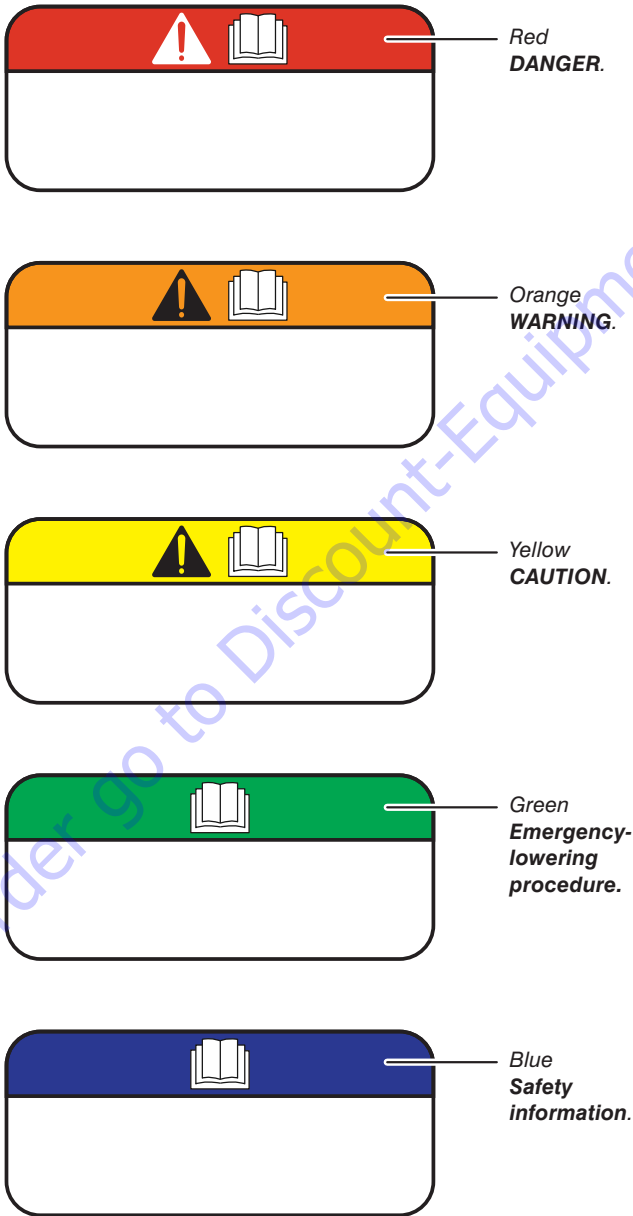
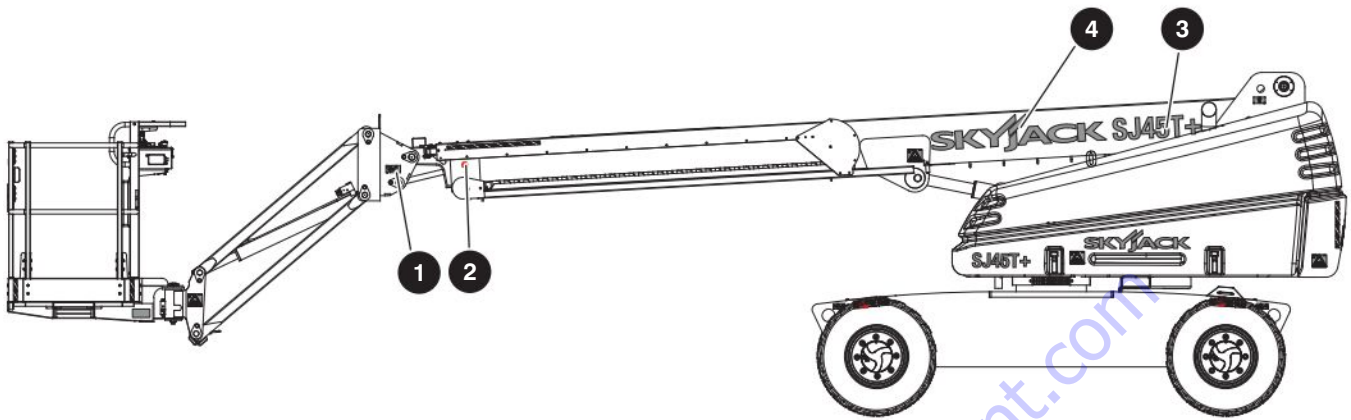

Figure 15 Label legend

8.1 Engine side



Description	Label Pictorial
<p>1 Warning - crush hazard</p>	
<p>2 Do not alter Do not tamper with or disable the limit switches or other safety devices.</p>	
<p>3 Model number* Product identifier. <i>*The model number can be different from the one you see.</i></p>	<p>SJ45 T+</p>
<p>4 Skyjack logo</p>	

Engine side (continued)

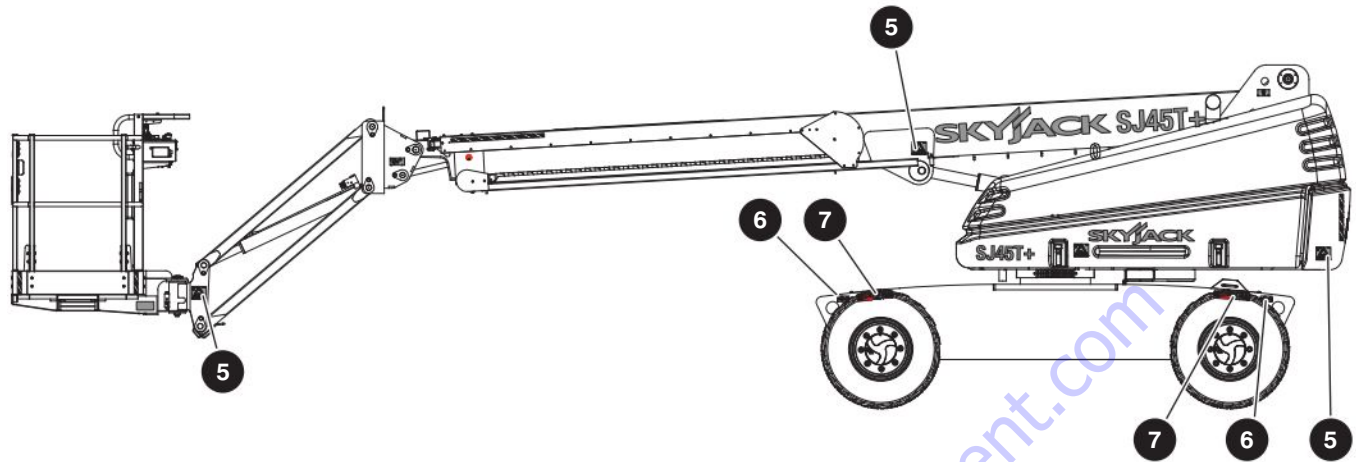

Description	Label Pictorial
-------------	-----------------

5 Warning - body crush hazard



6 Lift and tie-down points

Only use these points to lift or tie-down the MEWP.



7 Wheel load*

Shows the maximum load applied to the ground by the specified wheel.

*Each model has different wheel loads.

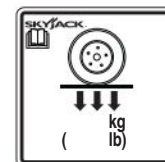

Engine side (continued)

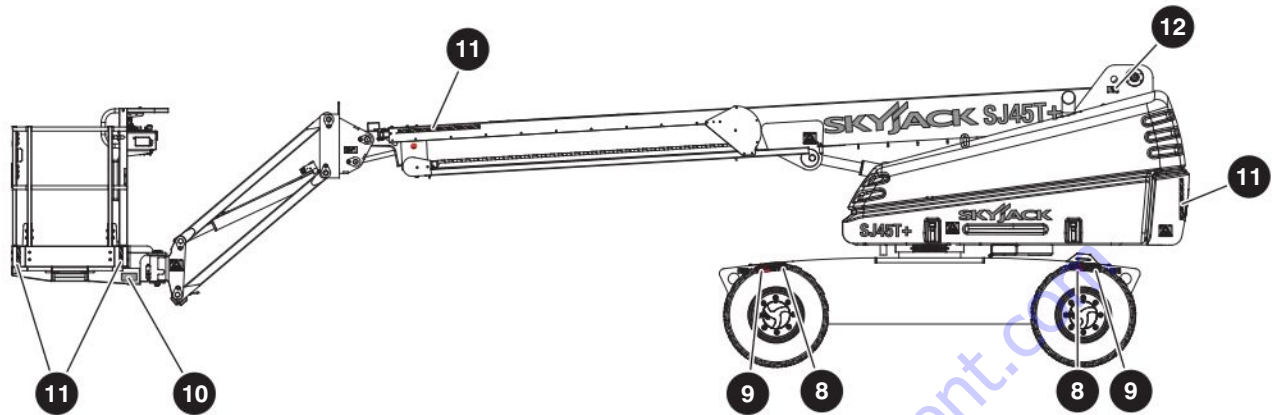

Description	Label Pictorial
<p>8 Tip-over hazard Do not use air-filled tires. Use approved, matched tires only. Refer to Section 7.</p>	
<p>9 Wheel specifications Refer to the service manual for the wheel type, offset, pressure, and torque.</p>	
<p>10 Tie-down points Only use these points to tie-down the MEWP.</p>	
<p>11 Caution tape stripe</p>	
<p>12 Lift points Only use these points for lifting.</p>	

8.2 Engine compartment

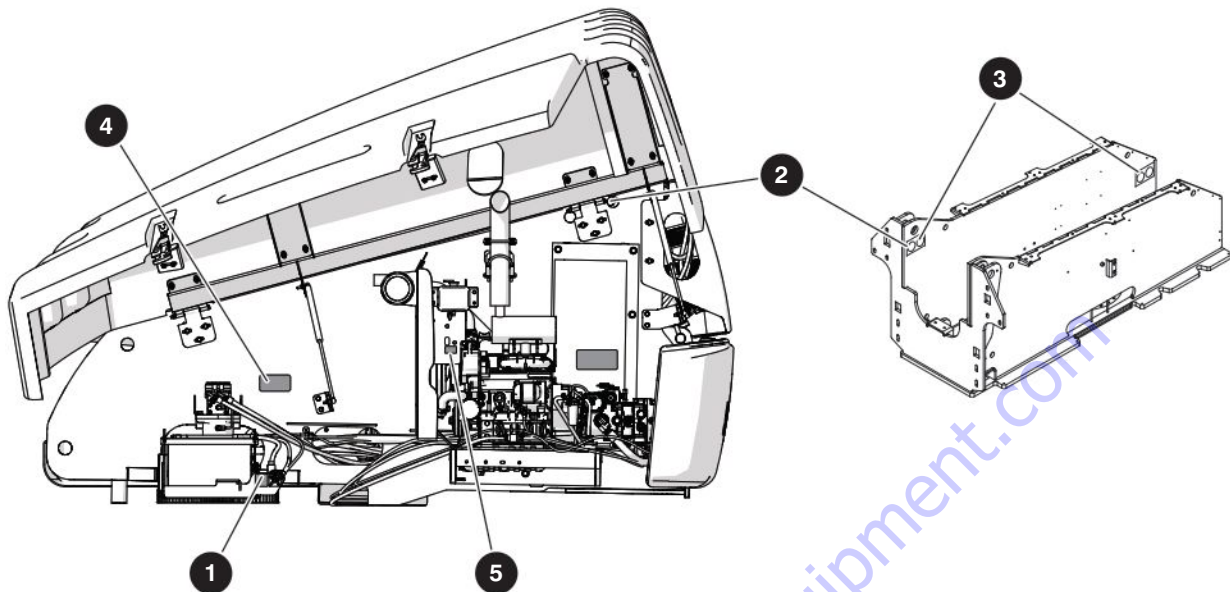

Description	Label Pictorial
<p>1 Main power disconnect switch</p> <p>Turn the switch clockwise to turn the power on. Turn the switch counterclockwise to turn the power off. Use a padlock to lock the switch in position.</p>	
<p>2 Do not alter</p> <p>Do not tamper with or disable the limit switches or other safety devices.</p>	
<p>3 Warning - maintenance support</p> <p>Do not enter the space below the work platform or extending structure during maintenance unless a support structure is in position. Refer to the service manual for the instructions on machine power isolation and structure support during maintenance.</p>	
<p>4 QR code</p> <p>This code gives you fast access to the MEWP documentation, and the live MEWP data supplied by ELEVATE telematics (optional equipment).</p>	
<p>5 Positive air shut-off (optional equipment)</p> <p>Select the positive air shut-off switch to stop the air supply to the engine.</p>	

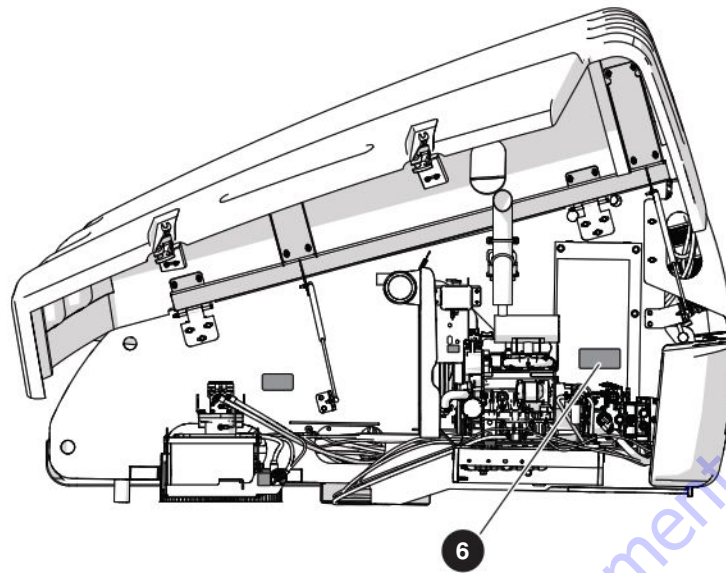
Engine compartment (continued)

Description

Label Pictorial

6 Winch and tow procedure

Refer to the operation manual.

1. Use wheel chocks or blocks at the front of the wheels and behind them to prevent MEWP movement.
2. Turn the **main power disconnect** switch to the off position.
3. At the engine side, find the drive-bypass valve (identified with yellow paint) on the inboard side of the drive pump.
4. Rotate the drive-bypass valve to a flat position with pliers or a 7 mm (1/4") wrench by 90 degrees clockwise.
5. At the hydraulic tank side, find the brake manifold.
6. Push the **plunger** of the brake auto-reset valve.
7. Continuously push and release the knob of the hand pump until firm resistance is felt or until the pressure gauge (optional equipment) shows 300 - 430 psi (2068 - 2965 kPa). The brake is now released to permit wheel rolling.
8. Remove the chocks or blocks from the wheels, and winch or tow the MEWP to the necessary location.
9. Use wheel chocks or blocks at the front of the wheels and behind them to prevent MEWP movement.
10. Pull out the **plunger** of the brake auto-reset valve to re-engage the brakes.
11. At the engine side, close the drive-bypass valve by rotating it 90 degrees counterclockwise to the normal position (flat is parallel to the shaft axis).

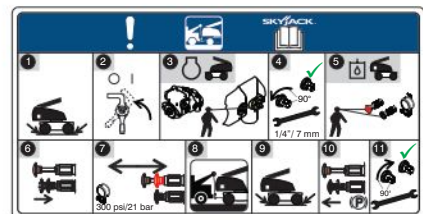
**NOTE**

Before operation, make sure you remove the chocks or blocks from the wheels.

8.3 Front



Description

Label Pictorial

1 Axldrive™ logo



2 Skyjack manufactured date

Shows the month and year of manufacture for this MEWP.



3 Serial plate*

MEWP identification and specifications.

**The serial plate information changes with different MEWPs.*

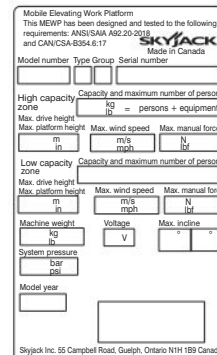

4 Caution tape stripe



8.4 Control side

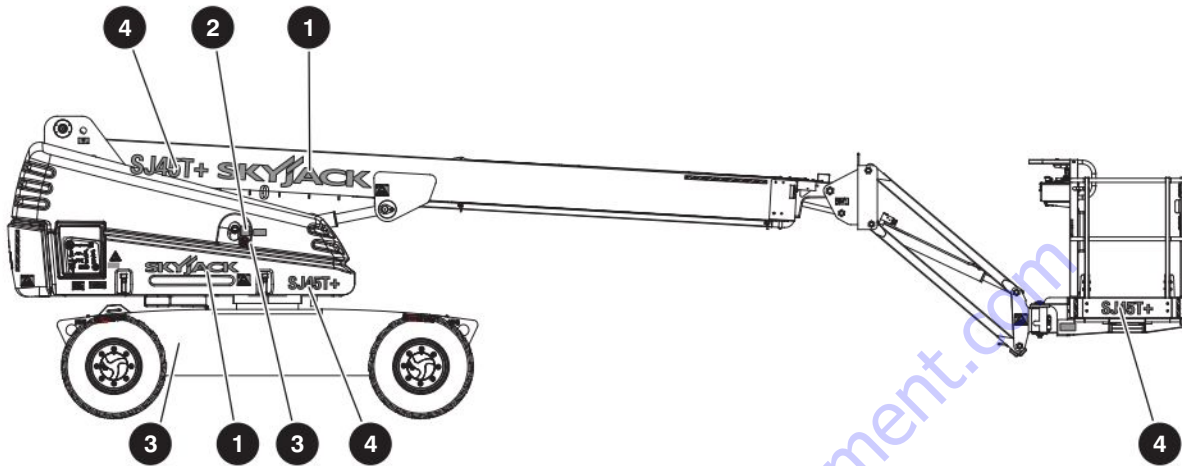

Description

Label Pictorial

1 Skyjack logo



2 Diesel

Only use ultra-low sulfur diesel.

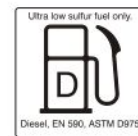

3 Do not smoke

Do not smoke near this location.



4 Model number*

Product identifier.

**The model number can be different from the one you see.*



Control side (continued)

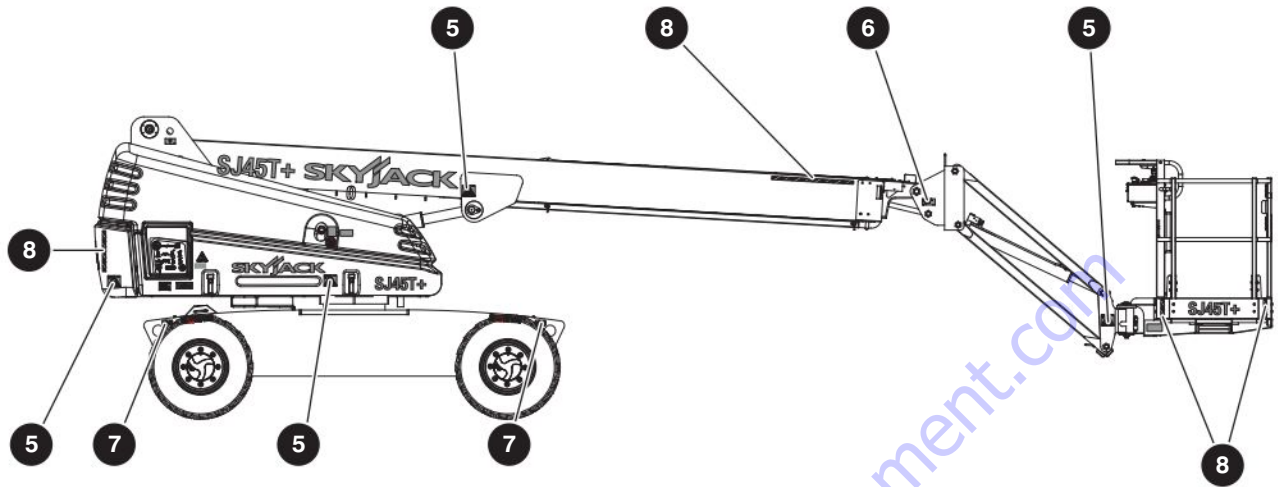

Description	Label Pictorial
<p>5 Warning - body crush hazard</p>	
<p>6 Warning - crush hazard</p>	
<p>7 Lift and tie-down points Only use these points to lift or tie-down the MEWP.</p>	
<p>8 Caution tape stripe</p>	

Control side (continued)

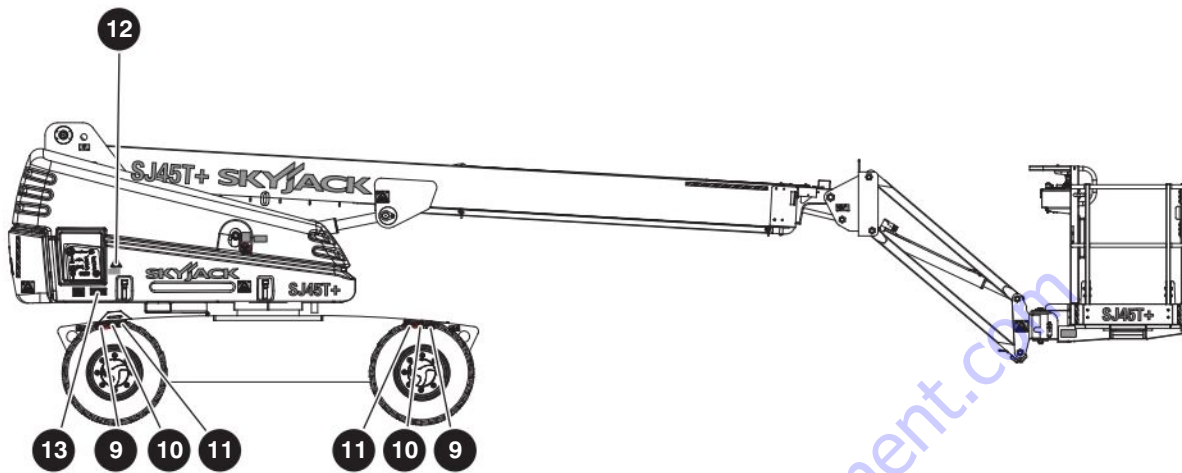

Description	Label Pictorial
<p>9 Tip-over hazard Do not use air-filled tires. Use approved, matched tires only. Refer to Section 7.</p>	
<p>10 Wheel load* Shows the maximum load applied to the ground by the specified wheel. <i>*Each model has different wheel loads.</i></p>	
<p>11 Wheel specifications Refer to the service manual for the wheel type, offset, pressure, and torque.</p>	
<p>12 Warning - annual inspection Refer to the operation manual. Make sure the annual and daily inspections are done.</p>	
<p>13 Annual inspection Make sure the MEWP has received an annual inspection before operation.</p>	

Control side (continued)

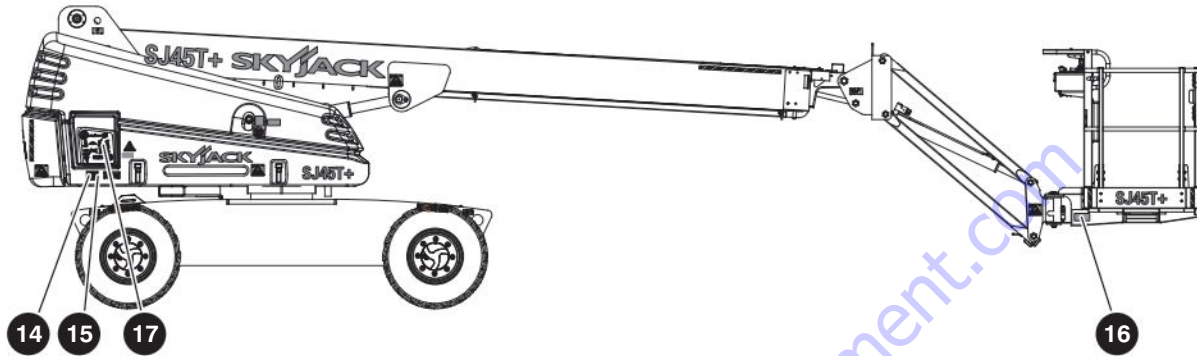

Description	Label Pictorial
<p>14 Emergency-lowering procedure Refer to the operation manual.</p> <ol style="list-style-type: none"> 1. Pull the emergency-stop button. 2. Turn the off/base/platform key switch to the base position. 3. Select the emergency-power position from the start/function enable/emergency-power switch and operate the necessary boom function to lower the platform. 	
<p>15 Emergency-lowering identification</p>	
<p>16 Tie-down points Only use these points to tie-down the MEWP.</p>	
<p>17 Elevate™ Trackunit (optional) This MEWP has added functionality.</p>	

Control side (continued)

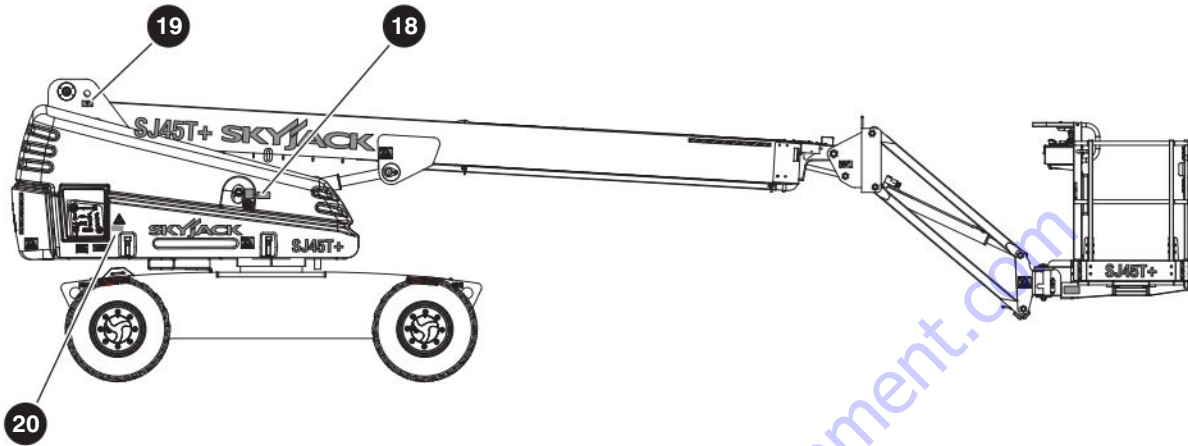

Description	Label Pictorial
<p>18 Slowly open the fuel cap Refer to the operation manual. Slowly open the fuel cap to prevent fuel spray from the fuel tank.</p>	
<p>19 Lift points Only use these points for lifting.</p>	
<p>20 QR code This code gives you fast access to the MEWP documentation, and the live MEWP data supplied by ELEVATE telematics (optional equipment).</p>	

8.5 Control compartment

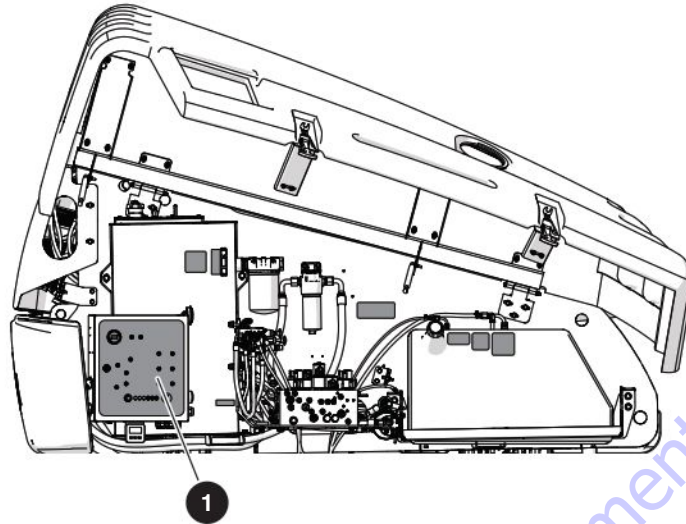

Description

Label Pictorial

1 Base control console

Push the **circuit breakers** to reset the power if a power overload or positive circuit grounding occurs.

Select the platform rotation switch to rotate the platform to the left or right.

Select the platform-leveling override switch to tilt the platform up or down.

Select the jib up/down switch to move the jib up or down.

Select the riser raise/lower switch to raise or lower the riser.

Select the turret rotation switch to rotate the turret to the left or right.

Select the main boom raise/lower switch to raise or lower the main boom.

Select the boom extend/retract switch to extend or retract the boom.

Select the off position to turn the engine off, the base position to energize the base controls, or the platform position to energize the platform controls.

Push the emergency-stop button to stop the engine and disable the controls.

Push and hold the start/function enable/emergency-power switch in the start position to start the engine.

Push and hold the start/function enable/emergency-power switch in the function enable position to enable the base control functions.

With the engine off, push and hold the start/function enable/emergency-power switch in the emergency-power position to enable the emergency-power unit for emergency descent.

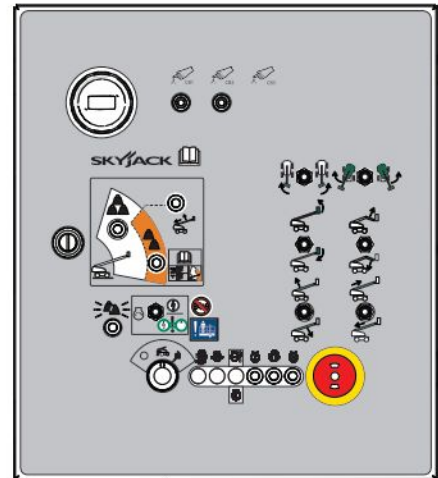

Control compartment (continued)

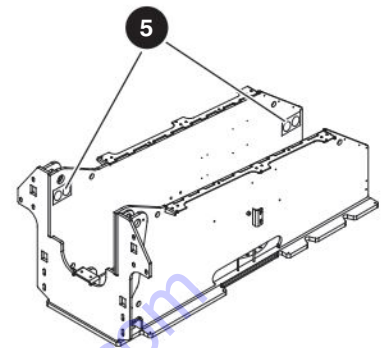
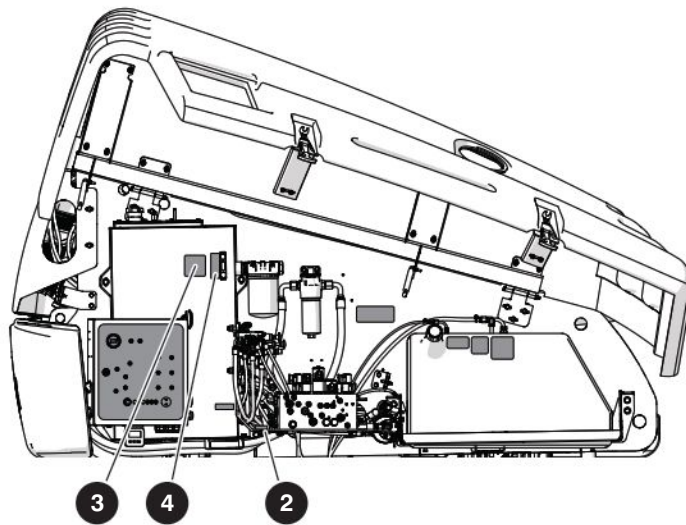

Description

Label Pictorial

2 Grease point maintenance

Refer to the service manual for how to lubricate the MEWP.



3 Hydraulic oil

Replace the hydraulic fluid with the approved type (refer to the service manual).

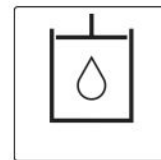

4 Hydraulic oil level

Shows the minimum and maximum hydraulic oil level.



5 Warning - maintenance support

Do not enter the space below the work platform or extending structure during maintenance unless a support structure is in position. Refer to the service manual for the instructions on machine power isolation and structure support during maintenance.

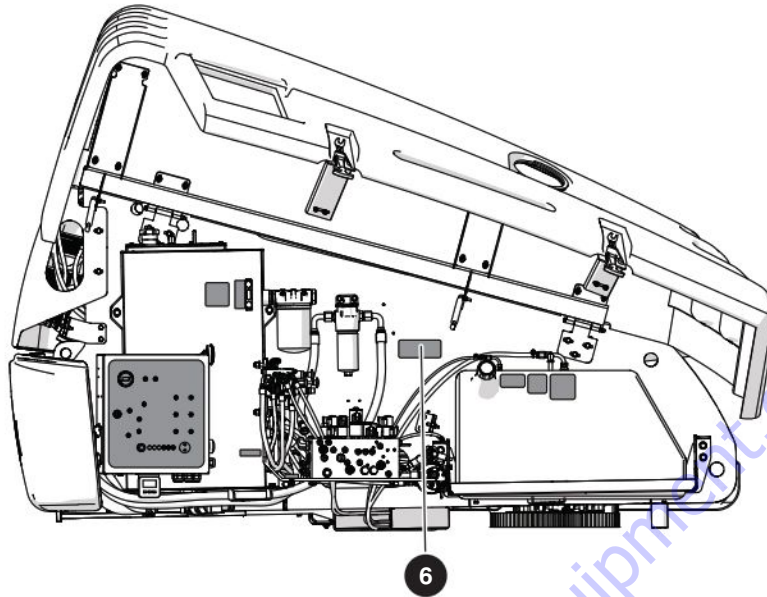

Control compartment (continued)

Description

Label Pictorial

6 Winch and tow procedure

Refer to the operation manual.

1. Use wheel chocks or blocks at the front of the wheels and behind them to prevent MEWP movement.
2. Turn the **main power disconnect** switch to the off position.
3. At the engine side, find the drive-bypass valve (identified with yellow paint) on the inboard side of the drive pump.
4. Rotate the drive-bypass valve to a flat position with pliers or a 7 mm (1/4") wrench by 90 degrees clockwise.
5. At the hydraulic tank side, find the brake manifold.
6. Push the **plunger** of the brake auto-reset valve.
7. Continuously push and release the knob of the hand pump until firm resistance is felt or until the pressure gauge (optional equipment) shows 300 - 430 psi (2068 - 2965 kPa). The brake is now released to permit wheel rolling.
8. Remove the chocks or blocks from the wheels, and winch or tow the MEWP to the necessary location.
9. Use wheel chocks or blocks at the front of the wheels and behind them to prevent MEWP movement.
10. Pull out the **plunger** of the brake auto-reset valve to re-engage the brakes.
11. At the engine side, close the drive-bypass valve by rotating it 90 degrees counterclockwise to the normal position (flat is parallel to the shaft axis).

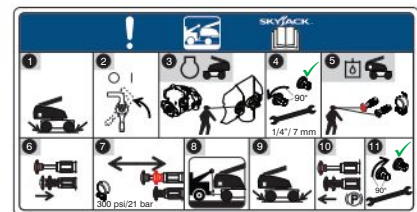
**NOTE**

Before operation, make sure you remove the chocks or blocks from the wheels.

Control compartment (continued)

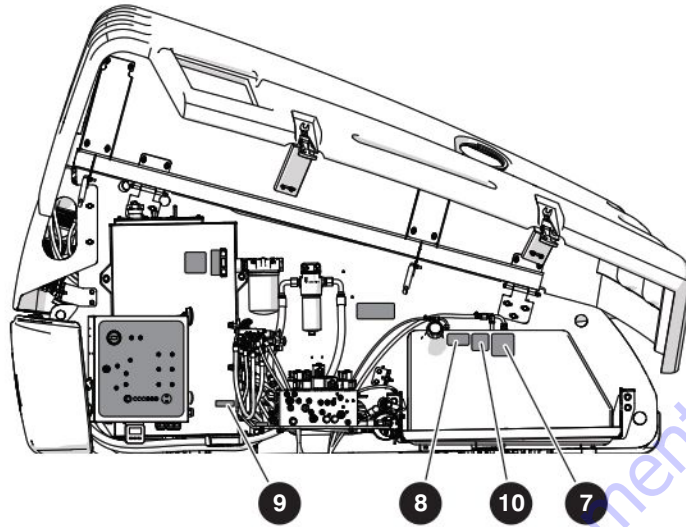

Description	Label Pictorial
<p>7 Do not smoke Do not smoke near this location.</p>	
<p>8 Slowly open the fuel cap Refer to the operation manual. Slowly open the fuel cap to prevent fuel spray from the fuel tank.</p>	
<p>9 AC power plug Connect the AC supply here.</p>	

8.6 Rear

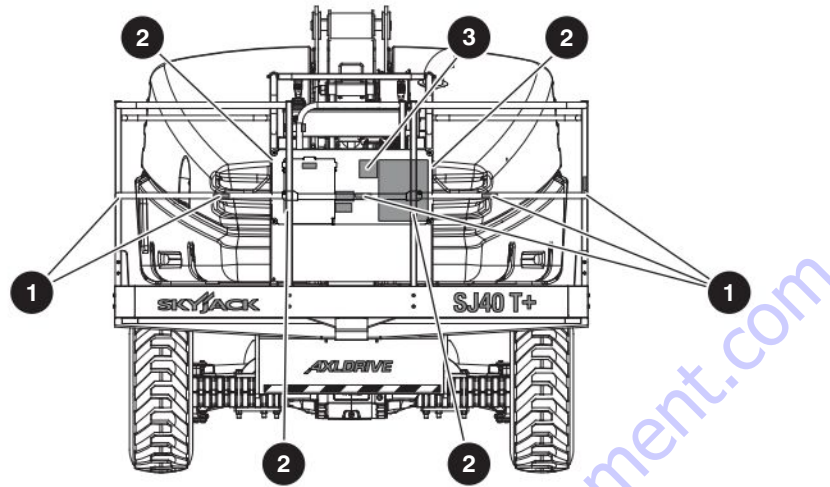

Description	Label Pictorial
<p>1 Do not step</p>	
<p>2 Fall-protection anchorages</p> <p>Attach the body-harness lanyards of each occupant to the fall-protection anchorage points.</p> <p>Rated for one (1) person for each anchorage point.</p> <p>Used for fall-restraint or fall-arrest.</p>	
<p>3 Platform capacity*</p> <p>Shows the rated work load in each configuration. The rated work load includes the weight of personnel and materials, and the maximum number of persons in each configuration. Do not exceed the total weight or maximum number of persons. Load the platform evenly.</p> <p><i>*The maximum platform capacity changes with the boom position and when the derate switch is on. The indicator lights on the base and platform control consoles show if the platform is in the high or low capacity zone.</i></p> <p>Horizontal load rating**</p> <p>Do not apply more than the specified side load. Operate the MEWP when the wind speed, which includes wind gusts, is less than the specified speed for this model.</p> <p><i>**The rating changes between different units.</i></p>	

Rear (continued)

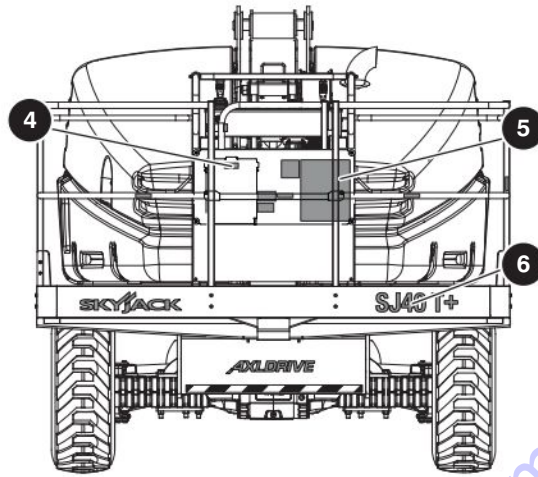

Description	Label Pictorial
-------------	-----------------

4 Manual storage box

Shows the location of the operation manual.



5 Hazard identification

Read and understand the specified hazards with this MEWP before operation. Refer to [Section 2](#).



6 Model number*

Product identifier.

**The model number can be different from the one you see.*

SJ45 T+

Rear (continued)

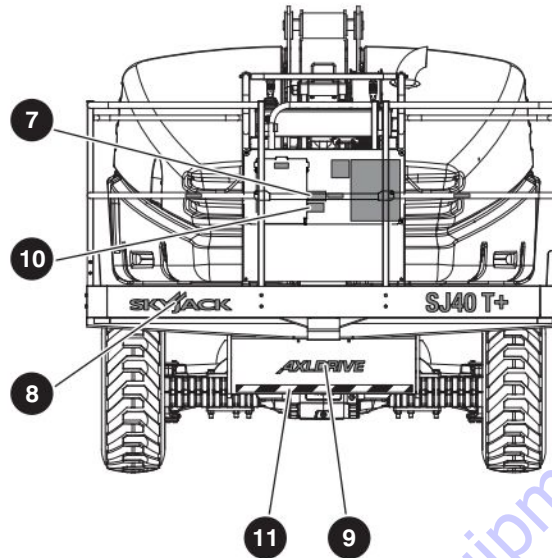

Description	Label Pictorial
<p>7 IPAF “Click It!” Wear a full body-harness with a short lanyard in boom-type platforms.</p>	
<p>8 Skyjack logo</p>	
<p>9 4x4 (optional) Product identifier - 4 wheel drive</p>	
<p>10 Warning - California proposition 65 Cancer and reproductive harm - https://www.p65warnings.ca.gov/.</p>	
<p>11 Caution tape stripe</p>	

8.7 Platform

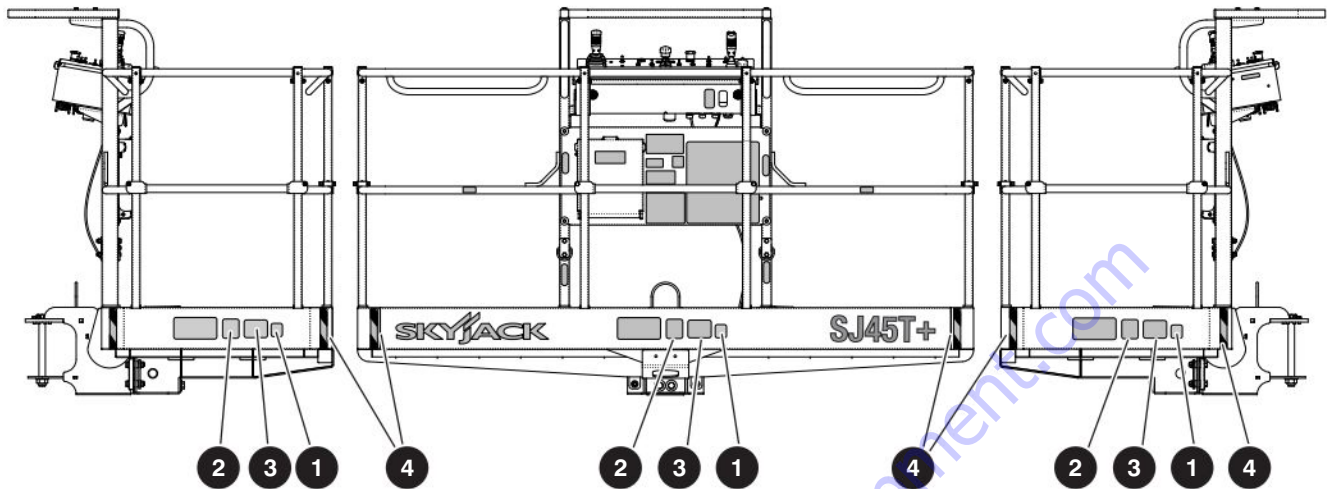

Description	Label Pictorial
<p>1 No jewelry</p> <p>Caution. Do not wear jewelry or loose clothing that could become caught or entangled.</p>	
<p>2 Operator daily inspection</p> <p>Refer to the operation manual. Do the visual inspections and function tests before you start each work shift.</p> <p>Refer to Section 4.4.</p>	
<p>3 No insulation</p> <p>This MEWP is not electrically insulated and does not provide protection from contact with or proximity to energized electrical conductors. Follow Section 2.1-1 for the minimum distance to keep between all parts of the MEWP, occupants, or tools, and the electrical conductors.</p>	
<p>4 Caution tape stripe</p>	

Platform (continued)

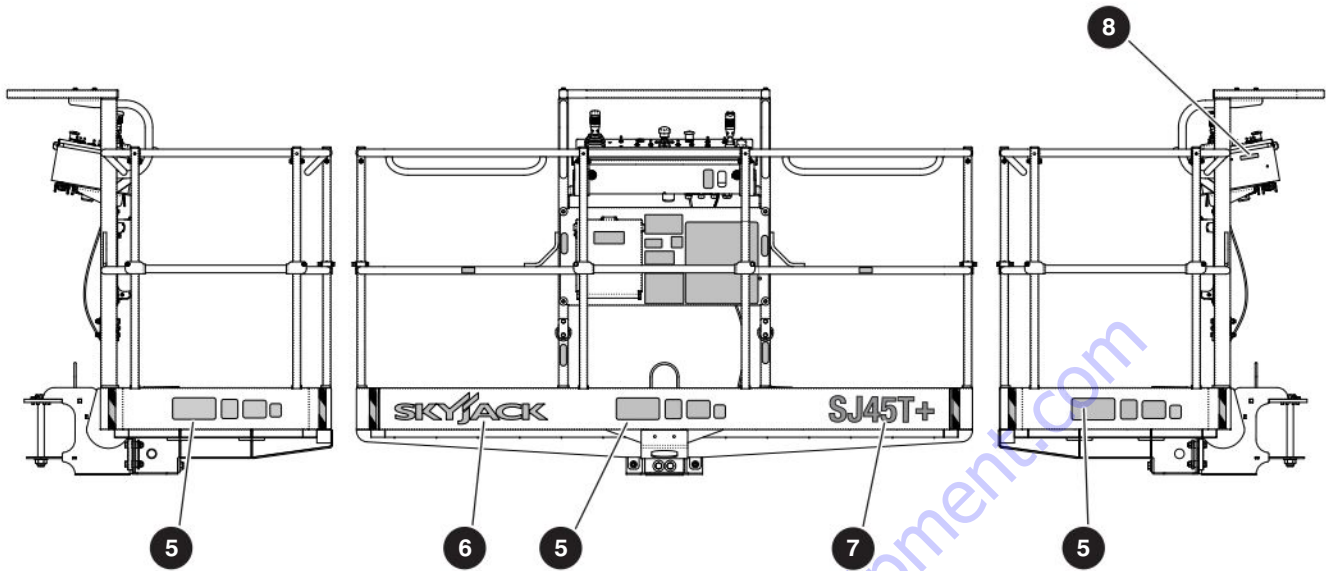

Description

Label Pictorial

5 Platform capacity*

Shows the rated work load in each configuration. The rated work load includes the weight of personnel and materials, and the maximum number of persons in each configuration. Do not exceed the total weight or maximum number of persons. Load the platform evenly.

**The maximum platform capacity changes with the boom position and when the derate switch is on. The indicator lights on the base and platform control consoles show if the platform is in the high or low capacity zone.*

Horizontal load rating**

Do not apply more than the specified side load. Operate the MEWP when the wind speed, which includes wind gusts, is less than the specified speed for this model.

***The rating changes between different units.*

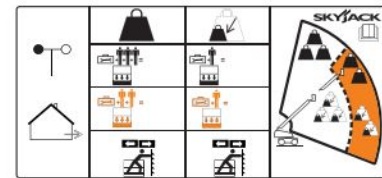
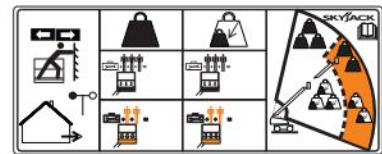

6 Skyjack logo



7 Model number

Product identifier.



8 AC power plug

Connect the AC supply here.

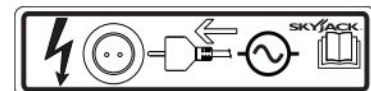

8.8 Platform railings

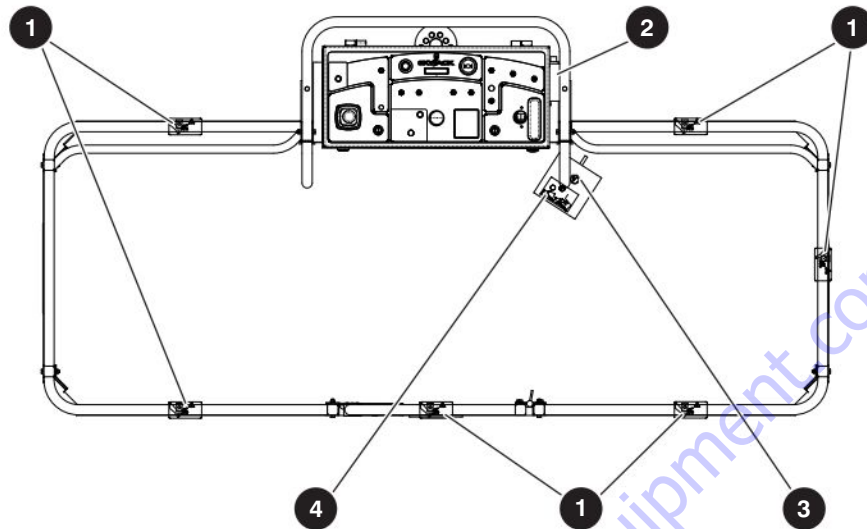

Description	Label Pictorial
<p>1 Warning - crush hazard</p>	
<p>2 AC power plug Connect the AC supply here.</p>	
<p>3 Do not alter Do not tamper with or disable the limit switches or other safety devices.</p>	
<p>4 Footswitch enable (on/off) Press and hold the footswitch to enable the platform functions.</p>	

8.9 Platform control console

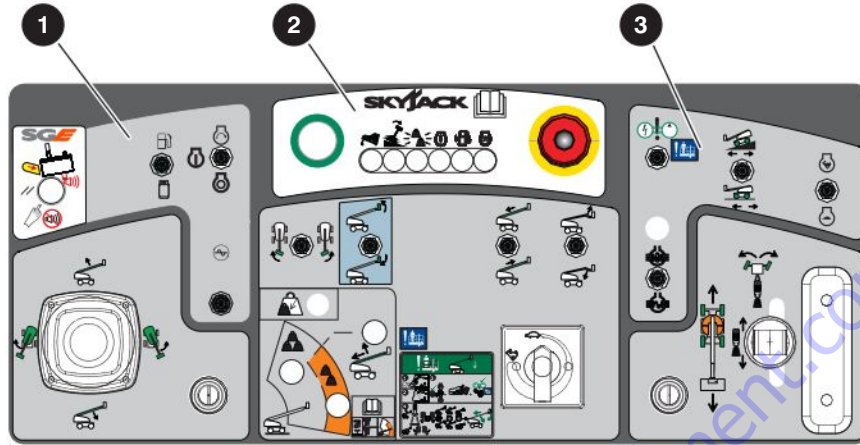

Description

Label Pictorial

1 SGE reset/start engine/generator (optional equipment)

Select the SGE reset button to reset the SGE.
 Select the dual fuel switch for gasoline or liquid propane gas.
 Push and hold the engine start/on/off switch to start the engine and then return it to the on position. Select the off position to turn the engine off.
 Select the generator on/off switch to turn the generator on or off.

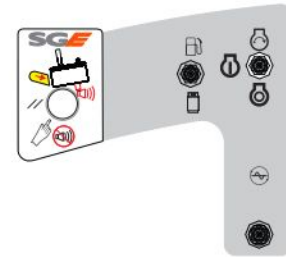

2 Horn/emergency-stop

Push the horn button to make a sound like a car horn.
 Push the emergency-stop button to stop the engine and disable the controls.



3 Emergency-power unit/engine controls

Select the emergency-power switch to enable the emergency-power unit.
 Select low torque (high speed) or high torque (low speed) with the torque switch. Select high torque when you drive on a slope.
 Select high or low engine throttle speed with the low/high throttle switch.
 Select the differential lock switch to engage or disengage the differential lock.

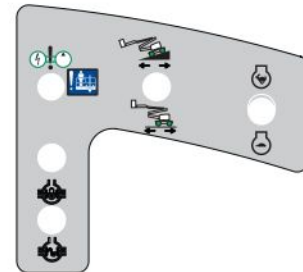

Platform control console continued

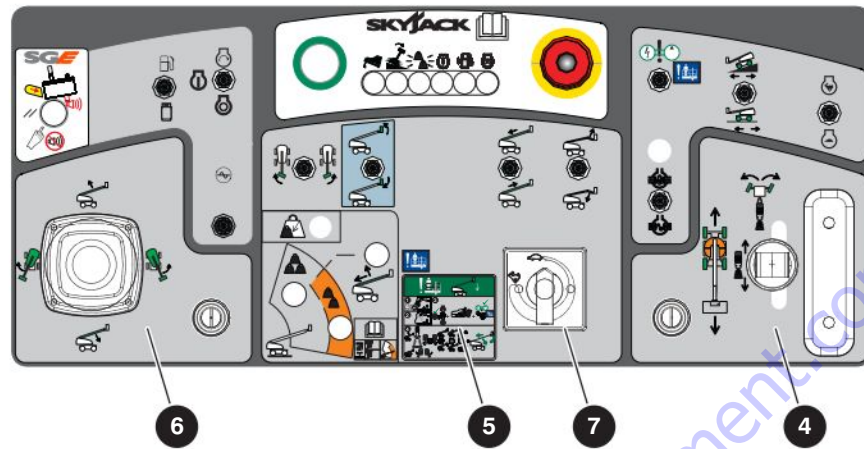

Description	Label Pictorial
<p>4 Drive/steer controller</p> <p>Press the steering rocker switch to steer left or right.</p> <p>Push and hold the drive/steer controller to drive forward or rearward.</p>	
<p>5 Emergency-lowering procedure</p> <p>Refer to the operation manual.</p> <ol style="list-style-type: none"> 1. Select the on position from the engine start/on/off switch, press and hold the footswitch, and select the emergency power. 2. Operate the necessary boom function to lower the platform. 	
<p>6 Boom/turret controller</p> <p>Push and hold the boom/turret controller to rotate the turret to the left or right.</p> <p>Push and hold the boom/turret controller to raise or lower the main boom.</p>	
<p>7 Boom Speed Adjuster Dial</p> <p>Adjust dial to vary speed of boom extension/retraction, jib raising/lowering and platform rotation movements.</p>	

Platform control console continued

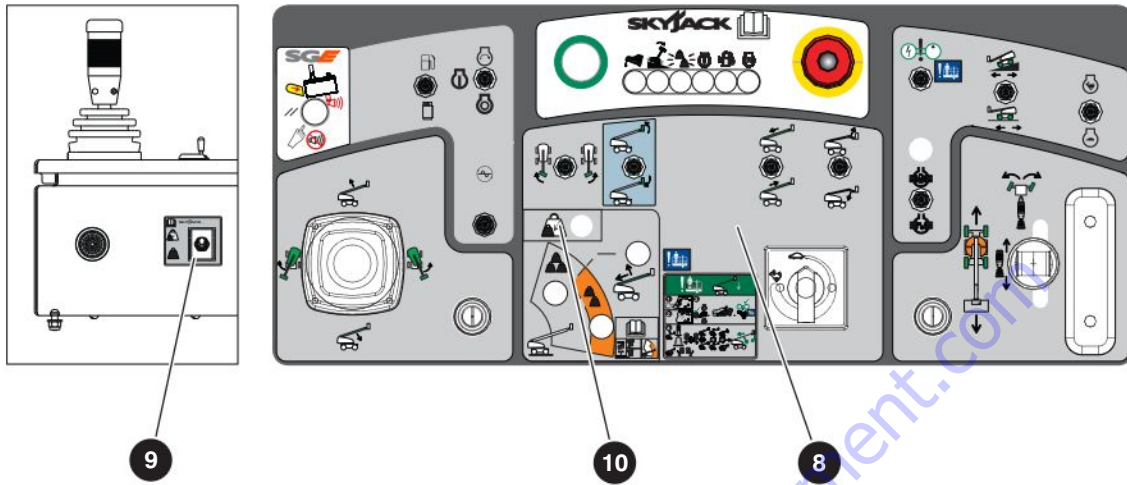

Description	Label Pictorial
-------------	-----------------

8 Boom/jib/platform controls

- Select the platform rotation switch to rotate the platform to the left or right.
- Select the platform-leveling override switch to tilt the platform up or down.
- Select the boom extend/retract switch to extend or retract the boom.
- Select the jib up/down switch to move the jib up or down.
- Select the riser raise/lower controller to raise or lower the riser.

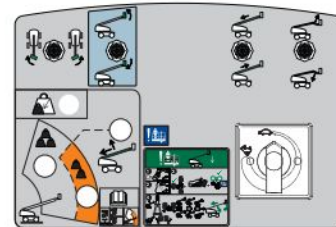

9 Capacity derate switch

- This switch controls the platform capacity. This switch derates the platform capacity to adapt to specified attachments.
- Select up for derated platform capacity and select down for full platform capacity.



10 Capacity derate light

- This light illuminates when the capacity derate switch is selected. It indicates the reduction in platform capacity



Section 9 – Unique Skyjack Features

Your Skyjack MEWP may be equipped with the following unique features:

ACCESSORYZERS™

Having equipment with features and functionality that allow you and your customers to do more is a vital part of the utilization equation. Skyjack offers a range of accessory products to further expand a given product's adaptability and your power to offer a truly flexible rental choice.

AXLDRIVE™

Skyjack's mechanical "axle based" drive system gives positive traction and excellent rough ground "terrain-ability". This is achieved using an automatic or manual (model dependent) locking differential on the rear axle and limited slip differential on the front axle. This means MEWPs can climb grades of up to 30% in the case of Rough Terrain Scissor Lifts, and 50% in the case of Boom Lifts. This industry-leading terrain capability means one can use the Skyjack Rough Terrain Scissor Lifts and Boom Lifts in the most challenging of conditions.

EASYDRIVE™

A unique boom feature only utilized by Skyjack - the Boom Lift drive function operates in accordance with the general orientation of the turret's counterweight over the chassis (i.e., controller handle forward = counterweight facing forward). This provides intuitive operation by allowing the unit to move in the general direction of the controller handle's movement.

SKYCODED™

At the heart of every Skyjack machine is our proven and simplistic control system. Skyjack's color-coded and numbered wiring system make our machines the easiest to troubleshoot and repair, translating into less maintenance and lower costs for our customers. The control system on Skyjack's Full-Size Rough Terrain Scissor Lifts pairs the simplistic reliability of the color-coded and numbered wires with a single control module that manages machine functions, while a visual display module at the base control box provides an easy to navigate interface – outputting plain text and easily understood codes.

SKYRISER™

A unique feature found on Skyjack's articulating boom lift. It ensures that the riser and main pivot point connecting the boom to the riser travel in a straight vertical line. Movement in a true vertical manner, without drifting forward or back, reduces the amount of repositioning the operator needs to do in order to stay close to a building façade.

SPEEDYREACH™

Skyjack's Articulated Boom Lifts feature a boom geometry that allows the operator to lower the main boom to ground level to restock on material or supplies then return to full height at the original working position - without lowering the riser section. This functionality adds to the versatility and productivity of Skyjack's Articulating Boom Lifts, especially as it can be quickly executed and there is no need for machine repositioning or having to remember the sequence of operations to get back to the original working position.



WARNING

Cancer and Reproductive Harm-
<https://www.p65warnings.ca.gov/>.

To order go to DiscountEquipment.com

TO PURCHASE THIS PRODUCT PLEASE CONTACT US



**Equipment Financing and
Extended Warranties Available**



**Discount-Equipment.com is your online resource for
commercial and industrial quality parts and equipment sales.**

561-964-4949

visit us on line @ www.discount-equipment.com

Select an option below to find your Equipment

Search by Manufacturer

Search by Product Type

Request a Quote

We sell worldwide for the brands: Genie, Terex, JLG, MultiQuip, Mikasa, Essick, Whiteman, Mayco, Toro Stone, Diamond Products, Generac Magnum, Airman, Haulotte, Barreto, Power Blanket, Nifty Lift, Atlas Copco, Chicago Pneumatic, Allmand, Miller Curber, Skyjack, Lull, Skytrak, Tsurumi, Husquvarna Target, Stow, Wacker, Sakai, Mi-T-M, Sullair, Basic, Dynapac, MBW, Weber, Bartell, Bennar Newman, Haulotte, Ditch Runner, Menegotti, Morrison, Contec, Buddy, Crown, Edco, Wyco, Bomag, Laymor, EZ Trench, Bil-Jax, F.S. Curtis, Gehl Pavers, Heli, Honda, ICS/PowerGrit, IHI, Partner, Imer, Clipper, MMD, Koshin, Rice, CH&E, General Equipment, Amida, Coleman, NAC, Gradall, Square Shooter, Kent, Stanley, Tamco, Toku, Hatz, Kohler, Robin, Wisconsin, Northrock, Oztec, Toker TK, Rol-Air, APT, Wylie, Ingersoll Rand / Doosan, Innovatech, Con X, Ammann, Mecalac, Makinex, Smith Surface Prep, Small Line, Wanco, Yanmar



www.Discount-Equipment.com

To order go to Discount-Equipment.com

