

APS31 / 41

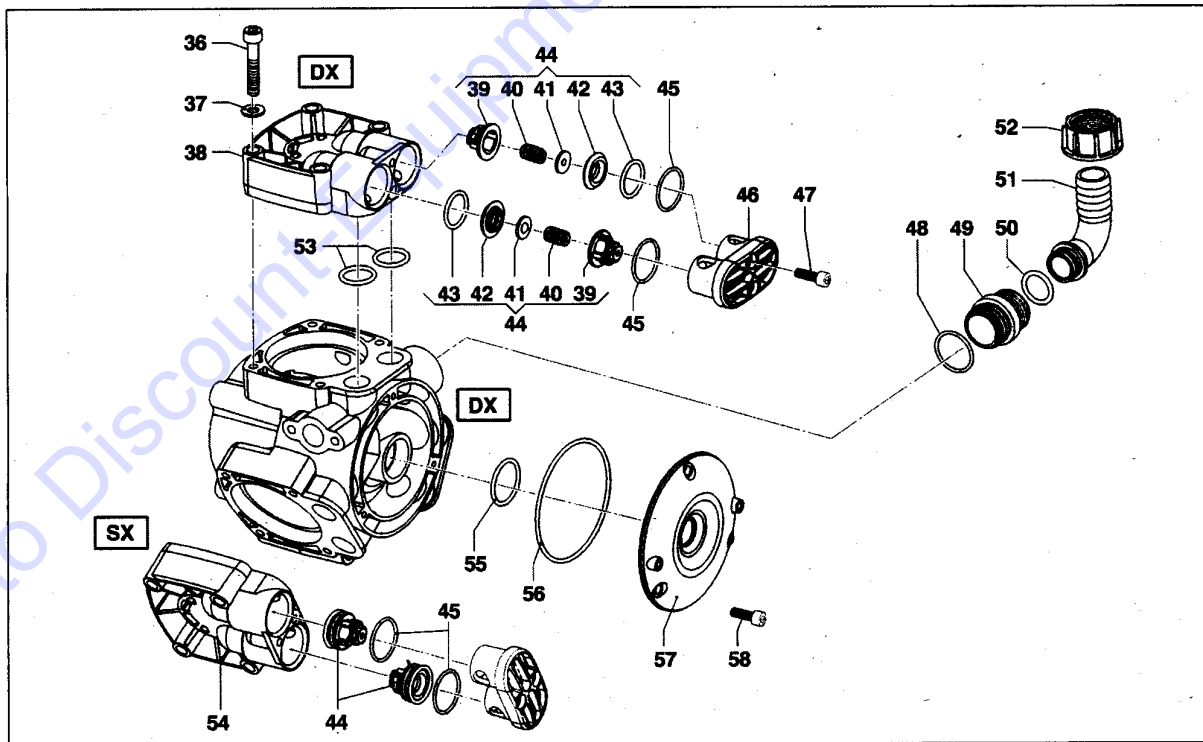

Gearbox Breakdown

Part #5005/216

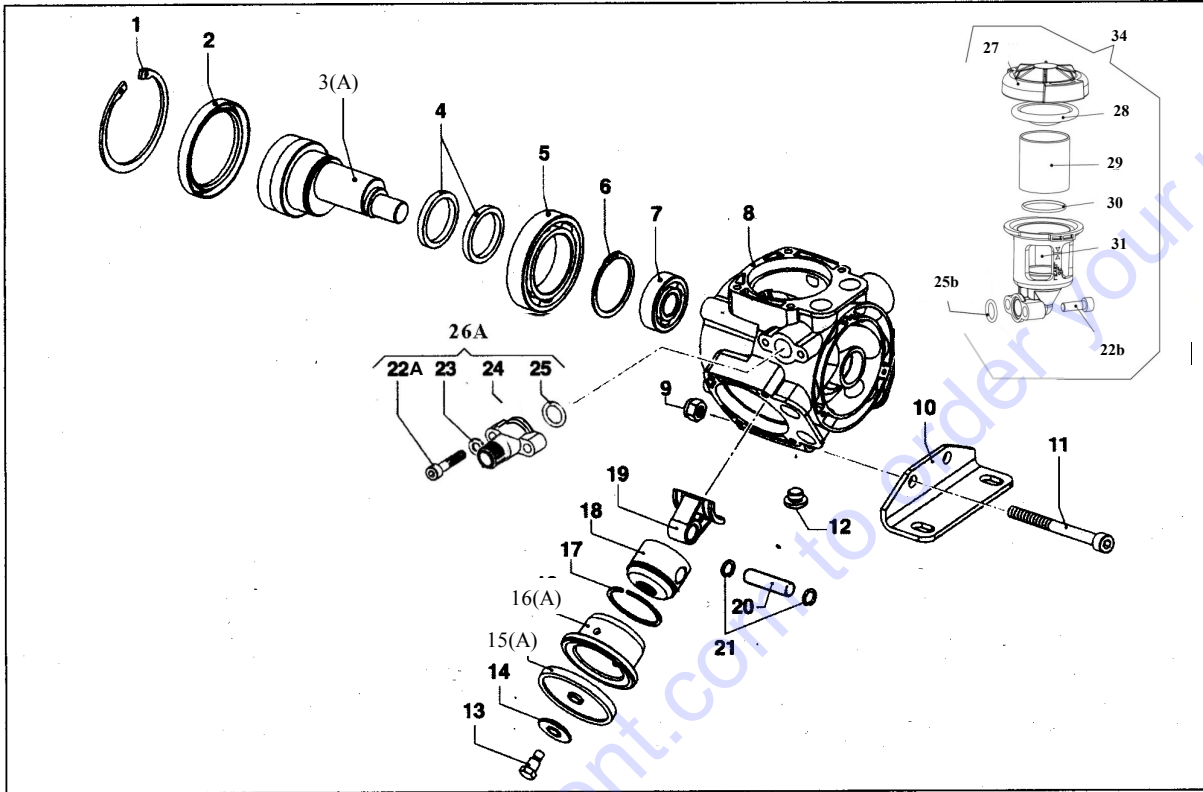
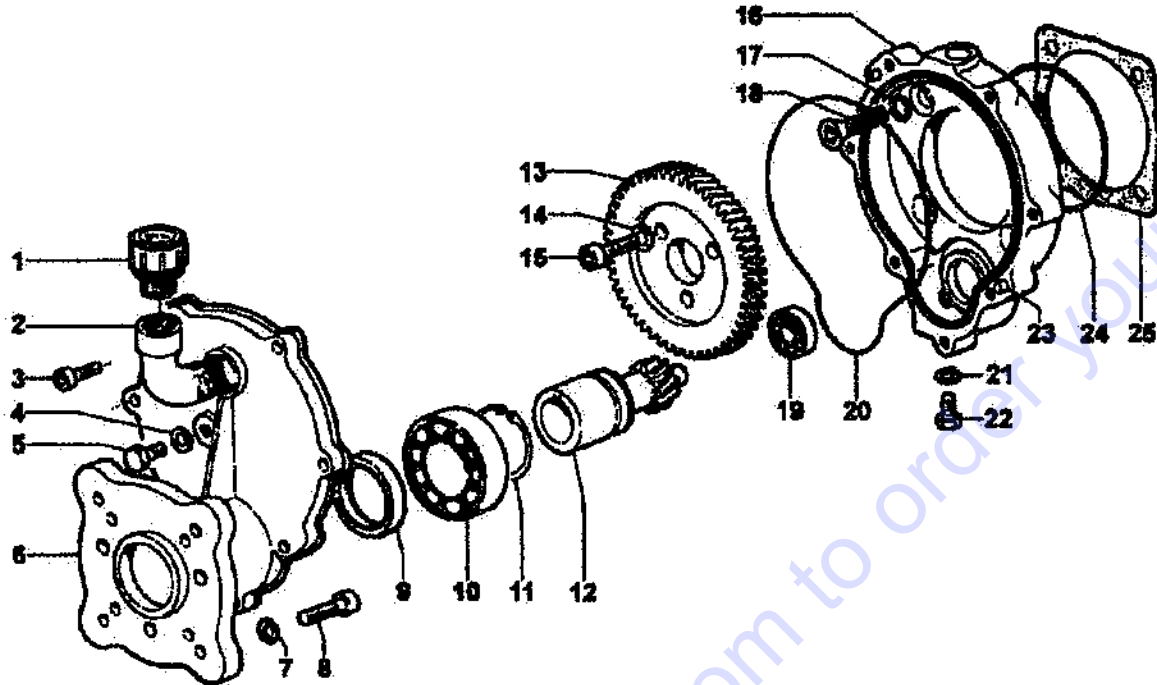

Reference	Part Number	Description	Quantity
1	3200/82	oil vent cap	1
2	1211/23	elbow	1
3	3609/41	screw	7
4	2811/51	washer	1
5	3607/214	level indicator plug	1
6	3002/559	body	1
7	2811/4	washer	4
8	3607/119	screw	4
9	19/109	oil seal	1
10	438/68	bearing	1
11	3019/4	retaining clip	1
12	2402/152	shaft	1
13	409/14	gear	1
14	2811/98	washer	3
15	3609/22	screw	3
16	3001/151	body	1
17	1210/93	o-ring	4
18	3621/6	screw	4
19	438/54	bearing	1
20	1210/89	o-ring	1
21	2811/51	washer	1
22	3607/214	oil plug	1
23	2818/5	stabilizing pin	2
24	1210/50	o-ring	1
25	1201/21	gasket	1

PARTS BREAKDOWN FOR MODEL DP(H)-3B w/COMET
RICE HYDRO INC.

PUMP PARTS:

REF#	PART NUMBER..	DESCRIPTION..	QTY REQ'D
1	D3-3020-0002	RETAINING CLIP	1
2	D3-0019-0085	SEALING RING	1
3	D3-0001-0444	SHAFT	1
4	D3-0010-0026	CONNECTING ROD RING	2
5	D3-0438-0001	BEARING	1
6	D3-3019-0001	RETAINING CLIP	1
7	D3-0438-0066	BEARING	1
8	D3-0403-0147	CRANKCASE	1
12	D3-3200-0080	OIL PLUG	1
13	D3-3605-0027	BOLT	3
14	D3-0602-0008	DISC	3
15	D3-1800-0020	DIAPHRAGM (in KIT's RH1 & RH2)	3
16	D3-0400-0080	PISTON SLEEVE	3
17	D3-0020-0010	COMPRESSION RING	3
18	D3-2409-0097	PISTON	3
19	D3-0205-0069	CONNECTING ROD (SET OF 3)	1
20	D3-3011-0024	PIN	3
21	D3-3020-0029	RETAINING CLIP	6
22B	D3-3609-0006	ONLY AVAILABLE IN KIT RH5	2
25B	D3-1210-0390	ONLY AVAILABLE IN KIT RH5	1
26A	D3-2803-0662	OUTLET ADAPTER KIT - after S/N 40908	1
26A	D3-2803-0474	OUTLET ADAPTER KIT - before S/N 40908	1
27	D3-0402-0522	ONLY AVAILABLE IN KIT RH5	1
28	D3-1800-0001	ONLY AVAILABLE IN KIT RH5	1
29	D3-1809-0001	ONLY AVAILABLE IN KIT RH5	1
30	D3-1210-0030	ONLY AVAILABLE IN KIT RH5	1
31	D3-0421-0035	ONLY AVAILABLE IN KIT RH5	1
36	D3-3609-0014	SCREW	12
37	D3-2811-0004	WASHER	12
38	D3-3218-0537	HEAD (DX) located top and inlet side Ref #38A spacer included with 3218-0537	2
38A	D3-0601-0436	SPACER	2
44	D3-1220-0052	VALVE ASSY W/ORING (in KIT's RH1, RH3)	6
45	D3-1210-0015	O-RING FOR #46 PLUG (in KIT's RH1, RH3)	6
46	D3-3202-0259	PLUG	3
47	D3-3609-0032	SCREW	6
48	D3-1210-0145	O-RING	1
49	D3-2000-0100	NIPPLE	1
50	D3-1210-0048	O-RING	1
51	D3-2801-0075	HOSE BARB	1
52	D3-1200-0049	WING NUT	1
53	D3-1210-0048	O-RING #38/54 (in KIT's RH1, RH2, RH3)	6
54	D3-3218-0538	HEAD (SX) located pressure side Ref #54A spacer included with 3218-0538	1
54A	D3-0601-0436	SPACER	2
55	D3-1210-0101	O-RING	1
56	D3-1210-0225	O-RING	1
57	D3-1009-0181	FLANGE	1
58	D3-3609-0032	SCREW	3

PUMP OUTLET CONNECTIONS TO PIPING: (REF 26A CONNECTED TO PUMP)		
EL-BRASS-1/2	1/2" BRASS ELBOW	1
HOSE-1/2X19	HOSE	1
D3-2803-0662	OUTLET ADAPTER ASSEMBLY	1

REF#	PART NUMBER..	DESCRIPTION..	QTY REQ'D
GEAR REDUCTION:			
1	D3-3200-0082	OIL VENT CAP	1
2	D3-1211-0023	ELBOW	1
3	D3-3609-0041	SCREW	7
4	D3-2811-0051	WASHER	1
5	D3-3607-0214	LEVEL INDICATOR PLUG	1
6	D3-3002-0559	BODY	1
7	D3-2811-0004	WASHER	4
8	D3-3607-0119	SCREW	4
9	D3-0019-0109	OIL SEAL	1
10	D3-0438-0068	BEARING	1
11	D3-3019-0004	RETAINING CLIP	1
12	D3-2402-0152	SHAFT	1
13	D3-0409-0014	GEAR	1
14	D3-2811-0098	WASHER	3
15	D3-3609-0022	SCREW	3
16	D3-3001-0151	BODY	1
17	D3-1210-0093	O-RING	4
18	D3-3621-0006	SCREW	4
19	D3-0438-0054	BEARING	1
20	D3-1210-0089	O-RING	1
21	D3-2811-0051	WASHER	1
22	D3-3607-0214	OIL PLUG	1
23	D3-2818-0005	STABILIZING PIN	2
25	D3-1201-0021	GASKET	1

MISCELLANEOUS PARTS:

NA	GAUGE-600	0-600 PSI LIQUID GAUGE	1
NA	BALLVALVE-1/2	1/2" F X F BALLVALVE	1
NA	CHECKVALVE-1/2F	1/2" F X F 1200PSI INLINE CHECKVALVE	1
NA	CHECKVALVE-1/2M	1/2" M X M INLINE CHECKVALVE	1
NA	SPRAY-6815-700-1/2	1/2" PRESSURE RELIEF VALVE	1
NA	BRIGG-130G32-0022-F1	206 CC FLANGE MOUNT BRIGGS ENGINE	1
NA	HONDA-GX200UT2-QX2	196 CC FLANGE MOUNT HONDA ENGINE	1
NA	KING-LARGE	SHIPPING BOX FOR DP(H)-3B	1
NA	INLET-HOSE-ASSEMBLY	1" X 9' FOOT CLEAR HOSE W/STRAINER	1
NA	FILTER-SUMP-INLET	1&1/4" 100 MESH INLET STRAINER	1
NA	PUMP-DIA-11/550PSI	REPLACE PUMP W/GEAR REDUCTION	1
NA	PUMP-DIA-11/550W/OGR	REPLACE PUMP W/O GEAR REDUCTION	1
MUST ORDER D3-2803-0662 WHEN ORDERING REPLACEMENT PUMP			
NA	D3-5005/216	GEAR REDUCTION	1
NA	DIAPHRAGM-SUCTION	1&1/2" BLACK INLET SUCTION DIAPHRAGM	1
NA	DIAPHRAGM-CLAMP	1&1/2" INLET SUCTION CLAMP	1
NA	LINESTRAINER-1"	1" INLINE STRAINER	1
NA	LABEL-KIT-DP	INSTRUCTION AND CAUTION STICKERS	1
NA	TANK-CAP-ASSY	LID, FLANGE, SCREWS AND CHAIN	1

OUTLET HOSE:

HOSE-1/2X8-RH	8' FOOT OUTLET HOSE - STANDARD	1
COUPLERBODY-1/2	FEMALE PUMP OUTLET - HOSE	1
COUPLERPLUG-1/2	MALE PUMP OUTLET - PIPING	1
FITTING-1/2MPIPE	FITTING FOR HOSE - RIGID	1
FITTING-1/2-MPX	FITTING FOR HOSE - SWIVEL	1
HOSE-1/2-2500XFT	SPECIFY LENGTH OF HOSE	

REF#	PART NUMBER..	DESCRIPTION..	QTY REQ'D
------	---------------	---------------	--------------

KITS:

D3-KIT-RH1	DIAPHRAGM REBUILD KIT	
	REF. #15 DIAPHRAGM	QTY 3
	REF. #44 VALVE ASSY W/ORING	QTY 6
	REF. #45 ORING FOR #46 PLUG	QTY 6
	REF. #53 O-RING #38/54 HEAD	QTY 6
	DIAPHRAGM-SUCTION	QTY 1
D3-KIT-RH2	DIAPHRAGM REPAIR KIT	
	REF. #15 DIAPHRAGM	QTY 3
	REF. #53 O-RING #38/54 HEAD	QTY 6
D3-KIT-RH3	VALVE ASSEMBLY & O-RING KIT	
	REF. #44 VALVE ASSY W/ORING	QTY 6
	REF. #45 O-RING FOR #46 PLUG	QTY 6
	REF. #53 O-RING #38/54 HEAD	QTY 6
D3-KIT-RH5	NEW STYLE ALUMINUM SIGHT GLASS KIT	
	REF. #22B SCREW 30MM	
	REF. #25B O-RING	
	REF. #27 CAP	
	REF. #28 DIAPHRAGM	
	REF. #29 OIL CUP	
	REF. #30 O-RING	
	REF. #31 OIL CUP	

Go to Discount-Equipment.com to order your parts

PARTS FINDER

**Search Website
by Part Number**



**Search Manual
Library For Parts
Manual & Lookup Part
Numbers – Purchase
or Request Quote**

Search Manuals

Enter your information to search for a manual or to purchase a manual or parts.

* Brand:

* Model:

* Serial:

* Part Number:

SEARCH

**Can't Find Part or
Manual? Request Help
by Manufacturer,
Model & Description**

Parts Order Form

Please fill in the following information to request help finding a part or manual.

Manufacturer:

Model:

Description:

Quantity:

Part Number:

Part Name:

Part Description:

Part Category:

Part Location:

Part Status:

Part Condition:

Part Material:

Part Color:

Part Weight:

Part Dimensions:

Part Price:

Part Availability:

Part Lead Time:

Part Notes:

Submit

Discount-Equipment.com is your online resource for quality parts & equipment.

Florida: **561-964-4949** Outside Florida TOLL FREE: **877-690-3101**

Need parts?

Click on this link: <http://www.discount-equipment.com/category/5443-parts/> and choose one of the options to help get the right parts and equipment you are looking for. Please have the machine model and serial number available in order to help us get you the correct parts. If you don't find the part on the website or on one of the online manuals, please fill out the request form and one of our experienced staff members will get back to you with a quote for the right part that your machine needs.

We sell worldwide for the brands: Genie, Terex, JLG, MultiQuip, Mikasa, Essick, Whiteman, Mayco, Toro Stone, Diamond Products, Generac Magnum, Airman, Haulotte, Barreto, Power Blanket, Nifty Lift, Atlas Copco, Chicago Pneumatic, Allmand, Miller Curber, Skyjack, Lull, Skytrak, Tsurumi, Husquvarna Target, Stow, Wacker, Sakai, Mi-T-M, Sullair, Basic, Dynapac, MBW, Weber, Bartell, Bennar Newman, Haulotte, Ditch Runner, Menegotti, Morrison, Contec, Buddy, Crown, Edco, Wyco, Bomag, Laymor, EZ Trench, Bil-Jax, F.S. Curtis, Gehl Pavers, Heli, Honda, ICS/PowerGrit, IHI, Partner, Imer, Clipper, MMD, Koshin, Rice, CH&E, General Equipment, Amida, Coleman, NAC, Gradall, Square Shooter, Kent, Stanley, Tamco, Toku, Hatz, Kohler, Robin, Wisconsin, Northrock, Oztec, Toker TK, Rol-Air, APT, Wylie, Ingersoll Rand / Doosan, Innovatech, Con X, Ammann, Mecalac, Makinex, Smith Surface Prep, Small Line, Wanco, Yanmar